



**UNITED
TECHNOLOGIES
CARRIER**

Commercial Division
Carrier Corporation

BULLETIN: CA-SB-19-D-66-31
DATE: 7/7/66
PAGE: 1 OF 3

SERVICE BULLETIN

SUBJECT: FLOAT CHAMBER EQUALIZING VALVE AND
CHAMBER VENT; 19D11, 21, 31

SUPERSEDE
BULLETIN:
DATE:
PAGE: OF:

Installation, repair and service and equipment referenced in this Service Bulletin should be undertaken only by qualified persons. Carrier Corporation (1) makes no representations or warranties, expressed or implied, concerning the accuracy, completeness or right to use the information contained herein, and (2) disclaims all liability for injuries, damages, infringements and other losses which may arise on account of, or which may result from, the use or application of any information, method or apparatus disclosed herein.

PURPOSE

To transmit information on design improvements to the float chamber equalizing valve and the 19D31 chamber vent, and to forward instructions for adapting existing machines to these design improvements.

MACHINES AFFECTED

All 19D11, 19D21, and 19D31 machines.

PROCEDURES

- A. Equalizing Valve. Machines shipped after March 1, 1965 (approximate unishell Serial No. 25780 and higher) have a newly designed equalizing valve in the float chambers (Fig. 1.) When exposed to refrigerant, the earlier neoprene design could possibly curl, keeping the valve partially open during machine operation.

Use check valve assembly 19U21-853 on 19D21 and 19D31 machines as a field replacement for the neoprene equalizing valve (Fig. 2) whenever the machine is opened for any reason. Drilling and tapping is not required. Use the existing 1/4-20 and 1/2-13 holes to bolt on the check valve and plate assembly.

On 19D11 machines only, the equalizing valve is not required and can be removed by tapping and plugging the three 1/2" drilled-through holes. (Use pipe tap size 3/8-18.) 19D11 unishells manufactured after approximately March 1, 1965, do not include an equalizing valve.

- B. 19D31 Chamber Vent. On 19D31 machines manufactured prior to October 1965, an incorrect refrigerant level can result if a gas pocket forms in the upper portion of the lower chamber. This pocket can form if the liquid level rises above the outlet of the liquid line from the upper float chamber, and may prevent a further increase in the refrigerant level.

19D31 unishells built since October 1965 have a 1/8" diameter vent hole, drilled as shown in Fig. 3, to eliminate this gas pocket.

Whenever the lower float chamber cover is removed from a 19D31 machine, drill a 1/8" vent hole in the valve plate, as shown in Fig. 3.



**UNITED
TECHNOLOGIES
CARRIER**

Commercial Division
Carrier Corporation

BULLETIN: CA-SB-19-D-66-31
DATE: 7/7/66
PAGE: 2 OF: 3

SERVICE BULLETIN

SUPERSEDE
BULLETIN:
DATE:
PAGE: OF:

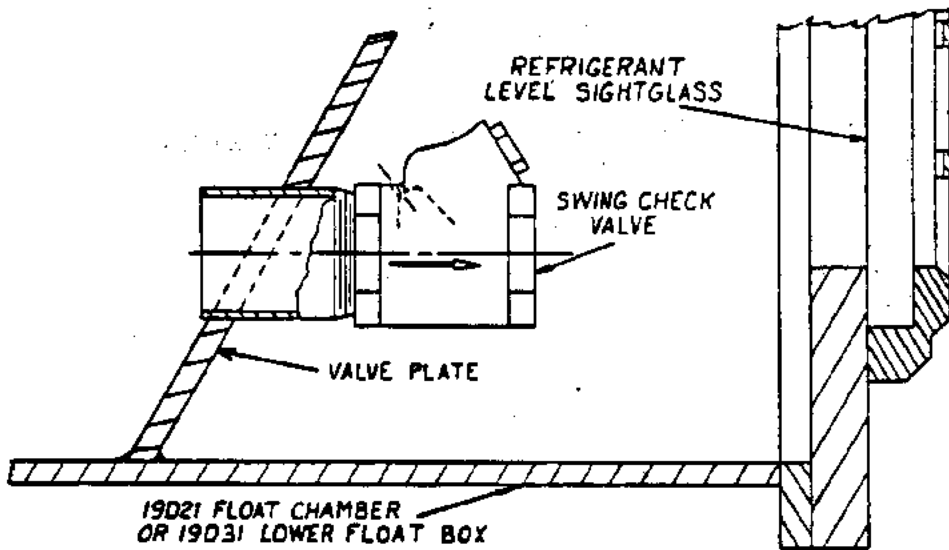

Fig. 1
Equalizing
Valve
Arrangement



**UNITED
TECHNOLOGIES
CARRIER**

Commercial Division
Carrier Corporation

BULLETIN: CA-SB-19-D-66-31
DATE: 7/7/66
PAGE: 3 OF: 3

SERVICE BULLETIN

SUPERSEDE
BULLETIN:
DATE:
PAGE: OF:

