



**UNITED
TECHNOLOGIES
CARRIER**

Commercial Division
Carrier Corporation

BULLETIN: CA-SB-19-C-60-7
DATE: 4/20/60
PAGE: 1 OF: 16

SERVICE BULLETIN

SUBJECT:

COMPRESSOR IMPELLER SPACING

SUPERSEDE

BULLETIN:

DATE:

PAGE: OF:

Installation, repair and service and equipment referenced in this Service Bulletin should be undertaken only by qualified persons. Carrier Corporation (1) makes no representations or warranties, expressed or implied, concerning the accuracy, completeness or right to use the information contained herein, and (2) disclaims all liability for injuries, damages, infringements and other losses which may arise on account of, or which may result from, the use or application of any information, method or apparatus disclosed herein.

PURPOSE

This bulletin is intended to give a step by step procedure to follow when disassembling and reassembling the 19C compressor. This bulletin should be read thoroughly before attempting to rebuild a compressor. All tools and materials should be procured prior to starting.

MACHINES AFFECTED: 19C Hermetic Centrifugal

DESCRIPTION

Tools and materials required to perform the various steps included in this bulletin are as follows:

1. Steel straight edge- 6ft. long
2. Wheel puller (Figure 7)
3. On 19C3, 4 and 5 machines shipped after mid February 1960 and 19C6, 7 and 8 with new style bearing pedestal, shaft can be floated by removing the thrust bearing assembly and inverting the lower journal bearing.
4. Dial indicator
5. White lead compound.
6. Asbestos gloves
7. "Tempilstick" 200F - 250F range (purchased from most welding supply houses.)
8. Acetylene burning outfit with rosebud tip.
9. Extra brass shim (between 2nd stage impeller and thrust nut) Carrier part number 19C47-1831 for all 19C3 4 and 5 and Carrier part number 19C67-1831 for all 19C6, 7 and 8. This shim is .126" thick and has .003" laminations.
10. Depth micrometer or vernier type depth gauge
11. Long thickness gauge set.
12. Necessary rigging equipment



**UNITED
TECHNOLOGIES
CARRIER**

Commercial Division
Carrier Corporation

BULLETIN: CA-SB-19-C-60-7
DATE: 4/20/60
PAGE: 2 OF: 16

SERVICE BULLETIN

SUPERSEDE
BULLETIN:
DATE:
PAGE: OF:

COMPRESSOR DISASSEMBLY

The procedure to disassemble the compressor is as follows:

1. Remove inlet venturi.
2. Remove shaft cap, locknut and lock washer.
3. Remove compressor intake wall.
4. Remove 1st stage impeller. Pull impeller with wheel puller while applying heat evenly to hub. Impeller hub interference to shaft is approximately .0015".

CAUTION: Use "Tempilstick" to check temperature of impeller. Do Not heat impeller above 250 °F.

5. Remove key from shaft keyway. Mark key with punch mark to be certain of its position and location when re-assembling the compressor.

NOTE: All R-113 machines have one key per impeller all R-11 machines (with a few exceptions on early machines) have two keys for impeller spaced 180° apart.

6. Remove impeller spacer, 1st stage labyrinth and shaft labyrinth.
7. Remove compressor diaphragm.
8. Remove discharge volute.
9. Remove 2nd stage impeller using procedure in step 4 above.
10. Remove key from shaft as in step 5 above.
11. Remove 2nd stage labyrinth.
12. Remove shim.



**UNITED
TECHNOLOGIES
CARRIER**

Commercial Division
Carrier Corporation

BULLETIN: CA-SB-19-C-60-7

DATE: 4/20/60₁₆

PAGE: OF: 1

SERVICE BULLETIN

SUPERSEDE

BULLETIN:

DATE:

PAGE: OF:

COMPRESSOR REASSEMBLY

STEP NO. 1 CHECKING TRUENESS & CONCENTRICITY OF SHAFT

- a. Insure that the thrust and journal bearings are installed and properly fitted.
- b. Check shaft concentricity to labyrinth land. Install dial indicator linkage on shaft and rotate dial slowly around labyrinth land. (See photo 1). This concentricity should be within .002" TIR (Total Indicated Reading).
- c. Check shaft end runout with a dial indicator as shown in photo 2. Runout should not exceed .001" TIR.
- d. Check "squareness" of shaft to motor shell flange by mounting dial indicator linkage on shaft and rotating dial against flange as shown in photo 3. "Squareness" should be within .007" TIR.

STEP NO. 2 - SPACING THE 2nd STAGE IMPELLER

- a. Lay the second stage impeller face down and fit the second stage labyrinth to the labyrinth ring. The clearance between the labyrinth and labyrinth ring should be .012" - .017".
- b. Install the second stage labyrinth to the motor shell.
- c. With the dial indicator linkage on the shaft and the dial on the labyrinth blades, (use wide dial button) check concentricity of labyrinth to shaft by rotating the shaft slowly. Concentricity should be within .004" TIR.
- d. Force the shaft in the thrust position.
- e. Place the steel straight edge against the motor shell flange as shown in Figure 1. Measure and record dimensions "A" and "B".

NOTE: All measurements should be made to the nearest .001" with a depth micrometer.

- f. Place the discharge volute face down on the floor and place the 2nd stage impeller inside the volute as shown in Figure 2. Center the impeller by repositioning the straight edge and checking dimension "M" in several places. Dimension "M" should be the same all around within .003".
- g. Measure and record dimension "C".
- h. The thickness of the shim required between the 2nd stage impeller and the thrust nut can be determined if you follow this example. Assume the following dimensions as an example:



SERVICE BULLETIN

SUPERSEDE
BULLETIN:
DATE:
PAGE: OF:

"A" Straightedge to flange = 1.249"
"B" Straightedge to thrust nut = .449"
"C" Straightedge to impeller hub = .977
Desired clearance in front of impeller = .050"
(Clearance should be 0.045" to 0.050")

1. "A" minus "B" (1.249" - .449) = 0.800"
2. "C" minus desired clearance (.977" - .050") = 0.927"
3. Result in 2 above minus result in 1 above (0.927" - 0.800") = 0.127"
4. Shim thickness = 0.127"

- i. Install a shim of proper thickness as determined by above method.
- j. Before installing the second stage impeller, examine the keys and keyways. Be sure keyways, keys and impeller hub bore are free of burrs.
- k. The keys should fit in the keyways so they are snug. Be sure keys are properly located per punch marks.

CAUTION: Because of a change in impeller keyway depth, it may be necessary to fabricate new keys of greater thickness when replacing impellers on older machines.

- l. If installing a new impeller, check the overall shaft diameter with the keys in place against the overall diameter of the impeller hub bore taken at the bottom of the impeller keyway. The latter dimension should be 1/32" greater to prevent interference between the top of the key and the bottom of the hub keyway.
- m. Apply a light coat of white lead to the impeller bore.

- n. Screw the center stud (36") of the wheel pulling assembly into the shaft end. Screw the two side studs (24") on to the impeller hub and install the center bar over these studs.

- o. Heat the impeller hub evenly with an acetylene torch using the rosebud tip.

CAUTION: Do not heat impeller above 250°F. Check continually with "Tempilstick".

- p. Using asbestos gloves, install impeller quickly on to shaft while heating the hub continually to prevent the impeller from binding on the shaft.
- q. The torch should be applied to the impeller hub for a few minutes during the cool down period to permit the back of the impeller to cool first and seize the shaft. Cooling will then be from the back of the impeller to the front of the impeller preventing the impeller from "creeping" away from the shim. Keep the wheel puller in the pushing position (figure 3) until the impeller has cooled sufficiently.
- r. Insure that the impeller did not "creep" during the cooling period by attempting to insert a feeler gauge between shim and impeller hub through the main bearing inspection cover.



**UNITED
TECHNOLOGIES
CARRIER**

Commercial Division
Carrier Corporation

BULLETIN: CA-SB-19-C-60-7
DATE: 4/20/60
PAGE: 5 OF: 16

SERVICE BULLETIN

SUPERSEDE
BULLETIN:
DATE:
PAGE: OF:

- s. Before installing discharge volute, rotate shaft and listen for any rubbing. Recheck shaft end runout to be sure heating did not distort shaft.
- t. Install discharge volute.
- u. With a long thickness gauge check clearance of each blade to inlet ring. Should be 0.035" to 0.050". (See Figure 4 for location of this dimension.)

STEP NO. 3 - CHECKING SECOND STAGE IMPELLER CLEARANCE

Before proceeding further with the compressor reassembly, the shaft should be floated to check front and back second stage impeller clearance.

- a. On machines with original style motor end-bell, install set-up bar across end bell opening. On machines with new style end bell, "K" dimension can be taken directly from end of shaft to end cover flange with depth micrometer. (see photo 4)
- b. With the thrust bearing fitted and in place, force the shaft toward the compressor end until the thrust ring is against the thrust bearing.
- c. Measure and record the dimension from the end of the shaft and the set-up bar. Use depth micrometer for this measurement. (For this example, assume this dimension equals 3.550").

CAUTION: In taking this dimension in this step and in each succeeding step, always locate the shaft and take dimension from same spot on end of shaft.

- d. Remove main bearing cap.
- e. On 19C3, 4 and 5 with the new style bearing pedestal and on all 19C6, 7 and 8 machines, it will be necessary to remove the thrust ring seat assembly and base ring assembly. In addition, remove the lower half of the journal bearing and invert it so that the counter-thrust face is towards the motor. This will permit shaft float great enough to allow the second stage impeller to strike the volute wall.
- f. Force the shaft toward the compressor as far as it will go. Measure and record the distance from the end of the shaft to the set-up bar. (Assume 3.600").
- g. Subtract measurement in step (c) from step (f) above. $3.600'' - 3.550'' = .050''$. This dimension checks with the desired clearance in front of the second stage impeller and is satisfactory.
- h. Force the shaft all the way towards the motor end. Measure and record the distance from the end of the shaft to the set-up bar. (assume 3.465".)
- i. Subtract measurement obtained in (h) from measurement obtained in (c) to get clearance behind second stage impeller. $3.550'' - 3.465'' = .085''$. This is greater than .070" and therefore the clearance behind the second stage impeller is satisfactory.



SERVICE BULLETIN

SUPERSEDE
BULLETIN:
DATE:
PAGE: OF:

STEP NO. 4 - SPACING THE FIRST STAGE IMPELLER

- a. Reinstall thrust and journal bearing to its normal operating position.
- b. Install diaphragm on to volute. Check concentricity of diaphragm with shaft by rotating a dial indicator from the shaft to the first stage labyrinth "land". This should be within .002" TIR.
- c. Place intake wall face down on the floor. (See figure 6) Place first stage impeller inside the intake wall.
- d. Place the straight edge across the impeller labyrinth ring while centering the impeller within the intake wall. Center the impeller until dimension "E" checks within .003" taken at several positions around the intake wall flange.
- e. Measure and record dimensions "D" and "E".
- f. With thrust bearing installed, force the shaft towards the compressor end until the thrust ring rides on thrust bearing.
- g. Place straightedge against diaphragm as shown in figure 4.
- h. Measure and record dimensions "F" and "G".
- i. The spacer length between the first and second stage impellers can be found by following an example:
 - "D" Straightedge to impeller hub = .860"
 - "E" Straightedge to intake wall flange = .197"
 - "F" Straightedge to 2nd stage = 6.892"
 - "G" Straightedge to volute flange = 1.905"

The desired clearance in front of first stage impeller is 0.050" (should be between 0.045" - 0.055").

 - 1. "E" plus desired clearance (.197 + 0.050) = .247"
 - 2. "F" minus "G" (6.892" - 1.905") = 4.987"
 - 3. "D" minus results in 1 above (.860" - .247") = 0.613"
 - 4. Result in 3 above plus result in 2 above (0.613" + 4.987) = 5.600"
 - 5. Spacer length = 5.600"
- j. If machining of spacer is required, repeat above steps to double check. Check spacer carefully after obtaining the proper length. Spacer ends must be parallel within .0005" to insure proper "seating" of first stage impeller. If necessary, add shims to get desired spacer length.
- k. Apply a little white lead to inside of spacer and install over shaft.
- l. Install shaft labyrinth. With a feeler gauge, check dimension between spacer and shaft labyrinth. This should be .008" - .014" all around.
- m. Lay the first stage impeller face down and fit the labyrinth to the labyrinth ring. The dimension between the labyrinth and ring should be .012" - .020" all around.



**UNITED
TECHNOLOGIES
CARRIER**

Commercial Division
Carrier Corporation

BULLETINCA-SB-19-C-60-7
DATE: 4/20/60
PAGE: 7 OF: 16

SERVICE BULLETIN

SUPERSEDE
BULLETIN:
DATE:
PAGE: OF:

- n. Install first stage impeller labyrinth on to diaphragm.
- o. With the dial indicator linkage on the shaft and the dial on the labyrinth blades, (use wide dial button) check concentricity of labyrinth to shaft by rotating the shaft slowly. Concentricity should be within .004" TIR.
- p. Before installing the first stage impeller, examine the keys and keyways. Be sure keyways, keys and impeller hub bore are free of burrs.
- q. The keys should fit snug in the keyways.
- r. Apply a light coat of white lead to the 1st stage impeller hub. Install 1st stage impeller similar to 2nd stage impeller above using wheel puller in pushing position.
- s. After installing first stage impeller, rotate shaft and listen for any rubbing.
- t. Install compressor intake wall.

STEP NO. 5 - CHECKING FIRST STAGE IMPELLER CLEARANCE

- a. The front and back clearance of the first stage impeller can be checked as outlined in Step No. 3 by floating the shaft. If the front clearance is less than 0.050", then you know the front of the first stage impeller is hitting first. A similar check can be made for the back of the impeller.
- b. With a long thickness gauge, check clearance of each blade to inlet ring. This should be 0.035" to 0.050".
- c. Replace thrust bearing to its normal running position and turn shaft by hand to check for rubbing or interference.
- d. Install the nose cone and stud, centering each on the shaft with a dial indicator.
- e. Install the compressor inlet venturi . _____

SERVICE BULLETIN

SUPERSEDE
BULLETIN:
DATE:
PAGE: OF:

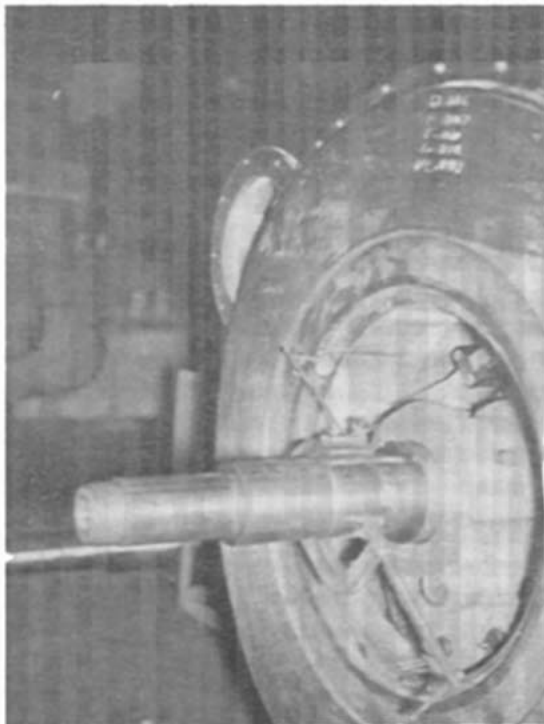

PHOTO #1

DIAL INDICATOR IN POSITION TO CHECK SHAFT
CONCENTRICITY.



PHOTO #2

DIAL INDICATOR IN POSITION TO CHECK SHAFT
"RUN-OUT".



**UNITED
TECHNOLOGIES
CARRIER**

Commercial Division
Carrier Corporation

BULLETIN: CA-SB-19-C-60-7

DATE: 4/20/60

PAGE: 9 OF: 16

SERVICE BULLETIN

SUPERSEDE

BULLETIN:

DATE:

PAGE: OF:

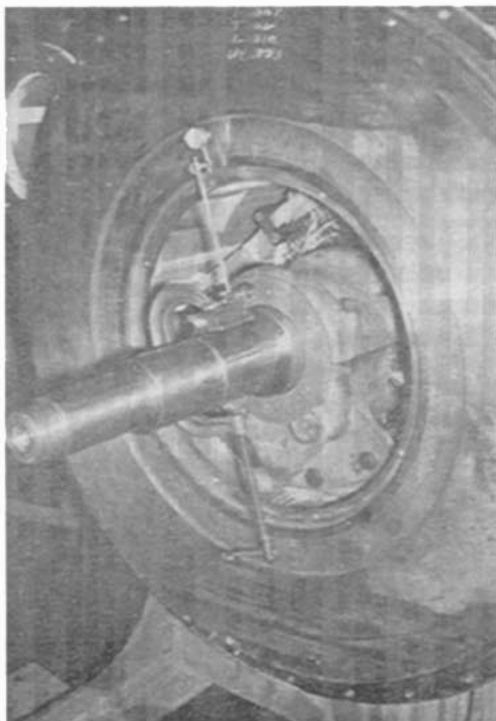
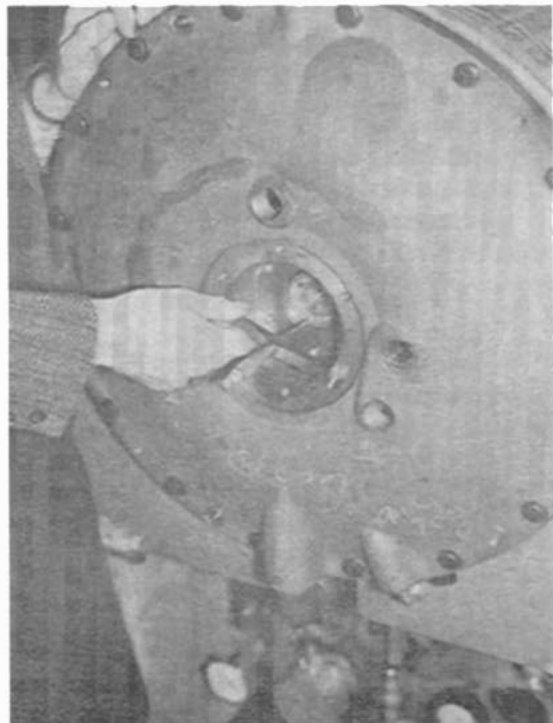

PHOTO #3

DIAL INDICATOR AGAINST SHELL FLANGE "FACE"
TO CHECK SHAFT "SQUARENESS".

PHOTO #4

DEPTH MICROMETER CHECKING SHAFT "FLOAT" (NEW
STYLE END BELL).



SERVICE BULLETIN

SUPERSEDE
BULLETIN:
DATE:
PAGE: OF:

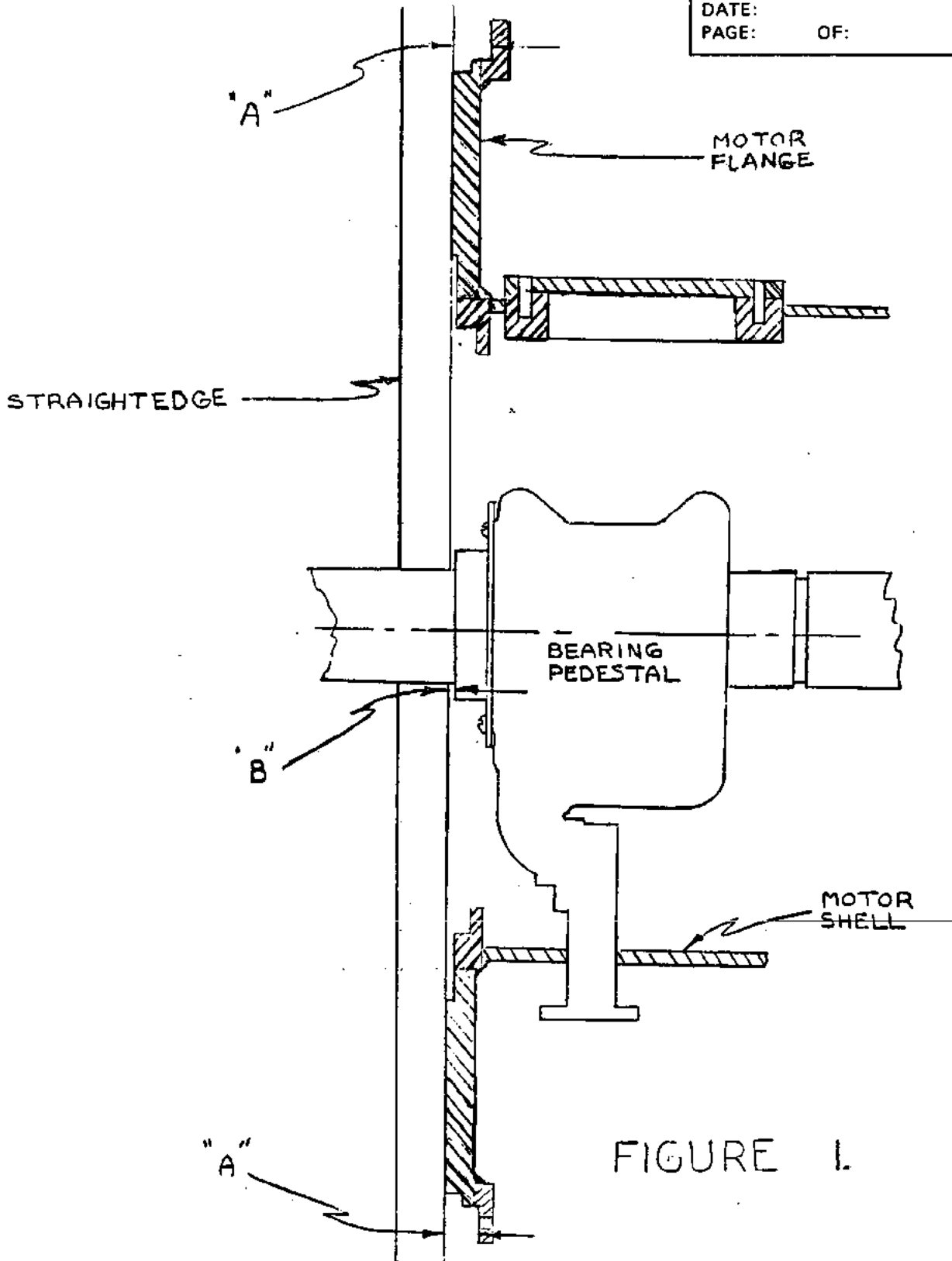

FIGURE 1.



SERVICE BULLETIN

SUPERSEDE
BULLETIN:

DATE:
PAGE: OF:

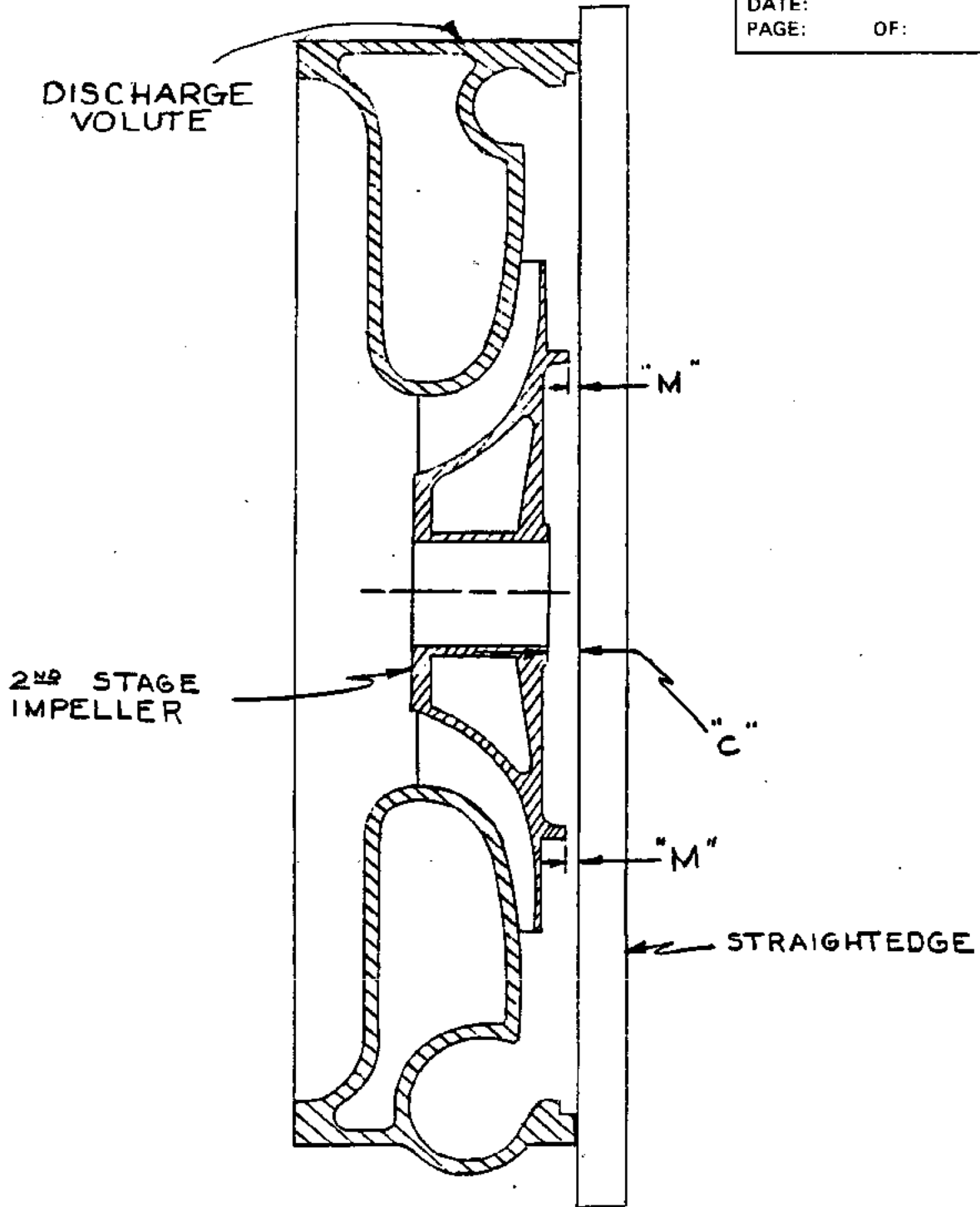

FIGURE 2

SERVICE BULLETIN

SUPERSEDE
BULLETIN:
DATE:
PAGE: OF:

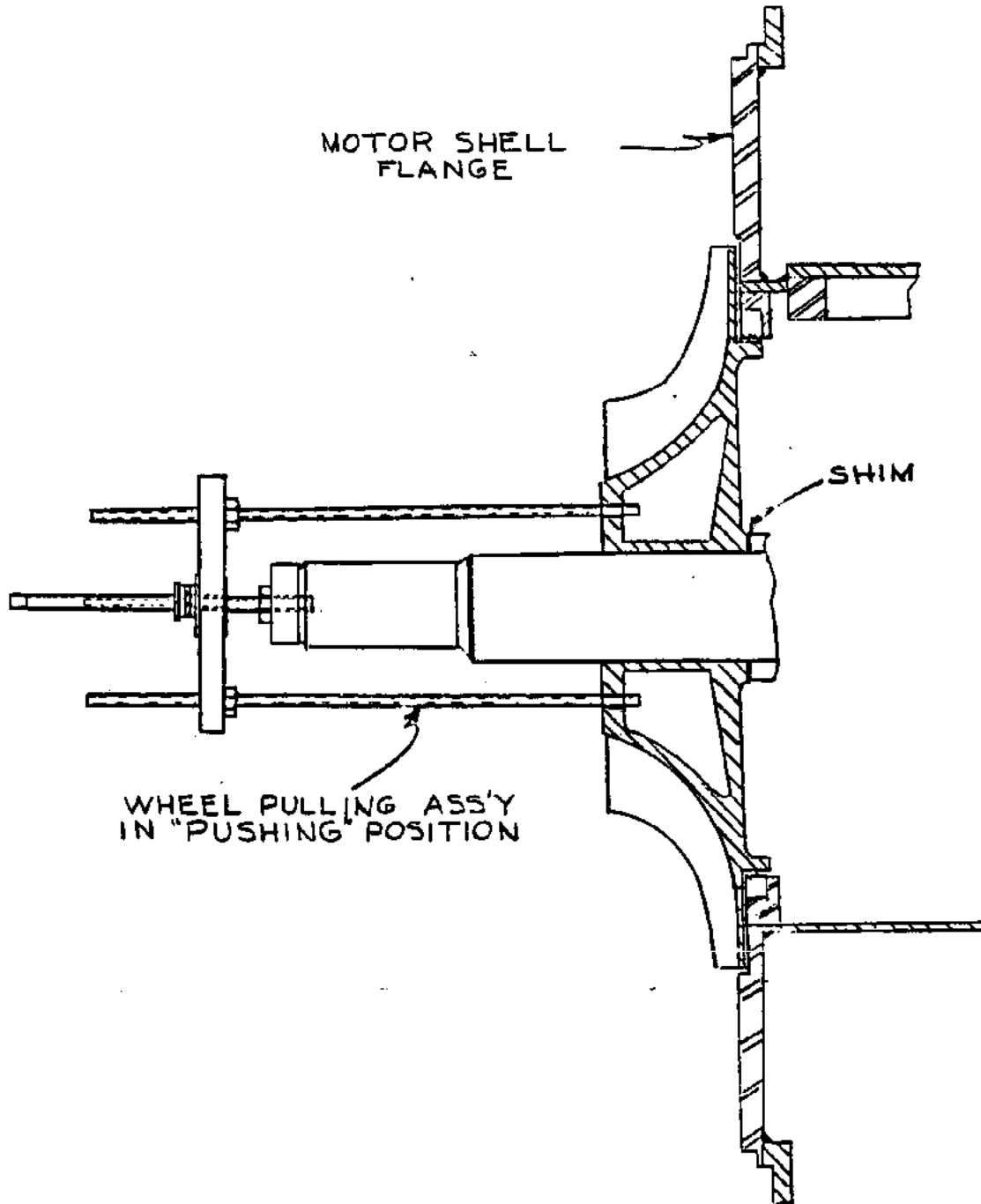

FIGURE 3



**UNITED
TECHNOLOGIES
CARRIER**

Commercial Division
Carrier Corporation

BULLETIN: CA-SB-19-C-60-7

DATE: 4/20/60

PAGE: 13 OF: 16

SERVICE BULLETIN

SUPERSEDE

BULLETIN:

DATE:

PAGE: OF:

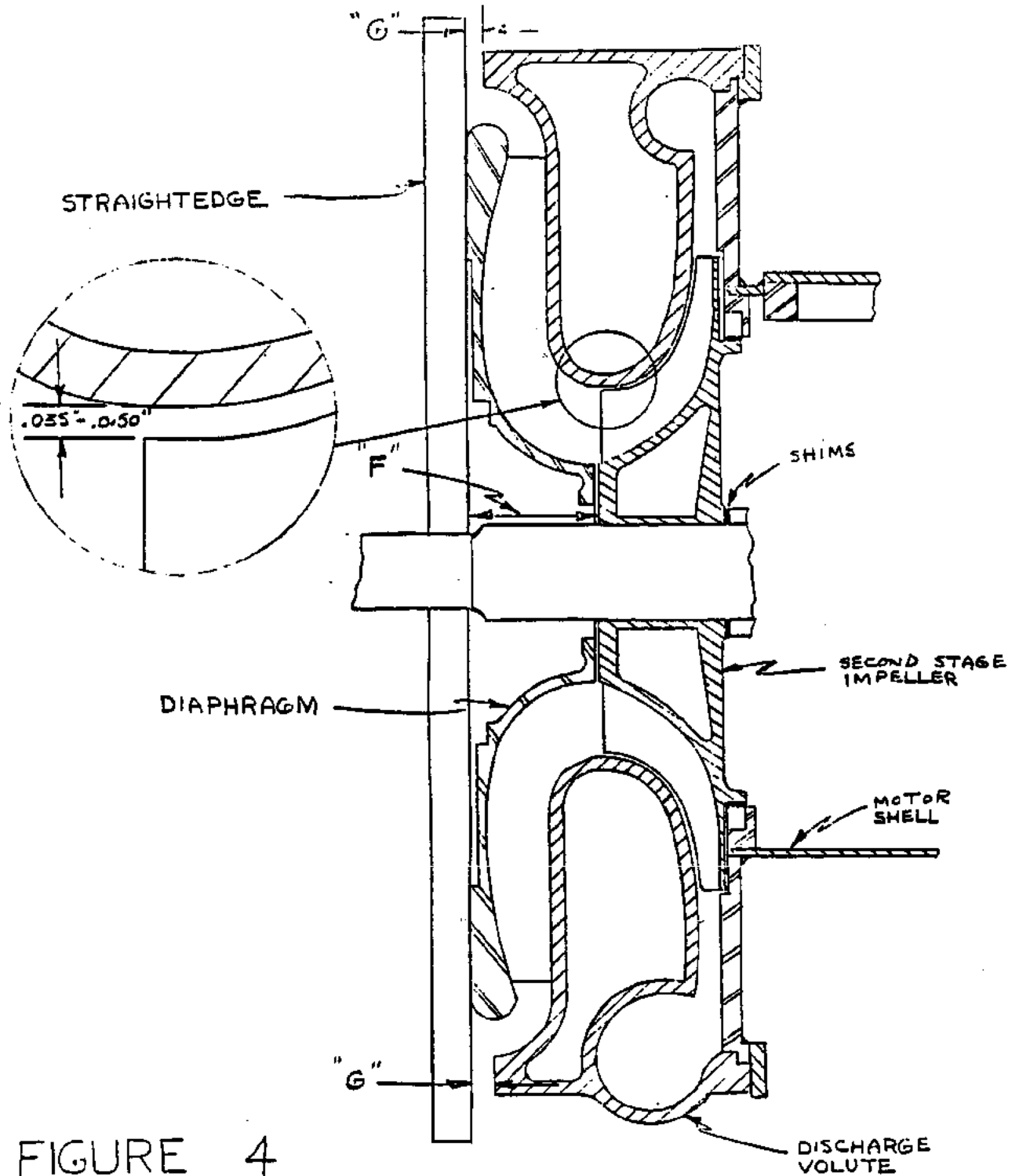

FIGURE 4

SERVICE BULLETIN

SUPERSEDE
BULLETIN:
DATE:
PAGE: OF:

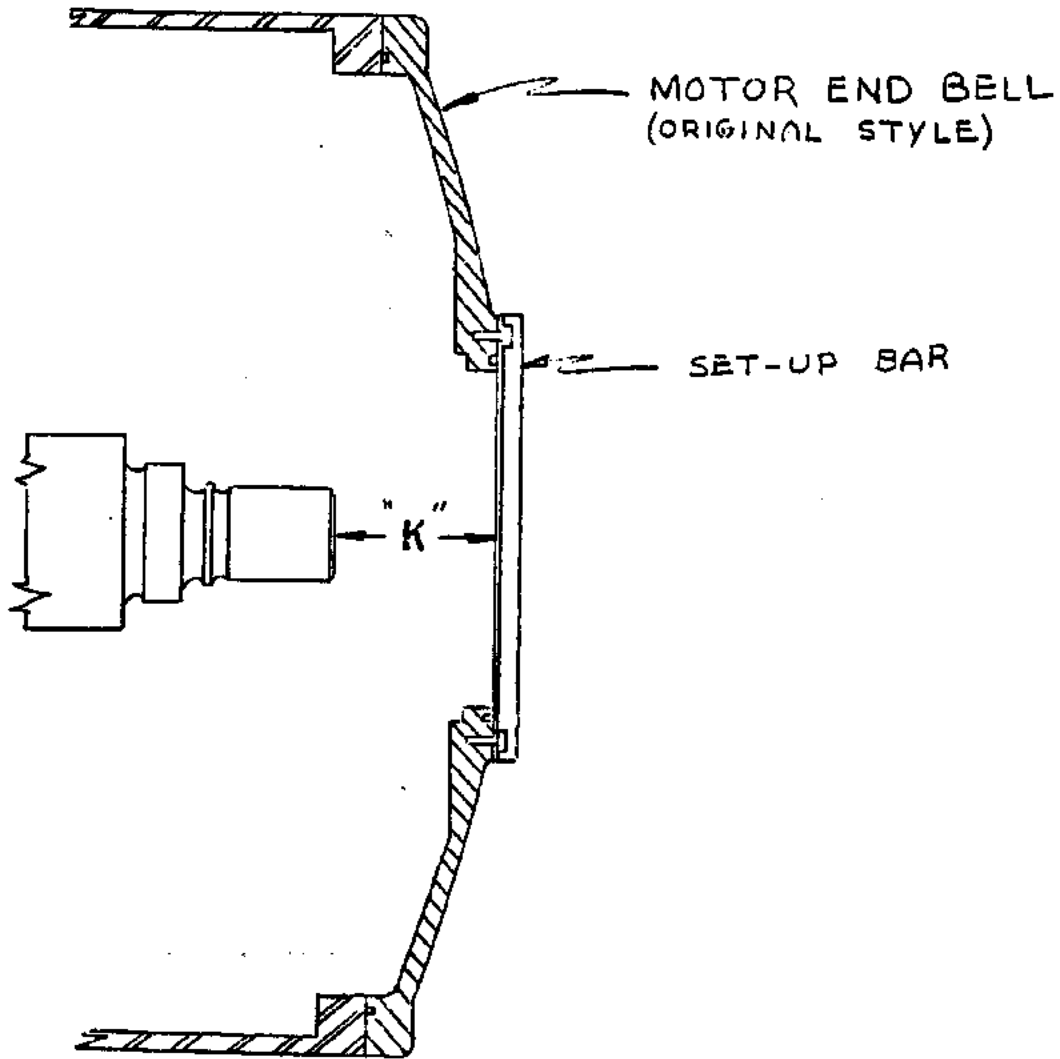
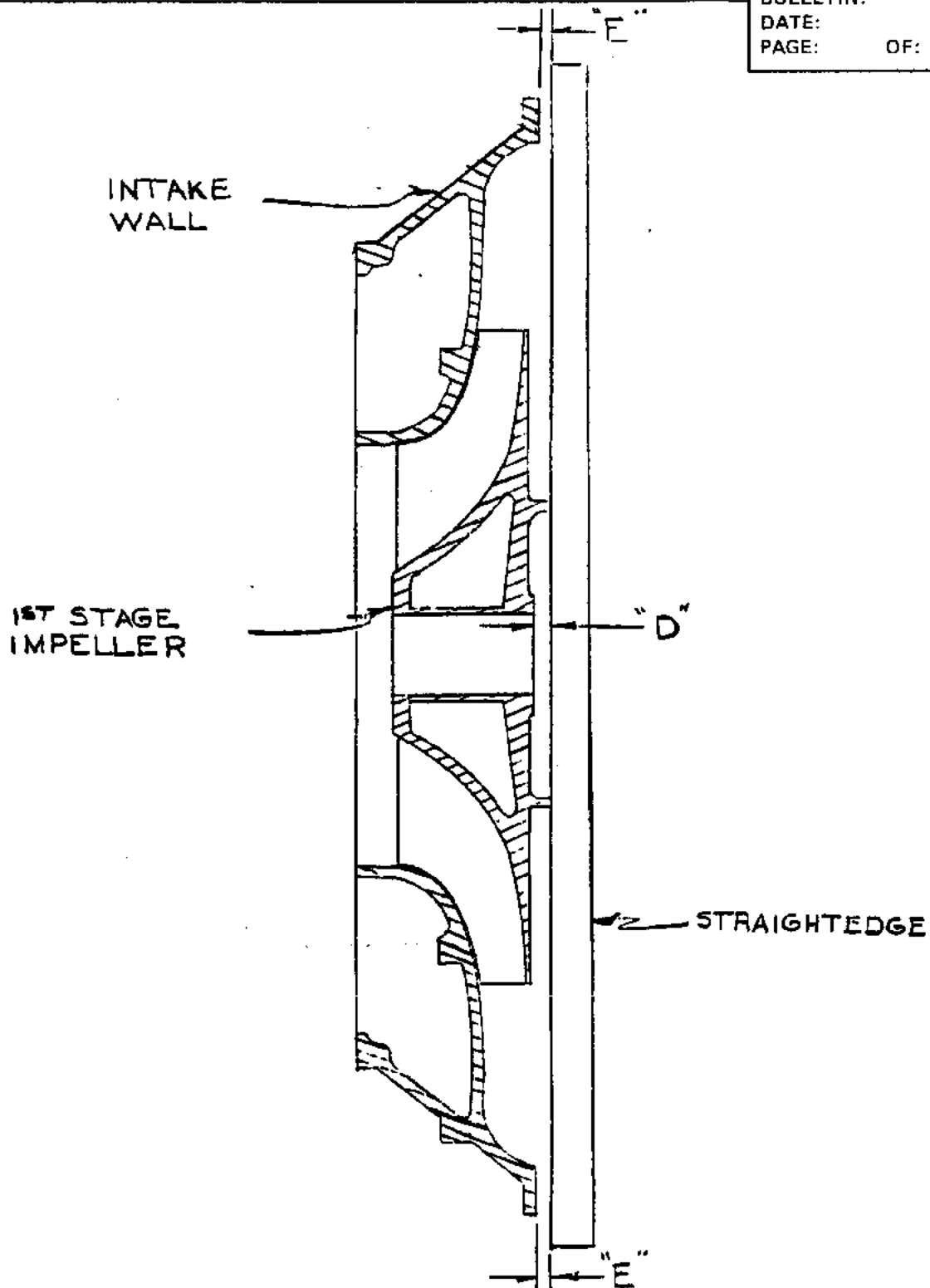

FIGURE 5



SERVICE BULLETIN

SUPERSEDE
BULLETIN:
DATE:
PAGE: OF:





UNITED TECHNOLOGIES
CARRIER

Commercial Division
Carrier Corporation

SERVICE BULLETIN

BULLETIN: CA-SB-19-C-60-7
DATE: 4/20/60
PAGE: 16 OF: 16

SUPERSEDE
BULLETIN:
DATE:
PAGE: OF:

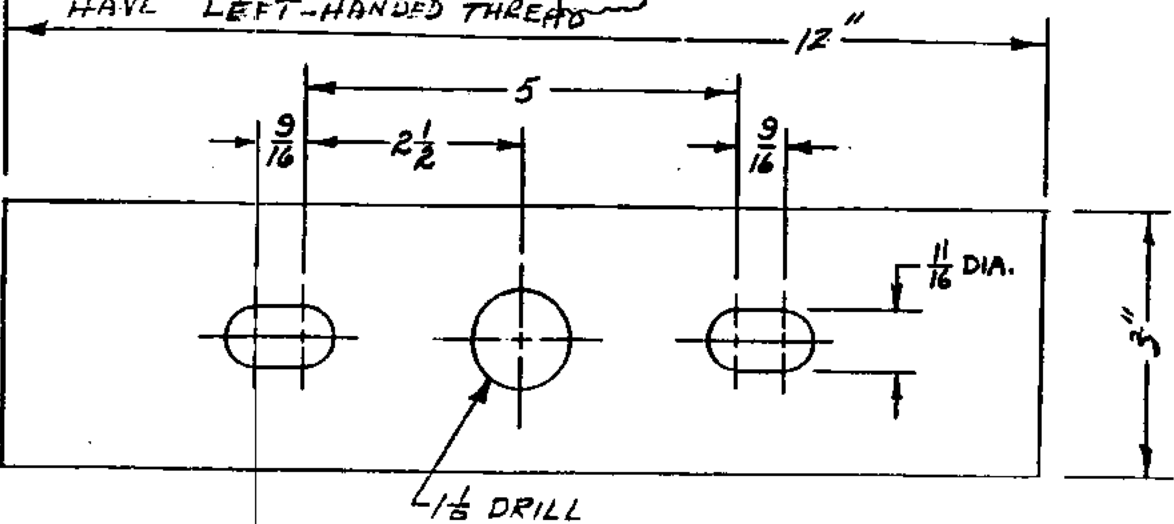
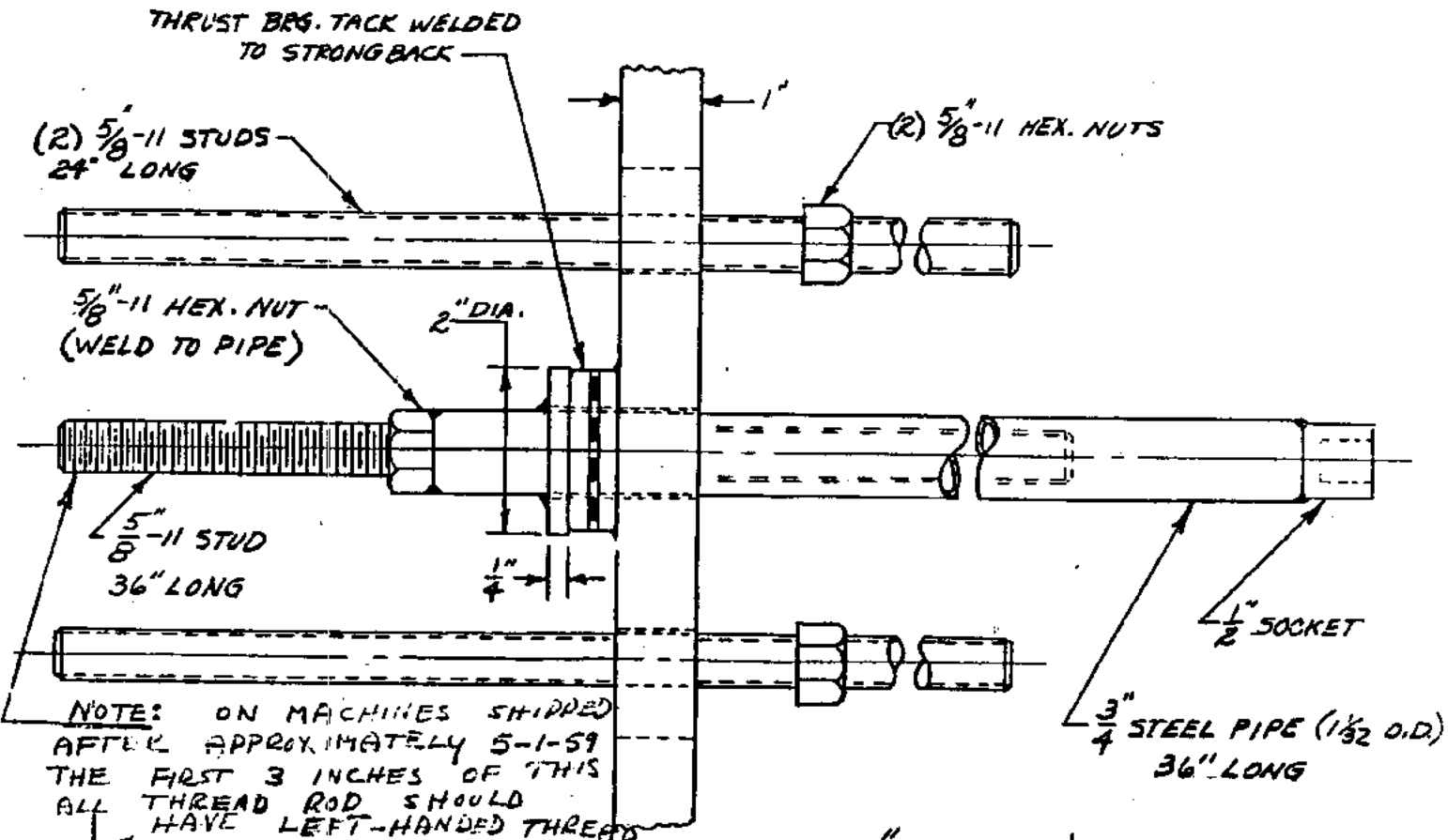

SHEET PULLING ASSEMBLY
19C CENTRIFUGAL

FIGURE 7