

Insulation

YORK recommends that all absorption equipment be insulated properly to optimize operating performance, insure the safety of operating and plant personnel, prevent sweating, and to prevent crystallization up to eight hours during a power failure. YORK performance ratings are based on a properly insulated chiller. Proper insulation limits the heat loss from the chiller to its surroundings. Insulation also protects personnel from the hot surfaces, such as the generator shell and steam piping and is often required for safety codes. Lastly, insulation when applied properly, will prevent crystallization during a power failure for up to eight hours with a minimum room temperature of 70°F.

Insulating an absorption chiller requires special consideration to three separate sections of the chiller: hot, cold and intermediate temperature surfaces. By insulating the hot surfaces, heat loss to the equipment room is minimized thereby maximizing efficiency and preventing hazardous working conditions. Cold insulation is applied to a chiller to prevent sweating. When a chiller is operating, moisture in the surrounding air may condense on the surface of the evaporator and refrigerant side and collect on the equipment room floor causing unsafe conditions. The last critical area for insulation are areas that contain weak lithium bromide solution. These areas are more susceptible to crystallization when their temperature lowers. A properly insulated chiller will provide safe, reliable and efficient operation throughout the life of the equipment.

For hot surfaces, YORK recommends using 2 inch thick 3 lb. density fiberglass insulation. Hot surfaces that need insulation are the generator and connecting piping, solution heat exchangers and solution piping. These areas are filled in with a charcoal gray in the insulation drawings located at the end of this section.

For cold surfaces, YORK recommends

using 3/4 inch closed-cell foam insulation. Cold surfaces that need foam insulation are the evaporator shell, refrigerant piping, refrigerant pumps and the refrigerant tank. Cold surfaces are indicated on the insulation drawings with a light gray color.

For intermediate temperature surfaces, YORK recommends using 1 inch thick 2 lb. density fiberglass insulation. These surfaces include the absorber pumps and piping. The intermediate surfaces, marked with a medium gray color on the insulation diagrams, must be insulated to help prevent crystallization.

Insulation Tips

Before insulating an absorption chiller, see the “Do’s and Don’ts” section below for some helpful hints and warnings about applying insulation.

Insulation must **not** be applied to the chiller until start-up has been successfully completed by a qualified YORK service technician. Apply removable insulation to chiller surfaces that must be removed for servicing. The surfaces of the chiller that must have removable insulation include the refrigerant and solution pump motors, valves, sight glasses, thermowells, isolation valves, flanges and other piping connections. For detailed insulation drawings, **see pages 3 through 21 in this section.**

Acceptable means of mounting insulation to the chiller surfaces include bonding agents, iron wires and bands. Insulation pins are also acceptable provided they **are not** welded to the chiller surface. A high temperature adhesive is recommended to mount the insulation to the chiller. The surface of the insulation should be sealed vapor tight to prevent sweating and mildew underneath the insulation. All seams should be filled in using insulation tape or thermal mastic compound. Aluminum facing provides an additional layer of protection and a quality finish to the job.

WARNING: Welding anything to the shell may penetrate the shell and may jeopardize the integrity of the chiller. Any welding to the chiller shell will without written consent of York Factory Service will result in voiding all warranties.

Insulation Do’s and Don’ts

DO’S

1. **DO** use removable insulation on movable parts (i.e. valve handles), valves, thermowells, sight glass view areas, flanges and pipe connections, and water box covers and bolts. These areas must be accessible for service and occasionally by operating personnel.
2. **DO** use the recommended materials and thicknesses
3. **DO** wait until the YORK service representative has performed the complete start-up procedure, the chiller has been positioned, leveled and commissioned.
4. **DO** use an acceptable means of mounting the insulation to the chiller surfaces. (i.e. bonding agents, iron wires, bands) Keep in mind that any servicing may require removal of sections of insulation.
5. **DO** use a thermal mastic or equivalent means of applying a vapor seal between insulation joints.
6. **DO** refer to the insulation drawings located at the end of this section.

DON’TS

1. **DO NOT** cover viewing area of sight glasses with insulation.
2. **DO NOT** cover chiller pipe connections, since they must be accessible for pressure and vacuum tests.
3. **DO NOT** cover pump motors with insulation. They must be allowed to radiate some of the heat to the surroundings.

4. DO NOT use weld pins to mount insulation. Table IT-1

Additional Comments

The insulation drawings at the end of this section are meant to serve as a guide for the insulation contractor before the chiller arrives on site for cost estimation and for actual installation.

Recommended insulation materials are shown in Table IT-1 at right. Table IT-2 below shows total approximate surface areas to be insulated.



	Hot Insulation	Intermediate Insulation	Cold Insulation
Material	3 lb. density fiberglass	2 lb. density fiberglass	closed-cell foam
Thickness	2 inches	1 inch	3/4 inch
Color Code on Insulation Diagrams			

Table IT-2

YORK ParaFlow™ Absorption Chiller Insulation Area (all figures in square feet)

Model Number	Direct-Fired		Steam	
	Hot	Cold	Hot	Cold
12SC	172	86		
13SC	194	86		
14SC	258	118		
15SL	355	140		
16S	355	140		
16SL	398	172	398	172
17S	398	172	398	172
18S	474	205	474	205
19S	506	237	506	237
16G	350	75		
17G	390	75		
18G	430	90		
19G	585	90		
19GL	625	150	530	150
20G	840	165	545	155
21G			635	125
22G			730	165

YORK ParaFlow™ Absorption Chiller Insulation Area (all figures in square meters)

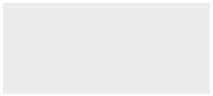
Model Number	Direct-Fired		Steam	
	Hot	Cold	Hot	Cold
12SC	16.0	8.0		
13SC	18.0	8.0		
14SC	24.0	11.0		
15SL	33.0	13.0		
16S	33.0	13.0		
16SL	37.0	16.0	37.0	16.0
17S	37.0	16.0	37.0	16.0
18S	44.0	19.1	44.0	19.1
19S	47.0	22.0	47.0	22.0
16G	32.5	7.0		
17G	36.2	7.0		
18G	40.0	8.4		
19G	54.4	8.8		
19GL	58.1	13.9	49.2	13.9
20G	78.0	15.3	50.6	14.4
21G			59.00	11.6
22G			67.8	15.3

Insulation Methods to Avoid

1. Do not insulate moving parts such as valve handles.
2. Do not insulate thermowells.
3. Do not cover sight glasses with insulation.
4. Do not cover pipe connections, since they must be accessible for pressure and vacuum tests.
5. Do not cover pump motors with insulation.
6. Do not use weld pins to attach insulation.

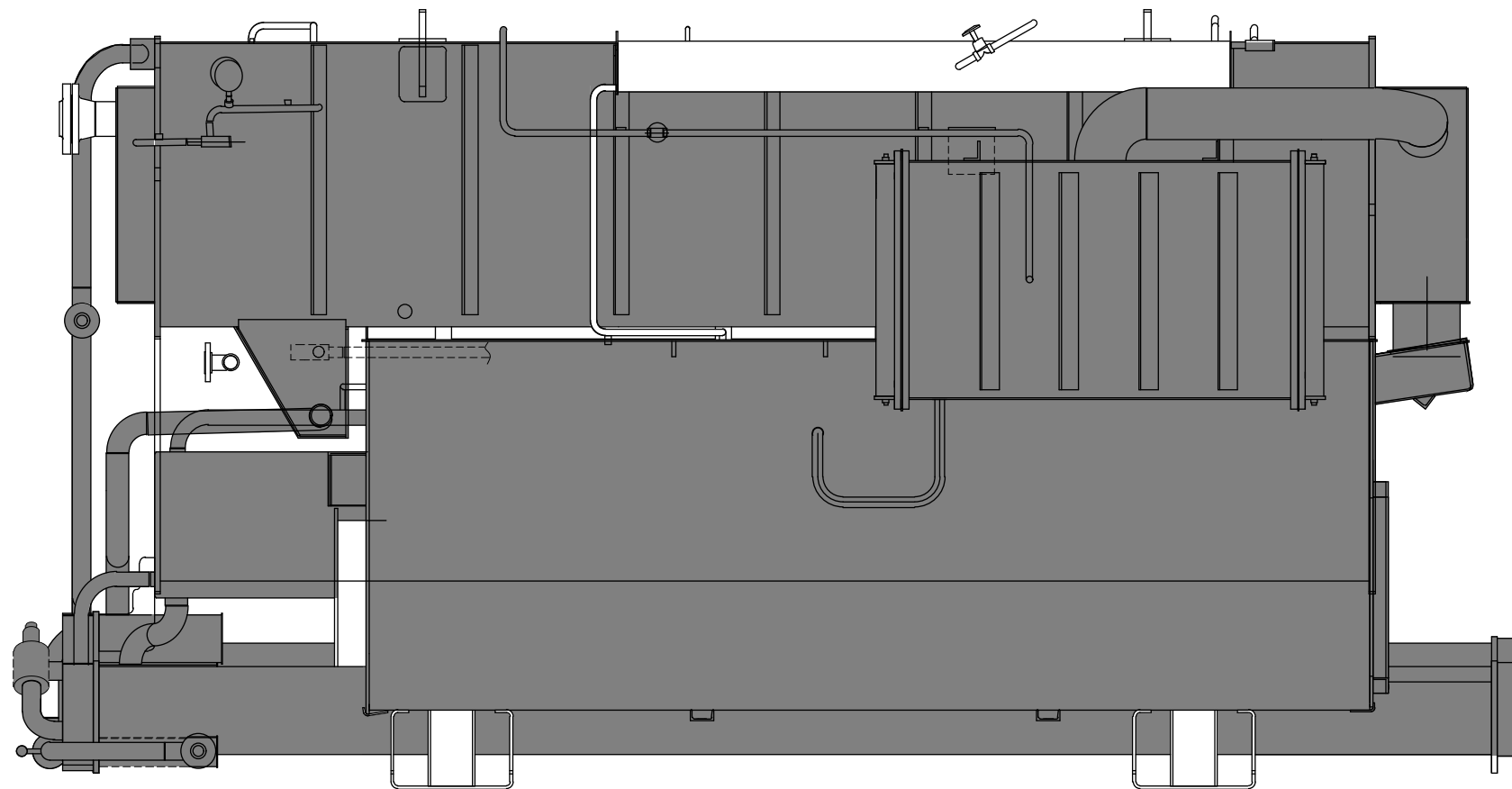

To mount insulation materials, use bonding agents, iron wires and bands. These methods do not penetrate the chiller system and jeopardize the integrity of the vacuum pressure in the chiller. **Weld pins are not acceptable.**

Proper Insulation Practices

1. Insulation on pumps, valves, sight glasses equipment and flange sections should be mounted so that it can be removed easily.
2. Water boxes or cover plates must be removed/opened from time to time for tube cleaning. Valves, pumps and nozzles must be accessible for servicing and operation.
3. Insulate auxiliary and instrument piping by wrapping glass wool around it.

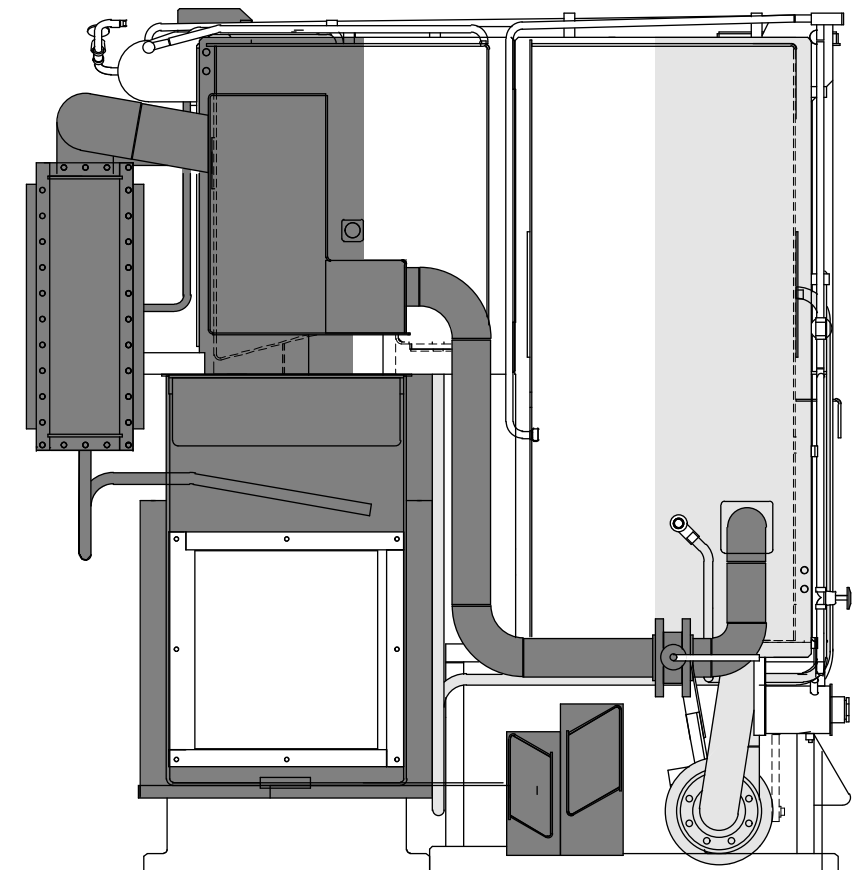
**LEGEND**

	Hot
	Intermediate
	Cold

Insulation Methods to Avoid

1. Do not insulate moving parts such as valve handles.
2. Do not insulate thermowells.
3. Do not cover sight glasses with insulation.
4. Do not cover pipe connections, since they must be accessible for pressure and vacuum tests.
5. Do not cover pump motors with insulation.
6. Do not use weld pins to attach insulation.

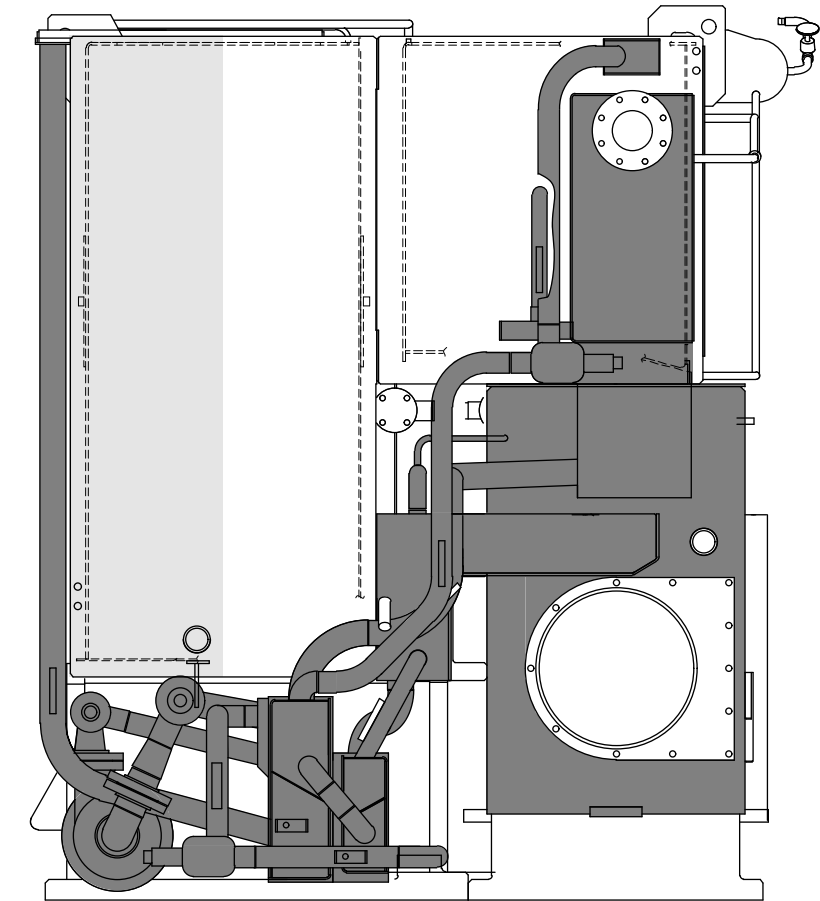
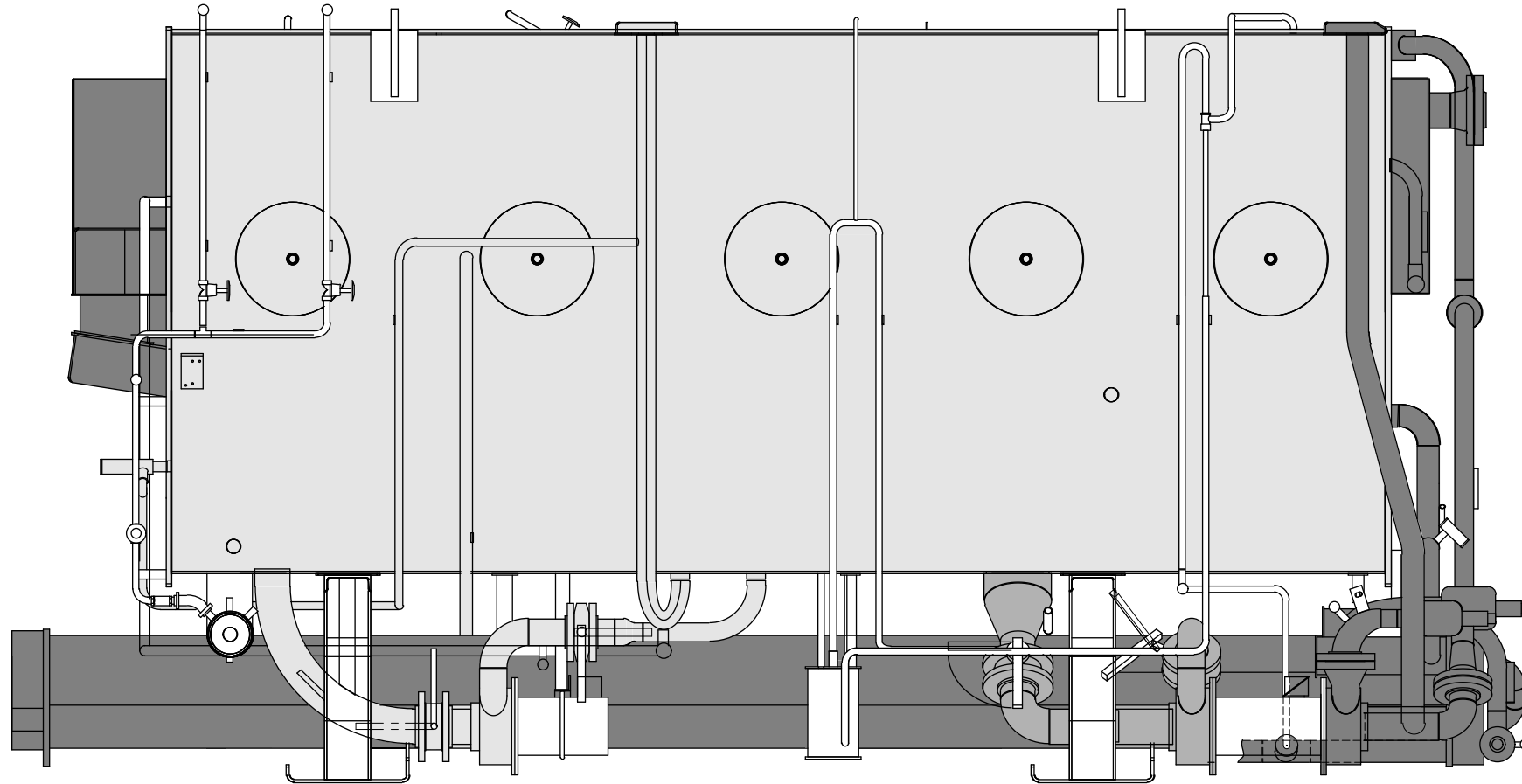

To mount insulation materials, use bonding agents, iron wires and bands. These methods do not penetrate the chiller system and jeopardize the integrity of the vacuum pressure in the chiller. **Weld pins are not acceptable.**

Proper Insulation Practices

1. Insulation on pumps, valves, sight glasses equipment and flange sections should be mounted so that it can be removed easily.
2. Water boxes or cover plates must be removed/opened from time to time for tube cleaning. Valves, pumps and nozzles must be accessible for servicing and operation.
3. Insulate auxiliary and instrument piping by wrapping glass wool around it.

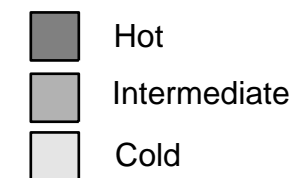
LEGEND

Insulation Methods to Avoid

1. Do not insulate moving parts such as valve handles.
2. Do not insulate thermowells.
3. Do not cover sight glasses with insulation.
4. Do not cover pipe connections, since they must be accessible for pressure and vacuum tests.
5. Do not cover pump motors with insulation.
6. Do not use weld pins to attach insulation.

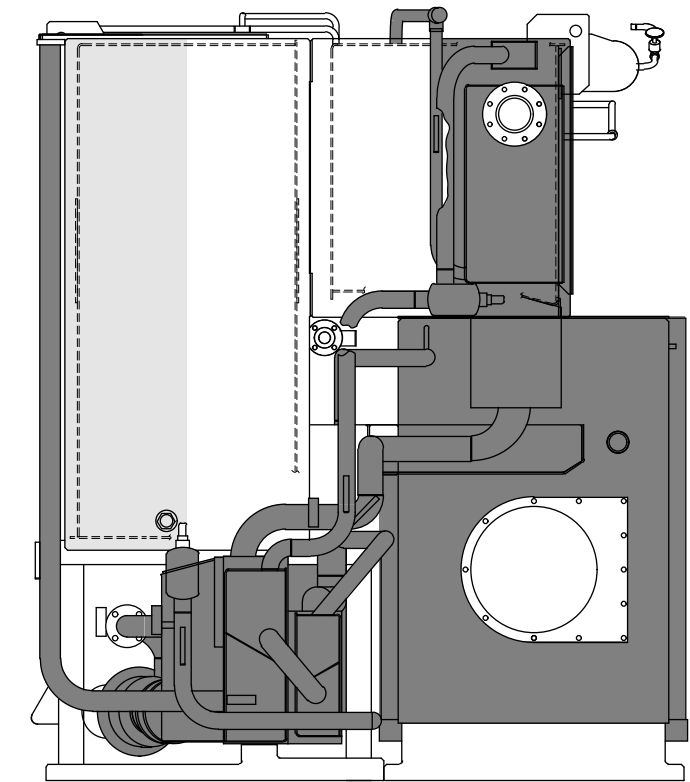
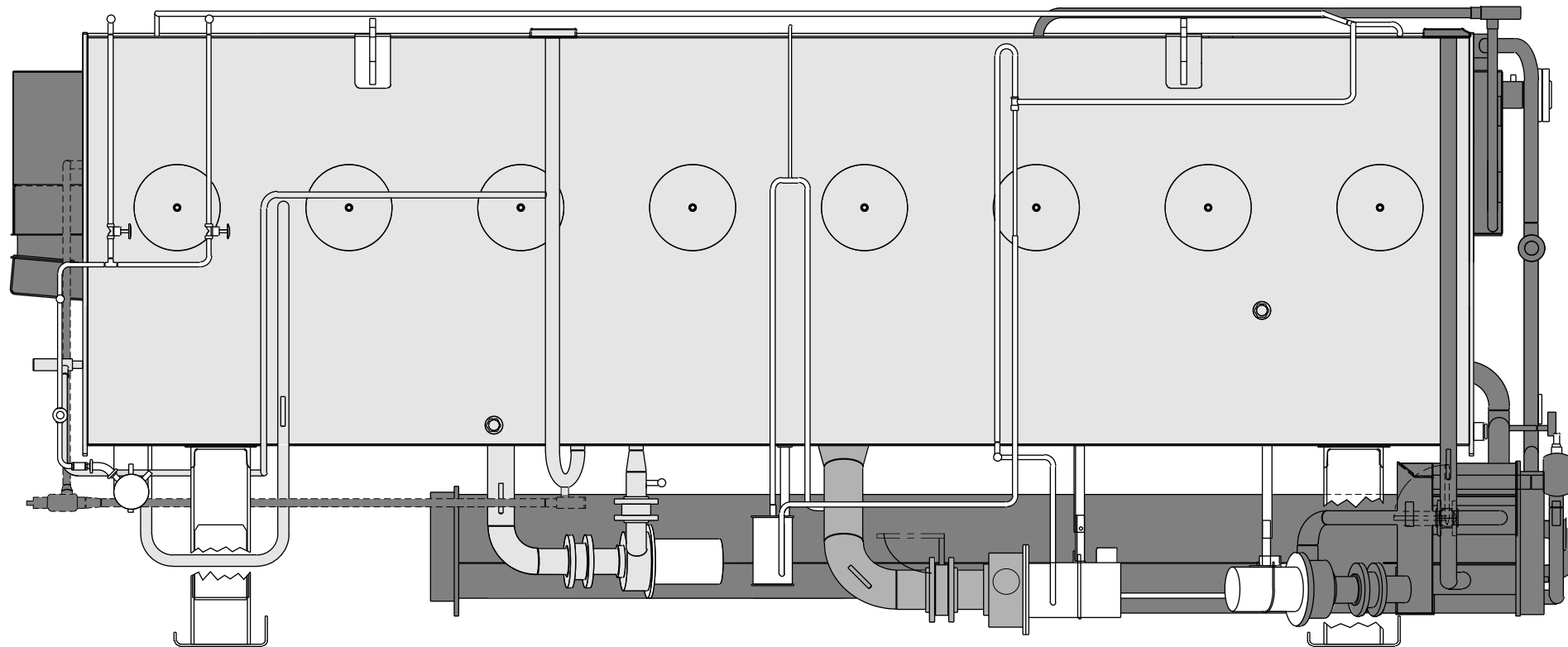

To mount insulation materials, use bonding agents, iron wires and bands. These methods do not penetrate the chiller system and jeopardize the integrity of the vacuum pressure in the chiller. **Weld pins are not acceptable.**

Proper Insulation Practices

1. Insulation on pumps, valves, sight glasses equipment and flange sections should be mounted so that it can be removed easily.
2. Water boxes or cover plates must be removed/opened from time to time for tube cleaning. Valves, pumps and nozzles must be accessible for servicing and operation.
3. Insulate auxiliary and instrument piping by wrapping glass wool around it.

LEGEND

	Hot
	Intermediate
	Cold

Insulation Methods to Avoid

1. Do not insulate moving parts such as valve handles.
2. Do not insulate thermowells.
3. Do not cover sight glasses with insulation.
4. Do not cover pipe connections, since they must be accessible for pressure and vacuum tests.
5. Do not cover pump motors with insulation.
6. Do not use weld pins to attach insulation.

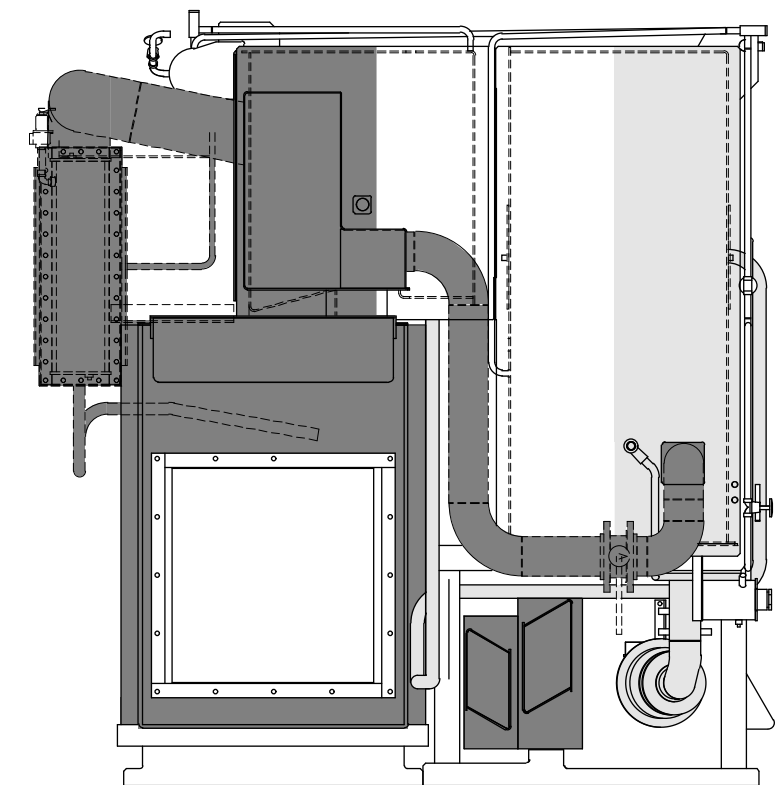
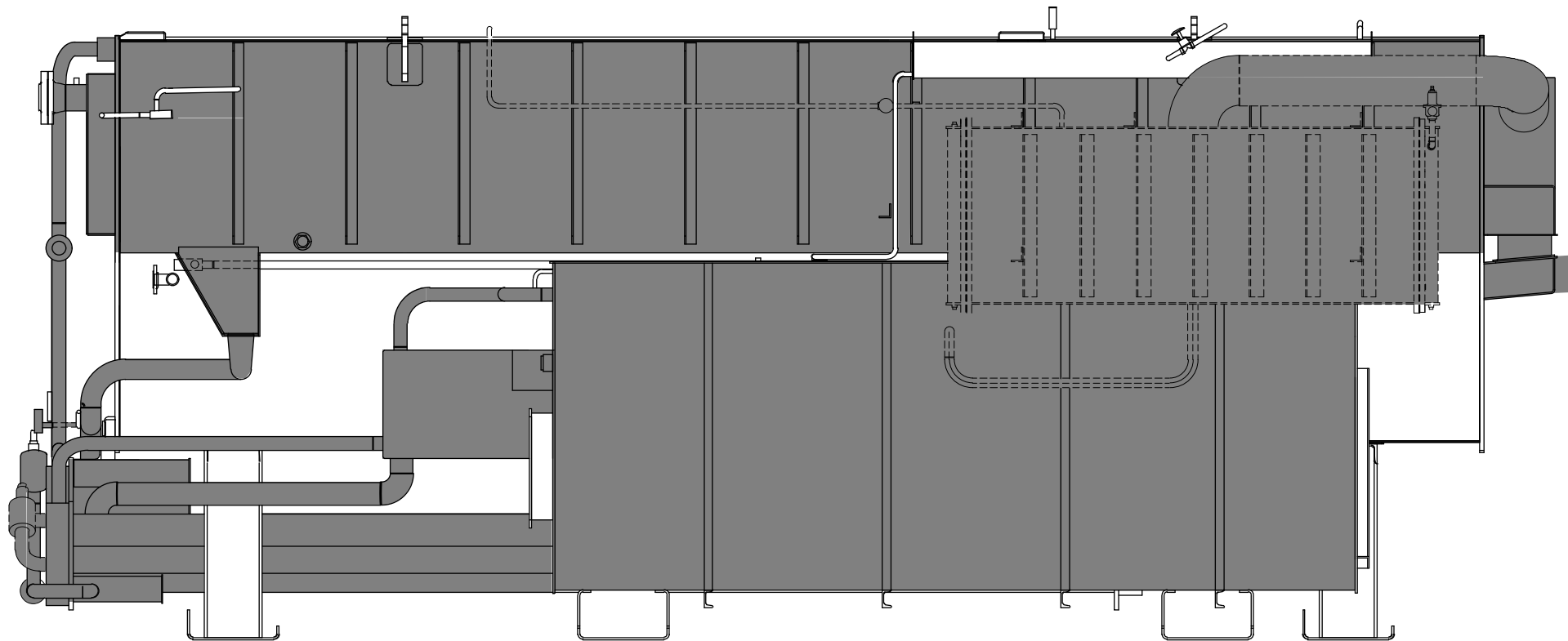

To mount insulation materials, use bonding agents, iron wires and bands. These methods do not penetrate the chiller system and jeopardize the integrity of the vacuum pressure in the chiller. **Weld pins are not acceptable.**

Proper Insulation Practices

1. Insulation on pumps, valves, sight glasses equipment and flange sections should be mounted so that it can be removed easily.
2. Water boxes or cover plates must be removed/opened from time to time for tube cleaning. Valves, pumps and nozzles must be accessible for servicing and operation.
3. Insulate auxiliary and instrument piping by wrapping glass wool around it.

LEGEND

	Hot
	Intermediate
	Cold

Insulation Methods to Avoid

1. Do not insulate moving parts such as valve handles.
2. Do not insulate thermowells.
3. Do not cover sight glasses with insulation.
4. Do not cover pipe connections, since they must be accessible for pressure and vacuum tests.
5. Do not cover pump motors with insulation.
6. Do not use weld pins to attach insulation.

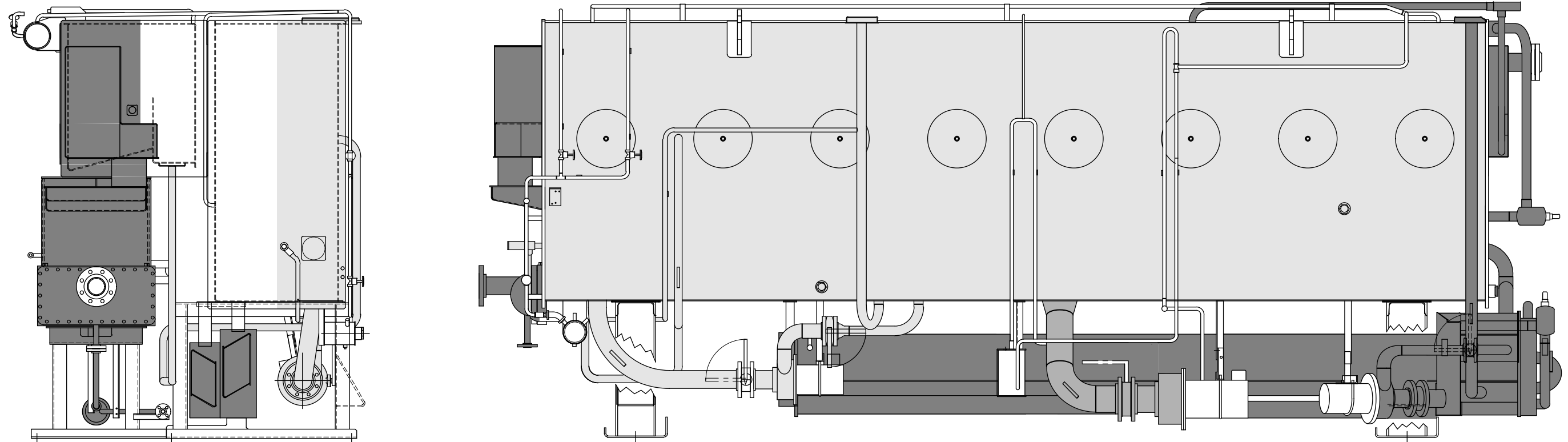

To mount insulation materials, use bonding agents, iron wires and bands. These methods do not penetrate the chiller system and jeopardize the integrity of the vacuum pressure in the chiller. **Weld pins are not acceptable.**

Proper Insulation Practices

1. Insulation on pumps, valves, sight glasses equipment and flange sections should be mounted so that it can be removed easily.
2. Water boxes or cover plates must be removed/opened from time to time for tube cleaning. Valves, pumps and nozzles must be accessible for servicing and operation.
3. Insulate auxiliary and instrument piping by wrapping glass wool around it.

LEGEND

	Hot
	Intermediate
	Cold

Insulation Methods to Avoid

1. Do not insulate moving parts such as valve handles.
2. Do not insulate thermowells.
3. Do not cover sight glasses with insulation.
4. Do not cover pipe connections, since they must be accessible for pressure and vacuum tests.
5. Do not cover pump motors with insulation.
6. Do not use weld pins to attach insulation.

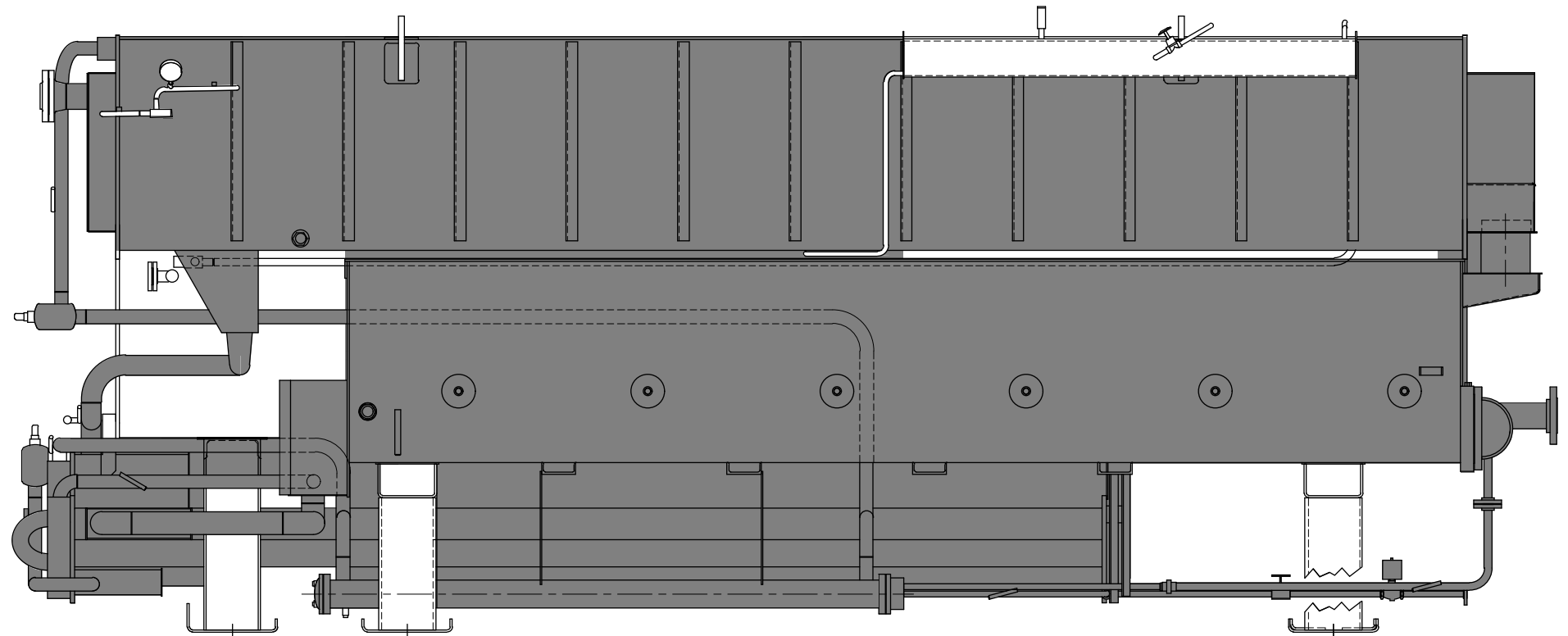
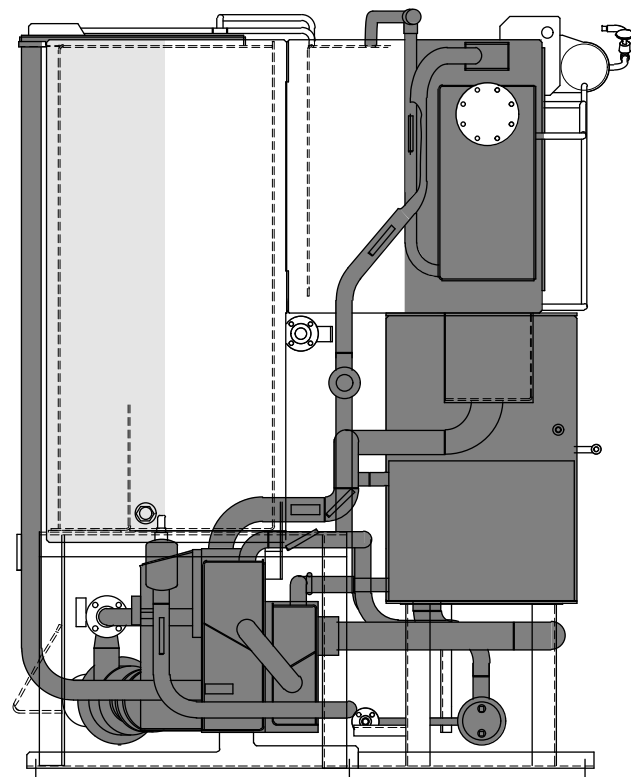

To mount insulation materials, use bonding agents, iron wires and bands. These methods do not penetrate the chiller system and jeopardize the integrity of the vacuum pressure in the chiller. **Weld pins are not acceptable.**

Proper Insulation Practices

1. Insulation on pumps, valves, sight glasses equipment and flange sections should be mounted so that it can be removed easily.
2. Water boxes or cover plates must be removed/opened from time to time for tube cleaning. Valves, pumps and nozzles must be accessible for servicing and operation.
3. Insulate auxiliary and instrument piping by wrapping glass wool around it.

LEGEND

	Hot
	Intermediate
	Cold

Insulation Methods to Avoid

1. Do not insulate moving parts such as valve handles.
2. Do not insulate thermowells.
3. Do not cover sight glasses with insulation.
4. Do not cover pipe connections, since they must be accessible for pressure and vacuum tests.
5. Do not cover pump motors with insulation.
6. Do not use weld pins to attach insulation.

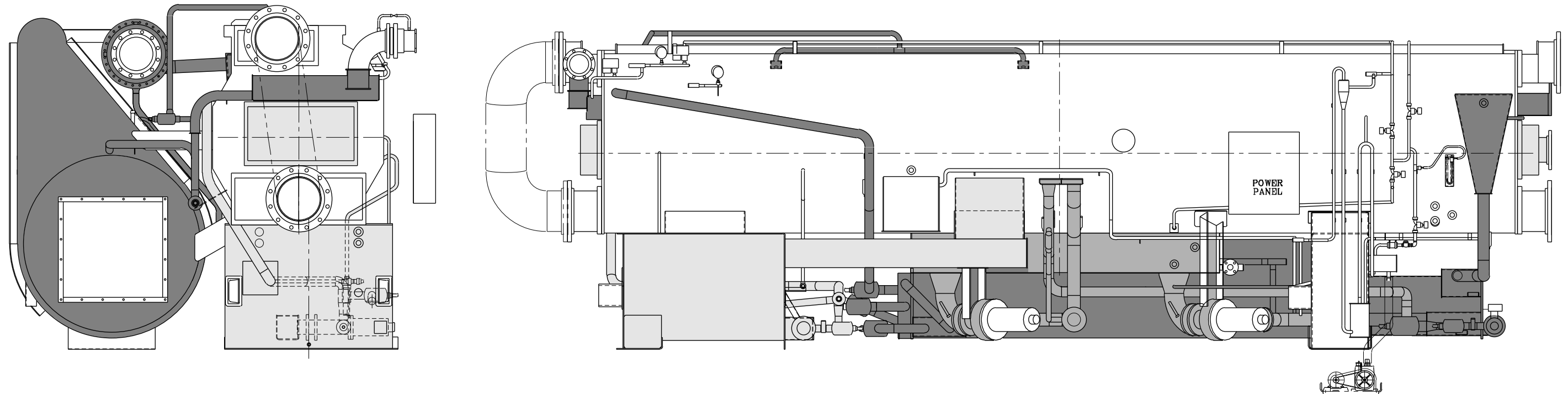

To mount insulation materials, use bonding agents, iron wires and bands. These methods do not penetrate the chiller system and jeopardize the integrity of the vacuum pressure in the chiller. **Weld pins are not acceptable.**

Proper Insulation Practices

1. Insulation on pumps, valves, sight glasses equipment and flange sections should be mounted so that it can be removed easily.
2. Water boxes or cover plates must be removed/opened from time to time for tube cleaning. Valves, pumps and nozzles must be accessible for servicing and operation.
3. Insulate auxiliary and instrument piping by wrapping glass wool around it.

LEGEND

	Hot
	Intermediate
	Cold

Insulation Methods to Avoid

1. Do not insulate moving parts such as valve handles.
2. Do not insulate thermowells.
3. Do not cover sight glasses with insulation.
4. Do not cover pipe connections, since they must be accessible for pressure and vacuum tests.
5. Do not cover pump motors with insulation.
6. Do not use weld pins to attach insulation.

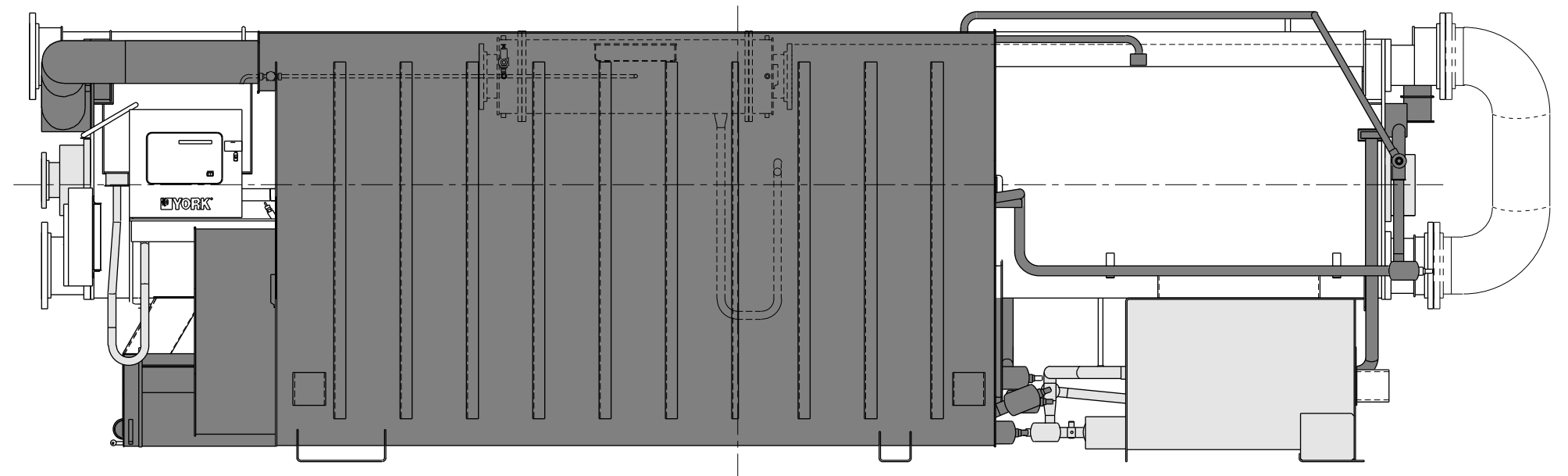
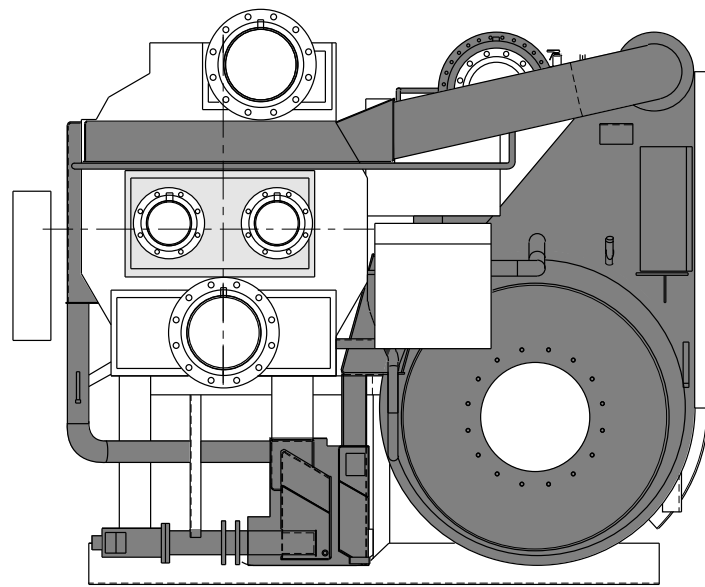

To mount insulation materials, use bonding agents, iron wires and bands. These methods do not penetrate the chiller system and jeopardize the integrity of the vacuum pressure in the chiller. **Weld pins are not acceptable.**

Proper Insulation Practices

1. Insulation on pumps, valves, sight glasses equipment and flange sections should be mounted so that it can be removed easily.
2. Water boxes or cover plates must be removed/opened from time to time for tube cleaning. Valves, pumps and nozzles must be accessible for servicing and operation.
3. Insulate auxiliary and instrument piping by wrapping glass wool around it.

LEGEND

	Hot
	Intermediate
	Cold

Insulation Methods to Avoid

1. Do not insulate moving parts such as valve handles.
2. Do not insulate thermowells.
3. Do not cover sight glasses with insulation.
4. Do not cover pipe connections, since they must be accessible for pressure and vacuum tests.
5. Do not cover pump motors with insulation.
6. Do not use weld pins to attach insulation.

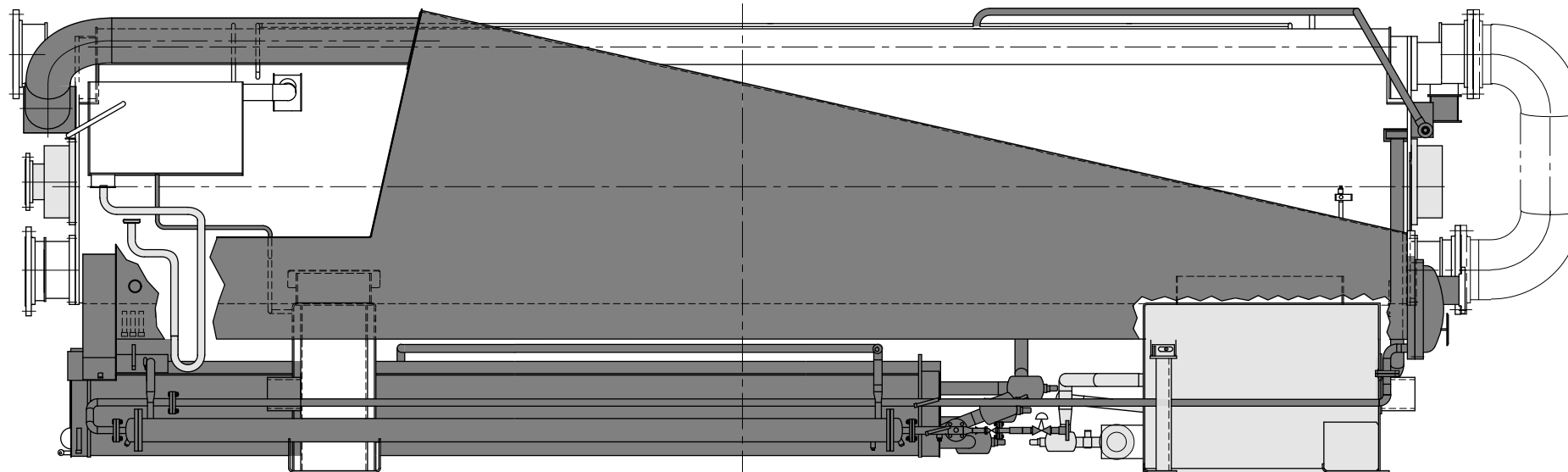



To mount insulation materials, use bonding agents, iron wires and bands. These methods do not penetrate the chiller system and jeopardize the integrity of the vacuum pressure in the chiller. **Weld pins are not acceptable.**

Proper Insulation Practices

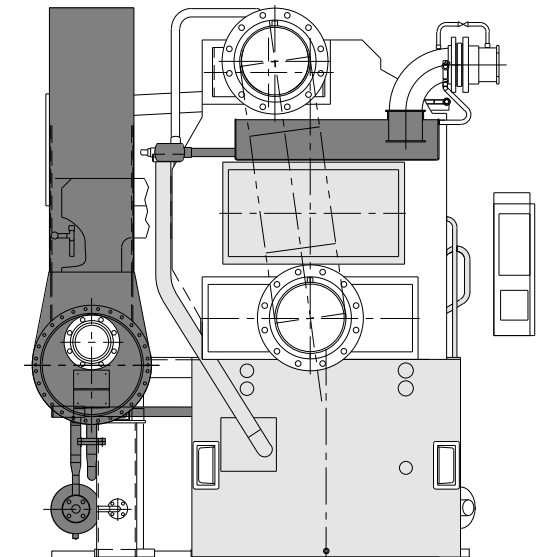
1. Insulation on pumps, valves, sight glasses equipment and flange sections should be mounted so that it can be removed easily.
2. Water boxes or cover plates must be removed/opened from time to time for tube cleaning. Valves, pumps and nozzles must be accessible for servicing and operation.
3. Insulate auxiliary and instrument piping by wrapping glass wool around it.

**LEGEND**

	Hot
	Intermediate
	Cold

Insulation Methods to Avoid

1. Do not insulate moving parts such as valve handles.
2. Do not insulate thermowells.
3. Do not cover sight glasses with insulation.
4. Do not cover pipe connections, since they must be accessible for pressure and vacuum tests.
5. Do not cover pump motors with insulation.
6. Do not use weld pins to attach insulation.

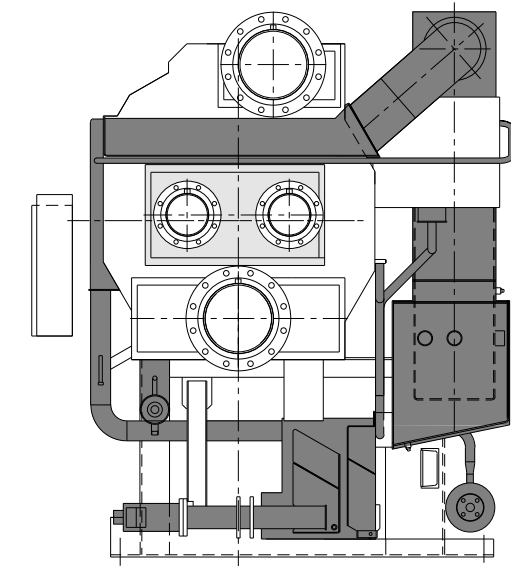
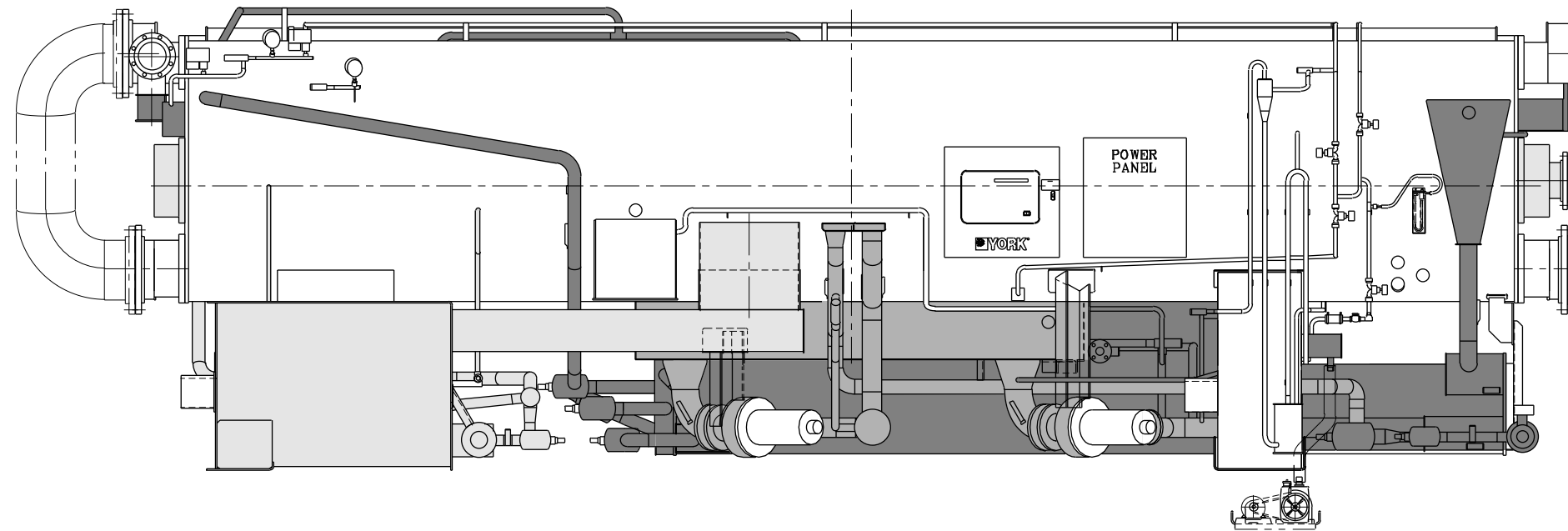

To mount insulation materials, use bonding agents, iron wires and bands. These methods do not penetrate the chiller system and jeopardize the integrity of the vacuum pressure in the chiller. **Weld pins are not acceptable.**

Proper Insulation Practices

1. Insulation on pumps, valves, sight glasses equipment and flange sections should be mounted so that it can be removed easily.
2. Water boxes or cover plates must be removed/opened from time to time for tube cleaning. Valves, pumps and nozzles must be accessible for servicing and operation.
3. Insulate auxiliary and instrument piping by wrapping glass wool around it.

LEGEND

	Hot
	Intermediate
	Cold

Insulation Methods to Avoid

1. Do not insulate moving parts such as valve handles.
2. Do not insulate thermowells.
3. Do not cover sight glasses with insulation.
4. Do not cover pipe connections, since they must be accessible for pressure and vacuum tests.
5. Do not cover pump motors with insulation.
6. Do not use weld pins to attach insulation.

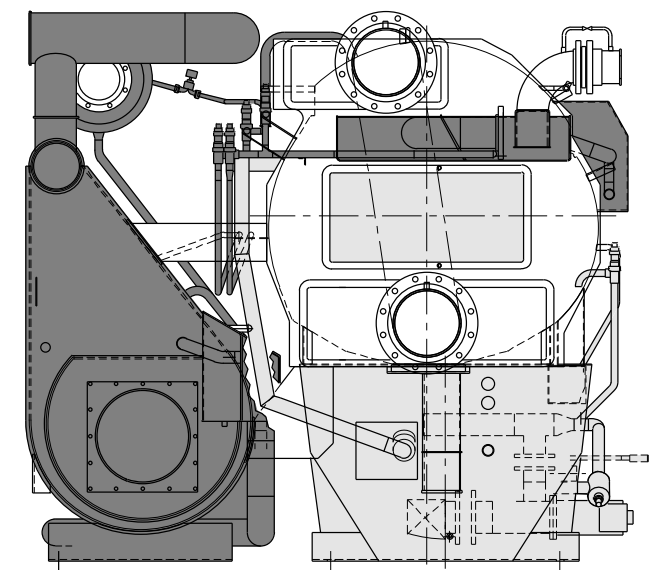
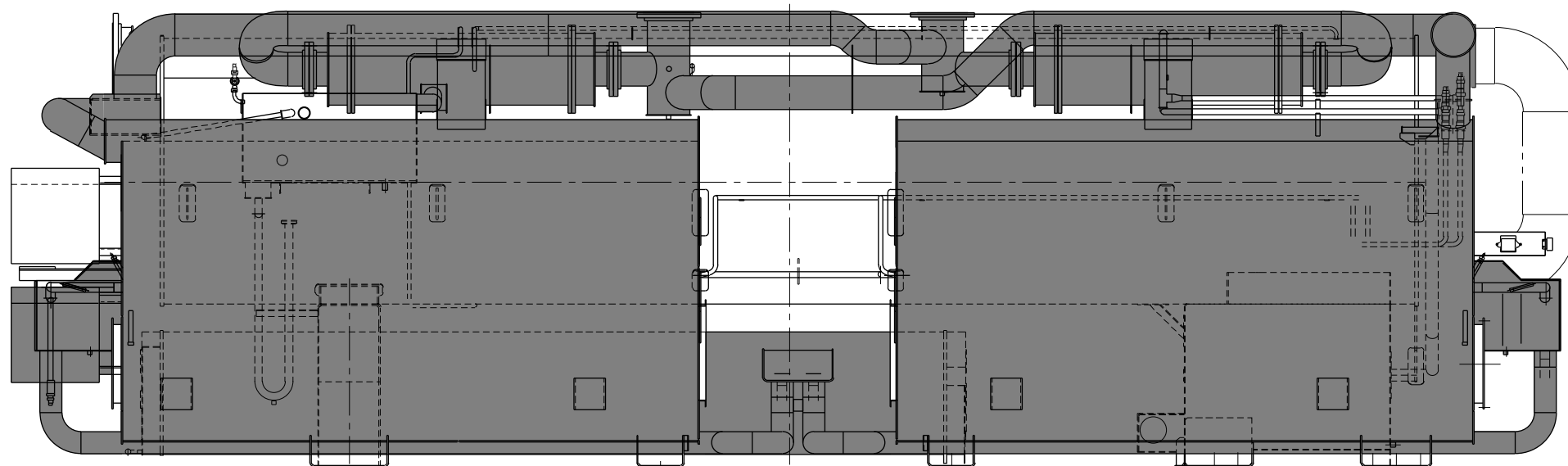

To mount insulation materials, use bonding agents, iron wires and bands. These methods do not penetrate the chiller system and jeopardize the integrity of the vacuum pressure in the chiller. **Weld pins are not acceptable.**

Proper Insulation Practices

1. Insulation on pumps, valves, sight glasses equipment and flange sections should be mounted so that it can be removed easily.
2. Water boxes or cover plates must be removed/opened from time to time for tube cleaning. Valves, pumps and nozzles must be accessible for servicing and operation.
3. Insulate auxiliary and instrument piping by wrapping glass wool around it.

LEGEND

	Hot
	Intermediate
	Cold

Insulation Methods to Avoid

1. Do not insulate moving parts such as valve handles.
2. Do not insulate thermowells.
3. Do not cover sight glasses with insulation.
4. Do not cover pipe connections, since they must be accessible for pressure and vacuum tests.
5. Do not cover pump motors with insulation.
6. Do not use weld pins to attach insulation.

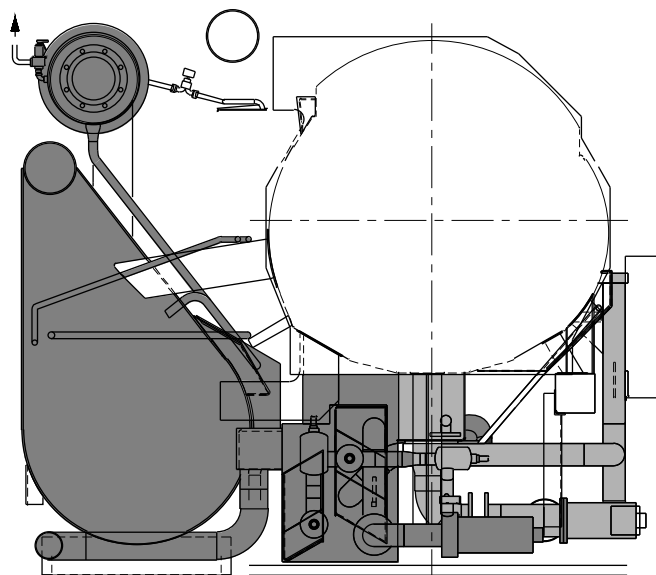
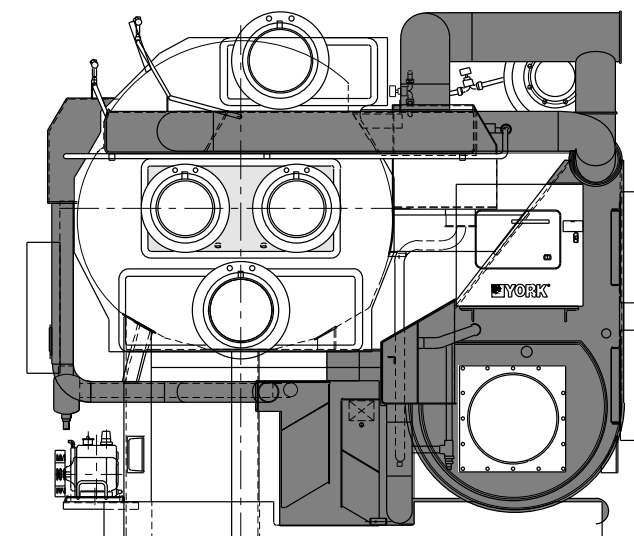
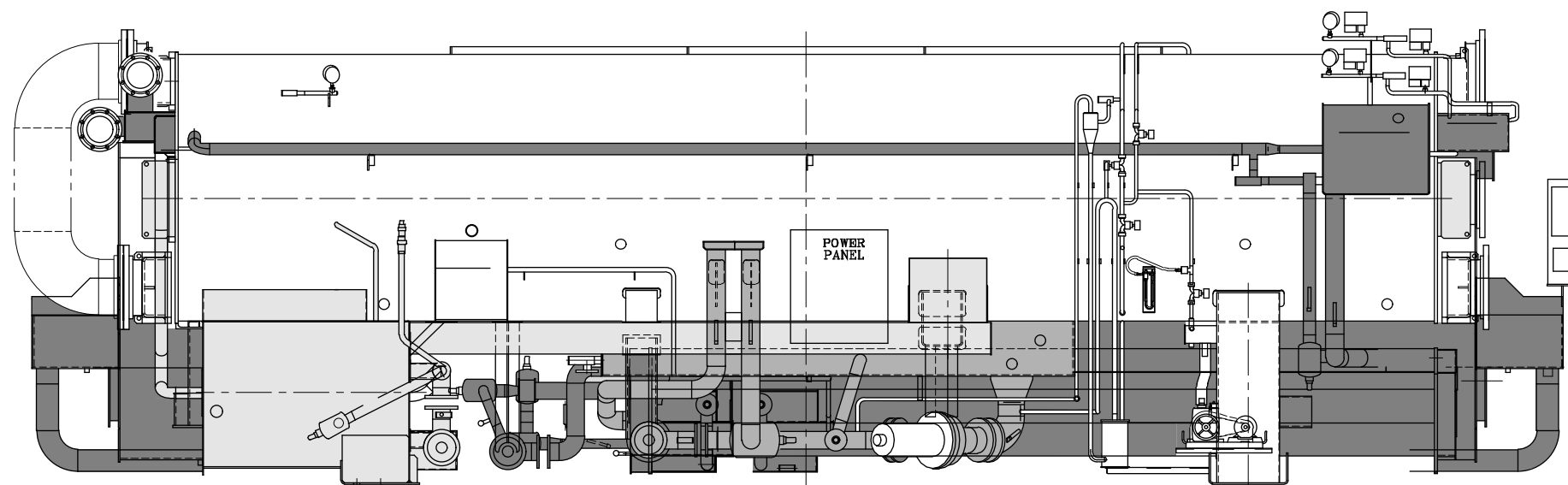

To mount insulation materials, use bonding agents, iron wires and bands. These methods do not penetrate the chiller system and jeopardize the integrity of the vacuum pressure in the chiller. **Weld pins are not acceptable.**

Proper Insulation Practices

1. Insulation on pumps, valves, sight glasses equipment and flange sections should be mounted so that it can be removed easily.
2. Water boxes or cover plates must be removed/opened from time to time for tube cleaning. Valves, pumps and nozzles must be accessible for servicing and operation.
3. Insulate auxiliary and instrument piping by wrapping glass wool around it.

LEGEND

	Hot
	Intermediate
	Cold

Insulation Methods to Avoid

1. Do not insulate moving parts such as valve handles.
2. Do not insulate thermowells.
3. Do not cover sight glasses with insulation.
4. Do not cover pipe connections, since they must be accessible for pressure and vacuum tests.
5. Do not cover pump motors with insulation.
6. Do not use weld pins to attach insulation.

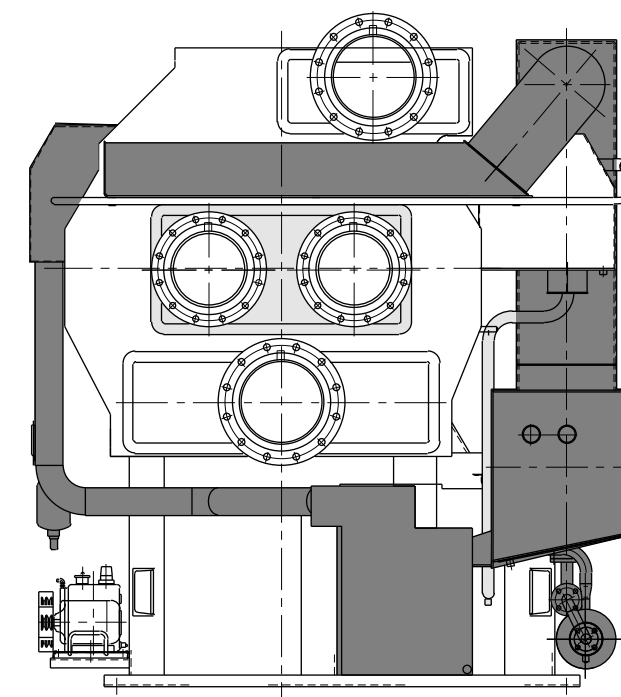
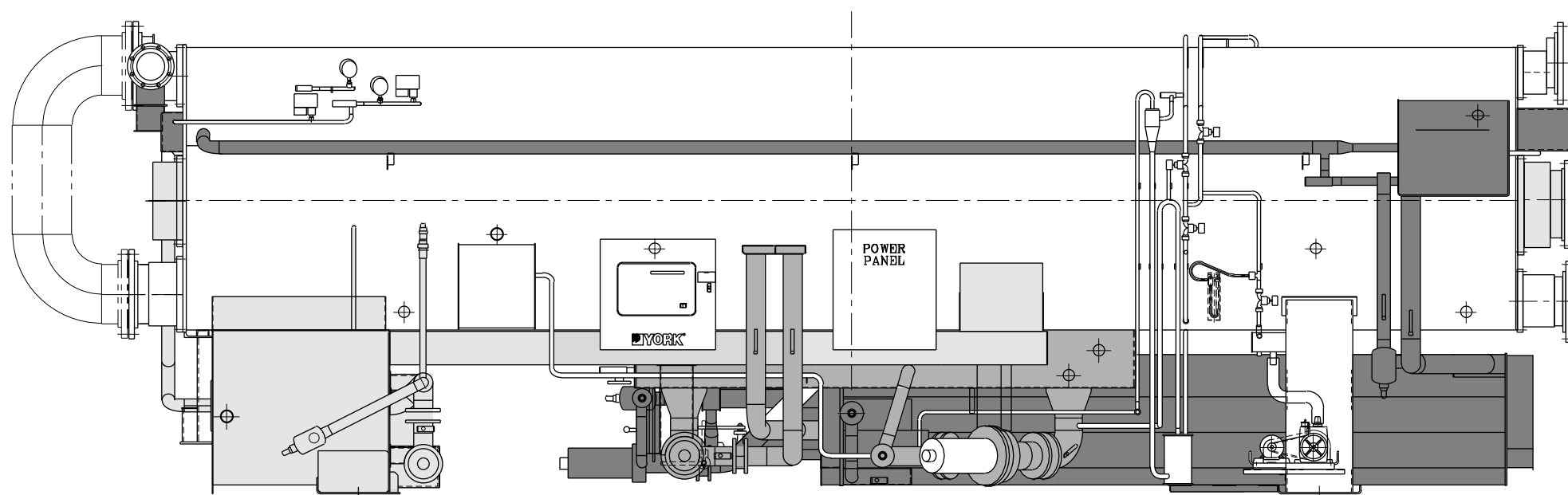

To mount insulation materials, use bonding agents, iron wires and bands. These methods do not penetrate the chiller system and jeopardize the integrity of the vacuum pressure in the chiller. **Weld pins are not acceptable.**

Proper Insulation Practices

1. Insulation on pumps, valves, sight glasses equipment and flange sections should be mounted so that it can be removed easily.
2. Water boxes or cover plates must be removed/opened from time to time for tube cleaning. Valves, pumps and nozzles must be accessible for servicing and operation.
3. Insulate auxiliary and instrument piping by wrapping glass wool around it.

LEGEND

	Hot
	Intermediate
	Cold

Insulation Methods to Avoid

1. Do not insulate moving parts such as valve handles.
2. Do not insulate thermowells.
3. Do not cover sight glasses with insulation.
4. Do not cover pipe connections, since they must be accessible for pressure and vacuum tests.
5. Do not cover pump motors with insulation.
6. Do not use weld pins to attach insulation.

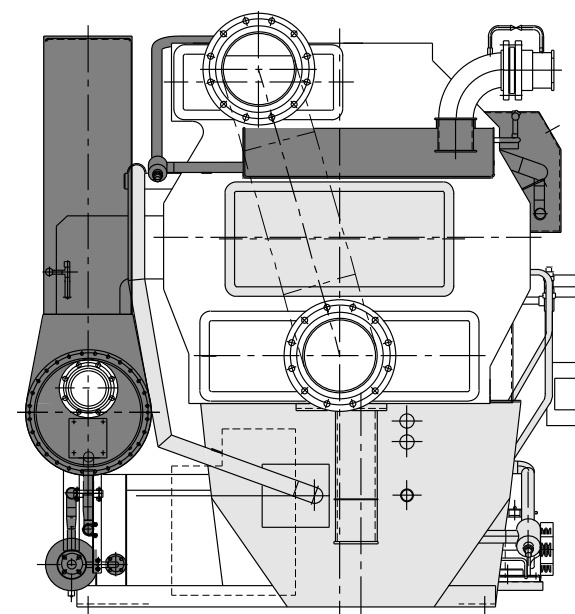
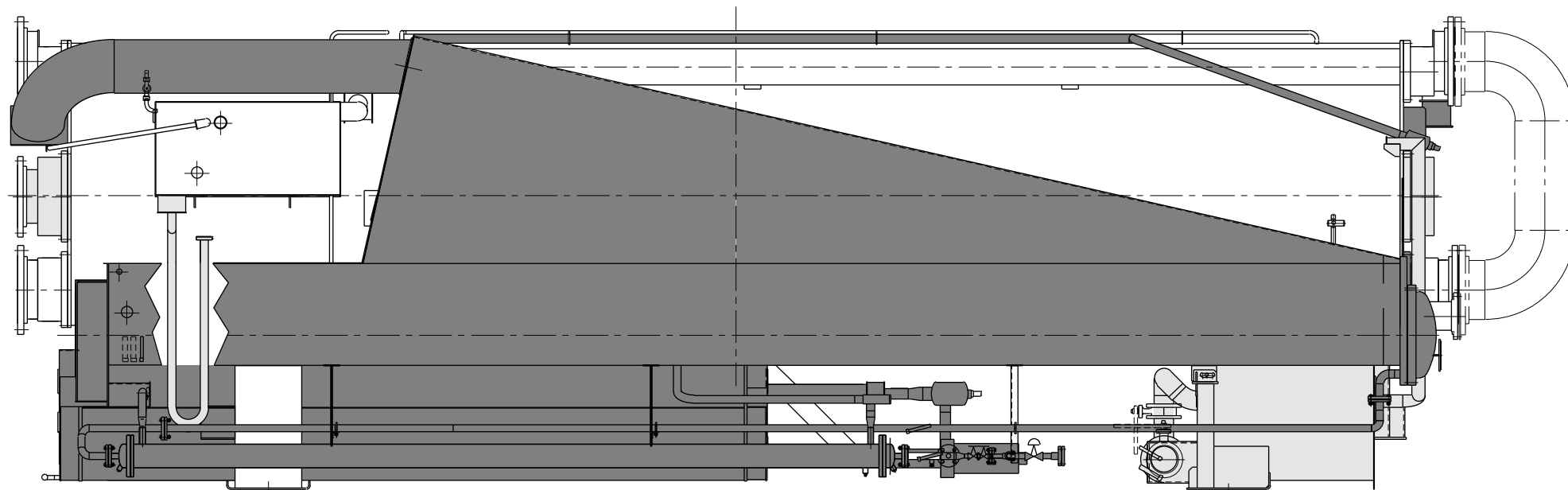

To mount insulation materials, use bonding agents, iron wires and bands. These methods do not penetrate the chiller system and jeopardize the integrity of the vacuum pressure in the chiller. **Weld pins are not acceptable.**

Proper Insulation Practices

1. Insulation on pumps, valves, sight glasses equipment and flange sections should be mounted so that it can be removed easily.
2. Water boxes or cover plates must be removed/opened from time to time for tube cleaning. Valves, pumps and nozzles must be accessible for servicing and operation.
3. Insulate auxiliary and instrument piping by wrapping glass wool around it.

LEGEND

	Hot
	Intermediate
	Cold

Insulation Methods to Avoid

1. Do not insulate moving parts such as valve handles.
2. Do not insulate thermowells.
3. Do not cover sight glasses with insulation.
4. Do not cover pipe connections, since they must be accessible for pressure and vacuum tests.
5. Do not cover pump motors with insulation.
6. Do not use weld pins to attach insulation.

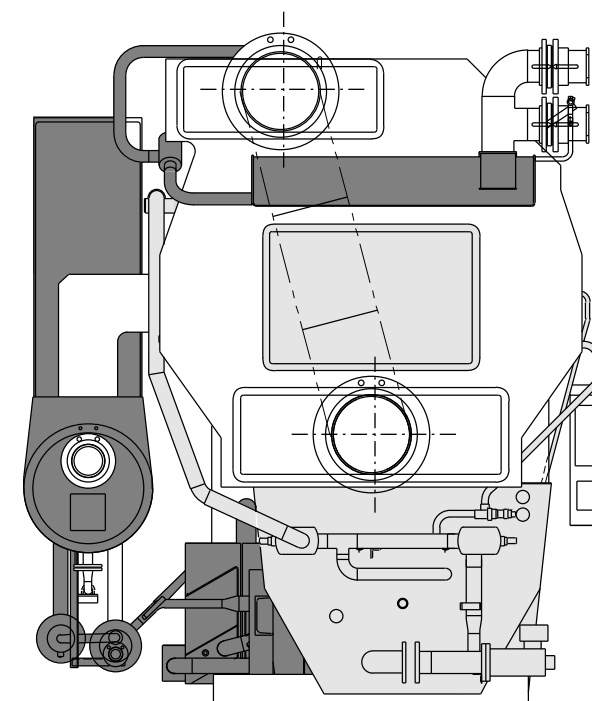
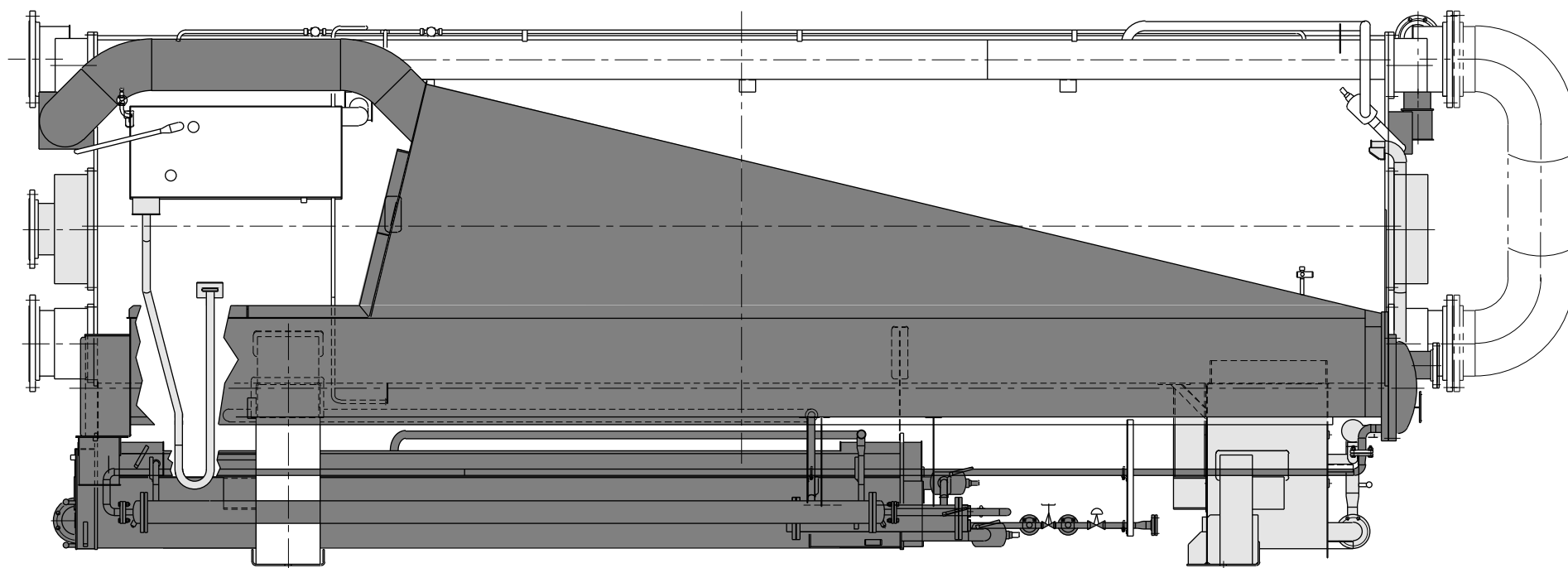

To mount insulation materials, use bonding agents, iron wires and bands. These methods do not penetrate the chiller system and jeopardize the integrity of the vacuum pressure in the chiller. **Weld pins are not acceptable.**

Proper Insulation Practices

1. Insulation on pumps, valves, sight glasses equipment and flange sections should be mounted so that it can be removed easily.
2. Water boxes or cover plates must be removed/opened from time to time for tube cleaning. Valves, pumps and nozzles must be accessible for servicing and operation.
3. Insulate auxiliary and instrument piping by wrapping glass wool around it.

LEGEND

	Hot
	Intermediate
	Cold

Insulation Methods to Avoid

1. Do not insulate moving parts such as valve handles.
2. Do not insulate thermowells.
3. Do not cover sight glasses with insulation.
4. Do not cover pipe connections, since they must be accessible for pressure and vacuum tests.
5. Do not cover pump motors with insulation.
6. Do not use weld pins to attach insulation.

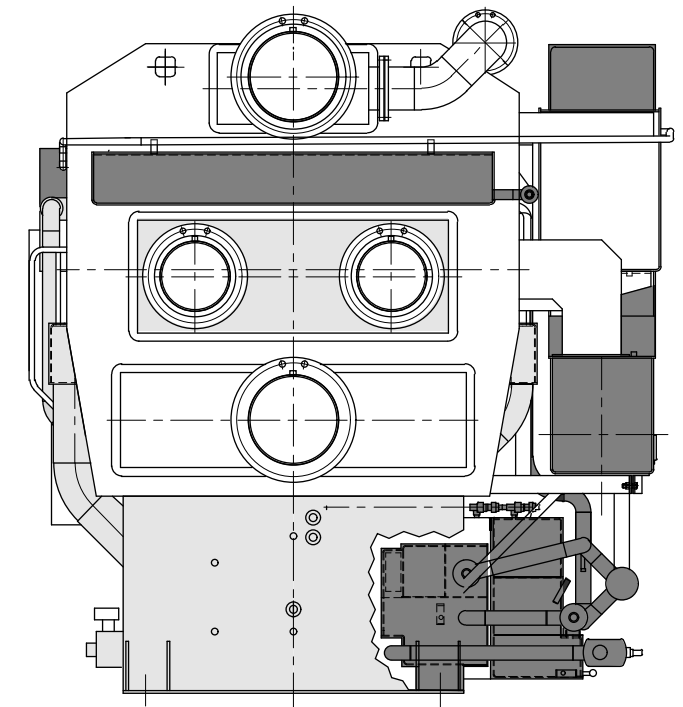
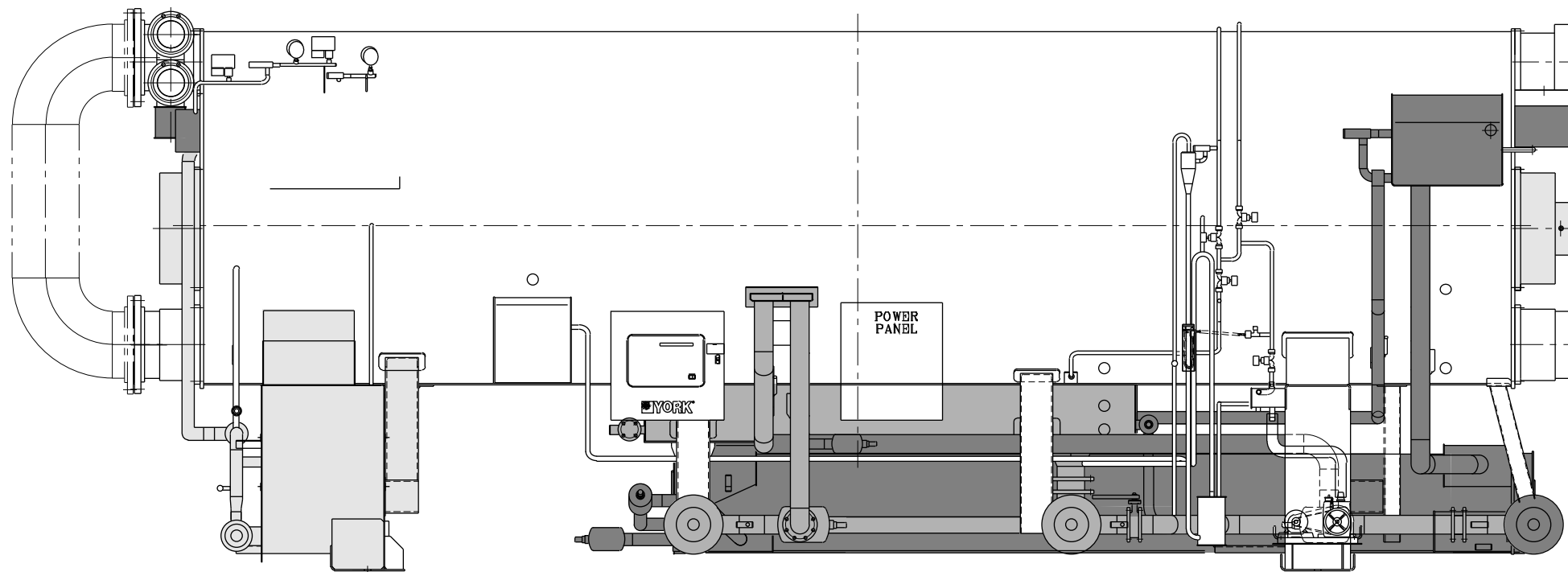

To mount insulation materials, use bonding agents, iron wires and bands. These methods do not penetrate the chiller system and jeopardize the integrity of the vacuum pressure in the chiller. **Weld pins are not acceptable.**

Proper Insulation Practices

1. Insulation on pumps, valves, sight glasses equipment and flange sections should be mounted so that it can be removed easily.
2. Water boxes or cover plates must be removed/opened from time to time for tube cleaning. Valves, pumps and nozzles must be accessible for servicing and operation.
3. Insulate auxiliary and instrument piping by wrapping glass wool around it.

LEGEND

	Hot
	Intermediate
	Cold

Insulation Methods to Avoid

1. Do not insulate moving parts such as valve handles.
2. Do not insulate thermowells.
3. Do not cover sight glasses with insulation.
4. Do not cover pipe connections, since they must be accessible for pressure and vacuum tests.
5. Do not cover pump motors with insulation.
6. Do not use weld pins to attach insulation.

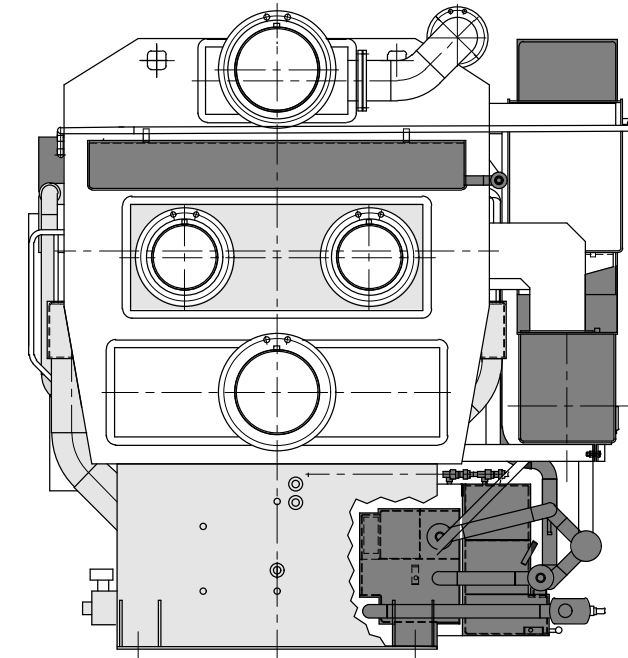
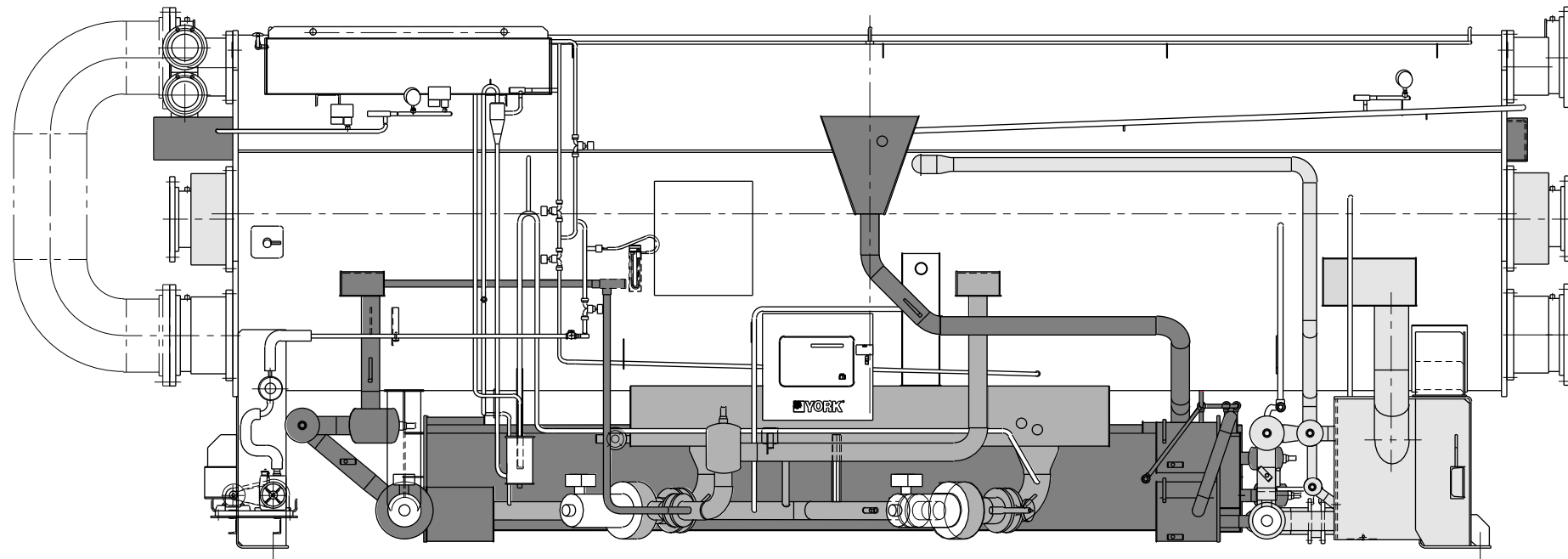

To mount insulation materials, use bonding agents, iron wires and bands. These methods do not penetrate the chiller system and jeopardize the integrity of the vacuum pressure in the chiller. **Weld pins are not acceptable.**

Proper Insulation Practices

1. Insulation on pumps, valves, sight glasses equipment and flange sections should be mounted so that it can be removed easily.
2. Water boxes or cover plates must be removed/opened from time to time for tube cleaning. Valves, pumps and nozzles must be accessible for servicing and operation.
3. Insulate auxiliary and instrument piping by wrapping glass wool around it.

LEGEND

	Hot
	Intermediate
	Cold

Insulation Methods to Avoid

1. Do not insulate moving parts such as valve handles.
2. Do not insulate thermowells.
3. Do not cover sight glasses with insulation.
4. Do not cover pipe connections, since they must be accessible for pressure and vacuum tests.
5. Do not cover pump motors with insulation.
6. Do not use weld pins to attach insulation.

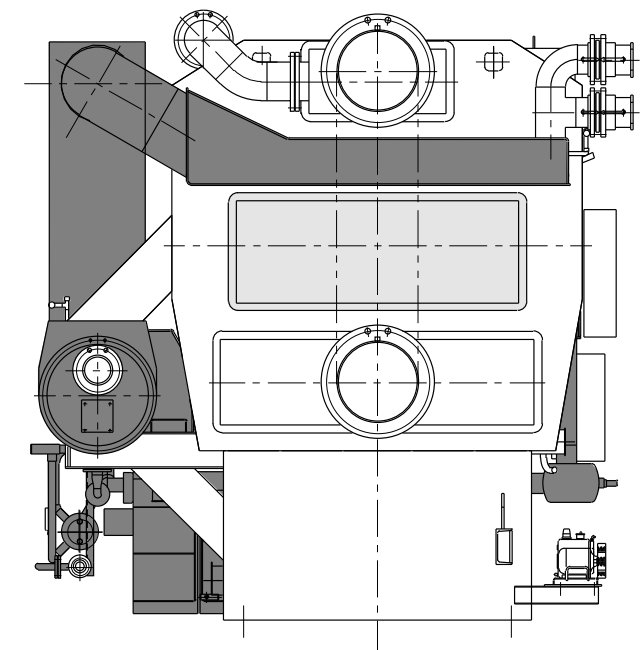
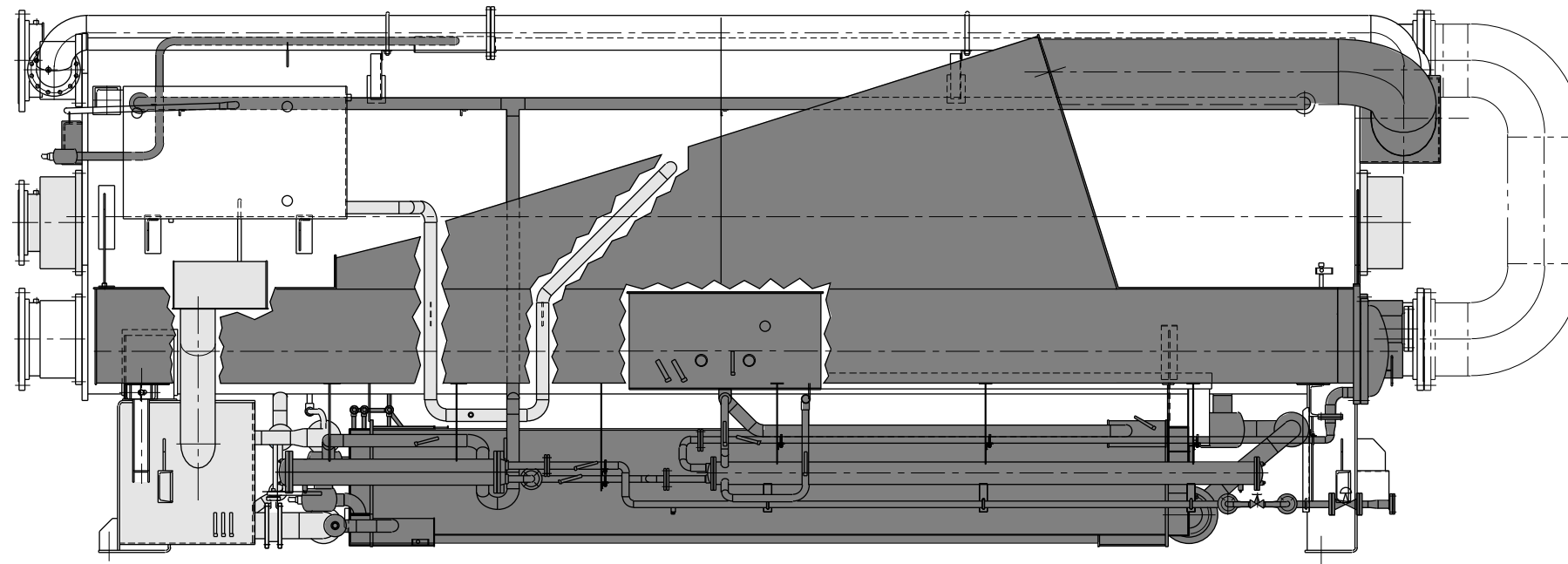



To mount insulation materials, use bonding agents, iron wires and bands. These methods do not penetrate the chiller system and jeopardize the integrity of the vacuum pressure in the chiller. **Weld pins are not acceptable.**

Proper Insulation Practices

1. Insulation on pumps, valves, sight glasses equipment and flange sections should be mounted so that it can be removed easily.
2. Water boxes or cover plates must be removed/opened from time to time for tube cleaning. Valves, pumps and nozzles must be accessible for servicing and operation.
3. Insulate auxiliary and instrument piping by wrapping glass wool around it.

LEGEND

	Hot
	Intermediate
	Cold

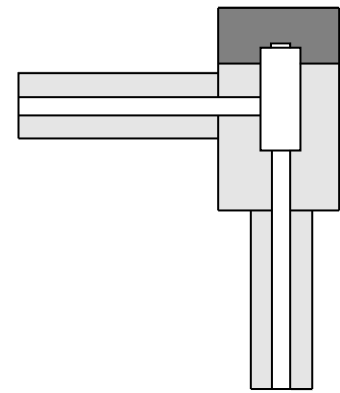

Spindle Valve
(Flow Setting)

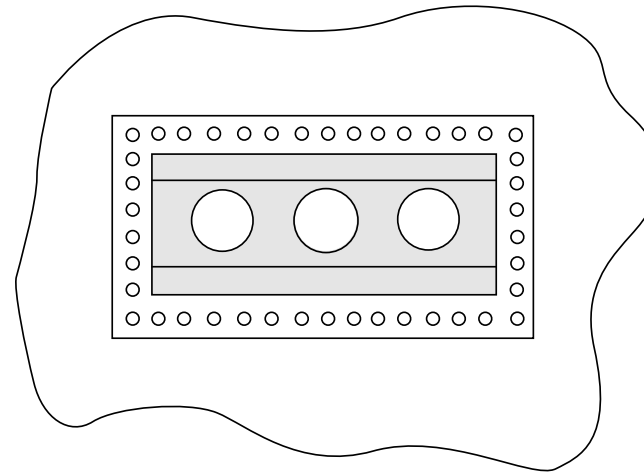

Water Box With Adjoining Piping

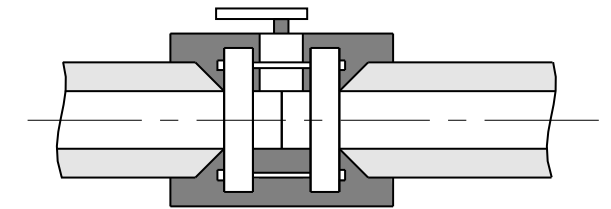
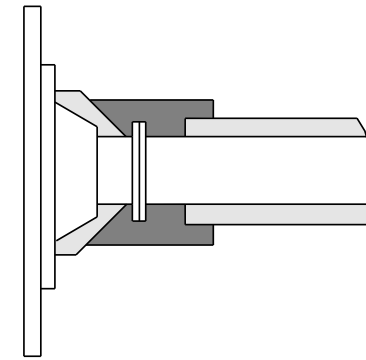

Butterfly Valve

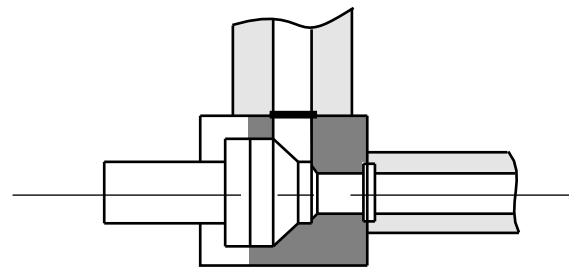

Pump

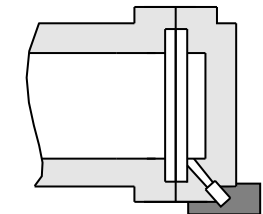

Drain

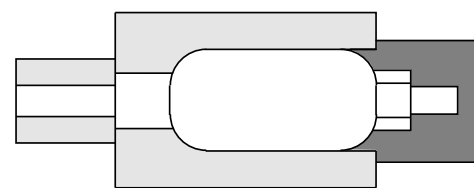

Globe Valve

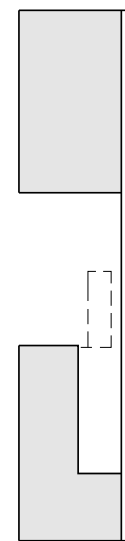

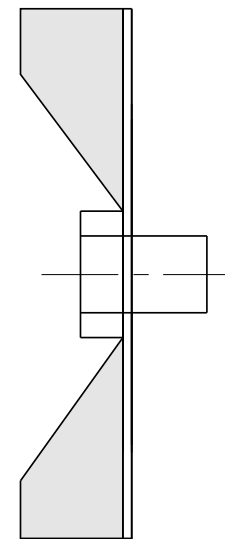

Thermowell

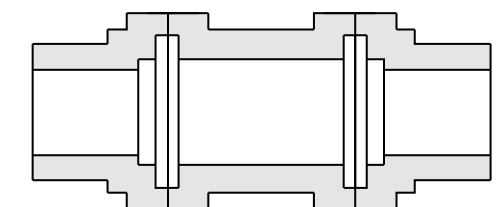

Sightglass



LEGEND

-  Hot
-  Intermediate
-  Cold