



BY JOHNSON CONTROLS

**SINGLE STAGE YIA
ABSORPTION CHILLERS
WITH OPTIVIEW™ CONTROL CENTER**

OPERATION MANUAL

New Release

Form 155.21-O1 (410)

**YIA MOD D
SINGLE STAGE
STEAM / HOT WATER
WITH OPTIVIEW™ CONTROL CENTER**



1A1 through 14F3

LD13714

IMPORTANT!

READ BEFORE PROCEEDING!

GENERAL SAFETY GUIDELINES

This equipment is a relatively complicated apparatus. During installation, operation, maintenance or service, individuals may be exposed to certain components or conditions including, but not limited to: refrigerants, oils, materials under pressure, rotating components, and both high and low voltage. Each of these items has the potential, if misused or handled improperly, to cause bodily injury or death. It is the obligation and responsibility of operating/service personnel to identify and recognize these inherent hazards, protect themselves, and proceed safely in completing their tasks. Failure to comply with any of these requirements could result in serious damage to the equipment and the property in which it is situated, as well as severe personal injury or death to themselves and people at the site.

This document is intended for use by owner-authorized operating/service personnel. It is expected that this individual possesses independent training that will enable them to perform their assigned tasks properly and safely. It is essential that, prior to performing any task on this equipment, this individual shall have read and understood this document and any referenced materials. This individual shall also be familiar with and comply with all applicable governmental standards and regulations pertaining to the task in question.

SAFETY SYMBOLS

The following symbols are used in this document to alert the reader to areas of potential hazard:



DANGER indicates an imminently hazardous situation which, if not avoided, will result in death or serious injury.

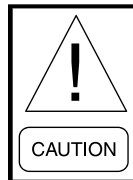

CAUTION identifies a hazard which could lead to damage to the machine, damage to other equipment and/or environmental pollution. Usually an instruction will be given, together with a brief explanation.



WARNING indicates a potentially hazardous situation which, if not avoided, could result in death or serious injury.

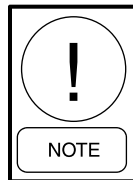

NOTE is used to highlight additional information which may be helpful to you.



External wiring, unless specified as an optional connection in the manufacturer's product line, is NOT to be connected inside the micro panel cabinet. Devices such as relays, switches, transducers and controls may NOT be installed inside the micro panel. NO external wiring is allowed to be run through the micro panel. All wiring must be in accordance with YORK's published specifications and must be performed ONLY by qualified Johnson Controls personnel. Johnson Controls will not be responsible for damages/problems resulting from improper connections to the controls or application of improper control signals. Failure to follow this will void the manufacturer's warranty and cause serious damage to property or injury to persons.

CHANGEABILITY OF THIS DOCUMENT

In complying with YORK/Johnson Controls policy for continuous product improvement, the information contained in this document is subject to change without notice. While Johnson Controls makes no commitment to update or provide current information automatically to the manual owner, that information, if applicable, can be obtained by contacting the nearest YORK/Johnson Controls Service Office.

It is the responsibility of operating/service personnel as to the applicability of these documents to the equipment in question. If there is any question in the mind of operating/service personnel as to the applicability of these documents, then, prior to working on the equipment, they should verify with the owner whether the equipment has been modified and if current literature is available.

ASSOCIATED LITERATURE

DESCRIPTION	FORM NO.
OPERATION – YIA UNIT	155.21-OM1
SERVICE – YIA UNIT	155.21-M2
INSTALLATION – YIA UNIT	155.21-N1
SERVICE – YIA OPTIVIEW CONTROL CENTER	155.21-M1
RENEWAL PARTS – YIA OPTIVIEW CONTROL CENTER	155.21-RP1
RENEWAL PARTS – YIA UNIT	155.21-RP2
WIRING DIAGRAM – YIA UNIT	155.21-W1
WIRING DIAGRAM – YIA FIELD CONTROL MODIFICATIONS	155.21-W2
WIRING DIAGRAM – YIA FIELD CONNECTIONS	155.21-W3

NOMENCLATURE

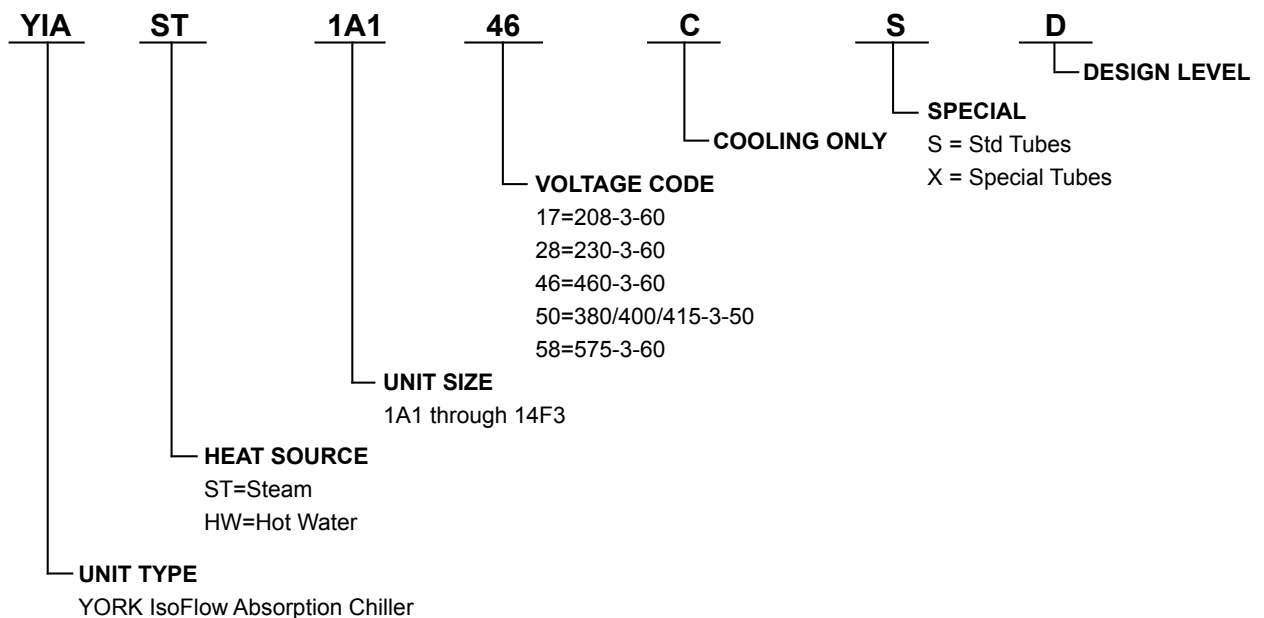

TABLE OF CONTENTS

SECTION 1	DESCRIPTION OF SYSTEM AND FUNDAMENTALS OF OPERATION ..	5
SECTION 2	OPTIVIEW CONTROL CENTER	11
	Setpoints and Configuration	12
	Unit Operation	12
	Unit Operation Under Power Failure Condition	19
	OptiView Control Center	20
	Interface Conventions	21
	Navigation	22
	Languages	22
	Analog Input Ranges	24
	Home Screen	26
	Evaporator / Absorber Screen	28
	Generator / Condenser Screen	30
	System Screen	32
	Purge Screen	34
	Purge Trend Screen	36
	Control Valve Screen	37
	Setpoints Screen	38
	Diagnostics Screen	42
	Sales Order Screen	43
	History Screen	44
	Trend Screen	45
	Trend Setup Screen	48
	Triggers Screen	49
	Display Messages	51
	Status Messages	51
	Run Messages	51
	Start Inhibit Messages	53
	Warning Messages	53
	Routine Shutdown Messages	57
	Cycling Shutdown Messages	57
	Safety Shutdown Messages	58
	Equipment Status Messages	63
SECTION 3	PRINTERS	65
	Printer Setup	66
	Control Center Setup	67
	Downloading Histories to a Laptop	71

LIST OF FIGURES

FIGURE 1 – MODEL YIA OPTIVIEW CHILLER	5	FIGURE 14 – SALES ORDER SCREEN	43
FIGURE 2 – FLOW DIAGRAM	9	FIGURE 15 – HISTORY SCREEN	44
FIGURE 3 – OPTIVIEW CONTROL CENTER	20	FIGURE 16 – TREND SCREEN	46
FIGURE 4 – YIA OPTIVIEW NAVIGATION	23	FIGURE 17 – TREND SETUP SCREEN	48
FIGURE 5 – HOME SCREEN	26	FIGURE 18 – TRIGGERS SCREEN	49
FIGURE 6 – EVAPORATOR / ABSORBER SCREEN	28	FIGURE 19 - PRINTERS	65
FIGURE 7 – GENERATOR / CONDENSER SCREEN	30	FIGURE 20 – SAMPLE PRINTOUT (OPERATING DATA)	67
FIGURE 8 – SYSTEM SCREEN	32	FIGURE 21 – SAMPLE PRINTOUT (LAST NORMAL STOP) ..	68
FIGURE 9 – PURGE SYSTEM SCREEN	34	FIGURE 22 – SAMPLE PRINTOUT (SALES ORDER)	68
FIGURE 10 – PURGE TREND SCREEN	36	FIGURE 23 – SAMPLE PRINTOUT (HISTORY)	69
FIGURE 11 – CONTROL VALVE SCREEN	37	FIGURE 24 – SAMPLE PRINTOUT (PURGE TREND)	69
FIGURE 12 – SETPOINTS SCREEN	38	FIGURE 25 – SAMPLE PRINTOUT (SETPOINTS)	67
FIGURE 13 – DIAGNOSTICS SCREEN	42	FIGURE 26 – COMMUNICATIONS BLOCK DIAGRAM	71

SECTION 1

DESCRIPTION OF SYSTEM AND FUNDAMENTALS OF OPERATION



FIGURE 1 – MODEL YIA ABSORPTION CHILLER

LD14498

GENERAL INFORMATION

The chiller is controlled by a modern state of the art Microcomputer Control Center that monitors its operation. The Control Center is programmed by the operator to suit job specifications. The operating status, temperatures, pressures, and other information pertinent to operation of the chiller are automatically displayed and read on a graphic display. Other display screens can be observed by pressing the keys as labelled on the control center.

The principle of refrigeration is the exchange of heat and, in absorption liquid chilling, there are four basic heat exchange surfaces: the evaporator, the absorber, the generator and the condenser.

In absorption chilling, the refrigerant is water but, like any refrigeration system, absorption chilling uses evaporation and condensation to remove heat. To maintain effective evaporation and condensation, absorption chilling employs two shells which operate at different controlled vacuums.

The lower shell (Evaporator and Absorber) has an internal absolute pressure of about one one-hundredth that of the outside atmosphere - or six millimeters of mercury, a relatively high vacuum. The vacuum allows

water (the refrigerant) to boil at a temperature below that of the liquid being chilled. Chilled liquid entering the evaporator can be cooled for air conditioning or process cooling applications.

Evaporator

The section of a chiller that is responsible for removing the heat from the chilled water circuit, thus cooling the chilled water to be used to cool a building, a manufacturing process, or whatever application it is intended. Typically, the chilled water is cooled from 54°F - 44°F (12.2 - 6.6°C).

In an absorption chiller, the pure refrigerant generated in the generator is cooled and condensed in the Condenser and supplied to the Evaporator. Here, it is immediately exposed to a much lower pressure which causes some immediate flashing (boiling). Most of the refrigerant cools to the saturation temperature and remains in liquid form. It is then pumped and sprayed over the Evaporator tube bundle. As the refrigerant passes over the outer surface of the tubes, it evaporates (i.e. flashes or boils) because of the low pressure, approximately 5.5-6.5 mmHg which is equivalent to a saturation temperature of 36-41°F (2.2-5°C). The refrigerant vapor is then immediately drawn through the eliminator towards the Absorber. This vacuum is caused by the hygroscopic action, the affinity Lithium Bromide has for the refrigerant vapor.

Absorber

The concentrated solution coming back from the generator is partially mixed with solution from the absorber section then pumped to a solution spray header where it is sprayed over the tubes in the absorber. Refrigerant vapor is absorbed into the solution and the solution is thus diluted. This diluted solution is collected at the bottom of the absorber where it is again pumped to the generator.

Generator

The diluted solution is then pumped through the heat exchanger, where it is preheated by hot concentrated solution from the generator. The heat exchanger improves the efficiency of the cycle by reducing the amount of steam or hot water required to heat the dilute solution in the generator. The dilute solution then continues to the upper shell containing the Generator and Condenser, where the absolute pressure is approximately one-tenth that of the outside atmosphere, or seventy millimeters of mercury. The dilute solution flows over the generator tubes and is heated by steam or hot water passing through the interior of the tubes. The amount of heat input from the steam or hot water is controlled by a motorized valve and is in response to the required cooling load. The hot generator tubes boil the dilute solution, releasing refrigerant vapor.

Condenser

The refrigerant vapor rises to the condenser and is condensed by the cooler tower water running through the condenser tubes. The liquid refrigerant flows back to the lower shell, and is once again sprayed over the evaporator. The refrigerant cycle has been completed. Now the concentrated lithium bromide solution flows from the generator back to the absorber in the lower shell, ready to absorb more refrigerant. Its cycle has also been completed.

Solution Heat Exchanger

A counterflow Solution to Solution Heat Exchanger. A component that exchanges heat between two streams of Lithium Bromide solution. The hotter the solution being supplied to the generators is, the less heat that needs to be added, thus improving efficiency. Likewise, the cooler the solution is going to the Absorber, the less heat that needs to be removed by the cooling tower. Therefore, the heat exchanger preheats the solution going to the generator and cools the solution going to the Absorber.

Solution Pump

A hermetically sealed, centrifugal pump located under the absorber. It receives diluted lithium bromide solution from the absorber shell and circulates it through a heat exchanger, then up to the generator. The discharge of this pump operates in a pressure that is above atmospheric pressure. The pump is cooled by the solution it is pumping.

Refrigerant Pump

A hermetically sealed, centrifugal pump located downstream of the evaporator outlet box. This pump receives liquid refrigerant from the evaporator and discharges it back up to the evaporator sprays. It continues to re-circulate the refrigerant while the chiller is operational.

Purge Pump

An external pump connected to the purge system of the unit. This pump is used to evacuate non-condensables from the unit.

Eductor

An eductor is a liquid-powered jet pump. Jet pumps have no moving parts and use a high-pressure stream of liquid to pass through a nozzle, causing a portion of a low-pressure stream coming into the side of the pump to combine with the nozzle stream. This causes a reduction in pressure at the low-pressure inlet and induces the rest of the low-pressure inlet substance to flow into the body of the pump.

On IsoFlow™ units, an eductor is used in place of a centrifugal pump to induce strong concentrated solution exiting the generator outlet box to combine with weak concentrated solution exiting the solution pump discharge, before going to the absorber spray header.

Level Switches

There are two level switches that sense liquid levels on the IsoFlow units. Both are located in the refrigerant circuit. Switch (1F) is at the side of the evaporator refrigerant outlet box, and senses the level in the box. At low levels in this box, the 1F switch will open, causing the control panel to initiate corrective procedures to keep the unit from running out of refrigerant. Switch (3F) is located just before the inlet of the Buffalo refrigerant pump. It's main purpose is to keep the Buffalo pump from cavitation and eventual overheating.

Power Panel

The power panel serves as single-point wiring location for the unit's incoming power wiring. It houses all the unit pump contactors and overloads, as well as fuses and terminal lugs for ease of serviceability. A transformer is included to reduce the incoming unit voltage to the micropanel.

Isolation Valve

One isolation valve is located at each Buffalo Pump inlet and outlet. It is a positive sealing, butterfly type valve mounted between standard ANSI flanges. Each valve incorporates an EPDM liner on the valve face to act as a sealing surface. When closed, the valves will isolate the unit vacuum from the pump area to offer ease of serviceability when servicing the pumps.

Hot Water Valve

The capacity control valve which regulates the amount of hot water to the generator (Hot Water units only).

Steam Valve

The capacity control valve which regulates the amount of steam to the unit (Steam units only).

Oil Trap

The oil trap is located between the purge pump suction connection and the unit. It is designed so it will hold one complete oil charge of the vacuum pump. In the event air was to get into the unit through the vacuum pump, the low pressure in the absorber would induce the oil into the system. Therefore, the oil trap is used as a safety measure to protect the absorption unit from the oil.

Orifice

A restriction in a liquid line for the purpose of reducing the internal diameter of the line. Usually created by a blank piece of metal with a small hole drilled into it, to create a pressure differential when a liquid passes through it.

Pass Baffle

A division plate or plates (baffles) inserted into a water box to create chambers which force the water to pass through different portions of the tube bundle, called passes. Although the pressure drop increases with increasing passes, the trade-off for heat transfer optimization and nozzle locations are justified.

Rupture Disk

Although IsoFlow™ absorption units operate at less than atmospheric pressure (a vacuum), if certain safeties fail and/or incorrect valves are closed, the unit could experience higher pressures in certain chambers. Therefore, a pressure relief apparatus, a rupture disk, is added.

Automatic De-crystallization Pipe (ADC)

The automatic de-crystallization pipe is a U-shaped line coming off the generator solution outlet box and terminating in the absorber shell. During normal unit operation, this line has no flow in it. If crystallization were to occur, it would normally be in the strong solution side of the heat exchanger. This blockage would back up solution into the generator solution and into the automatic de-crystallization pipe. Once the hot solution goes into the ADC pipe, it bypasses the heat exchanger and goes directly into the absorber shell, thus heating the solution in the absorber shell. The heated solution in the absorber then heats up the crystallized heat exchanger from the opposite side of the tubes and causes the crystallized lithium bromide to dissolve back into solution.

ADC Flush Line

This line runs between the solution pump discharge and the ADC line. When the solution pump runs, weak solution is constantly supplied to the ADC line. This keeps the ADC line from crystallizing, due to it being exposed to the low pressures generated within the absorber while the unit is running.

Alcohol (2-Ethylhexanol)

A liquid added to an absorption chiller (about 1% by mass) to enhance the heat and mass transfer in the Absorber. It is an octyl alcohol whose chemical name is 2-Ethyl-1-Hexanol (C₈H₁₈O) with a molecular weight of 130.2, a boiling point of 364.3°F (184.6°C), and a flash point of 177.8°F (81°C) at 760 mmHg. Having a colorless, clear appearance, it has a somewhat pungent odor. By adding 2-Ethylhexanol to the absorption cycle, overall unit performance increases by 5-15%. In addition, cycle temperatures, pressures, and concentrations tend to decrease with the addition of 2-Ethylhexanol.

Concentration

The percent by weight of lithium bromide present in solution. New solution is sent with a concentration of 53%.

Condenser (Tower) Water

The external water loop which is used to remove heat from the unit. This water passes first through the Absorber, then the Condenser. Typical temperatures are entering the Absorber at 85°F (29.4°C), leaving the Absorber (entering the Condenser, i.e. crossover) at 92°F (33.3°C), and leaving the Condenser at 95°F (35°C). Some external means of removing this heat is necessary. Typically a cooling tower is used for this application.

Inhibitor

An inhibitor is an additive in the solution that helps promote the formation of a protective iron oxide film on the interior ferrous surfaces in the unit. This film is called Magnetite and can be seen as a black coating. It is this protective coating, not the actual inhibitor, which helps to reduce internal corrosion rates in the machine. All new solution that comes with the chiller has the recommended amount of inhibitor included in it.

Non-condensables

A gaseous substance that cannot be liquified or condensed at the pressure and temperature surrounding it. The presence of non-condensables in the unit can cause severe performance problems. Non-condensables appear in two forms in the unit:

1. Internally generated non-condensables are formed as a by-product of corrosion.
2. Air may be drawn into a unit via leaks.

Non-condensables that collect in the absorber section of the unit blanket the heat transfer tubes and raise the internal pressure, thus reducing the absorber's ability to capture the refrigerant vapor. Non-condensables that collect in the high side of the unit end up in the condenser section, where they blanket the condenser tubes, reducing the condenser's capacity. It should be noted that the only non-condensable that is not self-generated by the chemistry inside the unit is nitrogen. Air is over 70% nitrogen; an air leak is the only external source of nitrogen. All other non-condensables are generated by various chemical reactions that occur internally for many different reasons.

Refrigerant

(Water, H₂O). Deionized water is used as the refrigerant.

Solution

A mixture of deionized water with a certain % by weight of dissolved lithium bromide (LiBr). Corrosion inhibitors are also added to the solution to reduce the internal corrosion rates in the unit.

2SOL

(Stabilizer refrigerant solenoid valve)

This solenoid valve is located on a separate line that goes between the discharge of the refrigerant pump to the generator's (return) strong solution line. This solenoid valve works in conjunction with the ADC (Automatic Decrystallization Line) & Short Dilution Cycle. When RT2 senses an increase in temperature to 160°F (71.1°C) in the ADC line, the 2SOL will be energized for a certain period of time, this will allow the transfer of refrigerant from the refrigerant pump to the generator's drain line, thus diluting the solution to the shell side of the solution-to-the shell side of the solution-to-solution (STS) heat exchanger. This valve can be energized manually from the control panel. This function acts as a "blow down" feature to accelerate the clean up of contaminated refrigerant.

3SOL

(Unloader refrigerant level solenoid valve)

This solenoid valve is located on a separate line between the discharge of the solution pump and the evaporator refrigerant outlet box. Its control is via the 1F refrigerant level switch. When 1F opens, the 3 SOL is energized to allow the transfer of solution from the solution pump to the evaporator refrigerant outlet box. This helps the chiller stay on line at light loads with low condenser water temperatures and keeps the refrigerant pump from cavitation by providing a sufficient supply of refrigerant.

1F

(Refrigerant level switch)

This switch is located in a separate chamber on the side of the evaporator refrigerant outlet box. It senses if a level is present or not in this box. If the level of refrigerant is not present the control logic will act to satisfy the refrigerant pump needs and sustain unit operation.

3F

(Refrigerant pump level switch)

This switch is located just before the refrigerant pump suction connection. It is used in conjunction with 1F refrigerant level switch to ensure a steady supply of refrigerant to the pump. When the refrigerant level decreases below the 3F switch, the logic control will start the count down on the preset refrigerant pump shutdown delay time. If the 3F switch closes before the shutdown delay time elapses, the count down is stopped and the refrigerant pump continues to operate.

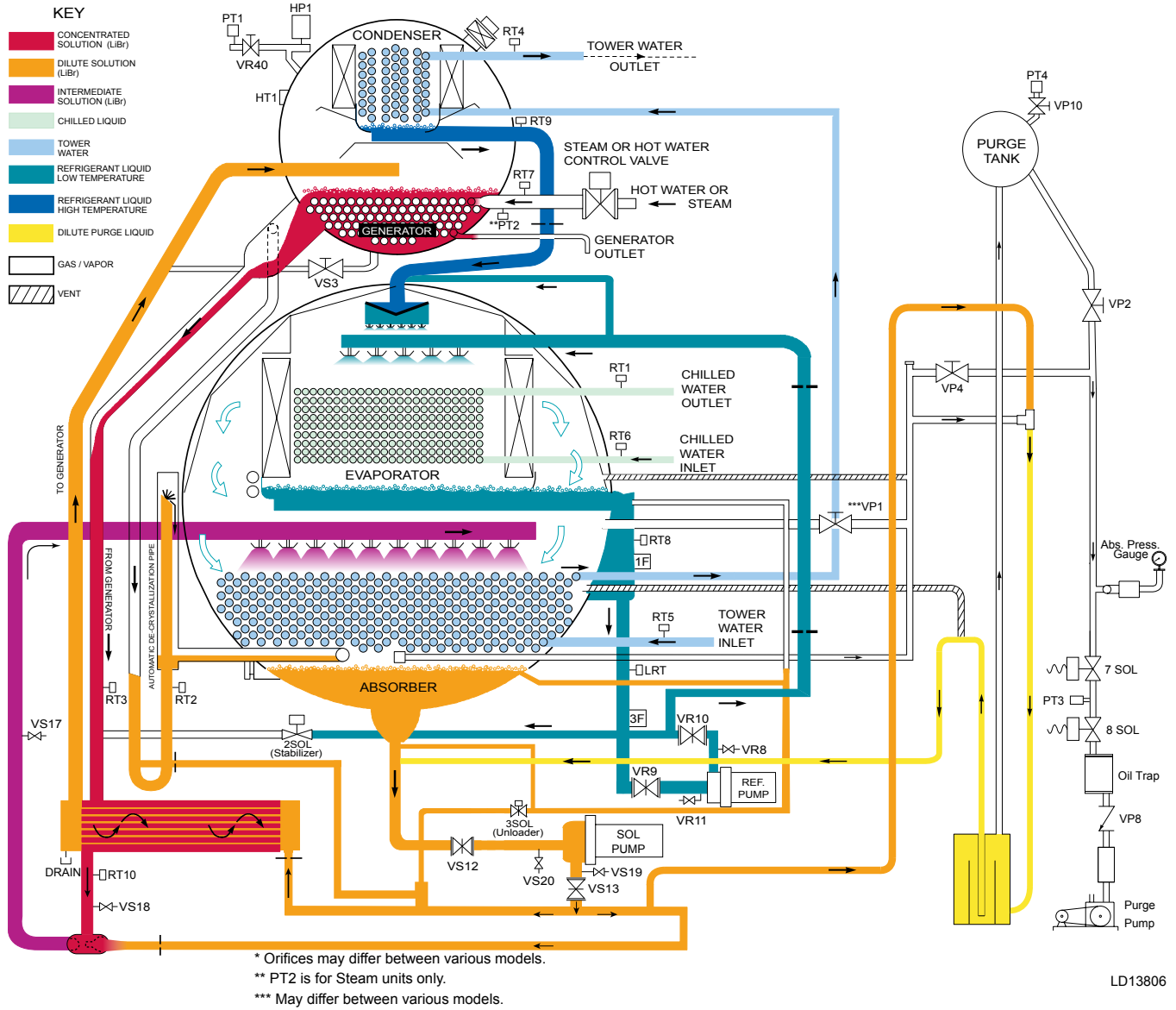

FIGURE 2 – FLOW DIAGRAM

THIS PAGE INTENTIONALLY LEFT BLANK

SECTION 2

OPTIVIEW CONTROL CENTER

INTRODUCTION

The YORK OptiView™ Control Center is a microprocessor based control system for YORK chillers.

The panel comes configured with a full screen LCD Graphic Display mounted in the middle of a keypad interface. The graphic display allows the presentation of several operating parameters at once. In addition, the operator may view a graphical representation of the historical operation of the chiller as well as the present operation. For the novice user, the locations of various chiller parameters are clearly and intuitively marked. Instructions for specific operations are provided on many of the screens.

The graphic display also allows information to be represented in both English (temperatures in °F and pressures in PSIG) and Metric (temperatures in °C and pressures in kPa) mode. The advantages are most apparent in the ability to display English, German, Italian, Spanish, and Portuguese languages.

The Control Center continually monitors the system operation and records the cause of any shutdowns (Safety, Cycling or Normal). This information is recorded in memory and is preserved even through a power failure condition. The user may recall it for viewing at any time by accessing the History Screen. During operation, the user is continually advised of the operating conditions by various status and warning messages. In addition, it may be configured to notify the user of certain conditions via alarms. A complete listing of shutdown, status, and warning messages is attached in the Display Messages section of this book.

There are certain screens, displayed values, programmable Setpoints and manual control shown in this book that are for Service Technician use only. They are only displayed when logged in at **SERVICE** access level or higher.

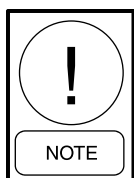

These parameters affect chiller operation and should NEVER be modified by anyone other than a qualified Service Technician.

The OptiView™ control center expands the capabilities of remote control and communications. By providing a common networking protocol through E-Link Gateway, YORK Chillers not only work well individually, but also as a team.

The E-Link Gateway provides communications for YORK chillers with Building Automation Systems (BAS). The E-link is a circuit board that can be installed directly in the OptiView Panel or can be supplied already mounted in a line voltage capable enclosure.

This new protocol allows increased remote control of the chiller, as well as 24-hour performance monitoring via a remote site. In addition, compatibility is maintained with the present network of E-Link communications. The chiller also maintains the standard digital remote capabilities as well. Both of these remote control capabilities allow for the standard Energy Management System (EMS) interface:

1. Remote Start
2. Remote Stop
3. Remote Leaving Chilled Liquid Temperature Setpoint adjustment (0-10VDC) or Pulse Width Modulation
4. Remote Load Limit Setpoint adjustment (0-10VDC) or Pulse Width Modulation
5. Remote “Ready to Start” Contacts
6. Safety Shutdown Contacts
7. Cycling Shutdown Contacts
8. *See 155.21-W2* for additional connection details

The chiller operating program resides in the OptiView control center Microboard. The control center could be equipped with the following Microboard:

- 031-02430-005 – The program resides in non-removable onboard memory. The software version is C.OPT.15.xx.yzz, and is viewable on the DIAGNOSTICS Screen in SERVICE access level. The program can be upgraded by downloading a new program from a Program Card. Program Cards are shirt-pocket-size portable memory storage devices available from YORK.

Software versions (C.OPT.15.xx.yzz) are alpha-numeric codes that represent the application, language package and revision levels per below. Each time the controls portion or language section is revised, the respective revision level increments.

- C – Commercial chiller
- OPT - Used on Microboard 031-02430-000
- 15 – YIA Absorption Chiller
- xx - controls revision level (00, 01, etc)
- y – language package (0=English only, 1=NEMA, 2=CE, 3=NEMA/CE)
- zz – language package revision level (00, 01, etc)

SETPOINTS AND CONFIGURATION OPTIONS

The operating setpoints and configurations can be accessed thru the OptiView control panel. Modifications to the setpoints and configurations can only be done from the OPERATOR or SERVICE level.

UNIT OPERATION

Start and Stop the Unit

The unit can be started using the main switch, using a remote signal when the unit is in remote mode or by a scheduled starting.

If the steam or hot water control valve is open less than 10% and the leaving chilled liquid temperature is at or above setpoint run is initiated and the chilled liquid and Condenser pump contacts close. The chilled and condenser liquid flow switches are bypassed for 30 seconds each after the respective pump contacts close, or until the respective flow switch closes, if less than 30 seconds. If the unit is kept from starting because the leaving liquid temperature is below setpoint, a cycling shutdown shall be initiated.

For Low Leaving Chilled Liquid Temperature (LCHLT) shutdowns only, the system starting temperature is determined by adding 2.0°F(1.1°C) to the leaving chilled water setpoint.

If the condenser or chilled liquid flow switch does not close within 30 seconds of the pump contacts closure, a safety shutdown is performed.

When run conditions are met and flow switches closed for 2 continuous seconds, startup continues as follows:

If the unit is equipped with Franklin Pumps, the steam/hot water shut-off valves are energized and the refrigerant pump and generator pump (50 Hz Models YIA-10E3 - YIA-14F3) are started.

If the unit is equipped with Buffalo pumps, refrigerant pump operation is controlled by float/level switches 1F and 3F. The refrigerant pump is not started until both refrigerant level float switches 3F and 1F close and the “REFRIGERANT PUMP STARTUP DELAY” setpoint timer has elapsed as follows: The refrigerant level will rise to a level that causes 3F to close. As the level continues to rise, it will cause 1F to close. When 1F closes, the REFRIGERANT PUMP STARTUP DELAY setpoint timer is started. If 1F remains closed for the duration of the timer, the refrigerant pump is started when the programmed delay has elapsed.

After the refrigerant pump has been started, if the refrigerant level decreases to the extent that first 1F opens and then 3F opens, the REFRIGERANT PUMP SHUTOFF DELAY setpoint timer is started when 3F opens. If 3F remains open for the duration of the timer, the refrigerant pump is shut off after the programmed delay has elapsed. When the unit first enters SYSTEM RUN or after a refrigerant pump shutdown has occurred due to low refrigerant level, the Chiller REFRIGERANT LEVEL SHUTDOWN setpoint timer is started. The programmed value is the number of minutes the unit is allowed to run without the refrigerant pump running. If the refrigerant pump is not started before the timer has elapsed, a safety shutdown is initiated.

To assure that both 1F and 3F float/level switches are operational, the program compares the state of 1F to 3F. Since each float/level switch closes as the refrigerant level rises against it and opens when the level decreases below the device, and 1F is at a higher level than 3F, it is not possible that 1F would be closed if 3F is still open; unless one of the switches is malfunctioning. If this condition is detected, a warning is displayed.

The unit will perform a cycling shutdown without initiating dilution when LCHLT is less than LCHLT Setpoint - LCHLT Shutdown Setpoint (see Setpoints Section). During this shutdown, dilution is initiated if the strong solution temperature drops below a calculated value for crystallization. When the local entered LCHLT setpoint is manually changed, LCHLT must be below both the new and previous LCHLT setpoint values by the offset amount to initiate cycling shutdown until 30 minutes have elapsed from the time of change. After 30 minutes, low LCHLT cycling shutdown is based only on the new

setpoint. This allows the chiller to remain running while adjusting LCHLT to a new setpoint. If a setpoint change is entered more than once within 5 minutes of the first entry, the final entry is considered a single change and the control works to that value and the value before any entry changes were made. The 30 minute delay for cycling shutdown temp entered does NOT apply to remote command setpoint changes.

The unit can be stopped at any moment by pressing the main switch to the stop position, by receiving a stop order remotely when the unit is in remote mode, when there is a scheduled stop or by requesting a soft shutdown on the user interface.

When the unit is stopped using the main switch or by applying a scheduled stop, the control valve closes and a dilution cycle is performed immediately. When the unit is stopped remotely with a soft shutdown selected or by a local soft shutdown. The loading of the unit will be linearly decreased on a user programmed ramp down time to the valve unload limit (programmed at SERVICE access from 10% to 20%) before shutting the unit down, and then a dilution cycle is performed. This results in less shock to the customer's steam/hot water supply system.

Once the Soft Shutdown initiates ramp down, it will continue until the user defined unloading threshold is met, regardless of any run/stop status change before shutdown.

If the unit is operating under a load condition that is equal to the low unload limit setpoint, when the soft shutdown is initiated, the unit will go into an instant shutdown.

Automatic Load Control

Three subcontrols interacting constantly determine load valve position. They are "Leaving Chilled Liquid Temperature Control (LCHLT Control)", "Strong Solution Control (SCC Control)" and load limits. The control performs an analysis of all of them and never exceeds the lowest limit.

Leaving Chilled Liquid Temperature (LCHLT) Control

The "Leaving Chilled Water Temperature Control" is a fuzzy logic control, to match the leaving chilled liquid temperature with leaving chilled liquid temperature setpoint.

Strong Solution Concentration (SSC) Control

The "Strong Solution Concentration Control" is a fuzzy logic control; to avoid the unit reaching concentrations that can crystallize the solution.

Load Limits

Additionally, the following limits may exist:

- Pulldown Limit Active; if True, the control limits the max. load to the pulldown current load value.
- Soft shutdown in process; if True, the control limits the max. load to the ramp down current load value.
- Remote Control active; if True, the load should NOT be more than remote load limit setpoint.
- Warning activated; panel will display a warning message that is further explained in the Messages Section of this manual.
- Max. Load Limit; programmed valve position limit.

Limiting Capacity by mixing Solution & Refrigerant

Isoflow chillers are equipped with provisions to accommodate low load operation (down 10%) with cooling water temperature as low as 45°F (7.2°C). Achievement of low capacity at low cooling water temperature requires reduction of concentration in the solution circuit. Water from the refrigerant circuit is added to the solution circuit for dilution naturally by operating the unit at low load.

Further load reduction occurs by sending Lithium Bromide under a controlled basis to the refrigerant circuit. The amount of actual Lithium Bromide transferred is kept to a minimum by introducing this Lithium Bromide only when the refrigerant level in the refrigerant circuit is at a minimum operational level.

The unloader valve (3SOL) is opened when the upper refrigerant float/level switch (1F) opens and the leaving chilled water temperature is greater than 2°F above setpoint. This temperature threshold prevents transfer of solution during possible low refrigerant level at start-up by blocking out the operation of 3SOL until the chilled water temperature is within range of normal operation.

The refrigerant level solenoid (unloader control) 3SOL Valve is energized (open) to transfer solution from the solution (absorber on 50Hz models YIA-10E3 - YIA 14F3 with Franklin Pumps) pump discharge to the refrigerant pump suction when a low level of refrigerant would otherwise cause refrigerant pump cavitation.

During normal operation where at least medium load prevails, Lithium Bromide in the refrigerant circuit is NOT required. The YIA unit provides means for Lithium Bromide removal from the refrigerant circuit as load is increased.

During operation, the refrigerant temperature sensor (RT8), which is continuously monitored and displayed, provides several control functions. If the refrigerant temperature falls to 35.5°F (1.9°C), the stabilizer refrigerant solenoid valve (2SOL) is energized (open) on units equipped with Franklin pumps; if the unit is equipped with Buffalo pumps, it will be energized only if the refrigerant pump is running. This transfers refrigerant to the generator's solution outlet line to reduce the concentration, thus reducing the cooling capacity of the unit. This lessens the possibility of crystallization. Simultaneously, unit loading is inhibited to 50% valve position. If the temperature falls to 34.0°F (1.1°C), the solution (absorber on 50 Hz Models YIA-10E3 – YIA-14F3 with Franklin pumps) pump turns off; this should allow the refrigerant temperature to rise. If the refrigerant temperature rises to 35.5°F (1.9°C), the solution pump turns on. If the refrigerant temperature rises to 36.0°F (2.2°C), the stabilizer refrigerant solenoid valve is de-energized (closed), and the unit loading inhibit is removed.

However if the refrigerant temperature continues to fall, a low refrigerant temperature safety shutdown occurs at 33.0°F (.5°C). If the unit experiences a shutdown when the refrigerant temperature is 34°F (1.1°C) or below, the chilled liquid pump contacts remain closed for a minimum of 30 minutes. Subsequently, when the refrigerant temperature rises to 37.0°F (2.8°C), the dilution cycle begins.

The motor coolant solenoid valve (units with Franklin pumps only) is energized (open) whenever the strong solution temperature is above 160°F (71.1°C) (this threshold is programmable from 127°F to 160°F (52.8 to 71.1°C); the threshold should only be programmed by a qualified service technician.

The motor coolant solenoid valve is de-energized (closed) whenever the strong solution temperature is below the programmed open threshold minus 10°F. The purpose of the valve is to prevent evaporation of water from the coolant reservoir during unit shutdown or when the unit operates at low load and low condensing water temperatures. However, if the refrigerant and solution (absorber and generator on 50 Hz Models YIA-10E3 – YIA-14F3 with Franklin pumps) pump motor coolant level float switch opens, the unit locks out on a safety shutdown.

Dilution Cycle Operation

A dilution cycle is performed every time the chiller is cycled off or shutdown. The purpose of the dilution cycle is to prevent the solution from crystallization while the chiller is off by reducing the solution concentration. The goal is to reduce the concentration down to 57° (13.8°C) at which the crystallization temperature is near 35° F (1.6°C). A dilution cycle will occur at most unit shutdowns. A typical dilution cycle will operate the refrigerant, solution, generator (Franklin pumps 10E3 – 14F3 only), condenser and chilled liquid pumps with the control valve fully closed. When a dilution cycle is performed, the evaporator continues generating vapor and the absorber continues the mass transfer by absorbing the vapor, but the rate produced in the generator is reduced drastically because the control valve is closed.

The Mod “D”, YIA absorption chiller is capable of performing four different dilution cycles:

1. Normal dilution
2. Manual dilution
3. Limited dilution
4. Short dilution

Normal Dilution Cycle – is performed when the short dilution cycle is disabled and unit is under either leaving chilled liquid temp (LCHLT) control or strong solution concentration (SSC) control. The control valve will close and all pumps; solution, refrigerant, generator (Franklin pumps 10E3 – 14F3 units only), condenser and chilled liquid will continue to run for 6 minutes. The normal dilution cycle will terminate after the 6 minute interval is complete. A normal dilution cycle is independent of the solution concentration at the start of the dilution cycle. A normal dilution cycle will initiate in all three control panel access levels (View, Operator, or Service). The following conditions will pre-maturely terminate the normal dilution cycle.

Condition	System Details Display Message
Chilled liquid flow opens greater than 2 seconds	Dilution cycle interrupted – chilled water off
Condenser water flow opens greater than 30 seconds	Dilution cycle interrupted – Cond water off
Solution pump contacts open	Solution pump overloads open
Refrigerant pump contacts open	Refrigerant pump overloads open
34°F (1.1°C) less than refrigerant temp less than or equal to 35.5° (1.9°C)	Low refrigerant temp RT8 is less than 35.5°F (1.9°C)
33°F (.55°C) less than refrigerant temp less than 34°F (1.1°C)	Low refrigerant temp RT8 is less than 34°F (1.1°C) solution pump is off
Refrigerant temp less than or equal to 33°F (0.56°C)	Low refrigerant temp analog RT8 is less than 33°F (0.56°C)
Low refrigerant temp safety device open	Low refrigerant temp digital LRT opened
Strong solution temp greater than 330°F (166°C)	Generator Hi temp analog switch RT3 is greater than 330°F (166°C)
Generator High temp safety device open	Generator Hi temp digital switch HT1 opened – Man reset
3F opening = ref pump shutdown delay setpoint	After 30 sec. delay, dilution cycle terminated – switch 3F opened.
Motor coolant float switch is open for 0.5 sec. (units with Franklin pumps only)	Low motor coolant level - MCFL switch opened
Generator shell pressure is greater than or equal to 672mmHg (analog)	Generator Hi pressure analog switch PT1 greater than 672 mmHg
High pressure (digital) safety device open	Generator Hi-Pressure digital switch HP1 open
Auxiliary safety shutdown contact is open	Auxiliary safety shutdown
Remote/Local cycling contact is open	Unit shutdown by remote device
Multi-Unit cycling contact is open	Unit shutdown by multi-unit remote

Manual Dilution Cycle – is only available in the “Systems” screen when the panel is set to “Service” access level. The manual dilution key will NOT show in the “View” or “Operator” access level screens. When the manual dilution key is pressed when the unit is not running (unit switch in stop position), a pop up box will appear to confirm the start of the manual dilution cycle. Press the “✓” key to confirm the dilution cycle and the refrigerant, solution, generator (Franklin pumps 10E3 – 14F3 only), condenser and chilled liquid pumps will operate for 6 minutes. To terminate the dilution cycle press the manual dilution key again and confirm “Stop dilution cycle (Yes/No)” by pressing the “✓” key in the pop up box.

Condition	System Details Display Message
Chilled liquid flow opens is greater than 2.0 seconds	Dilution cycle interrupted – chilled water off
Condenser water flow opens is greater than 30 seconds	Dilution cycle interrupted – Cond water off
Solution pump contacts open	Solution pump overloads open
Refrigerant pump contacts open	Refrigerant pump overloads open
Refrigerant temp is less than or equal to 33°F (0.56°C)	Low ref temp analog RT8 is less than 33°F (0.56°C)
Low refrigerant temp safety device open	Low ref temp digital LRT opened
Generator High temp safety device open	Gen hi-temp dig switch HT1 opened – man reset
3F open = ref pump shutdown delay setpoint	Dilution cycle interrupted – switch 3F opened Ref level switch conflict - CHK 1F & 3F
Motor coolant float switch is open for 0.5 sec. (units with Franklin pumps only)	Low motor coolant level - MCFL switch opened
Generator shell pressure is greater than or equal to 672mmHg (analog)	Generator Hi pressure analog switch PT1 is greater than 672 mmHg
High pressure (digital) safety device open	Generator Hi Pressure digital switch HP1 open
Auxiliary safety shutdown contact is open	Auxiliary safety shutdown
Remote/Local cycling contact is open	Unit shutdown by remote device
Multi-Unit cycling contact is open	Unit shutdown by multi unit remote

Limited Dilution Cycle – A limited dilution cycle was created for power failure situations when the unit is connected to a stand-by generator. A limited dilution will only operate the solution pump or generator pump (Franklin pump 10E3 – 14F3 units only) for a four hour time period to conserve energy. It will not operate the chilled liquid pump or condenser tower water pump during this period. If the condenser flow switch closes, (indicating flow) the limited dilution cycle will terminate. If the chilled water pump flow switch closes, the limited dilution cycle will continue. During a limited dilution cycle, the unit will continue to monitor if the fault condition has been cleared to switch to a normal dilution cycle.

Short Dilution Cycle – The short dilution cycle option must be enabled under the “Setpoints” screen in Service access level. Upon unit shut down, the software logic will monitor the strong solution temperature taken at RT10 and compare this to the solution concentration crystallization point. The duration period of the short dilution cycle will be as follows:

Concentration	Pumps operation duration	2SOL opening duration
Less than 57%	60 seconds	N/A
57% - 59%	70 seconds	50 seconds
59% - 61%	110 seconds	90 seconds
61% - 63%	170 seconds	150 seconds
63% - 65%	200 seconds	180 seconds
Greater than 65%	230 seconds	210 seconds

Depending on the solution concentration, the 2SOL (stabilizer) solenoid valve will open to allow refrigerant from the discharge side of the refrigerant pump to mix with the solution returning from the generator to accelerate the dilution process. This feature cannot be enabled during a power failure. All pumps; solution, refrigerant, generator (Franklin pumps 10E3 – 14F3 units only), condenser and chilled liquid will run during a short dilution cycle.

Purge Process

The YIA OptiView™ control handles 4 purge operation modes, they are Auto, Manual, Maintenance, and Repair. The chiller continually separates non-condensables to the purge tank, regardless of mode. If these non-condensables are NOT removed from the system they will collect in the absorber section and blanket the tubes. This blanketing will prevent the tubes from making the necessary mass transfer of refrigerant from the evaporator section, thus reducing the units capacity.

The mode determines how to clear the purge tank.

- Auto-purge mode enables the unit able to clear the purge tank by itself and monitor its performance.
- Manual purge mode allows the operator to clear the purge tank when necessary.
- Maintenance mode allows the operator to change the purge pump oil.

Repair mode gives the service technician full freedom for all purge device operation. It allows troubleshooting and also allows operation to purge directly from the evaporator-absorber shell, which is helpful in the unit start-up process.



To reduce the risk of injury, never operate the purge pump with the belt guard removed!



Extreme caution must be taken when performing a purge process. Never allowing air to enter the unit at any time.

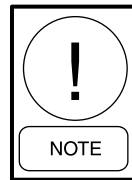

The auto-purge system can start and stop automatically; even when the unit is NOT running.

Smart Purge

The smart purge system is a new addition to the YIA chiller product line. Smart purge system features include:

- Purge warm-up setpoint. This setpoint will allow the purge pump oil to warm-up before opening 8SOL. It can be programmed from 2 minutes to 20 minutes, default being 2 minutes. If the purge pump was running within 50 minutes prior to an additional start-up, the warm-up period will default to 2 minutes.
- The YIA auto-purge trigger pressure will be 80mmHg Abs, it will evacuate the purge tank to 30mmHg Abs.
- Continuous monitoring of the purge pump performance.
- Continuous monitoring of the purge tank pressure.
- Excess purge warning

- Purge trending
- Post purge "Oil Clean-up"

The logic to control the YIA auto-purge is ONLY available on units equipped with an OptiView Control Panel. Therefore there can be NO retrofitting of an auto-purge system on older units unless it is equipped with an OptiView Control Panel.

Mode	Control Source	Min. Access Level Req'd.
Auto	Local/Remote	View
Manual	Local/Remote	Operator
Repair	Local/Remote	Service
Maintenance	Local/Remote	Operator

The YIA purge system will collect any non-condensables in the absorber section and store them in a unit mounted purge tank. At a predetermined purge tank pressure, the non-condensables will be expelled to the atmosphere by a unit mounted purge pump. The YIA auto-purge will also monitor, record and trend the amount of purges in any given time.

Manual Purge

It may be necessary to manually purge the unit mounted purge tank. The manual mode allows the operator to perform this function. The manual purge can be performed from the OptiView control panel independent of unit operation. The pump can be turned on in either the Operator or Service modes.

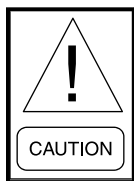

Before initiating a manual purge, VP2 must be opened and VP4 closed.

From the HOME screen select the PURGE key to navigate to the Purge Screen. Select MAN/AUTO so the purge field box displays "MANUAL". Press the "ON" key and the purge pump will operate for 2 to 20 minutes depending on the duration of the Purge Warm-up setpoint (default is 2 minutes). If the purge pump was operated in the past 50 minutes, the purge warm-up will be 2 minutes. Purge pump solenoid valve (8SOL) and purge tank solenoid valve (7SOL) will be closed at this time.

After the pre-programmed purge warm-up period has timed out the purge pump solenoid valve (8SOL) will begin to open and a 1 minute timer will initiate. After the 1 minute timeout, the pressure at purge pump pressure

transducer (PT3) must be equal to or less than 15mm Hg Abs. If not, the purge pump will continue to run for an additional minute. If during this additional minute, the pressure at PT3 reaches 15mm Hg Abs or less, purge tank solenoid (7SOL) will open. If not, purge pump solenoid valve (8SOL) will close and the purge pump continues to run for 65 seconds. This allows time for purge pump solenoid valve (8SOL) to fully close. The panel will display a warning message that is further explained in the Messages Section of this manual.

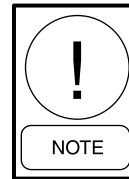

During the 65 second pump shut-off delay, manual turn OFF of the purge pump is prevented.

If at anytime during the manual purge process, the purge pump pressure at PT3 or purge tank pressure (PT4) reaches 100mm Hg Abs or higher, both the purge pump solenoid valve (8SOL) and purge tank solenoid valve (7SOL) will close. The purge pump will run for another 65 seconds then shutdown and the panel will display a warning message that is further explained in the Messages Section of this manual.

Once purge tank solenoid valve (7SOL) is opened, non-condensables stored in the Purge Tank will be expelled to the Atmosphere by the Purge Pump. The OptiView logic monitors this process and if a decrease in pressure at the Purge Tank (PT4) is NOT seen every 6 seconds, the panel will initiate a purge failure.

A warning message will be displayed (further explained in the Message Section of this manual) and both Purge Tank Solenoid Valve (7SOL) and the Purge Pump Motorized Ball Valve (8SOL) will close and the Purge Pump will run for an additional 65 seconds before shutting off.

The Manual Purge will continue until Purge Tank Transducer (PT4) reads 20mmHg Abs. At that time the manual purge will initiate a normal shutdown by closing Purge Tank Solenoid (7SOL) and Purge Pump motorized Ball Valve (8SOL). The Purge Pump will continue to operate for a post purge oil clean-up for 10 minutes.

After the manual purging is finished, press the "PURGE PUMP" key to activate purge pump field then press the "OFF" key to shut off the pump. The pump will continue to run for an additional 10 minutes for a post purge clean-up.

When the post purge cleaning process finishes, the purge pump is turned off and the last 7 days manual purge counter and the total manual purge counter is increased by 1.

The manual purge can be stopped by the user at any moment, but the manual purge counters will NOT be increased if the (7SOL) (8SOL) valves are still closed. When the manual purge is manually stopped, the control will close (7SOL) and (8SOL) and run the pump for 65 seconds.

Auto Purge

When the unit mounted purge tank pressure transducer, PT4 reaches 80mm Hg Abs, the auto purge sequence is triggered. The purge pump will start and run for the pre-programmed purge warm-up period. If no pre-programmed time period has been entered the default will be 2 minutes. If the purge pump was operated in the past 50 minutes prior to the auto purge sequence, the "Purge warm-up period" will be 2 minutes. After the purge pump warm-up setpoint time has expired, purge pump solenoid (8SOL) will start to open and a 1 minute timer will initiate.

After 1 minute the pressure at purge pump pressure transducer (PT3) is read. If this pressure is 15 mm Hg Abs or less, purge tank solenoid (7SOL) will open. If not, the purge pump will continue to run for an additional minute. If during this additional minute, the pressure at PT3 reaches 15 mm Hg Abs or less, purge tank solenoid (7SOL) will open. If not, purge pump solenoid valve (8SOL) will close and the purge pump continues to run for 65 seconds. Please note during the 65 second pump shut-off delay, manual turnoff of the purge pump is prevented. This allows time for purge pump solenoid valve (8SOL) to fully close. The panel will display a warning message that is further explained in the Messages Section of this manual.

Once purge tank solenoid (7SOL) is opened, non-condensables stored in the purge tank will be expelled to the Atmosphere via the purge pump. The OptiView logic monitors this process and if a decrease in pressure at the purge tank (PT4) is NOT seen every 6 seconds, the panel will initiate a purge failure.

A warning message will be displayed (further explained in the Messages Section of this manual) and both Purge Tank Solenoid Valve (7SOL) and Purge Pump Motorized Ball Valve (8SOL) will close and purge pump will run for another 65 seconds before shutting off.

Once the purge tank pressure transducer (PT4) reads 30 mm Hg Abs, both 7SOL and 8SOL will close. The purge pump will continue to run for another 10 minutes for a post purge oil clean-up then shut off.

When the post purge cleaning process finishes, the last 7 day auto purge counter and total auto purge counter will increase by 1.

If at anytime during the manual purge process, the purge pump pressure at PT3 or purge tank pressure (PT4) reaches 100 mm Hg Abs or higher, both the purge pump solenoid valve (8SOL) and purge pump solenoid valve (7SOL) will close. The purge pump will run for another 65 seconds then shut down and the panel will display a warning message that is further explained in the Messages Section of this manual.

Maintenance Purge

The maintenance purge mode is intended exclusively for the unit operator to periodically change the purge pump oil. Periodic oil changes are necessary to maintain efficient operation of the system. The purge pump should always be operated with the gas ballast open to prevent refrigerant vapor from condensing in the oil.

An indication of when the oil in the purge pump needs changed is when the oil in the sight glass becomes yellowish or milky in color. A purge pump capacity test may also be an indicator, but this is not recommended for the operator to perform.

It is recommended to warm-up the purge pump oil for a minimum of 10 minutes to reduce the viscosity of the oil prior to draining.

Enter the "Operator" access level by entering the operator code "9675" and proceed to the "Purge Screen". Pressing the "Maintenance" key at the bottom of the screen will change the purge mode to "Maint" and will allow the pump to be started manually. The 8SOL and 7SOL valves will not open while the pump continues to run.

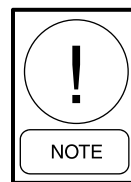

Once the pump is started in this manner the pump will continue to run until it is manually shut off. Before proceeding to any other purge mode, ensure the purge pump is not running.

Purge Mode Changes

When the purge mode is changed, 7SOL and 8SOL are closed. If NOT closed the purge pump will continue to run an additional 65 seconds, if it was running.

If the purge mode is changed to "REPAIR", it is possible to purge either the purge tank or the evaporator-absorber shell. Another option could be to test the purge line for any leaks and verify pump performance without purging the unit.

- Purging the purge tank: open VP2, close VP4.
- Purging the shell: Close VP2 and open VP4 (VP2 could be open if it desired to make a faster vacuum).
- Testing the purge line or the purge devices; Close VP2, and VP4.

Auto-Decrystallization Process

The auto-decrystallization process is triggered when the ADC pipe temperature sensed by RT2 is greater than 160°F (71°C) and 3F float/level switch is closed (enough refrigerant level exists for the refrigerant pump). The auto-decrystallization line provides an alternate path for the strong solution from the generator.

If a situation starts to develop such that solution concentration from the generator is excessively high, solution crystals will start to build on the shell side of the heat exchanger. This will restrict the flow through the normal line of solution return from the generator, then the solution level will increase in the overflow box until it reaches the auto-decrystallization line.

- This process sets the control valve opening to 50% to decrease the concentration in the solution.
- Open Stabilizer Valve (2SOL) valve 2 minutes every 10 minutes.
- 3F float switch is closed (enough refrigerant level exists for the refrigerant pump).
- If 3F level switch opens, stops the auto-decrystallization process and starts the limited auto-decrystallization process.
- Reviews the temperature at RT2 every 10 minutes, if it is less than 150°F (65°C), the control assumes that the unit has been decrystallized and returns to running mode.
- During a soft shutdown, if the unit were to go into an ADC mode, and the unit control valve is greater than 50% open, the valve will be immediately be driven to the 50% position. The soft shutdown will continue from the 50% position. The unit will go into a mandatory 6 minute dilution cycle if shutdown during ADC.

Limited Auto-decrystallization

The limited auto-decrystallization process is triggered when the temperature sensed by RT2 is greater than 160°F (71°C), and 3F float switch is open (insufficient refrigerant level for the refrigerant pump).

- This process sets the valve opening to 50% to decrease the concentration in the solution.
- Monitors 3F and 1F level switches, if both level switches are closed, stops the limited decrystallization process and starts the normal auto-decrystallization process.
- This process lasts until the 10 minute ADC timer that was running when Limited Auto-decrystallization started has completed.

Secondary Limited Auto-decrystallization

The secondary limited auto-decrystallization process is called by the limited auto-decrystallization process when it finishes and the temperature sensed by RT2 is greater than 150°F (65.5°C), and the 3F level switch is open.

- This process closes the control valve, because the machine is NOT capable of adding refrigerant to the solution via 2SOL.
- Monitors 3F and 1F level switches, if both level switches are closed, stops the secondary limited auto-decrystallization process and starts the auto-decrystallization process.
- This process last 15 minutes. If the temperature sensed by RT2 is less than 150°F, the control assumes that the unit has been decrystallized and returns to running mode, if NOT, the control sets the machine in safety shutdown.

UNIT OPERATION UNDER POWER FAILURE CONDITION USING AN EMERGENCY POWER SUPPLY

When the chiller has an emergency power supply, this feature helps prevent crystallization if there is a power failure. This feature manages the unit in three states:

- The unit is already diluted
- The unit is NOT diluted and it is possible to perform a limited dilution cycle
- The unit is NOT diluted and it is NOT possible to perform a limited dilution cycle because there was a safety shutdown that does NOT allow the starting of the solution pump.

All pumps are turned OFF and all valves are closed, the control does NOT allow any manual operation of the machine and waits until the unit has normal power supply. After that, the unit is ready to start.

OPTIVIEW CONTROL CENTER

The OptiView™ Control Center display is highlighted by a full screen graphics display. This display is nested within a standard keypad, and is surrounded by “soft” keys which are redefined based on the currently displayed screen. Eight buttons are available on the right side of the panel, and are primarily used for navigation between the system screens. At the base of the display are 5 additional buttons. The area to the right of the keypad is used for data entry with a standard numeric keypad provided for entry of system setpoints and limits.

 The **Decimal** key provides accurate entry of setpoint values.

 A +/- key has also been provided to allow entry of negative values and AM/PM selection during time entry.

 In order to accept changes made to the chiller setpoints, the **Check** key is provided as a universal "Enter" or "Accept" symbol.

 In order to reject entry of a setpoint or dismiss an entry form, the **X** key is provided as a universal "Cancel" symbol.

 **Cursor Arrow** keys are provided to allow movement on screens which contain a large amount of entry data. In addition, these keys can be used to scroll through history and event logs.

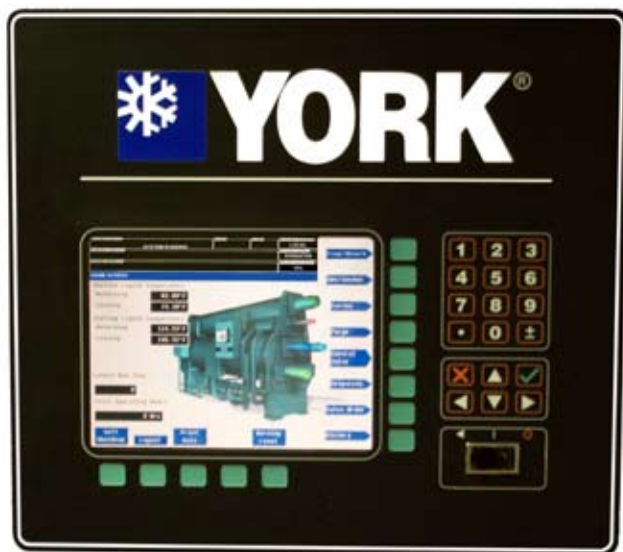

29348A

FIGURE 3 - OPTIVIEW CONTROL CENTER

The Start/Stop control is operated via a three-position rocker/rotary switch. When toggled all the way to the right, it is considered in the **STOP/RESET** position. When in the middle position, this is considered the **RUN** state. When toggled to the left-most position, it is considered in the **START** state. Each state is described in detail below:

- **STOP / RESET (O)**
When in this position, the chiller will not run under any condition. For safety reasons, this position is required for many maintenance tasks to be completed. In addition, the switch must be placed in this state following a Safety shutdown before the chiller is allowed to restart. This guarantees that manual intervention has taken place and the shutdown has been acknowledged.

- **START (◀)**
The switch can only remain in this position when being acted upon by a manual force. Once the user has released the switch, it automatically reverts to the RUN position. Generally, this state only occurs momentarily as the operator attempts to locally start the unit. Once this position has been sensed, if all fault conditions are cleared, the unit will enter the system start sequence.

- **RUN (■)**
When in this position, the chiller is able to operate. The switch spring-returns to this state after it has been toggled to the **START** position. When in this state, the chiller is allowed to function normally, and will also allow the chiller to automatically restart following a Cycling shutdown. The switch must be in this state to receive a valid remote start signal when operating under a remote control source.

INTERFACE CONVENTIONS

Overview

The new graphical display on each control panel allows a wide variety of information to be presented to the user. Each screen description in this document will begin with a section entitled **Overview** which will describe the graphical elements on the screen and give a short summary of the functions available. Each element on the screen will then be categorized into three distinct groups: Display Only, Programmable, and Navigation. Below is a short description of what types of information are included in these groups.

The Programmable values and Navigation commands are also subject to access level restrictions as described below. For each of these elements, an indication is given to show the minimum access level required to program the value or navigate to the sub-screen.

Display Only

Values in this group are read-only parameters of information about the chiller operation. This type of information may be represented by a numerical value, a text string, or an LED image. For numerical values, if the monitored parameter is above the normal operating range, the high limit value will be displayed along with the ">" symbol; if it is below the normal operating range, the low limit value will be displayed along with the "<" symbol. In some cases, the value may be rendered invalid by other conditions and the display will use X's to indicate this.

Programmable

Values in this group are available for change by the user. In order to program any setpoints on the system, the user must first be logged in with the appropriate access level. Each of the programmable values requires a specific Access Level which will be indicated beside the specified value. All of the programmable controls in the system fall into one of the categories described below:

Access Level

In order to program any setpoints on the system, the user must first login with an appropriate access level. When power is applied to the chiller, the system begins with an Access Level of **VIEW**. This will allow the user to navigate to most screens and observe the values displayed there. However, the user will not be allowed to change any values. To change any values, the user must return to the **Home Screen** (shown by default when power is applied to the system), and use the **LOGIN** key or utilize the **CHANGE SETPOINTS** key described below. At

this point, the user will be prompted to enter a User ID and the corresponding Password. By default, the User ID is zero (0). In order to gain standard **OPERATOR** level access, the Password would be entered as **9 6 7 5**, using the numeric keypad. **OPERATOR** access reverts to the **VIEW** level after 10 continuous minutes without a keypress. If a custom User ID and Password have been defined (see User Screen), the user may enter that User ID and the corresponding password value.

If the correct password is received, the user is authorized with the appropriate Access Level. If an incorrect password is entered, the user is notified of the failure and prompted again. At this point the user may retry the password entry, or cancel the login attempt.

Change Setpoints

On the Setpoints Screen, a Login key will be visible if the present access level is **VIEW**. This key brings up the Access Level prompt described above. It allows the user to login at a higher Access Level without returning to the Home Screen. After login, the user may then modify setpoints on that screen.

Setpoints

The control center uses the setpoint values to control the chiller and other devices connected to the chiller system. Setpoints can fall into several categories. They could be numeric values (such as 44.0°F (6.6°C) for the Leaving Chilled Liquid Temperature), or they could Enable or Disable a feature or function.

Regardless of which setpoint is being programmed, the following procedure applies:

1. Press the desired setpoint key. A dialog box appears displaying the present value, the upper and lower limits of the programmable range, and the default value.
2. If the dialog box begins with the word "ENTER", use the numeric keys to enter the desired value. Leading zeroes are not necessary. If a decimal point is necessary, press the "." key (i.e. 45.0).

Pressing the ▲ key, sets the entry value to the default for that setpoint. Pressing the ▼ key, clears the present entry. The ◀ key is a backspace key and causes the entry point to move back one space.

If the dialog box begins with "SELECT", use the ◀ and ▶ keys to select the desired value.

If the previously defined setpoint is desired, press the "X" (Cancel) key to dismiss the dialog box.

3. Press the "✓" (Enter) key.

If the value is within range, it is accepted and the dialog box disappears. The chiller will begin to operate based on the new programmed value. If out of range, the value will not be accepted and the user is prompted to try again.

Manual Controls

Some keys are used to perform manual control functions. These may involve manual control of items such as the control valves, solenoid valves, and other keys in this category are used to initiate/terminate processes such as calibrations or reports.

Free Cursor

On screens containing many setpoints, a specific "soft" key may not be assigned to each setpoint value. A soft key will be assigned to enable the cursor arrow keys below the numeric keypad which are used to "highlight" the desired setpoint field. At this point, the "✓" key is pressed to bring up a dialog prompting the user to enter a new setpoint value. The "X" key cancels cursor mode.

NAVIGATION

In order to maximize the amount of values which the panel can display to the user, and in order to place those values in context, multiple screens have been designed to describe the chiller operation. In order to move from one screen to the next, navigation keys have been defined. These keys allow the user to either move "forward" to a sub-screen of the present screen, or move "backward" to the previous screen. Except for the Home Screen display, the upper-right "soft" key will always return the user to the Home Screen. Navigating with "soft" keys is as simple as pressing the key next to the label containing the name of the desired screen. The system will immediately refresh the display with the graphics for that screen.

LANGUAGES

The Screens can be displayed in various languages. Language selection is done on the CONFIGURE Screen. The desired language is selected from those available. Not all languages are available. English is the default language. If a language other than English is being displayed, an English-only speaking person should navigate to the CONFIGURE Screen using the preceding Navigation chart and select English per the CONFIGURE Screen instructions in this book.

YIA OptiView Navigation

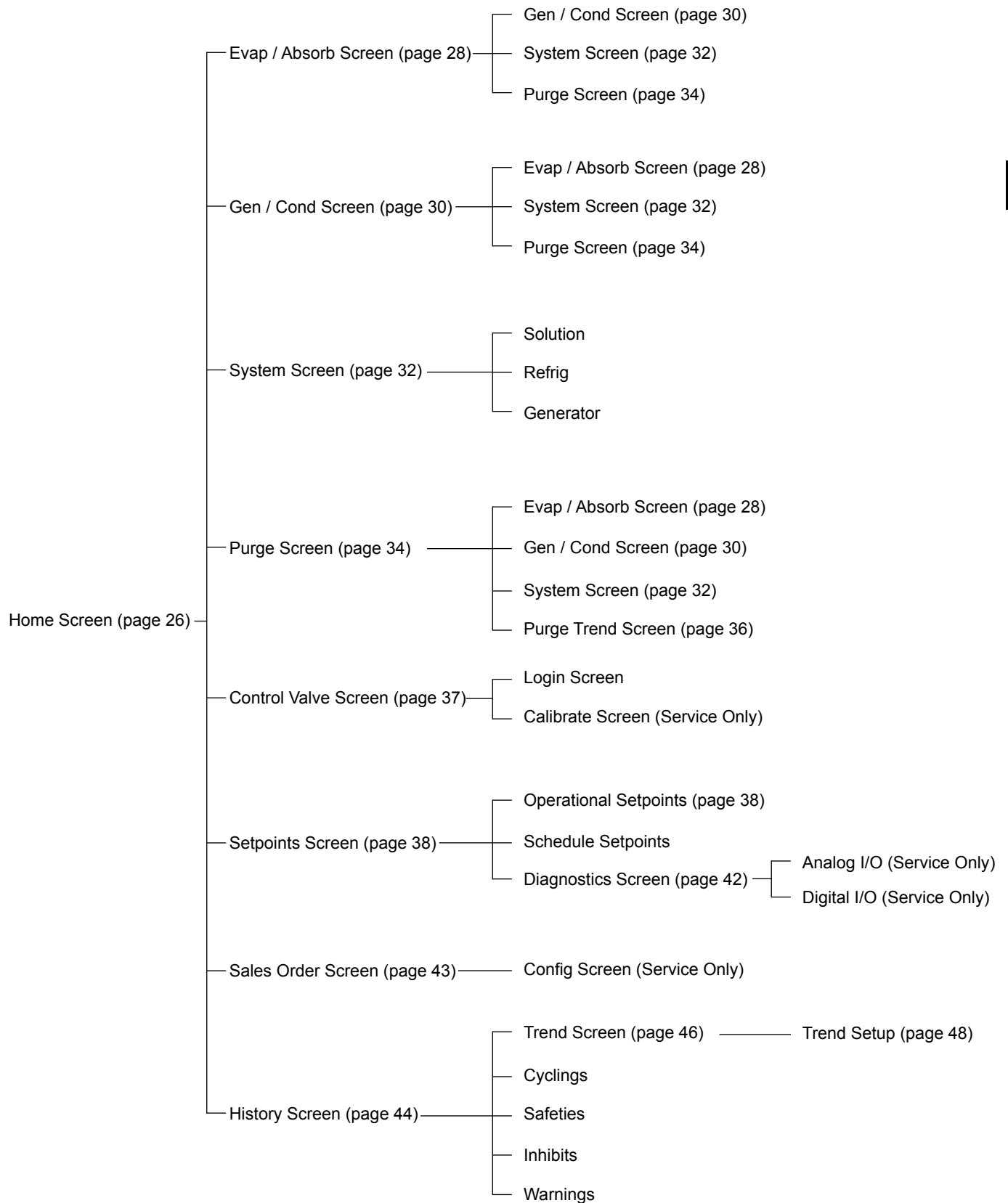

FIGURE 4 – YIA OPTIVIEW NAVIGATION

ANALOG INPUT RANGES

The following table indicates the valid display range for each of the analog input values. In the event that the input sensor is reading a value outside of these ranges, the < or > symbols will be displayed beside the minimum or maximum value, respectively.

TABLE 1 – ANALOG INPUT RANGE

Analog Parameter	Device	English Range			Metric Range		
		Low	High	Units	Low	High	Units
Leaving Chilled Liquid Temperature	RT1	0	81	°F	-17.7	27.2	°C
Returning Chilled Liquid Temperature	RT6	0	93	°F	-17.7	33.9	°C
Leaving Cooling Liquid Temperature	RT4	8	134	°F	-13.3	56.6	°C
Returning Cooling Liquid Temperature	RT5	8	134	°F	-13.3	56.6	°C
Evaporator Refrigerant Temperature	RT8	8	134	°F	-13.3	56.6	°C
Generator Pressure	PT1	0	775	mmHg	0	775	mmHg
Entering Steam Temperature	RT7	91	346	°F	32.8	174.4	°C
Entering Steam Pressure	PT2	10	40	PSIA	68.9	275.8	Kpa
Entering Hot Water Temperature	RT7	91	346	°F	32.8	144.4	°C
Strong Solution Temperature	RT3	91	346	°F	32.8	144.4	°C
Strong Solution Concentration	RT3 & RT9	40% *	70% *	%	40% *	70% *	%
ADC Temperature	RT2	100	220	°F	37.8	104.4	°C
Strong Solution Leaving STS Temperature	RT10	60	220	°F	32.8	174.4	°C
Refrigerant from Condenser Temperature	RT9	8	134	°F	-13.3	56.6	°C
Purge Pump Pressure	PT3	12.9	219.7	mmHg	12.9	219.7	mmHg
Purge Tank Pressure	PT4	12.9	219.7	mmHg	12.9	219.7	mmHg

* The calculated strong solution concentration range is from 40% to 70%, this function was copied from the millenium control source code.

THIS PAGE INTENTIONALLY LEFT BLANK

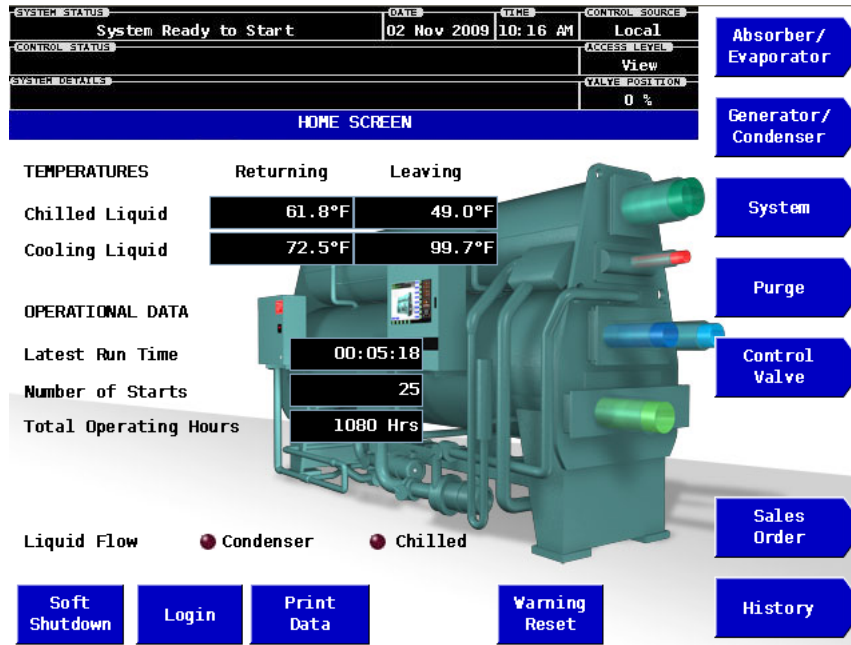

FIGURE 5 - HOME SCREEN

LD13812

HOME SCREEN

Overview

When the chiller system is powered on, the above default display appears. The primary values which must be monitored and controlled are shown on this screen. The Home Screen display depicts a visual representation of the chiller itself. Animation indicates chiller run status.

Display Only

Chilled Liquid Temperature - Returning

Displays the temperature of the liquid as it enters the evaporator.

Chilled Liquid Temperature - Leaving

Displays the temperature of the liquid as it leaves the evaporator.

Cooling Liquid Temperature - Returning

Displays the temperature of the liquid as it enters the absorber.

Cooling Liquid Temperature - Leaving

Displays the temperature of the liquid as it leaves the condenser.

Operating Hours

Displays the cumulative operating hours of the chiller.

Programmable

Login

Access Level Required: VIEW

The OptiView Panel restricts certain operations based on access level and password entry by the operator. Three different access levels are View, Operator, and Service. The access levels are listed in hierarchical order beginning with the lowest level and proceeding to the highest level. Users logged in under higher access level may perform any actions permitted by lower access levels.

VIEW: The panel defaults to the lowest access level which is termed **VIEW**. In this mode, the chiller operating values and setpoints can be observed, but no changes can be made.

OPERATOR: The second access level is termed **OPERATOR** and will allow the customer to change all of the setpoints required to operate the chiller system. The **OPERATOR** access level reverts to the **VIEW** level after 10 continuous minutes without a keypress.

SERVICE: In the event that advanced diagnostics are necessary, a **SERVICE** access level has been provided. Only qualified service personnel utilize this access level. This level provides advanced control over many of the chiller functions and allows calibration of many of the chiller controls.

Login

Access level required: View

This key is displayed when the user is NOT logged in. Pressing the login key will bring up a login screen, allowing OPERATOR and SERVICE access level.

Logout

Access Level Required: OPERATOR or SERVICE

This key is displayed when a user is logged in at any level other than **VIEW**. Pressing it will return the access level to **VIEW**.

Print

Access Level Required: VIEW

Use this key to generate a hard-copy report of the present system status. This provides a snapshot of the primary operating conditions at the time the key is pressed.

Warning Reset

Access Level Required: OPERATOR or SERVICE

Use of this key acknowledges a warning condition and resets the message display associated with it, if the instigating condition is no longer present.

Soft Shutdown

Access Level Required: OPERATOR

Use of this key initiates a gradual shutdown of the chiller, closing the steam/hot water control valve according to the programmable rampdown schedule prior to exiting system run status.

Navigation**Evaporator / Absorber**

Causes an instant return to a detailed view of all Evaporator and Absorber parameters, including the programmable Leaving Chilled Liquid Setpoints.

Generator / Condenser

Causes an instant return to a detailed view of all Generator and Condenser parameters, including Generator pressure, Steam temperature and pressure, and Solution temperature and concentration.

System

Causes an instant return to a detailed view of the status of System Pumps, Liquid Flow details, Solenoid Valves, and Level Switches. Manual operation of these devices is from here.

Purge

Causes an instant return to a detailed view of Purge Pump, Valve status & Purge Tank pressures, Auto-Manual purge counters, & Purge mode. Purge trend is accessed from here.

Control Valve

Causes an instant return to a detailed view of Steam / Hot Water Control Valve specifics and associated calibration.

Setpoints

Causes an instant return to a single location to program the most common system setpoints. It is also the gateway to many of the general system setup parameters such as Date/Time, Display Units, Scheduling, Printer Setup, etc.

Sales Order

Causes an instant return to a detailed view for the specifics of the Absorption Unit, including Model, Serial number, & capacities. Configuration can be accessed from here in SERVICE access.

History

Causes an instant return to a screen that provides access to a snapshot of system data at each of the last 10 safety shutdowns, cycling shutdowns, start inhibits and warning conditions. Graphic system trending is accessed from here.

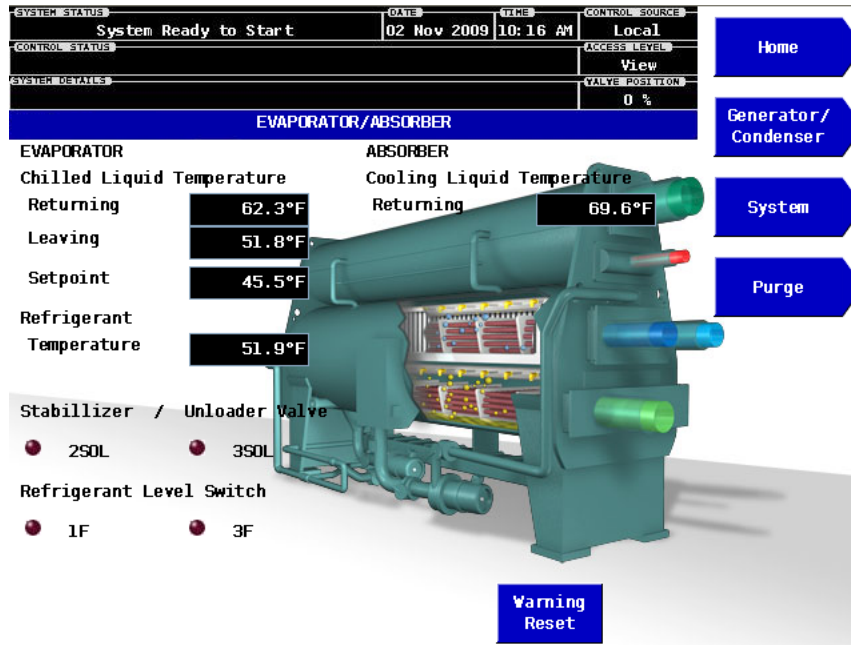

FIGURE 6 - EVAPORATOR / ABSORBER SCREEN

LD13813

EVAPORATOR / ABSORBER SCREEN

Overview

This screen displays a cutaway view of the chiller evaporator and absorber. All setpoints relating to the evaporator side of the chiller are maintained on this screen. Animation of the evaporation process indicates whether the chiller is presently in a **RUN** condition.

Display Only

Evaporator - Chilled Liquid Temperature

Displays the returning, leaving and setpoint chilled liquid temperatures in the evaporator.

Evaporator - Refrigerant

Displays the refrigerant temperature in the evaporator.

Absorber - Cooling Liquid Temperature

Displays the returning cooling liquid temperature to the absorber.

Stabilizer & Unloader Valve

Displays the present position of stabilizer (2SOL) and unloader (3SOL) solenoid valves.

Refrigerant Level Switches

Displays the present positions of 1F and 3F refrigerant level switches.

Programmable

Leaving Chilled Liquid Temperature Setpoint

Access Level Required: OPERATOR

This value allows the user to define the Leaving Chilled Liquid Temperature that is to be maintained by the chiller. It is programmable over the range of 40°F (4.4°C) to 77°F (25°C). A remote device can provide an analog signal (0-10VDC or 115PWM) in Analog Remote, or PWM signal in digital remote mode that changes the setpoint by creating an offset above the operator programmed base Leaving Chilled Liquid Temperature setpoint. This offset may be defined as 10 or 20°F above the base setpoint.

Range: 40.0°F - 77.0°F (4.4°C-25°C)

Default: 42.0°F (5.5°C)

Warning Reset

Access Level Required: SERVICE

This soft key allows the technician to clear the warning message when in SERVICE access.

Navigation

Home

Causes an instant return to the Home Screen.

Gen/Conden

Causes an instant return to the Generator/Condenser Screen.

System

Causes an instant return to the System Screen.

Purge

Causes an instant return to the Purge System Screen.

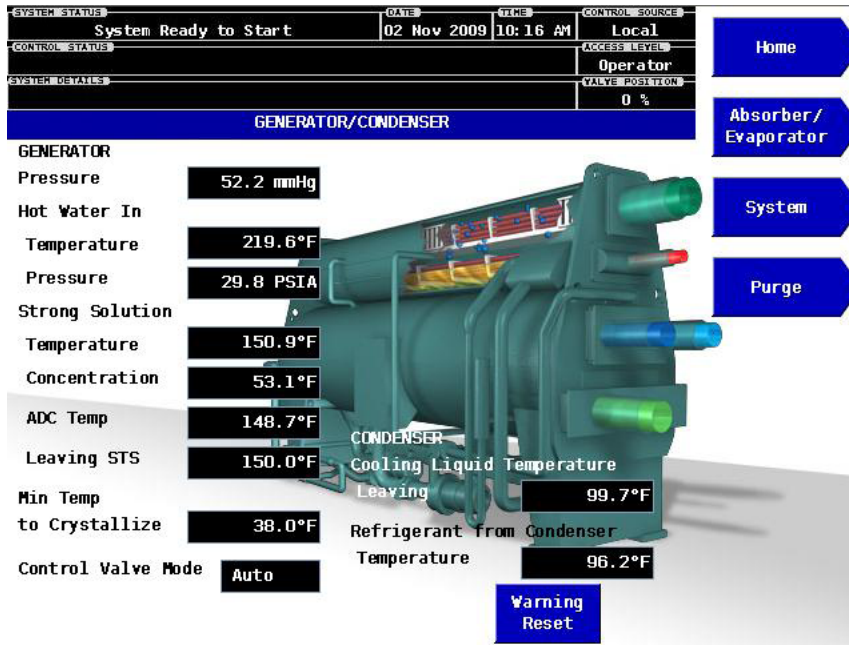

FIGURE 7 - GENERATOR / CONDENSER SCREEN

LD13814

GENERATOR / CONDENSER SCREEN

Overview

This screen displays a cutaway view of the chiller generator and condenser. Animation indicates whether the chiller is presently in a run condition.

Display Only

Generator - Pressure

Displays the pressure in the generator.

Steam in - Temperature and Pressure

Displays the steam inlet temperature and pressure when the unit is setup for steam.

Hot Water - Temperature and Pressure

Displays the hot water inlet temperature and pressure when the unit is setup for hot water.

Strong Solution

Displays the strong solution temperature, concentration, ADC temperature and strong solution temperature leaving the solution-to-solution heat exchanger.

Min temp to Crystallize

Displays the minimum temperature calculated to crystallize the strong solution.

Condenser

Displays the leaving cooling liquid temperature and refrigerant temperature from the Condenser.

Programmable

Load

Access Level Required: SERVICE

This key puts the control valve into manual mode and sends an open command to the control valve.

Unload

Access Level Required: SERVICE

This key puts the control valve into manual mode and sends a close command to the control valve.

Hold

Access Level Required: SERVICE

This key puts the control valve into manual mode and sends a hold command to the control valve.

Auto

Access Level Required: SERVICE

This key returns the control valve to automatic mode.

Warning Reset

Access Level Required: SERVICE

This soft key allows the technician to clear the warning message when in SERVICE mode.

Navigation

Home

Causes an instant return to the Home Screen.

Evaporator / Absorber

Causes an instant return to the Evaporator / Absorber Screen.

System

Causes an instant return to the System Screen.

Purge

Causes an instant return to the Purge Screen.

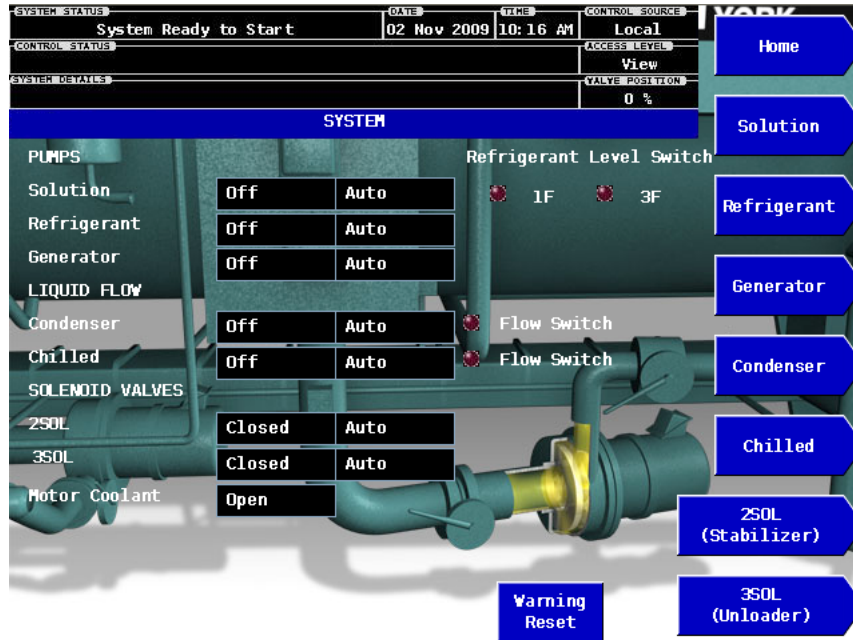

FIGURE 8 - SYSTEM SCREEN

LD13815

SYSTEM SCREEN

Overview

This screen gives an overview of system mechanical equipment status for both shells.

Display Only

Pumps

Displays the current On/Off state and Auto/Manual control of the Solution and Refrigerant Pumps (also Generator pump on units equipped with Franklin Pumps).

Liquid Flow

Displays the current On/Off state and Auto/Manual control of Condenser and Chilled Liquid Pump run contacts, and Condenser and Chilled Flow Switch status.

Solenoid Valves

Displays the current Closed/Open state and Auto/Manual control of the 2SOL and 3SOL Solenoid valves.

Refrigerant Level Switch

Displays the current state of the 1F and 3F refrigerant level switches.

Programmable

Solution

Access Level required: SERVICE

This key selects the solution pump for manipulation to Auto or Manual. To turn the pump "ON" or "OFF" use the soft keys located at the bottom of the display.

Refrigerant

Access Level required: SERVICE

This key selects the refrigerant pump for manipulation to Auto or Manual. To turn the pump "ON" or "OFF" use the soft keys located at the bottom of the display.

Generator

(Only shown on units configured for Franklin Pumps)

Access Level required: SERVICE

Condenser

Access Level required: SERVICE

This key selects the Condenser liquid pump run contacts for manipulation to Auto or Manual. To switch the Condenser run contacts "ON" (closed) or "OFF" (open) use the soft keys located at the bottom of the display.

Chilled

Access Level required: SERVICE

This key selects the Chilled liquid pump run contacts for manipulation to Auto or Manual. To switch the pump run contacts "ON" (closed) or "OFF" (open) use the soft keys located at the bottom of the display.

2SOL (Stabilizer Solenoid Valve)

Access Level required: SERVICE

This key selects 2SOL for manipulation to auto or manual. To "Open" or "Close" the stabilizer solenoid valve (2SOL) use the soft keys located at the bottom of the display.

3SOL (Unloader Solenoid Valve)

Access Level required: SERVICE

This key selects 3SOL for manipulation to auto or manual. To "Open" or "Close" the unloader solenoid valve (3SOL) use the soft keys located at the bottom of the display.

Manual Dilution

Access Level required: SERVICE

This soft key initiates a manual dilution cycle.

Navigation**Home**

Causes an instant return to the Home Screen.

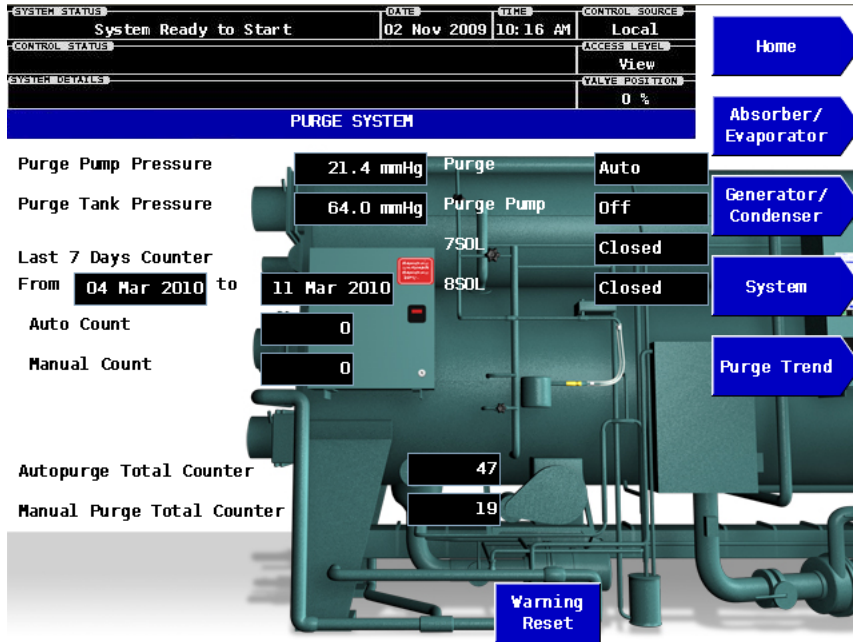

FIGURE 9 - PURGE SYSTEM SCREEN

LD13816

PURGE SYSTEM SCREEN

Overview

This screen gives an overview of parameters for the Purge System.

Display Only

Purge Pump Pressure

Displays the Purge Pump pressure, determined between the pump isolation ball valve and solenoid valves from PT3.

Purge Tank Pressure

Displays the Purge Tank pressure from PT4.

Last 7 Days Counter

Displays the from and to date for the 7 day purge counter.

Auto Count

Displays the number of Autopurges performed within the 7 day counter interval.

Manual Count

Displays the number of Manual purges performed within the 7 day counter interval.

Autopurge Total Counter

Displays the total number of Autopurges performed.

Manual Purge Total Counter

Displays the total number of Manual purges performed.

Purge

Displays the current "Auto" or "Manual" Purge system control mode.

Purge Pump

Displays the current "ON" or "OFF" state of the Purge pump.

7SOL

Displays the "Open" or "Closed" position of the purge tank solenoid valve (7SOL).

8SOL

Displays the "Open" or "Closed" position of the purge pump isolation ball valve (8SOL).

Programmable

Purge Pump

Access level required: SERVICE

This key selects the purge pump for manipulation, to turn it "ON" or "OFF" in "REPAIR" mode with the soft keys located at the bottom of the display.

7SOL (Purge Tank Isolation Valve)

Access Level required: SERVICE

This key selects the purge tank isolation valve for manipulation, to turn it "ON" or "OFF" in "REPAIR" mode with the soft keys located at the bottom of the display.

8SOL (Purge Pump Isolation Valve)

Access Level required: SERVICE

This key selects the purge pump isolation ball valve for manipulation, to turn it "ON" or "OFF" in "REPAIR" mode with the soft keys located at the bottom of the display.

Repair

Access Level required: OPERATOR

This key allows the purge pump, 7SOL, and 8SOL to be manually operated independently for troubleshooting or repair.

Manual/Auto

Access Level required: SERVICE

This key switches the purge system between Automatic and Manual control modes.

Maintenance

Access Level required: OPERATOR

Maintenance mode allows the operator to change the purge pump oil. In "Operator" mode a "Maintenance" key will be displayed at the bottom of the display. Pressing this key will change the pump to Maintenance mode. The "On/Open" and "Off/Close" keys can be manipulated to control the operation of the pump, while the remainder of the purge routine is disabled. The 7SOL and 8SOL valves will remain closed as long as the Maintenance mode is in effect. Pressing the "Manual/Auto" key will disable the Maintenance mode.

Navigation

Home

Causes an instant return to the Home Screen.

Evaporator / Absorber

Causes an instant return to the Evaporator / Absorber Screen.

Generator / Condenser

Causes an instant return to the Generator / Condenser Screen.

System

Causes an instant return to the System Screen.

Purge Trend

Causes instant access to the Purge Trend Screen.

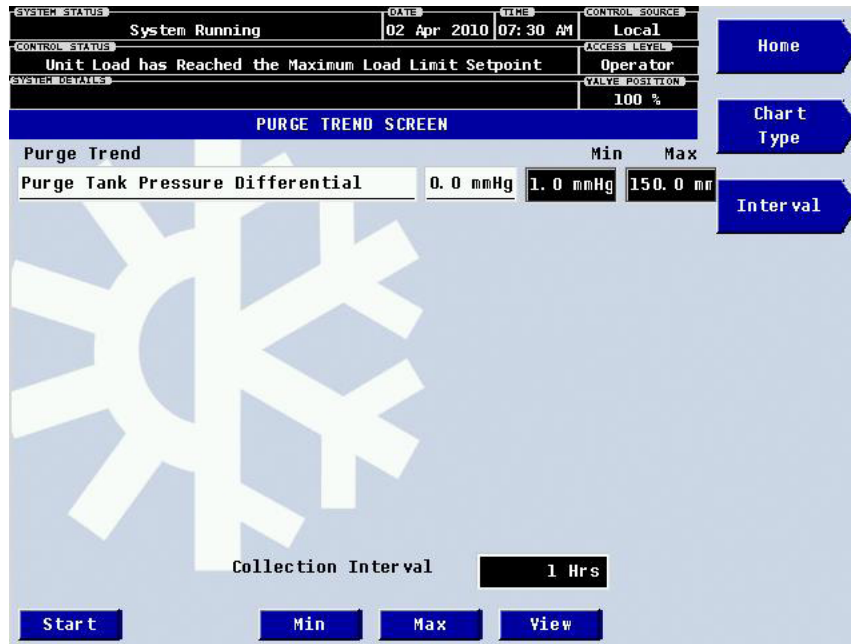

FIGURE 10 - PURGE TRENDS SCREEN

LD14068

PURGE TRENDS SCREEN

Overview

This screen gives a graphical chart tracking the Purge Tank pressure over a selected time period for troubleshooting and Purge Tank Pressure characteristics.

Display Only

Purge Tank Pressure Differential Chart

A graphical chart is generated to track the Purge tank Pressures over a 1 to 24 hour time in increments specified by the operator.

Programmable

Chart Type

Access Level required: OPERATOR

This key brings up a subscreen allowing the user to either select One Screen (default) or a Continuous Chart to represent the Purge Tank Pressure Differentials.

Interval

Access Level required: OPERATOR

This key brings up a subscreen allowing the user to select a 1 to 24 hour time interval (default 24 hour) value programmable by the operator to suit specific troubleshooting needs.

Start

Access Level required: OPERATOR

This key allows the user to begin the trending of the Purge Tank Pressure.

Stop

Access Level required: OPERATOR

This key allows the user to end the trending of the Purge Tank Pressure.

Min

Access Level required: OPERATOR

This key allows the user to define the minimum pressure value from -10 to 300 (default 0) on the Purge Tank Pressure Differential chart.

Max

Access Level required: OPERATOR

This key allows the user to define the maximum pressure value -10 to 300 (default 300) on the Purge Tank Pressure Differential chart.

Navigation

Home

Causes an instant return to the Home Screen.

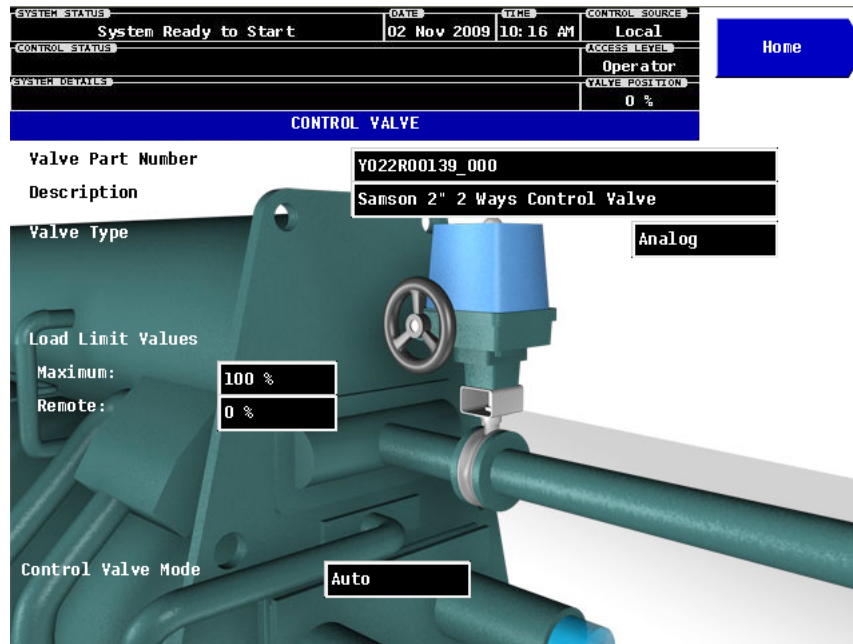

FIGURE 11 - CONTROL VALVE SCREEN

LD13817

CONTROL VALVE SCREEN

Overview

This screen gives an overview of setup parameters for the Control Valve.

Display Only

Valve Part Number

Displays the part number for the current control valve, as entered from the SALES ORDER screen, and the CONFIGURE screen in SERVICE access.

Description

Displays a brief description of the control valve.

Valve Type

Displays whether the valve is controlled 4-20mA (analog) or pulsed width modulation (digital) with position feedback.

Load Limit Values

Displays the current programmed max. load limit, and the present remote load limit value

Programmable

N/A

Navigation

Home

Causes an instant return to the Home Screen.

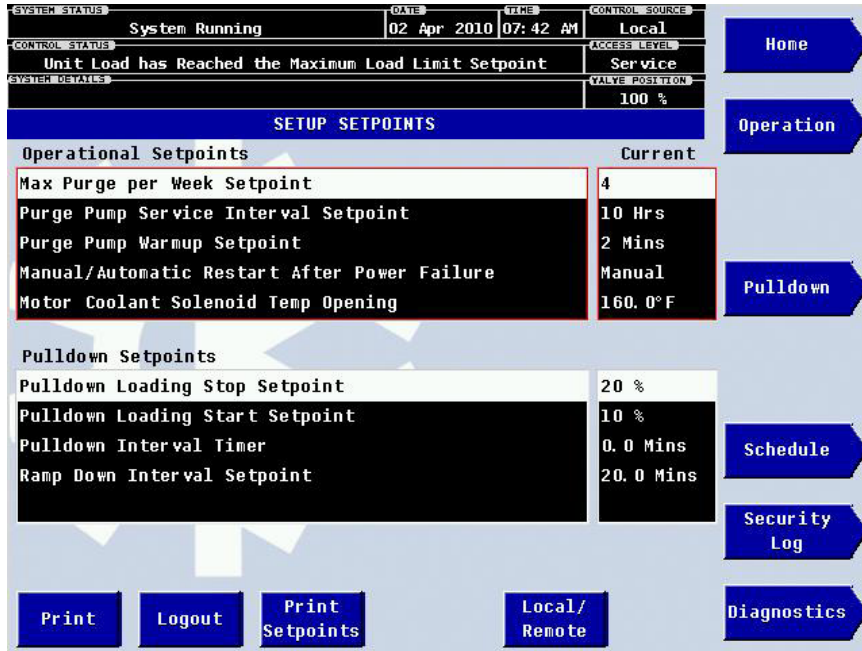

FIGURE 12 - SETPOINTS SCREEN

LD13818

SETPOINTS SCREEN

Overview

This screen provides a convenient location for programming the most common setpoints involved in the chiller control. This screen also serves as a gateway to the Diagnostics screen for service troubleshooting.

Display Only

Operational Setpoints

Displays the operational setpoints.

Pulldown Setpoints

Displays the pulldown setpoints.

Programmable

Operational Setpoints

Access Level required: SERVICE

Short Dilution Cycle Setpoint

Access Level required: SERVICE

This setpoint defines the criteria to perform a dilution cycle. When the value set to OFF is to keep constant dilution cycle length (6 minutes) and it does NOT use

the 2SOL valve to dilute the solution. When the value is set to ON considers the strong solution concentration to define the length of the dilution cycle and also opens the 2SOL valve to help shorten the dilution cycle. When this setpoint is set as OFF, the unit will perform a 6 minute dilution cycle. If this setpoint is set ON, the unit will perform a short dilution cycle, the dilution cycle depends on the strong solution concentration and uses the ranges provided in the following table.

Concentration	Pumps work During	2SOL Valve opens during
below 57%	N/A	N/A
57% - 59%	70 Seconds	50 Seconds
59% - 61%	110 Seconds	90 Seconds
61% - 63%	170 Seconds	150 Seconds
63% - 65%	200 Seconds	180 Seconds
above 65%	230 Seconds	210 Seconds

Range: ON / OFF

Default: ON

Automatic Restart After Power Failure

Access Level required: OPERATOR

This function defines how the unit will react to a power failure. If the setpoint is enabled and the unit was running, it will attempt to restart automatically. If the setpoint is disabled it will only restart upon a manual request.

Enabled (Auto Restart):

When the unit recovers power and the strong solution temperature is greater than crystallization limit temperature and the unit was running prior to the power failure: The unit is in a safe condition and restarts automatically.

Enabled (Auto Restart):

When the unit recovers the power and strong solution temperature is less than crystallization limit temperature, and the unit was running prior to the power failure: a cycling shutdown occurs, unit will start a dilution cycle and when it finishes (safe condition), the unit restarts automatically.

Disabled (Manual Restart):

When the strong solution temperature is greater than crystallization limit temperature and the unit was NOT in ready to start, in finished dilution cycle (safe condition), prior to power failure: Activates Safety Shutdown and waits for a Manual Reset.

If the unit was in ready to start, manual dilution cycle, in finished dilution cycle before the power failure, it does NOT matter if the setpoint is enabled or disabled. The unit is ready to start and shows message "POWER FAILURE OCCURED".

If the strong solution temperature is less than or equal to the crystallization limit temperature and the unit was NOT in ready to start, in finished dilution cycle, prior to the power failure, it does NOT matter if the setpoint is enabled or disabled. Activates safety shutdown.

Purge Pump Service Interval

Access Level required: OPERATOR

This setpoint warns the operator when the purge pump needs service. There is a purge pump operation time counter, and when it is greater than the preprogrammed purge pump service interval setpoint value, a warning appears in the control, this warning must be reset by the operator to be erased.

RANGE: 5 Hours - 100 Hours

DEFAULT: 10 Hours

Maximum Purge / Week

Access Level required: OPERATOR

This setpoint warns the operator regarding non condensable gases in the unit. When the automatic purge events counter is greater than the maximum allowed purge per week setpoint value, a warning appears in the control. This warning must be reset by the operator to clear and reset the counter.

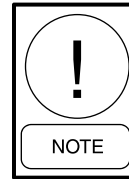

Critical setpoint default value should be used unless otherwise directed by Service.

RANGE: 2 purges/week - 6 purges/week

DEFAULT: 4 purges/week

Purge Warm-up

Access Level required: SERVICE

This setpoint defines how long the purge pump will be operating to warm up the purge oil before purging. When a purge process starts, the first step is to start the purge pump for the indicated time in the purge warm-up setpoint to heat the purge oil before opening the valves to the chiller. The purge process initiates after this setpoint time. If the warm up period is not enough to achieve operating temperature, the purge pump may have reduced ability to pull vacuum.

RANGE: 2 min. - 20 min.

DEFAULT: 2 min.

LCHLT Shutdown Offset

Access Level required: OPERATOR

This setpoint defines how far the LCHLT can be under the LCHLT setpoint before low LCHLT cycling shutdown occurs. The control activates a cycling shutdown when the LCHLT less than or equal to LCHLT setpoint - LCHLT Shutdown offset, and the unit recovers when the LCHLT is greater than LCHLT setpoint + 2. This setpoint is automatically overridden to NOT allow LCHLT less than 38°F (3.3°C). This value should be set to match thermal inertia of the site to avoid short-cycling the chiller.

RANGE: 2°F - 4°F (-16°C - -15.5°C)

DEFAULT: 3°F (-16.1°C)

RT10 Strong Soln from STS Temp Offset*Access Level required:* SERVICE

This offset is to compensate slight error of the RT10 sensor. The considered temperature for strong solution from the Heat Exchanger will be read from RT10 + RT10 Strong Soln from STS Temp Offset. If this value is NOT correct, the considered strong solution temperature from the heat exchanger will be wrong. This temperature is used by the panel to determine the need for dilution during cycling shutdowns.

RANGE: -5°F to 5°F (-20°C to -15°C)

DEFAULT: 0°F

RT9 Condensed Refrigerant Temp Offset*Access Level required:* SERVICE

This offset is to compensate slight error of the RT9 sensor. The considered temperature for condensed refrigerant will be read from RT9 + RT9 Condensed Refrigerant Temp Offset. If this value is NOT correct, the considered condensed refrigerant temperature will be wrong. This temperature is used by the panel to determine strong solution concentration for control. In the worst cases an inaccurate value can contribute to crystallization.

RANGE: -5°F to 5°F (-20°C to -15°C)

DEFAULT: 0°F (-17.7°C)

RT3 Strong Soln from Gen Temp Offset*Access Level required:* SERVICE

This offset is to compensate slight error of the RT3 sensor. The considered temperature for strong solution from generator will be read from RT3 + RT3 Strong Soln from Gen Temp Offset. If this value is NOT correct, the considered strong solution temperature will be wrong. This temperature is used by the panel to determine strong solution concentration for control. In the worst cases an inaccurate value can contribute to crystallization.

RANGE: -5°F to 5°F (-20°C to -15°C)

DEFAULT: 0°F (-17.7°C)

Refrigerant Pump Shutoff Delay*Access Level required:* SERVICE

This setpoint determines the time delay between detection of insufficient refrigerant level and the control center initiating a shutdown of the Buffalo refrigerant pump. When the refrigerant level has decreased below the level that allows refrigerant level switch 3F to open, and it remains open continuously for the duration of the programmed timer, the refrigerant pump will be shutdown after this setpoint time delay has elapsed. This setpoint

is used in conjunction with the REFRIGERANT PUMP STARTUP DELAY setpoint to limit pump cycling.

RANGE: 1 second - 45 seconds

DEFAULT: 30 seconds

Refrigerant Pump Start-up Delay*Access Level required:* SERVICE

This setpoint determines the delay between detection of sufficient refrigerant level and the control center initiating a start of the Buffalo refrigerant pump. When the refrigerant level has increased to a level that allows refrigerant level switch 1F to close, and it remains closed continuously for the duration of this timer, the refrigerant pump will be started after this setpoint time delay has elapsed. This setpoint is used in conjunction with the REFRIGERANT PUMP SHUTDOWN DELAY setpoint to limit pump cycling. This setpoint timer is disabled at the instant of unit shutdown. This is to allow the refrigerant pump to start at the beginning of the dilution cycle.

RANGE: 1 second - 900 seconds

DEFAULT: 120 seconds

Chiller Refrigerant Level Shutdown Delay*Access Level requirement:* SERVICE

This setpoint is a timer that determines the amount of time the unit is allowed to operate without the refrigerant pump running when the unit is equipped with Buffalo pumps. If the refrigerant pump is not started before the timer elapses, a safety shutdown is performed and "DAY-TIME-REFRIGERANT PUMP LEVEL SWITCH 3F FAILURE" is displayed.

RANGE: 20 minutes - 60 minutes

DEFAULT: 30 minutes

Motor Coolant Solenoid Open Temp

(Units equipped with Franklin Pumps Only)

Access Level requirement: SERVICE

The motor coolant solenoid valve (1SOL) is normally energized (opened) when the strong solution temperature is greater than 160°F (71.1°C) and de-energized (closed) when it is less than 150°F (65.5°C). Units operating at lower heat source temperature require a lower temperature threshold for energizing (opening) the motor coolant solenoid valve (1SOL). The "close" threshold is fixed at (programmed open threshold minus 10°F (-12.2°C)). The default value should be used unless directed otherwise by YORK/Johnson Controls Service.

Schedule Setpoints

N/A

Pulldown Setpoints

Ramp Down Interval Timer (Soft Shutdown)

Access Level required: OPERATOR

This setpoint defines the time interval for the control to use to ramp the steam/hot water control valve from full open to the minimum load setpoint, prior to shutdown of the chiller upon a soft shutdown command. This time is referenced to a 100% open valve position, so actual ramp down time at other valve positions is a proportion of this maximum interval. Actual ramp down time is determined by the following: Ramp Down Interval Timer x (Valve position at onset - Low Unload Limit setpoint) / (100 - Low Unload Setpoint). Once the valve position reaches the minimum load setpoint, the unit is shutdown from cooling sequence. This setpoint should be set as required to avoid shocks in the site steam supply system.

RANGE: 0 min. - 60 min.

DEFAULT: 0 min.

Pull Down Interval Timer

Access Level required: OPERATOR

This setpoint defines the duration of the pulldown process. Pulldown is executed on initial startup. The pulldown process saves energy and relieves the chiller startup transient on the site heat supply by limiting the steam/hot water control valve opening to a controlled linear ramp when the machine is starting. The steam/hot water control valve maximum opening position is limited by the prevailing pulldown demand limit position. This position is an increasing ramp from the Pulldown Loading Start Setpoint position to the Pulldown Loading Stop Setpoint position over the Pulldown Interval Time.

RANGE: 0 min. - 255 min.

DEFAULT: 0 min.

Pulldown Loading Start Setpoint

Access Level required: OPERATOR

This setpoint defines the control valve open position limit at the beginning of the pulldown process.

RANGE: 10% - 30%

DEFAULT: 10%

Pulldown Loading Stop Setpoint

Access Level required: OPERATOR

This setpoint defines the control valve open position limit at the end of the pulldown process.

RANGE: 20% - 100%

DEFAULT: 10%

Current Valve Opening = [(Pulldown loading stop setpoint - Pulldown loading start setpoint)*(Time elapsed of the pull down process / Pulldown interval timer)] + Pulldown loading start setpoint.

Print

Access Level Required: VIEW

Generates **Setpoints** print report.

NAVIGATION

Home

Causes an instant return to the Home Screen.

Operation

Selects operational setpoints for viewing.

Schedule

Selects Schedule setpoints for viewing.

Pulldown

Selects Pulldown setpoints for viewing.

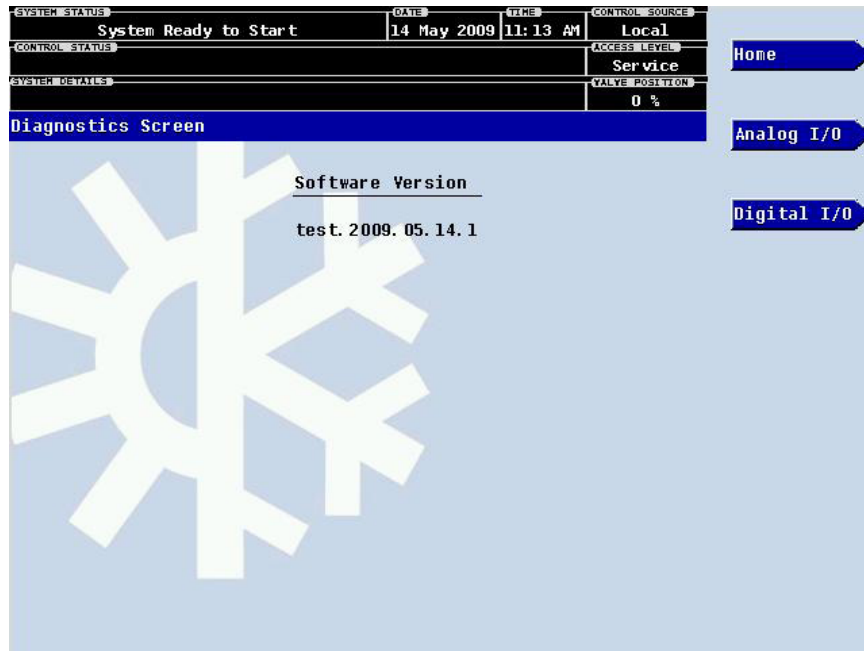

FIGURE 13 - DIAGNOSTICS SCREEN

LD14069

DIAGNOSTICS SCREEN

Overview

This screen shows details of the Software Version the Absorption chiller is currently running.

Display Only

Software Version

States the Software Version the OptiView Control center is currently running.

Programmable

N/A

Navigation

Home

Causes an instant return to the Home Screen.

Analog I/O

Service access level only.

Digital I/O

Service access level only.

SYSTEM STATUS		DATE	TIME	CONTROL SOURCE			
System Ready to Start		02 Nov 2009	10:16 AM	Local			
CONTROL STATUS		ACCESS LEVEL		VALVE POSITION			
		Operator		0 %			
SYSTEM DETAILS							
SALES ORDER							
JCI	Model		YIA_ST_14F3_46_C_5_B				
	York Order		XX-XXX-XXXXXX				
Design Data	Serial Number		XXXXXXXXXX-XX				
	EWT	LWT	Flow	PD	Pass	DWP	Flui
	°F	°F	(GPM)	FT		PSIG	%
Evap	54	44	1000	25	2	150	Water
Con/Ab	85	98	2000	32	2/1	150	Water
HW Gen	N/A	N/A	N/A	N/A	N/A	N/A	N/A
Cooling Capacity	1000		Tons	Voltage		460/3	
Steam Cons	7000		Lbs/hr	KW		30	
Steam Pressure	10		PSIG @ Gen		Johnson Controls North America		
Steam Pressure	15		PSIG @ Valve		1-800-861-1001		
Print							

FIGURE 14 - SALES ORDER SCREEN

LD13819

SALES ORDER SCREEN

Overview

This screen shows details of the sales order parameters. These values should never be changed or entered by anyone other than a qualified Service Technician. The remainder of the values are entered at the YORK Factory during the manufacturing of the chiller.

Display Only

Model

Factory defined model number of the chiller system.

YORK Order

Factory defined order number under which the chiller was sold.

Chiller Serial Number

Factory defined serial number for the chiller system.

Panel Serial Number

Factory defined serial number for the micropanel.

Evaporator, Condenser/Absorber, and Generator Design Load Information

Factory defined description of the condenser, evaporator, and generator configuration at time of shipment.

System Information

Factory defined conditions for which the chiller was originally rated and sold.

Programmable

Print

Access Level Required: VIEW

This generates a listing of the Sales Order data.

NAVIGATION

Home

Causes an instant return to the Home Screen.

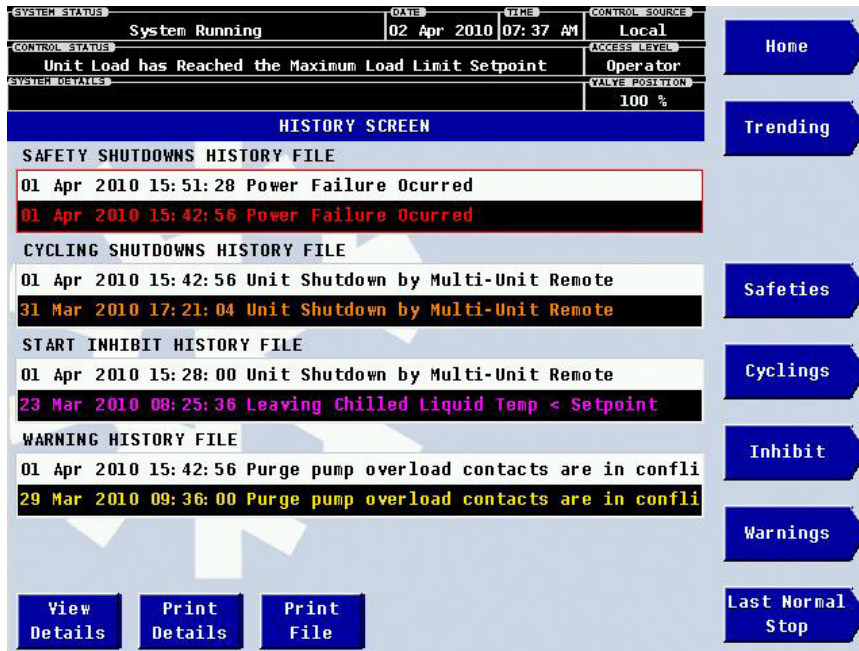

FIGURE 15 - HISTORY SCREEN

LD13820

HISTORY SCREEN

Overview

This screen allows the user to browse through the system faults. In order to get a more thorough reporting of the system conditions at the time of the recorded shutdown, view and print details buttons are available.

The user may use the soft keys provided to access the Safety Shutdowns, Cycling Shutdowns, Start Inhibits, and Warning Histories. The view details button will show the operating data at the time of shutdown. The **Print Details** button can be used to generate a hard-copy report of the parameter values at the time of the shutdown. The print file button will generate a print of the parameter values for all of the faults in the selected file grouping.

Display Only

Safety Shutdowns History File

This window displays the date and time and the description of the Safety Shutdowns.

Cycling Shutdowns History File

This window displays the date and time and the description of the Cycling Shutdowns while the system was running.

Start Inhibit History File

This window displays the date and time and a description of the condition that would not allow the unit to be started.

Warning History File

This window displays the history of any warnings that have been encountered.

View Details

Access Level Required: VIEW

This generates a report listing the status of the chiller parameters at the time of the selected shutdowns.

Print Details

Access Level Required: VIEW

This generates a hard copy printed report listing the status of the chiller parameters at the time of the selected shutdowns. For additional details refer to the Printers Section of this manual.

Print File

Access Level Required: VIEW

This generates a savable electronic report via hyperterminal listing the status of the chiller parameters at the time of the selected shutdowns. For additional details refer to the Printers Section of this manual.

PROGRAMMABLE

N/A

NAVIGATION**Home**

Causes an instant return to the Home Screen.

Trending

This key causes a instant return to the Trending Screen allowing the user to view trending data on selected chiller parameters.

Safeties

This soft key activates the Safeties Shutdown History details to be accessed.

Cyclings

This soft key activates the Cycling Shutdowns History File to be accessed.

Inhibit

This soft key activates the Start Inhibit History File to be accessed.

Warnings

This soft key activates the Warnings History File to be accessed.

Last Normal Stop

This soft key activates a pop-up window with the parameter values at the time of the last normal chiller stop command.

While this window is displayed, the print details button will generate a hardcopy report of the data. The keypad "X" key will exit the pop-up window.

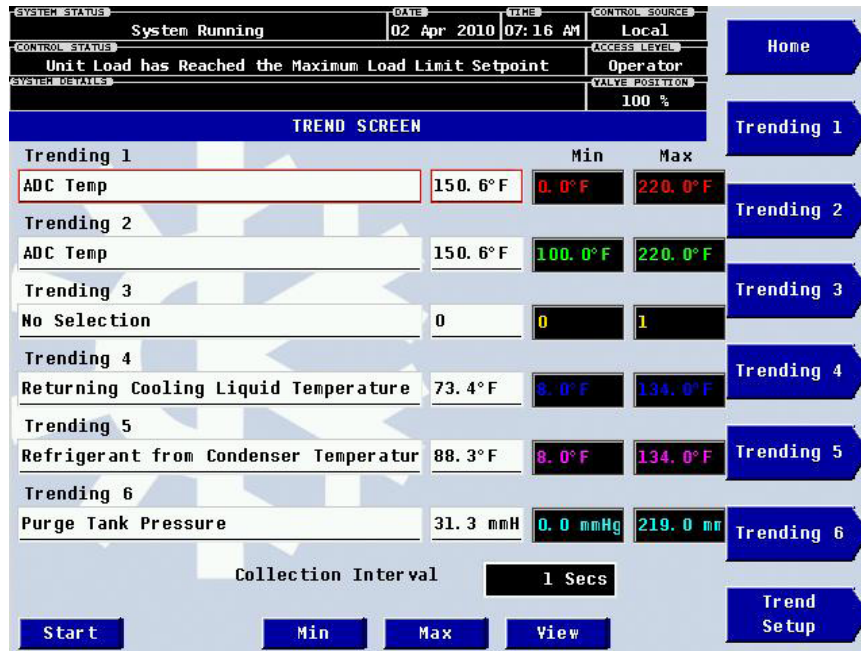

FIGURE 16 - TREND SCREEN

LD14070

TREND SCREEN

Overview

This screen allows the user to select up to 6 different trends for tracking system operating conditions.

Display Only

Trending 1 - Trending 6

This screen displays the operating condition(s) selected to be tracked.

Programmable

Trending 1 - Trending 6

Access Level required: OPERATOR

This screen allows the operator to select 6 different operating conditions to be tracked by selecting the "Trending 1" - "Trending 6" key(s). Upon selecting "Trending 1" - "Trending 6" allows the operator to select an operating condition from a pre-defined drop-down list. The selectable trending conditions are as follows:

- Purge Tank Pressure
- Purge Pump Pressure
- Refrigerant from Condenser
- Leaving STS
- Strong Solution Concentration
- Strong Solution Temperature
- Min. Temperature to Crystallize

- Steam Pressure
- Steam in Temperature
- Generature Pressure
- Refrigerant Temperature
- Total Operating Hours
- Leaving Cooling Liquid Temperature
- Returning Cooling Liquid Temperature
- Leaving Chilled Liquid Temperature
- Returning Chilled Liquid Temperature
- Valve Postion

Trend Setup

Access Level required: OPERATOR

This key brings up a subscreen that allows the operator to select the Collection Interval and Chart Type for the trending chart.

Start

Access Level required: OPERATOR

This key allows the operator to START the unit trending data collection.

Stop

Access Level required: OPERATOR

This key allows the operator to STOP the unit trending data collection.

Min

Access Level required: OPERATOR

This key allows the operator to to set the minimum value on the trending chart.

Max

Access Level required: OPERATOR

This key allows the operator to set the maximum value trending chart.

Navigation**Home**

Causes an instant return to the Home Screen.

Trend Setup

Causes an instant return to the Trend Setup Screen.

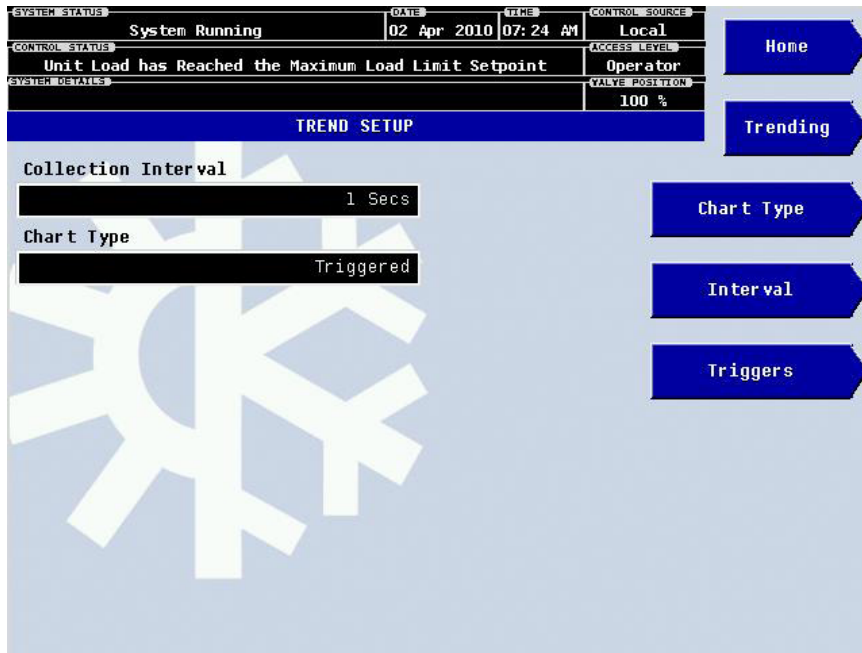

FIGURE 17 - TREND SETUP SCREEN

LD14071

TREND SETUP SCREEN

Overview

This screen allows the operator to configure the trending Data Chart.

Display Only

N/A

Programmable

Collection Interval

Access Level Required: OPERATOR

This key allows the Operator to select the interval at which the requested data is collected.

Chart Type

Access Level required: OPERATOR

This key allows the Operator to select "One Chart" or "Continuous" for representing the trending data collected.

Navigation

Home

Causes an instant return to the Home Screen.

Trending

Causes an instant return to the Trending Screen.

Triggers

Causes an instant return to the Triggers Screen.

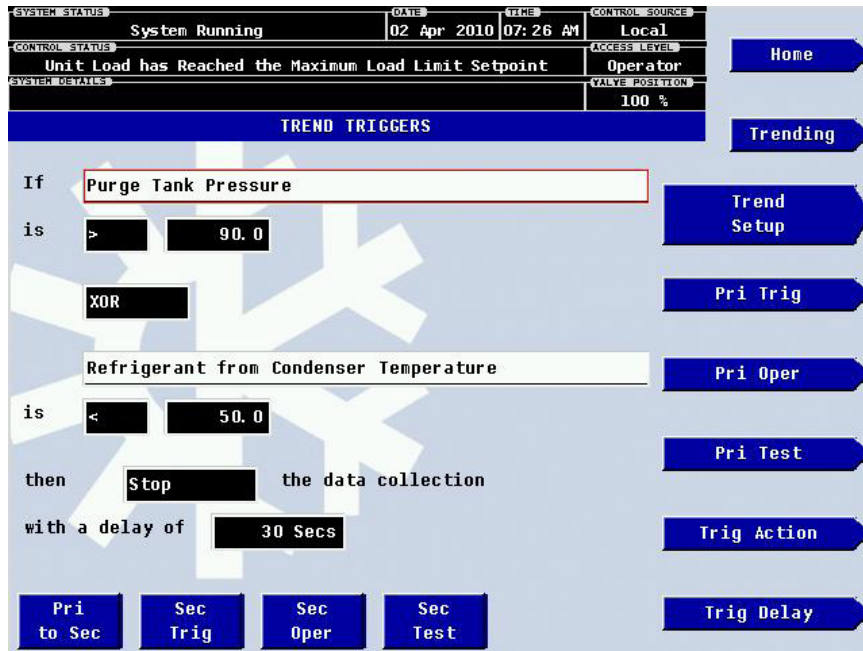

FIGURE 18 - TRIGGERS SCREEN

LD14072

TRIGGERS SCREEN

Trend Setup Screen Overview

This screen allows the Operator to select desired data collection start/stop triggers. The trend data collection can be set to start or stop based upon the status of up to two selected triggers.

The Triggers can consist of digital events or analog parameters compared to thresholds. The Triggers can be used individually or in combination.

The parameter selected as the primary trigger is compared to a value selected as the primary test, using the Primary Operator as a comparator. If it is evaluated as true, then the data collection is started or stopped (after any selected trigger delay) per the selected trigger Action.

A secondary trigger can be evaluated with the primary trigger to start/stop data collection. The Primary to Secondary Operator is used to define the trigger combinations required to be true to start/stop data collection. The Secondary Trigger is setup and evaluated the same as the Primary Trigger. Entry fields are as follows:

If
 Is

Is
 Then the Data Collection
 With a delay of

After the desired Triggers are set, the "START" key on the TREND Screen must be manually pressed before the triggers will be evaluated. While waiting for the triggers to start or stop data collection, a status message is displayed in the upper right corner of the TREND Screen describing the pending action.

Display Only

N/A

Programmable

Pri Trig

Access Level required: OPERATOR

This key allows the Operator to select the first parameter to be evaluated. Selection is made from a pre-defined list.

Pri Oper

Access Level required: OPERATOR

This key allows the Operator to select the comparator for the Primary Trigger's relationship to the Primary Test. If the Primary Trigger is an analog value, selections are: <, <=, =, =>, >. If the Primary Trigger is a digital event, selections are: Equal To, Not Equal To.

Pri Test

Access Level required: OPERATOR

This key allows the Operator to select the value or condition that the Primary Trigger is compared to. Selection ranges from the Primary Trigger minimum value to the Primary Trigger maximum value.

Trig Action

Access Level required: OPERATOR

This key allows the Operator to select whether the trend data collection will Start or Stop when the Trigger comparisons are true. If set to Start, data collection will stop after one screen of data is collected.

Trig Delay

Allows the data collection start or stop to be delayed after the Triggers evaluate as true. The delay is selectable from 1 to 1,600 seconds (26 min.). Display is in minutes and seconds. The delay timer begins when the triggers evaluate as true. If the Trigger Action is set to START, data collection will begin after the triggers evaluate as true and the delay timer has elapsed. If the Trigger Action is set to STOP, data collection will stop after the Triggers evaluate as true and the delay timer has elapsed.

Pri to Sec

This key allows the Operator to select whether the Primary Trigger, Secondary Trigger or both have to be true in order to start or stop data collection. Selections are AND, OR, XOR and None.

- If NONE is selected, the Secondary Trigger is disabled.

Data collection will start/stop (as selected with Trigger Action) when:

- If AND selected: Both Primary AND Secondary are true.
- If OR selected: Either Primary OR Secondary (or both) are true.
- If XOR selected: Either Primary OR Secondary (but not both) are true.

Sec Trig

This key allows the Operator to select the second parameter to be evaluated. Selection is made from the Slot Numbers listing on the Trend Common Slots Screen or the Master Slot Numbers List in this book. Setting this slot number to zero disables the Secondary Trigger.

Sec Oper

This key allows the Operator to select the comparator for the Secondary Trigger's relationship to the Secondary Test. If the Secondary trigger is an Analog value, selections are: <, <=, =, =>, >. If the Secondary Trigger is a digital event, selections are: Equal To, Not Equal To.

Sec Test

This key allows the Operator to select the value or condition that the Secondary Trigger is compared to. Selection ranges from the Secondary Trigger minimum to the Secondary Trigger maximum.

Navigation

Home

Causes an instant return to the Home Screen.

Trending

Causes an instant return to the Trending Screen.

Trend Setup

Causes an instant return to the Trend Setup Screen.

DISPLAY MESSAGES

The Status Bar of the Display contains a Status Line and, beneath it a Details Line. The Status Line contains a message describing the operating state of the chiller; whether it is stopped, running, starting or shutting down. The Details Line displays Warning, Cycling, Safety, Start Inhibit and other messages that provide further details of the Status Bar messages. The Status Messages listed below are displayed on the Status Line. All other messages are displayed on the Details Line.

To aid in the meaning of the message, messages are displayed in different colors as follows:

- Normal Operation messages - Green
- Warning messages - Yellow
- Cycling Shutdown messages - Orange
- Safety Shutdown messages - Red

Status Messages

System Ready to Start

The chiller is shut down but will start upon receipt of a Local or Remote start signal.

System Starting

A chiller start has been initiated and the control is performing pre-run checks.

System Running

The chiller is running under the condition described in the Details Line of the Status Bar.

Cycling Shutdown – Autostart

The chiller is shut down on a CYCLING shutdown. The cause of the shutdown is still in effect and is displayed on the Details line of the Status Bar. The chiller will automatically restart when the CYCLING condition clears.

Safety Shutdown – Reset to Restart

The chiller is shutdown on a SAFETY shutdown. The cause of the shutdown is still in effect and is displayed on the Details line of the Status Bar. The chiller can be started after the Safety condition clears and the Operator is required to press the WARNING RESET key in OPERATOR or SERVICE access to clear the warning.

System Start Inhibited

The chiller is prevented from being started due to the reason displayed on the Details Line of the Status bar.

Run Messages

ADC in progress - load Limit to 50%

The auto-decrystallization process is triggered when the temperature sensed by RT2 is greater than 160°F (71.1°C).

This process sets the valve opening to 50% to decrease the concentration in the solution, and opens 2SOL valve 2 minutes every 10 minutes. If the 3F level switch opens the auto-decrystallization process stops and starts a limited auto-decrystallization process. The unit verifies the temperature in RT2 every 10 minutes, if it is less than 150°F (65.5°C), the control assumes that the unit has been decrystallized and returns to normal operating conditions.

Cooling Start Sequence initiated

A chiller start has been initiated and the control is performing pre-run checks.

Dilution Cycle is in progress

The system is in dilution. The chiller pumps will run and require chilled liquid and condenser liquid flow with the control valve closed until the dilution timer expires. The Stabilizer Valve (2SOL) will open as required.

High Concentration Control in effect

The system is running in LOCAL or REMOTE mode. Loading is limited by the strong solution concentration compared to the solution temperature leaving the solution-to-solution heat exchanger (RT10). Concentration is calculated using strong solution temperature (RT3) and refrigerant from the condenser temperature (RT9).

Leaving Chilled Liquid Temperature Control in effect

The system is running in LOCAL or REMOTE mode. The loading and unloading is being automatically controlled by the leaving chilled liquid temperature setpoint.

Limited Dilution Cycle is in progress

A limited dilution cycle is performed when the control calls for dilution, and a dilution cycle can NOT be performed, due to loss of power for the chiller pumps. It only applies when backup power is supplied for the solution pump.

Manual Dilution Cycle is in progress

A dilution cycle was initiated manually in SERVICE access and is in progress. It lasts 6 minutes or until terminated manually.

Manual Operation Control in effect

The Control Valve is in Manual operation, in SERVICE access. The valve may be in "LOAD", "UNLOAD", or "HOLD" command.

A limited dilution cycle starts only the solution pump, and it can last up to 4 hours. If the fault condition clears, the control reverts to normal dilution.

Primary Limited ADC in progress - Load set to 50%

Applicable only to units equipped with buffalo pumps.

The unit is running and performing a "Primary Limited Automatic Decrystallization Cycle". This variation of the standard Automatic Decrystallization Cycle (ADC) is performed if the refrigerant pump is not running when a standard ADC is initiated or is turned-off during a standard ADC.

Limited ADC have two phases: Primary and Secondary (see below). The Primary Limited ADC is the same as Standard ADC except it is performed for only 10 minutes and the stabilizer refrigerant solenoid valve (2SOL) is not energized (opened) during the first two minutes of the cycle, as would be done in a Standard ADC. If the refrigerant pump starts before the "Primary Limited ADC" terminates, (level switches 1F and 3F close), a normal ADC is performed. Otherwise, when 10 minutes have elapsed and the "Primary Limited ADC" terminates, normal chiller operation continues, unless the ADC temperature (RT2) is greater than 150°F (65.6°C) when it terminates, then the "Secondary Limited ADC" (see below) is initiated.

Secondary Limited ADC in progress

Applicable only to units equipped with Buffalo pumps. The unit is running and performing a "Secondary Limited Automatic Decrystallization Cycle". The secondary limited ADC is performed for 15 minutes. It is initiated at the completion of a "Primary ADC" (see preceding) if the ADC temperature is greater than 150°F (65.6°C) when the primary ADC terminates.

While the "Secondary ADC" is in effect, the stabilizer refrigerant solenoid valve (2SOL) is not energized (opened) and the steam/hot water valve is driven to the closed (0%) position. If the refrigerant pump starts before the "Secondary Limited ADC" terminates (level switches 1F and 3F close), a standard ADC is performed and the unit continues to run.

Unit is unable to perform a Limited Dilution Cycle

The control is calling for a limited dilution cycle and it is unable to be performed.

Unit Load has reached the Maximum Load Limit Setpoint

The system is running in LOCAL or REMOTE operating mode and the steam or hot water valve position has reached and is being limited to the "Max Allowed Loading" setpoint value that has been programmed by the service technician. During unit commissioning, it is sometimes necessary to temporarily limit the load to some value less than 100% because of local or unit conditions. Programming of this function should only be performed by a qualified service technician.

Unit Load has reached the Remote Load Limit Setpoint

The system is running in REMOTE mode and the unit loading is being inhibited by the remote load limit command from a remote device. The load value that is in effect can be viewed from the Valve Screen.

The load limit value is 100% to 10% but is limited further by the local max. and min. load setpoints.

Unit Load is controlled by Pulldown Demand Limit

The system is running in LOCAL or REMOTE mode. The loading is being inhibited by the programmed pulldown demand limit.

Unit Load is controlled by Rampdown Limit

A soft shutdown has been initiated and the system is closing the steam/hot water control valve according to the Rampdown Interval Timer setpoint for shutdown.

Unit load is set to 30%

The Steam/Hot Water Control Valve is driven to 30% open due to Generator High Pressure warning.

Start Inhibit Messages

Auxiliary Safety Shutdown

When "Auxiliary Safety Shutdown" contacts connected between , I/O Board TB4-1 and TB4-31 are open. The message clears when the "Auxiliary Safety Shutdown" contact closes.

Generator Hi-press analog PT1 > 672 mmHg

This message is displayed when generator shell pressure is greater than or equal to 672mmHg. The message clears when Generator shell pressure is less than 672mmHg.

HW Valve loaded > 10% close to < 9% to restart

When the Hot Water Control Valve position is greater than 10% and the unit is OFF. This message clears when the Hot Water Control Valve position is less than 9%.

Leaving Chilled Liquid Temp < Setpoint

When the LCHLT is less than LCHLT setpoint. this message clears when LCHLT is greater than LCHLT setpoint.

Low Refrigerant Temp Analog RT8 < 33°F (.56°C)

The unit is inhibited from starting because the refrigerant temperature is less than or equal to 33°F (.56°C). The message clears when the refrigerant temperature is greater than 33°F (.56°C).

Low Refrigerant Temp in Evap RT8 < 35.5°F (1.9°C)

This message indicates the refrigerant temperature decreased to 35.5°F (1.9°C). The unit will be inhibited from further loading (the load signal will be allowed to decrease or remain at it's present level, but will NOT be allowed to increase) until the refrigerant temperature increases to 36.0°F (2.2°C). The reset threshold is 36.0°F (2.2°C).

Unit Shutdown by Multiunit Remote

This message is displayed when the "Multi-unit sequence" contact connected between I/O Board TB4-1 and TB4-9 opens. The message clears when the "Multi-unit Sequence" contacts close.

Steam Valve Loaded > 10% close to < 9% to restart

This message is displayed when the Steam Control Valve position is greater than 10% and the unit is OFF. This message clears when the Steam Control Valve position is less than 9%.

Unit in Standby until power supply recovers

This message occurs during power failure, when an emergency power is used. The Cycling Shutdown Contacts close, Shut-off Valve closes, and 6SOL Valve (if applicable) closes, and all pumps stop. Clears when normal power is restored.

Unit shutdown by Remote Device

The unit is ready to start and the "Remote / Local Cycling" contact connected between I/O board TB4-1 and TB4-13 opens. This message clears when the "Remote / Local Cycling" contacts close.

Warning Messages

Autopurge Failure - Purge Tank Pressure has not decreased

This message occurs when the purge tank pressure (PT4) has not decreased in 6 seconds when there is an autopurge in process. The unit will close 7SOL and 8SOL, change the purge mode to MANUAL, stop the purge pump after 65 seconds, and close the alarm contacts.

Recovery Condition

- Pressing the WARNING RESET key in SERVICE access will open the alarm contacts.

Excess Purging in the Last 7 Days – see Setpoint-

The purge counter has counted a number of purges beyond the Maximum Purge/Week setpoint. The chiller alarm contacts close.

Recovery Condition

- Pressing the WARNING RESET key at any moment opens the alarm contacts.
- Pressing the WARNING RESET key in SERVICE access clears the message.

Faulty Strong Solution Temp Sensor RT3

This message occurs when the strong solution temperature is less than or equal to 91°F (32.7°C) and the unit has been running more than 30 minutes. When this condition occurs the unit closes the alarm contacts.

Recovery Condition

- Strong solution temperature is less than 91°F (32.7°C); releases this warning, it is required to press the WARNING RESET key in OPERATOR or SERVICE access to clear the warning.
- Pressing the WARNING RESET key at any moment opens the alarm contacts.

Generator High Pressure > 517mmHg - Load set to 30%-

This message occurs when the generator shell pressure is greater than or equal to 517mmHg (10PSIA).

When this warning occurs the unit limits the control valve opening to 30% and closes the alarm contacts.

Recovery Condition

- Generator shell pressure is less than or equal to 310 mmHg (6PSIA), enables control valve opening greater than 30%, it is required to press the WARNING RESET key in OPERATOR or SERVICE access to clear the warning.
- Pressing the WARNING RESET key at any moment will open the alarm contacts.

High Hot Water Supply Temp RT7 > XXX.X°F (XXX°C)

This message occurs when the unit hot water supply temperature is greater than or equal to 250°F (121.1°C), and the unit is configured as hot water low temp. energy supply. When the units hot water supply temperature is greater than or equal to 266°F (130°C), and the unit is configured as hot water high temperature energy supply.

Recovery Condition

- Hot water supply temperature is less than 249.5°F (120.8°C), unit is hot water low temp; releases this warning but it is required to press the WARNING RESET key in OPERATOR or SERVICE access to clear the message.

- Hot water supply temperature is less than 266°F (130°C), unit is hot water high temp; releases the warning, but it is required to press the WARNING RESET key in OPERATOR or SERVICE access to clear the message.
- Pressing the WARNING RESET key at any moment opens the alarm contacts.

High Steam supply Press PT2 > 32 PSIA (220.6KPA)

This message occurs when the units steam supply pressure is greater than or equal to 32PSIA (220.6kPa). When this condition occurs the unit closes the alarm contacts.

Recovery Conditions

- Steam supply pressure is less than 31 PSIA (220.6kPa); releases this warning, it is required to press the WARNING RESET key in OPERATOR or SERVICE access to clear the message.
- Pressing the WARNING RESET key at any moment will open the alarm contacts.

High Steam Supply Temp RT7 > XXX.X°F (XXX°C)

This message occurs when the unit Steam supply temperature is greater than or equal to 285°F (140.5°C), and the unit is configured as steam low temp energy supply, or when the units Steam supply temperature is greater than or equal to 337°F (169.4°C), and the unit is steam high temp energy supply.

Recovery Conditions

- Steam supply temperature is less than 284°F (140°C), unit is steam low temp; releases this warning but is required to press the WARNING RESET key in OPERATOR or SERVICE access to clear the message.
- Steam supply temperature is less than 336°F (168.8°C), unit is steam high temp; releases this warning but it is required to press the WARNING RESET key in OPERATOR or SERVICE access to clear the message.
- Pressing the WARNING RESET key at any moment opens the alarm contacts.

Low Ref Temp in Evap RT8 < 34.0°F (1.1°C) - Soln Pump is off

The evaporator refrigerant temperature is less than or equal to 34°F (1.1°C).

When this warning occurs the unit stops the solution pump, opens 2SOL if the refrigerant pump is running, inhibits load command for valve opening, and closes alarm contacts.

Recovery Condition

- Refrigerant temperature is greater than 34°F (1.1°C); changes warning message to "LOW REFRIGERANT TEMPERATURE RT8 is less than 35.5°F (1.9°C)", this message allows the solution pump operation.
- Refrigerant temperature is greater than 36°F (2.2°C); it releases the warning, closes 2SOL, enables the solution pump operation and LOAD command for the control valve. It is required to press the WARNING RESET key when in OPERATOR or SERVICE access to clear this message.
- Pressing the WARNING RESET key at any moment opens the alarm contacts.

Low Refrigerant Temperature in Evap RT8 < 35.5°F (1.9°C)

The evaporator refrigerant temperature is less than or equal to 35.5°F (1.9°C).

When this condition occurs the unit opens 2SOL if the refrigerant pump is running, inhibits load command for valve opening, and will close the alarm contacts.

Recovery Condition

- Refrigerant temperature is greater than 36°F (2.2°C); it releases this warning, closes 2SOL, enables the solution pump operation and LOAD command for the control valve. It is required to press the WARNING RESET key when in OPERATOR or SERVICE access to clear this message.
- Pressing the WARNING RESET key at any moment opens the alarm contacts.

Possible Crystallization RT2 > 160°F (71.1°C)

Temperature on the automatic decrystallization line (RT2) exceeded 160 °F (71.1°C) during operation. Automatic decrystallization process started.

Recovery Condition

- Temperature on the automatic decrystallization line (RT2) decreased below 150 °F (65°C) when the ADC process timed out.

Purge Failure; PT3 > 15mmHg - Check Purge Pump

This message occurs when the unit is attempting to perform a manual or auto purge, the purge pump is running and the purge pump pressure does not decrease less than 15mmHg within 2 minutes from 8SOL receiving an open command. The unit will close 8SOL, stop the purge pump, after 65 seconds change the pump mode to MANUAL, and close the alarm contacts. The unit performs a safety check corresponding to the current operation state.

Recovery Conditions

- Press the WARNING RESET key in OPERATOR or SERVICE access to clear the warning.
- Pressing the WARNING RESET key at any moment opens the alarm contacts.

Purge Pump failure - manually close VP2 & VP4

This message occurs when the purge pump pressure at PT3 is greater than 100mmHg and the purge pump is running. The unit will close 7SOL and 8SOL if open, turn OFF the purge pump after 65 seconds, change the purge mode to MANUAL if in AUTO, and close the alarm contacts.

Recovery Condition

- Purge pump pressure is less than 100mmHg; it releases this warning but it is required to press the RESET WARNING key in OPERATOR or SERVICE access to clear the warning.

Purge Pump Overload Contacts are in conflict

This message occurs when purge pump overload contacts change from closed to open and the pump is not running. The unit will change purge mode to MANUAL if in AUTO, and close the alarm contacts.

Recovery Condition

- Purge pump overload contacts close; releases this warning but it is required to press WARNING RESET key in OPERATOR or SERVICE access to clear the warning.

Purge Pump Overloads Opened

This message occurs when the purge pump overload contacts changed from closed to open and the pump was running.

When this condition occurs the unit closes the alarm contacts, closes 7SOL and 8SOL if open, sets the purge pump to OFF, stops the purge pump operation counter, and changes the purge mode to MANUAL if it is in AUTO.

Recovery Conditions

- Purge pump overload contacts close releases this warning and enables change to AUTO purge mode, it is required to press the WARNING RESET key in OPERATOR or SERVICE access to clear the warning.
- Pressing the WARNING RESET key at any moment opens the alarm contacts.

Purge Pump Service recommended

This message occurs when the purge pump run hours counter is greater than the Purge pump service interval setpoint. It is required to press the WARNING RESET key in OPERATOR or SERVICE access to clear the message.

Recovery Condition

- Pressing the WARNING RESET key at any moment will acknowledge the warning and open the alarm contacts.

Purge Tank Pressure is > 100mmHg

This message occurs when the unit purge tank pressure (PT4) is greater than or equal to 100mmHgA. The unit will close 7SOL and 8SOL, change the purge mode to MANUAL, stop the purge pump after 65 seconds, and close the alarm contacts.

Recovery Condition

- Purge tank pressure is less than 100mmHg; it releases this warning but is required to press the WARNING RESET key in OPERATOR or SERVICE access to clear the warning.

Purge Transducer PT4 out of range

This message occurs when the purge tank pressure is less than or equal to 0mmHgA, when this occurs the alarm contacts will close.

Recovery Condition

- Purge tank pressure is greater than 0mmHgA; it releases this warning, it is required to press the WARNING REST key in OPERATOR or SERVICE access to clear the warning.

Refrigerant from Condenser RT9 or Shell Pressure PT1 conflict

This message occurs when the condensed refrigerant temperature sensed by RT9 does not correspond to the condensing pressure sensed by PT1.

Short dilution cycle and strong solution concentration control is disabled and dilution occurs upon low LCHLT cycling shutdown regardless of strong solution temperature.

Recovery Condition

- Condensed refrigerant temperature corresponds to Condensing pressure; releases this warning but it is required to press WARNING RESET key in OPERATOR or SERVICE access to clear the warning. Short dilution (if originally selected) is enabled and strong solution control logic restarted.

Refrigerant Level Switch Conflict - CHK 1F & 3F

This message occurs when 3F is open at least for "Refrigerant pump shutdown delay" setpoint, 1F is closed at least the by the indicated by "Refrigerant pump start up delay" setpoint and the unit is equipped with Bufalo pumps.

This warning does NOT modify the state of the machine.

Recovery Condition

- 3F closes at least for "Refrigerant pump shutdown delay setpoint", releases this warning but it is required to press the WARNING RESET key in OPERATOR or SERVICE access to clear the warning.

Refrigerant Pump Overload Contacts are in conflict

This shutdown occurs when the refrigerant pump overload contacts open when the refrigerant pump is OFF. If the unit is NOT running, the unit will be set in a stand by safety shutdown condition. If the unit is running, it will start a limited dilution cycle.

Recovery Condition

- The operator should address the problem and place the unit switch in the STOP/RESET position.

Solution Pump Overload Contacts are in conflict

This shutdown occurs when the solution pump overload contacts open when the solution pump is off. The unit will be set in a stand by safety shutdown condition.

Recovery Condition

- The operator should solve the problem, and place the unit switch to the STOP/RESET position.

High Steam Supply Pressure PT2 > 32 psia (220.6kpa)

The unit is not running and the valve is closed for 10 minutes steam line pressure is above 20 psia. This is an indication that live steam may be inadvertently available to a shutdown unit. This message resides until pressure is below 32 psia.

Recovery Condition

- Steam line pressure is less than 20 PSIA releases this warning but is required to press the RESET WARNING key in SERVICE access to clear the warning.

8SOL failure; PT3 > 100mmhg - manually close VP2 & VP4

This message occurs when purge pump pressure at PT3 is greater than 100mmHg and the purge pump is not running. The unit will close 7SOL and 8SOL if opened, start the purge pump, change the purge mode to MANUAL if in AUTO, and close the alarm contacts.

Recovery Condition

- Purge pump pressure is less than 100mmHg; releases this warning but is required to press the RESET WARNING key in OPERATOR or SERVICE access to clear the warning.

Routine Shutdown Messages**Local Stop**

A local shutdown command has been received as Soft Shutdown or by placing the Keypad Start-Run-Stop/Reset Switch in the Stop (O) position.

Remote Stop

A shutdown command has been received from a remote device. Remote Stop commands can be received in Digital Remote mode via I/O Board TB4-7/8 or in ISN (Integrated Systems Network) Remote mode via the MicroGateway serial communications. If the chiller is running when this occurs, the steam or hot water valve is driven fully closed prior to shutting down the chiller.

Cycling Shutdown Messages**Daily Schedule Programmed Stop**

The unit will perform a dilution cycle and execute a cycling shutdown if the unit was running when there is a daily stop time that matches the current machine time.

Recovery Condition

- The unit is started manually by the operator or there is a daily schedule start time that matches the current machine time and the main switch is not in the stop position.

Emergency Power Source Activated

The unit will perform a cycling shutdown when there is a power failure and there is an emergency power supply. The unit will execute a limited dilution cycle and block any other activity in the machine if the unit was running or in a dilution cycle. The unit will stop any manual pumps and valves operation.

Recovery Condition

- The power is recovered, the unit will restart if it was running before the power failure or the unit activates a safety shutdown "RT3 LOW TEMP AFTER POWER FAILURE - CHK CRYST" if the unit was not running.

Low Leaving Chilled Liquid Temperature

The unit executes a cycling shutdown when LCHLT is less than (LCHLT setpoint - LCHLT offset setpoint). If the LOCAL entered LCHLT setpoint was changed in the past 30 minutes, this cycling shutdown is NOT initiated unless the LCHLT is less than both the resulting new LCHLT setpoint and the previous LCHLT setpoint by the offset value. If multiple LCHLT setpoint changes have been made within 5 minutes of each other, the latest one is considered a single change for this control. The unit stops all pumps except the chilled liquid pump, closes the shut-off valve and the control valve.

Recovery Condition

- LCHLT is greater than or equal to LCHLT setpoint + 2.

Power Failure Occurred

The unit was running and the panel power and was off, the unit is configured to auto start after a power failure.

Recovery Condition

- The unit will restart automatically.

Unit Shutdown by Remote Device

The unit is ready to start and the "Remote / Local Cycling" contact connected between I/O board TB4-1 and TB4-13 opens. This message clears when the "Remote / Local Cycling" contacts close.

Recovery Condition

- "Remote / Local cycling" contact opens, the machine restarts automatically if there is not any other active cycling or safety shutdown.

Unit Shutdown by Multiunit Remote

This message is displayed when the "Multi-unit sequence" contact connected between I/O Board TB4-1 and TB4-9 opens. The message clears when the "Multi-unit Sequence" contacts close.

Recovery Condition

- "Multi-unit cycling" contacts close, the machine restarts automatically if there is not any other active cycling or safety shutdown.

Safety Shutdown Messages**Auxiliary Safety Shutdown**

The auxiliary safety shutdown contacts connected between I/O board TB4-1 and TB4-31 are open. If the chiller was in RUN status, the chiller initiates a dilution cycle.

Recovery Condition

- The auxiliary safety shutdown contacts are closed and the unit switch is taken to STOP/RESET position. The chiller continues dilution if it was in progress and becomes ready to start.

Chilled Liquid Flow Switch Opened

The chilled water flow switch has been opened continuously for the safety duration. If the chiller was in RUN status, the switch must be opened continuously for 2 seconds and then the chiller initiates limited dilution. If the chilled liquid pump was commanded to run in manual mode from the control panel and the unit was not in RUN status, the switch must be opened continuously for 30 seconds.

Recovery Conditions

- If the chiller was in RUN status at the time of the event, and limited dilution has timed out (4 hours), when the unit switch is taken to STOP/RESET position the chiller becomes ready to start.
- If the chiller was in RUN status at the time of the event and the unit switch is taken to STOP/RESET position before limited dilution has timed out (4 hours) the unit initiates dilution then the chiller becomes ready to start.
- If the chiller was not in RUN status at the time of the event, when the switch contacts close or call for manual pump operation is ceased and the unit switch is placed to STOP/RESET position the chiller becomes ready to start.

Cond Flow Switch closed during Limited Dilution

This shutdown occurs when the condenser water flow switch has been closed continuously for 30 seconds when the unit is performing a limited dilution cycle.

Recovery Condition

- The operator should review and resolve the problem, place control in the STOP/RESET position, and run manual dilution if necessary.

Condenser Liquid Flow Switch Opened

The condenser liquid flow switch has been opened continuously for 30 seconds. If the chiller was in RUN status, the chiller initiates limited dilution. If the condenser liquid pump was commanded to run in manual mode from the control panel and the unit was not in RUN status, the chiller remains in standby.

Recovery Conditions

- If the chiller was in RUN status at the time of the event, and limited dilution has timed out (4 hours), when the unit switch is taken to STOP/RESET position the chiller becomes ready to start.
- If the chiller was in RUN status at the time of the event and the unit switch is taken to STOP/RESET position before limited dilution has timed out (4 hours) unit initiates dilution then the chiller becomes ready to start.
- If the chiller was not in RUN status at the time of the event, when the switch contacts close or call for manual pump operation is ceased and the unit switch is placed to STOP/RESET position the chiller becomes ready to start.

Dilution Cycle Interrupted-Chilled Water Off

The chilled liquid flow switch has not closed during the first 30 seconds of normal dilution or opened for 2 continuous seconds during dilution. Limited dilution initiates.

Recovery Condition

- After the chiller condition is assessed and the problem corrected, the unit can be restarted. To restart the unit, press the UNIT switch to the STOP/RESET position, then press the WARNING RESET key, then initiate a start.

Dilution Cycle Interrupted-Cond Water Off

The condenser liquid flow switch has not closed during the first 30 seconds of normal dilution or opened for 30 continuous seconds during dilution. Limited dilution initiates.

Recovery Condition

- After the chiller condition is assessed and the problem corrected, the unit can be restarted. To restart the unit, press the UNIT switch to the STOP/RESET position, then press the WARNING RESET key, then initiate a start.

Dilution Cycle Interrupted - Switch 3F Opened

This shutdown occurs when 3F is open at least for "Chiller Refrigerant level shutdown delay setpoint" when the unit is performing a dilution cycle (only applicable to unit equipped with Buffalo Pumps). The unit will start a limited dilution cycle after the refrigerant pump shutoff delay expires.

Recovery Condition

- When the unit switch is placed in the STOP/RESET position, it attempts a dilution cycle ready to start.

Generator Hi-Press Analog PT1 > 672 MmHg

The generator shell pressure sensed at PT1 is greater than or equal to 672 mmHG. If the chiller was in RUN status, the chiller initiates a dilution cycle.

Recovery Conditions

- If the chiller was in RUN status at the time of the event, then when the shell pressure at PT1 is less than 672 mmHg and the unit switch is taken to STOP/RESET position the chiller continues dilution if it was in progress or becomes ready to start.
- If the chiller was not in RUN status at the time of the event, when the shell pressure at PT1 is less than 672 mmHg and the unit switch is placed to STOP/RESET position the chiller becomes ready to start.

Gen Hi-Temp Analog Switch RT3 > 330°F (166°C)

The strong solution temperature from the generator sensed at RT3 is greater than or equal to 330°F (165.6°C). If the chiller was in RUN status, the chiller initiates a dilution cycle.

Recovery Conditions

- If the chiller was in RUN status at the time of the event, then when the strong solution temperature from the generator sensed at RT3 is less than or equal to 329°F (165°C) and the unit switch is taken to STOP/RESET position the chiller continues dilution if it was in progress or becomes ready to start.
- If the chiller was not in RUN status at the time of the event, when the strong solution temperature from the generator sensed at RT3 is greater than or equal to 329°F (165°C) and the unit switch is placed to STOP/RESET position the chiller becomes ready to start.

Generator Hi-Press Digital Switch HP1 Opened

The generator high pressure digital safety switch opened (Shutdown = 710 mmHg Abs). If the chiller was in RUN status, the chiller initiates a dilution cycle.

Recovery Conditions

- If the chiller was in RUN status at the time of the event, then when the digital safety contacts close (Reset = 40 mmHg Abs) and the unit switch is taken to STOP/RESET position the chiller continues dilution if it was in progress or becomes ready to start.
- If the chiller was not in RUN status at the time of the event, when the digital safety contacts close (reset = 40 mmHg Abs) and the unit switch is placed to STOP/RESET position the chiller becomes ready to start.

Gen Hi-Temp Digital Switch HT1 Opened – Man Reset

The generator high temperature digital safety switch opened (Shutdown = 337°F/169°C). If the chiller was in RUN status, the chiller initiates a dilution cycle.

Recovery Conditions

- If the chiller was in RUN status at the time of the event, then when the digital safety contacts close (Reset = 333°F/167°C) and the unit switch is taken to STOP/RESET position the chiller continues dilution if it was in progress or becomes ready to start.
- If the chiller was not in RUN status at the time of the event, when the digital safety contacts close (Reset = 333°F/167°C) and the unit switch is placed to STOP/RESET position the chiller becomes ready to start.

High Concentration in Strong Solution

This shutdown occurs when the strong solution concentration is greater than or equal to strong solution concentration safety shutdown limit (66%). When this occurs the unit will perform a dilution cycle.

Recovery Condition

- Strong solution concentration is less than strong solution concentration safety shutdown limit and the unit switch is placed to the STOP/RESET position, the unit becomes "READY TO START" at restart.

High Hot Water Supply Temp RT7 > %XXX.XX°F

The unit is hot water fed and the hot water temperature less than or equal to 255°F (123°C) and the generator configuration is for low temp, or the unit is hot water fed and the hot water temperature is greater than or equal to 270°F (132°C) and the generator configuration is high temp. The unit will perform a dilution cycle.

Recovery Conditions

- Hot Water temperature is less than 254°F (123°C) when the generator configuration is low temp and the unit switch is placed in the STOP/RESET position.
- Hot Water temperature is less than 269°F (131°C) when the generator configuration is high temp and the unit switch is placed in the STOP/RESET position.

High Steam Supply Press PT2 > 35psia (241.3kpa)

This safety shutdown occurs when the steam supply pressure is greater than or equal to 35PSIA (241.3KPA), the unit will perform a dilution cycle.

Recovery Condition

- Steam supply pressure is greater than or equal to 31PSIA and the unit switch is placed to the STOP/RESET position; unit becomes "READY TO START".

High Steam Supply Temp RT7 > XXX.XX°F

The unit is steam fed and the steam temperature \geq 290°F (143°C) and the generator configuration is for low temp, or the unit is steam fed and the steam temperature is \geq 340°F (171°C) and the generator configuration is high temp. The unit will perform a dilution cycle.

Recovery Conditions

- Steam temperature is less than 289°F (142°C) when the generator configuration is low temp and the unit switch is placed in the STOP/RESET position.
- Steam temperature is less than 339°F (170°C) when the generator configuration is high temp and the unit switch is placed in the STOP/RESET position.

Low Refrigerant Temp Analog RT8 < 33°F (0.56°C)

The refrigerant temperature sensed at RT8 is less than or equal to 33°F (.56°C). If the chiller was in RUN status, the chiller will close valves and stop all pumps except the chilled water pump run contacts.

Recovery Conditions

- If the chiller was in RUN status at the time of the event, then when the refrigerant temperature at RT8 is greater than or equal to 37°F (2.7°C) and the unit switch is taken to STOP/RESET position the chiller initiates dilution then becomes ready to start.
- If the chiller was not in RUN status at the time of the event, when the refrigerant temperature at RT8 is greater than or equal to 37°F (2.7°C) and the unit switch is placed to STOP/RESET position the chiller becomes ready to start.

Low Refrigerant Temp Digital LRT Opened

The digital low refrigerant temperature switch opened (Shutdown = 33°F/6°C). If the chiller was in RUN status, the chiller will close valves and stop all pumps except the chilled water pump run contacts.

Recovery Conditions

- If the chiller was in RUN status at the time of the event, then when the refrigerant temperature switch closes (Reset = 37°F/2.7°C) and the unit switch is taken to STOP/RESET position the chiller initiates dilution then becomes ready to start.
- If the chiller was not in RUN status at the time of the event, when the refrigerant temperature switch closes (Reset = 37°F/2.7°C) and the unit switch is placed to STOP/RESET position the chiller becomes ready to start.

Low Motor Coolant Level - MCFL Switch Opened

This safety shutdown occurs when the unit is equipped with Franklin pumps has MCFL switch opened.

Recovery Condition

- Motor coolant flow switch closes and the unit switch is placed in the STOP/RESET position. If the unit was running before the failure, it performs a dilution cycle when the motor coolant flow switch closes.

Manual Restart After Power is Restored

The chiller has recovered the power supply and the restart after power failure setpoint is set to MANUAL. The chiller initiates a dilution cycle.

Recovery Condition

- The unit switch is taken to STOP/RESET position. The chiller continues dilution if it was in progress or becomes ready to start.

MCFL Switch Opened, LDC Interrupted - Chk Cryst

This shutdown occurs when the motor coolant float switch opens when the unit is performing a limited dilution cycle (only applicable to units equipped with Franklin pumps).

Ref Pump Overload Twice - Chk for Cryst

This safety shutdown occurs when the refrigerant pump overload contacts recover the second time since the unit was started. The unit is set in a stand by safety shutdown condition.

Recovery Condition

- After it has been determined that crystallization has not occurred, the unit can be restarted. To restart the unit, press the UNIT switch to the STOP/RESET position, then press the WARNING RESET key in SERVICE access and then initiate a start.

Refrigerant Pump Overloads Opened

Refrigerant pump motor protector overload or thermal switch contacts opened and the pump was running. If the chiller was in RUN status, the chiller initiates limited dilution.

Recovery Conditions

- If the chiller was in RUN status at the time of the event and the event was the first such event since last start: When the overload contacts close, the unit performs dilution and then if the unit switch is taken to STOP/RESET position the chiller becomes ready to start.
- If the event was not the first solution pump overload event since last start, the control activates the safety shutdown “REF PUMP OVERLOAD TWICE-CHK FOR CRYST”.
- If the chiller was not in RUN status at the time of the event, when the overload contacts close, and the unit switch is placed to STOP/RESET position the chiller becomes ready to start.

Refrigerant Pump Level Switch 3F Failure

The chiller shutdown because the refrigerant pump has been stopped for the duration of the Chiller Refrigerant Level Shutdown Delay setpoint. The chiller initiates limited dilution.

Recovery Condition

- If the chiller is in limited dilution when the switch contacts close the unit initiates dilution and then if the unit switch is taken to STOP/RESET position the chiller becomes ready to start. If limited dilution has stopped, and the unit switch is taken to STOP/RESET position the chiller becomes ready to start.

RT3 Low Temp while MCFL Shutdown - Chk Cryst

This safety shutdown occurs when the unit is equipped with Franklin pumps has MCFL switch opened, the refrigerant pump does not have coolant to cool the motors, the unit can not operate and immediately stops all the pumps.

Recovery Condition

- If the chiller was not diluted at the moment that MCFS opened, there is a risk of crystallization if the unit continues with MCFL opened and the strong solution temperature.

Secondary ADC Finished – Chk for Cryst

Secondary automatic decrystallization completed its 15 minute time period without the temperature on the automatic decrystallization line (RT2) decreased below 150°F (65°C). Dilution initiates.

Recovery Condition

After it has been determined that crystallization has not occurred, the unit can be restarted. To restart the unit, press the UNIT switch to the STOP/RESET position, then press the WARNING RESET key in SERVICE access and then initiate a start.

RT3 Low Temp after Power Failure - Chk Cryst

This shutdown occurs when power failed during run status and the strong solution temperature at RT3 or RT10 is less than or equal to crystallization limit temperature when the unit recovers the power.

Recovery Condition

- After it has been determined that crystallization has not occurred, the unit can be restarted. To restart the unit, press the UNIT switch to the STOP/RESET position, then press the WARNING RESET key in SERVICE access and then initiate a start.

Soln Low Temp & Low Ref Temp Shtdwn – Chk Cryst

Strong solution temperature from the generator (RT3) or solution heat exchanger (RT10) decreased below the calculated crystallization temperature during the time the chiller was in safety shutdown from low refrigerant temperature detected at RT8, LOW REFRIGERANT TEMP ANALOG RT8 is less than 33°F (0.56°C).

Recovery Condition

- After it has been determined that crystallization has not occurred, the unit can be restarted. To restart the unit, press the UNIT switch to the STOP/RESET position, then press the WARNING RESET key in SERVICE access and then initiate a start.

RT3 Low Temp while MCFL Shutdown - Chk Cryst

The unit (equipped w/ Franklin Pumps only) is in stand by due to a " LOW MOTOR COOLANT LEVEL - MCFL SWITCH OPENED" safety shutdown and the strong solution temperature at RT3 or RT10 is less than crystallization limit temperature.

Recovery Condition

- After it has been determined that crystallization has not occurred, the unit can be restarted. To restart the unit, press the UNIT switch to the STOP/RESET position, then press the WARNING RESET key in SERVICE access and then initiate a start.

Solution Pump Overload - Chk Crystallization

The unit executed a safety shutdown because a solution pump motor protector overload or thermal switch opened and the strong solution temperature is less than Crystallization limit temperature or while performing an ADC. The unit will be set in stand-by until the problem is addressed and the unit is reset.

Recovery Condition

- After it has been determined that crystallization has not occurred, the unit can be restarted. To restart unit, press UNIT Switch to the STOP/RESET position, then press the WARNING RESET key in SERVICE access and then initiate a start.

Solution Pump Overloads Opened

Solution pump motor protector overload or thermal switch contacts opened and the pump was running.

Recovery Conditions

- If the chiller was in RUN status at the time of the event and the event was the first such event since last start: When the overload contacts close, the unit performs dilution and then if the unit switch is taken to STOP/RESET position the chiller becomes ready to start.
- If the event was not the first solution pump overload event since last start, the control activates the safety shutdown “SOLUTION PUMPOVERLOAD TWICE- CHK FOR CRYST”.
- If the chiller was not in RUN status at the time of the event, when the overload contacts close, and the unit switch is placed to STOP/RESET position the chiller becomes ready to start.

Solution Pump Overload Twice - Chk for Cryst

This safety shutdown occurs when the solution pump overload contacts recover the second time since the unit was started. The unit is set in stand by safety shutdown condition.

Recovery Condition

- After it has been determined that crystallization has not occurred, the unit can be restarted. To restart the unit, press the UNIT switch to the STOP/RESET position, then press the WARNING RESET key in SERVICE access and then initiate a start.

Equipment Status Messages**Chilled Liquid Pump has been stopped after 2 hours of Operation**

The chilled liquid pump was manually started with the chiller not running and the 2 hour run limiting timer has expired. The pump run contacts are opened automatically by the control. This message resides until the unit switch is taken to RUN or the WARNING/RESET key pressed in OPERATOR or SERVICE access.

Condenser Pump has been stopped after 2 hours of Operation

The condenser pump was manually started with the chiller not running and the 2 hour run limiting timer has expired. The pump run contacts are opened automatically by the control. This message resides until the unit switch is taken to RUN or the WARNING/RESET key pressed in OPERATOR or SERVICE access.

Control Valve Calibration in Progress

Applies to unit set up for digital control valve. This message displays while the control center is performing a valve calibration procedure.

Control Valve Calibration is Successful

Applies to unit set up for digital control valve. This message displays for 60 seconds after the completion of a control valve calibration procedure.

Disabled Warnings have been Erased

Status messages that were able to clear have been cleared using the WARNING/RESET key. This message resides for 60 seconds after the reset command is issued.

Generator Pump has been Stopped after 2 hours of Operation

The generator (Franklin pump units) pump was manually started with the chiller not running and the 2 hour run limiting timer has expired. The pump is stopped automatically by the control. This message resides until the unit switch is taken to RUN or the WARNING/RESET key pressed in OPERATOR or SERVICE access.

Manual Dilution Prohibited

Manual dilution process not be started at this time due to equipment or status conflict. This message resides for 60 seconds after the failed manual dilution command is issued.

Manual Purge Started

A manual purge was initiated by an operator from the panel. This message resides for 60 seconds after the command is issued.

Pumps Manual Control Prohibited

Control for one of the pumps can not be switched to manual because the unit is running in automatic control. This message resides for 60 seconds after the failed control command is issued.

Purge Pump Off

The purge process has completed and the purge pump is de-energized. This message resides for 60 seconds after the pump command is issued.

Purge Pump Valve Closing

The purge process has completed and the autopurge ball valve is given a closed command (de-energized). This message resides for 60 seconds after the valve command is issued.

Refrigerant Pump has been Stopped after 2h of Operation

The refrigerant pump was manually started with the chiller not running and the 2 hour run limiting timer has expired. The pump is stopped automatically by the control. This message resides until the unit switch is taken to RUN or the WARNING/RESET key pressed in OPERATOR or SERVICE access.

Refrigerant Pump is Off and 2SOL is Open

2SOL has been opened manually with the refrigerant pump off. This is an unusual condition. This message resides until a close command is issued to 2 SOL.

Reset Prohibited at this Moment

The chiller can not be reset at this time due to equipment or status conflict. This message resides for 60 seconds after the failed reset command is issued.

Service Access Level is needed to Reset the Unit

The chiller can not be reset at this time because SERVICE level access is required for this function due to the nature of the standing fault. This message resides for 60 seconds after the failed reset command is issued.

Solution Pump has been Stopped after 2 Hours of Operation

The solution pump was manually started with the chiller not running and the 2 hour run limiting timer has expired. The pump is stopped automatically by the control. This message resides until the unit switch is taken to RUN or the WARNING/RESET key pressed in OPERATOR or SERVICE access.

Solution Pump is Off and 3SOL is Open

3SOL has been opened manually with the solution pump off. This is an unusual condition. This message resides until a close command is issued to 3 SOL.

Start Prohibited at this Moment

The chiller can not be started at this time due to equipment or status conflict. This message resides for 60 seconds after the failed start command is issued.

Valve Calibration Prohibited

Control valve calibration process not be started at this time due to equipment or status conflict. This message resides for 60 seconds after the failed calibration command is issued.

3SOL and 2SOL Manual Control Prohibited

Control for the stabilizer or unloader solenoid valve can not be switched to manual because the unit is waiting for a SERVICE level reset or in limited dilution. This message resides for 60 seconds after the failed control command is issued.

SECTION 3 PRINTERS



SEIKO DPU-414

FIGURE 19 – PRINTERS

A printer or laptop can be connected to the Control Center's Microboard to print the following reports. The screen from which each report can be generated is listed in parenthesis.

- **Status** - Present system parameters
- **Setpoints** - Present programmed values of all setpoints
- **Sales Order** - Information on Sales Order Screen (Printer, Sales Order)
- **History** - System parameters at the time of the last normal stop, last fault while running and last 10 faults, whether running or not (Printer, History)

The printer can be permanently connected to the Control Center or connected as required to produce a report.

The following figures are examples of the different print reports.

- FIGURE 20 - Operating Data
- FIGURE 21 - Last Normal Stop
- FIGURE 22 - Sales Order
- FIGURE 23 - History
- FIGURE 24 - Purge Trend
- FIGURE 25 - Setpoints

PRINTERS

The following Printer can be used. **Printer must be equipped with an RS-232 Serial interface.**

- **Seiko –**

Printer: DPU414-30B

Dimensions: 6.3 in. wide x 6.7 in. deep

Paper: 4.4 in. wide

Type: Thermal

Power Supply: PW4007I (required)

Battery Pak (Ni-Mh): BP4005

Thermal paper: SS112-025A

Purchase: Jaco Electronics (formally Repron acquired by Jaco)

13710 Repron Blvd

Tampa, Florida 33626

Phone: 800-800-5441

Fax: 813-891-4056

www.jacoelectronics.com

Purchase Contact:

kbuelow@jacoelect.com

The Control Center provides the required formatting control codes for the printers above when the printer is selected on the PRINTER Screen in the instructions below. These codes are transmitted through the serial interface to the printer to provide a proper print format. Different printers require different formatting control codes. Other printers might provide proper operation when connected to the Control Center. However, the print format may not be correct or as desired. Proceed with caution and use the following guidelines if an unlisted printer is selected:

1. All must be capable of RS-232 Serial communications.
2. Primary differences between printers involve the formatting control codes required by the printer. These codes are sent from the Control Center to the printer. For example, Weigh-Tronix printers require a control code to select 40 column width. This same code is interpreted by the Okidata printer as an instruction to print wide characters. In some instances, a printer will ignore a code it cannot interpret.
3. The Control Center requires a busy signal from the printer when the printer receive buffer is full. This causes the Control Center to momentarily terminate data transmission until the printer can accept more data. The busy signal polarity must be asserted low when busy.

Printer Connections

Connect the printers to the Control Center Microboard as follows. Only one printer can be connected at a time.

SEIKO

Microboard	Printer	Function
J2-4	pin 3	Tx (data to printer)
J2-2	pin 8	DSR (busy signal from printer)
J2-9	pin 5	Gnd
Cabinet		Shield

Hardware required

Cable – #18 AWG stranded 50 ft. maximum length.

Connectors –

- Microboard: None. Strip 1/4" insulation from wire and insert into screw terminal block.
- Printers: Seiko - 9-Pin D-type Subminiature (DB-9 pin male).

Printer Setup

The printer must be configured as follows. Refer to manual provided by Printer manufacturer with respective Printer.

If equipped with HIGH SPEED serial board:

- SW1 - off (-) Low when busy
- 2 - off 1200 Baud*
- 3 - off 1200 Baud*
- 4 - on 1200 Baud*
- 5 - Not Used
- 6 - off no parity
- 7 - off Pin 20 & pin 11 act as busy line

SEIKO

- DipSW1-1 = off Input-Serial
- 1-2 = on Printing speed high
- 1-3 = on Auto loading - on
- 1-4 = off Auto LF - off
- 1-5 = on Setting Command - Enable
- 1-6 = off Printing density - 100%
- 1-7 = on Printing density - 100%
- 1-8 = on Printing, density - 100%

- DipSW 2-1 = off Printing Columns - 80
- 2-2 = on User Font Back-up - on
- 2-3 = on Character Select - normal
- 2-4 = off Zero - slash
- 2-5 = on International character set - American
- 2-6 = on International character set - American
- 2-7 = on International character set - American
- 2-8 = off International character set - American

- DipSW 3-1 = on Data length - 8 bits
- 3-2 = on Parity Setting - no
- 3-3 = on Parity condition - odd
- 3-4 = on Busy control - H/W busy
- 3-5 = off Baud rate select - 19.200*
- 3-6 = on Baud rate select - 19.200*
- 3-7 = on Baud rate select - 19.200*
- 3-8 = off Baud rate select - 19.200*

* Settings shown for 1200 Baud. Other Baud rates can be selected. Refer to Printer manufacturer's manual supplied with Printer.

Control Center Setup

Printer Setup

Access Level Required: OPERATOR

Using the COMMS Screen, the Control Center must be configured to transmit data in the same format as the Printer is configured to receive the data. The following values must be entered.

- Baud Rate - Set as desired. Value selected must be the same as Printer configuration above.
- Data Bits - 8
- Parity - None
- Stop Bits - 1

```

YORK A JOHNSON CONTROLS COMPANY

UNIT MODEL <>                SERIAL NUMBER <>
<DATE>, <HOUR>
TOTAL OPERATING HOURS <> [HOURS]
LATEST RUN TIME <> [DAYS, HOURS, MINUTES]
SOFTWARE VERSION <>

- O P E R A T I N G   D A T A   R E P O R T -

SYSTEM STATUS <>
CONTROL STATUS <>
SYSTEM DETAILS <>, <>, <>

RETURNING CHILLED LIQUID TEMPERATURE..... <>
REFRIGERANT TEMPERATURE..... <>
REFRIGERANT TEMPERATURE..... <>
ADC LINE TEMPERATURE..... <>
STRONG SOLUTION TEMPERATURE..... <>
STRONG SOLUTION CONCENTRATION..... <>
SOLUTION TEMPERATURE LEAVING STS..... <>
REFRIGERANT FROM CONDENSER TEMPERATURE.... <>
MIN SOLUTION TEMP TO CRYSTALLIZE..... <>
RETURNING COOLING LIQUID TEMPERATURE..... <>
LEAVING COOLING LIQUID TEMPERATURE..... <>
ENTERING HOT WATER TEMPERATURE..... <>
STEAM TEMPERATURE IN..... <>
STEAM PRESSURE..... <>
MAX ALLOWED LOADING..... <>
CONTROL VALVE POSITION [%]..... <>
GENERATOR SHELL PRESSURE..... <>
LEAVING CHILLED LIQUID SETPOINT..... <>
REMOTE TEMP SETPOINT RANGE..... <>
REMOTE LOAD LIMIT..... <>
AUTOPURGE 7 DAY COUNTER..... <>
AUTOPURGE TOTAL COUNTER..... <>
PURGE TANK PRESSURE..... <>
PURGE PUMP PRESSURE..... <>
PULLDOWN SETPOINT TIME..... <>
PULLDOWN SETPOINT START..... <>
PULLDOWN SETPOINT STOP..... <>
CHILLED LIQUID PUMP RUN CONTACTS (ON/OFF).... <>
CONDENSER LIQUID PUMP RUN CONTACTS (ON/OFF)... <>
CHILLED LIQUID FLOW SWITCH (OPEN/CLOSE)..... <>
CONDENSER LIQUID FLOW SWITCH (OPEN/CLOSE).. <>
REFRIGERANT PUMP (ON/OFF)..... <>
SOLUTION PUMP (ON/OFF)..... <>
ABSORBER PUMP (ON/OFF) -IF FRANKLIN-..... <>
GENERATOR PUMP (ON/OFF) -IF FRANKLIN-..... <>
REFRIGERANT LEVEL SWITCH 1F (OPEN/CLOSE)..... <>
REFRIGERANT LEVEL SWITCH 3F (OPEN/CLOSE)..... <>
STABILIZER REFRIGERANT SOLENOID VALVE 2SOL
(OPEN/CLOSE)..... <>
REFRIGERANT LEVEL SOLENOID VALVE 3SOL
(OPEN/CLOSE)..... <>
MOTOR COOLANT SOLENOID VALVE 4SOL
(OPEN/CLOSE) -IF FRANKILN-..... <>

REV. 1.0 2008
    
```

3

**FIGURE 20 – SAMPLE PRINTOUT
(OPERATING DATA)**

```

YORK A JOHNSON CONTROLS COMPANY

UNIT MODEL <>                SERIAL NUMBER <>
<DATE>, <HOUR>
TOTAL OPERATING HOURS <> [HOURS]
LATEST RUN TIME <> [DAYS, HOURS, MINUTES]
SOFTWARE VERSION <>

- LAST NORMAL STOP REPORT -

SYSTEM STATUS <>
CONTROL STATUS <>
SYSTEM DETAILS <>, <>, <>

RETURNING CHILLED LIQUID TEMPERATURE..... <>
LEAVING CHILLED LIQUID TEMPERATURE..... <>
REFRIGERANT TEMPERATURE..... <>
ADC LINE TEMPERATURE..... <>
STRONG SOLUTION TEMPERATURE..... <>
STRONG SOLUTION CONCENTRATION..... <>
SOLUTION TEMPERATURE LEAVING STS..... <>
REFRIGERANT FROM CONDENSER TEMPERATURE... <>
MIN SOLUTION TEMP TO CRYSTALLIZE..... <>
RETURNING COOLING LIQUID TEMPERATURE..... <>
LEAVING COOLING LIQUID TEMPERATURE..... <>
ENTERING HOT WATER TEMPERATURE..... <>
STEAM TEMPERATURE IN..... <>
STEAM PRESSURE..... <>
MAX ALLOWED LOADING..... <>
CONTROL VALVE POSITION [%]..... <>
GENERATOR SHELL PRESSURE..... <>
LEAVING CHILLED LIQUID SETPOINT..... <>
REMOTE TEMP SETPOINT RANGE..... <>
REMOTE LOAD LIMIT..... <>
AUTOPURGE 7 DAY COUNTER..... <>
AUTOPURGE TOTAL COUNTER..... <>
PURGE TANK PRESSURE..... <>
PURGE PUMP PRESSURE..... <>
PULLDOWN SETPOINT TIME..... <>
PULLDOWN SETPOINT START..... <>
PULLDOWN SETPOINT STOP..... <>
CHILLED LIQUID PUMP RUN CONTACTS (ON/OFF).... <>
CONDENSER LIQUID PUMP RUN CONTACTS (ON/OFF)... <>
CHILLED LIQUID FLOW SWITCH (OPEN/CLOSE)..... <>
CONDENSER LIQUID FLOW SWITCH (OPEN/CLOSE).. <>
REFRIGERANT PUMP (ON/OFF)..... <>
SOLUTION PUMP (ON/OFF)..... <>
ABSORBER PUMP (ON/OFF) -IF FRANKLIN-..... <>
GENERATOR PUMP (ON/OFF) -IF FRANKLIN-..... <>
REFRIGERANT LEVEL SWITCH 1F (OPEN/CLOSE)..... <>
REFRIGERANT LEVEL SWITCH 3F (OPEN/CLOSE)..... <>
STABILIZER REFRIGERANT SOLENOID VALVE 2SOL
(OPEN/CLOSE)..... <>
REFRIGERANT LEVEL SOLENOID VALVE 3SOL
(OPEN/CLOSE)..... <>
MOTOR COOLANT SOLENOID VALVE 4SOL
(OPEN/CLOSE) -IF FRANKILN-..... <>

REV. 1.0 2008
    
```

FIGURE 21 – SAMPLE PRINTOUT
(LAST NORMAL STOP)

```

YORK A JOHNSON CONTROLS COMPANY

UNIT MODEL <>                SERIAL NUMBER <>
<DATE>, <HOUR>
TOTAL OPERATING HOURS <> [HOURS]
LATEST RUN TIME <> [DAYS, HOURS, MINUTES]
SOFTWARE VERSION <>

- SALES ORDER REPORT -

YORK ORDER                    <>
VOLTAGE                      <>
POWER CONSUMPTION            <>
COOLING CAPACITY.....       <> <>

DESIGN DATA                EN UNITS    SI UNITS

-EVAPORATOR-
EWT.....                   <>        <>
LWT.....                   <>        <>
FLOW.....                  <>        <>
PD.....                    <>        <>
PASS.....                  <>        <>
DWP.....                   <>        <>
FLUID TYPE.....            <>        <>
FLUID %.....               <>        <>
-ABSORBER/CONDENSER-
EWT.....                   <>        <>
LWT.....                   <>        <>
FLOW.....                  <>        <>
PD.....                    <>        <>
PASS.....                  <>        <>
DWP.....                   <>        <>
FLUID TYPE.....            <>        <>
FLUID %.....               <>        <>
-GENERATOR-
EWT.....                   <>        <>
LWT.....                   <>        <>
FLOW.....                  <>        <>
PD.....                    <>        <>
PASS.....                  <>        <>
DWP.....                   <>        <>
FLUID TYPE.....            <>        <>
FLUID %.....               <>        <>
STEAM CONSUMPTION.....     <>        <>
STEAM PRESSURE AT GEN... <>        <>
STEAM PRESSURE AT VALVE.<> <>

UNIT CONFIGURATION SETTINGS
CONTROL VALVE PART NUMBER.... <>
CONTROL VALVE DESCRIPTION.... <>
FRANKLIN OR BUFFALO PUMPS.... <>
UNIT MODEL.....            <>
ELECTRICAL CODE.....       <>
ENERGY SOURCE.....         <>
FLOW SWITCH TYPE.....      <>
LANGUAGE.....              <>
UNITS.....                 <>

REV 1.0 2008
    
```

FIGURE 22 – SAMPLE PRINTOUT (SALES ORDER)

YORK A JOHNSON CONTROLS COMPANY

UNIT MODEL <> SERIAL NUMBER <>
 <DATE>, <HOUR>
 TOTAL OPERATING HOURS <> [HOURS]
 LATEST RUN TIME <> [DAYS, HOURS, MINUTES]
 SOFTWARE VERSION <>

- H I S T O R Y F I L E R E P O R T -

FAULT <>
 CURRENT FAULT STATUS <>

SYSTEM STATUS <>
 CONTROL STATUS <>
 SYSTEM DETAILS <>, <>, <>

RETURNING CHILLED LIQUID TEMPERATURE..... <>
 LEAVING CHILLED LIQUID TEMPERATURE..... <>
 REFRIGERANT TEMPERATURE..... <>
 ADC LINE TEMPERATURE..... <>
 STRONG SOLUTION TEMPERATURE..... <>
 STRONG SOLUTION CONCENTRATION..... <>
 SOLUTION TEMPERATURE LEAVING STS..... <>
 REFRIGERANT FROM CONDENSER TEMPERATURE.... <>
 MIN SOLUTION TEMP TO CRYSTALLIZE..... <>
 RETURNING COOLING LIQUID TEMPERATURE..... <>
 LEAVING COOLING LIQUID TEMPERATURE..... <>
 ENTERING HOT WATER TEMPERATURE..... <>
 STEAM TEMPERATURE IN..... <>
 STEAM PRESSURE..... <>
 MAX ALLOWED LOADING..... <>
 CONTROL VALVE POSITION [%]..... <>
 GENERATOR SHELL PRESSURE..... <>
 LEAVING CHILLED LIQUID SETPOINT..... <>
 REMOTE TEMP SETPOINT RANGE..... <>
 REMOTE LOAD LIMIT..... <>
 AUTOPURGE 7 DAY COUNTER..... <>
 AUTOPURGE TOTAL COUNTER..... <>
 PURGE TANK PRESSURE..... <>
 PURGE PUMP PRESSURE..... <>
 PULLDOWN SETPOINT TIME..... <>
 PULLDOWN SETPOINT START..... <>
 PULLDOWN SETPOINT STOP..... <>
 CHILLED LIQUID PUMP RUN CONTACTS (ON/OFF)..... <>
 CONDENSER LIQUID PUMP RUN CONTACTS (ON/OFF)... <>
 CHILLED LIQUID FLOW SWITCH (OPEN/CLOSE)..... <>
 CONDENSER LIQUID FLOW SWITCH (OPEN/CLOSE).. <>
 REFRIGERANT PUMP (ON/OFF)..... <>
 SOLUTION PUMP (ON/OFF)..... <>
 ABSORBER PUMP (ON/OFF) -IF FRANKLIN-..... <>
 GENERATOR PUMP (ON/OFF) -IF FRANKLIN-..... <>
 REFRIGERANT LEVEL SWITCH 1F (OPEN/CLOSE)..... <>
 REFRIGERANT LEVEL SWITCH 3F (OPEN/CLOSE)..... <>
 STABILIZER REFRIGERANT SOLENOID VALVE 2SOL
 (OPEN/CLOSE)..... <>
 REFRIGERANT LEVEL SOLENOID VALVE 3SOL
 (OPEN/CLOSE)..... <>
 MOTOR COOLANT SOLENOID VALVE 4SOL
 (OPEN/CLOSE) -IF FRANKILN-..... <>

REV. 1.0 2008

YORK A JOHNSON CONTROLS COMPANY

UNIT MODEL <> SERIAL NUMBER <>
 <DATE>, <HOUR>
 TOTAL OPERATING HOURS <> [HOURS]
 LATEST RUN TIME <> [DAYS, HOURS, MINUTES]
 SOFTWARE VERSION <>

- P U R G E T R E N D R E P O R T -

INTERVAL TIME SETUP <> [HOURS]
 TREND START <DATE>, <HOUR>
 SET MIN <>
 SET MAX <>
 AUTOPURGE 7 DAY COUNTER <>

INTERVAL	DIFF PRESSURE [MMHG]	PURGE TANK PRESS [MMHG]
0	<>	<>
1	<>	<>
2	<>	<>
3	<>	<>
4	<>	<>
5	<>	<>
6	<>	<>
7	<>	<>
8	<>	<>
9	<>	<>
10	<>	<>
11	<>	<>
12	<>	<>
13	<>	<>
14	<>	<>
15	<>	<>
16	<>	<>
17	<>	<>
18	<>	<>
19	<>	<>
20	<>	<>
21	<>	<>
22	<>	<>
23	<>	<>
24	<>	<>
25	<>	<>
26	<>	<>
27	<>	<>
28	<>	<>
29	<>	<>

REV. 1.0 2008

3

FIGURE 23 – SAMPLE PRINTOUT (HISTORY)

FIGURE 24 – SAMPLE PRINTOUT (PURGE TREND)

YORK A JOHNSON CONTROLS COMPANY

UNIT MODEL <>

SERIAL NUMBER <>

<DATE>, <HOUR>

TOTAL OPERATING HOURS <> [HOURS]

LATEST RUN TIME <> [DAYS, HOURS, MINUTES]

SOFTWARE VERSION <>

- S E T P O I N T S L I S T R E P O R T -

SETPOINT	VALUE	MIN	MAX	DEFAULT
LEAVING CHILLED LIQUID TEMP	<>	40°F	77°F	44°F
LOW UNLOAD LIMIT	<>	10%	20%	10%
MAXIMUM LOAD LIMIT	<>	50%	100%	100%
SHORT DILUTION CYCLE	<>	DISABLE	ENABLE	ENABLE
AUTOMATIC RESTART AFTER POWER FAILURE	<>	MANUAL	AUTO	AUTO
LCHLT RATE LIMIT	<>	0.1°F	5.0°F	1.0°F
LCHLT ERROR LIMIT	<>	0.1°F	10.0°F	6.0°F
LCHLT MAXIMUM OUTPUT DIFFERENTIAL	<>	0.05	0.5	0.2
SSC RATE LIMIT	<>	0.10%	2.00%	0.60%
SSC ERROR LIMIT	<>	0.10%	2.00%	0.50%
SSC MAXIMUM OUTPUT DIFFERENTIAL	<>	0.05	0.5	0.2
SAMPLE FACTOR	<>	30SEC	180SEC	60SEC
PERCENT FULL VALVE STROKE	<>	50%	130%	100%
PURGE PUMP SERVICE INTERVAL	<>	5HRS	100HRS	10HRS
MAXIMUM PURGE/WEEK	<>	2	6	4
PURGE PUMP WARM UP TIME	<>	2MIN	20MIN	2MIN
LCHLT SHUTDOWN OFFSET	<>	2°F	4°F	3°F
RT10 STRONG SOLN FROM STS TEMP OFFSET	<>	-5°F	5°F	0°F
RT9 CONDENSED REFRIGERANT TEMP OFFSET	<>	-5°F	5°F	0°F
RT3 STRONG SOLN FROM GEN TEMP OFFSET	<>	-5°F	5°F	0°F
REFRIGERANT PUMP SHUTOFF DELAY	<>	1SEC	45SEC	30SEC
REFRIGERANT PUMP STARTUP DELAY	<>	1SEC	900SEC	120SEC
CHILLER REFRIGERANT LEVEL SHUTDOWN DELAY	<>	20MIN	60MIN	30MIN
MOTOR COOLANT SOLENOID OPEN TEMP	<>	127°F	160°F	160°F
REMOTE LCHLT RESET RANGE	<>	10°F	40°F	20°F
PULLDOWN LOADING START SETPOINT	<>	10%	30%	10%
PULLDOWN LOADING STOP SETPOINT	<>	20%	100%	100%
PULLDOWN INTERVAL TIMER	<>	0MIN	255MIN	0MIN
RAMPDOWN INTERVAL TIMER	<>	0MIN	60MIN	0MIN

REV. 1.0 2008

FIGURE 25 – SAMPLE PRINTOUT (SETPOINTS)

DOWNLOADING SYSTEM HISTORIES TO A LAPTOP FROM AN OPTIVIEW CONTROL PANEL

Downloading histories to a file is another useful method to capture system operating conditions. The following instructions are to establish communication between the OptiView Control Panel and a laptop computer.

1. Connect the laptop computer to the OptiView as shown.

Laptop (RS-232 Serial Port)			OptiView (Com 1)	
PIN	DESC		Connector	Terminal
2	RX	to	J2	4 (TXD1)
3	DTR	to	J2	3 (RXD1)
5	GND	to	J2	9 GND

2. Setup HyperTerminal
 - a. Go to START menu
 - b. Select All Programs
 - c. Select Accessories
 - d. Select Communications
 - e. Select HyperTerminal
 - f. In the box displayed, it requires a name and icon for the connection. Select a name that is descriptive and select an icon. Select OK.
 - g. In the box labeled Connect using the select com port that will connect to the YIA unit. This port is usually labelled Com 1. Select OK.
 - h. Port settings

Bits per second	57600
Data bits	8
Parity	None
Stop Bits	1
Flow control	None
3. Set HyperTerminal to capture a file.
 - a. Select Transfer from toolbar
 - b. Select Capture Text from the drop down menu.
 - c. A capture Text Filebox will be displayed. Verify location and file name.
 - d. Select Start.

4. Press the the Print Screen key on the appropriate screen to be captured. The HyperTerminal will display the printed information and the information will be recorded as a .txt file.

When the print file has been recorded, select Transfer from the toolbar and capture from the drop down menu and select Stop. This will stop the transfer and allow access to the capture file.

The following additional RS232 connections, and wiring up serial devices for desktop and laptop computers.

RS-232 Pin Assignments (DB25 PC signal set) (Older Desktops Only)	
Pin 1	Protective Ground
Pin 2	Transmit Data
Pin 3	Recieved Data
Pin 4	Request To Send
Pin 5	Clear To Send
Pin 6	Data Set Ready
Pin 7	Signal Ground
Pin 8	Recieved line Signal Detector (Data Carrier Detect)
Pin 20	Data Terminal Ready
Pin 22	Ring Indicator

The connector on the PC has Male pins, therefore the mating cable needs to terminate in a DB25/F (Female pin) connector.

RS-232 Pin Assignments (DB9 PC signal set) (Most Laptops)	
Pin 1	Recieved line Signal Detector (Data Carrier Detect)
Pin 2	Recieved Data
Pin 3	Transmit Data
Pin 4	Data Terminal Ready
Pin 5	Signal Ground
Pin 6	Data Set Ready
Pin 7	Request To Send
Pin 8	Clear To Send
Pin 9	Ring Indicator

The connector on the PC has Male pins, therefore the mating cable needs to terminate DB9/F (Female pin) connector.

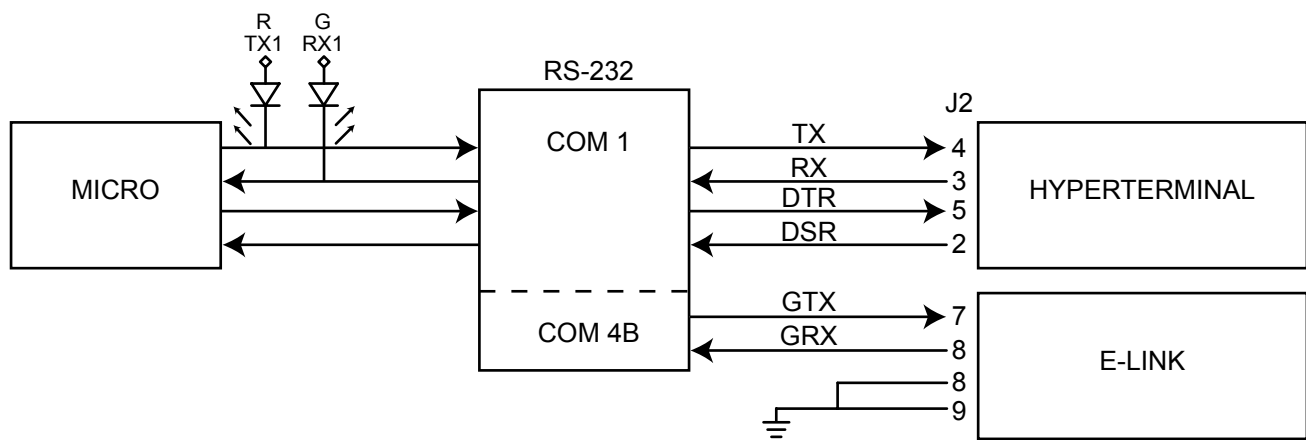

FIGURE 26 – COMMUNICATIONS BLOCK DIAGRAM

LD14492

SI METRIC CONVERSION

The following factors can be used to convert from English to the most common SI Metric values.

MEASUREMENT	MULTIPLY THIS ENGLISH VALUE	BY	TO OBTAIN THIS METRIC VALUE
CAPACITY	TONS REFRIGERANT EFFECT (ton)	3.516	KILOWATTS (kW)
POWER	KILOWATTS (kW)	NO CHANGE	KILOWATTS (kW)
	HORSEPOWER (hp)	0.7457	KILOWATTS (kW)
FLOW RATE	GALLONS / MINUTE (gpm)	0.0631	LITERS / SECOND (L/s)
LENGTH	FEET (ft)	304.8	MILLIMETERS (mm)
	INCHES (in)	25.4	MILLIMETERS (mm)
WEIGHT	POUNDS (lb)	0.4536	KILOGRAMS (kg)
VELOCITY	FEET / SECOND (fps)	0.3048	METERS / SECOND (m/s)
PRESSURE DROP	FEET OF WATER (ft)	2.989	KILOPASCALS (k Pa)
	POUNDS / SQ. INCH (psi)	6.895	KILOPASCALS (k Pa)

TEMPERATURE:

To convert degrees Fahrenheit (°F) to degrees Celsius (°C) subtract 32° and multiply by 5/9 or 0.5556.

To convert a temperature range (i.e., 10°F or 12°F chilled water range) from Fahrenheit to Celsius, multiply by 5/9 or 0.5556.



BY JOHNSON CONTROLS