



## "Production" Burner Specification Sheet

Job Number	J018750-	Qty	1	Order Number	B011075	Line Number	1
Customer	YORK AIRE S. DE R.L. DE CV			Purchase Order			
Job Name							
Burner Model	CR3-G-25			Serial Number			
Burner Mode of Operation	MOD ODP						
Code	UL,CSD-1						
UL Label							
Heat Exchanger Make	YOTK	Heat Exchanger Model	14SC/15S				
Heat Exchanger Type	CHILLER						
Combustion Chamber Pressure	2.5						
Job Site Altitude	2,000ft	Clearance Checked By	TED				
Clipped Circuit Board PN							
Gas High Fire Rate	3613	MBH					
Oil High Fire Rate		GPH		PSIG Pump			
Fuel Oil Grade							
UL Group - Gas	4D	UL Group - Oil					
Gas Type	NATURAL						
High Fire Manifold Pressure**	5.1	IN. WC		Side Orifice Drill Size	N/A		
Gas Regulator Outlet Pressure	7.2	IN. WC		RPTD Job Pressure	14.0	IN. WC	
Minimum Supply Pressure	10.3	IN. WC		Max Design Pressure *	28.0	IN. WC	
Wiring Diagram	G-22224L						
Gas Piping Diagram	1996-5						
Oil Piping Diagram							
General Arrangement Drawing	I-2455LC	Additional Drawings					
Additional Drawings	G-22223L	Additional Drawings					
Additional Drawings							
Control Voltage	115V	Single Phase	60	HZ	Full Load Amps	6.0	
Blower Motor Voltage	460V	3	PH	60	HZ	Full Load Amps	2.5
Oil Pump Motor Voltage			PH		HZ	Full Load Amps	
Compressor Motor Voltage			PH		HZ	Full Load Amps	
Minimum Circuit Ampacity	12.00				Gas Inlet Location	SIDE	
Ignition System	GAS PILOT SCANNER						
Diffuser Blade Setting	1/4	Blast Tube Flange Set	5.25				

**Comments:**

9W X 10H BURNER MTD 22W X 24H REMOTE PANEL  
 PREPIPED & PREWIRED, PAINTED GAS TRAIN PER STYLE "B"  
 1-1/8 HOLE IN BOTTOM PF EACH PANEL ON LEFT HAND SIDE  
 VARICAM SINGLE FUEL METERING SYSTEM

**\*\*Approximate operating pressure at the Manifold Inlet for initial start-up. Final Pressure should be determined after checking actual flow with gas meter. Stack temperature, CO, CO2, O2, and Furnace Pressure will help in determining actual input when gas meter is not available for this unit.**

**\*All components are rated for the Max Design Pressure specified, that pressure must not be exceeded.**

IT SHALL NOT BY REPRODUCED, IN WHOLE OR IN PART, AND SHALL NOT BE DISCLOSED TO ANYONE OUTSIDE POWER FLAME WITHOUT THE PRIOR EXPRESS APPROVAL OF POWER FLAME

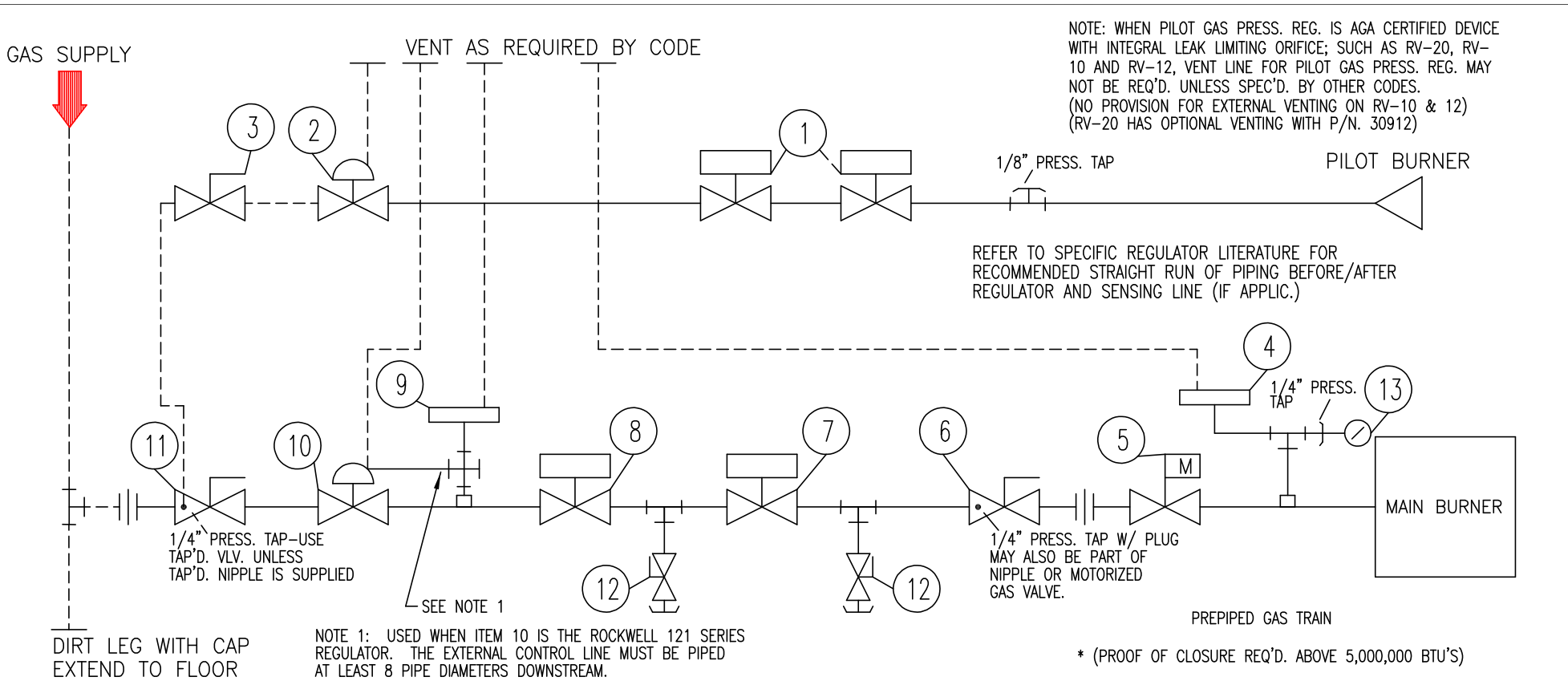

NOTE: WHEN PILOT GAS PRESS. REG. IS AGA CERTIFIED DEVICE WITH INTEGRAL LEAK LIMITING ORIFICE; SUCH AS RV-20, RV-10 AND RV-12, VENT LINE FOR PILOT GAS PRESS. REG. MAY NOT BE REQ'D. UNLESS SPEC'D. BY OTHER CODES. (NO PROVISION FOR EXTERNAL VENTING ON RV-10 & 12) (RV-20 HAS OPTIONAL VENTING WITH P/N. 30912)

REFER TO SPECIFIC REGULATOR LITERATURE FOR RECOMMENDED STRAIGHT RUN OF PIPING BEFORE/AFTER REGULATOR AND SENSING LINE (IF APPLIC.)

NOTE 1: USED WHEN ITEM 10 IS THE ROCKWELL 121 SERIES REGULATOR. THE EXTERNAL CONTROL LINE MUST BE PIPED AT LEAST 8 PIPE DIAMETERS DOWNSTREAM.

\* (PROOF OF CLOSURE REQ'D. ABOVE 5,000,000 BTU'S)

EQUIPMENT SHOWN ON DIAGRAM IS ONLY PROVIDED AND MOUNTED BY POWER FLAME IF SPECIFICALLY CALLED FOR ON BURNER SPEC. SHEET.

————— FACTORY PIPED  
 - - - - - FIELD PIPED

CAUTION: ALL FIELD PIPED COMPONENTS MUST BE MOUNTED IN THE PROPER LOCATION AND PROPER DIRECTION OF GAS FLOW.

1	PILOT SOLENOID VALVE	13	GAS PRESS. GAUGE
2	PILOT PRESS. REGULATOR	12	TEST COCK (1/4" COMBU)
3	PILOT SHUTOFF COCK	11	MAIN GAS SHUTOFF COCK W/ HANDLE
4	HIGH GAS PRESS. SW.	10	MAIN GAS PRESSURE REGULATOR
5	MOD. BUTTERFLY VALVE	9	LOW GAS PRESSURE SW.
6	LEAKAGE TEST COCK	8	AUX. GAS VALVE
7	MAIN GAS VALVE *		

## Power Flame Incorporated



2001 SOUTH 21st STREET      PHONE (620) 421-0480  
 PARSONS, KANSAS 67357      FAX (620) 421-0948

5 ADDED NOTE 1 & EXT. CONTROL LINE	MH/RAP	10/28/97
4 UPDATED	DL	10/21/97
3 CAPPED ITEM 12	DK	10/21/93
2 ADDED SECOND ITEM 1	DK/NF	2/21/92
1 ADDED ITEM 13	DK/NF	2/19/92
REVISION	REV'D.	DATE

DRAWN: KIDD	APPVD: DP	FILE: AC	DATE: 2/13/92	PARENT: 1915	DWG.: PDG-1996-5
DRAWING PARAMETERS:					
TITLE: GAS PIPING FOR MODULATING BURNERS WITH INPUTS BELOW 12,500,000 BTU's.				JOB NAME: YORK	
				CODE: UL/CSD	

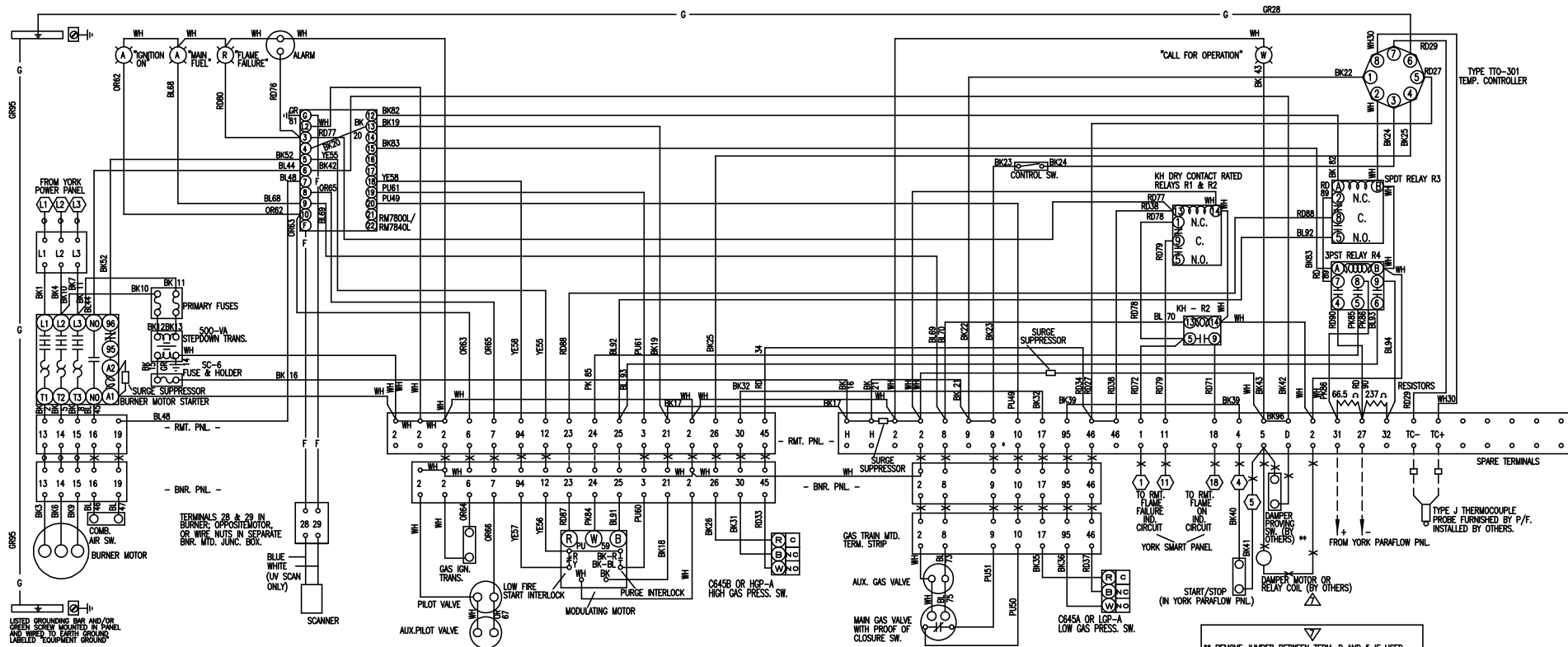
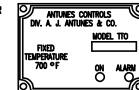

TYPE TT0-301  
TEMP. CONTROLLER

\*\* REMOVE JUMPER BETWEEN TERM. D AND 5 IF USED.  
NOTE: COMB. DAMPER CIRCUITRY SHOWN FOR SINGLE BURNER SINGLE DAMPER INSTALLATION. FOR MULTIPLE BURNER/SINGLE DAMPER INSTALLATION SEE DIAGRAM NO. WE-557.

"USE COPPER CONDUCTORS ONLY."  
CAUTION: THROW ALL DISCONNECTS TO OFF BEFORE SERVICING.

- G — EQUIPMENT GND. CONDUCTOR
- F — FLAME CIRCUIT: RUN IN SEPARATE CONDUIT OR SHIELDED CABLE
- — — FACTORY WIRING
- - - - 24V FIELD WIRING
- x - 115V FIELD WIRING
- o - 200- FOR VOLTAGE

EQUIPMENT SHOWN ON DIAGRAM IS ONLY PROVIDED AND MOUNTED BY POWER PLANT IF SPECIFICALLY CALLED FOR ON BURNER SPEC. SHEET

SINGLE VALVE WITH P.O.C. MAY ONLY AUX. GAS VALVE. (APPLICABLE TO UNITS WITH INPUTS BELOW 5,000 MBH)

\* JUMP TERM. 9 TO 10 VIA PURPLE LEAD IF PROOF OF CLOSURE IS NOT REQUIRED.

CAUTION: ALL FIELD WIRING MUST BE WIRED AS SHOWN ON WIRING DIAGRAM

RELAYS R1 & R2

REF. R10	KUP	KH
COIL	7	13
NEUT.	2	14
COM.	1	9
N.O.	3	5
N.C.	4	1

COLOR CODE

BK	- BLACK
WH	- WHITE
RD	- RED
PK	- PINK
BL	- BLUE
OR	- ORANGE
YL	- YELLOW
PU	- PURPLE
GR	- GREEN

CROSS REFERENCE RELAY LEGEND

P-T-P	JC
DWG. NO. G-2224L	G-2222L

R1 - 41CR - FLAME FAILURE  
R2 - 3SCR - FLAME ON  
R3 - 4SCR - OPEN DAMPER PURGE  
R4 - 47CR - RUN

REMOTE PNL. MUST BE BONDED TO BURNER BY FLEXIBLE OR RIGID METAL CONDUIT AND METAL CONDUIT CONNECTORS.

— ) TERMINALS IN YORK CONTROL PNL.

<p><b>Power Flame Incorporated</b></p> <p>2001 SOUTH 21st STREET    PHONE (620) 421-0480 PARSONS, KANSAS 67357    FAX (620) 421-0948</p>		
<p>DRAWING PARAMETERS: YCGX-RM7800L1012/U-MFN-HX-IT-TT-F7-WF-XX-XO-AA-XXX-XX-XHO-JOO</p>	<p>1 REV'D, DRAWING # ON RELAY CROSS REFERENCE    MH/CH    05/10/04</p>	<p>TITLE: GAS BURNER WITH RM7800L OR RM7840L, MODULATION, 3PH. MOTOR, 4 LIGHTS AND SCANNER.</p>
<p>REVISION</p>	<p>REV'D.    DATE</p>	<p>JOB NAME: YORK CODE: UL/CSD-1</p>

IT SHALL NOT BE REPRODUCED, IN WHOLE OR IN PART, AND SHALL NOT BE DISCLOSED TO ANYONE OUTSIDE POWER PLANT WITHOUT THE PRIOR EXPRESS APPROVAL OF POWER PLANT.

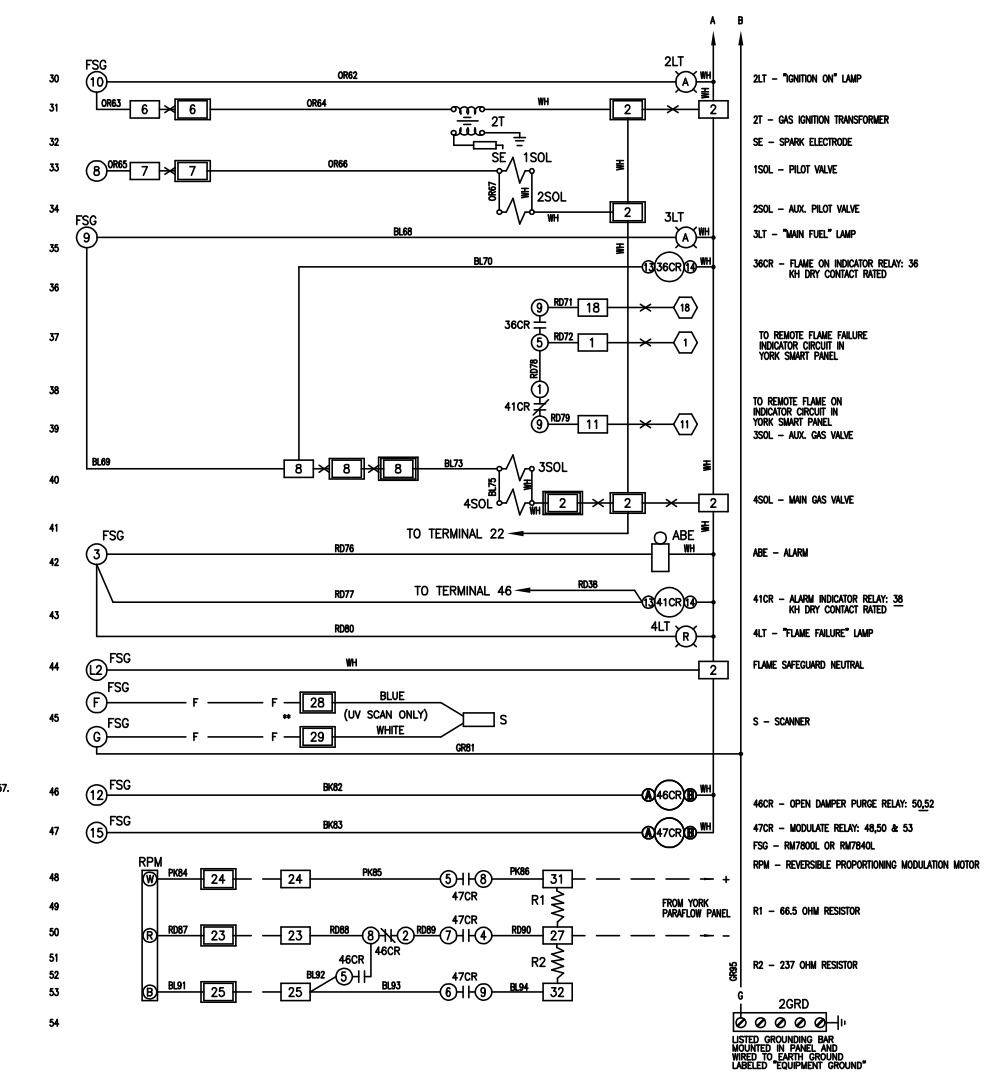
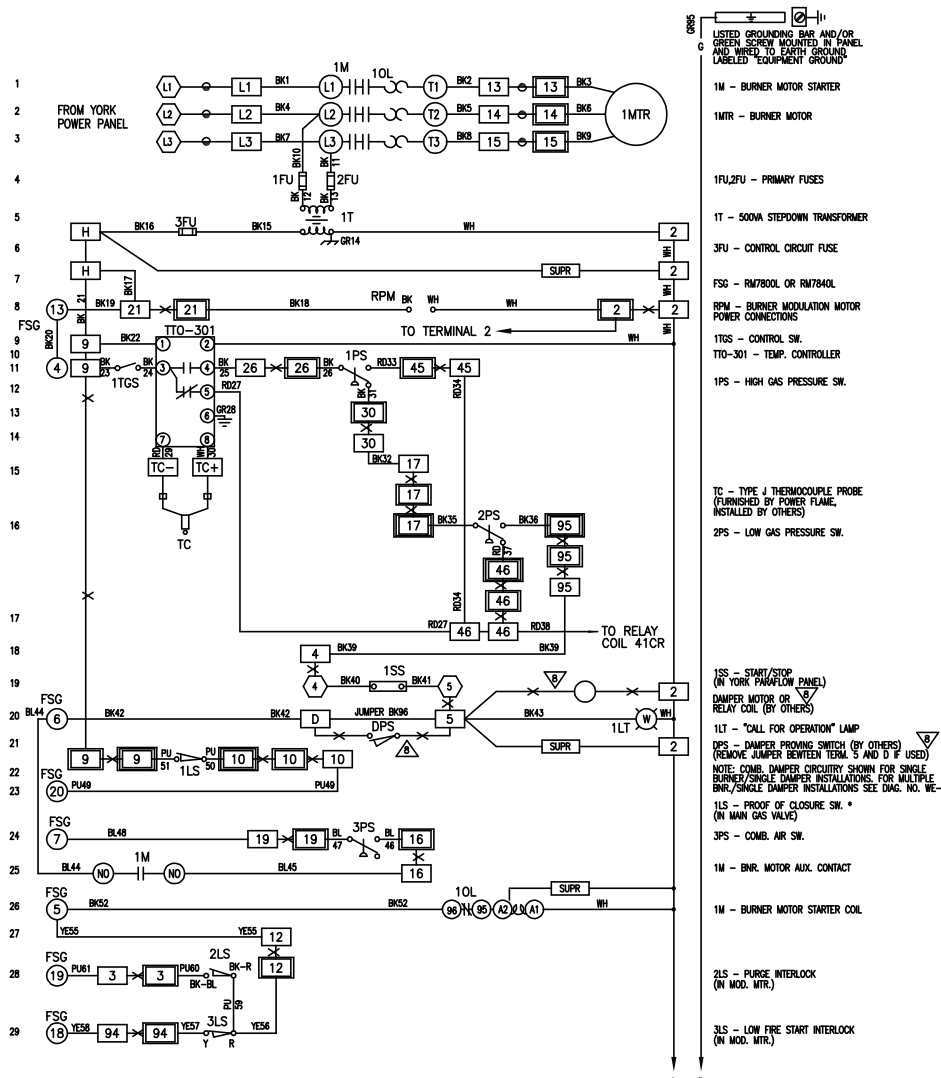

TERMINAL STRIP ARRANGEMENT OF POINT TO POINT DIAGRAM NO. G-22041L

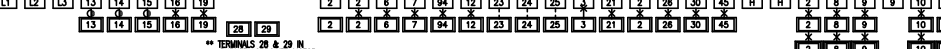

REMOTE PNL. MUST BE BONDED TO BURNER BY FLEXIBLE OR RIGID METAL CONDUIT AND METAL CONDUIT CONNECTORS.

\* JUMP TERM. 9 TO 10 VIA PURPLE LEAD IF PROOF OF CLOSURE IS NOT REQUIRED.  
 SINGLE VALVE WITH P.O.C. SW. MAY OMIT AUX. GAS VALVE. (APPLICABLE TO UNITS WITH INPUTS BELOW 5.000 MSH)

"USE COPPER CONDUCTORS ONLY."  
 CAUTION: THROW ALL DISCONNECTS TO OFF BEFORE SERVICING.

EQUIPMENT SHOWN ON DIAGRAM IS ONLY PROVIDED AND MOUNTED BY POWER FLAME IF SPECIFICALLY CALLED FOR ON BURNER SPEC. SHEET

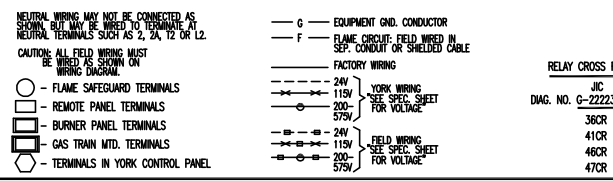

RELAYS 36CR & 41CR

REF.	R10	KUP	KH
COIL	7	A	13
NEU.	2	A	14
COIL	1	2A	9
N.O.	3	4.5A	5
N.C.	4	1.2A	1

LAST WIRE NO. USED - 97

**Power Flame Incorporated**

2001 SOUTH 21st STREET PHONE (620) 421-0480  
 PARSONS, KANSAS 67357 FAX (620) 421-0948

DRAWN: CB APPVD: CH FILE: AC DATE: 3/7/04 PARENT: 22042 DWG.: G-2223L-1

DRAWING PARAMETERS: LCGX-RM7800L1012/U-MFN-HX-IX-TT-F7-WF-XX-X-NO-AA-XXX-XX-XHO-JOO

1 REV'D. DRAWING # ON RELAY CROSS REFERENCE MH/CH 05/10/04 TITLE: GAS BURNER WITH RM7800L OR RM7840L, MODULATION, 3PH. MOTORS, 4 LIGHTS AND SCANNER. JOB NAME: YORK CODE: UL/CSD-1

IT SHALL NOT BE REPRODUCED, IN WHOLE OR IN PART, AND SHALL NOT BE DISCLOSED TO ANYONE OUTSIDE POWER FLAME WITHOUT THE PRIOR EXPRESS APPROVAL OF POWER FLAME.



**SPECIFICATION SHEET**

Date: 7/16/2004

## Submittal For Record

Page 1 of 4

Customer: YORK AIRE S de RL de CV - 36635

Purchase Order: 30025

Job Number: J018750 - 0

Item: CR3-G-25

Qty: 1.00

Order Number: B011075 - 1

Material	Qty	U/M	Material Description	Ship Loose
004660	7.00	FT	LD-500-1 LOW DENSITY 1/2 INCH 1000 DEGREE FIBREGLASS BRAIDED ROPE P/N 21032	L
057240	1.00	EA	1-1/2 HP 3450 RPM 208/230/460 /3 ODP 56C 56T34D5314 MARATHON MOTOR REPLACED BY 05425	
060250	1.00	EA	M9174C-1025/P 120 V. H.W. MODUTROL MOTOR WITH LOW FIRE START & PURGE INTERLOCKS	
061230	1.00	EA	4074 EDC HONEYWELL RESISTOR PACK FOR M954,M955,M974,M975 MOD MOTORS	
081750	1.00	EA	8-1/4 X 3-1/2 X 5/8 D-HUB R825-350S 3450 CW. SPEC. 1-6465 REVCOR WHEEL	
140700	1.00	EA	CRTP1A9M9 OSLO SPST ROCKER SWITCH	
161000	1.00	EA	LGP-G 1-20 INCH ANTUNES LOW GAS PRESSURE SWITCH MANUAL RESET (VENTLESS)	
161100	1.00	EA	HGP-G 2-20 INCH ANTUNES HIGH GAS PRESSURE SWITCH MANUAL RESET (VENTLESS)	
170000	1.00	EA	AFS-A CLEVELAND CONTROLS AIR SWITCH .05- 12" W.C.,1-14 UNS MOUNTING	
202450	2.00	EA	U28-45-21-18 1/4" OR 8040H007 (SV311A02N6BF5) 120 VOLT 50/60 HZ. GAS PILOT VALVE	
273730	1.00	EA	501212-1 110 BVR 2-1/2 INCH ECLIPSE REDUCED PORT MANUAL BUTTERFLY VALVE	
281100	2.00	EA	S261SF02N3JK4 2 INCH 25PSI 120 VOLT 4,180,000 BTU 1 INCH PD 17.5 WATTS ASCO SOLENOID VALVE	
300700	1.00	EA	RV-81 1-1/2 INCH MAXITROL REGULATOR W/ R8110-38 PINK 3-8 " SPRING	
302800	1.00	EA	325-3 3/8 INCH MAXITROL REGULATOR WITH R325C10-26 CAD PLATED 2-6" SPRING	
310340	1.00	EA	R8110-412 VIOLET 4-12 INCH SPRING FOR MAXITROL RV-81 & 21OD REGULATOR	
320000	1.00	EA	1092-PF 6000V. 50/60 HZ. ALLANSON GAS IGNITION TRANSFORMER	
333000	1.00	EA	164447 480/240/208 TO 120 50/60 HZ. HAMMOND TRANSFORMER WITH FUSE BLOCKS	
397520	1.00	EA	RM7840L-1018 HONEYWELL AUTOMATIC PROGRAMMING CONTROL WITH O DISPLAY 50/60 HZ.	
400910	1.00	EA	Q7800B-1003 HONEYWELL UNIVERSAL WIRING SUBBAS E-METAL BURNER MOUNT	
403200	1.00	EA	C7027A-1023 CUSTOM PAK UV 1/2" NPT. MOUNTING 0-215DEG HONEYWELL FLAME SENS	

# SPECIFICATION SHEET

Date: 7/16/2004

## Submittal For Record

Page 2 of 4

Customer: YORK AIRE S de RL de CV - 36635

Purchase Order: 30025

Job Number: J018750 - 0

Item: CR3-G-25

Qty: 1.00

Order Number: B011075 - 1

Material	Qty	U/M	Material Description	Ship Loose
403200...	1.00...	EA...	STD CNDT CNNCT	...
406950	1.00	EA	R7849A-1023 HONEYWELL UV AMP 3 SECOND FLAME FAILURE RESPONSE TIME	
407710	1.00	EA	ST7800A-1039 HONEYWELL 30 SECOND PURGE TIMER	
463100	1.00	EA	0-18 OZ. 0-32 INCH 2-1/2 INCH DIAL 1/4 INCH LM CONNECTION WINTERS GAUGE P301	L
500520	3.00	EA	PMR210ME6100M100 EVOX-RIFA NOISE SUPPRESSOR	
500700	1.00	EA	TT0301 (8653010170 ANTUNES TEMP. CONTROL PRESET 600 DEG. W/ IND. & MAN. RESET	
553870	2.00	EA	20C297 HOLD DOWN CLIP FOR P & B KHAU RELAY	
553900	1.00	EA	0T08-PC CUSTOM CONNECTOR 8 PIN SOCKET FOR KRP SERIES RELAYS	
554300	2.00	EA	27E894 DIN RAIL SOCKET FOR KHAU RELAY	
554710	2.00	EA	KHAU-17A16-120 (4PDT) P & B RELAY	
555500	2.00	EA	5533 8 120 00 00 3PDT FINDER RELAY	
555510	2.00	EA	94.73 3PDT BASE FOR FINDER 55 SERIES RELAY	
572080	1.00	EA	A9S-84J 3 POLE 120/60 9 AMP 2/2/5/7.5 HP ABB STARTER 2.2-3.1 AMP OVERLOAD	
610400	2.00	EA	SLU-35 ILSCO GROUNDING LUG	
612010	70.00	EA	019904225 ENTRELEC D6/8.ADO 14-16 GAGE A DO, SCREW TERMINAL, GREY BLOCK	
612070	9.00	EA	0115120.17 ENTRELEC M10/10 SCREW TERMINAL 6-20 GA,65A.	
612110	2.00	EA	0115206.22 ENTRELEC MTC6 THERMOCOUPLE BLOCK	
612130	2.00	EA	0199075.26 ENTRELEC D6/8.ADO 14-16 GA. A QO,SCREW TERMINAL RED (GAS VALVE)	
612140	3.00	EA	0199070.05 ENTRELEC D4/6.ADO 16-22 GA. A DO,SCREW TERMINAL IVORY	
633400	1.00	EA	SC110N MALLORY PANEL MOUNT SONALERT BUZZER 120 VOLT	
654000	1.00	EA	SGTX25-6M9 120V. OSLO WHITE INDICATOR LIGHT	
654010	2.00	EA	SGTX25-3M9 120V. OSLO AMBER INDICATOR LIGHT	
654020	1.00	EA	SGTX25-1M9 120V. OSLO RED INDICATOR LIGHT	
690120	1.00	EA	PYROMATION J20-1-507 TYPE J THERMOCOUPLE WIRE (50 FT. ROLL)	L
690320	1.00	EA	J43G-012-01A-22CF31 PYROMATION	L

**SPECIFICATION SHEET**

Date: 7/16/2004

## Submittal For Record

Page 3 of 4

Customer: YORK AIRE S de RL de CV - 36635

Purchase Order: 30025

Job Number: J018750 - 0

Item: CR3-G-25

Qty: 1.00

Order Number: B011075 - 1

Material	Qty	U/M	Material Description	Ship Loose
690320...	1.00...	EA...	THERMOCOUPLE PROBE ASSEMBLY	L...
910490	22.00	IN	CCC39201 BLACK PVC WIDE FLEXIBLE TRIM (1800 INCHES PER ROLL)	
910760	12.00	FT	3/8 IN. ALUMINUM TUBE (50 FT. COIL) 5177 K15	L
925020	1.00	EA	ATMR6 6 AMP 600V. CLASS CC NON-MOTOR RAT ED FERRAZ SHAWMUT FUSE	
926140	2.00	EA	ATDR-6 6 AMP FERRAZ-SHAWMUT LOW PEAK DUAL ELEMENT TIME DELAY FUSE	
980030	3.00	EA	1/4 IN. MOD. 740 BALL VALVE W/ SHORT HANDLE NO. 55412	L
C10190	1.00	EA	30E3C C1/2/3 PEDESTAL PLATE	
C10202	2.00	EA	CR1/2/3 PEDESTAL PLATE FILLER	
C10560PCBLUE	2.00	EA	30A145C C3 DAMPER BLADE POWDER COATED	
C10750	1.00	EA	C3 56C FRAME MOTOR PLATE	
C11270	1.00	EA	30B177C C3 BOILER FLANGE	
C11360	1.00	EA	30B179C C3 FILLER BAND	
C13150	1.00	EA	30E29C TRANSFORMER CUTOUT COVER PLATE	
C13451	1.00	EA	90E41C CR3 LIFTING LUG CHANNEL	
C20050	1.00	EA	C3 AIR HOUSING ASSEMBLY 1.5" EXTENSION	
C21112	1.00	EA	30B222 C3G T AP 8.5B 50-#10	
C22110	1.00	EA	30B120C C3 7-5/8" CHOKE ASSEMBLY	
C24030	1.00	EA	30A406C C3 BACK PLATE ASSEMBLY	
C24110	1.00	EA	30E434C C3 PILOT MOUNTING PLATE ASSEMBLY MO9	
C26092	1.00	EA	30B1039C C3/CR3 15S REF 15-3/4	
C80432	2.00	EA	30A227C C3 DAMPER SCREEN PC	
C80590	2.00	EA	30A29 C2/3 DAMPER AXLE	
C95073	1.00	EA	30B118C C3 ST GAS GUN ASSY	
C95301	1.00	EA	C2/3 DAMPER CROSS LINKAGE ASSEMBLY	
E10070	1.00	EA	90C575C 24 X 22 DISPLAY (8) RECT	
E10073	1.00	EA	90C410C 22" PANEL BOX TOP BLANK	
E10074	1.00	EA	24 X 22 SHORT DOOR	
E10480	1.00	EA	90C72C 10 X 9 COVER PLATE	
E10610	2.00	EA	PANEL BOX MOUNTING BRACKET (BURNER)	
E10672	1.00	EA	1/4" HINGE PIN WITH SNAP-RING GROOVE	
E10680	1.00	EA	90C90C PANEL BOX HINGE BOTTOM PIN 1/4"	
E10690	4.00	EA	90C90C PANEL BOX PIN HINGE TUBE 1/4"	
E20020	1.00	EA	90C503C 10 X 9 X 7.5 PANEL BOX ASSEMBLY	
E20080	1.00	EA	90C407C 24 X 22 PANEL BOX ASSEMBLY MAKE EQUAL AMOUNT E10071	
E21001	1.00	EA	6 X 8 X 4 HOFFMAN WITH 1/2" COUPLING	
E80072	1.00	EA	90C409C 24 X 22 CHASSIS PC WHITE	

**SPECIFICATION SHEET**

Date: 7/16/2004

## Submittal For Record

Page 4 of 4

Customer: YORK AIRE S de RL de CV - 36635

Purchase Order: 30025

Job Number: J018750 - 0

Item: CR3-G-25

Qty: 1.00

Order Number: B011075 - 1

Material	Qty	U/M	Material Description	Ship Loose
E80340	1.00	EA	90C163C 10 X 9 CHASSIS PC WHITE	
F20020	1.00	EA	30D14C C3/4 SCANNER PILOT ASSY #30 NAT INCLUDES X04210 ELECTRODE	
M20347	1.00	EA	I1187MC CR3 VARICAM BRACKET ASSEMBLY	
M20431	1.00	EA	90E278C 1-1/2" #68 BALL VALVE CSD-1	
M20435	1.00	EA	90E282C 2" #740 BALL VALVE CSD-1/MASS	
M29003	1.00	EA	90E229C 1.5 X 6 JUNCTION BOX NIPPLE	
M30010	1.00	EA	90X11C CAM LINK ASSY SINGLE C BURNER	
X02040	1.00	EA	1-1/2 STD BLK HALF COUPLING	
X02622	1.00	EA	1/4 BRASS HEX NIPPLE 122-4	
X02677	1.00	EA	3/8 X 1/4 COMP-MP STR 68-64	
X09600	4.00	EA	1/2-13 HEX NUT	
X09659	4.00	EA	1/2 IN. MED. SPLIT LOCK WASHER	
X09695	2.00	EA	10-32X3/8 SKT/BUTTON HD SCREW	
X09750	1.00	EA	3/8-16 U BOLT LIFTING LUG 2 IN. INSIDE DIMENSION BETWEEN LEGS,	
X09795	7.75	IN	173220.05 PREPUNCHED DIN RAIL (2 METER PIECE = 78.74")	
X09910	1.00	EA	2-1/2 SQ SIGHT GLASS	