



BY JOHNSON CONTROLS
PRODUCT DRAWING

NEW RELEASE

Form 155.21-W2 (1209)

**WIRING DIAGRAM
FIELD CONTROL MODIFICATIONS
MODEL YIA CHILLERS (STYLE D)**

CONTRACTOR _____
ORDER NO. _____
YORK CONTRACT NO. _____
YORK ORDER NO. _____

PURCHASER _____
JOB NAME _____
LOCATION _____
ENGINEER _____

REFERENCE DATE _____

APPROVAL DATE _____

CONSTRUCTION DATE _____

JOB DATA:

CHILLER MODEL NO. _____

CHILLER MODEL NO. _____

NO. OF UNITS _____

NO. OF UNITS _____

ENERGY MANAGEMENT SYSTEMS

Chiller design allows for ease of interfacing with Energy Management Systems (EMS). The OptiView™ Control Center includes unit status contacts, provisions for remote control inputs and provisions for remote setpoint reset of leaving chilled liquid temperature and current limit for EMS interfacing.

Five sets of unit status contacts are factory furnished through a field wiring terminal board in the Optiview Control Center. Each set of contacts are single pole, normally open, rated at 5 amperes resistive at 240VAC. Chiller status contacts are provided for unit:

- Remote Mode Ready to Start – See FIG. 3.
- Cycling Shutdown – See FIG. 4.
- Safety Shutdown – See FIG. 5.
- Run (System Operating) – See FIG. 6.
- Anticipatory/Alarm – See FIG. 7.

Four sets of inputs are available to the EMS, allowing for remote control of unit operation. Input device contact rating shall be 5 milliamperes at 115VAC. Field wiring terminal board (TB4) in the OptiView™ Control Center permits connection for the following operations:

- Remote Stop Contacts – See FIG. 8.
- Remote Start Contacts – See FIG. 8.
- Remote/Local Cycling Devices – See FIG. 9.
- Multi-unit sequence – See FIG. 10.

1. The OptiView™ Control Center has a programmable time clock function as a standard feature with holiday capability. This offers one preset automatic Start-Stop per day on a seven day calendar

basis with the ability to program a single additional holiday start and stop time up to a week in advance. Chilled water pump control contacts (see Note 13) are also provided, allowing for efficient automatic operation of the chilled water pump to reduce energy. Two chilled water pump operating modes are available via the CHW PUMP programming dip switch (position 8 of SW1) on the Microboard. With the switch in the OFF position, the chilled water pump operates for 30 seconds prior to chiller start, during chiller operation, coastdown, and LWT cycling shutdowns. With the switch in the ON position, the chilled water pump operates as above plus it operates during MULTI-UNIT and REMOTE/LOCAL cycling shutdowns.

2. The Johnson Controls E-Link Gateway Card may be interfaced with the chiller OptiView™ Control Center to provide unified chiller plant system control. The owners BAS System directly communicates with the OptiView™ Control Center via the E-Link Gateway Card which may be installed in the Control Center. Temperatures, pressures, safety alarms and cycling information known to the OptiView™ Control Center are then available to the owners BAS network for integrated chiller plant control, data logging, and local and remote operator displays. The E-Link Gateway Card also allows the BAS network to start, stop, and reset the chiller's leaving chilled water and remote load setpoints. The E-Link may be configured for BAC-net, MS/TP, Mod-Bus RTU, N2 Metasys and Lonworks network protocols.

IMPORTANT!

READ BEFORE PROCEEDING!

GENERAL SAFETY GUIDELINES

This equipment is a relatively complicated apparatus. During installation, operation, maintenance or service, individuals may be exposed to certain components or conditions including, but not limited to: refrigerants, oils, materials under pressure, rotating components, and both high and low voltage. Each of these items has the potential, if misused or handled improperly, to cause bodily injury or death. It is the obligation and responsibility of operating/service personnel to identify and recognize these inherent hazards, protect themselves, and proceed safely in completing their tasks. Failure to comply with any of these requirements could result in serious damage to the equipment and the property in

which it is situated, as well as severe personal injury or death to themselves and people at the site.

This document is intended for use by owner-authorized operating/service personnel. It is expected that this individual possesses independent training that will enable them to perform their assigned tasks properly and safely. It is essential that, prior to performing any task on this equipment, this individual shall have read and understood this document and any referenced materials. This individual shall also be familiar with and comply with all applicable governmental standards and regulations pertaining to the task in question.

SAFETY SYMBOLS

The following symbols are used in this document to alert the reader to areas of potential hazard:



DANGER indicates an imminently hazardous situation which, if not avoided, will result in death or serious injury.

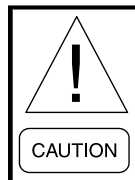

CAUTION identifies a hazard which could lead to damage to the machine, damage to other equipment and/or environmental pollution. Usually an instruction will be given, together with a brief explanation.



WARNING indicates a potentially hazardous situation which, if not avoided, could result in death or serious injury.

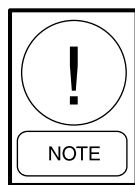

NOTE is used to highlight additional information which may be helpful to you.



External wiring, unless specified as an optional connection in the manufacturer's product line, is NOT to be connected inside the micro panel cabinet. Devices such as relays, switches, transducers and controls may NOT be installed inside the micro panel. NO external wiring is allowed to be run through the micro panel. All wiring must be in accordance with YORK's published specifications and must be performed ONLY by qualified Johnson Controls personnel. Johnson Controls will not be responsible for damages/problems resulting from improper connections to the controls or application of improper control signals. Failure to follow this will void the manufacturer's warranty and cause serious damage to property or injury to persons.

LIST OF FIGURES

FIG. 1 – MICROBOARD (031-02430-005)	4
FIG. 2 – I/O BOARD (031-01743-002)	4
FIG. 3 – REMOTE MODE READY TO START CONTACTS	5
FIG. 4 – CYCLING SHUTDOWN CONTACTS	5
FIG. 5 – SAFETY SHUTDOWN CONTACTS	5
FIG. 6 – RUN CONTACTS	5
FIG. 7 – ANTICIPATORY/ALARM CONTACTS	6
FIG. 8 – REMOTE START AND STOP CONTACTS FROM ENERGY MANAGEMENT SYSTEM	6
FIG. 9 – REMOTE/LOCAL CYCLING DEVICES	6
FIG. 10 – MULTI-UNIT SEQUENCE	7
FIG. 11 – CONDENSER FLOW SENSORS	7
FIG. 11B – PADDLE TYPE FLOW SENSOR	7
FIG. 12 – TWO UNIT SEQUENCE CONTROL	8
FIG. 13 – MULTIPLE UNITS (TWO) - SERIES OPERATION	8
FIG. 14 – MULTIPLE UNITS (TWO) – PARALLEL OPERATION – INDIVIDUAL UNIT PUMPS	9
FIG. 15 – MULTIPLE UNITS (TWO) – PARALLEL OPERATION – SINGLE CHILLED WATER PUMP	9
FIG. 16 – REMOTE STEAM / HOT WATER LIMIT SETPOINT WITH 0-10VDC SIGNAL	10
FIG. 17 – REMOTE STEAM / HOT WATER LIMIT SETPOINT WITH PWM SIGNAL	10
FIG. 18 – REMOTE LEAVING CHILLED LIQUID TEMP. SETPOINT WITH 0-10VDC	11
FIG. 19 – REMOTE LEAVING CHILLED LIQUID TEMPERATURE SETPOINT WITH PWM SIGNAL	12
FIG. 20 – REMOTE LEAVING CHILLED LIQUID TEMP. SETPOINT WITH 0-10VDC	12
FIG. 21 – MICROBOARD DIP SWITCH FOR AUTO/MANUAL RESTART AFTER POWER FAILURE	14
FIG. 20 – EXTERNAL SIGNAL FOR REFRIGERATION UNIT FAILURE	15
FIG. 21 – RUN CONTACTS / REMOTE RUN LIGHT AND SHUTDOWN INDICATOR PLUS EMS	13
FIG. 22 – AUXILIARY SAFETY SHUTDOWN INPUT	13
FIG. 23 – EVAPORATOR FLOW SENSORS	14
FIG. 24 – PADDLE TYPE FLOW SENSOR	14
FIG. 25 – GENERATOR BACKUP TRANSFER	14

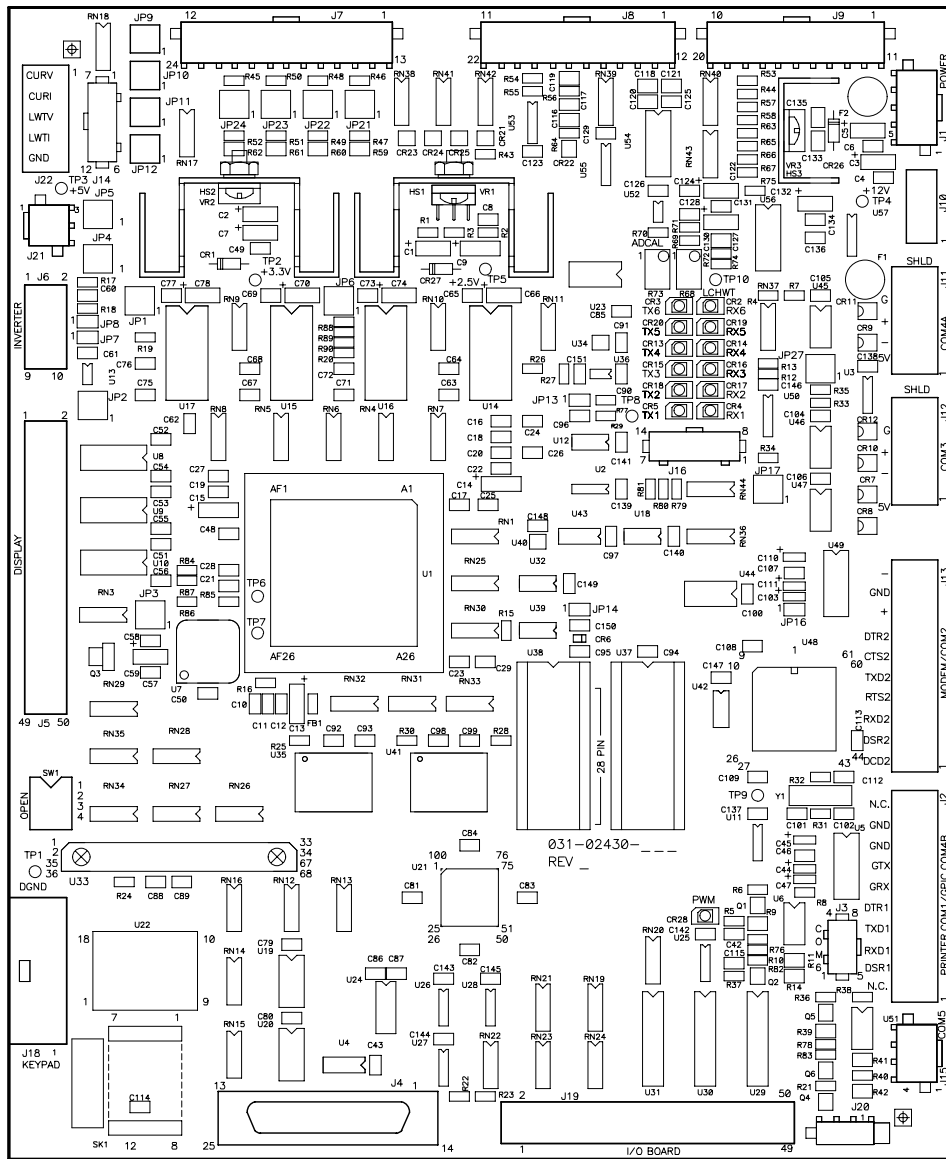

LD14447

FIG. 1 – MICROBOARD (031-02430-005)

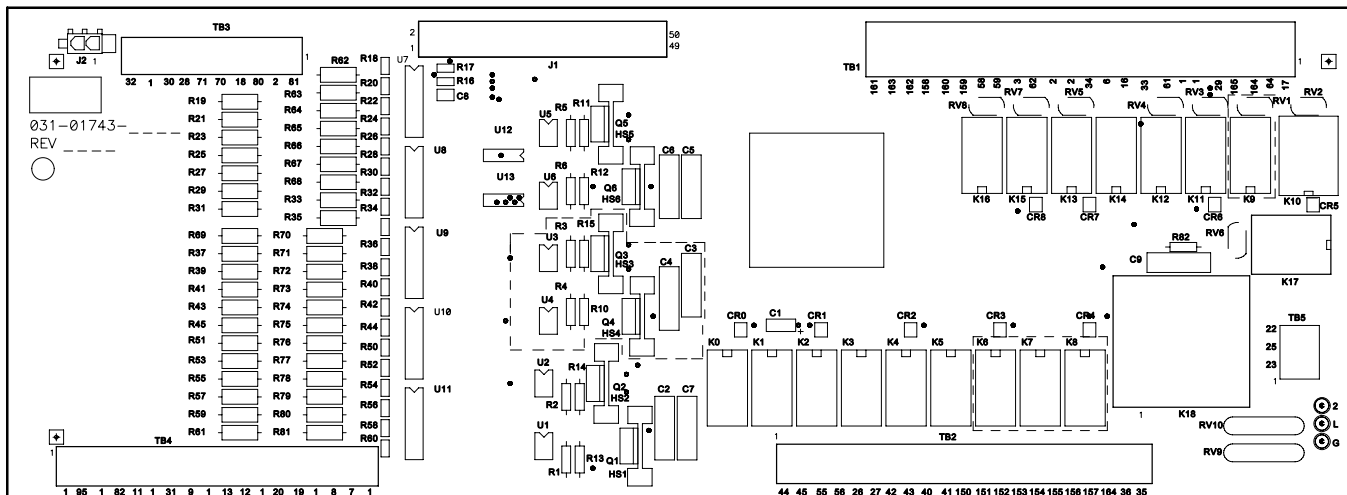
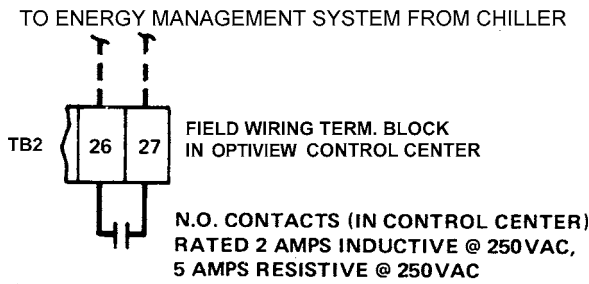

FIG. 2 – I/O BOARD (031-01743-002)

LD06820



LD06820

FIG. 3 – REMOTE MODE READY TO START CONTACTS

REMOTE MODE READY TO START CONTACTS

When closed, these contacts signify the following:

1. The OptiView™ Control Center is in “digital”, “analog” or “ISN” remote operating mode, allowing for energy management system or remote start/stop control (FIG. 8).
2. All chiller safety cutout controls are in the normal position, so they will allow the unit to start.
3. All chiller cycling cutout controls are in the normal position, so they will allow the unit to start.
4. The OptiView Control Center UNIT switch is in the “RUN” (I) position.

TO ENERGY MANAGEMENT SYSTEM FROM CHILLER

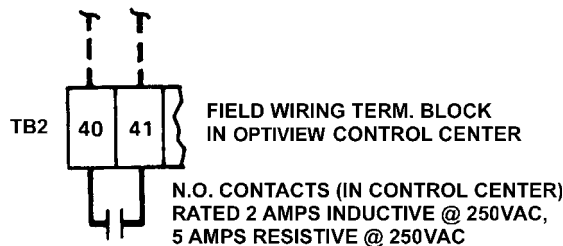

LD06821

FIG. 4 – CYCLING SHUTDOWN CONTACTS

CYCLING SHUTDOWN CONTACTS

When closed, these contacts signify the unit is not permitted to start due to a CYCLING shutdown condition. The unit will automatically restart after the cycling condition is no longer present. YORK Operating and Maintenance Manual 155.21-O1 provides a list and explanation of all Cycling shutdowns. While these contacts are closed, the OptiView™ Control Center will display “CYCLING SHUTDOWN – AUTO RESTART” on the System Status Bar and the cause of the shutdown on the System Details Bar of the display. Cycling Shutdown contacts function in all operating modes.

TO ENERGY MANAGEMENT SYSTEM FROM CHILLER

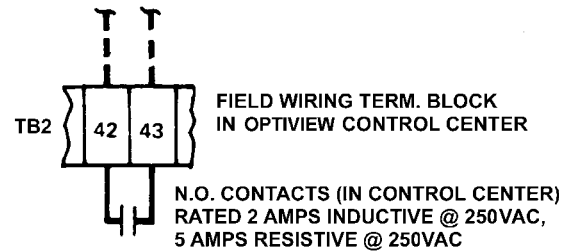

LD06823

FIG. 5 – SAFETY SHUTDOWN CONTACTS

SAFETY SHUTDOWN CONTACTS

When closed, these contacts signify the unit is not permitted to start due to a SAFETY shutdown condition. Safety shutdowns require a manual reset procedure be performed before the unit can be restarted. YORK Operation Manual 155.21-O1 provides a list and explanation of all Safety shutdowns. While these contacts are closed, the OptiView™ Control Center will display “SAFETY SHUTDOWN – RESET TO RESTART” on the System Status Bar and the cause of the shutdown on the System Details Bar of the display. These contacts will remain closed until the safety condition no longer exists and a manual reset is performed by placing the OptiView™ Control Center RUN Switch in the "Stop-Reset" position (O). The unit can then be restarted. Safety Shutdown contacts function in all operating modes.

TO ENERGY MANAGEMENT SYSTEM FROM CHILLER

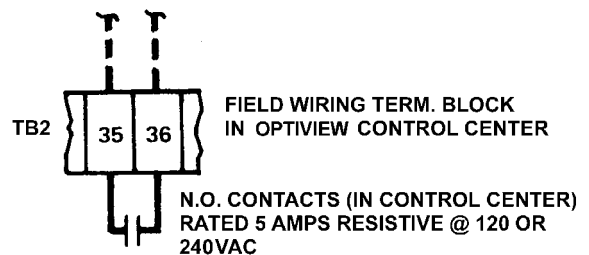

LD06822

FIG. 6 – RUN CONTACTS

RUN CONTACTS

When closed, these contacts signify that the unit is operating. The OptiView™ Control Center will display a System Run Message.

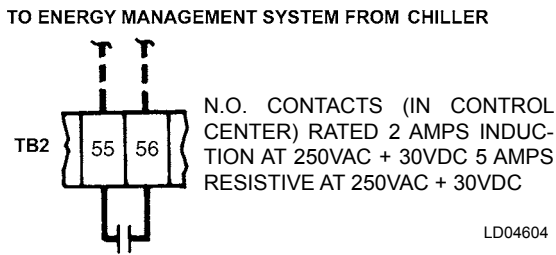

FIG. 7 – ANTICIPATORY/ALARM CONTACTS

ANTICIPATORY/ALARM CONTACTS

These contacts will close whenever one or more of the following WARNING conditions occurs. They will remain closed as long as the condition is in effect. The contacts will open only after the condition is no longer present and the WARNING RESET key is pressed in Operator (or higher) access level.

Low refrigerant temperature in evaporator, generator high pressure, purge pump overloads open, faulty strong solution temperature sensor, high steam supply pressure, high hot water supply temperature, high steam supply temperature, purge pump service recommended, autopurge failure, purge tank pressure is greater than 100mmHg, purge pump OL contacts are in conflict, purge transducer PT4 out of range, 8SOL failure, purge failure, purge pump failure, refrigerant level switch conflict, refrigerant from condenser RT9 or PT1 conflict.

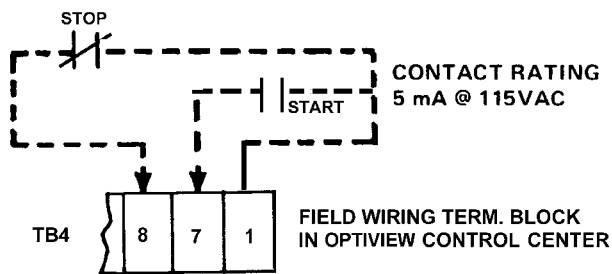

FIG. 8 – REMOTE START-STOP CONTACTS FROM ENERGY MANAGEMENT SYSTEM

REMOTE START AND STOP CONTACTS FROM ENERGY MANAGEMENT SYSTEM

When the OptiView™ Control Center is in the “Digital”, “Analog” or “ISN” remote operating mode and the UNIT switch is in the “RUN” (I) position, with the Remote Stop Contacts open, and the Remote Mode Ready to Start Contacts closed (FIG. 3), the unit will start via a closure of the Remote Start Contacts. A subsequent

closure of the Energy Management System Remote Stop Contacts causes the chiller to shutdown. The OptiView™ Control Center will display “REMOTE STOP” because the Energy Management System Remote Stop Contact has commanded the unit to shutdown.

It is recommended that maintained contacts be used for both START and STOP.

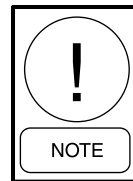

Even when the chiller is applied with Remote Start-Stop (when the Control Center is in the “remote operating mode”), an EMERGENCY STOP by an operator or others can STOP the unit from the OptiView Control Center and prevent the chiller from restarting. However, the operator cannot locally start the unit using “UNIT” start switch, when the control center is in the “remote operating mode”.

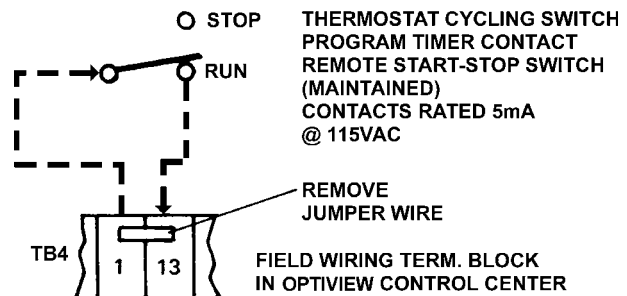
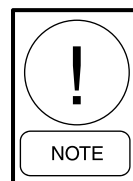

FIG. 9 – REMOTE/LOCAL CYCLING DEVICES

REMOTE/LOCAL CYCLING DEVICES

The closure of an automatic reset device across this input will permit the unit to operate in all operating modes. Conversely, an opening of the device contacts will inhibit the unit from operating; the OptiView™ Control Center will then display the following message “CYCLING SHUTDOWN – AUTO RESTART”.



The OptiView Control Center contains a seven day time clock to select daily schedule Start/Stop times (Sunday through Saturday including one or more holidays in week) up to one full week at a time. So automatic start and stop of the unit on a daily basis, at pre-determined times, can be programmed as a standard feature; an additional program timer is not required for this function.

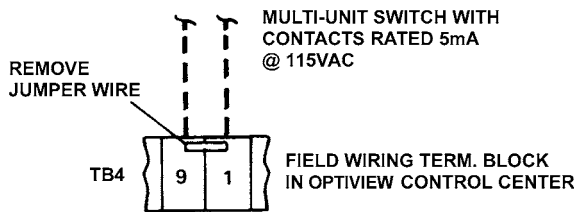

LD06828

FIG. 10 – MULTI-UNIT SEQUENCE

MULTI-UNIT SEQUENCE

For multiple chiller installation application, Multi-Unit Sequence contacts are available to start and stop each unit. The maintained closure of a device contacts across terminals 1 and 9 will permit the unit to operate in all the operating modes with the “UNIT” switch in the “RUN” (I) position. Conversely, an opening of the device contacts will inhibit the unit from operating; the OptiView™ Control Center will then display the following message: “CYCLING SHUTDOWN – AUTO RESTART” and “UNIT SHUTDOWN BY MULTI-UNIT REMOTE”.

CONDENSER FLOW SENSORS

The Thermal-type analog flow sensor interfaces with the Microboard and Paddle-type digital flow sensor interfaces with the I/O board.

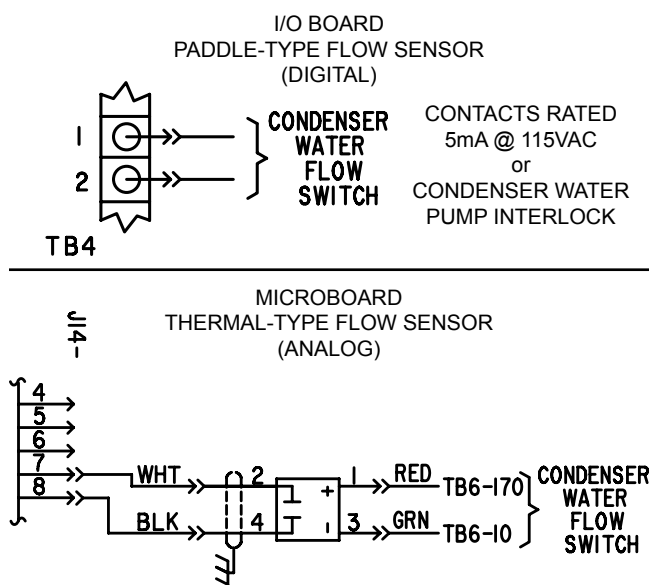

LD14443

FIG. 11 - CONDENSER FLOW SENSORS

The OptiView Control Panel allows the use of either the Thermal-type or Paddle-type flow sensor.

For the program to read the appropriate inputs for the flow sensor status, the actual flow sensor type used must be entered at the keypad SALES ORDER/CONFIG Screen using Service Access Level. Enter "ANALOG" for Thermal-type or "DIGITAL" for paddle type.

When flow is sensed, the flow sensor contacts are closed. Opening of the flow sensor contacts (no flow) for 30 continuous seconds causes a safety shutdown displaying "CONDENSER - WATER FLOW SWITCH OPENED". The flow sensor status is bypassed for the first 30 seconds of "SYSTEM RUN".

THERMAL TYPE FLOW SENSOR

When the Thermal-type flow switch is used, the flow switch uses the cooling effect of liquid to sense flow.

When the flow of liquid is sensed, the solid state relay output is turned on conducting current through the microboard load resistor to the +5VDC applying greater than +4VDC to the microboard input J14-8.

When no flow of liquid is sensed, the solid state relay output is turned off, this results in less than 1VDC to the microboard input and the OptiView Control Center will display the following message: “SAFETY SHUTDOWN ” and “CONDENSER WATER FLOW SWITCH OPEN”.

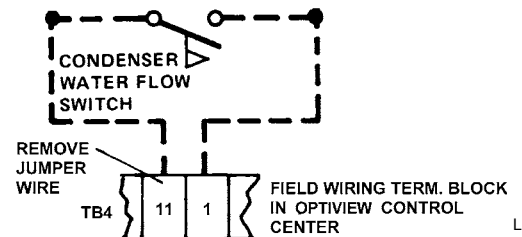

LD06827

FIG. 11B – PADDLE TYPE FLOW SENSOR

PADDLE TYPE FLOW SENSOR

If desired, a condenser water flow interlock can be applied. Flow switch – McDonnell type FS8W, max. 150 psi (YORK Part No. 024-26116) available at additional cost. If condenser water flow switch is not used, a jumper must be installed between terminals 1 and 11.

When condenser water is flowing, the flow switch contact will close. Opening of the condenser water flow switch contacts for 30 continuous seconds will cause unit shutdown. The Flow Switch Status is checked 30 seconds into “System Run” and continuously thereafter. The OptiView Control Center will display the following message: “SAFETY SHUTDOWN” and “CONDENSER WATER FLOW SWITCH OPEN”.

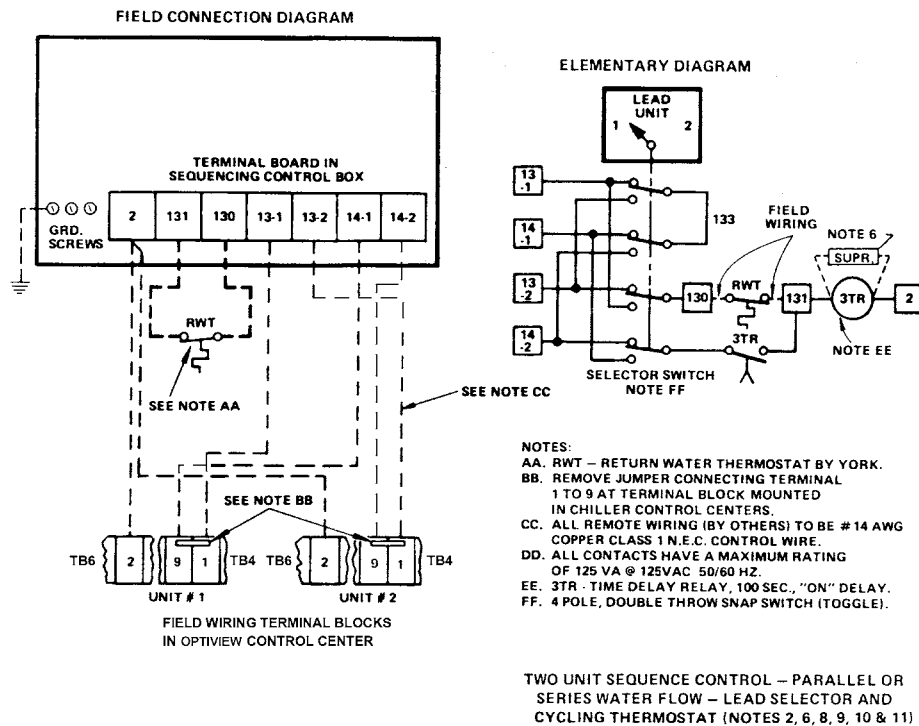
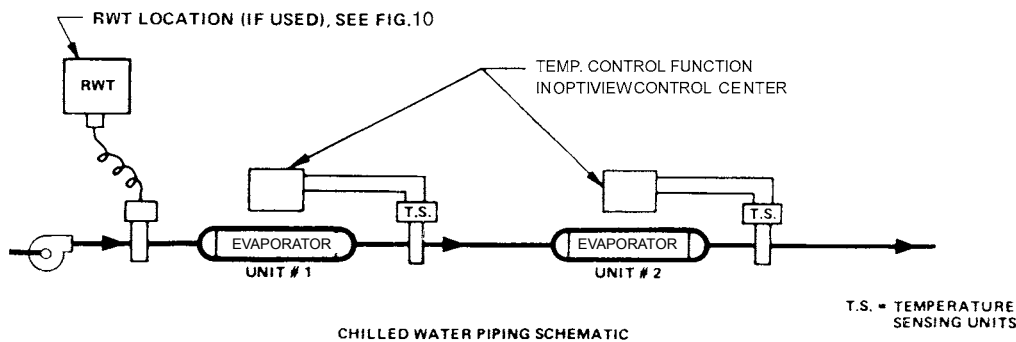

FIG. 12 – TWO UNIT SEQUENCE CONTROL (COOLING APPLICATIONS ONLY)

LD06835



LD06826

FIG. 13 – MULTIPLE UNITS (TWO) – SERIES OPERATION (NOTES 8 & 11)

TWO UNIT SEQUENCE CONTROL

Provides that cycling thermostat RWT will automatically cycle either #1 or #2 unit. Timer 3TR is an additional feature which prevents simultaneous starting of lead and lag unit following a power failure and eliminates nuisance starting of lag unit due to periodic fluctuations in temperature. For two unit sequence control kit, order YORK Accessory Kit No. 466-61597T for controls as specified with NEMA 1 enclosure.

RWT has 20°F to 80°F range with adjustable differential of 3-1/2 to 14°F; 6 ft. of capillary with 3/8" x 5" bulb and 1/2" NPT brass well (maximum liquid DWP 300 PSIG). The thermostat is drawn to indicate its operation closes on rise. A 1/2" pipe coupling in the return chilled water line from the building must be furnished (by others) for RWT control well.

MULTIPLE UNITS (TWO) - SERIES OPERATION

The supply chilled water temperature to the building is normally determined by the chilled liquid temperature setpoint for Unit #2. When lead selector position of sequence control kit (FIG. 12) is Unit #1, the supply chilled water temperature to the building will be the temperature control setpoint on Unit #1 OptiView™ Control Center. If lower temperature is desired, reprogram the chilled liquid temperature setpoint for Unit #1.

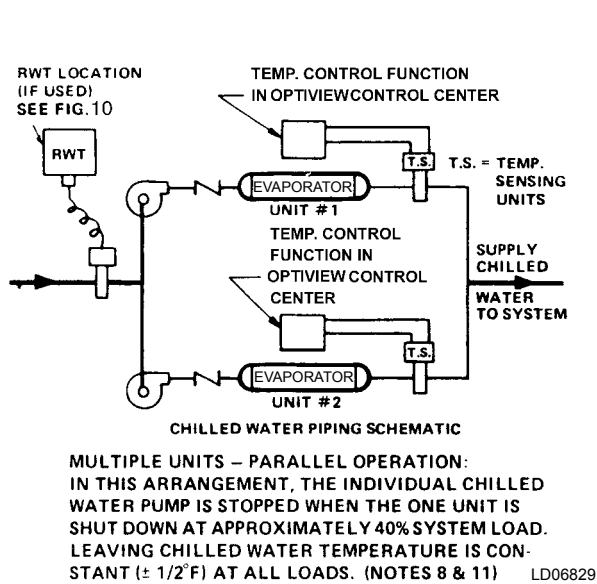

FIG. 14 – MULTIPLE UNITS (TWO) – PARALLEL OPERATION – INDIVIDUAL UNIT PUMPS (COOLING APPLICATION ONLY)

MULTIPLE UNITS (TWO) – PARALLEL OPERATION – INDIVIDUAL UNIT PUMPS

This piping arrangement is the same as FIG. 15, except that the chilled water pumps associated with each evaporator are cycled ON and OFF with the unit. This results in reduced chilled water flow rates whenever a single unit can handle the cooling load. Because no chilled water flows through the inoperative unit, the mixed water temperature peculiar to using a single pump is avoided. When one unit is cut-out by the sequence control (FIG. 12) the temperature of the supply chilled water does not change.

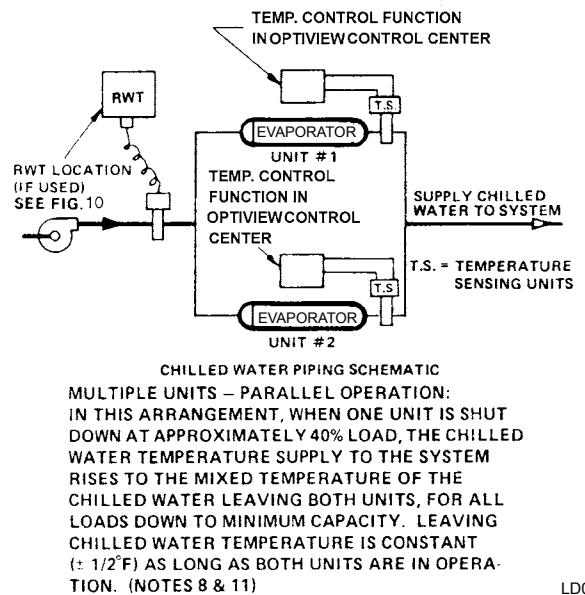

FIG. 15 – MULTIPLE UNITS (TWO) – PARALLEL OPERATION – SINGLE CHILLED WATER PUMP (COOLING APPLICATION ONLY)

MULTIPLE UNITS (TWO) – PARALLEL OPERATION – SINGLE CHILLED WATER PUMP

For this piping arrangement, each chiller’s water sensor is located in its own leaving water nozzle. This produces a constant “mixed” chilled water temperature when both units are operating. When either unit is cycled off by the sequence control (FIG. 12), mixed chilled water temperature will rise as a result of uncooled return water flowing through the inoperative unit. For individual unit chilled water pump piping, refer to FIG. 14.



Important! The signal type used for Remote Leaving Chilled Liquid Temperature setpoint and Remote Steam/Hot Water Limit Setpoint must be the same. Do NOT use an analog signal for one and PMM for another.

REMOTE STEAM/HOT WATER LIMIT SETPOINT (CONTROL SIGNAL; ANALOG, 0-10VDC)

The Remote Steam/Hot Water Limit setpoint limits the control valve position which in turn controls the top end capacity of the unit. The control valve can be remotely set between the ranges of 10% to 100% by supplying (by others) a 0-10VDC signal to the OptiView control center.

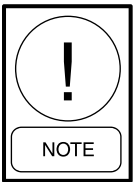

Any locally programmed settings will take precedence over the remote settings. For example, if the Maximum load limit value is programmed locally for 80% and the remote value is set at 100%, the unit will be limited at the 80% valve position.

The OptiView control center must be configured appropriately to accept the desired signal type as follows:

- The appropriate signal source mode must be selected. It is recommended that a qualified YORK/Johnson Controls service technician accomplish this in the local/service mode on the OptiView control center. Analog mode must be selected when using a 0-10 voltage.
- Microboard program jumper JP23 must be removed to accept the analog signal. It is recommended that a qualified YORK/Johnson Controls service technician position this jumper.

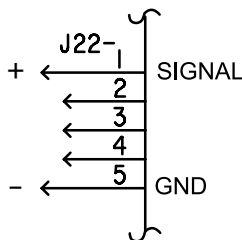

LD14444

FIG. 16 – REMOTE STEAM / HOT WATER LIMIT SETPOINT WITH 0-10VDC SIGNAL

As shown above, connect the input to microboard J22-1 (signal) and J22-5 (ground). The setpoint varies valve position linearly from 100% to 10% as the input varies from 0-10 VDC. Calculate the setpoint for various inputs as follows:

$$\text{SETPOINT (\%)} = 100 - (\text{VDC} \times 9)$$

Example, if the input is 3VDC, the setpoint would be set to 73% as follows;

$$\text{SETPOINT (\%)} = 100 - (3 \times 9) = 100 - 27 = 73\%$$

REMOTE STEAM/HOT WATER LIMIT SETPOINT (CONTROL SIGNAL; DIGITAL, PWM)

The Remote Steam/Hot Water Limit setpoint limits the control valve position which in turn controls the top end capacity of the unit. The control valve can be remotely set between the ranges of 10% to 100% by supplying (by others) a 1 to 11 second PWM relay contact closure. The OptiView control center must be configured appropriately to accept the desired signal type as follows:

- The appropriate signal source mode must be selected. It is recommended that a qualified YORK/Johnson Controls service technician accomplish this in the local/service mode on the OptiView control center. Digital mode must be selected when using a 1- 11 PWM signal with contacts rated 5mA @ 115VAC.

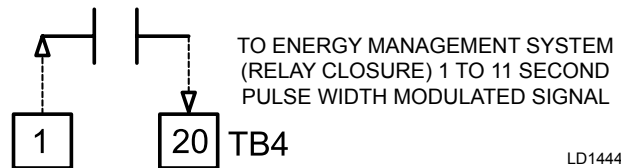

LD14445

FIG. 17 – REMOTE STEAM / HOT WATER LIMIT SETPOINT WITH PWM SIGNAL

As shown above, 115VAC is applied to the I/O board TB4-20 for 1 to 11 seconds. Connect dry closure relay contacts between I/O board TB4-20 (signal) and TB4-1 (115VAC). The setpoint varies valve position linearly from 100% to 10% as the relay contacts closure time changes from 1 to 11 seconds. The pulse time is receivable in 0.1 second time periods (0.1 seconds = 1%). The relay contact should close for 1 to 11 seconds at least once every 30 minutes to maintain the setpoint to the desired value. If a 1 to 11 second closure is not received within 30 minutes of the last closure, the setpoint is defaulted to 100%. Figure setpoint below:

$$\text{PWM \%} = (\text{seconds} - 1) \times 10$$

Therefore, a 2 second pulse = 10%, 3 sec = 20%, 4 sec = 30% up to 11 sec which will = 100%

Calculate the setpoint for various pulse widths as follows:

$$\text{SETPOINT (\%)} = 100 - (\text{PWM\%} \times 0.9)$$

Example; if the PWM is 5 seconds, the setpoint would be set to as follows:

$$\text{PWM \%} = (5 - 1) \times 10 = 40\%$$

$$\text{SETPOINT (\%)} = 100 - (40 \times .9) = 100 - 36 = 64\%$$

The maximum rate at which the OptiView control panel will accept Remote Steam/Hot Water Limit setpoint pulses is one pulse each 60 seconds. Following a remote setpoint pulse, the Steam/Hot Water Limit setpoint changes to the value corresponding to the pulse-width. If a second reset pulse is not received within 30 minutes of the first pulse, the Steam/Hot Water setpoint reverts to the programmed maximum load limit setpoint. If the “Pull-down Demand Limit” has been programmed and the unit was started and has run less than the Pull-down Demand Limit Timer setpoint, then the unit will be steam/hot water limited by the lower of the Pull-down Demand Limit and the Remote Steam/Hot Water Limit. The Pull-down Demand Limit will automatically transfer control of Steam/Hot Water Limit function to “REMOTE” at the end of its programmed timed cycle with the unit in the "REMOTE" mode.

REMOTE LEAVING CHILLED LIQUID TEMPERATURE SETPOINT

Remote Leaving Chiller Liquid Temperature setpoint allows an operator to change the leaving chilled liquid temperature from a remote location. Before this can be accomplished the “Remote Reset Range” must be set-up locally on the OptiView panel by a qualified YORK/Johnson Controls service technician. This parameter is the maximum allowable offset of the leaving chilled liquid setpoint when operating in the Remote mode. This offset is either 10°F or 20°F as programmed. If not programmed, the default value is 20°F. This value is added to the operator programmed “Leaving Chilled Liquid Temperature Setpoint” (base) and the sum equal the temperature range in which the setpoint can be reset. For example, if the operator has locally programmed a setpoint for 44°F (base) into the OptiView control center, and the “Remote Reset Range” is programmed to be 10°F, then the energy management system can remotely reset the setpoint over the range of 44°F to 54°F ($44 + 10 = 54$).

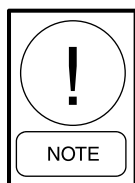

The Remote Leaving Chilled Liquid Temperature setpoint cannot be set lower than the base setpoint value. The base or locally programmed setpoint is always shown in the “Local LCHLT Setpoint” box in the lower left corner of the Evaporator / Absorber screen.

REMOTE LEAVING CHILLED LIQUID TEMPERATURE SETPOINT (CONTROL SIGNAL; ANALOG, 0-10VDC)

Remote Leaving Chilled Liquid Temperature setpoint can be accomplished by supplying (by others) a constant 0-10VDC signal to the OptiView control center. The Leaving Chilled Liquid Temperature setpoint is programmable over the range of 40°F to 97°F (if Remote Reset Range is 20) otherwise 87°F will be the top end of the range. The OptiView control center must be configured appropriately to accept the desired signal as follows:

- The appropriate signal source mode must be selected. It is recommended that a qualified YORK/Johnson Controls service technician accomplish this in the local/service mode on the OptiView control center. Analog mode must be selected when using a 0-10 voltage.
- Microboard program jumper JP24 must be removed to accept the analog signal. It is recommended that a qualified YORK/Johnson Controls service technician position this jumper.

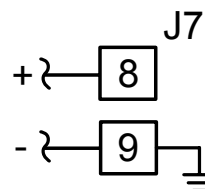

LD14446

FIG. 18 – REMOTE LEAVING CHILLED LIQUID TEMPERATURE SETPOINT WITH 0-10VDC SIGNAL

As shown above, connect the input to microboard J7-8 (signal) and J7-9 (ground). The leaving chilled water can then be changed remotely. It cannot be changed lower than the locally set (base) setpoint nor can it go any higher than the remote reset range value. If the OptiView panel is taken out of analog mode for any reason, the setpoint will revert back to the locally programmed setpoint.

REMOTE LEAVING CHILLED LIQUID TEMPERATURE SETPOINT (CONTROL SIGNAL; DIGITAL, PWM)

The pulse width modulation input is in the form of a 1 to 11 second contact closure that applies 115VAC across I/O board terminals TB4-1 (115VAC) and TB4-19 (input) for 1 – 11 seconds. A contact closure time (pulse width) of 1 second produces a 0°F offset. An 11 second closure produces the maximum allowed offset (10 to 20°F) above the local setpoint value. The relay contacts should close for 1 to 11 seconds at least once every 30 minutes to maintain the setpoint to the desired value. If the 1 to 11 second closure is not received within 30 minutes of the last closure, the setpoint is defaulted to the local setpoint value. The maximum rate at which the OptiView control panel will accept a remote PWM signal is one pulse each 60 seconds. The OptiView control center must be configured appropriately to accept the desired signal as follows:

- The appropriate signal source mode must be selected. It is recommended that a qualified YORK/Johnson Controls service technician accomplish this in the local/service mode on the OptiView control center. Digital mode must be selected when using a 1- 11 pulse width modulated signal with contacts rated 5mA @ 115VAC. Figure setpoint below;

$$\text{OFFSET (°F)} = \frac{(\text{PULSE WIDTH IN SECONDS}) (\text{REMOTE RESET TEMP. RANGE})}{10}$$

$$\text{SETPOINT (°F)} = \text{LOCAL SETPOINT} + \text{OFFSET}$$

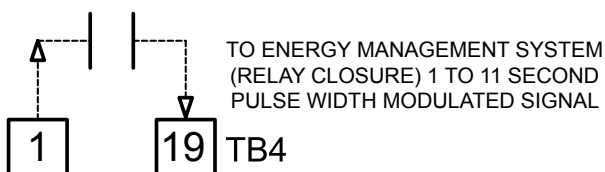

LD14447

FIG. 19 – REMOTE LEAVING CHILLED LIQUID TEMPERATURE SETPOINT WITH PWM SIGNAL

For example, if the relay contacts close for 5 seconds and the Remote Reset Range setpoint is for 10°F, and the local Leaving Chilled Liquid Temperature Setpoint is programmed for 40°F; the setpoint would be set to 44°F as follows:

$$\text{OFFSET (°F)} = (5-1) (10) / 10 = (4) (10) / 10 = 40/10 = 4^\circ\text{F}$$

$$\text{SETPOINT (°F)} = 40 + 4 = 44^\circ\text{F}$$

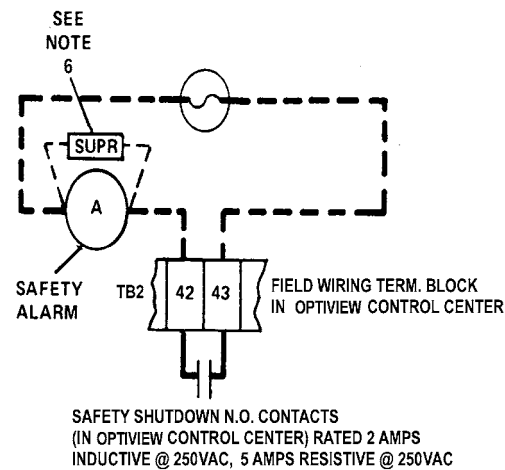

FIG. 20 – EXTERNAL SIGNAL FOR REFRIGERATION UNIT FAILURE (NOTE 6)

EXTERNAL SIGNAL FOR REFRIGERATION UNIT FAILURE

When the Safety Shutdown Contacts (see FIG. 5) are not connected to an Energy Management System they may be employed to energize a local or remote safety alarm (by others). When the normally open Safety Shutdown Contacts close, the alarm will indicate shutdown of the unit. The cause of shutdown will be one or more of the following safety controls:

- Solution or refrigerant pump overloads or thermal switches tripped/open.
- Low refrigerant temperature cut-out.
- Generator high pressure cut-out.
- Generator high pressure cut-out.
- Steam / Hot water high temperature cut-out.
- Steam supply pressure (Steam unit only) cut-out at 35.0 PSIA.
- Power failure.
- Chilled water flow switch open.
- Following a power failure, if the solution temperature is less than 136°F when power is resored and the unit did not complete its previous dilution cycle, check for crystallization.
- If, after a shutdown as described in item (1), while the solution or refrigerant pump overloads or thermal switches are tripped, if the solution temperature falls to less than 136°F before the switches re-close, check for crystallization.
- While the low refrigerant cut-out switch is tripped or the refrigerant temperature sensor temperature rises to 37°F (whichever device caused the shutdown), if the solution temperature is less than 136°F, check for crystallization.

12. While the chilled water flow switch is tripped after shutdown as described in item (8) and the solution temperature is below 136°F, check for crystallization.
13. While the condenser water flow is tripped/open; if the solution temperature falls to less than 136°F, check for crystallization.

When all safety controls are satisfied, and the OptiView control center "unit" switch has been placed in the "STOP/RESET" position, (de-energizing the alarm) and then in the "RUN" position, the unit may be restarted, if the control center is in "REMOTE" mode, via the Remote Start Contacts (FIG. 8); or if the control center is in "local" mode the unit may be started by pressing the keypad-mounted "unit" switch to the "START" position.

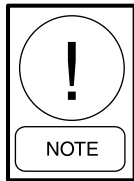

If the unit was shut down because of Cycling Shutdown Contacts (see FIG. 4) the alarm will not be energized, but the unit will have been shut down. A closure of the safety alarm contacts means that an operator must manually reset and restart the unit.

When the Safety Shutdown contacts close, the OptiView™ Control Center will display the following message: "SAFETY SHUTDOWN – MANUAL RESTART", and the cause of shutdown.

ELEMENTARY DIAGRAM

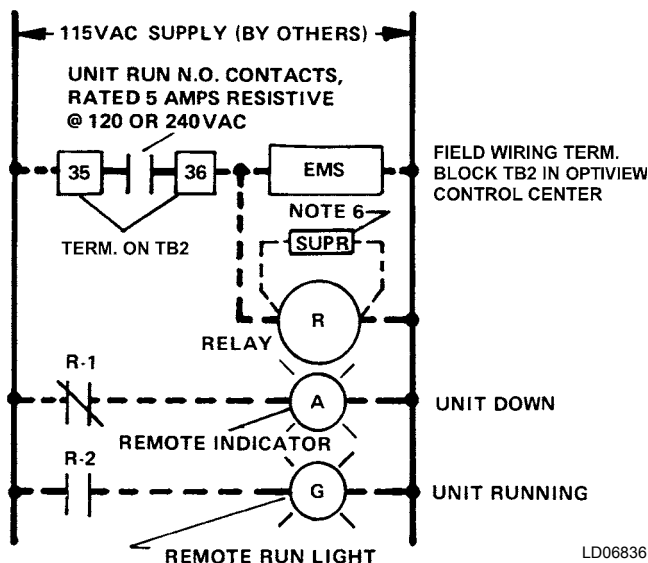

FIG. 21 – RUN CONTACTS / REMOTE RUN LIGHT AND SHUTDOWN INDICATOR PLUS EMS

RUN CONTACTS/REMOTE RUN LIGHT AND SHUTDOWN INDICATOR PLUS EMS

When run contacts are required for a Remote Run Light and/or Shutdown Indicator AND Energy Management System (EMS), connect (by others) as shown in the diagram. The EMS, control relay, shutdown and run lights are furnished by others. When the N.O. contacts close, between terminals 35 and 36 on field wiring terminal block TB2 in the OptiView Control Center, this indicates that the unit is operating; the Remote Run Light will be energized. The unit run contacts open when the unit is shutdown (safety or cycling) and the remote indicator will then be energized. For run contacts to EMS only refer to FIG. 6. When terminals 35 and 36 are not used for an EMS, they may be connected to a remote Run Light. The control relay scheme shown in FIG. 21 can also be applied for a Remote Run Light and a Remote Shutdown Indicator, when an EMS is not used.

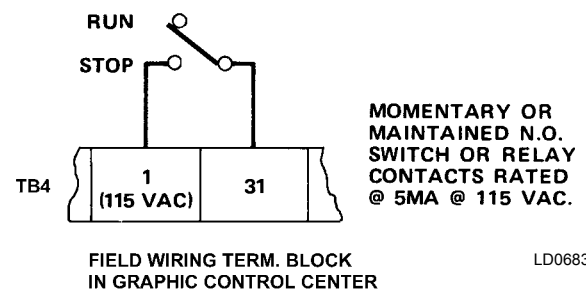

FIG. 22 – AUXILIARY SAFETY SHUTDOWN INPUT

The closure of a momentary or maintained N.O. Switch or Relay Contacts will cause the unit to shut down and display: system status - "RESET TO RESTART" and under fault message - "AUXILLIARY SAFETY SHUT-DOWN". The unit will not restart until the contacts open and the keypad "unit" switch is moved to the "STOP/RESET" position and then to the "START" position.

EVAPORATOR FLOW SENSORS

The Thermal-type flow sensor interfaces with the Microboard and Paddle-type flow sensor interfaces with the I/O board.

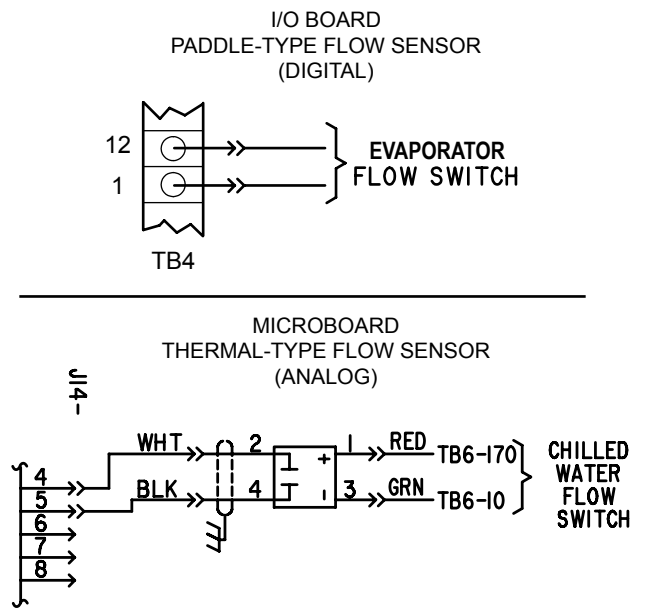

FIG. 23 - EVAPORATOR FLOW SENSORS

Flash Memory Card Version C.OPT.15.01.XXX and later allows the use of either the Thermal-type or Paddle-type flow sensors on the Style D and later chillers.

For the program to read the appropriate inputs for the flow sensor status, the actual flow sensor type used must be entered at the keypad SALES ORDER/CONFIG Screen using SERVICE access level. Enter "ANALOG" for Thermal-type or "DIGITAL" for Paddle-type.

When flow is sensed, the flow sensor contacts are closed. Opening of the flow sensor contacts (no flow) for 2 continuous seconds causes a cycling shutdown displaying "CHILLED LIQUID FLOW SWITCH OPENED".

THERMAL TYPE FLOW SENSOR

When the Thermal-type flow switch is used, the flow switch uses the cooling effect of liquid to sense flow.

When the flow of liquid is sensed, the relay output is turned on conducting current through the microboard load resistor to the +5VDC applying greater than +4VDC to the microboard input J14-5.

When no flow of liquid is sensed, the relay output is turned off, this results in less than 1VDC to the microboard input.

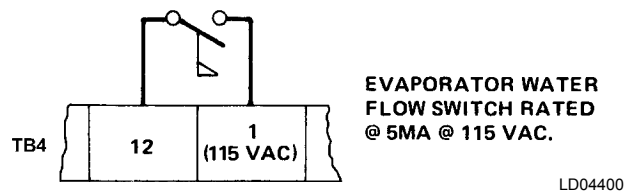

FIG. 24 – PADDLE TYPE FLOW SENSOR

PADDLE TYPE FLOW SENSOR

When Evaporator Water is flowing, the flow switch contact will close. If the flow switch opens for 2 seconds, the unit shuts down.

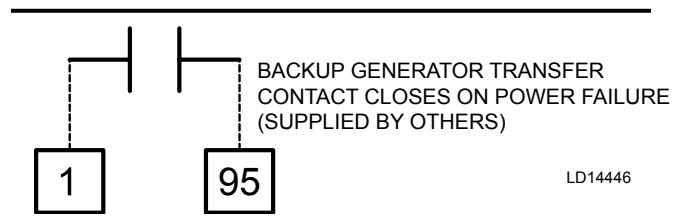

FIG. 25 – GENERATOR BACK-UP TRANSFER

GENERATOR BACKUP TRANSFER

During a prolonged power failure the unit will shutdown without going through a dilution cycle. This could cause the unit to crystallize depending on the duration of power failure. By adding a small standby AC 3-phase power supply, the solution pump can perform a limited dilution cycle.

During a power failure a subsequent limited dilution cycle, the system will NOT be able to produce chilled water.

If unit experiences a power failure, the input (95) on the I/O board is checked for a closed contact (indicating that a standby power supply is online). No matter what the solution concentration is at the time of the power failure or what the dilution cycle to last NO longer than 4 hours. The generator will supply power to the unit mounted power panel, which will supply OptiView control panel and solution pump for the dilution period. During this period, the unit will continue to monitor if the fault condition has been cleared to switch to a normal dilution cycle. If condenser flow is sensed through the flow switch during the limited dilution cycle, the dilution cycle will cease.

Refer to 155.21-O1 for additional details on the limited dilution cycle.

Refer to 155.21-EG1 for minimum power requirements for standby power supply.

DOWNLOADING HISTORIES TO A LAPTOP FROM AN OPTIVIEW CONTROL CENTER

Refer to details explained in FORM 155.21-O1.

NOTES

1. This drawing shows recommended field control wiring modifications (by others) to the standard OptiView™ Control Center Wiring Diagram. For additional single stage YIA OptiView wiring details see Form 155.21-W1.
2. If more than one of these modifications is to be utilized with a particular unit, additional consideration must be given to the application to insure proper functioning of the control system. Consult your YORK/Johnson Controls representative.
3. The additional controls and wiring for these modifications are to be furnished and installed in the field (by others) (see Warnings on page 2).
4. The controls specified are recommended for use, but other controls of equal specifications are acceptable.
5. All wiring shall be in accordance with the National Electrical Code, and applicable State and Local Codes.
6. Each 115VAC field connected inductive load, i.e. relay coil, motor starter coil, etc., shall have a transient suppressor wired (by others) in parallel with its coil, physically located at the coil. Spare transient suppressors are furnished in a bag in the OptiView™ Control Center.
7. The OptiView™ Control Center is factory furnished for Manual Restart After Power Failure as a standard function. The control center can be field changed from Manual restart to Auto restart after a power failure. For details consult a qualified YORK/Johnson Controls service technician.
8. Two (2) unit controls schemes are suitable for 8° – 12°F water range. Constant chilled water flow is assumed at all loads. For other requirements contact your YORK/Johnson Controls representative.
10. Lead selector and cycling control to provide similar lead selection and cycling of lag units for three (3) units is available: Kit No. 366-44684D in NEMA I enclosure. Consult your YORK/Johnson Controls representative.
11. Sequence control kits (see FIG's 12, 13 and Note 10) assume a constant chilled water flow and a constant leaving chilled water temperature to sense the cooling load. Sequence control kits are not designed for variable chilled water flow or with reset of the leaving chilled water temperature (see FIGs. 18 to 20 and Note 2).
12. Maximum allowable current draw between circuits for field installed devices is 2 amp holding and 10 amps inrush (see OptiView™ Control Center Wiring Diagram Form 155.21-W1).
13. For required field wiring connections of the chilled water pump contacts (terminals 44 and 45) on OptiView™ Control Center field wiring terminal block TB2) and chilled water flow switch (terminals 1 and 2) on OptiView™ Control Center field wiring terminal board (see Wiring Diagram Form 155.21-W1).
The chilled water flow switch is a safety control. It must be connected to prevent operation of the chiller whenever chilled water flow is stopped. The use of the chilled water flow switch for purposes other than protection of the chiller may be accomplished in several ways. Two flow switches, a flow switch and a relay or separate contacts on the same flow switch.
15. Do not apply voltage on field wiring terminal blocks TB4 and TB6 in YORK OptiView™ Control Center, as 115VAC source is fed from terminals 1 and 2.
16. Entering and Leaving Chilled and Condenser Water Temperature Sensors are supplied by YORK as a standard item on all YIA units.



BY JOHNSON CONTROLS

P.O. Box 1592, York, Pennsylvania USA 17405-1592
Copyright © by Johnson Controls Inc. 2009

Tele. 800-861-1001
www.york.com

Subject to change without notice. Printed in USA
ALL RIGHTS RESERVED

Form 155.21-W2 (1209)
NEW RELEASE