



ABSORPTION WELDING INSTRUCTIONS

SERVICE

Supersedes: 155.17-M3 (694)

Form 155.17-M3 (204)

MAJOR CUTTING AND WELDING GUIDELINES

NO CUTTING TORCHES



Oxy-Acetylene cutting torches will blow molten metal particles into the unit. Some of these will adhere to the the copper alloy tube surfaces causing pitting corrosion to occur later. The loose particles will plug spray nozzles and cause pump bearing failures.

Hole saws, reciprocating saws or the like should be used whenever possible. The preferred method of entry at YORK's manufacturing facilities is to *skim gouge* or air-arc the metal so that only a thin skin of metal remains and then to grind the metal away using a disk grinder. Final grinding is done with a slight positive pressure in the unit so that grinding residue does not fall into the unit. Any entry method should be performed with a slight positive pressure in the unit so that all cutting debris is blown outward. See Cutting Details section for more specific information.

NEVER LEAVE THE UNIT OPEN TO THE ATMOSPHERE

Keep a constant purge of Nitrogen or Argon on the unit when it is open. Tightly tape any openings with plastic or use test plugs to close openings. If a unit has to be cut apart for installation purposes, weld temporary closures over the openings. Evacuate the unit as soon as possible

after temporary closures have been welded on to remove air and recharge with a slight positive charge of Nitrogen or Argon. A small hole can be made with a pencil point in the plastic to provide a positive purge of nitrogen. Set the regulator for only a small flow (detectable on a wet wrist) and insure that the Nitrogen or Argon bottle has a sufficient quantity of gas remaining if the unit will be left unattended. If necessary, manifold several bottles of inert gas together. If available, a liquid nitrogen bottle will supply a sufficient quantity of gas to last for long periods of time.

FIRST AND SECOND PASS (ROOT AND HOT PASS) MUST BE TIG WELDED.

Stick welding is not allowed on the first pass due to the need for a smooth internal weld surface. Chill rings or backup rings are not allowed due to the crevice they will provide for corrosion to occur. See Welding Details section for more specific welding information.

ALL CUTTING AND WELDING OF UNITS UNDER WARRANTY MUST BE 100% YORK SUPERVISED.

Under no circumstances should non-YORK personnel be given sole responsibility to cut or weld on a YORK Absorption unit. Absorption units require specialized handling when cutting or welding. Only trained YORK personnel are considered qualified to supervise or perform this work.

CUTTING DETAILS

1. Cutting into a YORK Absorption unit should only be done after careful study of assembly drawings. Precautions should be taken to avoid damaging internal items in the unit such as tubes, etc. Complete removal of solution or refrigerant may be required to avoid loss of Lithium Bromide.
2. Whenever possible, use circular hole saws or reciprocating saws to cut access holes. Do not use cutting torches. Where extensive cutting is necessary, skim gouge (See Gouging Procedure) until only a thin layer of metal remains, then grind that metal away using a disk grinder. Be sure a slight positive pressure remains in the unit during this operation.
3. Keep a slight positive pressure on the unit at all times so that cutting dirt and air does not enter the unit.
4. If major repairs are necessary, it may be beneficial to perform a Lithium Hydroxide wash first. Consult YORK Factory Service prior to this procedure.

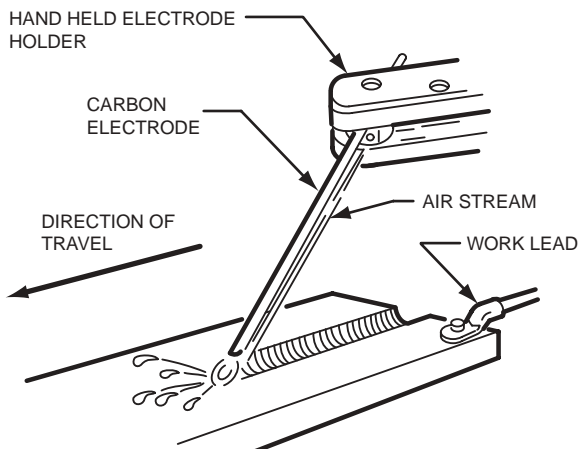

FIG. 1 - SKIM GOUGING

LD09443

GOUGING

Air carbon arc gouging is an arc gouging process in which metals to be gouged are melted by the heat of a carbon arc and the molten metal is removed by a blast of air. A high velocity air jet traveling parallel to carbon electrode strikes the molten metal puddle just behind the arc and blows the molten metal out of the immediate area. Fig. 1 shows the operation of the process. It shows the arc between the carbon electrode and the work and the air stream parallel to the electrode coming from the special electrode holder.

The air carbon arc cutting process can also be used to cut metal and to gouge out defective metal, to remove old or inferior welds, for root gouging of full penetration welds, and to prepare grooves for welding. Air carbon arc cutting is used when slightly ragged edges are not objectionable. The area of the cut is small, and since the metal is melted and removed quickly, the surrounding area does not reach high temperatures. This reduces the tendency towards distortion and cracking. The air carbon arc cutting process can be used in all positions. It can also be used for gouging in all positions. Use in the overhead position requires a high degree of skill.

The electrode holder is designed for the air carbon arc process. The electrode holder and a copper coated electrode are shown in Fig 1. The holder includes a small circular grip head which contains the air jets for directing the compressed air along the electrode. It also has a groove for gripping the electrode. This head can be rotated to allow different angles of electrode with respect to the holder. A heavy electrical lead and an air supply hose are connected to the holder through a terminal block. A valve is included in the holder for turning the compressed air on and off. Holders are available in several sizes depending on the duty cycle of the work performed, the welding current and the size

of carbon electrode used. For extra heavy duty work water cooled holders are used.

The air pressure is not critical but should range from 80 to 100 psi (550 to 690 kPa). The volume of compressed air required ranges from as low as 5 cu ft/min (2.5 liter/min) to 50 cu ft/min (24 liter/min) for the largest size electrodes. A one horsepower compressor will supply sufficient air for smaller size electrodes. It will require up to a ten-horsepower compressor when using the largest size electrodes.

The carbon graphite electrodes are made of a mixture of carbon and graphite plus a binder which is baked to produce a homogeneous structure. Electrodes come in several types. The plain uncoated electrode is less expensive, carries less current and starts easier. The copper coated electrode provides better electrical conductivity between it and the holder. The copper coated electrode is better for maintaining the original diameter during operation; it lasts longer and carries a higher current. Copper electrodes are of two types, the DC type and the AC type. The composition ratio of the carbon and graphite is slightly different for these two types. The DC type is more common. The AC type electrode contains special elements to stabilize the arc. The AC type electrode is used for direct current electrode negative when cutting cast irons. For normal use, the electrode is operated with the electrode positive. Electrodes range in diameter from 5/32 in (4.0 mm) to 1 in (25.4 mm). To make a cut or a gouging operation the cutter strikes an arc and almost immediately starts the air flow. The electrode is pointed in the direction of travel with a push angle approximately 45 degrees with the axis of the groove. See the following Carbon Arc Gouging Procedure (Air Arc) WPS No. 135-015-001 for the prescribed procedure.

The speed of travel, the electrode angle and the electrode size and current determine the groove depth. Electrode diameter determines the groove width. See Table 2 for specific details.



Carbon Arc Gouging is a very noisy process and ear protection should be worn.



Carbon Arc Gouging creates large amounts of molten metal that will be falling in the surrounding area. Combustible materials and personnel should be suitably protected.

**CARBON ARC GOUGING PROCEDURE
(AIR ARC) WPS NO. 135-015-001**

Arcair Manual Torch K-3 and K-5

The Arcair manual torches are designed to operate with a supporting power source and shop air supply (100 psi). The K-3 model is designed to operate with 5/32" (4 mm) to 3/8" (10 mm) diameter carbon electrode, the K-5 model is designed to operate with 5/16" (8 mm) to 5/8" (16 mm) diameter carbon electrode.

**SET-UP AND OPERATING INSTRUCTIONS
FOR MANUAL TORCH K-3 AND K-5 MODELS**

1. Select the size electrode to be used based on the recommended amperage range and carbon size in Table 1.
2. The electrode should be gripped in the holder to that a maximum of 6" (15 cm) extends from the holder to work.

3. Connect the electrode from the power supply and air supply to holder lead.
4. The D.C. power supply should be set to operate in reverse polarity and amperage depending on electrode size (See Table 1).
5. With the power and air supply turned on, press the torch valve button to turn on the air. Position the torch for a leading angle with the air jets in holder trailing the arc, strike arc and travel at a speed to maintain the depth of gouging required.

Electrode Size	1/4	5/16	3/8	1/2
Minimum Amps	200	250	350	600
Maximum Amps	400	450	600	1000

TABLE 1 - RECOMMENDED ELECTRODE SIZE AND AMPERAGE RANGE

GROOVE WIDTH (IN)	GROOVE DEPTH (IN)	ELECTRODE DIAMETER (IN)	AMPERES (DC)	VOLTS ELECTRODE POSITIVE	ELECTRODE FEED (IPM)	TRAVEL SPEED (IPM)
1/4	1/16	3/16	200	43	6.2	82
5/16	3/16	3/16	190	42	6.7	27.2
3/8	1/8	5/16	320	40	3	65.5
3/8	1/4	5/16	420	42	3.8	31.2
7/16	3/16	3/8	560	42	2.6	41
7/16	1/4	3/8	560	42	3	29.5

TABLE 2 -

WELDING DETAILS

Every field weld on a YORK Absorption unit should be a full penetration weld. Most welds can be butt welds. Butt welds are preferable because of their strength. **All weld root passes and hot passes must be made using Gas Tungsten-Arc Welding, commonly called TIG.**

The purpose of using TIG for the first two passes is primarily to provide a smooth crevice free surface on the inside of the pipe or shell. It is impossible to get such a surface using **Shielded Metal Arc Welding** (conventional stick). It must be remembered that any cracks or crevices will later be places for corrosion cells to form. A weld with porosity, holes, or crevices on the inside surface will quickly corrode and develop leaks. Every effort should be made to leave a smooth inner surface when making weld repairs.

When possible, finish weld any repair weld inside seam prior to closing up the unit. This is especially true when working on the generator or any area of strong solution concentration within the unit.



Do not weld a unit while that unit is under vacuum. A slight positive pressure should be present whenever welding.

Weld joints should be prepared as shown in Fig. 2. See the following Gas Tungsten Arc Welding Procedure (TIG) WPS No. 135-006-030 for the prescribed procedure.

Most of the steel shell material of a YORK Absorption unit is mild steel with a nominal thickness of 3/8" (10 mm). Almost all piping is Schedule 40 grade steel. If there is any doubt as to the exact metallurgy of an area of the unit, contact YORK Factory Service for the specific details.

GAS TUNGSTEN ARC WELDING PROCEDURE (TIG) WPS NO.135-006-030

Specifications

JOINTS	SEE FIG 2
PROCESS	GAS TUNGSTEN-ARC WELDING (GTAW) MANUAL
SPEC. NO	SFA 5.18
CLASS	ER70S-2
PREHEAT TEMP. RANGE	60° F MINIMUM
INTERPASS TEMPERATURE	350° F MAXIMUM
SHIELDING GAS	WELDING GRADE ARGON
% COMPOSITION	100
FLOW RATE	15 - 20 C.F.H.
WELD PASS THICKNESS	1/4" MAXIMUM
STRINGER OR WEAVE BEAD	EITHER
ORIFICE OR GAS CUP SIZE	NO. 4 - 8
OSCILLATION	UP TO 1/4"
ELECTRODE	2% THORIATED TUNGSTEN 1/16", 3/32", OR 1/8" DIA. CONE POINT
CURRENT	DC
POLARITY	STRAIGHT
AMPERAGE RANGE	75-250
ELECTRODE EXTENSION	3/16" TO 3/8"

PROCEDURE

Surfaces to be welded and an area of at least 1/2" (13 mm) from the weld joint preparation shall be smooth, clean and free from rust, scale and any other surface impurities. Cleaning shall be done by shot blasting, grinding, machining or wire brushing. Cleaning is required prior to welding and after each pass.

The shape of the tungsten is very important and should be shaped on a fine grinding wheel. The included angle of the point should be ground back about 22 to 23 degrees or to a distance equal to 2-1/2 times the electrode diameter. The tip should be blunted slightly less than 1/64" (1 mm).

Aligning of the weld joint is very critical and when

welding pipe, aligning should be done with some type of aligning fixture. Root opening and root face should be controlled to specified dimensions as illustrated in Fig. 2. Tacks shall be small and equally spaced to insure proper root opening during welding. A welder equipped with remote amperage control should be used to decay arc at end of weld. When remote amperage is not used, the arc should be moved to the side wall before ending weld. The end of tacks should be ground to a beveled end for starting and stopping points. The weld is started by holding the torch at a 90 to 75 degree angle with pipe or plate. The filler rod is positioned close to joint an arc in preparation for insertion. Filler rod is inserted in short strokes, at the same time moving the torch in the direction of the filler rod. To stop weld, hold torch over puddle for a few seconds until puddle cools.

When welding single welded pipe joints with 1/8" (3 mm) root opening, the weld should be stopped approximately 1/4" (6 mm) from a tack and the tack beveled by grinding or burring tool. Before starting to weld, the end of the weld or start of a tack should be beveled for easier starts. The travel speed and filler rod must be controlled to maintain a key-hole opening of 3/16" (5 mm) maximum. For better torch control when welding root pass, the nozzle or cup can be placed against the beveled surface and the electrode adjusted to proper distance from puddle.

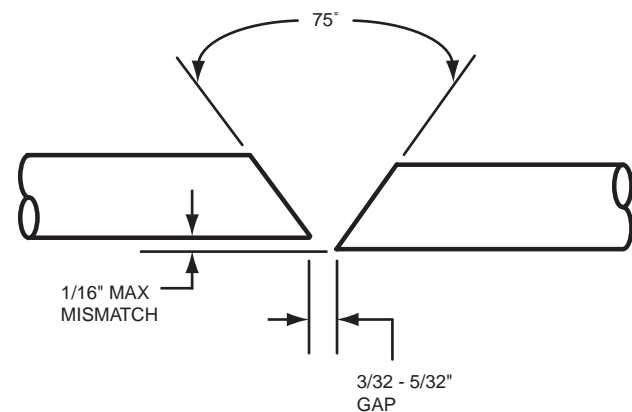

LD09444

FIG. 2 - WELD JOINT SET-UP

**SHIELDED METAL ARC-MANUAL
PROCEDURE (STICK) WPS NO.135-003-015**

Use for Cap (3rd Pass and Remainder of Passes)

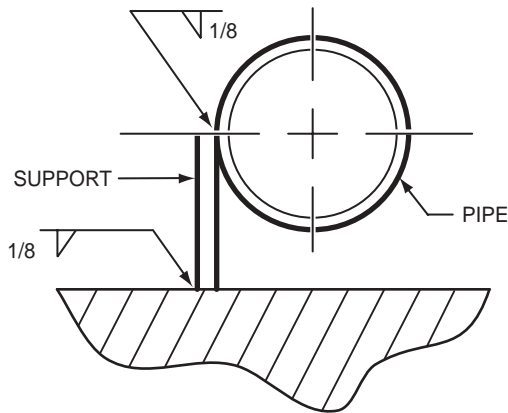

LD09447

FIG. 3 - WELDING PIPE SUPPORTS

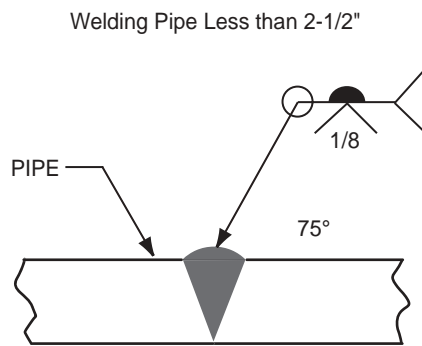

NOTE: Root pass TIG, when welding pipe larger than 2-1/2".

LD09448

FIG. 4 - WELDING PIPE

ELECTRODE	SFA5.1/E7018
CURRENT TYPE	Direct Current - Constant Current
POLARITY	Reverse Polarity - Electrode Positive
VOLTAGE	22 to 27 Volts
AMPERAGE	3/32 Flat - 90-115 amps; Out of Position-80-100 amps 1/8 Flat - 140-160 amps; Out of Position-110-130 amps 5/32 Flat - 185-220 amps; Out of Position-155-190 amps 3/16 Flat - 220-300 amps
MIN. PREHEAT TEMP.	60°
MAX. INTERPASS TEMP.	500° F
MAX. PASS THICKNESS	1/4"
OSCILLATION	Slight weaving is permitted but bead width shall not exceed six (6) times electrode diameter.
INITIAL CLEANING	The surface of parts to be welded shall be cleaned by machining, grinding, wire brushing, grit blasting, vapor degreasing, and/or solvent cleaning to remove scale, rust, oil, grease or other detrimental foreign material from the weld point and 1.0 inch of the base material adjacent to the weld preparation.
INTERPASS CLEANING	When weld material is to be deposited over a previously welded surface, all slag shall be removed by a slag pick, pneumatic slagger, wire brush, grinding, or other suitable means so as to prevent inclusions or impurities in the weld metal. Any cracks, porosity or undercutting which is evident shall be removed subsequent to any additional welding.

MELT-THROUGH SYMBOL

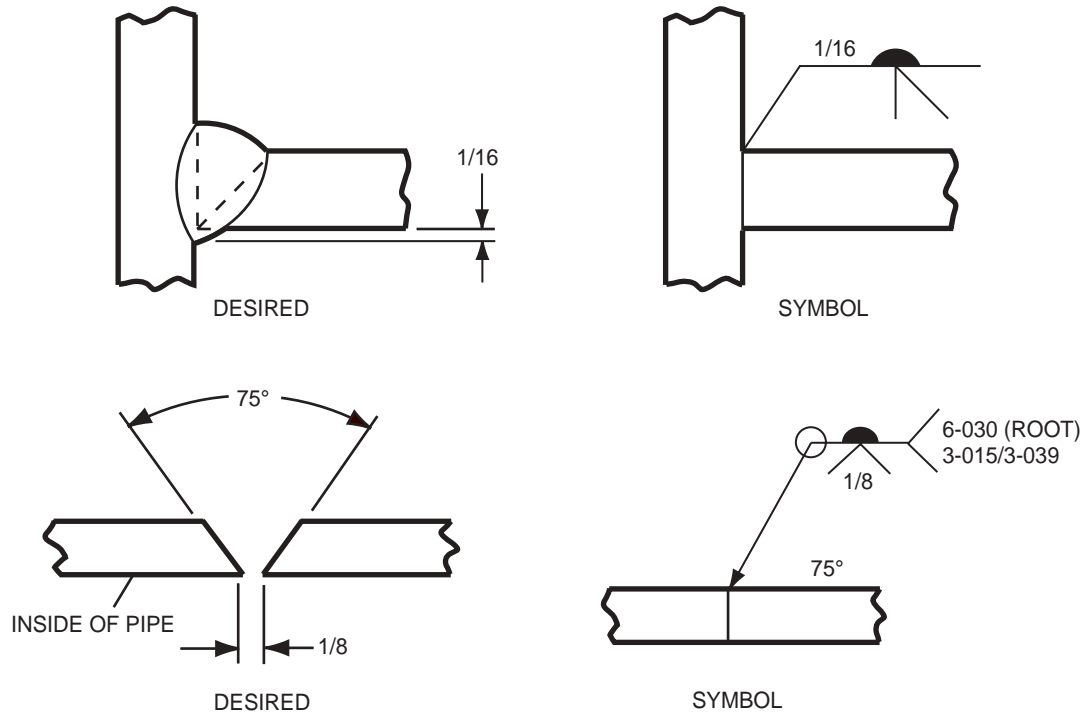

FIG. 6 - SYMBOLOGY

LD09446

NON-DESTRUCTIVE TESTING (NDT)

BASIC SYMBOLS

Basic nondestructive testing symbols shall be as follows:

TYPE OF TEST	SYMBOL
RADIOGRAPHIC	RT
MAGNETIC PARTICLE	MT
PENETRANT	PT

GENERAL PROVISIONS

Location of Testing Symbol

When nondestructive testing symbols have no arrow or other side significance, the testing symbols shall be centered on the reference line as follows:

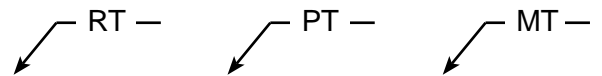

When nondestructive tests are to be made on the arrow side, other side or both sides of the part, the testing symbols shall be indicated as follows:

