



**SINGLE-STAGE ISOFLOW™  
ABSORPTION LIQUID CHILLERS**

OPERATING AND MAINTENANCE INSTRUCTIONS

New Release

Form 155.16-OM1 (1200)

**MODELS YIA 1A1 THROUGH YIA 14F3**

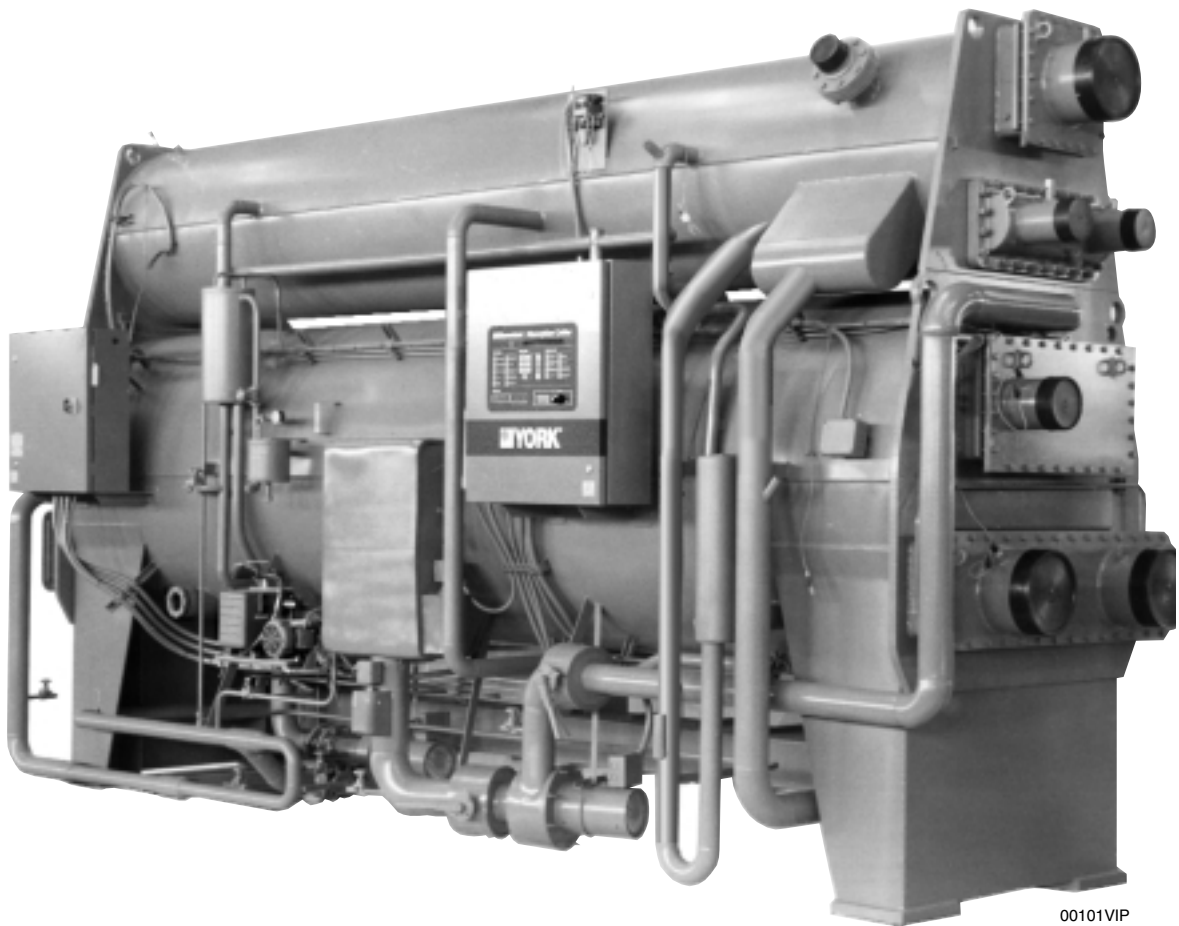

00101VIP

# TABLE OF CONTENTS

<b>Section 1</b>	<b>INTRODUCTION</b> .....	6
	GENERAL.....	6
	NOMENCLATURE.....	6
<b>Section 2</b>	<b>ABSORPTION SYSTEM OPERATION</b> .....	7
	GENERAL INFORMATION .....	7
	Evaporator.....	7
	Absorber .....	7
	Generator .....	7
	Condenser .....	7
	DESCRIPTION OF MAJOR COMPONENTS AND SUB-SYSTEMS .....	9
	General Condenser Shell Assembly.....	9
	Evaporator-Absorber Shell Assembly .....	9
	Solution Pump .....	9
	Refrigerant Pump .....	9
	Heat Exchanger .....	9
	Purge System .....	9
	Controls and Wiring .....	9
	CONTROL DESCRIPTIONS.....	10
	Components in the Control Center .....	10
	Components of Power Panel .....	10
	Components External to the Control Center .....	12
	CONTROL SEQUENCE .....	14
	SYSTEM OPERATION .....	16
	General .....	16
	CAPACITY CONTROL .....	19
	General .....	19
	Maximum Load Limits at Reduced Condensing Water Temperatures.....	19
	Solution and Refrigerant Interchange During Operation .....	19
	Anti-Freeze Line.....	22
	Chilled Water Control Stability .....	22
	Stabilizer Refrigerant Solenoid (2SOL).....	22
	Capacity Control Valve Override.....	22
	Automatic Decrystallization Control .....	22
	DISCUSSION OF SUB-SYSTEM OPERATION .....	22
	Automatic Decrystallization Feature .....	22
	Basic Automatic Decrystallization Piping Circuit – Model YIA, All Sizes ..	23
	ADC Flush Line .....	23
	Combination of Basic ADC Piping Circuit and ADC Control Feature .....	23
	2SOL – Refrigerant Valve Blowdown.....	24
<b>Section 3</b>	<b>PURGE SYSTEM OPERATION</b> .....	26
	GENERAL.....	26
	FUNCTION .....	26
	SYSTEM DETAILS .....	28

<b>Section 4</b>	<b>PURGE PUMP OPERATION</b> .....	29
	GENERAL .....	29
	Cleanliness .....	29
	Types of Lubricants .....	29
	PURGE PUMP PIPING AND OPERATING VALVES .....	29
	The Principle of Gas Ballast .....	29
	OIL LEVEL DETERMINATION .....	29
<b>Section 5</b>	<b>PURGE PUMP MAINTENANCE</b> .....	30
	VACUUM PROBLEMS .....	30
	Pressure Determinations .....	30
	Oil Contamination .....	30
	OIL CHANGES AND OIL LEVELS .....	30
	Draining The Pump .....	30
	Flushing The Pump .....	30
	Refilling The Pump .....	31
	SHAFT SEAL REPLACEMENT .....	31
	REPAIRING OIL LEAKS .....	31
	Location, Cause and Effect .....	31
	Repairing Technique .....	31
	DRIVE PROBLEMS .....	32
<b>Section 6</b>	<b>BUFFALO PUMPS</b> .....	34
	INTRODUCTION .....	34
	TROUBLESHOOTING .....	34
	Pump Tripping On Overloads .....	34
	Pump Tripping On Thermal Protection .....	34
	Unusual Noise/Vibration .....	34
	Pump Overhaul .....	34
<b>Section 7</b>	<b>STEAM AND WATER QUALITY CONTROL</b> .....	36
	GENERAL .....	36
	STEAM/CONDENSATE OR HOT WATER QUALITY .....	36
	TUBE CLEANING .....	37
<b>Section 8</b>	<b>UNIT OPERATING PROCEDURES</b> .....	38
	GENERAL .....	38
	START-UP (NORMAL) .....	38
	SHUTDOWN (NORMAL) .....	39
	Manual Shutdown .....	39
	OPERATING DATA .....	39
	General .....	39
	Performance Data and Calculations .....	40

<b>Section 9</b>	<b>PTX CHART</b> .....	42
	READING THE PTX CHART .....	42
	CRYSTALLIZATION .....	42
	PRESSURE DROP CURVES .....	45
	REFRIGERANT CONCENTRATION .....	45
<b>Section 10</b>	<b>PREVENTATIVE MAINTENANCE</b> .....	57
	CLEANING AND MAINTAINING THE TUBES WITHIN THE SHELLS .....	57
	Tubes .....	57
	BRUSH CLEANING OF TUBES .....	57
	TROUBLESHOOTING TABLE .....	58
	PREVENTATIVE MAINTENANCE SCHEDULE .....	59
 <b>APPENDIX</b>		
	Glossary Of Terms .....	61

## LIST OF ILLUSTRATIONS

<b>Fig. 1</b>	– Basic Cycle Diagram .....	8
<b>Fig. 2</b>	– Typical Power Panel.....	11
<b>Fig. 3</b>	– Model YIA Absorption Unit, Front View .....	13
<b>Fig. 4</b>	– System Control Components Location .....	15
<b>Fig. 5</b>	– Evaporator .....	16
<b>Fig. 6</b>	– Absorber.....	16
<b>Fig. 7</b>	– Solution Pump .....	16
<b>Fig. 8</b>	– Generator .....	16
<b>Fig. 9</b>	– Condenser.....	17
<b>Fig. 10</b>	– Cycle Diagram (Hot Water Units and Steam Units) .....	18
<b>Fig. 11</b>	– IsoFlow Absorption System Solution Concentration Average in System Solution Circuit .....	19
<b>Fig. 12</b>	– Solution and Refrigerant Level Variation With Load .....	20
<b>Fig. 13</b>	– Automatic Decrystallization Feature (Hot Water Units & Steam Units with ADC Control) .....	25
<b>Fig. 14</b>	– Bubble Testing for Leaks.....	26
<b>Fig. 15</b>	– IsoFlow™ Purge System .....	27
<b>Fig. 16</b>	– Purge Drum Details .....	28
<b>Fig. 17</b>	– The Complete Purge System .....	28
<b>Fig. 18</b>	– Purge Pump Piping & Valves - Normal Operation .....	29
<b>Fig. 19</b>	– Model 1402 Vacuum Pump for YORK .....	33
<b>Fig. 20</b>	– Flow of Refrigerant Water or Lithium Bromide through Pump .....	35
<b>Fig. 21</b>	– Acceptable Unit Internal Pressures .....	38
<b>Fig. 22</b>	– Operating Data Sheet .....	41
<b>Fig. 23</b>	– PTX Chart .....	43
<b>Fig. 24</b>	– Pressure Drop Curves .....	46
<b>Fig. 25</b>	– Pressure Equivalents .....	65
<b>Fig. 26</b>	– Vacuum Units of Measurement .....	65
<b>Fig. 27</b>	– Complete Cycle Diagram.....	67

# IMPORTANT!

## READ BEFORE PROCEEDING!

### GENERAL SAFETY GUIDELINES

This equipment is a relatively complicated apparatus. During installation, operation, maintenance or service, individuals may be exposed to certain components or conditions including, but not limited to: refrigerants, oils, materials under pressure, rotating components, and both high and low voltage. Each of these items has the potential, if misused or handled improperly, to cause bodily injury or death. It is the obligation and responsibility of operating/service personnel to identify and recognize these inherent hazards, protect themselves, and proceed safely in completing their tasks. Failure to comply with any of these requirements could result in serious damage to the equipment and the property in which it is situated, as well as severe

personal injury or death to themselves and people at the site.

This document is intended for use by owner-authorized operating/service personnel. It is expected that this individual possesses independent training that will enable them to perform their assigned tasks properly and safely. It is essential that, prior to performing any task on this equipment, this individual shall have read and understood this document and any referenced materials. This individual shall also be familiar with and comply with all applicable governmental standards and regulations pertaining to the task in question.

### SAFETY SYMBOLS

The following symbols are used in this document to alert the reader to areas of potential hazard:



***DANGER*** indicates an imminently hazardous situation which, if not avoided, will result in death or serious injury.



***CAUTION*** identifies a hazard which could lead to damage to the machine, damage to other equipment and/or environmental pollution. Usually an instruction will be given, together with a brief explanation.



***WARNING*** indicates a potentially hazardous situation which, if not avoided, could result in death or serious injury.

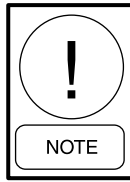

***NOTE*** is used to highlight additional information which may be helpful to you.

### CHANGEABILITY OF THIS DOCUMENT

In complying with YORK's policy for continuous product improvement, the information contained in this document is subject to change without notice. While YORK makes no commitment to update or provide current information automatically to the manual owner, that information, if applicable, can be obtained by contacting the nearest YORK Applied Systems Service office.

It is the responsibility of operating/service personnel as to the applicability of these documents to the equipment in question. If there is any question in the mind of operating/service personnel as to the applicability of these documents, then, prior to working on the equipment, they should verify with the owner whether the equipment has been modified and if current literature is available.

# SECTION 1 – INTRODUCTION

## GENERAL

This manual contains instructions and information required by the operator for proper operation and preventative maintenance of the YORK IsoFlow Absorption Liquid Chillers.

Included in this instruction are discussions of the basic principles of operation of Lithium Bromide Absorption Systems and descriptions of the functional operation of major components and sub-systems. Instructions related to the controls and normal operating sequence of the various modifications of the IsoFlow units can be found in Form 155.16-O3 "Operators Manual – Control Panel" and Form 155.16-N3, "IsoFlow Installation Manual".

Procedures and checks to be conducted by the operator are described extensively for all areas of operation. These involve the Pre-Start modes of units, normal operation of units and operational functions related to general performance of the system. Information and guides are given pertaining to care and general maintenance of the unit.

## NOMENCLATURE

A system of nomenclature used for identification purposes of Model YIA Absorption Chillers is described as follows.

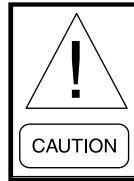

*It is imperative that the operator know the designation of any given unit intended to be operated in accordance with this instruction; this is necessary to ensure that the appropriate sections of this manual are applied. The unit designation can be determined from the unit data plate on the side of the control panel. The unit serial number is also shown.*

---

## NOMENCLATURE

The model number denotes the following characteristics of the unit:

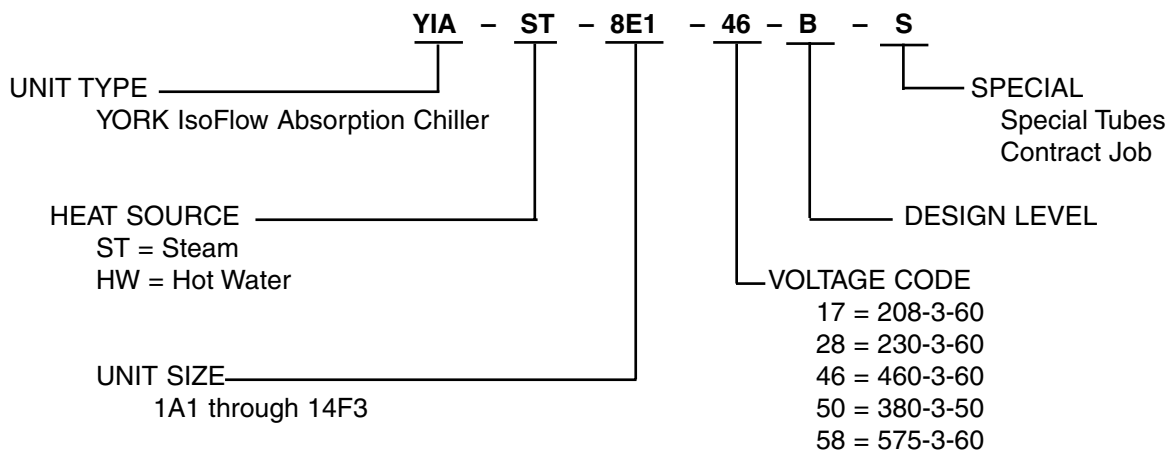

## SECTION 2 – ABSORPTION SYSTEM OPERATION

### GENERAL INFORMATION

The principle of refrigeration is the exchange of heat and, in absorption liquid chilling, there are four basic heat exchange surfaces: the evaporator, the absorber, the generator and the condenser. Refer to Figure 1.

In absorption chilling, the refrigerant is water but, like any refrigeration system, absorption chilling uses evaporation and condensation to remove heat. To maintain effective evaporation and condensation, absorption chilling employs two shells which operate at different, controlled vacuums.

The lower shell (Evaporator and Absorber) has an internal absolute pressure of about one one-hundredth that of the outside atmosphere - or six millimeters of mercury, a relatively high vacuum. The vacuum allows water (the refrigerant) to boil at a temperature below that of the liquid being chilled. Thus, chilled liquid entering the evaporator can be cooled for air conditioning or process cooling applications.

#### Evaporator

Refrigerant enters the top of the lower shell and is sprayed over the evaporator tube bundle. Heat from the liquid being chilled evaporates the refrigerant.

#### Absorber

The refrigerant vapor then migrates to the bottom half of the lower shell. Here, the vapor is absorbed by a lithium bromide solution. Lithium bromide solution is basically nothing more than salt water. However, lithium bromide is a salt with an especially strong attraction for water. The mixture of lithium bromide and the re-

frigerant vapor - called the “dilute solution” - now collects in the bottom of the lower shell.

#### Generator

The dilute solution is then pumped through the heat exchanger, where it is preheated by hot concentrated solution from the generator. The heat exchanger improves the efficiency of the cycle by reducing the amount of steam or hot water required to heat the dilute solution in the generator.

The dilute solution then continues to the upper shell containing the Generator and Condenser, where the absolute pressure is approximately one-tenth that of the outside atmosphere, or seventy millimeters of mercury. The dilute solution flows over the generator tubes and is heated by steam or hot water passing through the interior of the tubes. The amount of heat input from the steam or hot water is controlled by a motorized valve and is in response to the required cooling load. The hot generator tubes boil the dilute solution, releasing refrigerant vapor.

#### Condenser

The refrigerant vapor rises to the condenser and is condensed by the cooler tower water running through the condenser tubes. The liquid refrigerant flows back to the lower shell, and is once again sprayed over the evaporator. The refrigerant cycle has been completed. Now the concentrated lithium bromide solution flows from the generator back to the absorber in the lower shell, ready to absorb more refrigerant. Its cycle has also been completed.

# MODEL Y1A STANDARD STEAM CYCLE DIAGRAM

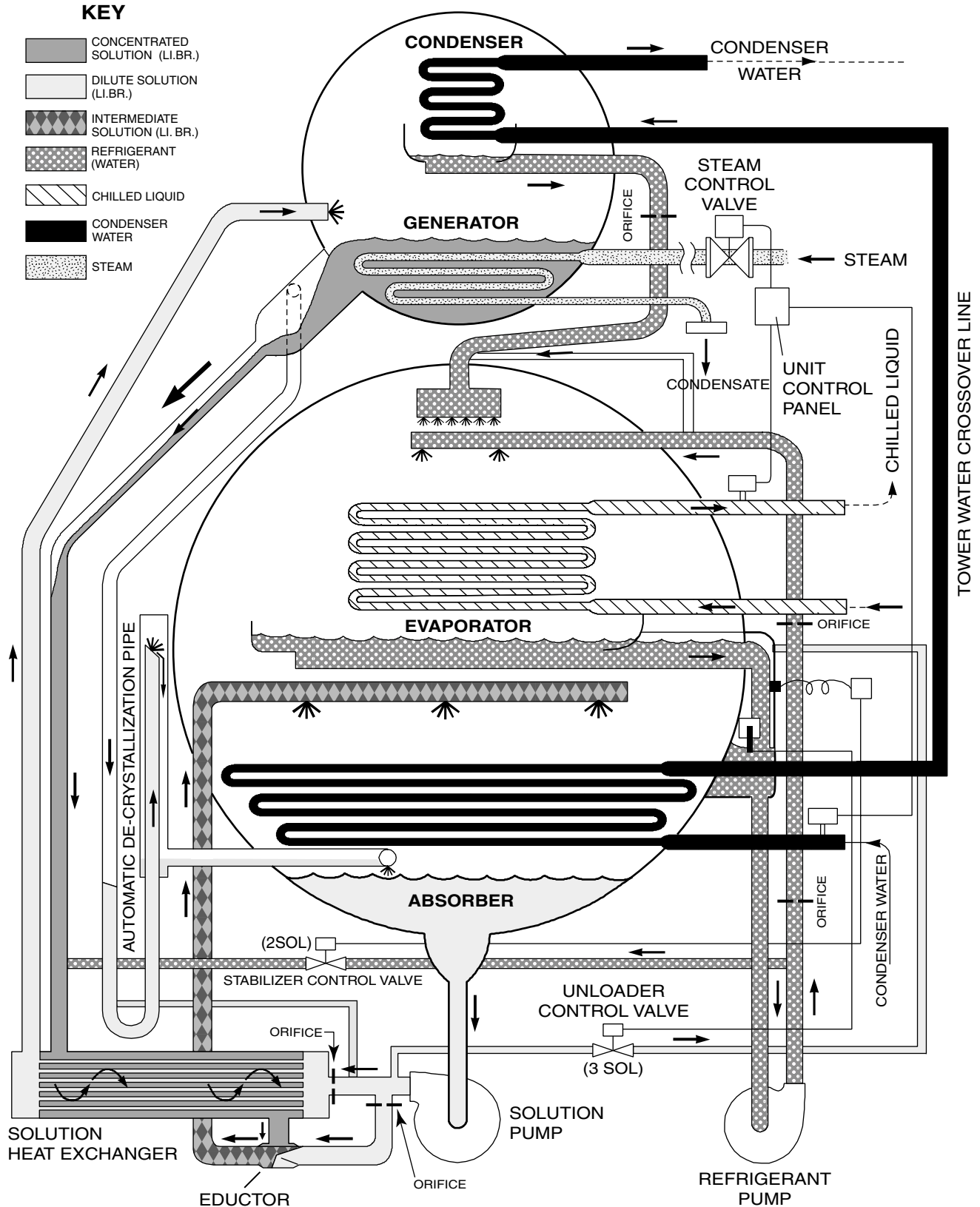

Note: Some orifices may differ between various models.

LD04763

FIG. 1 – BASIC CYCLE DIAGRAM

## DESCRIPTION OF MAJOR COMPONENTS AND SUB-SYSTEMS

The YORK IsoFlow Absorption Chillers consist of the following major components and sub-systems:

### Generator-Condenser Shell Assembly

This is the upper of two cylindrical shells, and it contains two tube bundles - the generator and the condenser. The generator is a single pass flooded tube bundle when operated with steam, and may be a one or two-pass flooded tube bundle when operated with hot water.

The steam or hot water flowing through the tube bundle boils the water vapor from the solution that surrounds the outside surface of the generator tubes. The condenser section of this shell assembly consists of a single-pass tube bundle through which cooling water is circulated (condensing the water vapor boiled off in the generator) and a condenser pan to collect the water.

### Evaporator-Absorber Shell Assembly

This is the lower shell assembly and it also contains two sections - the evaporator and the absorber.

The evaporator consists of a single or multi-pass tube bundle, a refrigerant pan, and a refrigerant spray header assembly. The liquid to be chilled (usually water) flows through the tubes to be cooled by vaporization of the liquid refrigerant (water condensed in the condenser). The liquid refrigerant is pumped through the sprays and flows down over the outside surface of the evaporator tubes.

The absorber consists of a single or multi-pass tube bundle, the absorber spray header assembly, and the lower part of the shell, which serves as a solution storage pan. Tower water is circulated through the absorber tubes to cool the lithium bromide solution being sprayed over the outside of the tubes. This aids the absorption process.

### Solution Pump

The unit has one solution pump mounted under the lower shell. This pump transfers dilute solution to the generator from the absorber and, with the aid of an eductor, pumps mixed (intermediate) solution to the absorber sprays.

### Refrigerant Pump

All units have one refrigerant pump mounted beneath the lower shell to recirculate refrigerant to the evaporator sprays and over the evaporator tubes.

### Heat Exchanger

The heat exchanger is mounted under the lower shell to improve system efficiency by transferring heat from the warm concentrated solution (low water content) to the relatively cool dilute solution (high water content) on its way to the generator. This assists both the generator in heating and the absorber in cooling the dilute and concentrated solutions respectively.

### Purge System

YORK absorption systems are designed and manufactured for extreme leak tightness to ensure against infiltration of non-condensables into the high-vacuum system. Leakage of air into the system will deteriorate the refrigeration capability of the unit as the absolute pressure in the unit rises, and corrosion problems could develop.

The purge system provides a means for ridding the unit of any such accumulation of non-condensables. The system consists of a purge header arrangement in the bottom absorber section, a purge drum, a purge pump, and associated connection piping with hand valves. During unit operation, condenser water is circulated through a coil in the purge drum while solution is sprayed over the coil, inducing and absorbing water vapor and making it possible to pump a higher concentration of non-condensables (if they exist) from the system by means of the purge pump furnished with the system.

### Controls and Wiring

An electronic control system is provided with each absorption unit to permit automatic or manual control of the system. Provisions are made for the following:

1. Automatic capacity control involving electronic controls for steam or hot water valves.
2. Safety controls involving flow switches, float switches, low refrigerant temperature cut-out, motor overloads and protective thermostats.
3. Special control features to provide for steam economy and for prevention of crystallization.

## CONTROL DESCRIPTIONS

4. Functional controls which permit operation over a wide range of condenser water temperatures.

### COMPONENTS IN THE CONTROL CENTER

See IsoFlow Panel Instruction, Form 155.16-O3.

### COMPONENTS IN POWER PANEL (See Figure 2)

#### 1SW – Service Disconnect Switch

This is a non-fused, service disconnect switch. The incoming power lines from the customer-supplied fused disconnect switch or circuit breaker should be connected to terminals L1, L2, and L3 of this switch.

#### 1T – Transformer

This is a step-down transformer that reduces the unit's incoming power (primary) down to the required control voltage of 120/115-1-50/60 (secondary).

#### 1FU, 2FU, 3FU – Control Fuses

Used on all 60 Hz standard (NEMA 1) units. 1FU and 2FU are on the primary side of the 1T transformer. The amperage rating of these fuses depends on the unit's voltage. The 3FU fuse is always a 10-amp fuse and is on one leg of the secondary coil of the 1T transformer. It is used for the control panel voltage.

#### 1CB – Circuit Breaker

Takes the place of 1FU and 2FU on 60 Hz NEMA 4

units and 50 HZ, 380 volts units.

#### 2CB – Circuit Breaker

Takes the place of 3FU on 60 Hz NEMA 4 units and 50 Hz, 380 volts units.

#### 1M – Starter/Contactor for Solution Pump

Used on all units.

#### 2M – Starter/Contactor for Refrigerant Pump

Used on all units.

#### 3M – Starter/Contactor for Purge Pump

Used on all units.

#### 1OL thru 3OL – Overloads

Each starter/contacter is accompanied by a heater element overload with resetting capability. The designation number of the overload matches the designation number of the starter/contacter.

#### MTH1 and MTH2 – Motor Thermostats

Used on all units with Buffalo Pumps. These Klixon type thermostats are imbedded in the motor windings and will open when the motor internal temperature reaches 300°F (150°C) to 392°F (200°C), depending on pump type. The thermostats will automatically reset when the motor windings cool down 27°F (15°C) from the trip point.

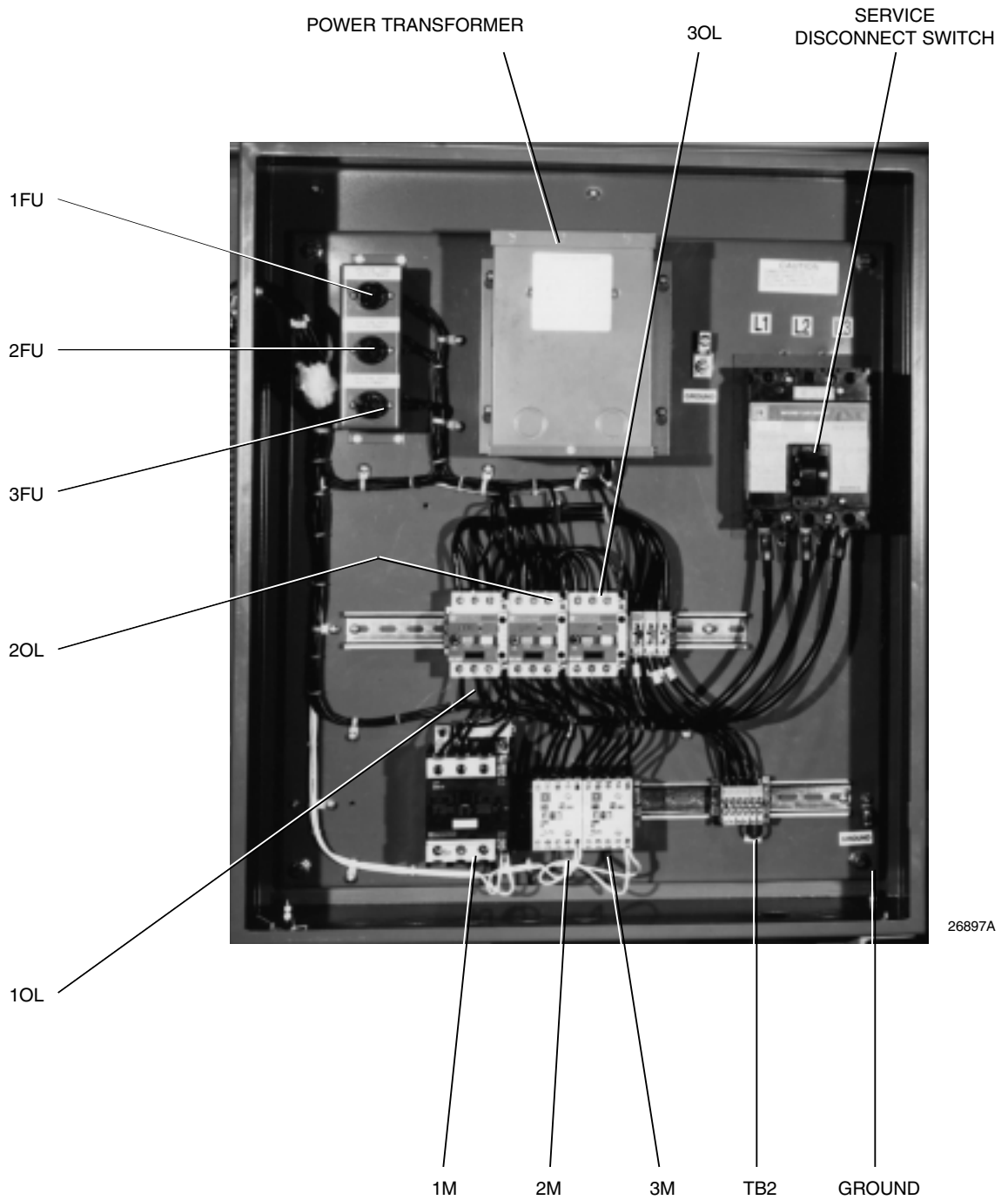

FIG. 2 – TYPICAL POWER PANEL (60 HZ, NEMA 1 STANDARD UNIT POWER PANEL SHOWN)

## CONTROL COMPONENTS EXTERNAL TO THE CONTROL CENTER (See Figure 3)

### Hermetic Motor Thermostats (Not Shown) –

The Buffalo Solution and Refrigerant pump motors are cooled by the circulating fluid. In the case of inadequate cooling, each motor has an internal motor protector of the Klixon type imbedded in the motor windings to protect the motor from damage if overheating occurs.

### 1F – Refrigerant Level Float Switch

This float switch is installed in a separate chamber on the side of the refrigerant outlet box, hanging off the evaporator. It senses when the refrigerant level is low enough that the refrigerant pump could cavitate and cease to sustain the flow of refrigerant to the evaporator sprays. Should this occur, as it will at low loads with low tower water temperature to the absorber, 3SOL will be energized to permit solution to come into the refrigerant circuit to satisfy the pump needs and sustain unit operation.

### 3F – Refrigerant Pump Cutout Float Switch

This float switch is installed in a separate chamber located on the refrigerant pump suction line just upstream of the refrigerant pump inlet. It is used in conjunction with 1F to detect insufficient refrigerant to the Buffalo refrigerant pump. When the refrigerant level has decreased below the level that allows refrigerant pump cutout float 3F switch to open and it remains open continuously for the duration of the programmed preset time, the refrigerant pump will be shut down.

### FLS – Flow Switch (Chilled Water)(Not Shown) –

The purpose of this switch is to stop the unit when insufficient chilled water is flowing to provide satisfactory operation. The switch is customer-installed in either the chilled inlet or outlet line and wired to the control panel. For instructions on how to install this switch, refer to Form 155.16-N3, “IsoFlow Installation Manual”.

### 1SOL – Motor Coolant Solenoid Valve

Not used on units with Buffalo Pumps.

### 2SOL – Stabilizer Refrigerant Solenoid Valve

Basically, the 2SOL works in conjunction with the Automatic Decrystallization mode of the unit. **When RT2 senses an increase of temperature to 160°F (71.1°C) in the ADC line, the stabilizer refrigerant solenoid valve is energized for 2 minutes.** This transfers refrigerant to the generator's drain line and thus to the shell side of the heat exchanger to dilute the solution.

A second function of this solenoid valve is to manually energize it from the micro control panel to act as a refrigerant "blow down". For further details of this valve and its operations, refer to Form 155.16-O3, “Operators Manual – Control Panel”.

### 3SOL – Refrigerant Level Solenoid Valve (Unloader Valve)

The function of this valve is **two-fold**: 1. It transfers diluted solution from the discharge of the solution pump to the evaporator refrigerant outlet box. When float 1F opens, 3SOL energizes to allow solution to flow, thus keeping the refrigerant pump from cavitating. This might occur at light loads and with low temperature tower water to the absorber shell. 2. When the solution is allowed to mix with the refrigerant, the contamination decreases the refrigeration effect through the evaporator, thus allowing the unit to stay online longer during periods of low loads.

### 4SOL – Automatic Shut-Off Valve (Not Shown)

This valve is a customer supplied and installed valve. It is located upstream of the YORK-supplied control valve. It ensures 100% shut-off during a cycling/safety shutdown or a power failure. It works in conjunction with the 6SOL steam condensate drain solenoid valve. For details on this valve, refer to Form 155.16-N3, “IsoFlow Installation Manual”.

### 5SOL – Purge Solenoid Valve

This valve is no longer used with units that have Welsh vacuum pumps installed from the factory.

### 6SOL – Steam Condensate Drain Solenoid Valve (Steam units only) (Not Shown)

This valve is located on the condensate outlet box of the generator shell, opposite the steam inlet. It is a

FIG. 3 - MODEL Y1A ABSORPTION UNIT, FRONT VIEW

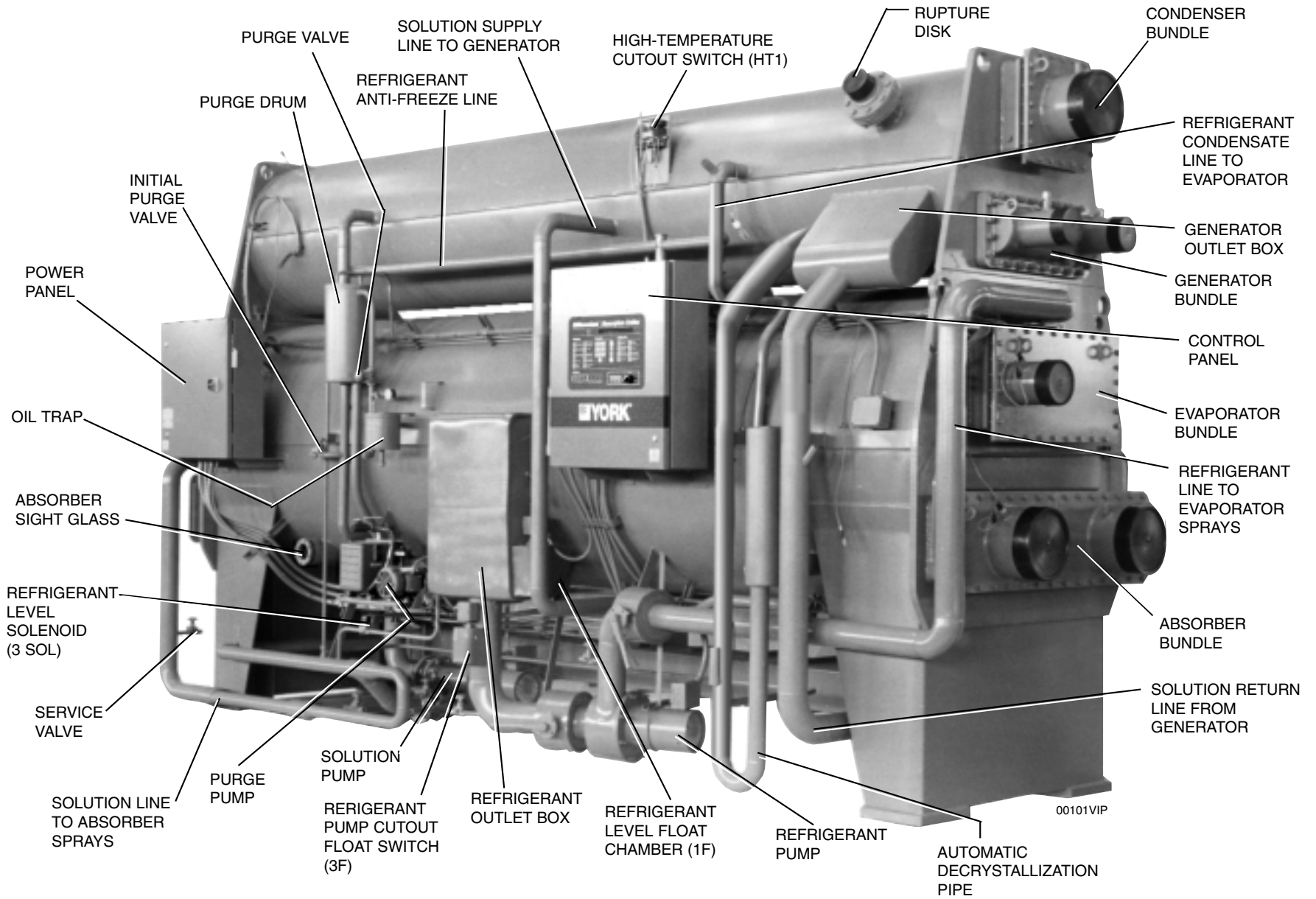

normally closed (NC) valve and is energized at all times during unit operation. The function of this valve is to stop all steam flow through the generator when the unit is off or during a power failure. This valve is shipped loose with the unit for field installation. See Form 155.16-N3, "IsoFlow Installation Manual" for details on installing this valve.

#### **HP1 – High Pressure Cutout Switch (Not Shown)**

This digital safety switch is located directly off the top of the condenser shell, control panel side, and is hardwired directly into the control panel. It is factory preset to trip the unit when the unit internal pressure reaches 710 mm Hg Abs. It will automatically reset itself when the units pressure reduces to 40 mm Hg Abs.

#### **HT1 – High Temperature Cutout Switch**

This digital safety switch is located on the control panel side of the generator shell with an accompanying thermistor inserted into an adjacent thermowell. It is hardwired directly into the control panel and factory set to trip the unit when the generator shell skin temperature reaches 330°F (165.6°C). It has a manual reset push button and an amber light on the control to indicate it is functioning.

#### **LRT – Low Refrigerant Temperature Cutout Switch**

This digital safety switch is located on the opposite side of the refrigerant outlet box from the 1F float

switch. It has an attached thermistor, which is inserted into a thermowell that is located on the refrigerant line leading out of the bottom of the refrigerant outlet box. The switch protects the unit from freezing refrigerant. It is factory preset to trip at 39.1°F (3.9°C). It will automatically reset when the temperature difference increases 5°F (2.78°C).

#### **Control Valve (Not Shown)**

This valve is used to control the amount of heat energy (steam or hot water) that enters the generator section of the unit.

It receives a control signal (115VAC) from the Control Panel to open or close to control the Leaving Chilled Water Temperature (LCWT) to the Leaving Chilled Water Temperature Setpoint. If the heat source is steam, the maximum inlet temperature is 337°F (169°C). If the heat source is hot water, the maximum inlet temperature is 266°F (130°C).

#### **CONTROL SEQUENCE**

For Control Sequence, see Form 155.16-O3, "Operators Manual – Control Panel".



# SYSTEM OPERATION

## GENERAL

### (Based On Standard Steam Units – Model YIA)

The cycle diagram for Model YIA steam / hot water operated systems is shown in Figure 10. The following discussion will describe the absorption system operation generally, in reference to this particular configuration.

Liquid, usually water, for air conditioning duty or process duty is chilled as it passes through the evaporator tubes by giving up heat to refrigerant flowing over the outside of the tubes. This heat causes refrigerant to evaporate since it is at a pressure with a corresponding boiling temperature lower than the leaving chilled water temperature. For example, water is chilled from 54°F to 44°F with the evaporator at 6.3 mm. Hg. absolute pressure corresponding to 40°F boiling point. (Refer to Figure 5.)

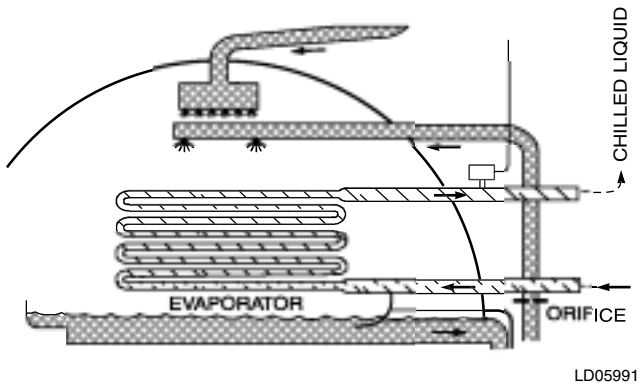

FIG. 5 – EVAPORATOR

Refrigerant vapor in the evaporator is attracted and absorbed by intermediate lithium bromide solution flowing over the outside of the absorber tubes thus diluting the solution. Heat generated in the process (heat of absorption) is removed by condensing water from a cooling tower or other source flowing through the absorber tubes. (See Figure 6.)

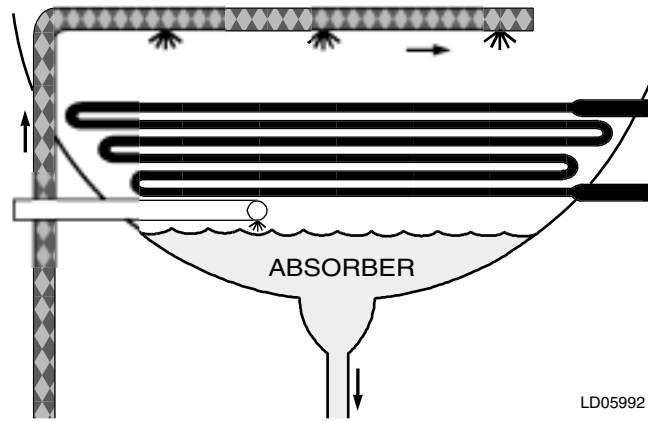

FIG. 6 – ABSORBER

Relatively dilute solution from the bottom of the absorber is pumped by the solution pump, through the heat exchanger, where it is regeneratively heated by hot concentrated solution draining from the generator. The solution then travels up to the generator. (See Figure 7.)

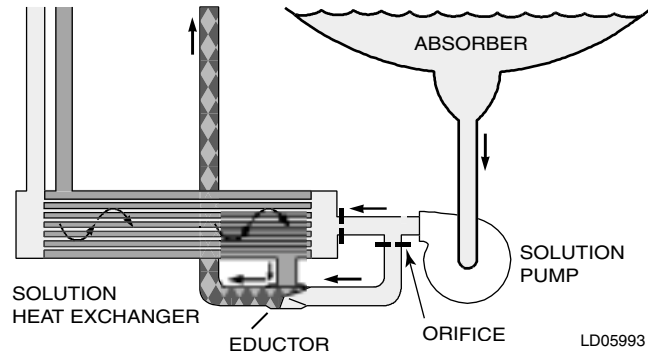

FIG. 7 – SOLUTION PUMP

Generator tubes are submerged in lithium bromide solution which enters the generator in a dilute condition at one end and leaves concentrated at the opposite end. A portion of the refrigerant is vaporized by steam or hot water flowing through the generator tubes, thus concentrating the solution. (See Figure 8.)

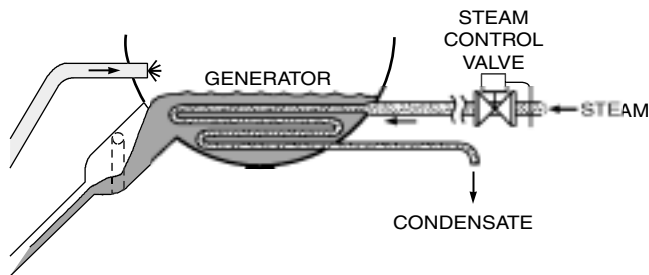
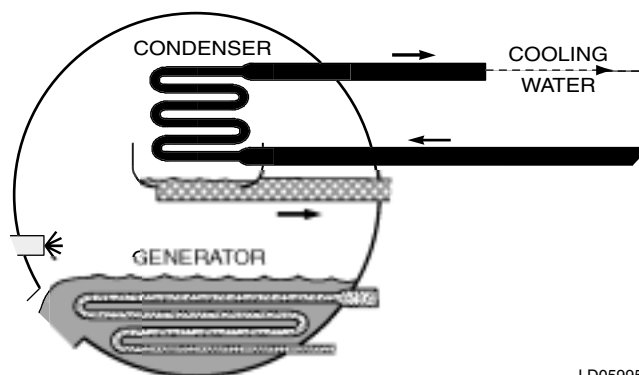

FIG. 8 – GENERATOR

Concentrated solution flows by gravity and pressure differential through the heat exchanger, where it is cooled regeneratively by cooler dilute solution. The heat exchanger has thus improved the efficiency of the system by reducing the amount of steam or hot water required to heat the dilute solution in the generator and the amount of concentrated solution cooling required in the absorber.

An intermediate solution consisting of a mixture of cooled concentrated solution together with dilute solution from the bottom of the absorber is recirculated over the absorber tubes by the solution pump, with the aid of the eductor, to complete the solution cycle.

Refrigerant vapor released from the dilute solution in the generator is condensed on the condenser tubes by giving up its heat of condensation to condensing water passing through the tubes. This condensing water is the same water that has been previously used to cool the absorber. (See Figure 9.)



LD05995

**FIG. 9 – CONDENSER**

Condensed refrigerant flows by gravity and pressure differential through an orifice or expansion device to the evaporator. This refrigerant, plus that recirculated by the refrigerant pump, is distributed over the evaporator tubes to complete the refrigerant cycle.

Capacity of the unit is automatically controlled from the temperature of the chilled water leaving the evaporator. The steam or hot water control valve meters the steam or hot water flow to the generator. Refer to Figure 10 on page 18 for complete cycle diagram.

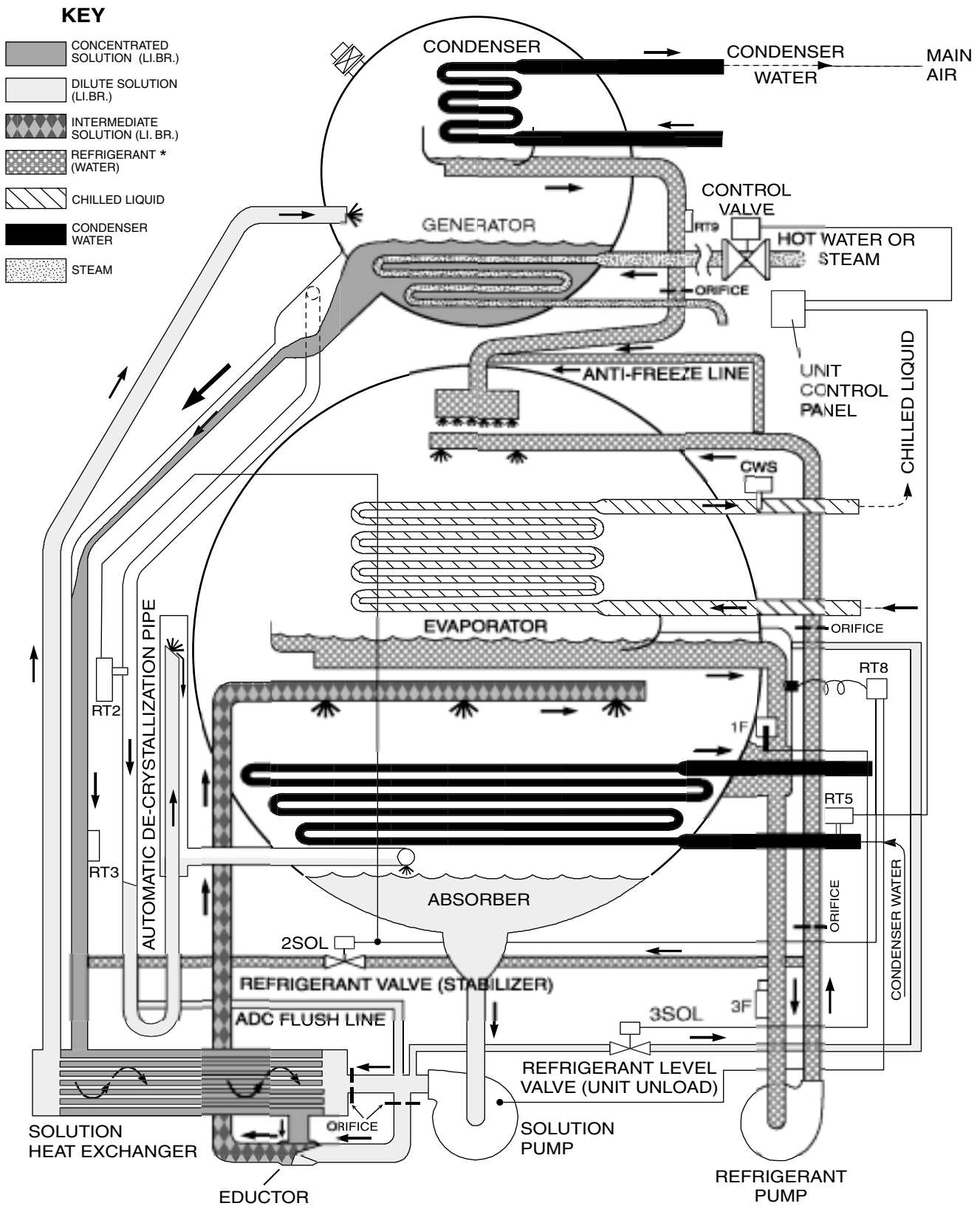

\* Mild Solution at Low Loads & Low Condensing Water Temperatures except where shaded.

**Note:** Orifices may differ between various models.

LD04764

**FIG. 10 – CYCLE DIAGRAM (HOT WATER UNITS & STEAM UNITS)**

## CAPACITY CONTROL

### General

The YIA control panel operates to control the capacity of the system by the throttling action of the steam valve.

### Maximum Load Limits at Reduced Condensing Water Temperatures

All York IsoFlow absorption units which incorporate the Millennium Control Center have a programmable entering condenser water temperature from 75°F to 125°F (23.8°C to 51.6°C). The programmed value is bypassed for the first 30 minutes at unit start-up. For more details on how to program and operate the Millennium Control Center see Form 155.16-O3, "Operators Manual – Control Panel".

For all model units, the minimum entering condensing water temperature for full load operation is 74°F (23.3°C). The chart below is an approximation of percent of full load tonnage achievable for different condensing water inlet temperatures:

CONDENSING WATER INLET TEMPERATURE	% NOMINAL UNIT TONS
45°F (7.2°C)	43
55°F (12.8°C)	58
65°F (18.3°C)	78
74°F (23.3°C)	100

Because of load variations, outside wet bulb temperatures, and cooling tower size, the refrigeration load may tend to exceed the maximum allowable. In this case, the tower fan thermostat(s) must be set to adjust tower capacity as required. Fan cycling or speed modification is thus used to produce any desired minimum cooling water temperature. For maximum economy and stability of operation, the tower fan thermostat(s) should be set to give the lowest cooling water temperature possible without the temperature cycling below these limits.

As the condensing tower water temperature reduces, hence a reduction in the water temperature to the absorber/condenser bundles, increased activity in the generator occurs. This causes carry-over of solution from the generator bundle to the condenser bundle to an undesirable degree.

On the chart below, these limits are indicated by lines B and C for their corresponding ranges. The chart assumes that the unit is free of scale and non-condensables.

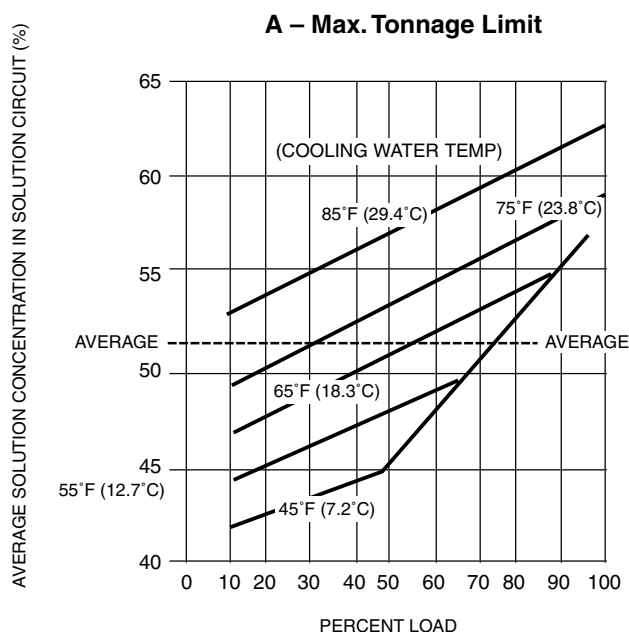

**FIG. 11 – ISOFLOW ABSORPTION SYSTEM SOLUTION CONCENTRATION, AVERAGE IN SYSTEM SOLUTION CIRCUIT**

### Solution and Refrigerant Interchange During Operation

The absorption system accommodates varying loads and cooling water temperatures by varying the solution concentration in accordance with the representative concentration chart, Figure 11. The IsoFlow units carry sufficient reserve refrigerant (water) within the system to permit the load to drop to approximately 10% at a fixed cooling water temperature above about 75°F. Figure 11 indicates that the average solution concentration within the system would be approximately 50-51% for operation at these higher fixed cooling water temperatures.

- Solution and refrigerant variation with load variation at higher cooling water temperatures -** Table 1 illustrates, in a rough way, variation of refrigerant quantity in the refrigerant circuit, and

solution quantity in the solution circuit, as the percent load varies. The values shown are approximate only, and are to be taken only as indicating a general trend rather than a guide for absolute settings.

In Item 2, Table 1, it is noted that concentration leaving the absorber at 100% load is approximately 59.3%. At 25% load the concentration must drop, and would be in the order of 54.0%. By reducing the concentration, the capacity of the absorber falls off and thus the absorption system capacity is reduced.

This of course, as explained above, is brought about mainly by throttling of the steam valve, so that the concentration leaving the generator is as shown in Item 1, where the concentration drops from 64.3% at peak capacity to approximately 59.0% at the 25% load condition.

Item 3 shows rough average solution concentration throughout the entire system.

**TABLE 1 – PART LOAD OPERATION – APPROXIMATE VALUES ONLY**

LOAD%	25%	50%	75%	100%
Solution Concentration				
1 Leaving Generator	59	61	63	64.3
2 Leaving Absorber	54	56	58	59.3
3 System Average	56	58	60	62.0
Per Drum of Solution				
4 Lbs.	221	212	212	212
5 Lbs. Water in Solution	167	154	142	129
6 Total Weight In Solution	379	366	354	341
7 Water Driven Off, Lbs.	21	34	46	59
Generator Operation				
8 Solution Temp. Leaving. Gen.	167	184	201	210
9 Steam Pressure, PSIG	1	1	2	9

A change in concentration from an average of 64% at 100% load, to approximate value of 56% at 25% load, brings about marked changes in the quantity of solution and refrigerant in circulation. For each 400 pound drum of solution charged into the system at 53% concentration, there is correspondingly 212 pounds of lithium bromide and 188 pounds of water charged into the system. As steam is applied, and water vapor is driven from the solution, there is

a reduction in water content as shown in Item 5. At 100% capacity, only 129 pounds of water would still exist in the drum of solution as charged into the system. Item 6 shows that the total weight of solution would then be 341 pounds, for each drum charged into the system, and that 59 pounds of water would have been driven off.

Figure 12 shows in a rough way what happens to refrigerant and solution levels as the system capacity changes. The top view shows the levels in the lower shell at 25% load. Much of the water is back in the solution, so the solution level is correspondingly high in the bottom of the shell. The refrigerant level in the refrigerant drain pan, however, is relatively low. On the bottom view, also showing the lower shell, but at a 100% load condition, much of the refrigerant has been driven from the solution, and consequently the volume of solution in the bottom shell is reduced. At the same time there is more refrigerant in the refrigerant circuit and the evaporator drain pan level is consequently high.

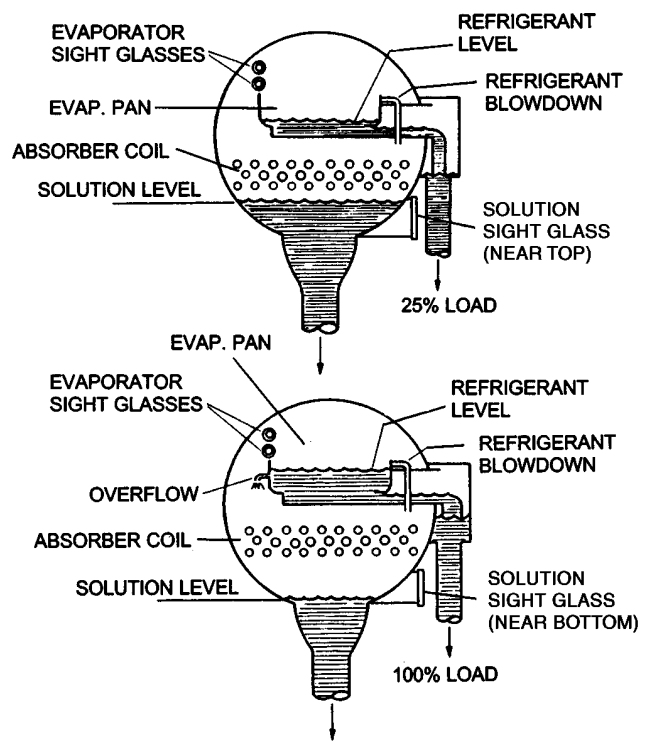

LD04766

**FIG. 12 – SOLUTION AND REFRIGERANT LEVEL VARIATION WITH LOAD**

**Refrigerant Overflow** – An auxiliary refrigerant overflow pan is located near the tube sheet in such a way that it can be witnessed through the evaporator sight glasses.

Since the amount of refrigerant in the refrigerant circuit is at a maximum of 100% capacity, overflow would normally start to take place at the 100% condition or slightly above. **This overflow and sight glass arrangement therefore provides a method of charging the correct amount of refrigerant into the system, provided 100% load is obtainable. Add refrigerant to the system until the evaporator pan is at the point of overflow at this 100% load. Charging to this condition has the added advantage of providing a safety feature against over-concentration.** Any tendency to over-concentrate, as might be the case if the absorber section operation is faulty (such as with air in the system), would be prevented to some degree by overflow refrigerant into the solution.

**Absorber Solution Level** – A large sight glass is provided near the bottom of the absorber shell to observe the dilute solution level in the absorber. At steady full load conditions, the level in the absorber will be at its lowest, since the maximum amount of water (removed from the solution) will be in the refrigerant circuit. Under these conditions, the level in the sight glass should be just visible at the bottom of the sight glass. As the load decreases, less refrigerant is generated out of solution and the level in the absorber will increase until (at very light loads) the level in the absorber is at its maximum (near the top of the sight glass).

If there is any doubt whether the unit is operating normally, a solution concentration check will indicate whether excessively high solution concentrations are being encountered.

2. **Solution and refrigerant variation with load variations at lower cooling water temperatures** – IsoFlow systems are equipped with provisions to accommodate low load operation (down to 10%) with cooling water temperature as low as 45°F.

Referring again to Figure 11, achievement of low capacity at low cooling water temperature involves reduction of concentration in the solution circuit. YORK is able to achieve considerable reduction of concentration of solution by generous use of additional refrigerant in the basic design. Thus, water is removed from the refrigerant circuit and is added to the solution circuit for dilution. In the IsoFlow design, further dilution is brought about by removal

of lithium bromide from the solution circuit, sending this lithium bromide under a controlled basis to the refrigerant circuit, for unlimited capacity control possibilities.

The amount of actual lithium bromide transferred is kept to a minimum by introducing this lithium bromide only when the refrigerant level in the refrigerant circuit is at a minimum operational level, at which time float switch 1F signals 3SOL to open and transfer solution to the refrigerant pump circuit.

During normal summer operation where at least medium load prevails, lithium bromide transfer to the refrigerant circuit is not required and the YIA panel prevents transfer of solution at possible low refrigerant level at startup. The function blocks out operation of 3SOL until the chilled water temperature is within range of normal operation.

To provide for lithium bromide removal from the refrigerant circuit as the system proceeds from low load, low condensing water temperatures to higher load, higher condensing water temperatures, the system automatically transfers the lithium bromide from the refrigerant circuit, using a combination of various means.

1. To assist in the lithium bromide removal from the refrigerant circuit as required under increasing load conditions, the IsoFlow design utilizes on its standard unit a small amount of continuous refrigerant blowdown.
2. The action of the system stabilizer (refrigerant valve 2SOL) has the effect of transferring from the refrigerant circuit.
3. At high loads and high condensing water temperatures approaching design conditions, any residual in the refrigerant circuit will be removed by a temporary evaporator pan overflow, if the lithium bromide has not previously been removed by the combination of the continuous blowdown and action of 2SOL.
4. The refrigerant is gradually purified as refrigerant condensate makeup is accelerated with the increase in load and cooling water temperature.

When it is desired to reduce the content of lithium bromide in the refrigerant circuit more rapidly than would automatically occur, the service engineer can enter the electronic panel and energize 2SOL manually.

It should be noted that the conditions during which the lithium bromide content appears high are at low load and low cooling water temperature, at which time the evaporator pan is essentially empty and the

need for the more efficient evaporation is insignificant. At higher loads and cooling water temperature, the evaporator automatically becomes totally efficient.

### **ANTI-FREEZE LINE**

For sustained operation at low loads and low condensing water temperature, the concentration of lithium bromide by weight in the refrigerant circuit may approach 35% - 40%. With conditions such as these, the pressures in the lower shell are reduced. The pure water refrigerant entering the evaporator from the condenser would at these times be below the freezing point of water (32°F) by as much as 12%, and could cause ice to hang up in the refrigerant condensate lines from the condenser after the orifices.

To prevent this, a small amount of refrigerant (actually very dilute solution now in the refrigerant circuit) is routed from the discharge of the refrigerant pump to mix with the pure water refrigerant about to enter the evaporator from the condenser. This line is identified on the cycle diagram Figure 10 as the antifreeze line.

### **Chilled Water Control Stability**

Operation of an absorption system without the tower water bypass valve control to maintain a given cooling water temperature to a unit requires certain control measures within the unit to maintain acceptable stability of operation. The effect of rapidly changing tower water temperature, such as occurs when tower fans cycle off and on, would affect the unit capacity control, causing steam valve opening and closing tendencies to cut-out on refrigerant low temperature thermostat if provisions were not made to offset these tendencies.

### **Stabilizer Refrigerant Solenoid (2SOL)**

IsoFlow units are equipped with a control stabilizer arrangement. This control operates the refrigerant valve (2SOL) to permit immediate transfer of refrigerant to the generator drain line for immediate control of refrigerant temperature, via dilution of the solution and hence, reduction of absorption and refrigeration effect. This type of action, when necessitated by influences of cooling water temperature fluctuations, corrects the low temperature condition, permits refrigeration effect to continue, and restrains from appreciably unloading the cooling tower such that an aggravated cooling water temperature swing is avoided.

### **Capacity Control Valve Override**

Under startup conditions, and again during normal operation with changing load or changing cooling water temperatures, a signal may be sent to the capacity control valve for maximum opening, simultaneous with a relatively low cooling water temperature. An unnecessarily high solution concentration and excessive violent action in the generator can result. IsoFlow units provide an override control, to automatically reduce the maximum setting of the steam valve related to cooling water temperature.

### **Automatic Decrystallization Control**

The operation of units with the ADC control circuit is described in detail in the section "Discussion of Sub-System Operation" below.

## **DISCUSSION OF SUBSYSTEM OPERATION**

### **Automatic Decrystallization Feature**

Units can crystallize when the concentration of lithium bromide is excessive for a given temperature. This could happen in the shell-side of the heat exchanger and could extend to the piping and the eductor, causing stoppage of flow and producing a noisy condition. The automatic decrystallization feature is available on all IsoFlow Absorption Systems. All models are equipped with this basic ADC piping circuit plus the ADC control feature.

The automatic decrystallization feature is a valuable asset in striving for trouble-free operation. While the ADC piping circuit will not completely eliminate the possibility of a condition of crystallization requiring service assistance, it will greatly reduce the likelihood. A tendency for mild temporary crystallization which might occur in rather extreme condensing water temperature variations can be automatically taken care of without loss of refrigeration or special attention from the operator. Still more positive measures attacking the major factors in solution crystallization are taken in models where the ADC controls are utilized. Direct dilution of the solution with refrigerant and reducing the heat input to the generator when the tendency to crystallize is automatically detected are both affected by ADC controls, arranged to continue in effect until the tendency to crystallize disappears.

### Basic Automatic Decrystallization Piping Circuit

Referring to Figure 13, the normal return solution flow from the generator is by way of return pipe (1), through heat exchanger (2), and hence through pipe (3) to the eductor suction (4).

During normal operation, the flow of solution in return pipe (1) is accomplished by a condition of “open-sewer” flow for a portion of the return pipe from (A) to (B). Below some point (B) a solid liquid level is established and solid liquid exists from (B) through the heat exchanger (2) and return pipe (3).

If a situation starts to develop such that solution concentration from the generator is excessively high, solution crystals will start to build on the shell side of the heat exchanger. This will restrict the flow through the normal system of return piping above described, and the established solution level (B) will rise in the return pipe (1). This will continue to rise until an elevation (C) is reached. At this point, an emergency solution return pipe is provided. This return pipe is item (9), with connection entering the return piping at (8). This return pipe (9), has a trapped section of pipe (10), riser portion (11), and pipe sections (12) and (13).

The heat exchanger is therefore bypassed in the operational use of this emergency return system of piping. Its operation is completely automatic.

It should be noted that as crystallization proceeds, it is not necessary for the solution to back up into the generator itself to engage the use of this device. It is desirable to bring the device into operation before an extreme condition of crystallization is experienced. Connection (8) therefore enters the normal return piping at a level appreciably below the normal generator operating level (17). Since this enters the return piping at a point where there is open sewer flow, there is no flow of solution down this emergency decrystallization pipe during normal operation.

It is necessary that this automatic decrystallization pipe contain a liquid trap. Otherwise, there would be unwanted flow of vapor from the top shell to the lower shell due to the difference in pressures between the two shells.

### ADC Flush Line

To provide a liquid trap, a small capacity flush line is provided (14), to supply a small GPM flow of dilute solution into the trapped portion of the decrystallization pipe. It is desirable that the riser portion of this trap be sufficiently high to take care of any extreme condition in top shell pressure, such as with unusually high condensing water temperature and degree of condenser fouling.

Consequently, a riser portion is extended up into exterior pipe (12). This pipe (11) inside pipe (12) is an extension of pipe (10).

This flow of flush solution through the trap also serves the purpose of sweeping out the small amount of water condensate that tends to be absorbed into the dilute solution at the liquid-vapor interface.

In the operation of the unit, one can easily tell whether the solution flow from the generator is by normal return methods through the heat exchanger, or whether the automatic decrystallization pipe is being used. By placing the hand on pipe (10), or pipe (13), a hot temperature such as that normally experienced at pipe (1) would indicate that solution is returning by means of the automatic decrystallization pipe. A relatively low temperature, corresponding to normal temperature of dilute solution or slightly above, would indicate that there is no return flow through the automatic decrystallization pipe.

### Combination of Basic ADC Piping Circuit and ADC Control Feature (See Figure 13)

The basic ADC piping circuit is installed and brought into play and operates the very same way in this application as described above. The additional protection afforded by the ADC Controls feature is therefore discussed here.

As hot concentrated solution backs up and overflows into emergency solution return line (9), the temperature of the pipe increases and the ADC sensor item (18), attached to the pipe, senses this temperature. At a temperature of approximately 160°F, item (18) starts a control panel timer, which signals the capacity control valve (23) to close to 50% for a minimum of 10 minutes. During the first 2 minutes, 2SOL (Item 16) is energized

to permit refrigerant to be pumped into line (1) via connection (15). The cycle will be repeated until line (8) cools to approximately 150°F, or lower, signifying easement of the crystallization condition and normal circulation of solution from the generator such that overflow into line (9) has ceased.

It must be noted that the ADC operation will continue for at least 10 minutes regardless of a shutdown or subsequent restart.

### 2SOL – Refrigerant Valve Blowdown

Manual operation of the refrigerant valve (2SOL) may be selected by using the manual pump key in the Program mode. When this valve is energized, refrigerant will flow through the line, into the shell side of the heat exchanger and ultimately into the absorber shell, thus transferring refrigerant back into the solution side of the system.

#### LEGEND TO FIG. 13

ITEM NO.	DESCRIPTION
1	SOLUTION RETURN PIPE
2	SOLUTION HEAT EXCHANGER
3	EDUCTOR SUCTION
4	EDUCTOR
5	SOLUTION PUMP SUCTION
6	SOLUTION PUMP DISCHARGE
7	GENERATOR SUPPLY LINE
8	A.D.C. PIPE OVERFLOW CONNECTION
9	A.D.C. PIPE
10	A.D.C. PIPE (TRAPPED SECTION)
11	A.D.C. PIPE (RISER SECTION)
12	A.D.C. OVERFLOW JACKET

ITEM NO.	DESCRIPTION
13	A.D.C. OVERFLOW DUMP LINE
14	A.D.C. FLUSH LINE
15	REFRIGERANT VALVE CONNECTION
16	REFRIGERANT VALVE (2SOL)
17	SOLUTION LEVEL IN GENERATOR
18	A.D.C. THERMOSTAT (RT2)
19	CAPACITY CONTROL VALVE
A	START OF OPEN SEWER FLOW
B	TOP OF SOLID LIQUID LEVEL
C	A.D.C. SOLUTION OVERFLOW POINT

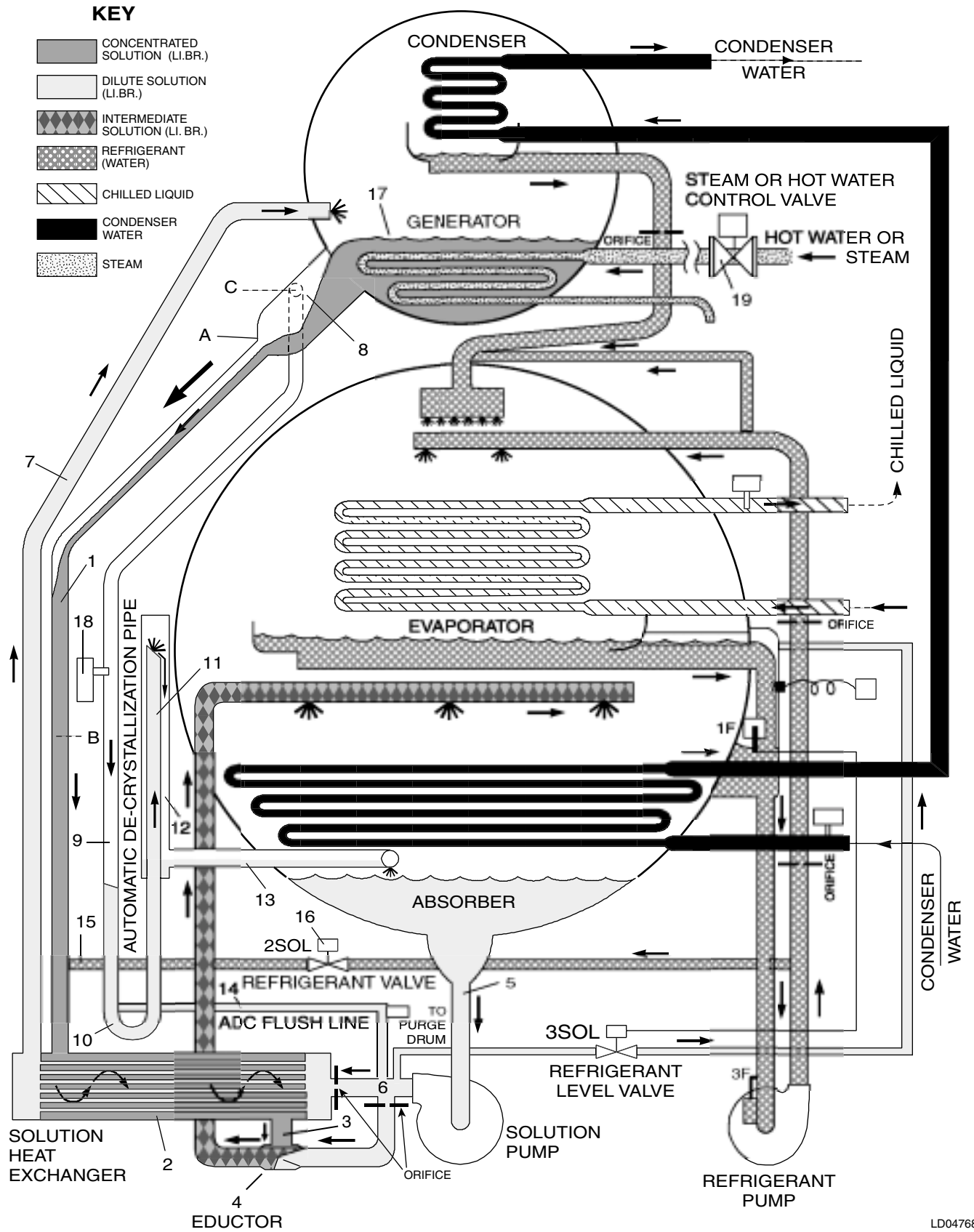

**Note:** Orifices may differ between various models.

**FIG. 13 – AUTOMATIC DECRYSTALLIZATION FEATURE (HOT WATER UNITS & STEAM UNITS WITH ADC CONTROL)**

## SECTION 3 – PURGE SYSTEM OPERATION (Refer To Figure 15)

Each system is equipped with a purge pump for removing any air and other noncondensable gases from the system. A **minimum** purging sequence of once per week is recommended.

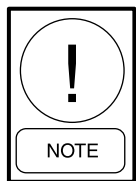

***Do not operate purge pump until pump has been properly charged with DUOSEAL Purge Pump Oil.***

***Do not operate purge pump during warming or cooling operations to correct a severely crystallized unit.***

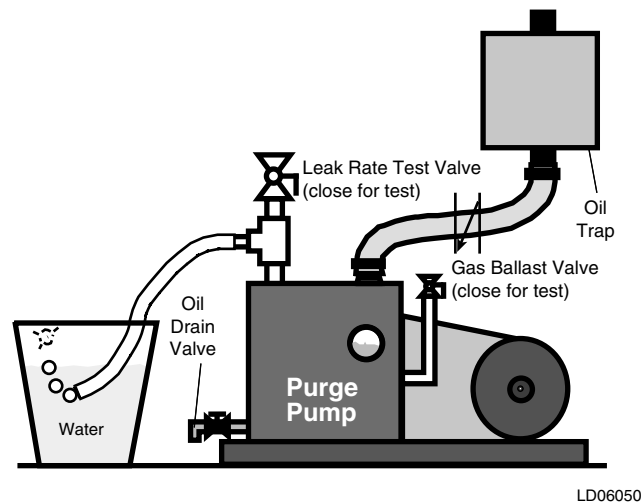

The purge system is operated as follows:

1. Start the Purge pump through the control panel. Run the pump for 10 minutes with the gas ballast valve open and check the vacuum on the gauge. It must be 2mm Hg or less.
2. Establish the leakage rate of the purge pump and the unit using the bubble test procedure, Fig. 14.
  - a. Purge Pump - After reading the 1-2mmHg of mercury vacuum that the pump is capable of attaining, close the ballast valve and the leak rate test valve. Place the hose from the discharge of the pump into a small container of water. Insert the tube approximately 1/4" in the water. Wait about 5 minutes to allow all residual air in the pump to be removed. Then count the number of bubbles leaving the hose in 1 minute. There should be no more than 1 to 2 bubbles.
  - b. Unit - Without changing the position of the ballast valve, open the manual purge valve to the unit. Wait about 5 minutes before reading the unit bubble rate. Usually a quantity of non-condensables have accumulated in the purge drum prior to opening the unit valve. This allows them to be removed so you can obtain a more true reading of any leakage that exists in the unit.

Then open the ballast valve on the purge pump and purge unit for approximately 30 minutes. Close the manual purge valve on the unit and let the purge pump run for 30 minutes. This will help to remove any condensation that became entrained in the oil, cleaning it up. If this clean-up period is not followed, the oil will have to be changed more often to maintain pump efficiency.

**FIG. 14 – BUBBLE TESTING FOR LEAKS**

3. To verify the effects of the purging performed on the unit:
  - a. After clean-up sequence, close the ballast valve and proceed as mentioned in 2a. The purge pump rate should have returned to the same rate for the pump that you recorded earlier. If not, an oil change or more clean up time may be required.
  - b. If so, then open the unit manual hand valve. After waiting 5 minutes, read the unit bubble rate again. Bubble rate change from 2b to 3b equals the effect of purging.
  - c. Close the unit manual hand valve, remove discharge hose from container, and open the ballast valve. Stop vacuum pump via the control panel.
  - d. Repeat purging operation at each start up. Check unit bubble rate periodically to determine required frequency of purging. If excessive purging is required, the unit must be shut down. Contact the nearest YORK Field Representative.
  - e. If the purge pump fails to produce the desired vacuum, refer to the Purge Pump Maintenance section for details.

### FUNCTION

Since this type of chiller operates at very low levels of vacuum, if there is the slightest leak in the piping some non-condensables will infiltrate the system. When this happens, there is a purging system in place for removing these non-condensable materials.

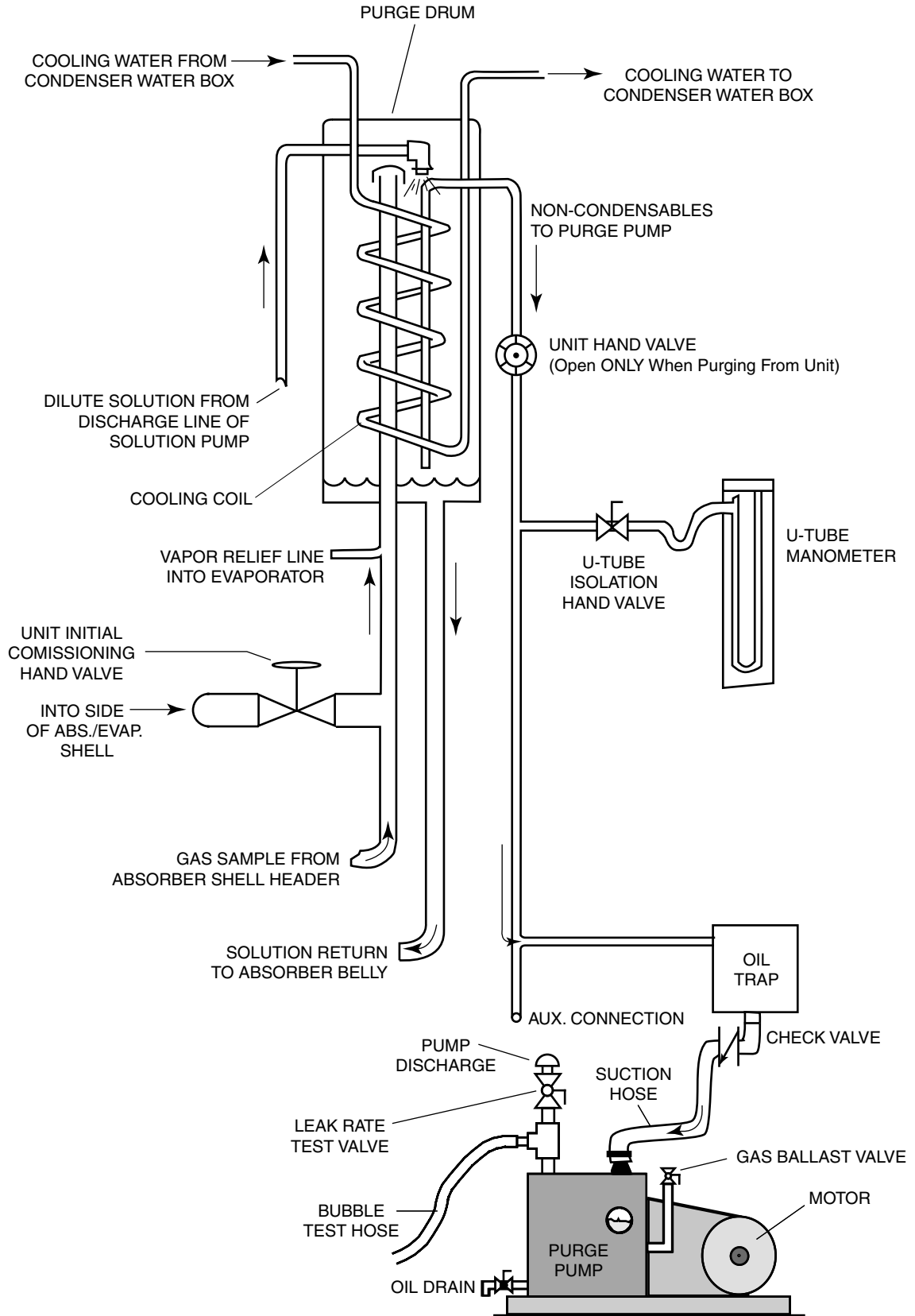

FIG. 15 – ISOFLOW PURGE SYSTEM

LD05998

The most common non-condensables found in the purge exhaust of an absorption-type chiller are as follows: nitrogen (N<sub>2</sub>), anhydrous ammonia (NH<sub>3</sub>), nitrous oxide (N<sub>2</sub>O), nitrogen dioxide (NO<sub>2</sub>), nitrogen tetroxide (N<sub>2</sub>O<sub>4</sub>), various other compounds of nitrogen, and hydrogen gas (H<sub>2</sub>). Keep in mind that on IsoFlow™ chillers with chromate inhibitor, none of these gases will be present.

### SYSTEM DETAILS

The system consists of a suction probe arrangement in the Purge Drum, spray header, cooling coil, and a vacuum pump, along with interconnecting piping.

In the Purge Drum, condenser water is circulated through a coil, thus inducing and absorbing water vapor and making it possible to pump a higher concentration of non-condensables from the system by means of the Purge Pump. Details of the innards of this Purge Drum can be seen in Fig. 16.

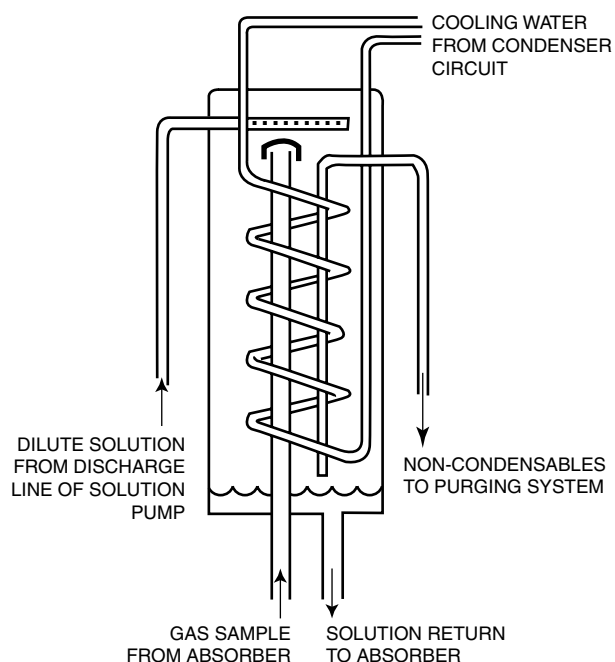

LD06026

FIG. 16 – PURGE DRUM DETAILS

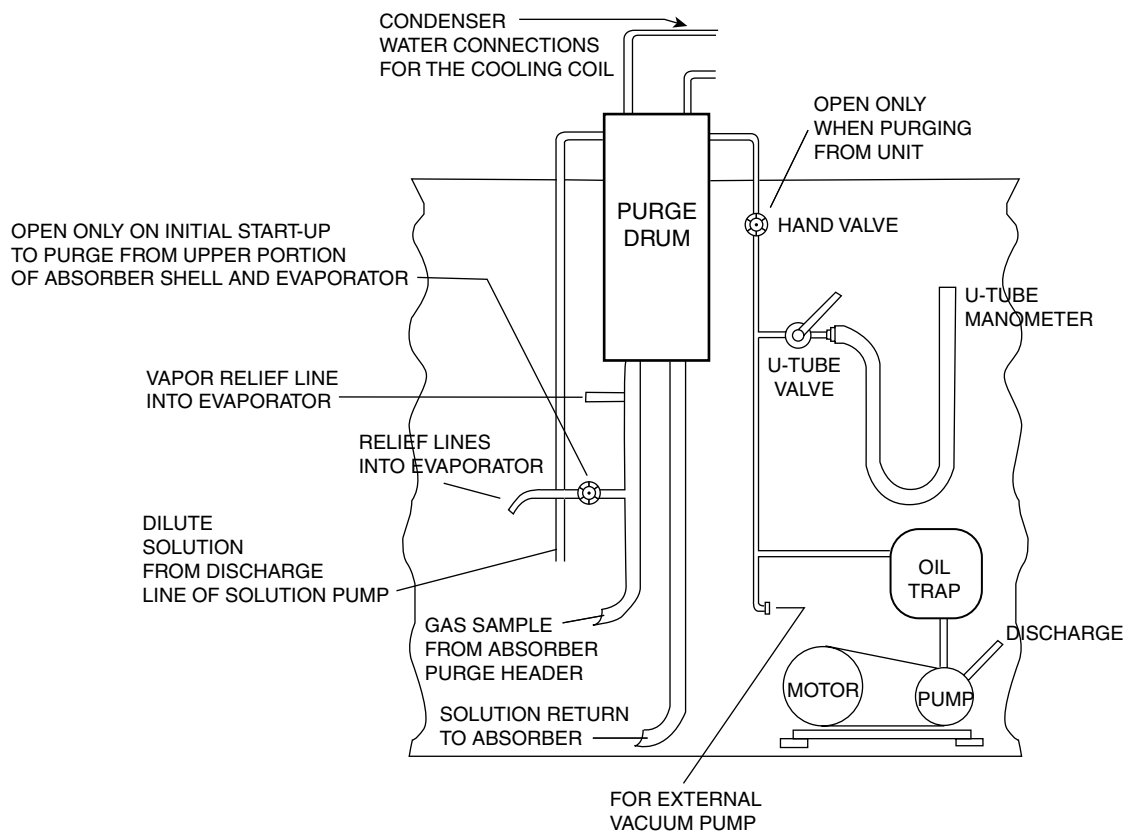

LD06027

FIG. 17 – THE COMPLETE PURGE SYSTEM

## SECTION 4 – PURGE PUMP OPERATION

### GENERAL

As previously discussed, each machine is equipped with a vacuum pump (refer to Fig. 19, for pump specifications) which is designed to remove non-condensables from various areas of the machine. The following issues should be kept in mind whenever operating a YORK Vacuum Pump.

#### Cleanliness

Take every precaution to prevent foreign particles from entering the pump. A fine mesh screen is provided for this purpose in the intake passage of all YORK Vacuum Pumps.

#### Types of Lubricants

All YORK mechanical vacuum pumps are tested with DUOSEAL® oil and shipped with a full charge to prevent unnecessary contamination. DUOSEAL® oil has been especially prepared and is ideally suited for use in mechanical vacuum pumps because of its desirable viscosity, low vapor pressure and chemical stability.

The vacuum guarantee on all YORK vacuum pumps applies only when DUOSEAL® oil is used.

#### PURGE PUMP PIPING AND OPERATING VALVES

The purge pump piping and valves, illustrated in Figure 15, is installed at the factory and can be used for several functions. During normal operation, both the gas ballast and the leak rate test valve must be open at all times.

#### The Principle of Gas Ballast

**The Effects of Unwanted Vapor** - Systems which contain undesirable vapors cause difficulty from both the standpoint of attaining desirable ultimate pressures, as well as contamination of the lubricating medium. A vapor is defined as the gaseous form of any substance which is usually a liquid or a solid. Refrigerant (water) and alcohol vapors are two of the most common vapors encountered in absorption chillers. When such vapors exist in a system, the vapors or mixtures of gas and vapor are subject to condensation within the pump. This precipitated liquid may dissolve or become emulsified with the oil. This emulsion is recirculated to the chambers of the pump where it is again volatilized, causing increased pressure within the system.

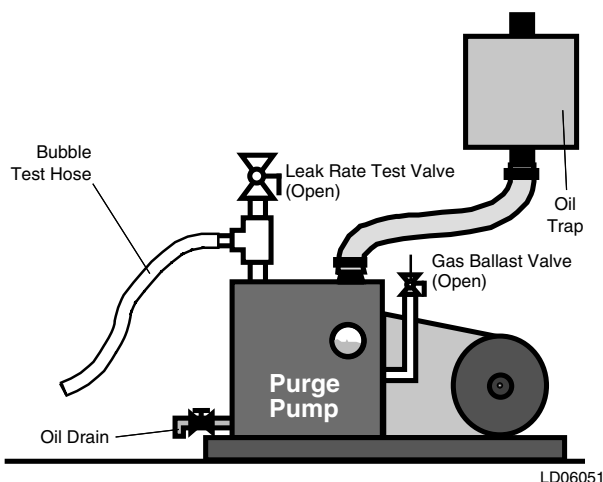

**FIG. 18 – PURGE PUMP PIPING AND VALVES - NORMAL OPERATION**

**The Presence and Removal of Condensate** - Condensation takes place particularly in the compression stroke of the second stage of a two-stage pump. The compression stroke is that portion of the cycle during which the gas drawn from the intake port is compressed to the pressure necessary to expel it past the exhaust valve. Condensation takes place when the ratio between the initial pressure and the end pressure of the compression is high, that is, when the mixture of vapor and gas drawn from the intake port is compressed from a low pressure to a high pressure. By adding air through the gas ballast valve to the mixture of vapor and gas being compressed, the pressure required for delivery past the exhaust valve is reached with a considerably smaller reduction of volume of the mixture; thus, depending upon the amount of air added, condensation of the vapor is either entirely avoided or substantially reduced.

#### OIL LEVEL DETERMINATION

The amount of oil suitable for efficient and satisfactory performance should be determined after the pump has reached its operating temperature. Initially, however, the pump should be filled with fresh oil while the pump is idle. Fill the pump through the pump discharge port until the oil level falls halfway up the oil level window. If after a short period of operation, the level should fall, it is likely the result of oil entering some of the interior pockets of the pump. If the oil level rises, this signifies oil had drained into the pump cavity while idle. Shut off pump, then drain oil down to proper level.

If a gurgling sound occurs, additional oil may need to be added. Mechanical pumps will gurgle in varying degrees under four conditions of performance: (1) when operating at high pressure as in the beginning cycles of evacuation of the purge drum; (2) when the oil level in the pump reservoir is lower than required;

(3) when a large leak is present in the system; and (4) when the gas ballast is open. Best performance of a mechanical pump is generally obtained after sufficient time has been allowed for the pump to come to operating temperature.

---

## SECTION 5 – PURGE PUMP MAINTENANCE

### VACUUM PROBLEMS

#### Pressure Determinations

A simple test for the condition of a mechanical pump is a determination of its ultimate pressure capability. This can be accomplished by attaching a gauge directly to the pump. The gauge may be any suitable type provided consideration is given to the limitations of the gauge being used. The pump must be capable of pulling a vacuum of at least 2 mmHg Abs. If the pressure is unusually high, the pump may be badly contaminated, low on oil or malfunctioning. On the other hand, if the pressure is only slightly higher than the guaranteed pressure of the pump, an oil change may be all that is required.

#### Oil Contamination

The most common cause of a loss in efficiency in a mechanical pump is contamination of oil. It is caused by condensation of water and alcohol vapors and by foreign particles. The undesirable condensate emulsifies with the oil which is recirculated and subjected to re-evaporation during the normal cycle of pump activity, thus reducing the ultimate vacuum attainable. Some foreign particles and vapors may form sludges with the oil, impair sealing and lubrication and cause eventual seizure. Although the gas ballast valve is helpful in removing vapors, especially water, it is not equally effective on all foreign substances; therefore, periodic oil changes are necessary to maintain efficient operation. The required frequency of changes will vary with the particular system.

The oil should be changed when it looks dirty, cloudy, milky, or when the pump is not capable of pulling below 2mmHg Abs.

### OIL CHANGES AND OIL LEVEL

#### Draining the Pump

An oil change is most easily accomplished when the pump is warm and the oil is less viscous. Use a container large enough for the oil in the particular pump. Stop the pump, and open the drain valve. A thorough job may be accomplished by tipping the pump slightly, if this is possible. The small residue remaining in the pump may be forced out by hand-rotating the pump pulley with the exhaust port partially closed and the intake port open. Closing the exhaust port completely under these conditions will create excessive pressure at the drain valve which may cause the oil being drained to splatter.

#### Flushing the Pump

This procedure should be performed whenever the performance of the pump is poor and simply changing the oil didn't correct this shortcoming.

1. Check the oil level.
  - a. If the oil level is well above the fill mark, this can indicate the pump has ingested lithium-bromide solution. Go to step 2.
  - b. If the oil level is even with the fill mark and you do NOT suspect lithium bromide solution has been ingested accidentally by the pump, run the pump for 15 minutes and allow the pump oil to warm up before going to step 2.
2. Turn off the motor for the vacuum pump. Drain the oil into a clear plastic container. Look for water settling to the bottom of the container. In some cases, an emulsion of oil and water can be seen between the oil and the water. If water is noticed, perform steps 3 through 5 several times until the oil comes out clear.

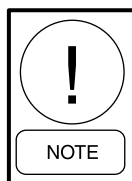

*The oil drained from the pump is from the oil case only. There may be water or other contaminants in the pumping mechanism. To be sure all contaminants have been removed, the pump mechanism needs to be flushed.*

3. Make sure the belt guard is installed before proceeding further. Attach a short hose to the drain valve which runs into a clear plastic container. Secure the hose end in the container so that it does not blow around during the next step.
4. Flushing the pump is carried out by adding a cup of new DUOSEAL® oil through the intake (IN) port while the pump is turned on for 15-20 seconds. While adding the pump oil, the exhaust (OUT) port is blocked by the palm of your hand. Look for water coming out of the drain hose. Turn off the pump.
5. Repeat step 4 until only clean oil comes out of the drain hose.
6. Fill the pump (through the exhaust port) with 2.25 quarts of DUOSEAL™ vacuum pump oil.
7. Plug the intake (IN) port with a rubber stopper. Turn the pump on and run the pump for 10 minutes. Close the gas ballast valve.
8. Check the vacuum reading of the pump by connecting a thermocouple or pirani gauge tube to the pump's intake. If the pump is running close to new, the total pressure reading should be at least 10 micron.

A simple way to connect the gauge tube to the pump is to run the threaded tip of the tube through a hole in the rubber stopper. Use pump oil as a lubricant for inserting the tube. The stopper chosen should be bigger than the outer diameter of the intake fitting.

### Refilling the Pump

Refill the pump by pouring new DUOSEAL® oil into the exhaust port. Fill to the indicated level and start the pump with the intake closed. A gurgling noise is characteristic when high pressure air is drawn through the pump. It should disappear quickly as the pressure within the pump is reduced. If gurgling continues (with gas ballast closed), add sufficient additional oil through the exhaust port until gurgling ceases.

### SHAFT SEAL REPLACEMENT

To replace the shaft seal of a pump, drain the oil and remove the pump pulley and key. Remove the screws securing the old seal and pry it loose with a screwdriver or similar wedge, being careful not to mar the surface of the pump body against which the seal fits. Discard the seal and its gasket, inspect all surfaces and repair any damages with a fine abrasive stone. Wipe all sealing areas clean and place a film of DUOSEAL® oil on both the shaft and the inside bore of the new shaft seal. Using a new gasket, carefully slide the new seal into position and center it on the shaft. It is not necessary to apply any sealant to the gasket. Tighten the mounting screws uniformly and refill the pump with DUOSEAL® oil. Follow instructions included in repair kit.

### REPAIRING OIL LEAKS

#### Location, Cause and Effect

Oil leaks may develop wherever two mating faces are sealed with a gasket. Such seams may fail as the result of deterioration of the gasket material, loosening of the screws caused by temperature variations, or improper care as the result of previous reassembly. Typical gasketed seams in a mechanical pump are located at the oil level window, the shaft seal, the oil drain and the mating faces of such mechanical surfaces as the intake chamber cover. The importance of a gasketed seam is determined principally by its function. If it is a vacuum seal, the ultimate performance of the pump is dependent upon it. If it is an oil seal, the pump may be operated satisfactorily for some time without loss of function. Eventually, of course, a great loss of oil may cause harmful damage.

#### Repairing Technique

An oil seam may be sealed by any of several methods. When an O-ring is employed, the surfaces of the O-ring and its groove should be wiped clean. If the O-ring is not badly deformed or scratched, it may be reused by sealing with a slight film of vacuum oil or vacuum grease. Thin composition gaskets are generally used for large irregularly shaped areas. A replacement joint of this type should be thoroughly cleaned of all previous gasket material and the mating surfaces cleaned of any nicks.

## DRIVE PROBLEMS



***When troubleshooting drive problems or checking belt tension, always shut-off and lock out power at the main disconnect switch.***

If for any reason the pump will not operate, turn off and lock out the power at the main circuit breaker or disconnect. Check the overload assembly and electrical connections. Remove the guard cover followed by the belt. Re-establish power to the pump. If the motor

operates properly try hand-rotating the pump in the proper direction with the pump intake port open. If both turn freely, then replace the belt and check the belt tension. The tension should be sufficient to drive the pump without visible slippage. Any greater tension will cause noise and possible damage to the bearings of both the motor and pump. Make certain that both pulley grooves are clean and free from oil. The pulleys must be fastened securely on their respective shafts, and in parallel alignment. Re-install the belt guard and check for proper operation and amperage.

Replace or re-build any defective components.

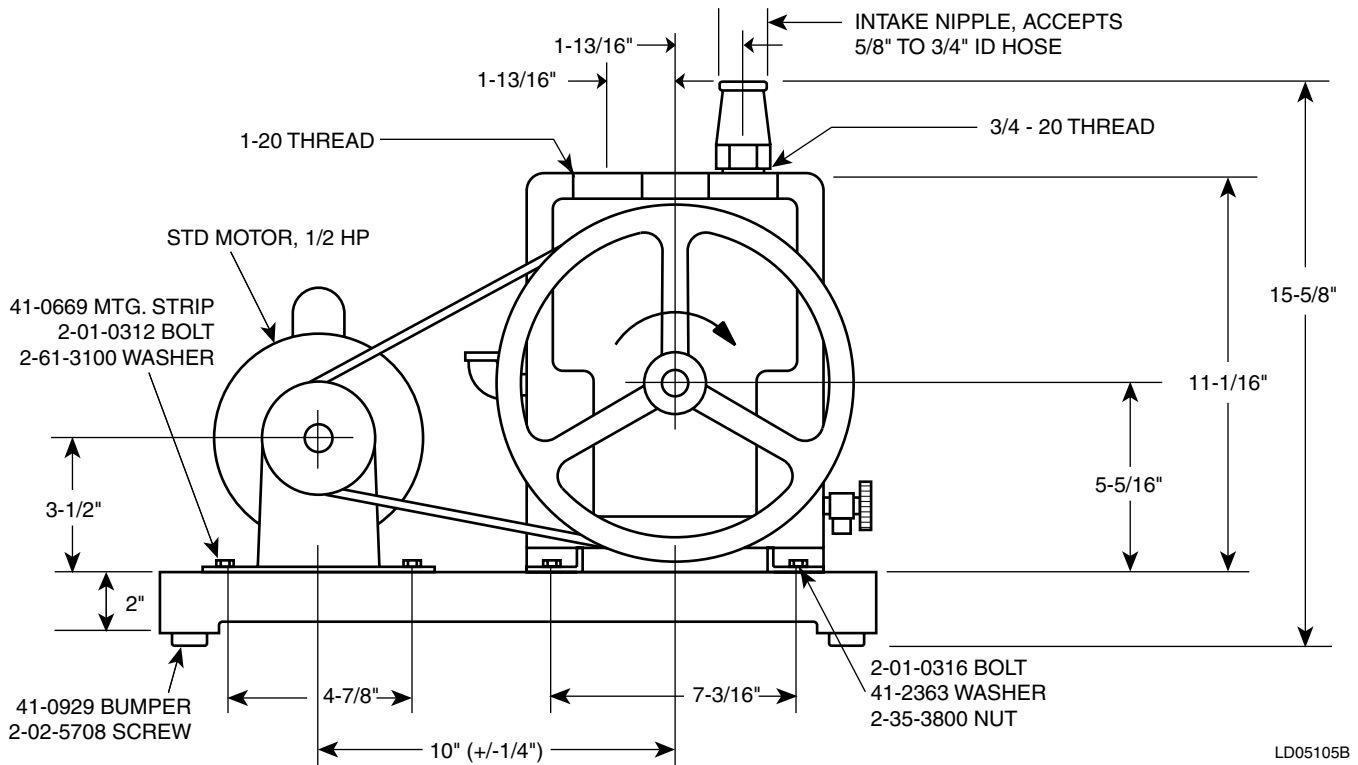
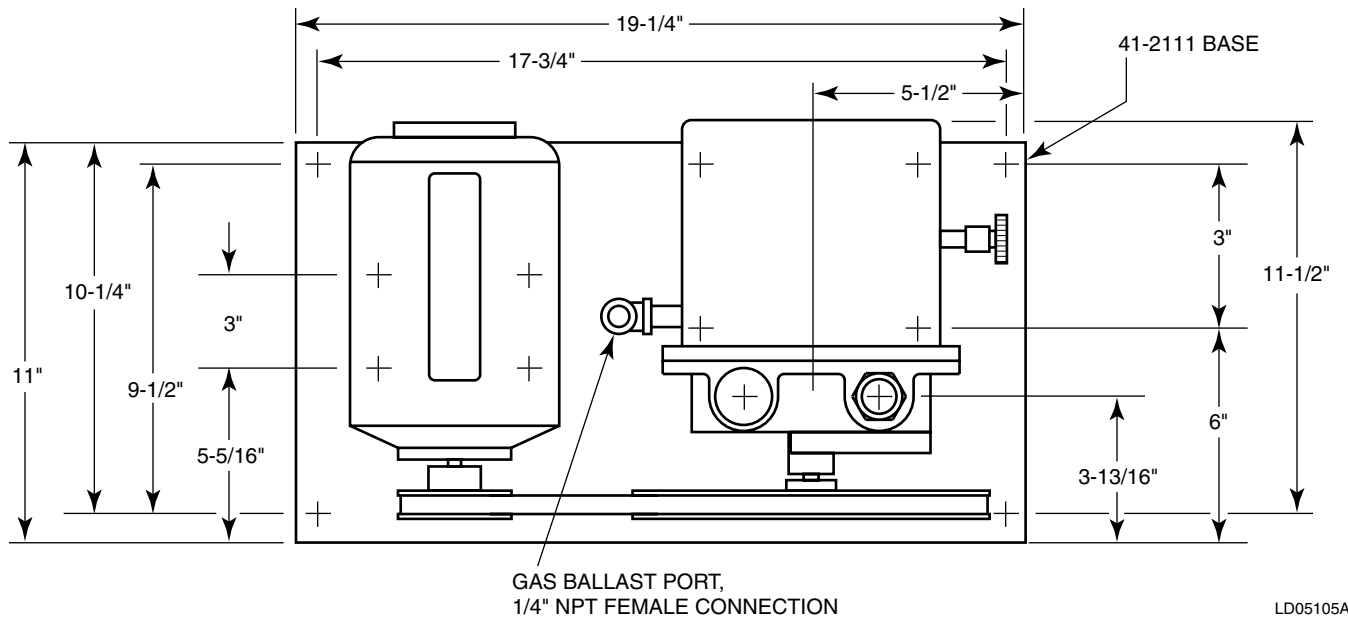

**SPECIFICATIONS:**

Free- Air Displacement, L/M	.160
CFM	.56
Guaranteed Partial Pressure	
Blankoff, millitorr	.01
Pump Rotational Speed, RPM	.525
Number of Stages	.2
Oil Capacity, qts	.2-1/4
Net Weight, Pump Only, lbs	.82
Net Weight, Mounted Pump, lbs	.112
Shipping Weight, Mounted Pump, lbs	.125

**FIG. 19 – MODEL 1402 VACUUM PUMP FOR YORK**

## SECTION 6 – BUFFALO PUMPS

### INTRODUCTION

The Buffalo pumps used on *IsoFlow™* chillers are single suction, single-stage, hermetically sealed centrifugal pumps designed for zero leakage, Totally Closed Liquid Cooled (TCLC). The pumps employ a unique spring-loaded conical bearing design that allows for long life between overhauls. The pump bearings are cooled and lubricated by the pumping fluid (refrigerant water or lithium bromide solution). The pumping liquid also carries away heat generated by the motor.



***Do not run the pump dry. Even momentary operation without the pump and motor casing filled with liquid will damage pump bearings.***

Figure 20 shows a cutaway view of a single-ended pump. The arrows indicate the cooling circuit through the pump.

### TROUBLESHOOTING

#### Pump Tripping on Overloads

Check voltage supply on all three phases to be sure it is correct for the pump motor in question. Check overload for proper amperage setting (Pump Motor FLA), loose wires or poor connections that generate heat and trip the overload. If no problems are found, shut off all power to the unit, lock out and tag all disconnects. Check the motor connections to be sure the pump is wired correctly. Using a megohm meter, check the pump motor windings for shorts or grounds. If motor problems are found, motor replacement will be necessary (Contact your local YORK Factory Service office for details). If no problems are found during this procedure, reconnect the motor. Apply power to the unit and run the pump, while watching the operating amps. If high amps are encountered, the problem may be mechanical, such as bearing seizure. Pump inspection will be necessary. If the overload continues to trip, but the motor amperage is within the allowable range, the overload is defective.

#### Pump Tripping on Thermal Protection

If the winding temperature thermostat is tripping the pump, allow the thermostat to reset. Exercise caution, the motor housing skin temperature should be in excess of 300°F (148.9°C) when the winding temperature thermostat trips. Although rare, if the thermostat will not reset in a reasonable period of time, it may be defective. If this is the case, temporarily bypass the thermostat and run the pump. Check the motor housing temperature with an infrared thermometer. The average outside skin temperature of a solution pump motor housing is 190°F (87.8°C) at stable operating conditions [100°F (37.8°C) Suction Temperature]. Refrigerant pumps run cooler than this. Check to be sure that the pump is not running dry periodically or that either the suction/discharge isolation valves are closed. Check to see that the pump is not pumping abnormally high-temperature liquid for some reason. If no problems related to flow through the pump are found, the internal coolant passages may be blocked. Pump disassembly will be required (Contact your local YORK Factory Service office for details).

#### Unusual Noise/Vibration

Pumps will make some noise during normal operation. If pump is experiencing cavitation, the noise and vibration will be more severe. Abnormal sounds and vibration may be due to foreign material trapped in the coolant circuit and rubbing between the stator and rotor. Noise may also be a result of extreme bearing wear. Pump disassembly is required.

#### Pump Overhaul

The expected time span between Buffalo Pump overhauls on a properly maintained *IsoFlow™* unit should be between 50,000 and 60,000 hours. Pumps installed on units running with high amounts of suspended solids or high amounts of dissolved copper in the solution will suffer shorter lives. It is therefore recommended to install a solution filtration kit on the unit to remove the suspended solids and/or perform a copper removal procedure as indicated on the solution chemistry report. Contact your local YORK Factory Service office for details.

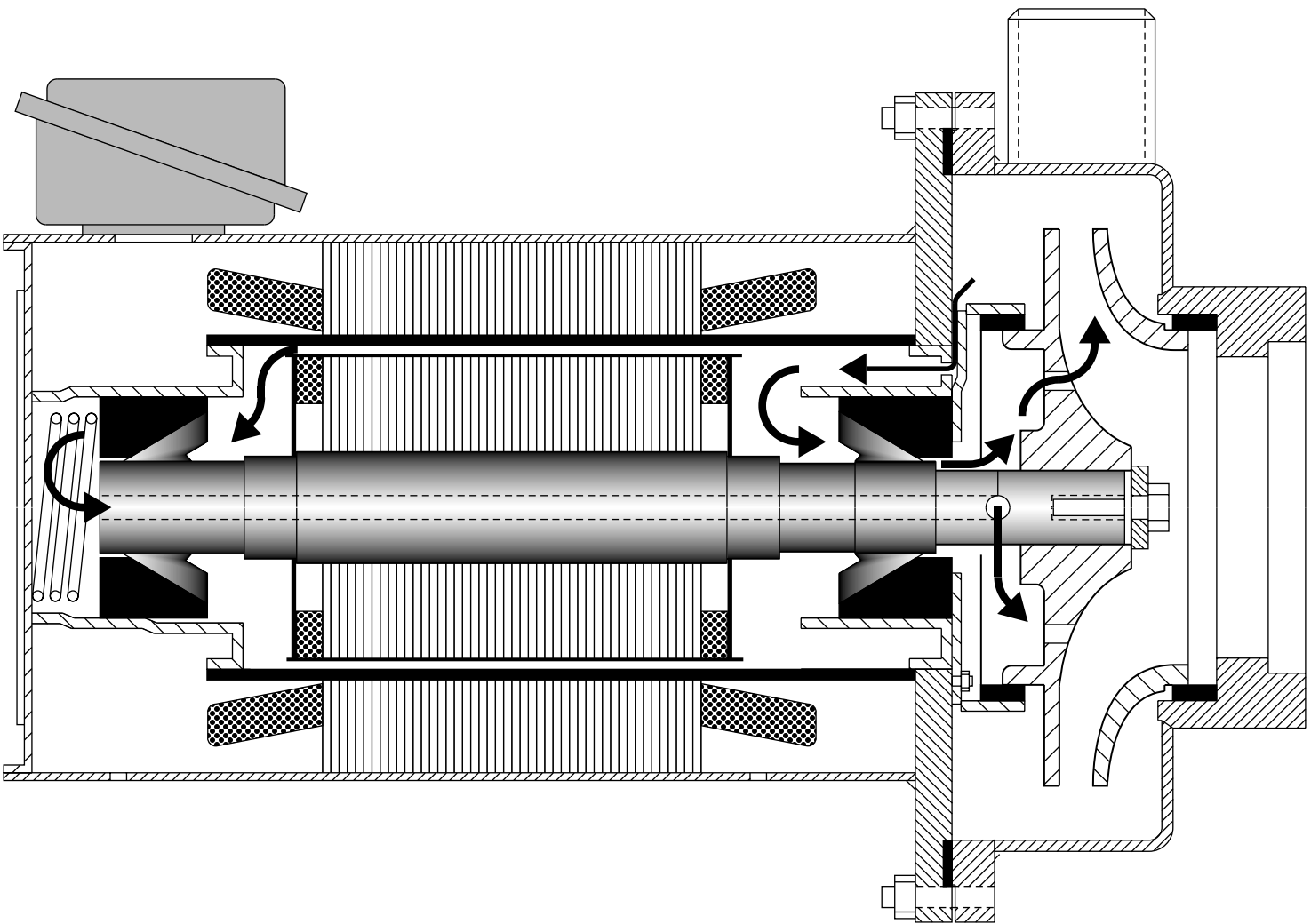

LD05106A

**FIG. 20 – FLOW OF REFRIGERANT WATER OR LITHIUM BROMIDE THROUGH PUMP**

## SECTION 7 – STEAM AND WATER QUALITY CONTROL

### GENERAL

Absorber/Condenser and Evaporator water must be free of corrosive species or inhibited to prevent attack of the waterside tubing. Impurities and dissolved solids can cause scaling that reduces heat exchanger efficiency and causes corrosion of tubes. Corrosion, in turn, can result in more serious problems, such as metal wastage and contamination of the solution and refrigerant if through-wall pitting occurs.

YORK IsoFlow™ Absorption Chillers can only deliver design output and efficiency if they are properly operated and maintained. One of the most important elements of proper maintenance is the cleanliness of the tubes to prevent fouling, scaling and corrosion during daily operations and shutdowns.

It is the responsibility of the owner (operator) of this equipment to engage the services of an experienced and reputable water treatment specialist for both the initial charging of the system and its continuous monitoring and treatment. Improperly treated or maintained water will result in decreased efficiency, high operating costs and premature failure due to waterside corrosion.

For water treatment programs to be acceptable, they must protect all exposed metal (i.e., carbon steel, copper and brass) from corrosive attack. The use of corrosion inhibitors must be effective at low concentrations, must not cause deposits on the metal surfaces, and must remain effective under a broad range of pH, temperature, water quality and heat flux. Furthermore, the inhibitor package must prevent scale formation and disperse deposits, while having a minimal environmental impact when discharged.

Water samples should be collected and analyzed on at least a monthly basis by the water treatment specialist. A quarterly review with the treatment supplier should address the conditions of the water systems and develop action plans based on these analyses. A third party water consulting company can help oversee the water treatment programs in order to properly protect the physical plant and avoid costly downtime.

It is equally important that the owner (operator) of the equipment performs tube cleaning and inspection of the absorber, condenser and evaporator waterside tubes at the frequencies recommended in the Tube Bundle Section of the "Preventive Maintenance Schedule" located in this manual. In addition to periodic cleaning with tube brushes, tubes must be inspected for wear and corrosion. Tube failures usually occur due to corrosion, erosion, and fatigue due to thermal stress. Eddy current analysis and visual inspection by boroscope of all tubes are invaluable preventative maintenance methods. These provide a quick method of determining waterside tube condition at a reasonable cost.

Your local YORK Service Representative will be more than happy to supply any or all of these services.

### STEAM/CONDENSATE OR HOT WATER QUALITY

IsoFlow™ units use corrosion resistant CuNi tubes in the generator.

As with the water side of the system, it is the responsibility of the owner (operator) of this equipment to engage the services of an experienced and reputable steam/condensate or hot water treatment specialist for both the initial charging of the system and its continuous monitoring and treatment. Improperly treated or maintained steam/condensate or hot water will result in decreased efficiency, high operating costs and premature failure due to steam/condensate or hot water side corrosion.

Steam/Condensate or hot water samples should be collected and analyzed on at least a monthly basis by the treatment specialist. A quarterly review with the treatment supplier should address the conditions of the steam systems and develop action plans based on these analyses. A third party consulting company can help oversee the treatment programs in order to properly protect the physical plant and avoid costly downtime.

It is equally important that the owner (operator) of the equipment performs an inspection of the generator tubes at the frequencies recommended in the Tube Bundle Section of the "Preventive Maintenance Schedule" located in this manual. In addition to periodic cleaning with tube brushes, tubes must be inspected for wear and corrosion. Tube failures usually occur due to corrosion, erosion, and fatigue due to thermal stress. Eddy current analysis and visual inspection by boroscope of all tubes are invaluable preventative maintenance methods. These provide a quick method of determining steam generator tube condition at a reasonable cost.

Your local YORK Service Representative will be more than happy to supply any or all of these services.

#### **TUBE CLEANING**

If during an inspection, scale is identified in any of the tube bundles, it will be necessary to remove this scale to prevent operational and or corrosion problems.

A build-up of scale on the tubes can cause a wide range of problems including:

- Reduced chilling capacity
- High solution concentration and crystallization.
- Pitting and corrosion of tubes
- Reduced efficiency.

The first step in trying to clean scales from tubes is to brush clean them. Only soft nylon brushes should be used, as damage to the copper or CuNi tubes will result if harder brushes (such as steel) are used.

If the brush cleaning is unsuccessful in removing all the scale from the tubes, it will be necessary to chemically clean them. An experienced and reputable contractor should be consulted. If the chemical cleaning is not performed properly, extensive tube damage may result.

## SECTION 8 – UNIT OPERATING PROCEDURES

### GENERAL

The YORK recommended installation of these absorption systems calls for complete automatic operation. The system and all of the auxiliaries are controlled by a switch on the control panel or by a remote control, such as a thermostat, time clock or other external control.

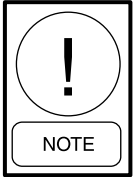

*It is recommended that Manual/Off/Automatic switches be used for control of the condensing water pump, the chilled water pump, and the tower fan motor. However, it is cautioned that the chilled water pump and the condensing water pump must always be operating when the unit is operating, and are thus preferred in the "Automatic" position. This is necessary to (1) provide proper dilution of the solution, thus protecting against crystallization during shutdown, and (2) to avoid freezing up the evaporator tubes during unit operation, including the dilution cycle operation during which refrigeration effect still occurs.*

### START-UP (NORMAL)

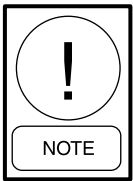

*This start-up covers units that have previously been started.*

See Form 155.16-O3, "Control Panel Operators Manual" for detailed instruction on how to operate the panel.

If the chiller has been idle for a long period of time, such as at the first start-up of the cooling season, it will be necessary to check the internal pressure of the unit to ensure a smooth start-up. To do this, see the Purge section of this manual.

Refer to the chart in Fig. 21 to compare the saturation pressure within the unit to the equivalent plant room temperature. If the measured internal unit pressure is within the shaded area of the chart, the start-up may continue. If not, purge the unit until the internal unit pressure reaches the shaded area of the chart.

Open the main shut-off valves in condensing water, chilled water, and steam or hot water supply lines to the system.

Close all disconnect switches to the control panel, the cooling water pump, chilled water pump, and tower fans.

Place the condensing water pump, chilled water pump, and tower fan switches in the "Automatic" position. (If manual operation is required for special considerations, refer to the NOTE under General).

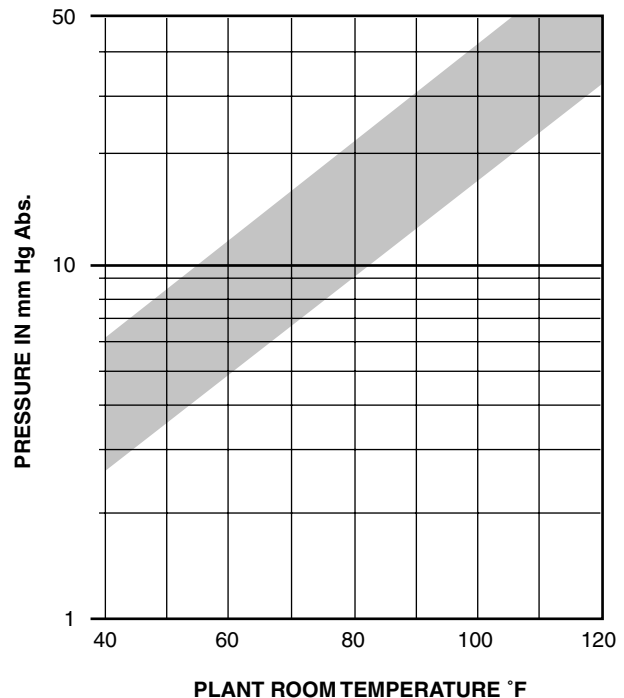

LD06021

**FIG. 21 – ACCEPTABLE INTERNAL UNIT PRESSURES**

## SHUTDOWN (NORMAL)

### Manual Shutdown (local operation)

See Form 155.16-O3, "Control Panel Operation".

Move the Unit switch from the RUN to the STOP/RESET position.

The Control valve will close and the unit will go into a dilution cycle.

As there are many types of unit shutdowns possible, please refer to Form 155.16-O3, "Control Panel Operation" for a description of each.

## OPERATING DATA

### General

A complete set of data on operating temperatures and pressures should be recorded for the unit regularly (every week is suggested as optimum). The purpose is to permit early recognition of an abnormal condition or trend that requires corrective maintenance, before serious damage occurs to the unit. Daily observation of the unit is useful to disclose any sudden changes.

All measurements that are recorded should be taken as simultaneously as possible with a steady load and a steady cooling tower water temperature, near the design conditions. A progressive gradual deterioration in unit performance is an indication that scaling is occurring, that there is a gradual buildup of inerts or that there is a malfunction of controls. It is mandatory that all performance analyses be based on date, and taken on units that are free of leaks. Otherwise, the lithium bromide concentrations and the steam pressure and steam flow requirements for a given load, as well as a complete set of operating temperatures, will be abnormal.

A thorough check of system performance, including sampling of the unit fluids, requires the services of a YORK Field Service Representative. He will take samples of the refrigerant, the lithium bromide charge, and the cooling water, as well as a complete set of operating data. He can assist in a complete per-

formance analysis and report on the condition of the unit. Samples can be analyzed and a complete report obtained on the chemical content and pH levels. The investment by the customer in the cost of these services is nominal compared to the cost of the unit and the ultimate cost of repairs or increased operating costs, should the unit be inadequately maintained.

Inadvertent introduction of air into the unit by the operator or the existence of leaks are to be avoided at all times for the attainment of long life of the unit. The proper method of taking samples is tedious and requires special training so that conclusions reached concerning the condition of the unit, the solution chemistry and the cooling water are valid.

For greatest accuracy of the data taken on operating units, calibrated 1/5°F increment thermometers should be used, particularly for measuring temperatures of chilled water and cooling water. Calibrated test type pressure gauges and manometers also contribute to the attainment of accurate data. Accurate flow meters for water and steam condensate flow (with a subcooler) complete the instrumentation requirements for the attainment of an accurate heat balance. This instrumentation is not normally available in the field. However, it can be obtained by special arrangements.

Nevertheless, a measure of the trend of system performance can be obtained by the systematic measurement of data taken with instrumentation normally available in the field. In all cases, however, any analysis is only as good as the degree of accuracy of the data taken. A steady state of operating conditions with all readings taken as simultaneously as possible, assists in obtaining valid data. All thermometers and pressure measuring devices should be calibrated so that readings are corrected to the true values. Insulation placed around the pipe and the outside well will improve the accuracy and validity of readings.

With the assumption that all data taken are accurate and valid, the following method of analysis for system performance is recommended.

## Performance Data and Calculations

Refer to the sample operating data sheet in Figure 22. This data is simulated by a computer for a YIA-6C4 unit with nominal passes. The assumed operating condition is 80% of the design load rating with assumed fouling factors of .0005, .001 and .0015 in the absorber and condenser, but with .0005 in the evaporator tubes. The effect of fouling on all readings is readily apparent. This data also assumes that the 2-Ethyl-1-Hexanol additive is present in the unit at the proper concentration to promote optimum shell side coefficients of heat transfer. This additive is charged into the unit upon initial start-up, and rarely does more Hexanol have to be added. The effect of Hexanol additive on unit performance appears later in this section.

The design load rating for the YIA-6C4 unit used for the data simulation is as follows:

100% Design Load	517.9 Tons
Condenser Water Flow	1870 GPM
Entering Condenser Water Temp	85°F
Chilled Water Flow	1243 GPM
Chilled Water Range	54°F to 44°F
Passes - Chiller/Condenser/Absorber	2/1/1
Fouling Factor for Absorber, Condenser and Evaporator	.0005
Steam Pressure at Generator	9.2 PSIG
Steam Flow	9478 lb/hr
Valve Inlet Steam Pressure	12PSIG = 299°F
Normal Installation Ambient Pressure	29.5" Hg (14.5 PSIA)
Steam Source	15PSIG @ 300°F

Assume steam condensate is flashed at atmospheric pressure before it is weighed for test data purposes.

YORK LITHIUM BROMIDE ABSORPTION SYSTEM

MODEL Y1A-6C4A SERIAL NO. \_\_\_\_\_ ORDER NO. \_\_\_\_\_ TEST NO. \_\_\_\_\_  
 NAME XYZ CO. ADDRESS \_\_\_\_\_ SHEET NO. \_\_\_\_\_  
 REMARKS 2 PASS CHILLER, 1 PASS ABSORBER, 1 PASS CONDENSER TESTER \_\_\_\_\_

SCALE FACTORS:				
CHILLER		.0005	.0005	.0005
ABSORBER/CONDENSER		.0005	.001	.0015
AMBIENT PRESS. "HG.		29.7	29.5	29.8
DATE		3/1/72	9/1/72	3/1/73
RUN NUMBER		1	2	3
CHILLED WATER				
1	ENTERING TEMPERATURE °F	51.99	51.99	51.99
2	LEAVING TEMPERATURE °F	44.0	44.0	44.0
3	PRESSURE DROP PSI	15.6	15.6	15.6
4	FLOW GPM	1243	1243	1243
CONDENSING WATER				
5	TO ABSORBER °F	85	85	85
6	TO CONDENSER °F	92	92.2	92.3
7	FROM CONDENSER °F	97.93	98.13	98.23
8	ABSORBER PD PSI			
9	ABSORBER FLOW GPM	1870	1870	1870
10	COND. & ABS. PD PSI	6.93	7.0	7.08
11	CONDENSER FLOW GPM	1870	1870	1870
STEAM				
12	PRESSURE PSIG	1.7	5.3	9.9
13	TEMPERATURE °F	295	296	298
14	CONDENSATE TEMP. °F	217.3	227.6	238
15	FLOW MEASURED LB/HR	7150	7280	7400
HOT WATER				
16	SUPPLY TO GENERATOR °F			
17	FROM GENERATOR °F			
18	RETURN °F			
REFRIGERANT TEMPERATURE				
19	FROM CONDENSER °F	104.9	110.9	117
20	CHILLER SPRAYS/PUMP SUCT. °F	41.6	41.6	41.6
21	ABSORBER PRESSURE MM. HG.	6.4	6.4	6.4
SOLUTION TEMPERATURE				
22	FROM ABSORBER °F	98.1	99.9	101.3
23	TO GENERATOR °F	160.1	167.3	174
24	FROM GENERATOR °F	192	203.2	213
25	CONN. FROM HEAT EXCH. °F	122.5	126.4	130
26	TO SPRAYS °F	99	100	102
SOLUTION CONCENTRATION				
27	FROM GENERATOR %	61.8	62.6	63.3
28	FROM ABSORBER %	57.7	58.5	59.2
29	TO SPRAYS %	59.8	60.6	61.3
CHECKS				
30	HEAT BALANCE %	1.0	0.1	0.39
31	RELATIVE CIRCULATION $\frac{LB}{LB}$	15.1	15.25	15.4
RESULTS AND ADDITIONAL INFORMATION				
32	LOAD TONS	414	414	414
33	ECONOMY (CORR.) / TON - HR.	17.35	17.85	18.38

LD04771

FIG. 22 - OPERATING DATA SHEET

## SECTION 9 – PTX CHART

### READING THE PTX CHART

(See Fig. 23)

The PTX chart (Pressure, Temperature, and Concentration chart) is an invaluable tool when it comes to absorption cooling. It can be used for almost every kind of troubleshooting situation, plotting solution cycles through each heat exchanger, and determining if air is within the system.

However, for this exercise the PTX chart will be explained only for determining the concentration of solution samples.

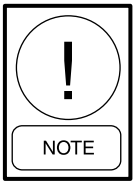

***Taking solution samples must only be done by a trained and qualified YORK Field Service Representative.***

### Determining the Solution Concentration:

The PTX chart shows Pressure in mm Hg. Absolute (horizontal lines), Temperature in Degrees Fahrenheit (vertical lines), and Solution Concentration in percentages (diagonal lines). The PTX chart in Fig. 23 is for single stage absorption machines because the temperature stops at 230°F. This is the highest expected temperature in the complete single stage absorption cycle (in the generator). On the two stage absorption cycle, the highest expected temperature will be around 330°F. Notice the "Crystallization Area" is the right half of the chart and is to the right of the thickest diagonal line.

For reading the PTX chart, two pieces of information are required to obtain the third. The temperature is the easiest to obtain and the pressure can be obtained via the unit gauges. Use caution when using the unit mounted mercury manometer for checking the internal unit pressure – DO NOT under any circumstances let air into the unit when checking the pressure. See the Purging section of this manual for the correct method to check the unit pressures. Looking at the PTX chart, follow the vertical temperature line and the horizontal pressure line to where the two intersect. The closest diagonal line to this intersection would be the correct solution concentration.

### CRYSTALLIZATION

All absorption chillers that use lithium bromide and water as the solution/refrigerant pair are subject to the perils of crystallization. This is due to the fact that some areas of the unit operate with solution liquid concentration levels that are only possible at higher than the normal ambient temperature surrounding the unit. For example, the solution concentration in the generator of a single stage absorption unit is typically 64.3% lithium bromide by weight. Referring to Figure 23, 64.3% solution will begin to crystallize at 100°F (37.8°C). Since the solution temperature in the generator normally is higher than 200°F (93.3°C) at most load conditions, no crystallization will occur as long as the higher solution temperatures are maintained. Special measures do have to be taken before the unit is shut down so that the solution is sufficiently diluted in all areas of the unit to prevent crystallization during the off cycle, since the solution temperature will eventually equal the surrounding ambient temperature. All units employ some sort of dilution cycle, which fulfills this requirement. As long as the unit is allowed to dilute itself during an orderly shutdown sequence, the unit should be able to sit idle at fairly low plant room ambient temperatures for extended periods of time without any threat of crystallization. Typically, after a dilution cycle, the average solution concentration within the chiller will be below 45% lithium bromide by weight. Although the crystallization line on Figure 23 does not extend that far, it can be seen that the solution at 45% concentration will have no tendency to crystallize at normal ambient temperatures.

### Why Does Crystallization Occur?

Probably the most predominant reason for crystallization is due to fairly long duration power failures. If a chiller is running at full load and power is interrupted for a sufficient length of time, the concentrated solution in the high side of the unit will eventually cool down. Since no dilution cycle was performed, the solution concentration in some areas of the unit may still be relatively high. If the temperature of this concentrated solution is allowed to fall low enough, the solution will reach its crystallization point. Plant room temperature, insulation quality and the solution concentration all play a part in the determination of how long it will take before the unit will crystallize.

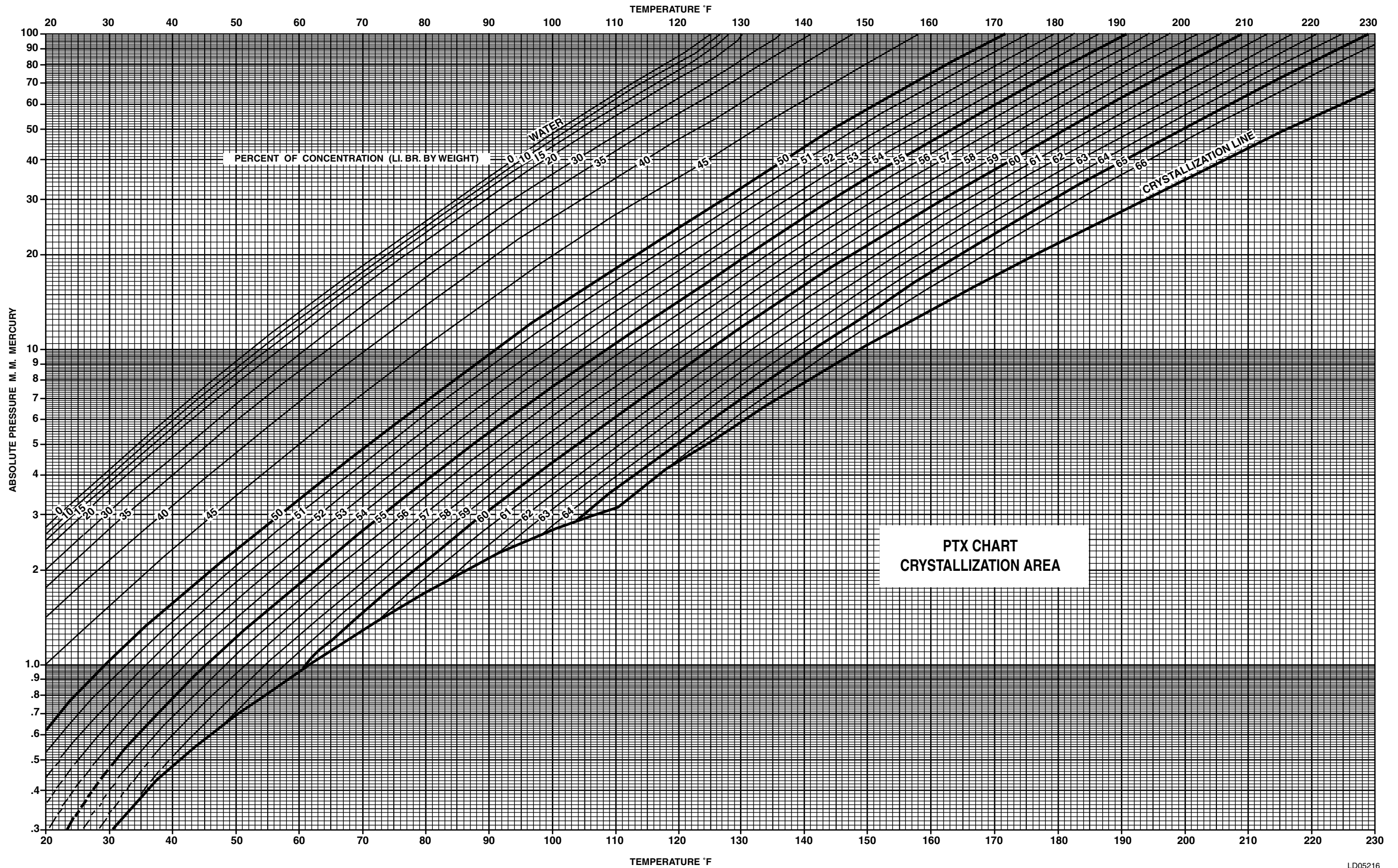

FIG. 23 – PTX CHART

Power failures result in the unit pumps stopping completely. Without the pumps inducing flow through the various sections of the unit, concentrated solution becomes trapped in the generator section and the solution-to-solution heat exchanger. If this concentrated solution is allowed to cool down to a low enough temperature, it may turn to a slushy liquid and eventually to a solid substance.

The potential for a YORK IsoFlow™ Chiller to crystallize during a power interruption is directly related to the following:

1. The concentration of the solution in the solution heat exchanger is very important. The higher the concentration at the time of power failure, the more likely the unit is to crystallize.
  - a. The higher the load, the higher the concentration.
  - b. A unit with dirty tubes or non-condensables will be more susceptible due to higher concentrations in the solution heat exchanger.
  - c. Overfiring the unit will tend to over concentrate the strong solution and make it more susceptible for crystallization.
2. The ambient temperature of the machine room and the amount of thermal insulation on the solution-to-solution heat exchanger will also determine the likelihood of crystallization. Improper or inadequate thermal insulation on the hot sections of the unit will allow heat loss to progress rapidly and therefore shorten the amount of time before the concentrated solution cools down to its crystallization temperature.
 

Outside air dampers that remain open during a power failure may allow the plant room to cool down quickly, which will hasten crystallization.
3. The duration of the power interruption is very important. Although it is very difficult to quantify the acceptable time before crystallization occurs, it is doubtful that harmful crystallization will occur if the power interruption is less than fifteen minutes. Thirty minute or longer power interruptions have been experienced during full load operation of some machines with no problems.

Although a more rare occurrence, units can also crystallize during operation. Two of the chief causes of crystallization during operation are non-condensables in the absorber and rapidly fluctuating tower water temperatures.

### Non-condensables in the Absorber

Non-condensables in the absorber result in less refrigerant being absorbed by the solution. The solution never gets as diluted as it should. It leaves the absorber and is heated in the generator. If the unit's heat input is at or near full load, the leaving solution concentration may exceed the level at which it can remain liquid when passing through the solution-to-solution heat exchanger. For example, the normal concentration of solution leaving the absorber at full load is between 58% and 59.3%. If there are non-condensables present in the absorber, the solution concentration may exceed 61%. Since the unit is attempting to operate at full load, the firing rate will be sufficient to raise the solution concentration in the generator by at least the same amount as when the absorber solution was normal, which was approximately 5%. Raising the solution concentration by 5% would result in 66% solution leaving the generator. Referring to the PTX chart in Figure 23, it can be seen that the crystallization temperature for 66% solution is approximately 120°F (49°C). Since the generator temperature is higher than 120°F (49°C), the solution will be okay while it is still in the generator. The problem occurs when this over concentrated solution passes through the solution-to-solution heat exchanger on its way back to the absorber sprays. Since this solution concentration remains constant as it passes through the solution-to-solution heat exchanger, if it is cooled below 120°F (49°C) at any point in the route, crystallization will begin. The cool solution leaving the absorber is the solution-to-solution heat exchanger's medium that cools the concentrated solution leaving the generator as it passes on the shell side of the solution-to-solution heat exchanger. This relatively cool solution's temperature is the determining factor of whether crystallization occurs. Tower water inlet temperature will greatly affect the leaving solution temperature of the absorber. If the tower water temperature is lower than design or is allowed to fluctuate in a downward trend fairly rapidly, the potential exists to over cool the concentrated solution in the solution-to-solution heat exchanger. Crystallization will then result.

To further compound this type of situation, if the absorber is not performing well due to the presence of non-condensables, the amount of solution flowing to the generator will be less than normal since there is less refrigerant in it. Since the unit is attempting

to make design capacity, the firing rate will be sufficient to raise the solution concentration higher than the design 5%. This will result in even higher solution concentrations leaving the generator. The temperature of the solution leaving the absorber will also be lower than normal due to the amount of subcooling that will be present as a result of the lack of mass transfer taking place. This will result in a greater potential for over cooling the concentrated solution in the solution-to-solution heat exchanger.

### Fluctuating Tower Water Temperature

Rapidly fluctuating tower water temperature can also cause crystallization. The reasons are essentially the same as described in the previous example. Rapidly falling tower water temperature will cause the leaving solution temperature from the absorber to drop quickly. This cool solution may over-cool the concentrated solution leaving the generator as it passes on the shell side of the solution-to-solution heat exchanger. This can happen at normal generator solution concentrations, although, of course, the problem would be compounded if there were already abnormally high solution concentrations in the generator.

### Features That Will Help Prevent Crystallization From Occurring

YORK IsoFlow™ chillers have several features that will help prevent crystallization from occurring. They are as follows:

1. The refrigerant charge is adjusted at full load, with no non-condensables present, so that refrigerant is just ready to spill over the evaporator pan to the absorber. Therefore, if the absorber ever begins to malfunction due to the presence of non-condensables or dirty tubes, the solution concentration will increase (less refrigerant present in solution). Consequently, the refrigerant quantity in the evaporator pan will increase and begin to spill over into the absorber solution, resulting in a concentration reduction.
2. **For units with Eprom version A.02F.00:** Whenever the unit is running, a feature called Strong Solution Temperature Control is used. The micro panel software continually monitors three different temperatures throughout the system as follows:

- a. Refrigerant temperature leaving the condenser - (RTLC) at RT9.
- b. Strong solution temperature at RT3.
- c. Leaving chilled water temperature - (LCWT) at RT1.

RT9 and RT3 have operating ranges in relationship to each other for normal unit conditions. If the strong solution temperature exceeds the allowable limit, steam or hot water control valve loading is inhibited and the RTLC/strong solution temperature algorithm is enabled to slowly pulse the valve closed, until the strong solution temperature is less than or equal to the limit. See YORK Form 155.16-O3 for details on this feature.

**If the unit is equipped with Eprom A.02F.01:** Low Entering Condenser Water Temp Load Limit replaces the Strong Solution Temp Control and the micro panel will also monitor the Entering Tower Water temperature through RT5. After a 30 minute bypass at unit start, whenever the entering condenser water temperature is less than 74°F (23.2°C), the maximum allowed steam/hot water valve position is limited. **Units equipped with Eprom A.02F.02 and later:** in addition to requiring the entering condenser water temperature to be less than 74°F (23.2°C), the strong solution temperature must be equal to or greater than the Low Entering Condenser Water Temperature (ECDWT) Solution temp override setpoint to perform the control valve limiting to approximately 60%. For more details on these features, see YORK Form 155.16-O3.

3. The third type of crystallization prevention is through the Automatic Decrystallization Cycle (ADC). Essentially, when crystallization starts to occur, a blockage usually forms in the strong solution side of the solution-to-solution heat exchanger. This blockage inhibits the solution from flowing through the solution-to-solution heat exchanger and the solution starts to back-up into the generator. Solution starts to fill the generator outlet box and begins exiting through the ADC line. RT2, attached to the side of the ADC line senses the temperature rise in this line due to the high temperature solution flowing through it. At 160°F (71.1°C) the micro panel will energize 2SOL (Stabilizer or decrystallize solenoid valve) to allow refrigerant to flow from the discharge of the refrigerant pump into the solution-to-solution heat exchanger, thus diluting the solution.

## Measures to Prevent Crystallization

Good practices to help prevent crystallization should be employed. These include:

1. Insulating the solution-to-solution heat exchanger, generator solution outlet box and all interconnecting piping.
2. Tower water (absorber cooling water) must be controlled to prevent rapid fluctuations in temperature.
3. Keep absorber, condenser and evaporator tubes clean.
4. Do not allow non-condensables to accumulate in the unit. Proper purging techniques and solution chemistry control will greatly reduce the likelihood of crystallization.
5. Be sure the refrigerant charge is adjusted so that refrigerant spill will occur if solution concentrations exceed the norm. Refrigerant may need to be adjusted after several years of operation due to the amount of refrigerant vapor removed during purging.

## PRESSURE DROP CURVES

Figure 24 shows the pressure drops for the chilled water, condenser water, and the hot water in relationship to the rate of flow in GPM. The absorber/condenser includes 1 - 2 PSI pressure drop through the cross-over line. For construction of the cross-over line, see YORK Form 155.16-N3. **The data shown are for pressure taps on the water boxes near the inlet and outlet nozzles.** If pressure gauges are used to determine pressure drop, they should be calibrated so that maximum efficiency is obtained. Also, a correction for static head difference must be made if the

gauges are not located at the same elevation or level. The conversion from PSI to ft. of water is 2.31 ft. for 1 PSI.

## REFRIGERANT CONCENTRATION

Operation at low loads and low condensing water temperatures will cause solution to be brought over to the refrigerant circuit to sustain operation and avoid extensive cavitation of the refrigerant pump. At such times that a system analysis is conducted at high load and high condensing water temperature, the solution in the refrigerant circuit would have been appreciably diluted, by virtue of the full evaporator pan that develops. With the effect of blowdown and possibly some spillover, the refrigerant concentration level is probably very near 1.00 S.G. Considering the intent of an analysis, it may be desirable to route some of the refrigerant back to the absorber via the refrigerant valve (2 SOL) to establish a still cleaner refrigerant. For refrigerant blowdown, see "Control Components External To The Control Center" for this operation.



***During refrigerant blowdown, stop the refrigerant pump immediately on pump cavitation noise or from indications on a pressure gauge on pump discharge (fluctuating wildly).***

At minimum loads (10%) and minimum condensing water temperature, the concentration in this circuit could reach 35 to 40% by weight lithium bromide. As the load increases and the pan fills, this concentration will diminish and eventually be very slight or non-existent.

# PRESSURE DROP CURVES

**MODEL YIA - 1A1**

**MODEL YIA - 1A2**

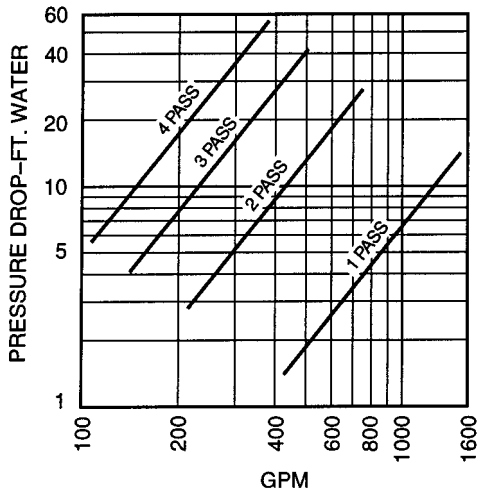

LD01506

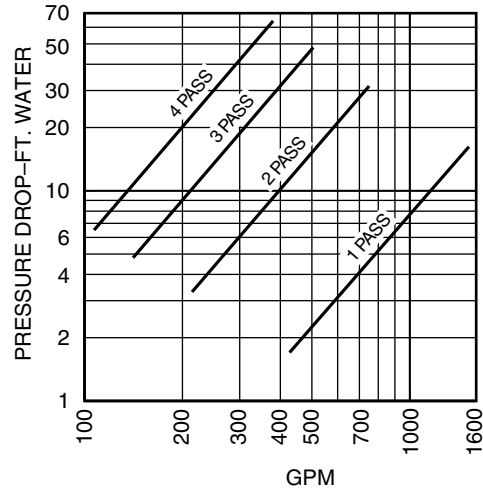

LD01509

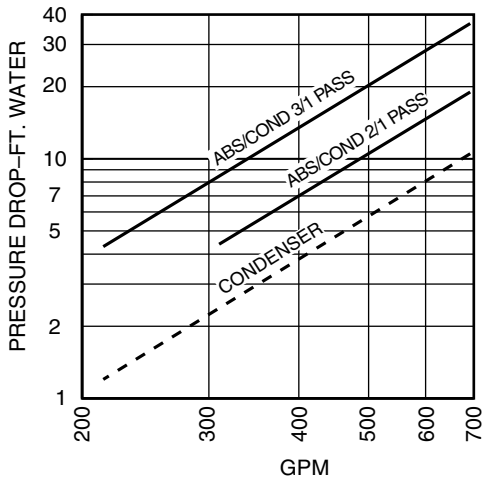

LD01508

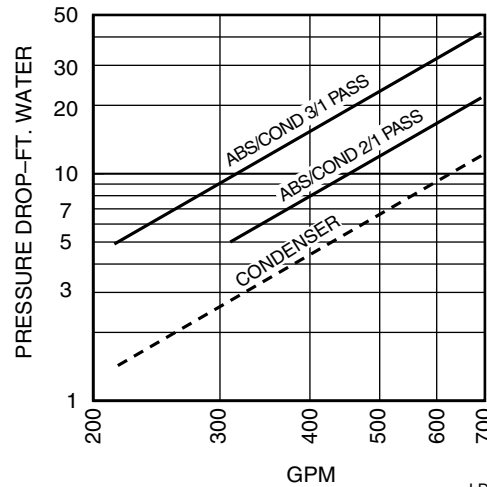

LD01511

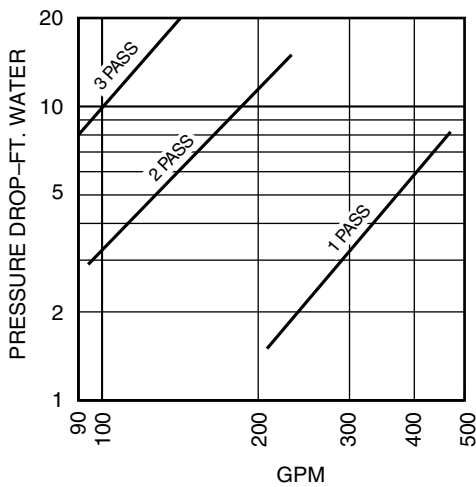

LD01507

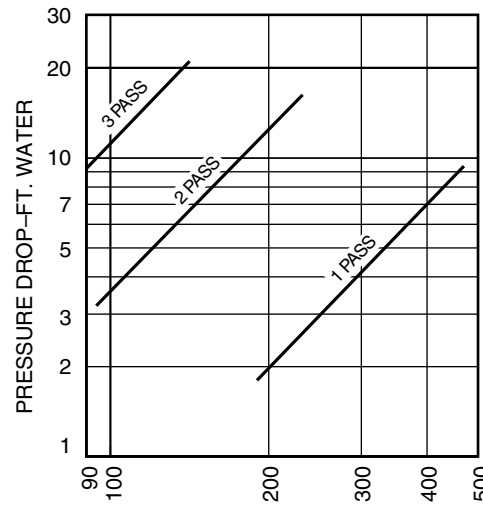

LD01510

\* See Notes on page 56.

**FIG. 24 - PRESSURE DROP CURVES**

**MODEL YIA – 2A3**

**MODEL YIA – 2A4**

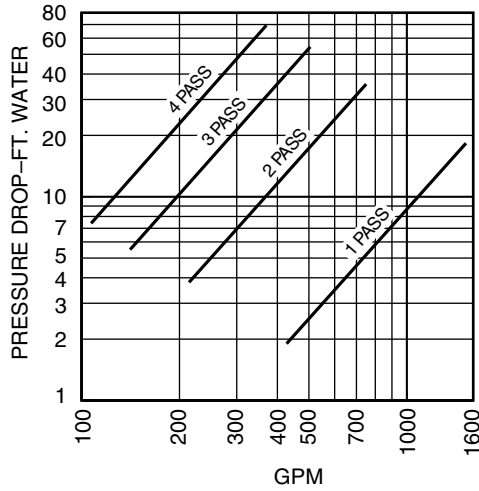

LD01512

**CHILLED WATER**

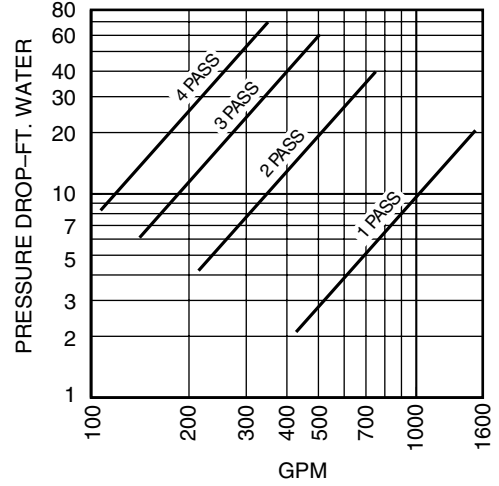

LD01515

**CHILLED WATER**

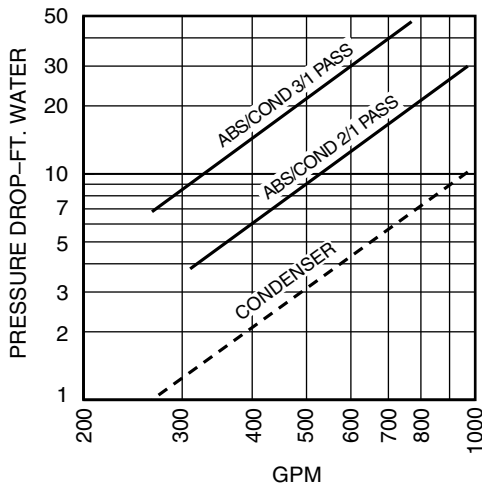

LD01514

**TOWER WATER \***

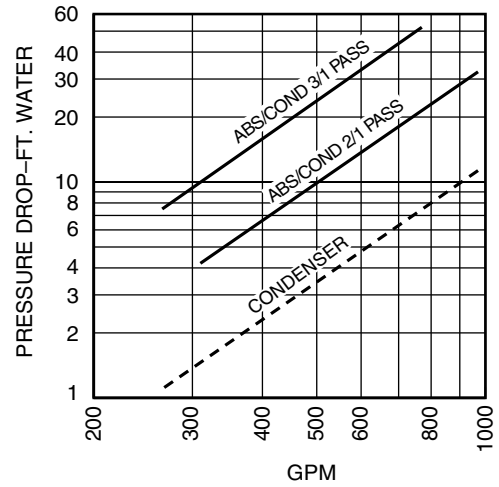

LD01517

**TOWER WATER \***

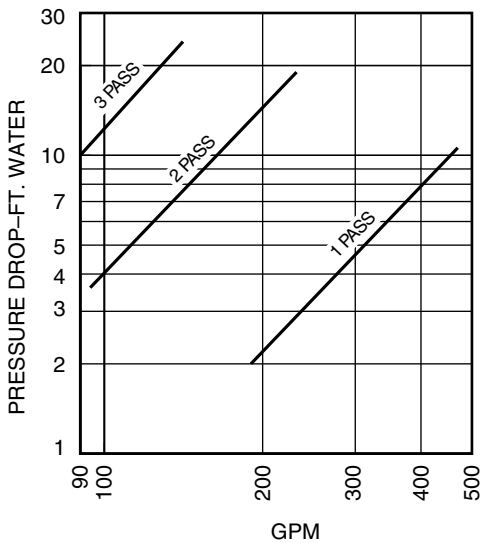

LD01513

**HOT WATER**

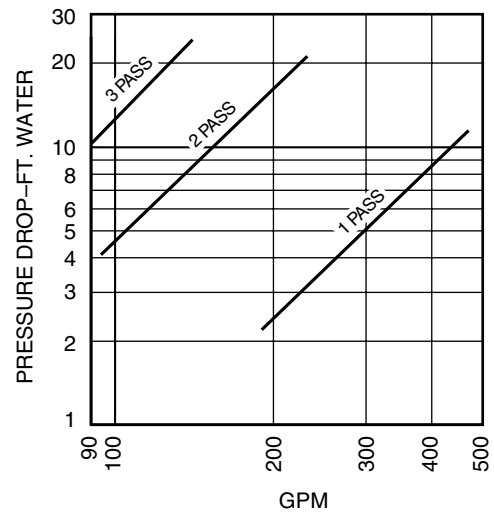

LD01516

**HOT WATER**

**FIG. 24 – PRESSURE DROP CURVES (CONTINUED)**

\* See Notes on page 56.

**MODEL YIA – 2B1**

**MODEL YIA – 3B2**

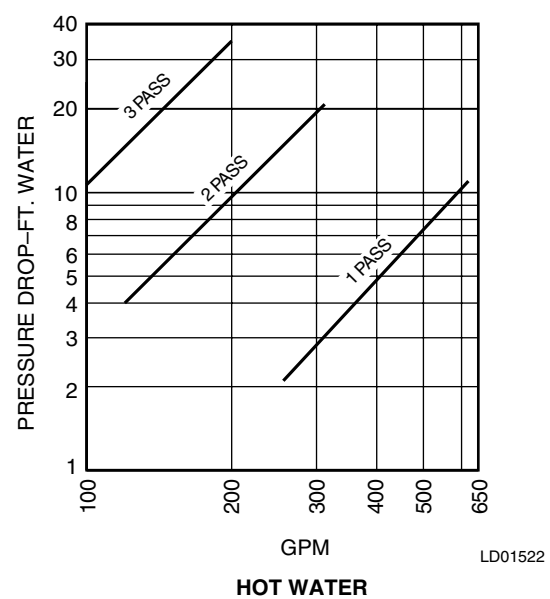
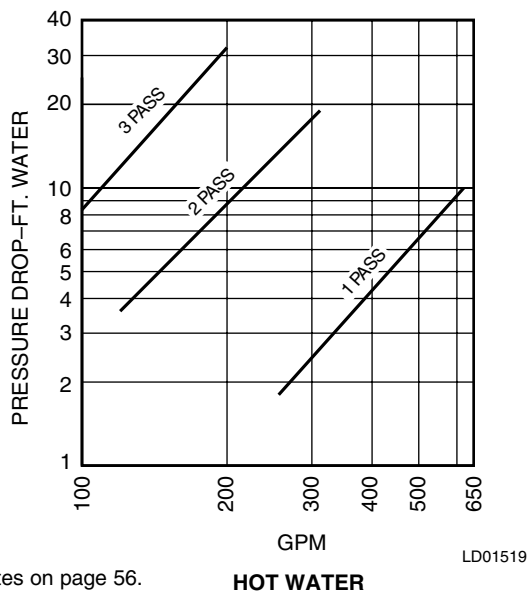
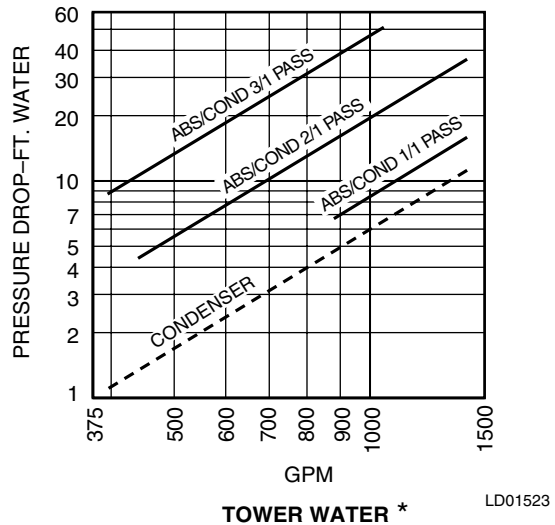
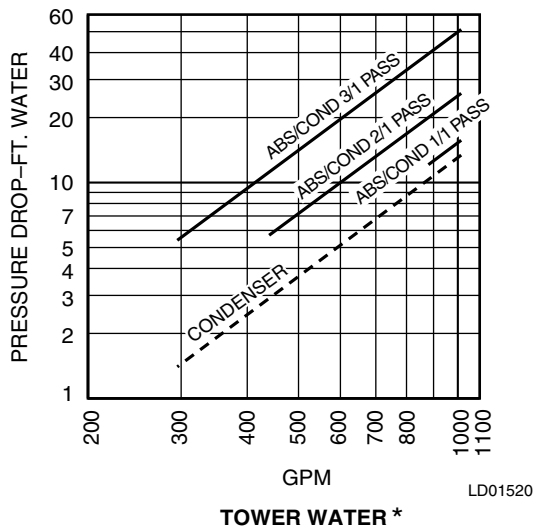
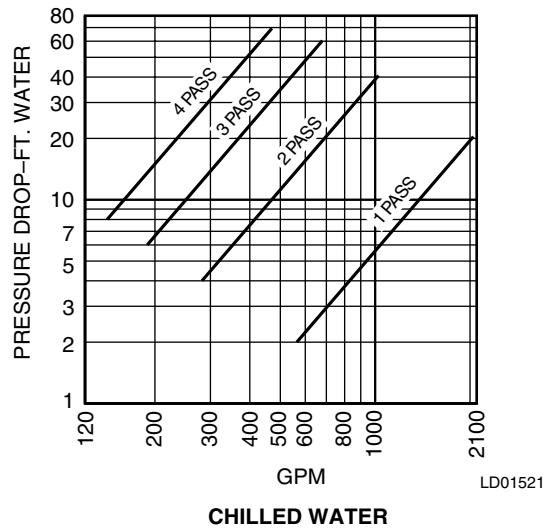
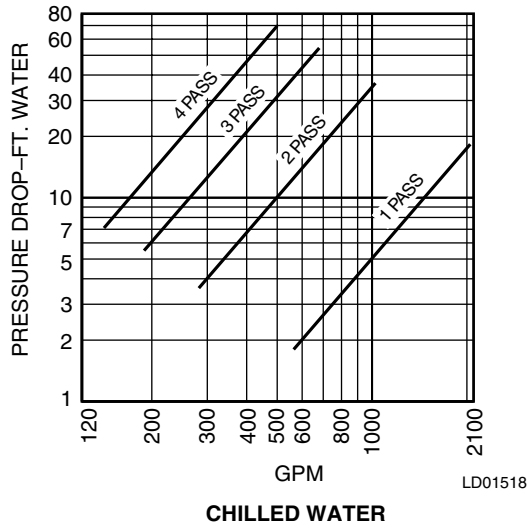

\* See Notes on page 56.

**FIG. 24 – PRESSURE DROP CURVES (CONTINUED)**

**MODEL YIA - 3B3**

**MODEL YIA - 4B4**

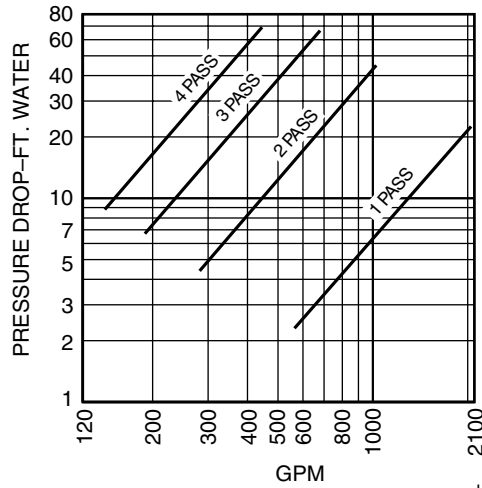

LD01524

**CHILLED WATER**

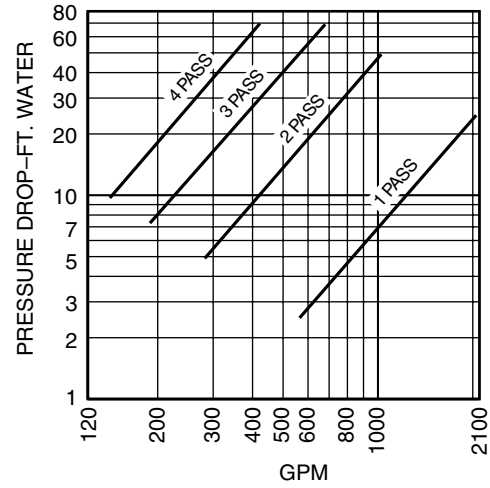

LD01527

**CHILLED WATER**

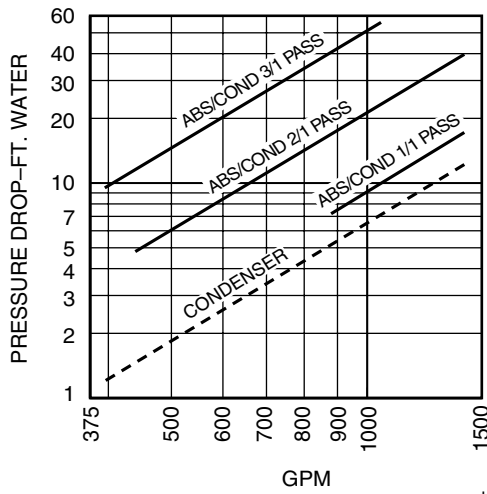

LD01526

**TOWER WATER \***

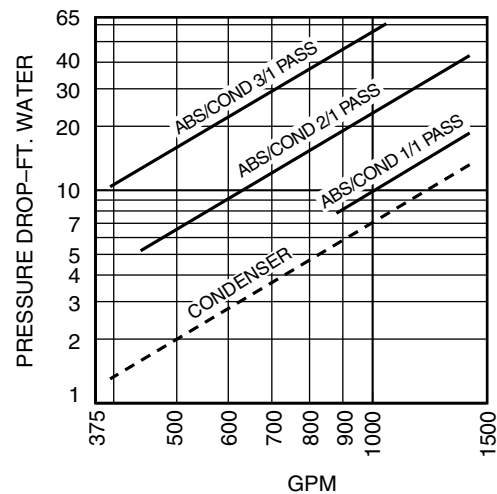

LD01529

**TOWER WATER \***

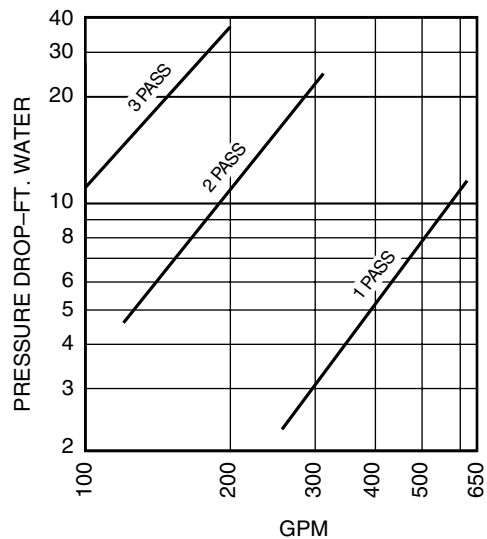

LD01525

**HOT WATER**

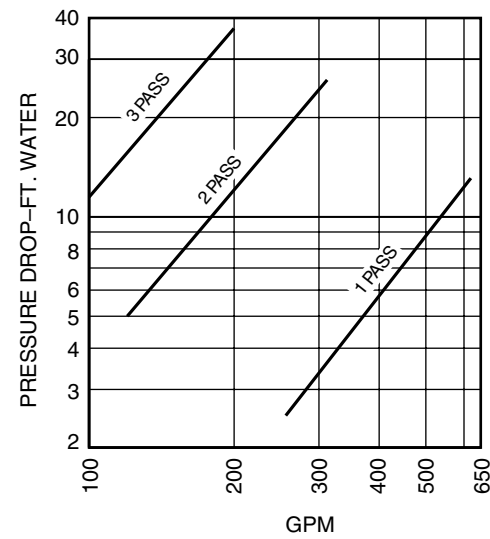

LD01528

**HOT WATER**

\* See Notes on page 56.

**FIG. 24 - PRESSURE DROP CURVES (CONTINUED)**

**MODEL YIA - 4C1**

**MODEL YIA - 5C2**

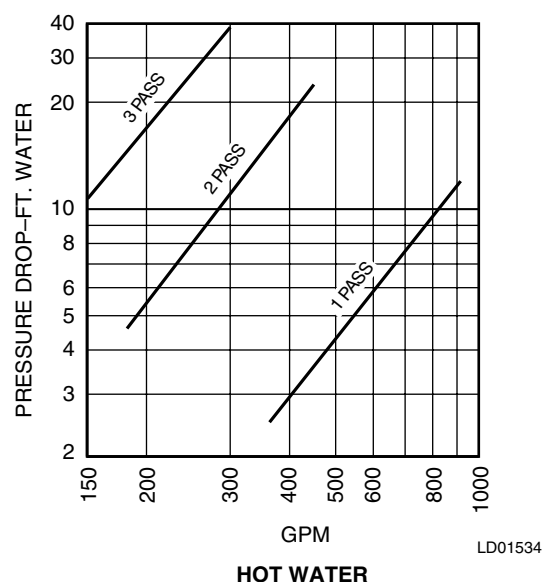
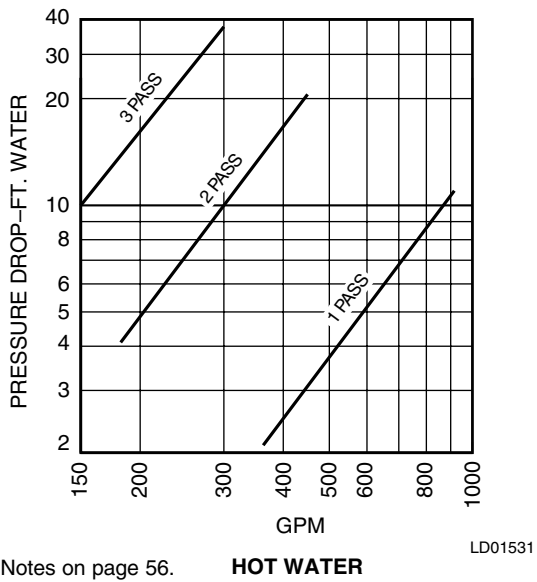
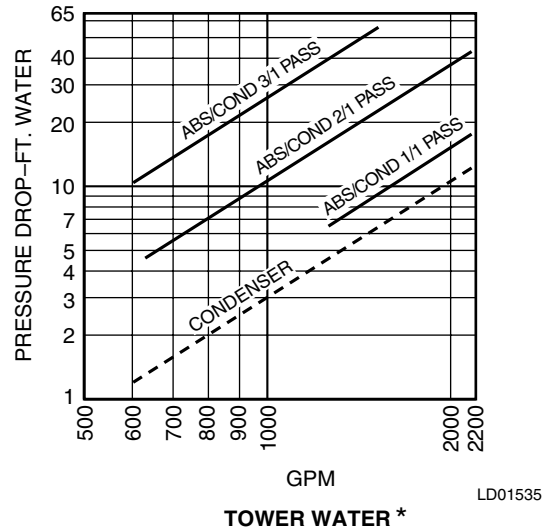
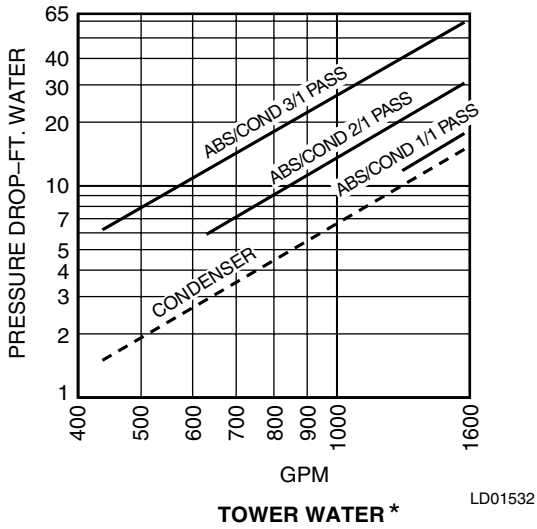
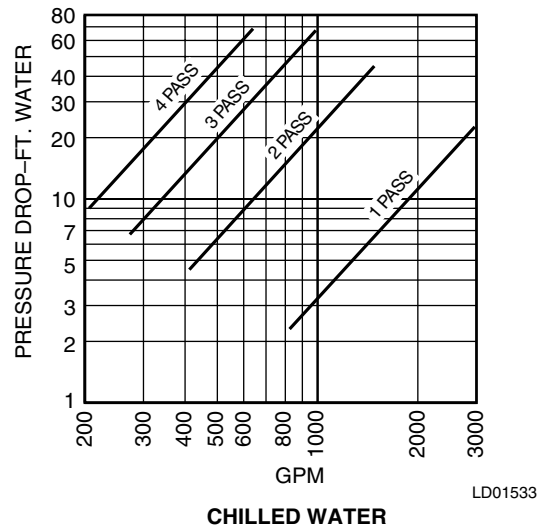
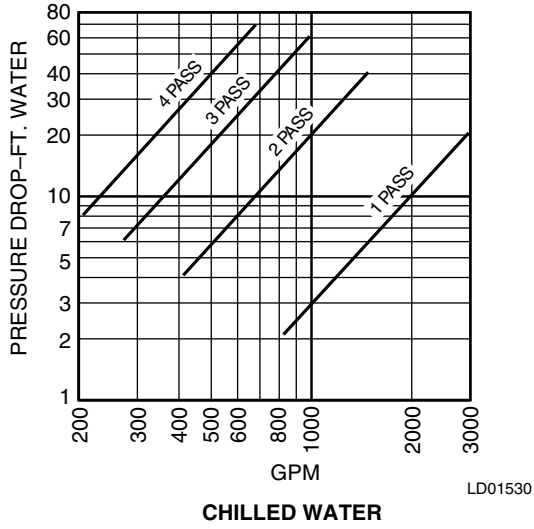

\* See Notes on page 56.

**FIG. 24 - PRESSURE DROP CURVES (CONTINUED)**

**MODEL YIA - 5C3**

**MODEL YIA - 6C4**

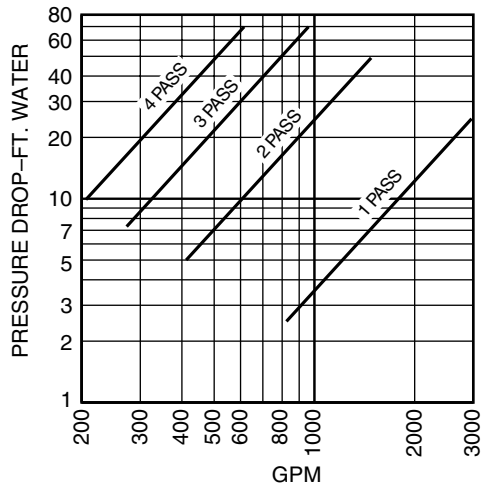

**CHILLED WATER**

LD01536

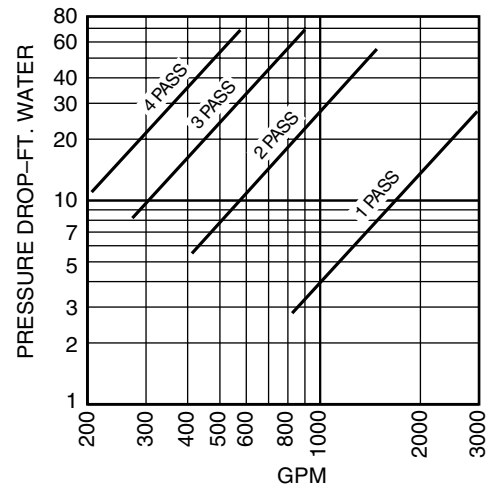

**CHILLED WATER**

LD01539

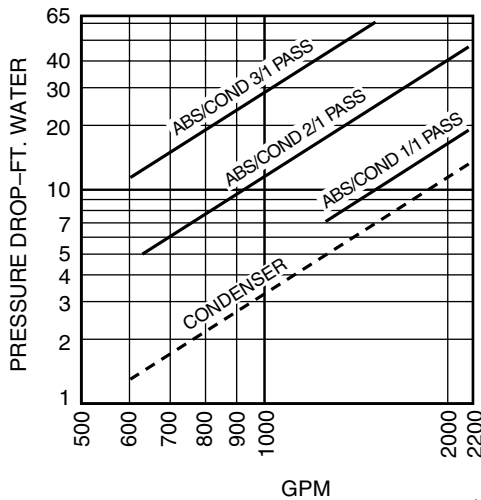

**TOWER WATER \***

LD01538

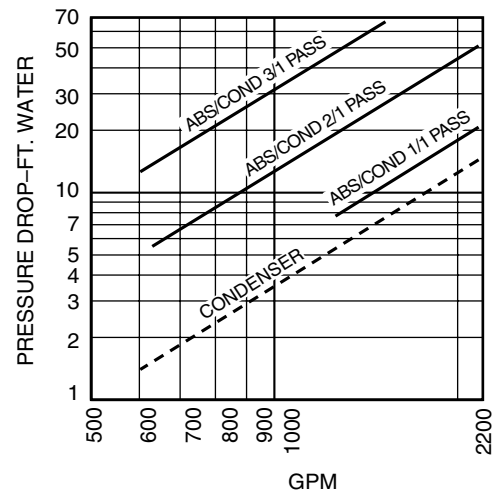

**TOWER WATER \***

LD01541

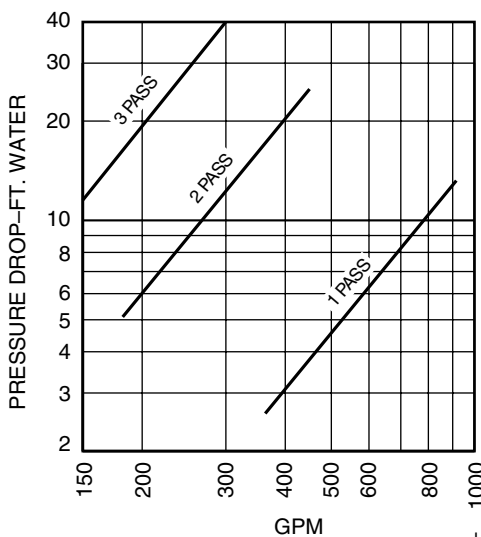

**HOT WATER**

LD01537

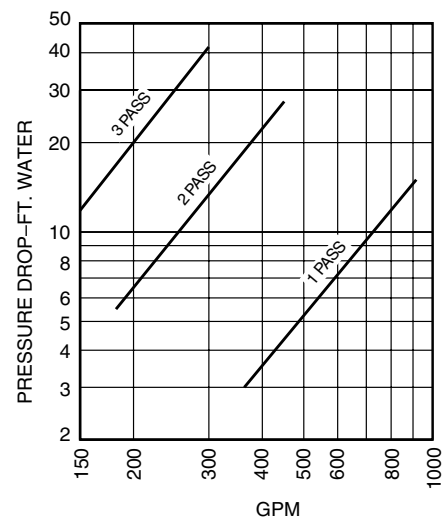

**HOT WATER**

LD01540

\* See Notes on page 56.

**FIG. 24 - PRESSURE DROP CURVES (CONTINUED)**

**MODEL YIA - 7D1**

**MODEL YIA - 7D2**

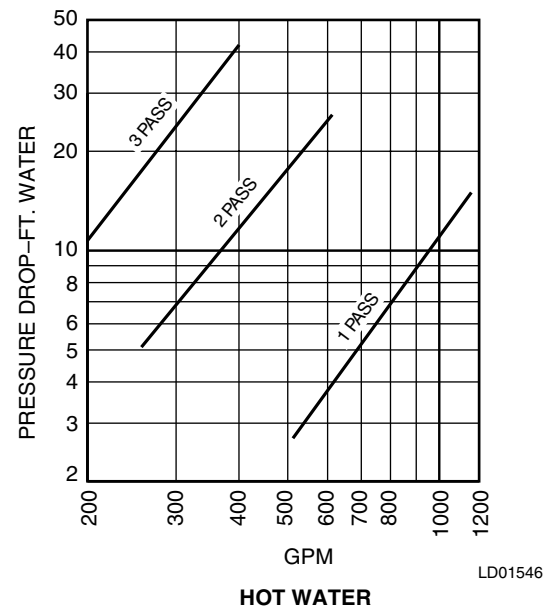
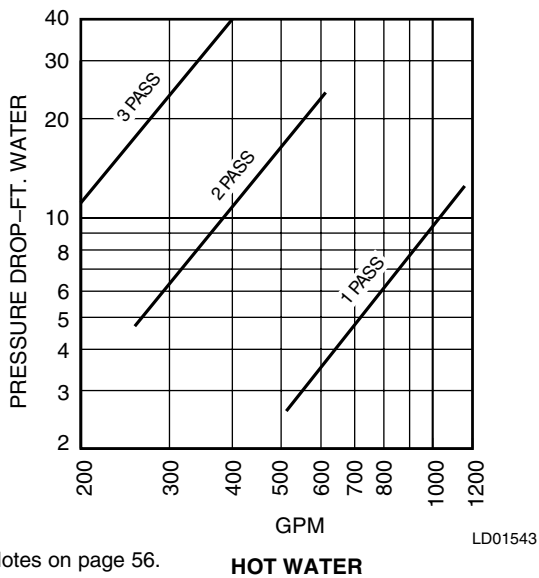
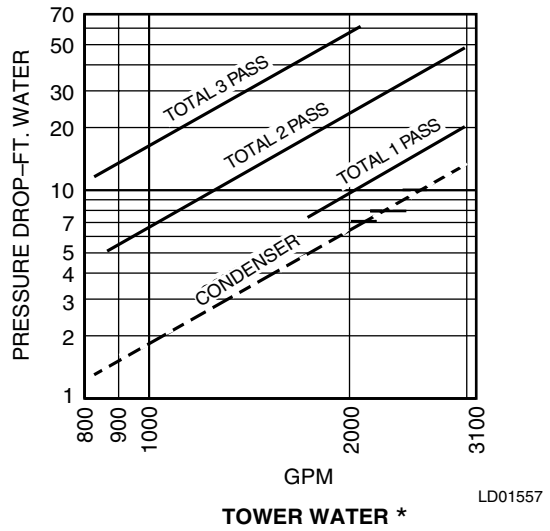
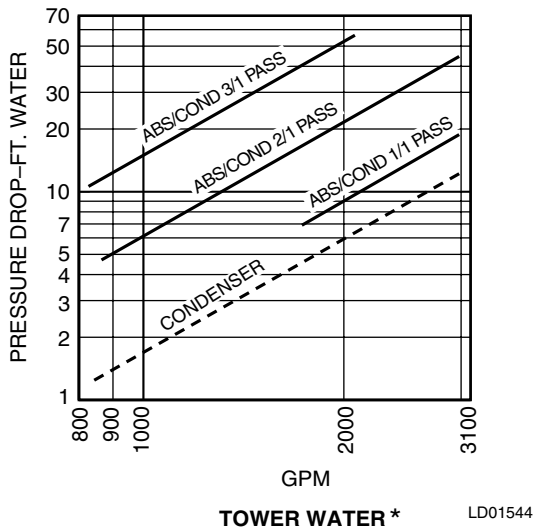
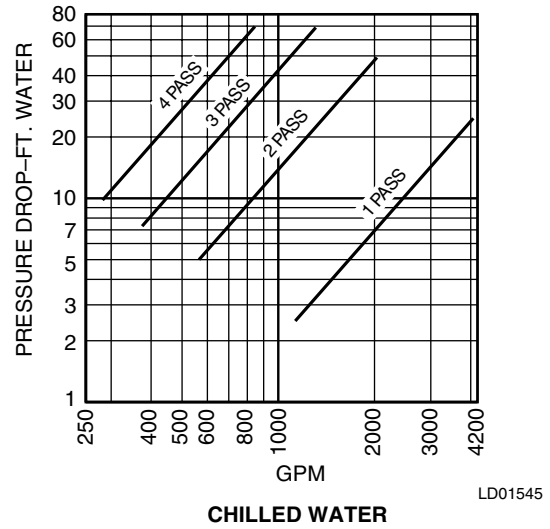
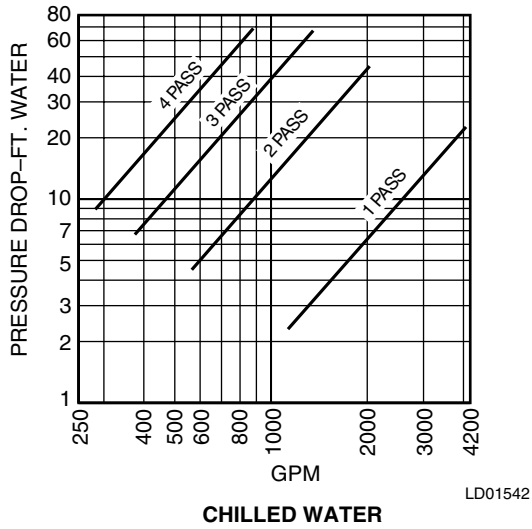

\* See Notes on page 56.

**FIG. 24 - PRESSURE DROP CURVES (CONTINUED)**

**MODEL YIA – 8D3**

**MODEL YIA – 8E1**

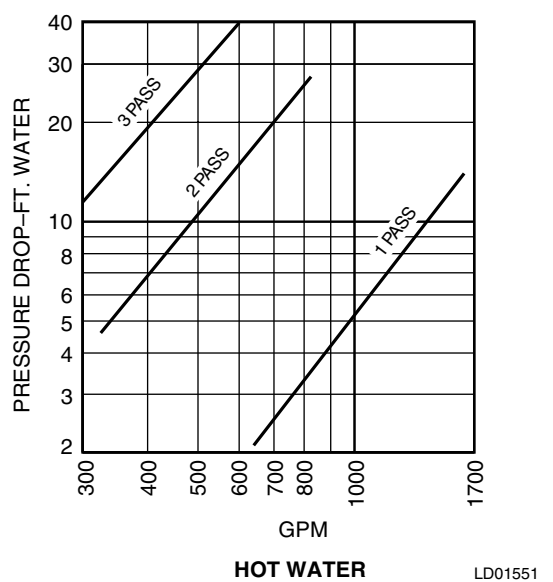
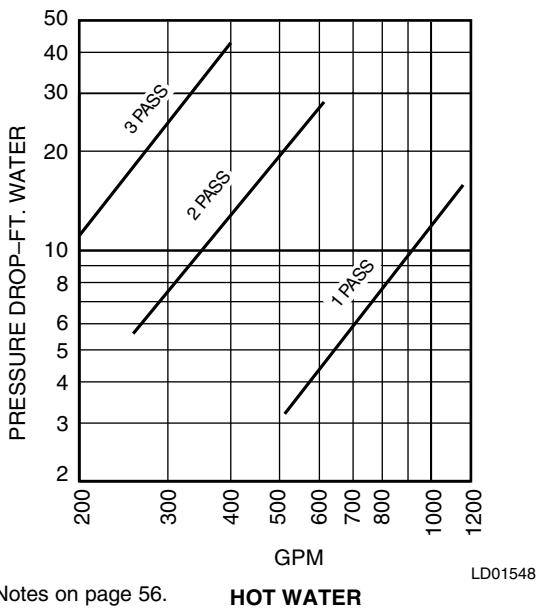
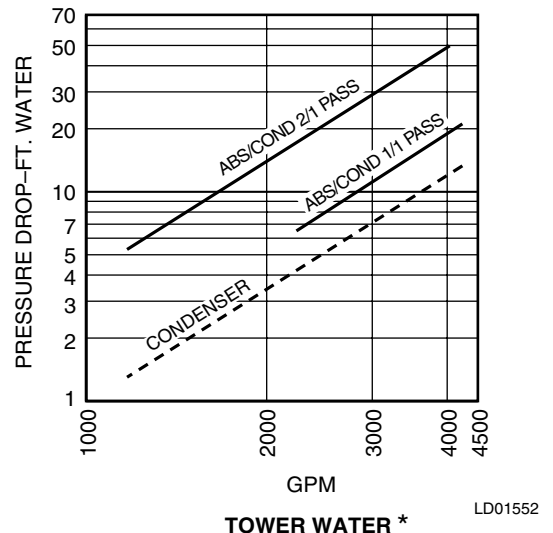
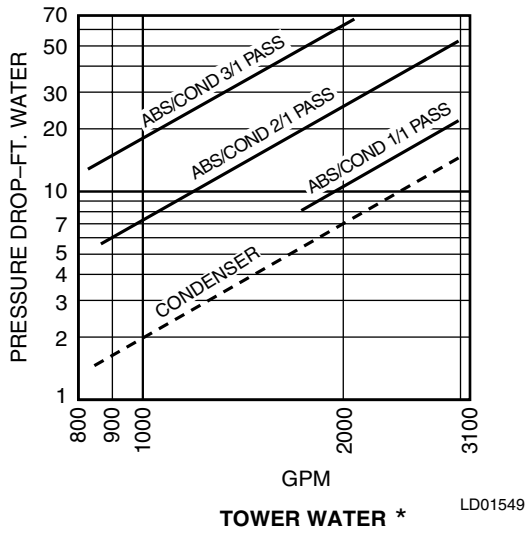
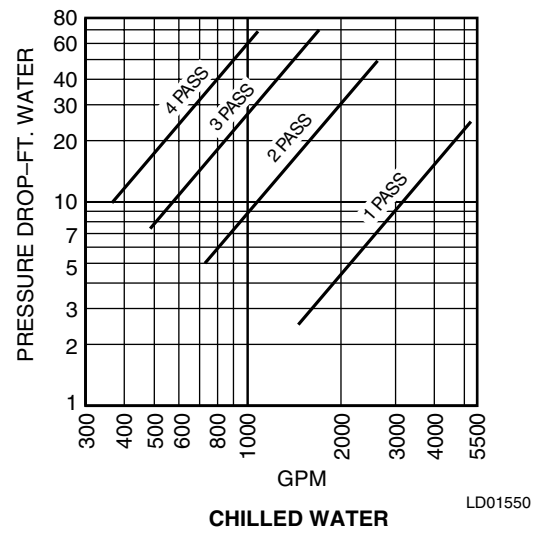
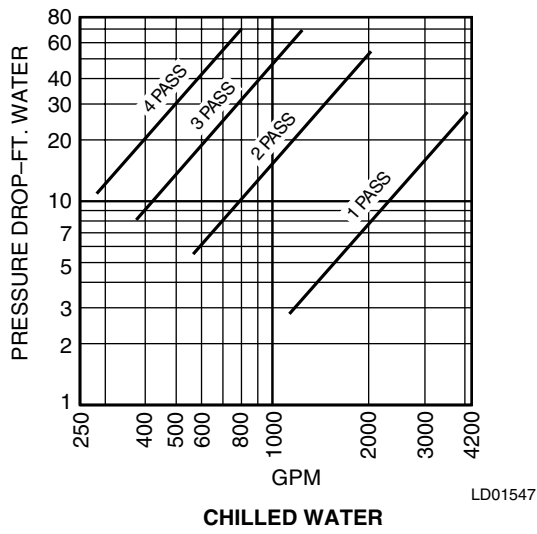

\* See Notes on page 56.

**FIG. 24 – PRESSURE DROP CURVES (CONTINUED)**

**MODEL YIA - 9E2**

**MODEL YIA - 10E3**

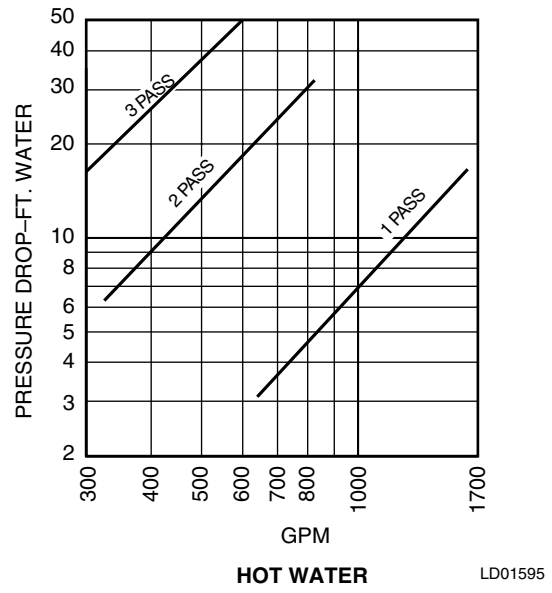
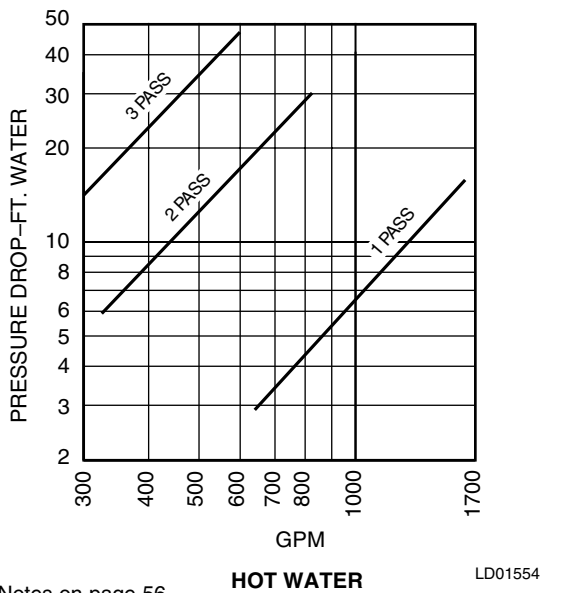
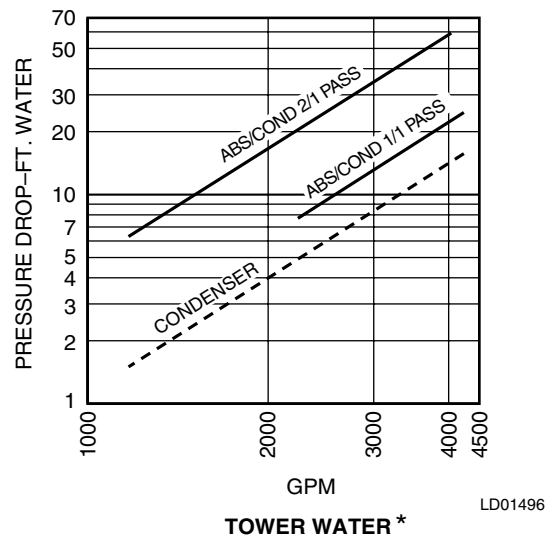
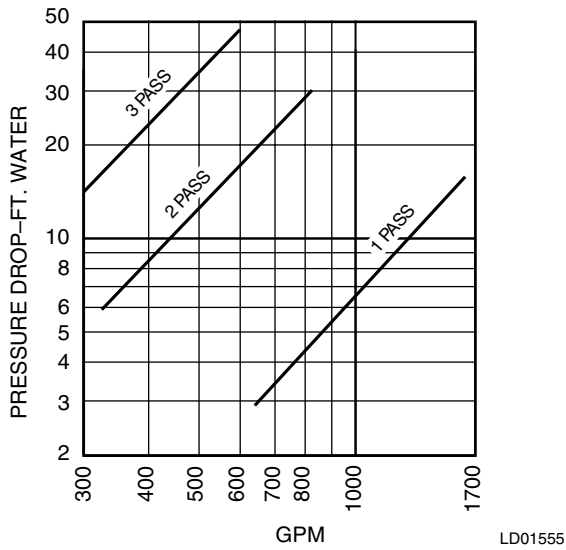
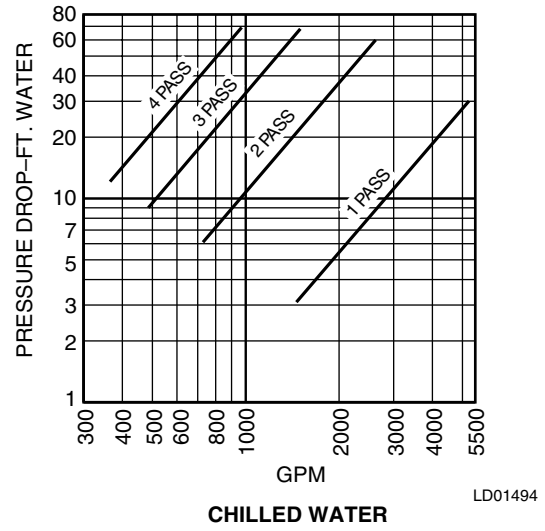
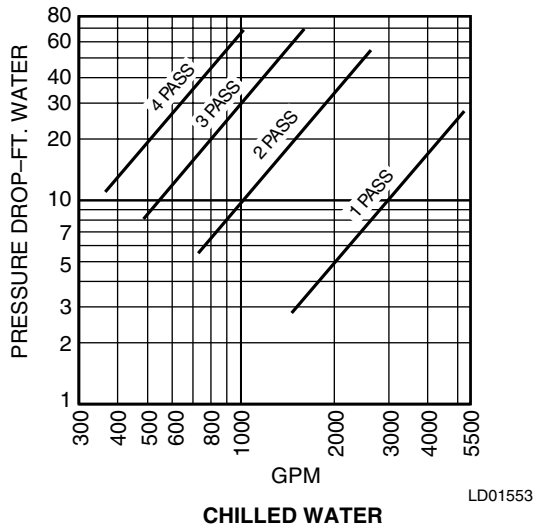

\* See Notes on page 56.

**FIG. 24 - PRESSURE DROP CURVES (CONTINUED)**

**MODEL YIA - 12F1**

**MODEL YIA - 13F2**

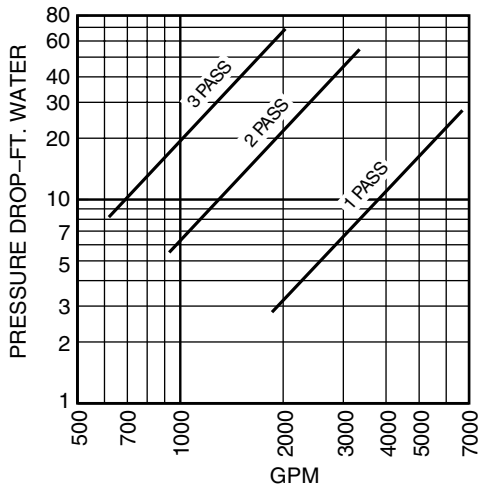

**CHILLED WATER**

LD01497

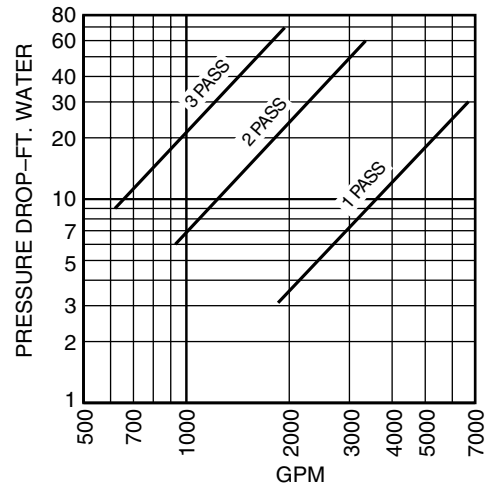

**CHILLED WATER**

LD01500

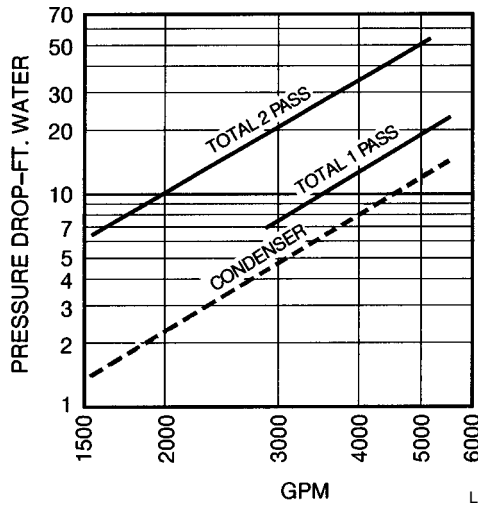

**TOWER WATER \***

LD01499

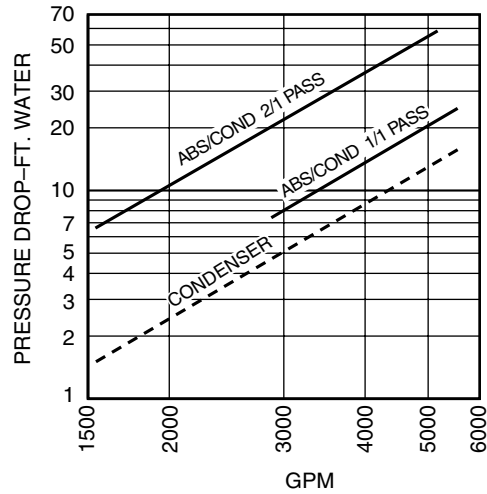

**TOWER WATER \***

LD01502

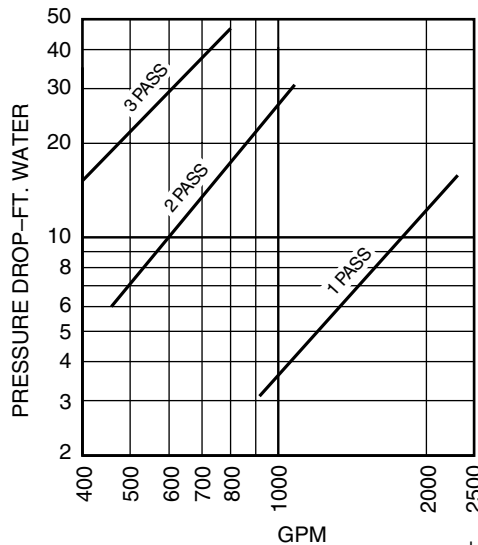

**HOT WATER**

LD01498

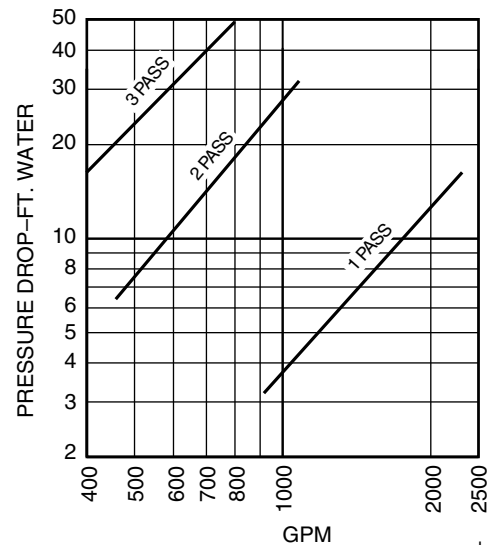

**HOT WATER**

LD01501

\* See Notes on page 56.

**FIG. 24 - PRESSURE DROP CURVES (CONTINUED)**

**MODEL YIA – 14F3**

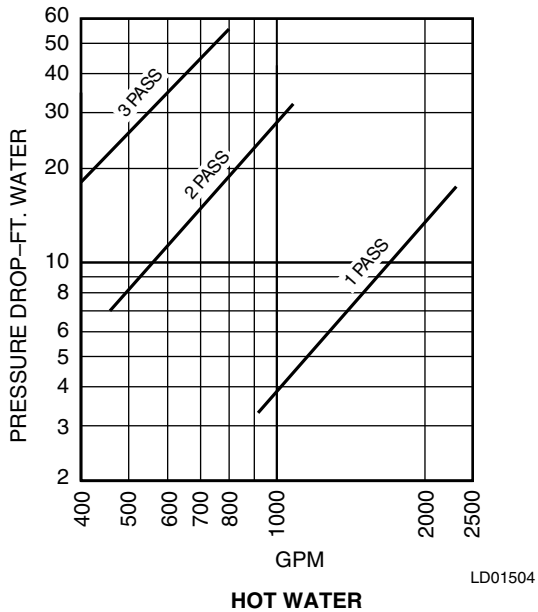
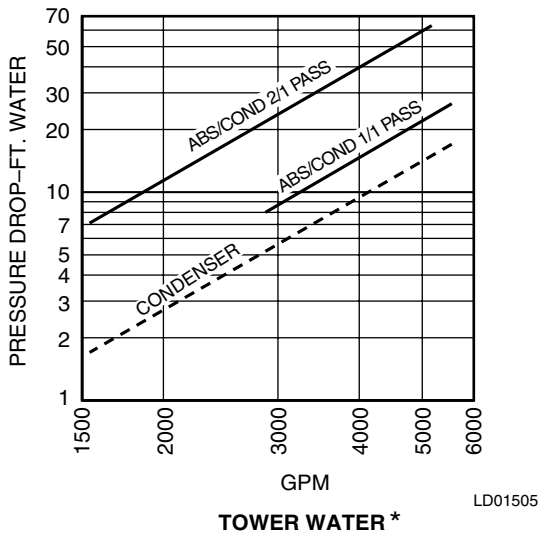
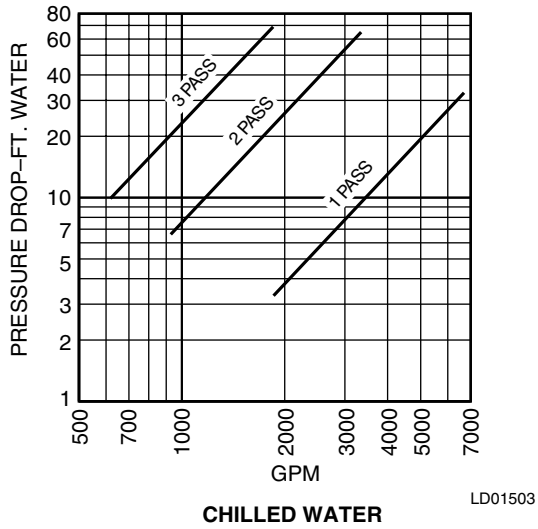

\* Pressure drop curves include 1 psi pressure drop for cross-over line.

\* Pressure drop curve for the condenser water circuit only is shown as a dotted line. For total tower water pressure drop through the chiller use the appropriate solid line. For example, a chiller with a 2-Pass absorber and a 1-Pass condenser, use the "ABS/COND 2/1 curve."

**FIG. 24 – PRESSURE DROP CURVES (CONTINUED)**

## SECTION 10 – PREVENTATIVE MAINTENANCE – TUBES

### CLEANING AND MAINTAINING THE TUBES WITHIN THE SHELLS

#### Tubes

The necessity for tube cleaning will be indicated by a drop in capacity or other symptoms. The frequency of cleaning will vary as influenced by local water characteristics, atmosphere contamination, operating conditions, etc.

In many major cities, reliable commercial organizations are now available which offer a specialized service of cleaning water sides of pressure vessels. These organizations will analyze the type of dirt or scale to be removed and then use the proper cleaning solution for the specific job.

Tube fouling is commonly due to deposits of two types as follows:

1. Dirt, rust or sludge which is carried from some other part of the system into the tubes. This material does not usually build up to coat the entire tube surface, but lies in the bottom of the tubes. When this accumulation of sludge is great enough, water flow through the tubes will be restricted and the heat transfer surface will be reduced. This type of tube fouling is easily visible and can be removed by a thorough brushing with a soft bristle bronze brush as outlined under "Brush Cleaning of Tubes".
2. Scale is a hard layer of mineral deposit which precipitates out of the water and forms a hard coating on the inside surfaces of the tubes. This coating is often invisible but always highly resistant to heat transfer.

The most common types of scale found within the tubes are calcium carbonate, calcium sulphate and silica, although other scales do form, depending upon local water conditions. Since scale is usually invisible when tubes are wet, it is better to blow the water out of the tubes and allow the tubes to

thoroughly dry before checking for scale. After the tubes have thoroughly dried, calcium scale will usually show up as a white coating inside the tube (silica scale may not show up at all); but the scale can usually be flaked off of the inside of the tube with a small knife.

The only positive method of identifying a scale is a chemical analysis, although an analysis of the water used in a specific system will indicate the type of scale which may be expected to form.

Although other good commercial cleaning agents are available for removing a specific scale, factory experience has been obtained chiefly with commercial inhibited hydrochloric (muriatic) acid, which has proven to be a good cleaning agent for most scales.

When it becomes necessary to clean condenser tubes, the absorber tubes should also be cleaned. If the chilled water system is kept clean during installation and is filled with clean water, it should not be necessary to clean the evaporator tubes, except if cooling water is used in an air washer. The lines to the purge drum and its coil must be acid cleaned when cooling circuit is cleaned.

#### BRUSH CLEANING OF TUBES

If tube fouling consists of dirt and sludge, it can usually be removed by means of the brushing process. Drain the water sides of the circuit to be cleaned (cooling water or chilled water), remove the heads and thoroughly clean each tube with a soft bristle bronze brush. **DO NOT USE A STEEL BRISTLE BRUSH.** A steel brush may damage the tubes.

Improved results can be obtained by admitting water into the tube during the cleaning process. This can be done by mounting the brush on a suitable length of 1/8" pipe with a few small holes at the brush end and connecting the other end by means of a hose to the water supply.

## TROUBLESHOOTING TABLE

SYMPTOM	POSSIBLE CAUSE	CORRECTIVE ACTION
<b>1. ABSORPTION UNIT WILL NOT START</b>	<ul style="list-style-type: none"> <li>A. Power supply and unit fuses.</li> <li>B. Flow switches open.</li> <li>C. Starter overloads open.</li> <li>D. Motor coolant float switch open.</li> </ul>	<p>Replace if necessary.</p> <p>Check chilled water and cooling tower pumps.</p> <p>Push reset buttons of both starters.</p> <p>Contact local district office for service.</p>
<b>2. UNIT CYCLING OR ERRATIC CHILLED WATER TEMPERATURE</b>	<ul style="list-style-type: none"> <li>A. Air in water piping causing varying water flow to the unit.</li> <li>B. Control valve not functioning properly (not closing).</li> <li>C. Low temperature thermostat not cutting out at correct temperature settings.</li> <li>D. Fluctuating steam pressure or hot water temperature.</li> <li>E. Cooling water temp. cycling improper tower fan setting.</li> </ul>	<p>Purge air from the water piping.</p> <p>Check actuator and linkage. Adjust if necessary.</p> <p>Check max. rate setting normal 1.0.</p> <p>Check cutout setting using 1/5°F thermometer setting 39°F. (If not working properly, contact local district office.)</p> <p>Correct supply source.</p> <p>Readjust settings.</p>
<b>3. UNIT NOT MAKING CAPACITY</b>	<ul style="list-style-type: none"> <li>A. Air in unit.                             <ul style="list-style-type: none"> <li>a. Improper purging</li> <li>b. Purge pump malfunctioning.</li> <li>c. Leak in unit.</li> </ul> </li> <li>B. Cooling (Tower) water GPM below design.</li> <li>C. Insufficient steam to the generator flange.</li> <li>D. Condensate backup into generator tubes.</li> <li>E. Tube fouling excessive.</li> <li>F. Crystallization                             <ul style="list-style-type: none"> <li>a. Air in unit</li> <li>b. Improper dilution cycle.</li> </ul> </li> <li>G. Cooling tower water temperature fluctuating rapidly.</li> <li>H. ADC circuit malfunction.</li> <li>I. Steam pressure too high.</li> </ul>	<p>See "Purge System Operation" section for proper procedure for purging.</p> <p>See "Purge Pump Maintenance" section for servicing information.</p> <p>Contact local district office for service.</p> <p>Set to correct quantity using design pressure drop for your unit.</p> <p>Check supply. Readjust steam valve and regulating valves, if necessary.</p> <p>Check steam trap float and/or valves.</p> <p>See "Preventive Maintenance" section for proper method of cleaning tubes.</p> <p>See "Purge System Operation" section for proper procedure for purging.</p> <p>Check float operation. Check dilution time operation. See that condenser water and chilled water pumps run until completion of dilution cycle.</p> <p>Readjust setting or replace controller and/or fan thermostats as necessary.</p> <p>Check sensor and 2SOL refrigerant solenoid for proper operation.</p> <p>Check setting of pressure reducing valve, if used. Adjust steam valve to reduce maximum opening..</p>
<b>4. PURGE PUMP INCAPABLE OF PULLING BELOW 1MM</b>	<ul style="list-style-type: none"> <li>A. Contaminated oil.</li> <li>B. Ballast valve cracked or scored.</li> <li>C. Malfunctioning pump.</li> </ul>	<p>Change oil as recommended.</p> <p>Repair with kit listed in "Renewal Parts" list.</p> <p>Repair or replace.</p>
<b>5. PURGE PUMP OIL LEAKAGE</b>	<ul style="list-style-type: none"> <li>A. Faulty shaft seal rubber.</li> </ul>	<p>Repair with kit in "Renewal Parts" manual.</p>

Component	Preventative Maintenance Operation	Maintenance Interval (Months unless otherwise indicated)										
		See Note Below	As Needed	Daily	Monthly	4	6	12	24	36	48	60
<b>Unit</b>	Solution Chemistry Analysis (Add inhibitors as needed)	(1), T										
	Record Operational Data (Data Form)			O								
	Leak Test Unit	(2)										
	Check Electrical Connections							T				
	Replace Sight Glasses or Glass Gaskets		T									
	Check For Proper Solution Levels, adjust as required							T				
	Check For Proper Refrigerant Levels, adjust as required							T				
	Check For proper Concentration of Octyl Alcohol		T									
Check Unit Level and/or Pitch (Steam Units)								T				
<b>Unit Safety Controls - Performance Test</b>	LRT - Low Refrigerant Temperature Cutout Switch							T				
	CHFLS - Chilled Water Flow Switch.							T				
	CWFLS - Condenser Water Flow Switch							T				
	HT1 - High Temperature Cutout Switch							T				
<b>Instrumentation</b>	Accuracy check of thermistors and transducers							T				
	Accuracy check of Condenser Pressure Gauge (if applicable)							T				
<b>Solution and Refrigerant Pumps</b>	Inspection (pump bearing and seal wear) Rebuild as required.	(3)									T	
	Inspection of pump contactors and overloads							T				
	Check operating amperage of pumps.			O				T				
	Check electrical connections to pumps							T				
	Check performance of pumps (pressures, etc.)							T				
	Check average skin temperatures of pumps							T				

PREVENTATIVE MAINTENANCE SCHEDULE

Component	Preventative Maintenance Operation	Maintenance Interval (Months unless otherwise indicated)										
		See Note Below	As Needed	Daily	Monthly	4	6	12	24	36	48	60
<b>Purge Pump</b>	Inspection of belt - replace or tighten as needed						O					
	Check operating amperage of pump				O							
	Check electrical connections to pump						T					
	Inspection of pump contactor and overload						T					
	Change oil		O									
	Determine ultimate vacuum of pump						T					
	Rebuild or replace pump		T									
<b>Purge System</b>	Rebuild Purge Diaphragm Valves		T									
	Accuracy check of manometer or Vacuum Gauge						T					
<b>Tube Bundles</b>	Clean tubes in absorber, condenser, evaporator & hot water heat exchanger (where applicable)							T				
	Eddy current inspection	(4)										
<b>Steam (Steam-Fired Units only)</b>	Inspection for wear of steam valve - Rebuild or replace as needed							T				
	Check for proper steam valve modulation							T				
	Inspect steam system piping and components for leaks			O								
	Inspect for design steam entering conditions			O								

**NOTES:**

- Units that provide year-round cooling:** Once every four months, and as required due to excess purge requirements.  
**Units that provide only seasonal cooling:** Once at the beginning of the cooling season, once in the middle, and as needed due to excess purge requirements.
- Units should be leak-tested when excessive purging is required. **Note:** The solution chemistry should always be checked (and adjusted as necessary) prior to performing a leak test.
- More frequent rebuilds will be required if solids and/or dissolved copper is present in the solution.
- Perform every 2-3 years or as required.

T = YORK Qualified Service Technician

O = Operator

## GLOSSARY OF TERMS

### **Absorber:**

The concentrated solution coming back from the generator is pumped to a solution spray header where it is sprayed over the tubes in the absorber. Refrigerant vapor is absorbed into the solution and the solution is thus diluted. This diluted solution is collected at the bottom of the absorber where it is again pumped to the generator.

### **ADC Flush Line:**

This line runs between the solution pump discharge and the ADC line. When the solution pump runs, weak solution is constantly supplied to the ADC line. This keeps the ADC line from crystallizing, due to it being exposed to the low pressures generated within the absorber while the unit is running.

### **ADVAGuard™ 750:**

YORK's newest Inhibitor. An inorganic inhibitor providing excellent corrosion protection to the unit's internal steel and copper surfaces. Also see *Inhibitor*.

### **Alcohol (2-Ethylhexanol):**

A liquid added to an absorption chiller to enhance the heat and mass transfer in the Absorber. It is an octyl alcohol whose chemical name is 2-Ethyl-1-Hexanol (C<sub>8</sub>H<sub>18</sub>O) with a molecular weight of 130.2, a boiling point of 364.3°F, and a flash point of 177.8°F @ 760 mmHg. Having a colorless, clear appearance, it has a somewhat pungent odor. By adding 2-Ethylhexanol to the absorption cycle, overall unit performance increases by 5-15%. In addition, cycle temperatures, pressures, and concentrations tend to decrease with the addition of 2-Ethylhexanol.

### **Automatic De-crystallization Pipe (ADC):**

The automatic de-crystallization pipe is a U-shaped line coming off the generator solution outlet box and terminating in the absorber shell. During normal unit operation, this line has no flow in it. If crystallization were to occur, it would normally be in the strong solution side of the heat exchanger. This blockage would back up solution into the generator solution and into the automatic de-crystallization pipe. Once the hot solution goes into the ADC pipe, it bypasses the heat exchanger and goes directly into the absorber shell, thus heating the solution in the absorber shell. The heated solution in the absorber then heats up the crys-

tallized heat exchanger from the opposite side of the tubes and causes the crystallized lithium bromide to dissolve back into solution.

### **Blowdown:**

While running the unit, refrigerant is intentionally dumped into the absorber shell section by opening 2SOL (stabilizer solenoid valve). A refrigerant blowdown will further dilute the solution in the absorber shell. A blowdown is required before taking a solution sample for analysis, to separate the alcohol from the refrigerant, and to hasten the refrigerant clean-up procedure.

### **C.O.P.:**

Coefficient of performance. A means of comparing the performance of a chiller as the ratio of the cooling output divided by the heat input.

### **Concentration:**

The percent by weight of lithium bromide present in solution. New solution is sent with a concentration of 54% if the inhibitor is ADVAGuard 750, or 55% if the inhibitor is molybdate.

### **Condensate:**

Condensed steam leaving the unit.

### **Condenser:**

Vapor produced by the generator enters the condenser and is cooled and condensed back into a liquid by the tower water flowing through the inside of the condenser tubes. The condensed vapor liquid drips down into a collection pan located at the bottom of the condenser. From there it flows out of the pan, through an orifice, and into the evaporator.

### **Condenser (Tower) Water:**

The external water loop which is used to remove heat from the unit. This water passes first through the Absorber, then the Condenser. Typical temperatures are entering the Absorber at 85°F, leaving the Absorber (entering the Condenser, i.e. crossover) at 92°F, and leaving the Condenser at 95°F. Some external means of removing this heat is necessary. Typically a cooling tower is used for this application.

### **Crystallization:**

Under certain conditions, lithium bromide solution may increase in viscosity and become slush-like, or even solidify. The likelihood of solution crystallizing increases as the concentration increases and/or the temperature decreases. For reference, here are some points where the liquid solution of lithium bromide will crystallize, assuming a saturation condition: 240°F @ 70%; 207°F @ 69%; 182°F @ 68%; 158°F @ 67%; 138°F @ 66%; and 120°F @ 65%. Typically, crystallization occurs where the heated, high concentrated solution leaves the generator and passes through the heat exchanger. This is where the solution is at its highest concentration that meets the lowest temperature. Under normal running conditions, crystallization is not a problem. Extreme cold ambient temperatures, power failures, and unit air leakage are the typical causes for crystallization.

### **Dilution Cycle:**

Intentionally running the solution, refrigerant, tower water, and chilled water pumps after unit has been shut down to allow the concentrated solution to become more dilute. Essentially, the cycle continues without the addition of heat, thus, slowly diluting the solution to concentration levels where it is more difficult to crystallize. The dilution cycle will shut off after the solution temperature reaches 136°F. **Note: The dilution cycle is dependent upon many factors. Please see the micropanel instructions for details.**

### **Eductor:**

An eductor is a liquid-powered jet pump. Jet pumps have no moving parts and use a high-pressure stream of liquid to pass through a nozzle, causing a portion of a low-pressure stream coming into the side of the pump to combine with the nozzle stream. This causes a reduction in pressure at the low-pressure inlet and induces the rest of the low-pressure inlet substance to flow into the body of the pump.

On IsoFlow™ units, an eductor is used in place of a centrifugal pump to induce strong concentrated solution exiting the generator outlet box to combine with weak concentrated solution exiting the solution pump discharge, before going to the absorber spray header.

### **Evaporator:**

The section of a chiller that is responsible for removing the heat from the chilled water circuit, thus cool-

ing the chilled water to be used to cool a building, a manufacturing process, or whatever application it is intended. Typically, the chilled water is cooled from 54°F to 44°F. In an absorption chiller, the pure refrigerant generated in the generator is cooled and condensed in the Condenser and supplied to the Evaporator. Here, it is immediately exposed to a much lower pressure which causes some immediate flashing (boiling). Most of the refrigerant cools to the saturation temperature and remains in liquid form. It is then pumped and sprayed over the Evaporator tube bundle. As the refrigerant passes over the outer surface of the tubes, it evaporates (i.e. flashes or boils) because of the low pressure, approximately 5.5-6.5 mmHg which is equivalent to a saturation temperature of 36-41°F. The refrigerant vapor is then immediately drawn through the eliminator towards the Absorber. This vacuum is caused by the hygroscopic action, the affinity Lithium Bromide has for the refrigerant vapor.

### **Evaporator Sprays:**

A series of spray nozzles that evenly distribute refrigerant from the refrigerant pump discharge to the evaporator section tubes.

### **Float (1F), (3F):**

There are two floats that sense liquid levels on the IsoFlow units. Both are located in the refrigerant circuit. Float (1F) is at the side of the evaporator refrigerant outlet box, and senses the level in the box. At low levels in this box, the 1F float will open, causing the micropanel to initiate corrective procedures to keep the unit from running out of refrigerant. *For more details, see YORK Form 155.16-03.*

Float (3F) is located just before the inlet of the Buffalo refrigerant pump. It's main purpose is to keep the Buffalo pump from cavitation and eventual overheating. *For more details on the operation of this float, see YORK Form 155.16-03.*

### **Generator:**

This component of the absorption system heats diluted lithium bromide solution coming from the absorber shell. The generator can receive its heat source from either hot water to 266°F (130°C) and 300 PSIG or steam of up to 337°F (169°C) and 15 PSIG. As the solution is heated, refrigerant vapor is boiled off and rises to the condenser. The resulting concentrated lithium bromide solution flows back to the absorber sprays.

**G.P.M.:**

A measure of volumetric flow rate (Gallons Per Minute).

**Hot Water Valve:**

The capacity control valve that regulates the amount of hot water to the generator (hot water units only).

**Inhibitor:**

A chemical used to help minimize or inhibit the corrosion of the internal steel surface area of the unit. It works by chemically slowing down the natural tendency of steel to oxidize or corrode. YORK's current inhibitor is Lithium Molybdate ( $\text{Li}_2\text{MoO}_4$ ) and ADVAGuard™ 750.

**Insulation:**

Units should be insulated in the field according to the installation manual. Insulation should be installed for a variety of reasons:

1. Decreases the heat loss through the walls of the vessel to its surroundings, thus increasing the efficiency of the machine.
2. Helps reduce the potential of crystallization in the event of a power failure.
3. Burn protection for operating personnel in high temperature areas.
4. Eliminates condensation on low temperature areas of the machine.

**IsoFlow™**

Our trademark name for a single-stage absorption unit.

**Isolation Valve:**

One isolation valve is located at each Buffalo Pump inlet and outlet. It is a positive sealing, butterfly type valve mounted between standard ANSI flanges. Each valve incorporates an EPDM liner on the valve face to act as a sealing surface. When closed, the valves will isolate the unit vacuum from the pump area to offer ease of serviceability when working on the pumps.

**Micropanel:**

The "brains" of the unit. The micropanel is the electronic control panel which instructs the entire unit on when and how to run. Integrated into the logic of the

micropanel are sensors to measure key temperatures and pressures which are then used to monitor real-time conditions.

**Model Number:**

A series of abbreviations or designations used to identify IsoFlow™ units.

**Molybdate:**

(Lithium Molybdate,  $\text{Li}_2\text{MoO}_4$ ). The current corrosion inhibitor used for York's absorption units. By chemically slowing down the natural tendency of steel to oxidize or corrode, the inhibitor is supplied in solution with the Lithium Bromide. See also Inhibitor.

**Non-Condensables:**

A gaseous substance that cannot be liquified or condensed at the pressure and temperature surrounding it. The presence of non-condensables in the unit can cause severe performance problems. Non-condensables appear in two forms in the unit: 1. Internally generated non-condensables are formed as a by-product of corrosion; 2. Air may be drawn into a unit via leaks.

Non-condensables that collect in the absorber section of the unit blanket the heat transfer tubes and raise the internal pressure, thus reducing the absorber's ability to capture the refrigerant vapor. Non-condensables that collect in the high side of the unit end up in the condenser section, where they blanket the condenser tubes, reducing the condenser's capacity.

It should be noted that the only non-condensable that is not self-generated by the chemistry inside the unit is nitrogen. Air is over 70% nitrogen; an air leak is the only external source of nitrogen. All other non-condensables are generated by various chemical reactions that occur internally for many different reasons.

**Oil Trap:**

The oil trap is located between the purge pump suction connection and the unit. It is designed so it will hold one complete oil charge of the vacuum pump. In the event air was to get into the unit through the vacuum pump, the low pressure in the absorber would induce the oil onto the system. Therefore, the oil trap is used as a safety measure to protect the absorption unit from the oil.

**Orifice:**

A restriction in a liquid line for the purpose of reducing the internal diameter of the line. Usually created by a blank piece of metal with a small hole drilled into it, to create a pressure differential when a liquid passes through it.

**Pass Baffle:**

A division plate or plates (baffles) inserted into a water box to create chambers which force the water to pass through different portions of the tube bundle, called passes. Although the pressure drop increases with increasing passes, the tradeoff for heat transfer optimization and nozzle locations are justified.

**Power Panel**

The power panel serves as single-point wiring location for the unit's incoming power wiring. It houses all the unit pump contactors and overloads, as well as fuses and terminal lugs for ease of serviceability. A transformer is included to reduce the incoming unit voltage to the required control voltage to the micropanel.

**Pressure Drop:**

The amount of pressure decrease experienced between two locations. Often referred to when describing the drop in pressure found while passing water through the tubes in a chiller. Typically measured in PSI or Ft H<sub>2</sub>O

**Purge Drum:**

The purge chamber is also sometimes called the purge drum. It was designed to produce a low-pressure area so that non-condensables can be pulled out of the absorption system and expelled to the atmosphere by the purge pump.

The purge drum functions similar to the way that the absorber section of the system functions. Tower water circulates through a coil inside the purge drum while solution is sprayed over the outside of the coil. This process induces the non-condensables in the absorber shell to enter a purge header assembly with the shell and migrate to the purge drum. Once inside the purge drum, the vacuum pump can pull the non-condensables out of the drum and expel them to the atmosphere.

**Purge Pump:**

An external pump connected to the purge system of the unit. This pump is used to evacuate non-condensables from the unit.

**Purging:**

A process by which non-condensables present in a unit are removed through the use of a vacuum pump.

**Refrigerant:**

(Water, H<sub>2</sub>O). Deionized water is used as the refrigerant.

**Refrigerant Anti-Freeze Line:**

This line runs between the outlet of the refrigerant pump and the refrigerant condensate line(s) coming down off the condenser. When the refrigerant pump is operating, a constant supply of refrigerant is supplied to mix with the refrigerant coming from the condenser to keep it from freezing during low loads and low condenser water temperatures.

**Refrigerant Pump:**

A hermetically sealed, centrifugal pump located downstream of the evaporator outlet box. This pump receives liquid refrigerant from the evaporator and discharges it back up to the evaporator sprays. It continues to re-circulate the refrigerant while the chiller is operational.

**Rupture Disk (Hot Water Units Only):**

Although IsoFlow™ absorption units operate at less than atmospheric pressure (a vacuum), if certain safeties fail and/or incorrect valves are closed, the unit could experience higher pressures in certain chambers. Therefore, a pressure relief apparatus, a rupture disk, is added.

**Sight Glass:**

A leak tight port hole used to visually inspect liquid levels within the unit. A threaded design with a quartz glass window is presently being used.

**Solution:**

A mixture of deionized water with a certain % by weight of dissolved lithium bromide (LiBr). Corrosion inhibitors are also added to the solution to reduce the internal corrosion rates in the unit.

**Solution Heat Exchanger:**

A counterflow Solution To Solution heat exchanger. A component that exchanges heat between two streams of Lithium Bromide solution. The hotter the solution being supplied to the generators is, the less heat that needs to be added, thus improving efficiency. Likewise, the cooler the solution is going to the Absorber, the less heat that needs to be removed by the cooling towers. Therefore, the heat exchanger preheats the solution going to the generator and cools the solution going to the Absorber.

**Solution Pump:**

A hermetically sealed, centrifugal pump located under the absorber. It receives diluted lithium bromide solution from the absorber shell and circulates it through a heat exchanger, then up to the generator. The discharge of this pump operates in a pressure that is above atmospheric pressure. The pump is cooled by the solution it is pumping.

**Specific Gravity (S.G.):**

The ratio of the mass a liquid to the mass of an equal volume of distilled water at 39°F.

**Steam Valve:**

The capacity control valve which regulates the amount of steam to the unit (Steam units only).

**Tube Sheet (End Sheet):**

The book-ends of the mainshell. The tube sheets are located at each of the axial ends of the unit, where the tubes are rolled and waterboxes are mounted.

**Tube Support:**

A smaller gauge steel sheet, identical in tube hole layout to the tube sheet, but used internally to provide support and rigidity for the bundle of tubes.

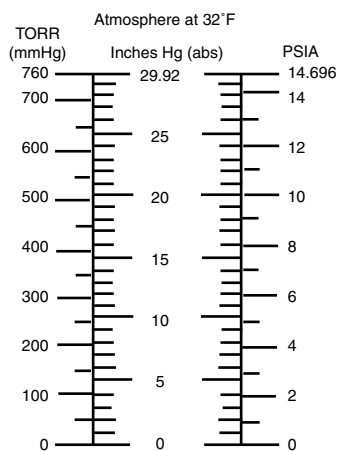

LD05113

FIG. 25 – PRESSURE EQUIVALENTS

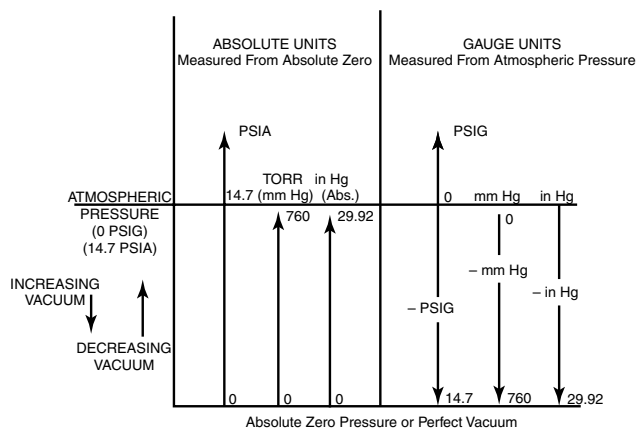

LD05114

FIG. 26 – VACUUM UNITS OF MEASUREMENT

**Vacuum:**

When the pressure within a vessel is less than standard atmospheric pressure.

The term “vacuum” usually refers to any pressure below atmospheric pressure. The degree of vacuum can be expressed in many ways, but most commonly, as in this manual, it is measured in inches of mercury or millimeters of mercury.

One atmosphere is equal to 760 millimeters of mercury absolute (Torr); 29.92 inches of mercury absolute; or 14.7 pounds per square inch absolute (see Fig. 25).

When vacuum is measured relative to atmospheric pressure and toward absolute zero, the negative sign (–) is used to indicate that it is a negative gauge pressure value. When vacuum is considered in the other direction, i.e., from absolute zero, the term absolute (or abs.) is used (See Figure 26).

From Figure 25, we can see that a pressure reading of 300 Torr is the same as 11.8 in Hg (abs.) and 5.8 PSI (abs.).

**Water Box:**

A structure designed to contain the water both entering and exiting the unit by using nozzles to restrict the water into a contained area. The nozzle directs the water into the waterbox where pressure builds up, forcing the water through the tubes. As the water exits the tubes on the opposite end, it is restricted by the waterbox on the other side of the tube bundle. Again, pressure builds up, and the water is either forced by a pass baffle back through another section of the tube bundle or directly out of the outlet nozzle.

**YIA:**

YORK IsoFlow™ Chiller

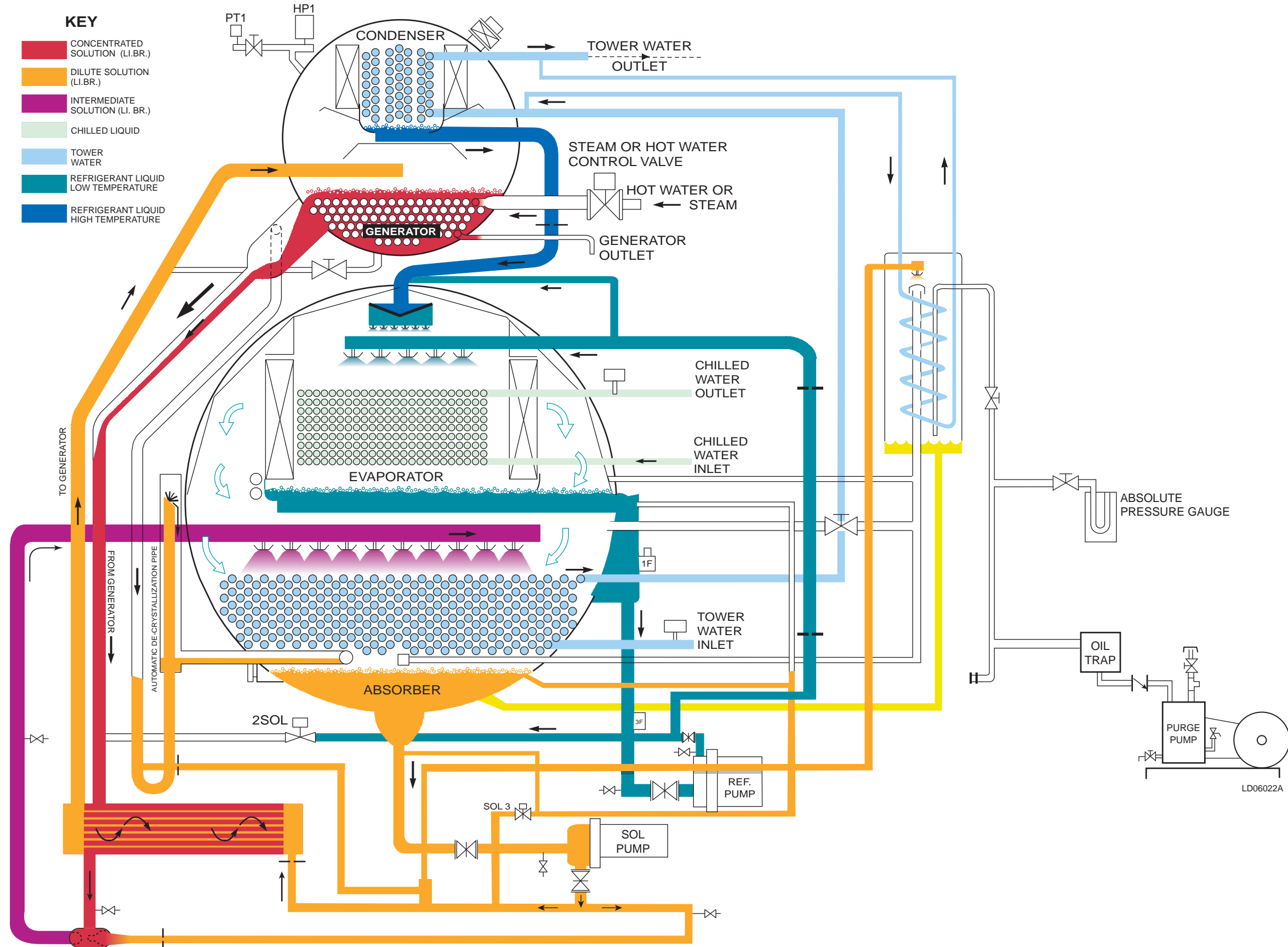

\* Orifices may differ between various models.

FIG. 27 – COMPLETE CYCLE DIAGRAM

