

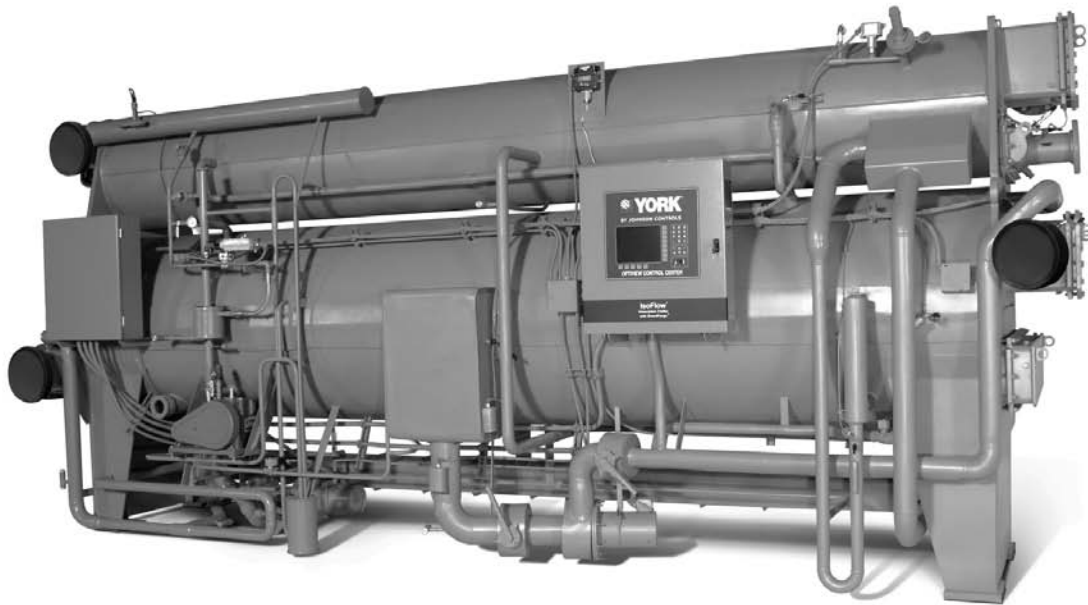

BY JOHNSON CONTROLS



YIA Single-Effect Absorption Chillers Steam And Hot Water Chillers



120-1377 TONS
(420 - 4840 kW)

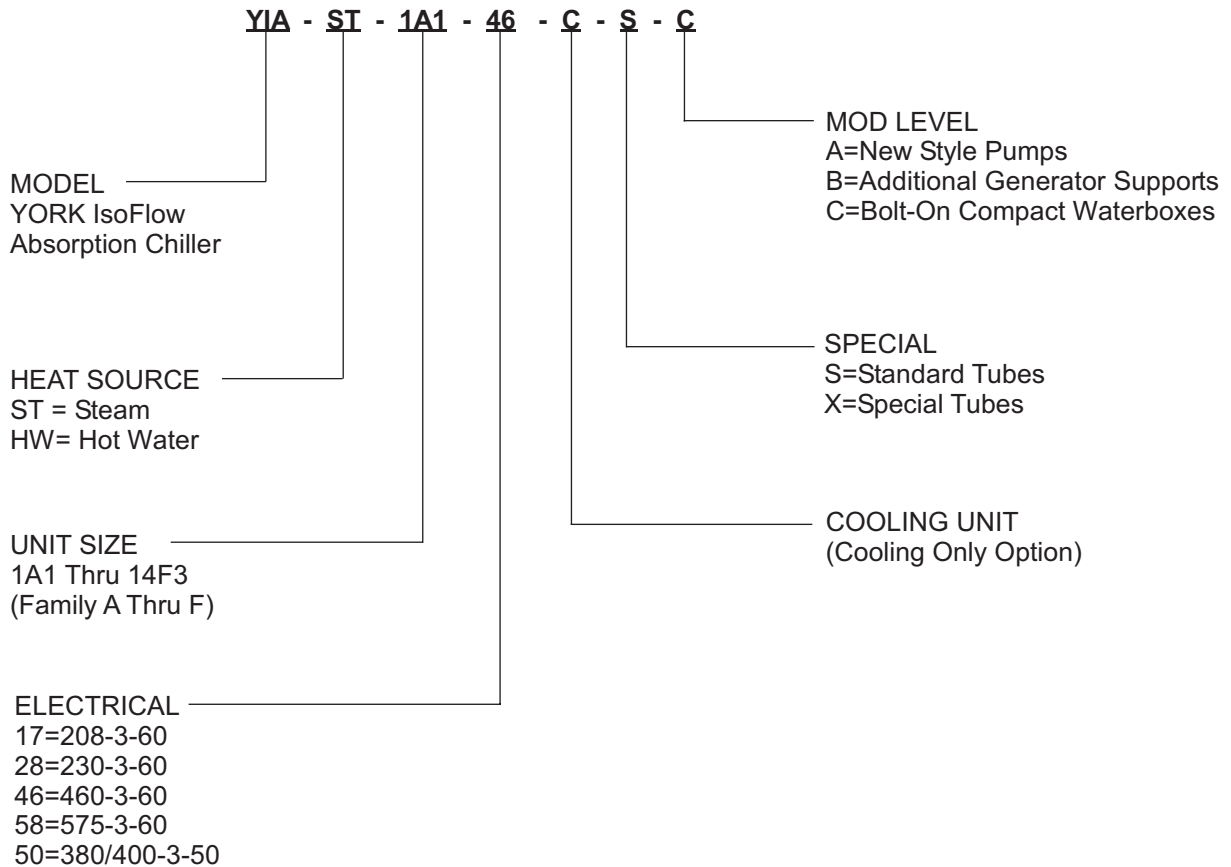

Table of Contents

FORM 155.16-EG3 (1010) 1
Introduction..... 3
OptiView Control Center..... 4
Reliability Features..... 10
How It Works..... 14
Mechanical Specifications..... 16
Optional Features..... 19
Application Data..... 20
Ratings..... 40
Nozzle Arrangements..... 44
Physical Data..... 46
Electrical Data..... 49
Guide Specifications..... 51

NOMENCLATURE

The model number denotes the following characteristics of the unit:



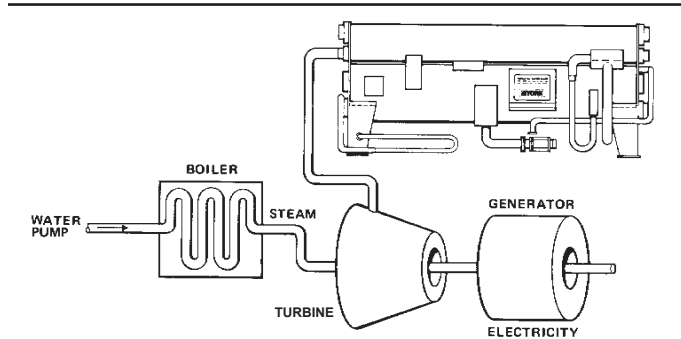

COGENERATION

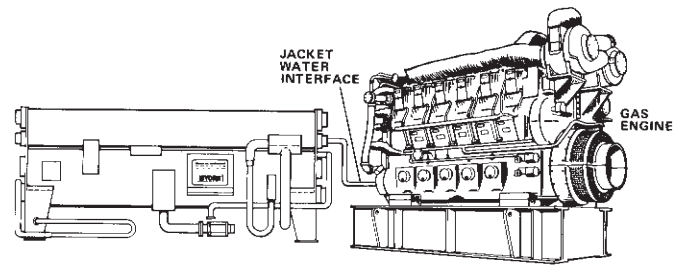

WASTE HEAT RECOVERY

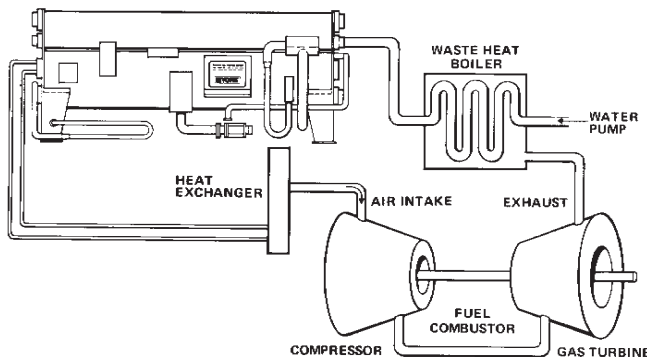

INLET AIR COOLING

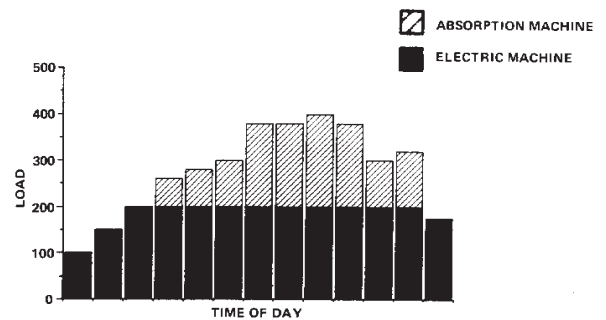

PEAK SHAVING/COMMERCIAL COOLING

Today's environmental and energy considerations demand innovative chiller plant designs which save expensive peak load kW hours and eliminate CFC's. In a growing number of applications with waste heat or abundant low pressure steam, single-stage absorption chillers offer an ideal means of saving on cooling costs without a significant installation cost penalty.

That's why Johnson Controls is proud to introduce the **YIA** Single-Stage Absorption Chiller. The **YIA** Absorption Chiller offers the rugged, industrial grade design of our previous single effect model, with a whole new package of user friendly microprocessor controls, designed to increase reliability and enhance performance.

Applications particularly well suited for the YORK **YIA** Absorption Chiller include the following:

Combined Heat & Power or Cogeneration – For CHP systems, high pressure steam has many valuable uses, while low pressure steam or hot water is considerably less useful, yet more plentiful. In these plants, the **YIA** absorber can provide cooling with low pressure steam or hot water, freeing high pressure steam for power generation or other valuable uses.

Inlet Air Cooling – Use a **YIA** chiller to cool inlet air to a gas turbine or a compressor. The lower specific volume associated with cooler air provides more combustion capacity by increasing the overall efficiency of the system.

Waste Heat Recovery – Recover waste heat from printing plants, incinerators or gas engine jacket water to provide required comfort or process cooling at little operational cost.

Commercial Cooling/Peak Shaving – For particularly pronounced peak loads with few operating hours, the **YIA** absorber's lower first cost may provide an acceptable payback when more efficient, yet more expensive double effect chillers cannot.

For these and similar money saving designs, consider the field proven **YIA** design. In over thirty-five years of operation, the YORK single-effect design has proven itself in applications ranging from schools to refineries. Now, with state of the art controls and continual product improvement, the YORK **YIA** absorption chiller is truly without peer. When it comes to absorption technology, there's only one leader - Johnson Controls

OptiView Control Center

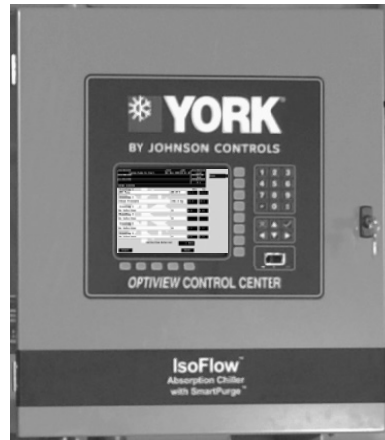

YIA OPTIVIEW CONTROL CENTER WITH SMART-PURGE

The YORK **YIA** OptiView Control Center, furnished as standard on each chiller, provides the ultimate in efficiency, monitoring, data recording, chiller protection and operating ease. The Control Center is a factory-mounted, wired and tested state-of-the-art microprocessor based control system for lithium bromide absorption chillers. The panel is configured with a 10.4-in. (264 mm) diagonal color Liquid Crystal Display (LCD) surrounded by “soft” keys, which are redefined with one keystroke based on the screen displayed at that time. This revolutionary development makes chiller operation quicker and easier than ever before. Instead of requiring keystroke after keystroke to hunt for information on a small monochrome LCD screen, a single button reveals a wide array of information on a large, full-color illustration of the appropriate component, which makes information easier to interpret. This is all mounted in the middle of a keypad interface and installed in a locked enclosure.

The LCD display allows graphic animated display of the chiller, chiller sub-systems and system parameters; this allows the presentation of several operating parameters at once. In addition, the operator may view a graphical representation of the historical operation of the chiller as well as the present operation. A Status Bar is displayed at all times on all screens. It contains the System - Status Line and Details Line, the Control Source, Access Level, Time and Date.

The panel verbiage is available in eight languages as standard and can be changed on the fly without having to turn off the chiller. Data can be displayed in either English or Metric units plus keypad entry of setpoints to 0.1 increments.

Security access is provided to prevent unauthorized changes of setpoints. This is accomplished with three different levels of access and passwords for each level. There are certain screens, displayed values, programmable setpoints and manual controls not shown that are for servicing the chiller. They are only displayed when

logged in at service access level. Included in this is the Advanced Diagnostics and troubleshooting information for the chiller and the panel.

The panel is fused through a 1.0 KVA transformer in the power panel to provide individual over-current protected power for all controls. Numbered terminal strips for wiring such as Remote Start/Stop, Flow Switches, Chilled Water Pump and Local or Remote Cycling devices are provided. The Panel also provides field interlocks that indicate the chiller status. These contacts include a Remote Mode Ready-to-Start, a Cycling Shutdown, a Safety Shutdown and a chiller Run contact. Pressure transducers sense system pressures and thermistors sense system temperatures. The output of each transducer is a DC voltage that is analogous to the pressure input. The output of each thermistor is a DC voltage that is analogous to the temperature it is sensing.

Setpoints can be changed from a remote location via 010VDC, 4-20mA, contact closures or through serial communications. The adjustable remote reset range [up to 20°F (11.1°C)] provides flexible, efficient use of remote signal depending on reset needs. Serial data interface to the Building Automation System (BAS) is through the optional

E-LINK, WHICH CAN BE MOUNTED INSIDE THE CONTROL CENTER

This printed circuit board requests the required data from the Microboard and makes it available for the Johnson Controls Metasys® network. This optional board is available through the Johnson Controls Building Efficiency group. The operating program is stored in non-volatile memory (EPROM) to eliminate chiller failure due to AC power failure/battery discharge. Programmed setpoints are retained in lithium battery-backed RTC memory for 10 years minimum.

Every programmable point has a pop-up screen with the allowable ranges, so that the chiller cannot be programmed to operate outside of its design limits.

When the power is applied to the chiller, the HOME screen is displayed. This screen displays a visual representation of the chiller and a collection of data detailing important operations and parameters. When the chiller is running the flow of chilled liquid is animated by the alternating shades of color moving in and out of the pipe nozzles. The primary values that need to be monitored and controlled are shown on this screen. They are as follows:

Programmable

- Login/Logout – View, Operator, or Service Modes
- Print
- Warning Reset
- Soft Shutdown

Display Only

- Chilled Liquid Temperature – Leaving
- Chilled Liquid Temperature – Returning
- Condenser Liquid Temperature – Returning
- Condenser Liquid Temperature – Leaving
- Total Operating Hours
- Latest Run Time
- Number of Starts
- Chilled Liquid Flow (On/Off)
- Cooling Liquid Flow (On/Off)

Navigation

- Evaporator/Absorber
- Generator/Condenser
- System
- Purge
- Control Valve
- Setpoints
- Sales Order
- History

With the “soft” keys the operator is only one touch away from the 7 main screens that allows access to the major information and components of the chiller. The 7 screens are the **EVAPORATOR/ABSORBER, GENERATOR/CONDENSER, SYSTEM, PURGE, CONTROL VALVE, SETPOINTS, SALES ORDER**, and the **HISTORY**. Also on the Home screen is the ability to initiate a Soft Shutdown, Log In, Log Out, Print, Warning Reset. Log In and Log Out is the means by which different security levels are accessed.

The **EVAPORATOR/ABSORBER** screen displays a cutaway view of the chiller evaporator/absorber shell. All setpoints relating to the evaporator side of the chiller are maintained on this screen. Animation of the evaporation process indicates whether the chiller is presently in **RUN** condition (bubbling) and liquid flow in the pipes is indi-

cated by alternating shades of color moving in and out of the pipes. Adjustable limits on the low water temperature setpoints allow the chiller to cycle on and off for greater efficiency and less chiller cycling. The chiller cycles off when the leaving chilled water temperature is below setpoint and is adjustable from 1°F (0.55°C) below to a minimum of 40°F (4.4°C). Restart is adjustable from setpoint up to a max of 77°F (25.0°C). The panel will check for flow to avoid freeze up of the tubes. If flow is interrupted shutdown will occur after a minimum of two seconds. From this screen you can perform the following.

Programmable

- Leaving Chilled Liquid Temperature – Setpoint

Display Only

- Chilled Liquid Temperature - Returning
- Chilled Liquid Temperature – Leaving
- Refrigerant Temperature
- Stabilizer/Unloader Valve (Open/Closed)
- Refrigerant Level Switch (Open/Closed)
- Cooling Liquid Temperature - Returning

Navigation

- Home Screen
- Generator/Condenser
- System
- Purge

The **GENERATOR/CONDENSER** screen displays a cutaway view of the chiller generator/condenser shell. The liquid flow is animated to indicate flow through the generator and condenser. All setpoints relating to the generator and condenser side of the chiller are maintained on this screen. From this screen you can view the following:

Display Only

- Generator Shell Side Pressure
- Steam or Hot Water Inlet Temperature
- Steam or Hot Water Inlet Pressure
- Strong Solution Temperature
- Strong Solution Concentration
- Automatic Decrystallization Temperature
- Solution Temperature Leaving the STS
- Minimum Temperature to Crystallize
- Condense Leaving Cooling Liquid Temperature
- Refrigerant Temperature from the Condenser
- Control Valve Mode

Navigation

- Home Screen
- Evaporator/Absorber

OptiView Control Center - continued

- System
- Purge

The **SYSTEM** screen gives a general overview of common chiller parameters for both shells. This is a view of the refrigerant tank and pump. With the proper access level, this screen also serves as a gateway to controlling the Dilution Cycle. From this screen you can view the following.

Display Only

- Solution Pump (On/Off)
- Solution Pump Mode (Auto/Manual)
- Refrigerant Pump (On/Off)
- Refrigerant Pump Mode (Auto/Manual)
- Condenser Liquid Flow (On/Off)
- Condenser Pump Mode (Auto/Manual)
- Condenser Liquid Flow Switch Opened/Closed)
- Chilled Liquid Pump (On/Off)
- Chilled Liquid Pump Mode (Auto/Manual)
- Chilled Liquid Flow Switch (Open/Closed)
- Stabilizer Valve Status (2 SOL) (Open/Closed)
- Unloader Valve Status (3 SOL) (Open/Closed)
- Refrigerant Level Switches (Open/Closed)

Navigation

- Home Screen

The **PURGE SYSTEM** screen displays a view of the purge pump, purge tank and piping. This screen also serves as a gateway to sub-screens for manual purge pump operation, and criteria for purge trending set-up and purge data collection. From this screen you can view the following:

Programmable

- Repair - assists with trouble shooting the purge system
- Maintenance Mode – allows the chiller to run during purge pump maintenance

Display Only

- Purge Pump Pressure
- Purge Tank Pressure
- Last 7 Days Purge Counter
- Auto Count – Automatic Purge Cycles Last 7 Days
- Manual Count – Manual Purge Cycles Last 7 Days
- Autopurge Total Counter
- Manual Purge Total Counter
- Purge Mode
- Purge Pump (On/Off)
- 7SOL – Purge Valve (Open/Closed)
- 8SOL – Purge Valve (Open/Closed)

Navigation

- Home Screen
- Evaporator/Absorber
- Generator/Condenser
- System
- Purge Trend
- Purge Pump

The **PURGE TREND** screen displays graphical data for tracking the purge tank pressure over a selected time period for trouble shooting and purge frequency data collection. From this screen you can view the following:

Programmable

- Chart Type
- Interval 1 – 24 hours
- Start/Stop Trending
- Minimum Pressure Value
- Maximum Pressure Value

Display Only

- Purge Tank Pressure Differential Chart

Navigation

- Home Screen

The **CONTROL VALVE** screen displays a close-up view of the steam or hot water modulating control valve. This screen also allows manual control of the control valve and allows numerous limits to be applied to the control valve functionality when the panel is in the Service Mode. From this screen you can perform the following:

Display Only

- Valve Part Number
- Valve Description
- Valve Type
- Load Limit Values

Navigation

- Home Screen

The **SETPOINTS** screen provides a convenient location for programming the most common setpoints involved in the chiller control. The Setpoints are shown on other individual screens but to cut down on needless searching they are on this one screen. This screen also serves as a gateway to the Diagnostics screen for service troubleshooting. From this screen you can perform the following:

Programmable

- Max Purge per Week
- Manual/Auto Restart After Power Failure
- Refrigerant Pump Shutdown Time Setpoint
- Percent Valve Open
- Low Leaving Chilled Liquid Offset
- Pulldown Demand Limit
- Pulldown Loading StopSetpoint
- Pulldown Loading Sart Setpoint
- Pulldown Interval Timer
- Ramp Down Interval Setpoint
- Print

Display Only

- Operational Setpoints
- Pulldown Demand Setpoints

Navigation

- Home Screen
- Operation
- Schedule
- Pulldown

The **SCHEDULE** screen allows for daily starting and stopping of the chiller and permits different stop/stop times for each day of the week. The **SCHEDULE** screen permits 14 holidays to be programmed separately as defined by the user.

Programmable

- Daily Schedule
- Time On/Off
- Repeat Sunday
- Holiday (up to 14 per year)

The **USER** screen allows definition of the language for the chiller to display and defines the unit of measure.

Programmable

- System Language
- English/Metric Units

The **COMMS** screen allows definition of the necessary communications parameters.

Programmable

- Chiller ID
- Com 2 Baud Rate
- Com 2 Data Bit(s)
- Com 2 Parity Bit(s)
- Com 2 Stop Bit(s)

- Printer Baud Rate
- Printer Data Bit(s)
- Printer Parity Bit(s)
- Printer Stop Bit(s)

The **PRINTER** screen allows Definition of the necessary communications Parameters for the printer.

Display Only

- Time Remaining Until Next Print Programmable
- Log Start Time
- Output Interval
- Automatic Printer Logging (Enabled/Disabled)
- Print Type
- ACC Auto Map Print (Enable/Disabled)
- ACC Map Report
- Print Report
- Print All Histories

The **SALES ORDER** screen shows details of the sales order information and performance conditions at time of sale. This information is loaded by factory personnel just prior to shipping the chiller.

Programmable

- Print

Display Only

- Model Number
- Panel Serial Number
- Chiller Serial Number
- Johnson Controls Order Number
- System Information
- Evaporator, Condenser/Absorber, and Generator Design Load Information
- System Information

Navigation

- Home Screen

The **HISTORY** screen allows the user to browse through the system faults. Details of Safety Shutdowns, Cycling Shutdowns, Start Inhibits, and Warning history can be viewed from this screen.

Display Only

- Safety Shutdowns History File
- Cycling Shutdown History File
- Start Inhibit History File
- Warning History File
- View Details

OptiView Control Center - continued

- Print Details
- Print File

Navigation

- Home
- Trending
- Safeties
- Cycling
- Inhibit
- Warnings
- Last Normal Stop

Also under the History screen is the **TRENDING** screen, accessible by the key marked the same. On this screen up to 6 operator-selected parameters selected from a list of over 140, can be plotted in an X/Y graph format. The graph can be customized to record points once every second up to once every hour. There are two types of charts that can be created: a single or continuous screen. The single screen collects data for one screen width (450 data points across the x-axis) then stops. The continuous screen keeps collecting the data but the oldest data drops off the graph from left to right at the next data collection interval. For ease of identification, each plotted parameter, title and associated Y- axis labeling is color coordinated.

Display Only

- Trending 1 thru Trending 6

Programmable

- Trending 1 thru Trending 6
- Purge Tank Pressure
- Purge Pump Pressure
- Refrigerant from Condenser
- Leaving STS
- Strong Solution Concentration
- Strong Solution Temperature
- Min. Temperature to Crystallize
- Steam Supply Pressure
- Steam Supply Temperature
- Generator Pressure
- Refrigerant Temperature
- Total Operating Hours
- Leaving Cooling Liquid Temperature
- Returning Cooling Liquid Temperature
- Leaving Chilled Liquid Temperature
- Returning Chilled Liquid Temperature
- Steam/Hot Water Valve Position
- Trend Setup
- Start Trend

- Stop Trend
- Min – minimum trend value
- Max – maximum tend value

Navigation

- Home
- Trend Setup

The **TREND SETUP** screen is used to configure the trending screen.

Programmable

- Chart Type
- Collection Interval

Navigation

- Home
- Trending
- Triggers

Under the Trend Setup screen is a Trigger screen. This option allows the operator to select desired data collection start/stop triggers. The trend data collection can be set to start or stop based upon the status of up to two selected triggers. The triggers can consist of digital events or analog parameters compared to thresholds. The triggers can be used individually or in combination.

The Control Center continually monitors the operating system displaying and recording the cause of any shut-downs (Safety, Cycling or Normal). The condition of the chiller is displayed at the System Status line that contains a message describing the operating state of the chiller; whether it is stopped, running, starting or shutting down. A System Details line displays Warning, Cycling, Safety, Start Inhibit and other messages that provide further details of Status Bar messages. Messages are color-coded: Green – Normal Operations, Yellow - Warnings, Orange – Cycling Shutdowns, and Red – Safety Shutdowns to aid in identifying problems quickly.

Status Messages include:

- System Ready to Start
- System Starting
- System Running
- Cycling Shutdown – Auto Restart
- Safety Shutdown – Manual Restart
- System Start Inhibited
- Control Valve Calibration in Progress
- Control Valve Calibration is Successful
- Disabled Warnings have been Erased
- Purge Pump Off
- Purge Pump Valve Closing

Run Messages include:

- ADC in progress – load Limit to 50%
- Cooling Start Sequence Initiated
- Dilution Cycle is in progress
- High Concentration Control in Effect
- Leaving Chilled Liquid Temperature Control in Effect
- Primary Limited ADC in Progress – Load set to 50%
- Secondary Limited ADC in Progress
- Unit Load has reached the Maximum Load Limit Setpoint
- Unit Load has reached the Remote Load Limit Setpoint
- Unit Load is Controlled by Pulldown Demand Limit
- Unit Load is Controlled by Rampdown Limit
- Unit Load is set to 30%

Start Inhibit Messages include:

- Auxiliary Safety Shutdown
- Generator Hi-press Analog
- Steam/HW Valve loaded >10% close to 9% to restart
- Leaving Chilled Liquid Temp < Setpoint
- Low refrigerant Temperature
- Unit Shutdown by Multiunit Remote
- Unit in Standby until power supply recovers
- Unit Shutdown by Remote Device

Warning Messages include:

- Autopurge Failure – Purge Tank Pressure has not decreased
- Excessive Purging
- Faulty Strong Solution Temp Sensor RT3
- Generator High Pressure – Load set to 30%
- High Steam/Hot Water Supply Temperature
- High Steam Supply Temperature
- Low Refrigerant Temperature
- Possible Crystallization
- Purge Pump Failure
- Purge Pump Overloads Open
- Purge Pump Service Recommended
- Purge Tank Pressure is > 100mmHg
- Purge Transducer is out of range
- Refrigerant Level Switch Conflict
- Refrigerant Pump Overload Contact in Conflict
- Solution Pump Overload Contact in Conflict

Routine Shutdown Messages include:

- Remote Stop
- Local Stop

Cycling Shutdown Messages include:

- Daily Schedule Programmed Stop
- Emergency Power Source Activated
- Low Leaving Liquid Temperature
- Power Failure Occurred
- Unit Shutdown by Remote Device
- Unit Shutdown by Multiunit Remote

Safety Shutdown Messages include:

- Auxiliary Safety Shutdown
- Chilled Liquid Flow Switch Opened
- Cond Flow Switch closed during Limited Dilution
- Condenser Liquid Flow Switch Opened
- Dilution Cycle Interrupted – Chilled Water Off
- Dilution Cycle Interrupted – Cond Water Off
- Dilution Cycle Interrupted – Switch 3F Opened
- Generator High Pressure – Analog PT1
- Generator Hi-Temp Analog Switch RT3
- Generator Hi-Press Digital Switch HP1 Opened
- Generator Hi-Temp Digital Switch HT1 Opened
- High Concentration in Strong Solution
- High Steam/Hot Water Supply Temperature
- High Steam Supply Pressure
- Low Refrigerant Temperature Analog RT8
- Low Refrigerant Temperature Digital
- Refrigerant Pump Overloads Opened
- Refrigerant Pump Level Switch Failure
- Solution Pump Overloads Opened

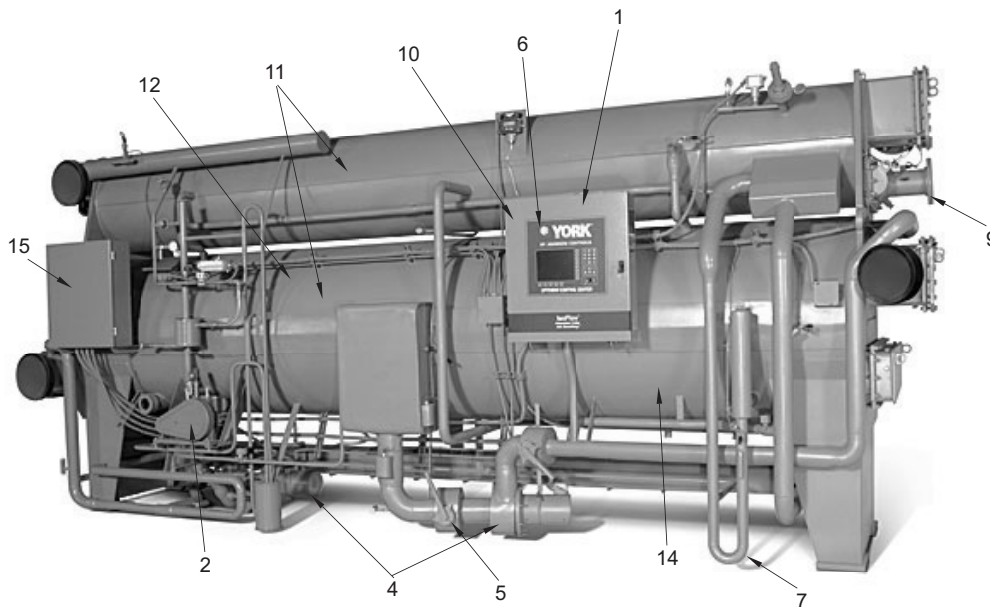

FIG. 1 – SINGLE-STAGE ABSORPTION CHILLER RELIABILITY FEATURES

The YORK OptiView w/SmartPurge **YIA** Absorption Chiller introduces a revolutionary system of unit controls and mechanical devices designed to keep the chiller running in even the most extreme circumstances. Old concerns about crystallization are approached with a hybrid of new technology and older, proven methods. Additionally, the **YIA** chiller contains a host of other features designed to give the machine a long, trouble free life.

This YORK brand absorption chiller has been in production for more than 40 years. Yorks' commitment to quality, reliability, and service after the sale is evidenced by having many absorbers that have been in operation for more than 40 years. York has a worldwide service network that allows us to provide the highest degree of technical support, even in the most remote regions of the world. The result: the smartest, safest, and most reliable single effect absorption chiller on the market today. See Fig. 1 for the location of the reliability features.

1. **Optiview Control Panel** – The OptiView control panel offers diagnostics logic for ease of trouble shooting, informs of maintenance intervals, improved heat input control valve logic to minimize fluctuations in leaving chilled water temperature, and self corrective actions if the absorber is nearing a state of crystallization, among many other features.
2. **SmartPurge™ System** – SmartPurge is a most substantial improvement to assure longevity and reduce maintenance costs. The SmartPurge not only auto-

matically purges the non-condensable gases, the SmartPurge contains and quantifies the non-condensable gas generation and warns of excessive purging, making it an early warning system for air leaks - air leaks being the number one culprit of short lived absorption machines. The SmartPurge also eliminates labor and maintenance time – since no personnel are needed to purge the unit or empty the purge tank, plus eliminates the chance of costly mistakes resulting from over-purging and under-purging associated with manual type purge systems.

3. **ADVAGuard™ 750 Corrosion Inhibitor** – is an environmentally friendly inorganic corrosion inhibitor that provides superior corrosion protection. Corrosion inhibitors promote the formation of an oxide film on the surfaces of the chiller that are in contact with LiBr solution. ADVAGuard 750 Corrosion Inhibitor creates a highly stable magnetite layer resulting in lower hydrogen generation and only an eighth of the corrosion as compared with other traditional inhibitors.
4. **Hermetic Pumps** – The **YIA**'s industrial pump provides a life of trouble-free operation with a recommended 75,000 hours between service inspections. These pumps feature self-adjusting spring loaded conical bearings that ensure concentric rotation and reduce interference. These bearings, made of carbon graphite, maintain correct bearing/journal fit at all times and ensure extended trouble free operation. The pump and motor are bolted together allowing easy and inexpensive replacement of the bearings.

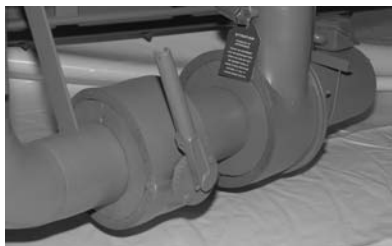

5. **Pump Isolation Valve** – Refrigerant and Solution Pump suction and discharge connections equipped with factory installed isolation valves permit quick and easy servicing of pumps.
6. **Concentration Limit** – The OptiView Control Center actually forestalls high lithium bromide concentrations that can occur during abnormal operating conditions such as rapidly decreasing cooling water temperatures at high load conditions. The panel will sense near crystallization conditions and take corrective action to prevent crystallization. If crystallization persists the panel limits heat input until the solution reaches equilibrium at a lower concentration. In this manner, the machine operates only within the safe and practical limits of the lithium bromide absorption cycle.
7. **“J” Tube** – If crystallization were to occur, it would begin in the strong solution side of the solution heat exchanger. This would force the strong solution to back up into the generator. At a certain generator solution level, the hot strong solution would overflow into the “J” tube. This tube sends hot solution directly to the absorber, immediately warming the weak solution. The heated weak solution would then warm the crystallized solution on the opposite side of the heat exchanger. This transfer of heat will cause the crystallized lithium bromide to move back into solution, allowing the unit to continue operation.
8. **Stabilizer Valve** – If minor crystallization occurs and causes overflow in the “J” tube, the temperature of the “J” tube will increase because of the hot solution. A specially placed sensor detects this change in temperature, and the panel sends a signal to open a solenoid on YORK’s patented Stabilizer Valve. When the Stabilizer Valve is open, refrigerant water is injected into the strong solution immediately before the heat exchanger. The water serves to dilute the strong solution, allowing the crystallized lithium bromide to become soluble at a lower concentration.
9. **Steam Supply Pressure/Temperature Limit** – The OptiView Control Center actually monitors the inlet steam (or hot water) temperature and steam pressure. The panel will close the control valve to the machine if temperatures or pressures become excessive, thus protecting the machine from potentially harmful conditions. To prolong the life of the control valve the control panel restricts the control valve from modulating to a less than 10% open position, thus preventing high flow velocities that could potentially cause wear and erosion of the valve gating components.
10. **Load Inhibition** – Before the **YIA** unit shuts down due to a given safety condition (see Controls section for a complete list), it first crosses a warning threshold which will cause the panel to limit heat input to the machine. In this manner, the **YIA** unit continues its vital task of making chilled water, while allowing operators the opportunity to find system deficiencies before they lead to an actual shutdown.
11. **Stainless Steel Pans** – Both the pan in the evaporator (which holds refrigerant) and the pan in the condenser (which holds refrigerant) are fabricated from stainless steel, giving the machine added protection against corrosion.
12. **Double Walled Evaporator** – The Evaporator on each **YIA** model is lined with a second wall, reducing the amount of sweating that occurs on the evaporator shell. To minimize sweating on the evaporator shell and refrigerant piping, the refrigerant insulation option must be applied.
13. **Evaporator Spray Nozzles** – Evaporator spray nozzles are made of corrosion resistant brass to ensure long life.
14. **Absorber Spray Nozzles** – Absorber spray nozzles are fabricated from stainless steel or brass, providing trouble free operation in a particularly demanding environment.
15. **Single Power Connection** – A single point power connection is all that is required for the **YIA** Absorption Chiller, providing further reliability and ease of installation.
16. **45°F (7.2°C) Condenser Water** – The **YIA** chiller is capable of operating with entering condenser water temperatures as low as 45°F (7.2°C). Without proper compensation, lower tower water temperatures cause: low refrigerant level, potential for crystallization, and low refrigerant temperature. The combination of three control systems described below allow the **YIA** to maintain a stable balance of solution and refrigerant parameters as entering tower water temperature varies:
 - At low refrigerant levels, the Unloader Control Valve opens to inject lithium bromide into the refrigerant line. This maintains refrigerant level preventing pump cavitation and keeps flow available to dilute the concentrated solution.
 - The Steam Valve Override Control System adjusts the steam input regulating the concentration of the lithium bromide leaving the generator to a safe level for the operating temperature of the machine.
 - The Stabilizer Valve will open to dilute the absorber concentration if the refrigerant temperature drops below a preset level.

The result is a system that maintains proper balance of machine loading, and solution and refrigerant characteristics to allow continuous operation with tower water.

Available Capacity at Varying Tower Water Temperature

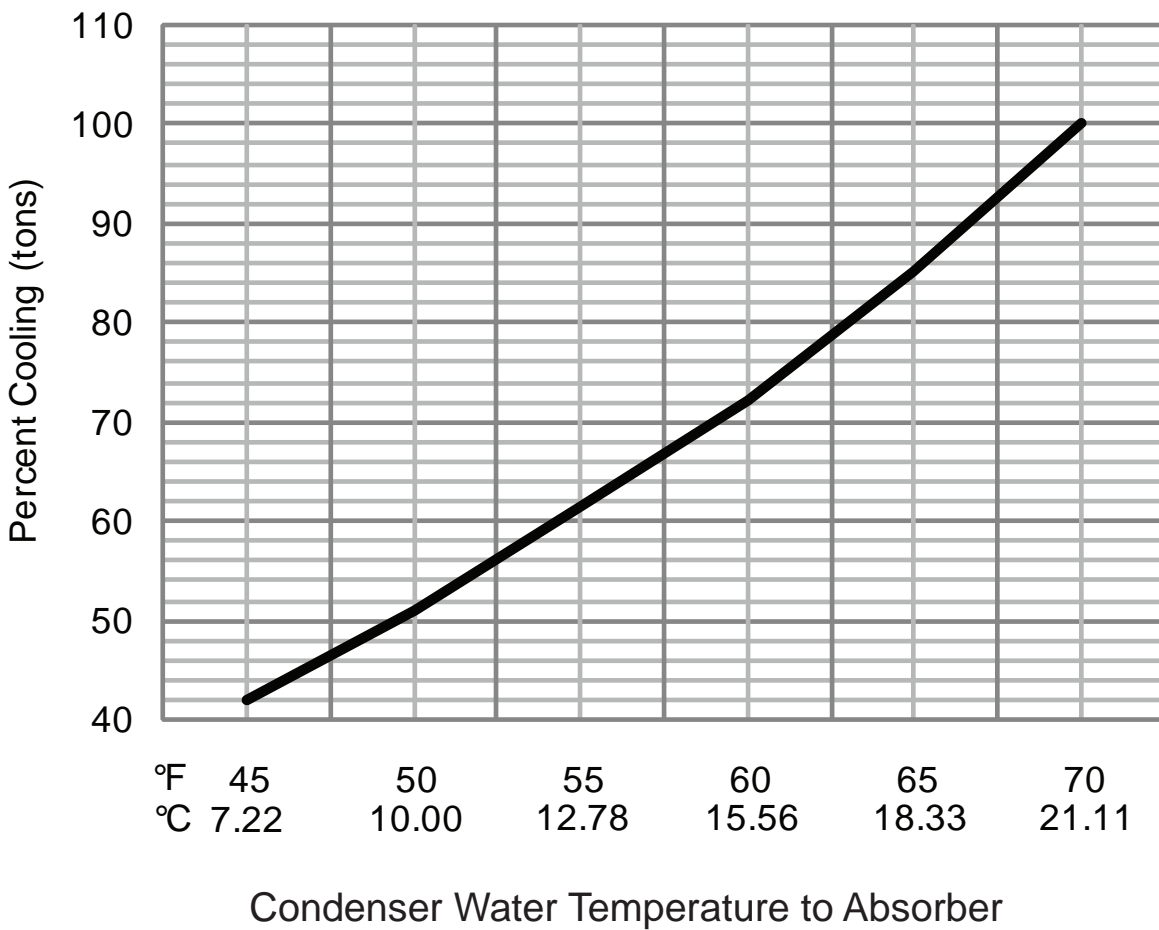

INTENTIONALLY LEFT BLANK

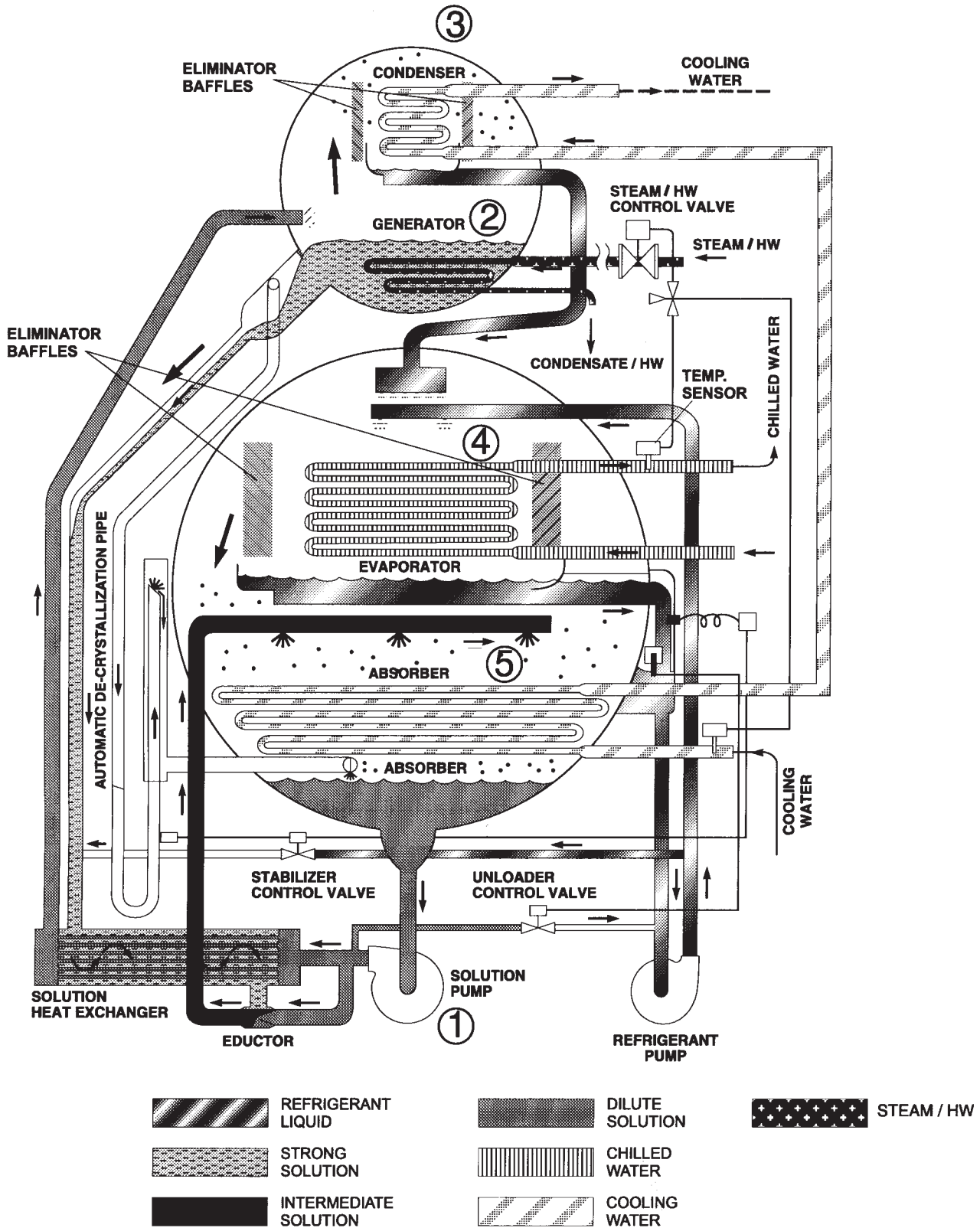
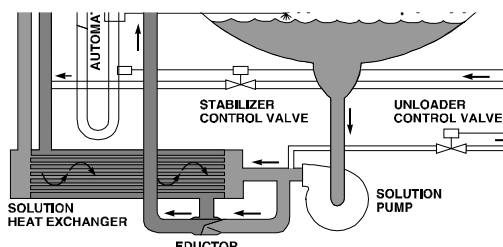

FIG. 2 – STANDARD STEAM/HOT WATER CYCLE DIAGRAM

The single effect absorption cycle uses water as the refrigerant and lithium bromide as the absorbent. It is the strong affinity that these two substances have for one another that makes the cycle work. The entire process occurs in almost a complete vacuum.

1. Solution Pump – A dilute lithium bromide solution is collected in the bottom of the absorber shell. From here, a hermetic solution pump moves the solution through a shell and tube heat exchanger for preheating.



2. Generator – After exiting the heat exchanger, the dilute solution moves into the upper shell. The solution surrounds a bundle of tubes which carries either steam or hot water. The steam or hot water transfers heat into the pool of dilute lithium bromide solution. The solution boils, sending refrigerant vapor upward into the condenser and leaving behind concentrated lithium bromide. The concentrated lithium bromide solution moves down to the heat exchanger, where it is cooled by the weak solution being pumped up to the generator.

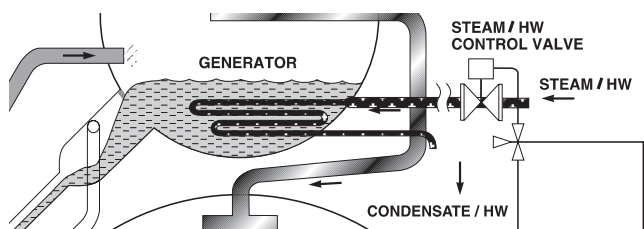

3. Condenser – The refrigerant vapor migrates through mist eliminators to the condenser tube bundle. The refrigerant vapor condenses on the tubes. The heat is removed by the cooling water which moves through the inside of the tubes. As the refrigerant condenses, it collects in a trough at the bottom of the condenser.

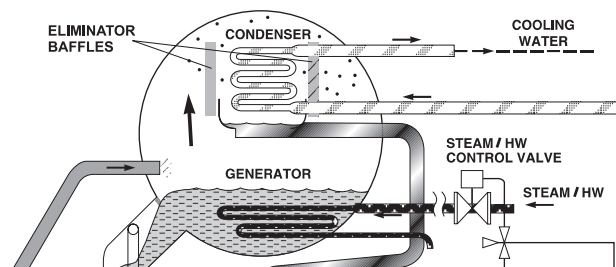

4. Evaporator – The refrigerant liquid moves from the condenser in the upper shell down to the evaporator in the lower shell and is sprayed over the evaporator tube bundle. Due to the extreme vacuum of the lower shell [6 mm Hg (0.8 kPa) absolute pressure], the refrigerant liquid boils at approximately 39°F (3.9°C), creating the refrigerant effect. (This vacuum is created by hygroscopic action - the strong affinity lithium bromide has for water - in the Absorber directly below.)

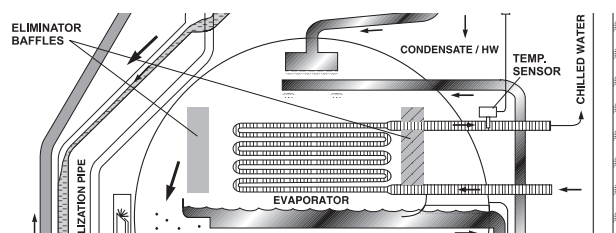

5. Absorber – As the refrigerant vapor migrates to the absorber from the evaporator, the strong lithium bromide solution from the generator is sprayed over the top of the absorber tube bundle. The strong lithium bromide solution actually pulls the refrigerant vapor into solution, creating the extreme vacuum in the evaporator. The absorption of the refrigerant vapor into the lithium bromide solution also generates heat which is removed by the cooling water. The now dilute lithium bromide solution collects in the bottom of the lower shell, where it flows down to the solution pump. The chilling cycle is now completed and the process begins once again.

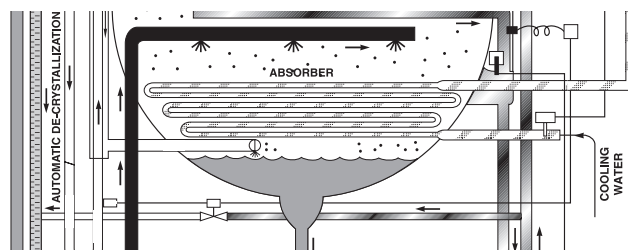

Mechanical Specifications

The mechanical features listed here apply to chillers sold in North America. Some of the features may differ on chillers delivered to other regions. Among those differences are the method of chiller shipment preparation and the types of piping interface.

The YORK **YIA** Absorption Liquid Chiller is completely factory packaged, including upper and lower shell assemblies, solution heat exchanger, hermetic solution and refrigerant pumps, microprocessor controls and all interconnecting piping and wiring.

Models **YIA** 1A1 through **YIA** 10E3 are shipped as a one piece assembly, charged with nitrogen. Models **YIA** 12F1 through **YIA** 14F3 are shipped as two pieces (upper and lower shells), each charged with nitrogen, for field reassembly. A modulating control valve shall be shipped loose for field installation. The lithium bromide fluids will be packaged and shipped just prior to the start-up of the chiller. Service personnel must notify the factory to release the fluids shipment 2 weeks prior to start-up.

SHELL ASSEMBLIES

The shell assemblies consist of a generator, condenser, evaporator and absorber housed in upper and lower shells. The shells are constructed of rolled carbon steel plate with fusion welded seams. Carbon steel tube sheets, drilled and reamed to accommodate the tubes, are welded to the end of the shells. Intermediate tube supports are fabricated of carbon steel plates. Each tube is roller expanded into the tube sheet to provide a leak tight seal and each tube is individually replaceable from either end of the unit.

The lower shell houses the low pressure section of the machine which includes the evaporator and the absorber. Both the evaporator uses $\frac{3}{4}$ " O. D. (19.1 mm), 0.025" (0.66 mm) wall and the absorber uses $\frac{3}{4}$ " O. D. (19.1 mm), 0.022" (0.56 mm) wall, copper tubing. The evaporator tubes are externally enhanced, while the absorber tubes are prime surface. The evaporator shell is double walled, enhancing unit reliability and eliminating the need for insulation over the entire shell, however in order to eliminate sweating on the shell a narrow strip of insulation is required on the longitudinal portion of the evaporator/absorber shell and insulation of the refrigerant piping as defined in the installation manual. This insulation is available as a factory installed option. Spray nozzles in the absorber are either stainless steel (models 1A1 through 6C4) or brass (models 7D1 through 14F3), while those in the evaporator are made of brass. The evaporator and absorber are separated by finned eliminator baffles designed to allow only water in the vapor state to pass to the absorber.

The upper shell contains the high pressure section of the machine, which includes the generator and the condenser.

The generator uses $\frac{3}{4}$ " O. D. (19.1 mm), 0.035" (0.89 mm) wall, 90/10 cupro-nickel tubes with external enhancements. The condenser tubes are $\frac{3}{4}$ " (19.1 mm) .022" (0.56 mm) (models 1A1, 1A2, 2B1, and 4C1), or 1" (25.4 mm) O. D., .025" (0.66 mm) (for all other models), wall prime surface copper tubing. The condenser and generator are separated by a finned eliminator which prevents liquid carryover into the condenser.

Water boxes are fabricated of carbon steel. The design working pressure is 150 PSIG (1.0 MPa)[tested at 195 PSIG (1.3 MPa)]. Integral steel water baffles are located and welded within the water box to provide the required pass arrangements. Stub out water nozzle connections grooved in accordance with ANSI/AWWA C-606 are welded to the water boxes; these nozzles are suitable for welding, flanges, or commercially available couplings, and are capped for shipment. Lifting lugs are provided on each water box, and plugged vent and drain connections are provided for each water box.

The Generator Water boxes for steam applications are designed for 150 PSIG (1.0 MPa) working pressure and are tested at 195 PSIG (1.3 MPa). The steam working pressure is limited to the specified design pressure, which, under no circumstances, is to exceed 15 PSIG (103 kPa) at the generator. The steam connections are 150 PSIG ANSI flanges. The Generator water boxes for hot water applications are designed for 300 PSIG (2.17 MPa) and tested at 390 PSIG (2.69 MPa). The hot water connections are stub-out water connections and grooved in accordance with ANSI/AWWA C-606.

SOLUTION HEAT EXCHANGER

The solution heat exchanger is a shell and tube design with carbon steel tubing. The shell is formed from carbon steel plate with fusion welded seams. Tubes are roller expanded into carbon steel tube sheets.

PUMPS

Solution and refrigerant pumps are hermetically sealed, self-lubricating, totally enclosed, factory-mounted, wired and tested. Motor windings are not exposed to LiBr or water. The suction and discharge connections for each pump are fully welded to the unit piping to minimize the opportunity for leaks. Pumps are designed to operate for a total of 75,000 hours between service inspections.

These pumps feature self-adjusting spring loaded conical bearings that ensure concentric rotation and reduce interference. These bearings, made of carbon graphite, maintain correct bearing fit at all times and ensure extended trouble free operation. They provide greater resistance to wear than ordinary journal bearings.

STABILIZER VALVE

A solenoid actuated valve sends refrigerant water into the solution heat exchanger circuit in order to combat any minor crystallization.

UNLOADER VALVE

A solenoid actuated valve sends lithium bromide solution into the refrigerant circuit, allowing the unit to operate at condenser water temperatures as low as 45°F (7.2°C).

SOLUTION AND REFRIGERANT

Each **YIA** unit is charged with lithium bromide solution containing ADVAGuard™ 750 used as a corrosion inhibitor. The refrigerant is water, and to prevent the introduction of external contaminants, a complete charge of de-ionized water is provided from the factory. A small amount of 2 ethyl, hexanol is included as a heat and mass transfer enhancer. Lithium bromide charge ships to the job site directly from YORK's vendor.

PURGE SYSTEM

The SmartPurge system automatically and continuously removes non-condensable gases from the absorber section and collects them in a cylindrical tank mounted on the outside of the upper shell. The transport of non-condensables to the purge tank is accomplished through the use of an educator along with a gas separator. This process is virtually infallible and continuous during chiller operation; the only moving part required for this process is the use of the solution pump, where a small amount of solution is taken from the discharge line to drive the educator.

The quantity of non condensable gases in the purge tank is continuously monitored by the OptiView control logic and when a specific level is reached these gases are expelled by the automatic activation of an electric motor driven vacuum pump. The rate of purge occurrence is also monitored by the OptiView panel and in the event of frequent purging a warning message is displayed on the OptiView panel.

SIGHT GLASSES

YIA units have a total of three sight glasses. One glass is located on the left front of the unit and is used for monitoring the solution level in the absorber section. Two glasses are located on the evaporator tube sheet and are used to monitor and trim the refrigerant level.

CAPACITY CONTROL

An electronically actuated control valve modulates chiller capacity from 100% to 20% of design. Valve selection is based upon pressure drop and steam/hot water flow requirements.

Steam – The valve is a cage type (for low steam mass flow) with a cast iron body or butterfly type (high steam mass flow) with a carbon steel body. Cage valves are supplied with 125 PSIG ANSI raised face flanges. Butterfly valves are wafer type valves and are supplied with 150 PSIG ANSI raised face flanges.

Hot Water – The valve is a 3 way diverting type. Valves are available in 125 PSIG, 250 PSIG, and 300 PSIG ratings. All valves are supplied with ANSI raised face flanges.

POWER PANEL

The power panel enclosure includes the following: single point wiring connection for the incoming power supply; non-fused disconnect switch; motor starters, complete with current and thermal overload protection for the solution pump, refrigerant pump, and purge pump (current overloads only); 115VAC 50/60 Hz control power transformer.

FACTORY TESTING

Each **YIA** unit is subjected to a series of rigorous leak tests, culminating in a vacuum leak test measured by a mass spectrometer and conducted while the unit is immersed in an atmosphere of low density helium. Water circuits are hydrostatically tested to 1.3 times the design working pressure.

RUPTURE DISKS

In order to ensure compliance with ASHRAE Standard 15-2001, every chiller is furnished with a Stainless Steel Rupture Disk, installed and leak tested at the factory. Rupture disks are rated at 7 ± 2 PIG and are installed on the Generator / Condenser shell.

CODES AND STANDARDS

- ARI 560 2000
- ANSI/ASHRAE 15-2001
- ANSI/ASHRAE 90.1-2001
- c/UL – Underwriters Laboratory
- NEC National Electrical Code
- CE - (Only when specified)
- OSHA Occupational Safety and Health
- PRESSURE VESSEL CODES (Only when specified – applies to the generator tube circuit only)
- ASME Boiler and Pressure Vessel Code
- TUV Pressure Vessel Code
- ISPEL Pressure Vessel Code
- PED (European Pressure Equipment Directive)

Mechanical Specifications - continued

PAINT

Exterior surfaces are protected by a single finish coat of Caribbean blue, air drying, high solids, enamel machinery paint.

SHIPMENT

The entire chiller will be shrink wrapped using a 12.0 mil thick, 5 ply, cord reinforced, UV stabilized protective covering. Water nozzles are capped prior to shipment.

Optional Features

SPECIAL TUBE MATERIALS AND WALL THICKNESSES

YIA units are designed for long life with the standard tube materials and wall thicknesses in each heat exchanger. For special applications where different tube specifications are required, YORK offers a wide array of copper and copper-nickel tubing of varying wall thicknesses. Stainless steel and titanium tube materials can be provided for extreme applications where the fluid conditions are harsh and tube life is critical.

WATERBOX AND TUBESHEET PROTECTION

Often for harsh fluid conditions, where protection considerations extend beyond the tube wall thicknesses and tube material types, specially coated water boxes and tube sheets are required. Factory applied coatings such as

WATER FLANGES

150 lb. (1.0 MPa) ANSI raised faced flanges for the evaporator and/or absorber/condenser water connection as well as the generator connection are factory welded to water nozzles. Companion flanges, bolts, nuts and gaskets are not included.

KNOCK DOWN SHIPMENT

The chiller can be shipped knocked down into two major sub assemblies (generator and main shell) as required to rig into tight spaces. This is particularly convenient for existing buildings where equipment room access does not allow rigging a factory packaged chiller. Shipment in the knock down configuration is standard on units **YIA** 12F1 through **YIA** 14F3.

REFRIGERANT SIDE INSULATION

Factory applied anti sweat insulation of flexible closed cell plastic type can be applied with vapor proof cement to the refrigerant outlet box as well as the refrigerant pump suction and discharge lines and portions of the evaporator shell that are subject to sweating.

ISOLATION PADS

Four (4) pads of 3/8" (9 mm) thick Neoprene isolation material cemented between a 3/8" (9 mm) thick steel base

plate and a 16 gauge steel cover sheet. The size is the same as the unit mounting feet (with the same mounting holes), and an approximate compressed height of 3/4" (19 mm).

HIGH PRESSURE WATER CIRCUITS

For applications with working pressures which exceed 150 PSIG (1.0 MPa), high pressure water boxes with flanges are available. These compact water boxes are rated for 300 PSIG DWP (2.1 MPa) and tested at 390 PSIG (2.7 MPa).

MARINE WATER BOXES

Marine water boxes allow service access for cleaning of the heat exchanger tubes without the need to break the water piping. Bolted-on covers are arranged for convenient access. ANSI/AWWA C-606 nozzle connections are standard; flanges are optional. Marine water boxes are available for the evaporator or absorber/condenser circuits. Marine water boxes are only available for circuits with 150 PSIG (1.0 MPa) working pressures.

INDUSTRIAL GRADE PAINT

A factory-applied coating of industrial-strength Amerlock 400 epoxy primer and Amershield finish is applied to exterior chiller surfaces for harsh environments.

WATERTIGHT ENCLOSURES AND WIRING

Chiller control and power panels are enclosed in NEMA 4 rated enclosures for industrial applications. This option includes waterproofing of control and power connection wiring.

BUILDING AUTOMATION SYSTEM INTERFACE

A communication interface permitting complete exchange of chiller data with any BAS is available with an E-Link translator. The E-Link board is easily mounted, connected and powered inside the OptiView control panel. The BAS connection is made via an RS232 or RS485 layer. Available protocols are ModBus, BacNET, N2, LON and Siemens to name a few.

Application Data

The following discussion is a guide for the application and installation of **YIA** Single-Effect Absorption Chillers to ensure reliable, trouble free life for which this equipment was designed.

LOCATION

YIA units make very little noise or vibration and may generally be located at any level in a building where the construction will support the total system operating weight.

The system location should provide sufficient space at either end of the unit to permit tube or spray header removal, if required. If a door or other large opening is conveniently located opposite one end of the system, the tubes or spray headers may be extracted and replaced through these openings. Allow sufficient clearance on the remaining sides of the unit for necessary access and maintenance.

Absorption chillers are not suitable for outdoor installation. The machine room must be enclosed, well lighted and properly ventilated to keep its temperature no higher than 104°F (40°C) and no lower than 35°F (1.7°C).

WATER CIRCUITS

Flow Rate – For normal fluid chilling duty, evaporator and absorber/condenser flow rates are permitted at water velocity levels in the heat exchangers tubes of between 3.3 ft/sec (1.00 m/s) and 12 ft/sec (3.66 m/s). Two pass units are also limited to 45 ft H₂O (134 kPA) water pressure drop. Three pass limit is 67.5 ft H₂O (201 kPA).

Under variable chilled fluid and tower fluid flow conditions, special attention needs to be paid to the rate of change of flow rate with time and the minimum/maximum velocities through the tubes. Applications involving chilled and condenser fluid flow rates which vary by more than +10% from design will require the below special considerations.

Variable Flow - through the evaporator and absorber/condenser can be applied to the YORK absorption chillers, with a couple of notes of caution:

The minimum velocity through the tubes is 3.3 fps (1.00 m/s), so systems designed for variable flow should be selected with higher velocities at design conditions.

The reduction in fluid flow rate should not exceed the reduction in load. For example, at 50% load the fluid flow rates should be 50% or greater of the design value. The leaving chilled fluid temperature should not be allowed to drop below the design value and the leaving absorber/condenser fluid temperature should not be allowed to rise above the design value.

The rate of evaporator flow change should be slow, to make sure that the chiller controls can track the building load.

Below is a rough guideline for an allowable variable evaporator flow rate of change. This may require modification based on specific application criteria.

Maximum allowable rate of change is 15 minutes to go from 100% to 50% of design flow, based on a minimum chilled fluid system turnover rate of 15 minutes. System turnover rate (STR) is a measure of the chilled fluid system volume as compared to the design chilled fluid flow rate, and is defined as:

System Turnover Rate (minutes) =

$$\frac{\text{Volume of chilled fluid system gallons (liters)}}{\text{Design chilled fluid flow rate gpm (liters per minute)}}$$

As noted above, if the STR is above 15 minutes, chilled fluid flow rate of change is 15 minutes. If STR goes below 15 minutes, chilled fluid flow rate of change must be modified as follows:

$$\text{Rate of Change from 100\% to 50\% Flow (minutes)} = 15 + 15 - \text{STR}$$

Temperature Ranges – For normal chilling duty with 100% water (no glycol), leaving chilled fluid temperatures may be selected as low as 40°F (4.4°C).

Water Quality – The practical and economical application of liquid chillers requires that the quality of the water supply for the evaporator and the absorber/condenser be analyzed by a water treatment specialist. Water quality may effect the performance of any chiller through corrosion, deposits of heat resistant scale, sedimentation or organic growth. These will hurt chiller performance and increase operation and maintenance costs. Normally, performance may be maintained by corrective water treatment and periodic cleaning of tubes. If water conditions exist which cannot be corrected by proper water treatment, it may be necessary to provide a larger allowance for fouling, and/or specify special materials of construction.

General Water Piping – All chilled water and tower water piping should be designed and installed in accordance with accepted piping practice. Chilled water and tower water pumps should be located to discharge through the **YIA** unit to assure positive pressure and flow through the unit. Piping should include offsets to provide flexibility and should be arranged to prevent drainage of water from the cooler and condenser when the pumps are shut down. Piping should be adequately supported and braced independent of the chiller to avoid imposition of strain

on chiller nozzles and components. Hangers must allow for alignment of the pipe. Isolators in the piping and in the hangers are highly desirable in achieving sound and vibration control.

Convenience Considerations – With a view to facilitating the performance of routine maintenance work, some or all of the following steps may be taken by the purchaser. Evaporator, absorber and condenser water boxes are equipped with plugged vent and drain connections. If desired, vent and drain valves may be installed with or without piping to an open drain. Pressure gauges with stop cocks, and stop valves, may be installed in the inlets and outlets of the tower and chilled water lines as close as possible to the chiller. An overhead monorail or beam hoist may be used to facilitate servicing.

Connections – The standard IsoFlow unit is designed for 150 PSIG (1.0 MPa) design working pressure in both the chilled and tower water circuits. The connections (water nozzles) to these circuits are furnished with grooves in accordance with ANSI/AWWA C-606 (ANSI flanges are optional). Piping should be arranged for ease of disassembly at the unit for performance of routine maintenance such as tube cleaning. A contractor provided crossover pipe is necessary to route the tower water from the absorber up into the condenser. All water piping should be thoroughly cleaned of all dirt and debris before final connections are made to the **YIA** unit.

Chilled Water – The chilled water circuit should be designed for constant flow. Low flow protection shall be provided by a thermal-type water flow sensor, factory mounted in the water nozzle connection and wired to the chiller control panel. A water strainer, of maximum 1/8" (3.18 mm) mesh should be field installed in the chilled water inlet line as close as possible to the chiller. If located close enough to the chiller, the chilled water pump may be protected by the same strainer. The flow sensor and strainer assure chilled water flow during unit operation. The loss or severe reduction of water flow could seriously impair the **YIA** unit performance or even result in tube freeze up.

Condenser Water – Like the chilled water circuit, the tower water circuit requires a means of proving flow. Low flow protection shall be provided by a thermal-type water flow sensor, factory mounted in the water nozzle connection and wired to the chiller control panel.

The **YIA** chiller is engineered for maximum efficiency at both design and part load operation by taking advantage of the colder cooling tower water temperatures which naturally occur in the winter months. For standard air con-

ditioning applications, **YIA** absorbers can tolerate entering tower water temperatures as low as 45°F (7°C) without a cooling tower bypass. The **YIA** unit, by a system of internal controls which regulate the solution concentration, can operate continuously and automatically with entering cooling water temperature as low as 45°F (7°C). In order to safely accept such low cooling water temperatures, the **YIA** machine actually measures solution concentration leaving the generator. If the solution concentration is too high, the OptiView Control Center will begin to close the steam valve until the concentration reaches an acceptable level. Thus, the full load capacity of the machine may decrease as the temperature of the cooling water falls. In normal air conditioning applications, this is not significant because chilling load generally decreases with lower wet bulb temperature.

For process or critical applications which have strict requirements for leaving chilled water temperatures, a three-way cooling tower bypass valve is recommended. The bypass valve should maintain entering cooling water temperature at +2.5°F (1.4°C) of the design temperature.

At the initial start up, entering tower water temperature may be as low as 45°F (7°C).

CONTROL VALVES

An automatic control valve is furnished with the unit by Johnson Controls for field mounting and wiring. The valve will be electrically actuated and will automatically close on unit shutdown. The valve should be located a distance of 5 to 10 pipe diameters from the absorption unit generator inlet flange. Cage steam valves are of a fail-close design and will close on a loss of power. Butterfly steam valves are not of a fail-close design and will not close on a loss of power, thus a condensate drain solenoid valve is factory supplied for field mounting (by others) on the generator outlet piping.

Automatic control valves are sized according to job specific full load steam or hot water parameters. For applications with low steam mass flows, the cage valve provides the best control. However, at higher mass flow, the cage valve pressure drops are prohibitively high. Thus, a butterfly valve is used. Hot water valves are three way diverting valves which bypass hot water that is not needed to maintain capacity.

SOUND AND VIBRATION CONSIDERATIONS

Since the **YIA** unit generates very little vibration, vibration eliminating mounts are not required. However, when the machine is installed where even mild noise is a problem, pads can be used.

Application Data - continued

STEAM AND CONDENSATE THEORY

Saturation Temperature

The temperature at which a fluid changes from the liquid phase to the vapor phase, or conversely, from the vapor phase to the liquid phase is called the saturation temperature. A liquid at the saturation temperature is called a saturated liquid and a vapor at the saturation temperature is called a saturated vapor. It is important to recognize that the saturation temperature of the liquid (the temperature at which the liquid will vaporize) and the saturation temperature of the vapor (the temperature at which the vapor will condense) are the same for any given pressure.

For any given pressure, the saturation temperature is the maximum temperature the liquid can achieve and stay a liquid and the minimum temperature the vapor can achieve and stay a vapor. Any attempt to raise the temperature of a liquid above the saturation temperature will only result in vaporizing some part of the liquid. Similarly, any attempt to reduce the temperature of a vapor below the saturation temperature will only result in condensing some part of the vapor.

Superheated Vapor

Vapor at any temperature above the saturation temperature corresponding to its pressure is referred to as superheated vapor. Once a liquid has been completely vaporized, the temperature of the resulting vapor can be further increased by adding energy. When the temperature of a vapor has been increased above the saturation temperature, the vapor is said to be superheated and the energy supplied to superheat the vapor is commonly referred to as superheat.

Before a vapor can be superheated, the vapor must be removed from contact with the vaporizing liquid. Also, before a superheated vapor can be condensed it must first be cooled to the saturation temperature corresponding to its pressure.

Subcooled Liquid

If, after condensation, the resulting liquid is cooled (constant pressure) so that its temperature is reduced below the saturation temperature, the liquid is said to be subcooled.

The Effect of Pressure on Saturation Temperature

The saturation temperature of a fluid depends on the pressure of the fluid. Increasing the pressure raises the saturation temperature, while reducing the pressure lowers the saturation temperature.

Condensation

Condensation of a vapor may be accomplished in several ways:

1. By extracting heat from the vapor
2. By increasing the pressure of the vapor.
3. By some combination of these two methods.

A good example of extracting heat from a vapor is in the generator section of the absorption chiller. Steam is fed to the generator through a steam modulating valve (Refer to steam valve operation for further details). As the steam flows through the generator tube bundle, heat is given up to the colder lithium bromide/water solution located on the outside of the tubes. This causes the solution to heat up and the steam to condense.

Steam Supply

Dry steam (no water droplets) or slightly superheated steam should be supplied to the unit to maximize the heat content in the steam. The steam temperature and pressure must not exceed the maximum allowable as this may cause damage to system components.

The maximum steam temperature includes any superheat. Minimal superheat can be desirable to prevent condensation in supply lines, but excess superheat must be avoided. Superheated steam must be cooled to saturation temperature before useful heat transfer can occur in the absorption chiller generator. Steam supplied to an absorber should be kept close to dry saturated steam so valuable generator heat transfer area is not used for desuperheating steam.

Steam Purity

Boiler water treatment is an essential part of any maintenance program. If the water is not properly treated, certain chemicals may exceed tolerable limits and damage the generator, control devices and adjoining piping. It is the customer's responsibility to test the condensate to make sure it is within certain limits. These limits are listed in the service manual.

If the steam carries entrained air or other gases, this will have a tendency to reduce the steam temperature. Air will also reduce the heat transfer properties of a unit because it migrates to heat transfer surfaces causing an insulating effect.

Carbon dioxide in steam is probably the most destructive form of contaminant. CO_2 (H_2CO_3) will dissolve in the condensate forming carbonic acid, which is extremely corrosive to pipes and system components.

Enthalpy

For purposes of this engineering guide, the term enthalpy (h) is the energy content contained in a certain quantity of steam or other substance. The term specific enthalpy (h) refers to the heat contained in 1 lb. (kg) of steam at certain thermodynamic conditions.

To determine the total heat content contained in a quantity of steam multiply the specific enthalpy by the mass of the steam.

To determine the approximate heat input to the **YIA** unit the following equation should be used.

$$\text{Input (Btu/hr or W/hr)} = (h1 - h2) \times m$$

Where:

- h1** = enthalpy of steam entering the unit (saturated vapor)
- h2** = enthalpy of condensate leaving the unit (subcooled liquid)
- m** = mass flow rate of steam (lb./hr or kg/hr)

h1 can be determined by reading the pressure at the Steam Inlet Pressure Indicator. Then refer to steam tables to find the enthalpy of the saturated vapor at this pressure. This value assumes that dry steam is entering the unit.

Refer to subcooled liquid tables to determine enthalpy of the condensate leaving the unit. Both temperature and pressure must be measured to determine this value.

Steam Information

Latent heat is the quantity of energy that must be removed to condense steam from a saturated vapor to a saturated liquid (at a constant pressure). Any additional heat removed will subcool the liquid. The same energy is needed to vaporize steam from a saturated liquid to saturated vapor. Any additional heat added will only superheat the steam.

Steam Quality

Steam quality is simply a mass percentage of saturated vapor to the total mass that is contained in a saturated steam sample. This percentage of vapor is referred to as the steam quality (X). A quality of .80 means that 80% of the saturated steam is in the vapor phase while 20% is in the liquid phase. The term dry steam that is often

seen is equivalent to saturated steam with a quality of 1.0 (100% vapor). It is important to note that as the quality decreases, the heat content of the steam also decreases.

Table 1 below lists two enthalpy values; saturated liquid enthalpy and the saturated vapor enthalpy. As discussed above, steam with a quality less than one (1) will have a certain percentage of liquid and vapor present in the steam. The saturated vapor enthalpy assumes dry steam, quality: X = 1. The saturated liquid enthalpy assumes pure water, quality: X = 0. The enthalpy of saturated water is much less than saturated steam. It follows that as the quality decreases, the enthalpy decreases from the saturated vapor value to the saturated liquid value. Since enthalpy is an indication of the heat in the steam, available heat is reduced if liquid water is contained in the steam.

System Design

The use of low pressure steam as a heat source for single effect absorption chillers is the most common application. Steam is utilized by the absorption unit at 15 PSIG (103 kPa) or lower. It can be used from a low pressure boiler, a waste steam source, or reduced from a high pressure boiler or district steam supply (approximately 18.3 lb. (8.3 kg) of steam per hour per ton of refrigeration).

The **YIA** Single-Effect Absorption Chiller is designed for a maximum pressure into the steam valve of 15 PSIG (103 kPa G), with a maximum steam temperature of 337°F (169°C).

The OptiView Control Center incorporates a steam demand limiting control which allows the user to slowly increase steam demand in a linear fashion for a time period up to 255 minutes (see "Controls" section). When steam demand limiting is not employed, start up steam demand is appreciably higher than the normal full load steam rate. Unrestricted start up demand is dependent upon the full load pressure drop through the valve. If full load design is based upon a relatively high pressure drop through the valve, the increases in steam demand on start up will not

TABLE 1 – ENTHALPY VALUES

Temp °F	Pressure mm Hg. Abs.	Specific Vol. (ft ³ / lbm)		Enthalpy (Btu/lbm)			
		PSIA	Liquid	Vapor	Liquid	Vapor	Latent heat
340	6098.76	117.93	0.0179	3.79	311.30	1190.80	879.50
345	6528.23	126.23	0.0179	3.57	316.55	1191.95	875.40
350	6957.23	134.53	0.0180	3.35	321.80	1193.10	871.30
360	7908.27	152.92	0.0181	2.96	332.35	1195.20	862.85

Application Data - continued

be nearly as much as if the design steam valve pressure drop is low. For a 3 PSIG (21 kPa) design steam valve pressure drop, one can expect about a 50% increase in steam demand on start up. If the design were based on a 4 PSIG (28 kPa) steam valve pressure drop, the increase in start up demand would be around 35% above normal. Likewise, a 2 PSIG (14 kPa) design pressure drop would give a start up steam demand about 75% above normal.

Piping Installation

All steam field piping should be installed in accordance with local, state and federal codes. Piping should be adequately supported and braced independent of the chiller. The support system must account for the expansion and contraction of the steam piping, avoiding the imposition of strain on chiller components.

A general steam piping diagram is laid out in Fig. 3 below. The steam supply may be either low pressure steam or high pressure steam reduced to low pressure steam. Steam piping should be designed in accordance with good engineering practice.

Both steam supply and condensate pipes must be properly sized and pitched to prevent liquid hammering. Steam supply mains should be sized in accordance with the required steam flow and acceptable pressure drop. Wherever possible, the steam supply line to the absorption unit should be taken off the main steam supply line from the top or side to minimize the possibility of condensate carry over. Additional consideration should be given to steam flow velocity, especially in those applications where noise is a factor. Generally speaking, steam velocities up to 6,000

fpm (30 m/s) will not produce an objectionable noise level.

The factory supplied steam control valve must be installed 5 to 10 pipe diameters from the generator steam inlet flange in order to minimize the pressure drop from the valve exit to the generator inlet.

Component Details

Component details described in the following section are shown in Fig. 3, "Typical Steam Piping."

Manual Block Valve – This valve is installed to allow manual shut off of the steam supply to the unit.

Desuperheater – A desuperheater must be used when the steam supply has a temperature in excess of 337°F (169°C). When encountered, this condition is generally associated with the high pressure steam supply or steam that has been reduced to 15 PSIG (103 kPaG) for use in the absorber. The steam supply to the control valve must be cooled to or below 337°F (169°C) total temperature by means of some type of desuperheater. The flow of coolant to the desuperheater should be automatically controlled to maintain a constant steam supply temperature to the absorption unit within the limits specified. Suitable automatic means should be provided to remove any condensate which may accumulate. A stop valve should be provided ahead of the desuperheater to facilitate maintenance. Test thermometer wells should be provided in the steam inlet and outlet from the desuperheater to check its operation.

Steam Strainer – The steam strainer (#50 mesh) is used to capture any impurities in the steam supply. These im-

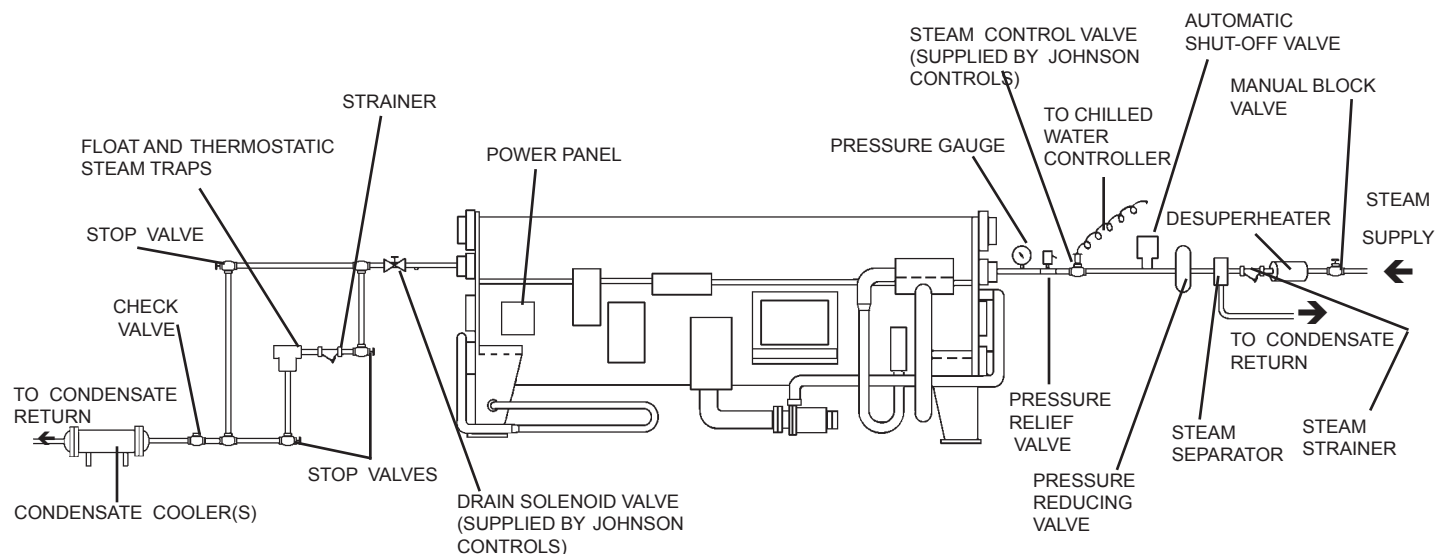

FIG. 3 – TYPICAL STEAM PIPING

purities may manifest themselves in the form of dirt, rust or precipitates. This strainer will prevent chiller system components from getting plugged. Plugged components will reduce system capacity and increase maintenance costs. A pressure gauge must be installed before and after the steam strainer. If the pressure drop as read from these two gauges increases to an unacceptable level, the strainer should be removed and cleaned.

Steam Separator – The steam separator is installed in the steam supply line and is used to separate any liquid present in the steam and assures that only dry steam enters the generator section. This condensate liquid would normally be piped through a steam trap back to the condensate tank. The steam trap will prevent any steam from blowing through the separator into the condensate return system. The use of a steam separator and trap will allow dry steam to enter the unit at all times.

The system requirement is to have dry steam into the generator of the absorption chiller. Wet steam will lessen the heating content of the steam and will affect the chiller performance. Wet steam may also cause erosion of the generator tubes and control valve components, or cause water hammer. If dry steam can be supplied without the use of a steam separator then it is not necessary to install one.

In cases where the chiller is located close to the boiler or is supplied with superheat, the steam reaching the chiller may already be dry. However, since any liquid present in the steam entering the chiller will reduce the heat input, it is important to include a steam separator unless it is truly not necessary.

Pressure Reducing Valve – A pressure reducing valve must be used if the steam pressure to the chiller is greater than 15 PSIG (103 kPaG). For applications where the steam supply pressure is known to fluctuate, it is recommended that a steam pressure regulating valve be used.

When needed, a steam pressure reducing valve suitable for dead end service must be provided in the steam supply piping ahead of the steam control valve. This pressure reducing valve should be sized on the basis of the pressure drop and absorption unit full load steam flow requirements, not on the basis of steam supply pipe size (which can result in an oversized valve). The pressure reducing valve should be provided with stop valves on both inlet and outlet and a full size bypass with a globe valve to permit manual operation during maintenance.

Two pressure reducing valves, one large and one small, piped in parallel may be desirable for those applications with continued operation at low loads or where highly variable upstream pressures exist. The smaller valve

would be set at a slightly higher pressure than the large valve so it will stay open at low flow rates while the large valve closes, thus protecting the seat of the larger valve.

The use of two steps of steam pressure reduction may be desirable on applications with pressure differentials in excess of 100 PSIG (690 kPa). The noise generated in a single step of reduction may be objectionable.

Automatic Shut-Off Valve – This valve may not be applicable to all units and is under the discretion of the customer or the customer's representative to supply and install this valve. The purpose of this valve is to assure 100% shut-off of the steam/hot water flow during a cycling/safety shutdown or a power failure. A valve that will completely shut-off steam/hot water flow to the unit during such a failure is recommended. This steam valve should be bubble tight.

Pressure Relief Valve – A 15 PSIG (103 kPaG) pressure relief valve should be installed to protect the steam generator vessel. The vessel must be protected from pressures above 15 PSIG (103 kPaG).

To prevent nuisance blowing of the relief valve, it should be set 2 or 3 PSIG (14 to 21 kPa) above the generator operating pressure and within code requirements. The relief valve should be sized for maximum steam flow and vented in accordance with local codes. A relief valve is not required if there is a properly sized relief valve elsewhere in the system, which will keep the system below 15 PSIG (103 kPaG).

Steam Control Valve (Johnson Controls Supplied) – The steam control valve as found in the ship-loose-items, should be installed as shown in Fig. 3. This valve should be connected to the appropriate wiring harness and is used to control the amount of steam that enters the unit. It will modulate from 10% to 100% depending on the leaving chilled water temperature. The minimum value of 10% is set in the field. This is explained in detail in the installation manual.

Steam Inlet Pressure Indicator (If Desired) – A pressure gauge can be installed to allow the operator to determine the inlet steam pressure to the unit. The inlet steam pressure is indicated by the micropanel, but an additional pressure gauge may be desired.

Drain Solenoid Valve (Johnson Controls Supplied) – Factory supplied device used to insure zero steam flow through the unit during shut down. This valve should be installed in a horizontal run of pipe within 2 feet (0.6 m) of the chiller condensate outlet. This valve is not supplied when a fail-close steam control valve is used.

Application Data - continued

Vacuum Breaker (If Desired) – A vacuum breaker will often not be necessary, but they can prevent condensate build up in the generator section of the chiller at part load. A discussion of the chillers operation and the function of the vacuum breaker follows:

If an atmospheric return system is used, the generator will not operate in the vacuum region, but will operate at atmospheric pressure at the low load conditions. Throttling of the steam valve at low load results in steam condensate back up into the generator tubes. As the load increases, the steam valve will open and the rising steam pressure will force the condensate out of the generator. The accumulation of condensate in the generator at reduced loads and subsequent drainage will have no adverse effect on absorption unit efficiency. However, the cyclical drainage of condensate from the unit will require that the main system condensate receiver be sized with sufficient additional capacity to accommodate this fluctuation (assumed to be equal to the absorption unit generator volume as a maximum see Table 2 on page 22).

To avoid fluctuation in condensate return or water hammer in the generator tubes, a vacuum breaker swing check valve can be added as shown in Fig. 5 on page 24. A 3/8 inch size is sufficient to prevent condensate build up. For safety, a pipe should be installed from the check valve to a location close to the floor or other safe place. The use of the check valve to permit air entrance into the generator tubes has the disadvantage that this air must later be purged through the thermostatic element of the float trap and tends to entrain air in the condensate return.

Strainer(s) – A fine mesh strainer with blow off valve should be provided ahead of the steam trap(s) to protect it from damage.

Float and Thermostatic Steam Trap(s) – Fig. 3 shows a typical condensate steam trap piping arrangement as used on an absorption unit. The trap serves the purpose of passing condensate, but preventing the loss of steam. A float and thermostatic steam trap is recommended for this application. It should be applied in accordance with the manufacturer's recommendations. The trap should be located as close to the generator condensate outlet as possible in the horizontal plane. In the vertical plane, the trap should be located below the generator condensate outlet, a minimum of 12 inches (0.3 m). Preferably, the maximum possible elevation between the generator outlet and the trap should be used.

The condensate outlet line should be sized in accordance with good engineering practice for condensate at the flash point and should be kept as short and simple as possible. Stop valves should be provided ahead of the strainer and

after the trap for necessary maintenance; and a full size bypass provided with globe valve for manual operation during maintenance. A full trap outlet line size connection and valve should be provided for blow off and test purposes.

The steam trap should be selected for about 1.5 times the design full steam flow rate, at the design operating pressure differential. The operating full load pressure differential: $PD = SP - P1 - P2 - P3$ where:

PD = Trap pressure drop, PSIG.

SP = Steam pressure, PSIG, at generator flange normally 3 PSIG less than the design pressure to the control valve.

P1 = Condensate line pressure drop losses, PSIG.

P2 = Check valve pressure drop loss, PSIG.

P3 = Condensate cooler pressure drop loss, PSIG.

Select float capacity from manufacturer's ratings per above recommendations.

The line from the steam trap to the condensate receiver will contain some flash vapor flowing with the condensate. This line should be as short as possible, preferably not more than 30 feet (9 m) in equivalent length. As a general rule, it should be sized according to the number of traps used and one or more sizes larger in the case of longer piping runs.

Check Valve – A check valve should be provided in the trap outlet line to prevent any possible air or condensate leakage back to the generator under reduced load operating conditions.

Condensate Cooler – The use of a condensate cooler between the trap and the condensate receiver to cool the condensate below its flash is required for vacuum return systems and may be desirable, though not required, for atmospheric return systems.

The variations in condensate flow must be recognized and the cooler selected to cool the maximum flow of condensate 5-10°F (3-6°C) below the saturation temperature of the lowest pressure in the system (atmospheric pressure for an atmospheric return or the lowest pressure in a vacuum return system). Sufficient coolant must be provided to cool the maximum condensate flow to the desired temperature. Coolers may be air or evaporatively cooled, providing they can produce the desired leaving condensate temperature. The flow of coolant should be automatically controlled to provide the desired leaving condensate temperature. Coolant flow could be manually set for maximum load and allowed to operate continuously at that level with no operating difficulties, but the poor economics of such an arrangement make automatic control preferable.

TABLE 2 – YIA CHILLER SHELL AND TUBE VOLUMES

MODEL YIA-ST	SHELL SIDE				TUBE SIDE							
	GEN/COND		ABS/EVAP		ABSORBER		EVAPORATOR		GENERATOR		CONDENSER	
	US GALLONS	LITERS	US GALLONS	LITERS	US GALLONS	LITERS	US GALLONS	LITERS	US GALLONS	LITERS	US GALLONS	LITERS
1A1	175	662	543	2055	45	170	32	121	14	53	16	61
1A2	211	799	653	2472	52	197	36	136	16	61	18	68
2A3	249	943	764	2892	58	220	40	151	17	64	25	95
2A4	277	1049	875	3312	64	242	45	170	19	72	28	106
2B1	361	1366	1006	3808	81	307	55	208	23	87	28	106
3B2	405	1533	1152	4361	90	341	61	231	25	95	40	151
3B3	456	1726	1298	4913	99	375	67	254	28	106	44	167
4B4	508	1923	1444	5466	108	409	73	276	30	114	48	182
4C1	587	2222	1516	5739	130	492	88	333	37	140	49	185
5C2	646	2445	1701	6439	143	541	96	363	41	155	68	257
5C3	719	2722	1899	7188	156	591	105	397	44	167	75	284
6C4	810	3066	2136	8085	171	647	115	435	49	185	82	310
7D1	904	3422	2690	10182	193	731	134	507	56	212	91	344
7D2	1004	3800	2992	11326	210	795	146	553	61	231	100	379
8D3	1130	4277	3371	12760	232	878	160	606	66	250	110	416
8E1	1264	4785	3756	14218	278	1052	192	727	82	310	141	534
9E2	1423	5386	4230	16012	306	1158	211	799	90	341	156	591
10E3	1582	5988	4705	17810	334	1264	230	871	97	367	171	647
12F1	1911	7234	5137	19445	395	1495	269	1018	124	469	204	772
13F2	2125	8044	5730	21690	431	1631	293	1109	135	511	223	844
14F3	2340	8858	6311	23889	467	1768	315	1192	145	549	242	916

Auxiliary Condensate Receiver – An auxiliary condensate receiver must be used if the main condensate receiver is located a great distance from the chiller or above the chiller. An auxiliary condensate pump is used to send condensate from the auxiliary receiver to the main condensate receiver.

The auxiliary condensate receiver should be located at floor level as close to the absorption unit as possible. A check valve in the auxiliary condensate pump discharge line is recommended where condensate backflow may occur.

Auxiliary condensate receivers with condensate pumps are available as a package. They include a float or other control to cycle the pump to suit the condensate flow. Manufacturers' recommendations concerning selection and application of these packages should be followed.

CONDENSATE RETURN SYSTEMS

Steam condensate return systems should be designed in accordance with good engineering practice for the general purpose of removing condensate from the absorp-

tion unit's generator and returning it to the boiler. Either an atmospheric or a vacuum condensate return system may be used with absorption units, as discussed earlier in this section.

A general understanding of the YORK single-effect absorption unit operating requirements and characteristics is necessary before discussing the condensate return systems. The absorption chiller will operate at full load steam pressures in the 9 12 PSIG (62 to 88 kPa) range, down to pressures well into the vacuum region at part load. As the cooling load decreases, the chilled water controller will start closing the steam control valve, reducing both steam flow and steam pressure to the generator. At some part load point, say 75% for illustration, the steam pressure will be 0 PSIG, or atmospheric. With further reduction in load, the steam valve will continue to close, resulting in generator steam pressures below atmospheric pressure (providing a vacuum condensate return system is used). If an atmospheric return system is used or if a vacuum breaker is installed at the outlet of the chiller then the generator pressure will not drop below atmospheric. The use of a vacuum breaker is discussed on page 21.

Application Data - continued

Three basic types of return systems are possible: (1) a completely atmospheric system; (2) a system that allows the chiller and steam traps to function at atmospheric pressure, but the remainder of the condensate system/boiler feed to operate in a vacuum; (3) and a system that

quires a float controlled pump to move condensate from the auxiliary receiver to the main condensate receiver in addition to the main condensate pump/boiler feed pump.

System (2) – Since the condensate will be at atmospheric

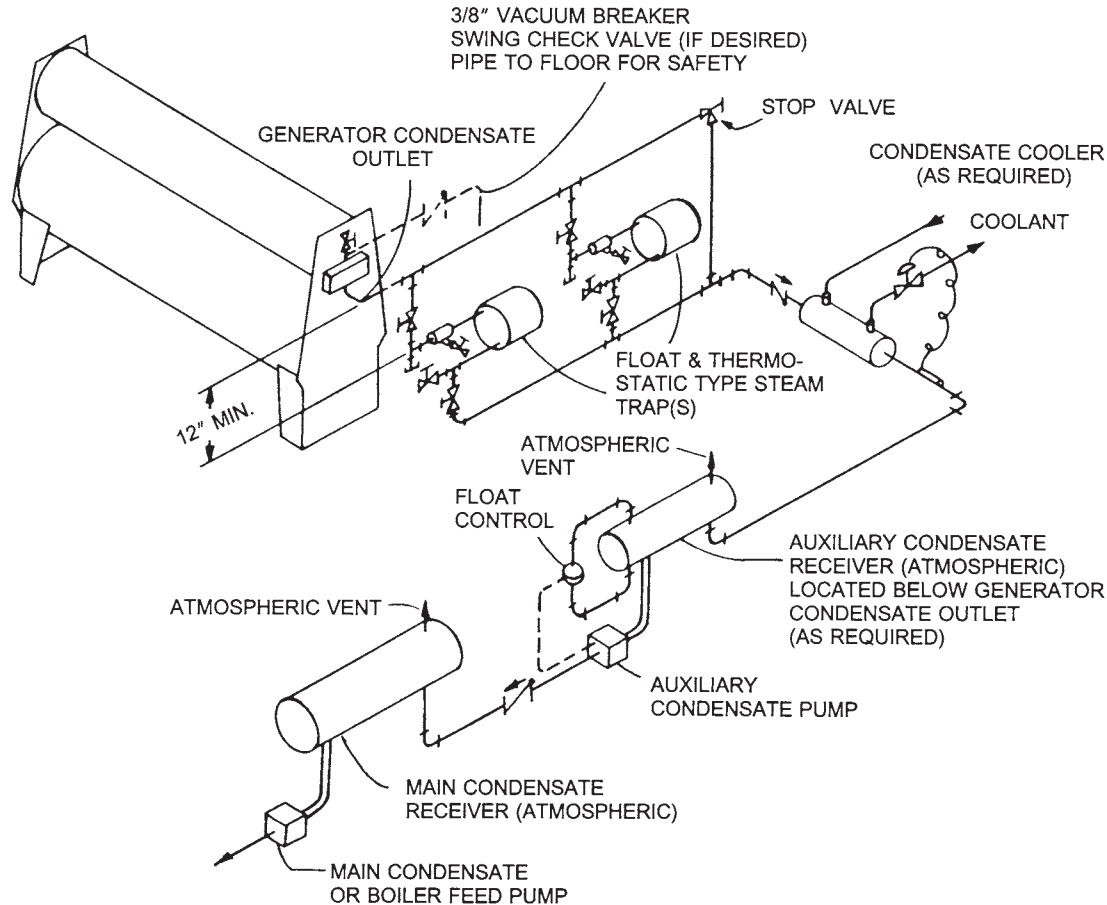

FIG. 4 – SYSTEM 1: ATMOSPHERIC CONDENSATE RETURN SYSTEM

operates entirely in a vacuum. Reference Figs. 4,5, and 6 for typical diagrams.

System (1) – For an entirely atmospheric system, a vacuum breaker may be installed at the outlet of the chiller (see page 21). Also in this system both the auxiliary condensate receiver (if needed) and the main condensate receiver must be vented to atmospheric pressure. The auxiliary condensate receiver should be used on completely atmospheric systems when the main condensate receiver is located at some distance from the condensate outlet or above the condensate outlet. This system re-

quires a float controlled pump to move condensate from the auxiliary receiver to the main condensate receiver in addition to the main condensate pump/boiler feed pump. pressure until it leaves the auxiliary condensate receiver, a vacuum breaker can still be used if desired (see previous paragraph). The auxiliary condensate receiver must be used in this system. The main condensate tank will no longer be vented to atmospheric pressure. A float control is still used in the auxiliary condensate receiver, however, it controls a valve instead of a pump. The low pressure, in the main tank, will draw the condensate through when the valve is opened.

For system (2), a condensate cooler must be provided in the line between the steam trap and the auxiliary receiver,

as detailed under condensate cooler in the component details section. It must be sized to cool the maximum flow to a temperature 5-10°F (3-6°C) below the saturation point of the vacuum return system.

A condensate cooler must be provided in the line between the steam trap and the auxiliary receiver, as detailed under condensate cooler in the component details section. It must be sized to cool the maximum flow to temperature

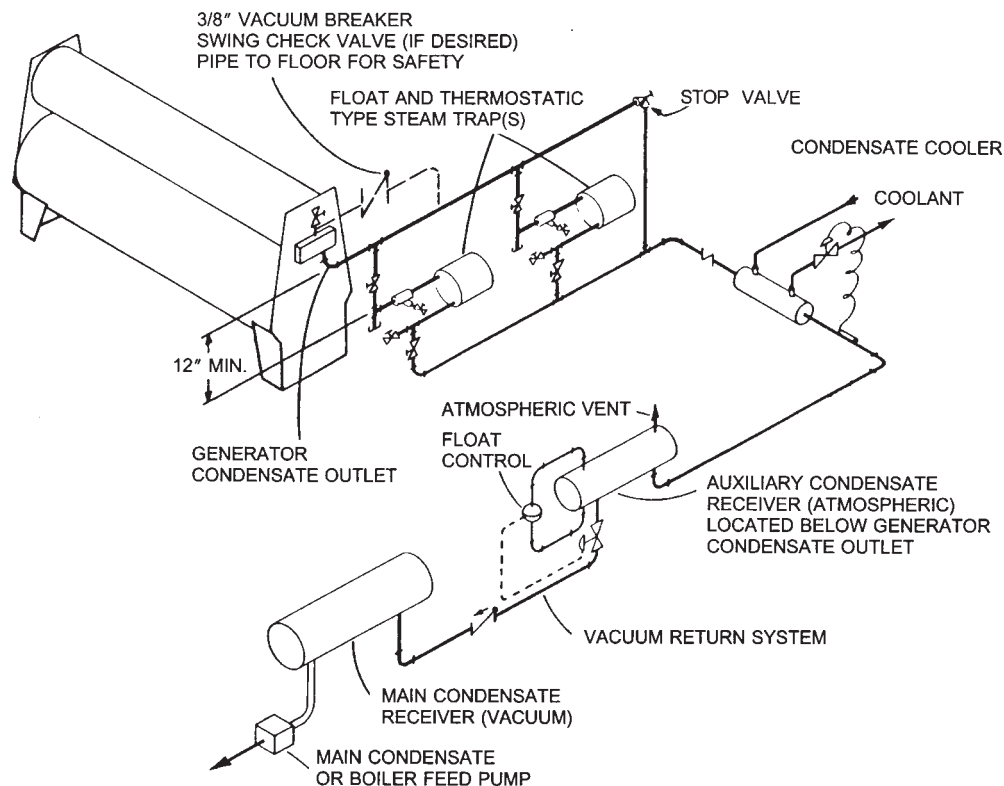

FIG. 5 – SYSTEM 2: VACUUM CONDENSATE RETURN SYSTEM

System (3) – When the low pressure steam for a YIA unit comes at or below atmospheric pressure (i.e. steam turbine exhaust), the entire system can run at a higher efficiency by using a vacuum pump on the condensate return system. At low load, when the absorption system is operating in the vacuum region, this vacuum can only be obtained if the condensate return system similarly operates in a vacuum. With a vacuum condensate return system, the steam supply can be at vacuum steam pressure, rather than at a minimum steam pressure of 0 pounds gauge (as it is limited by systems (1) and (2)). Discharging at a steam pressure in the vacuum region can improve a steam turbine's economy and efficiency.

In this system a vacuum breaker can not be used.

5-10°F (3-6°C) below the saturation point of the vacuum return system.

HOT WATER SUPPLY

A hot water supply of 266°F (130°C) will provide sufficient heat to achieve nominal ratings. Lower hot water temperatures may not achieve the nominal capacity for a given size. Your local YORK office can provide ratings for specific hot water temperatures. A sample hot water piping arrangement is shown in Fig. 7, 8, and 9 with various hot water conditions and control valve schemes. YORK recommends that shut off valves be installed in the hot water supply and return piping for serviceability. On hot water unit shutdown, the water in the generator contracts as it cools. This may form a vacuum. This can be prevented

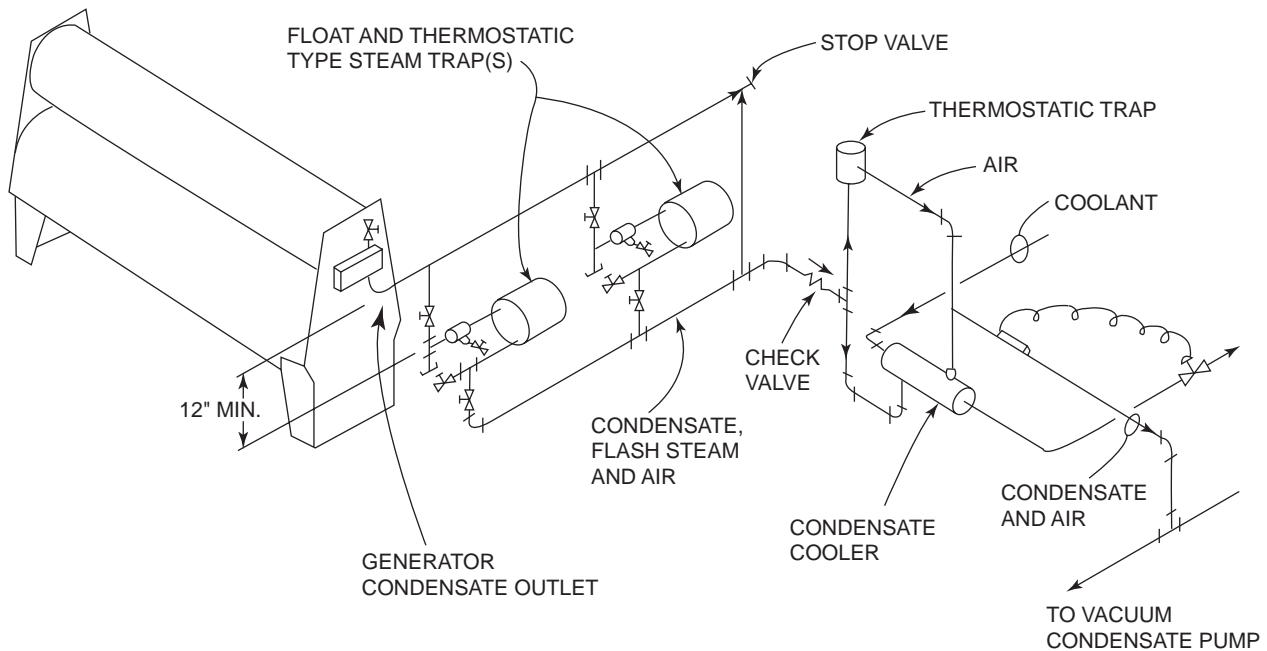

FIG.6 – SYSTEM 3: VACUUM CONDENSATE RETURN SYSTEM.

by installing a check valve in the return hot water piping with a 3/4" (19.1 mm) bypass around the check valve. It would be piped between the generator outlet and the hot water bypass. Refer to Fig. 7, 8, and 9.

INSULATION

No appreciable operation economy can be gained from the insulation of YORK **YIA** chillers. However, insulation

may be desirable to prevent sweating of cold surfaces or to prevent overheating of the mechanical equipment room due to heat gains from the high temperature surfaces of the unit. Tables 3 and 4 below give the heat loss and ventilation requirements for a 10°F ambient temperature rise for the various **YIA** units and further reduces the risk of crystallization. Tables 5 and 6 on page 32 and 33 provide approximate insulation areas.

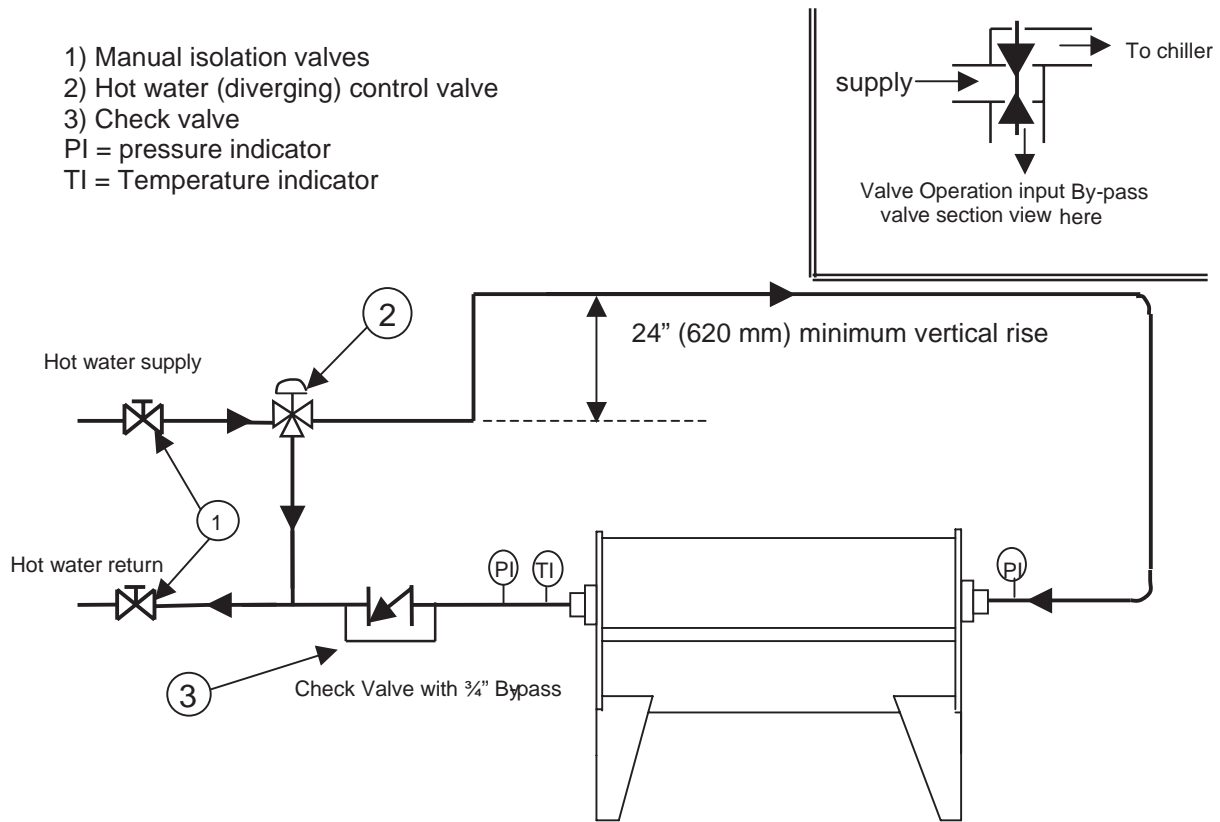

FIG. 7 – TYPICAL 3-WAY DIVERGING CONTROL VALVE ARRANGEMENT

- 1 Manual isolation valves
- 2 Hot water control valve
- 3 Check valve
- 4 By-pass valve (if required)
- PI = Pressure indicator
- TI = Temperature indicator

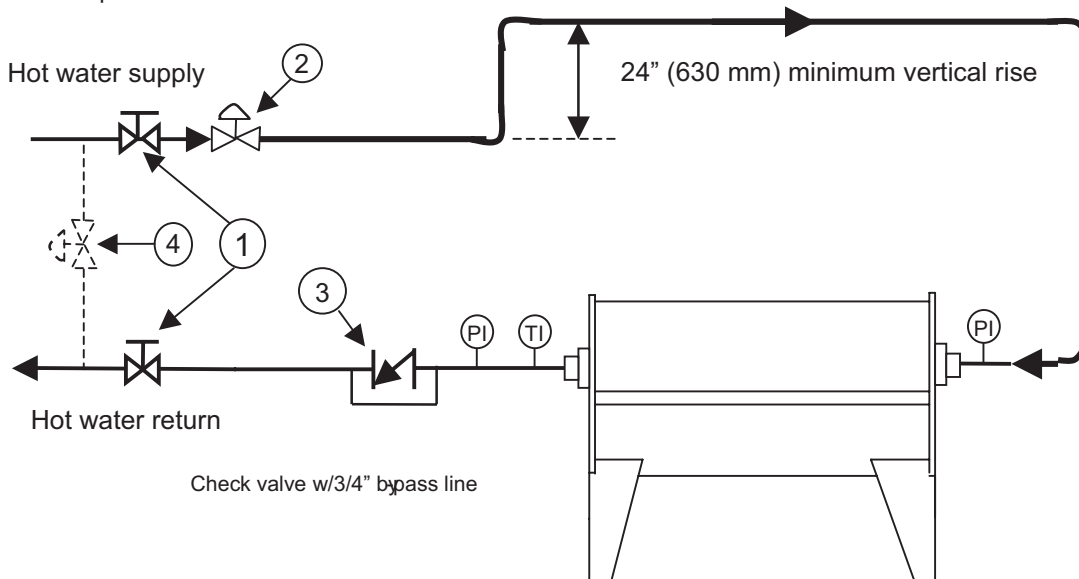

FIG.8 – TYPICAL 2-WAY CONTROL VALVE ARRANGEMENT

- 1 Manual block valves
- 2 3-way converging (mixing) valve
- 3 Check valve
- 4 Manual isolation valve
- 5 Strainer
- 6 Pump
- 7 3-way diverging (flow splitting) valve
- PI Pressure indicator
- TI Temperature Indicator

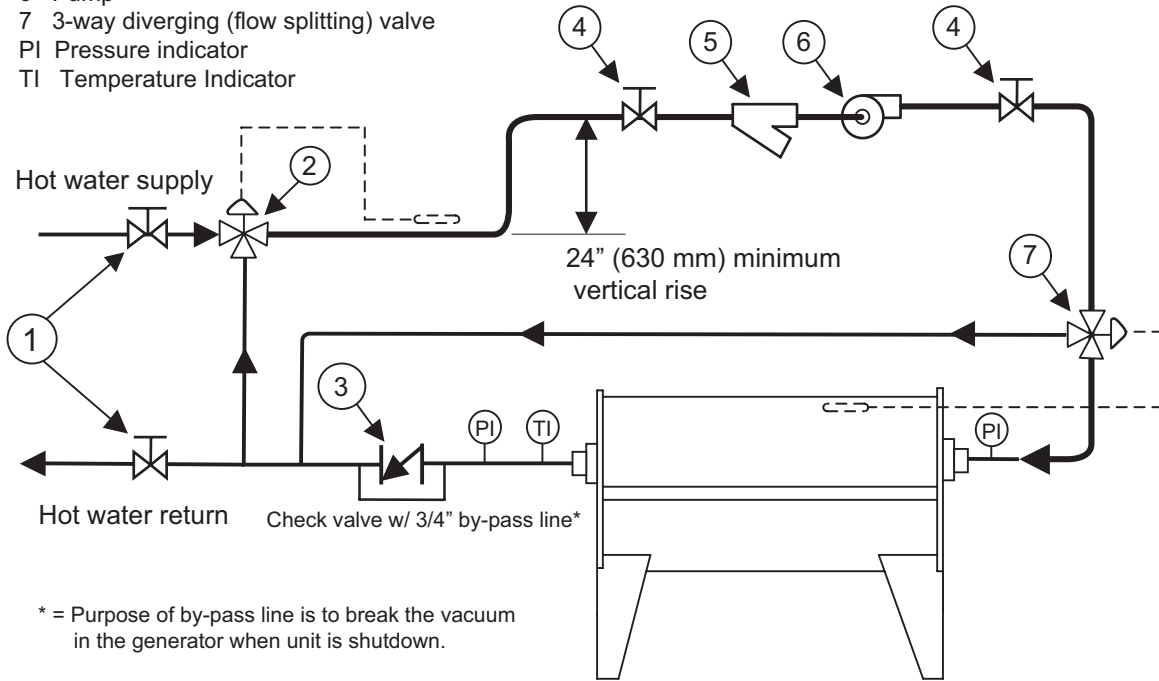

FIG. 9 – TYPICAL 3-WAY CONVERGING VALVE ARRANGEMENT (TEMPERATURE ABOVE 266°F)

TABLE 3 – GENERATOR HEAT LOSS (ENGLISH)

MODEL YIA	HEAT LOSS - BTUH	VENTILATION - CFM
1A1	7,500	750
1A2	7,500	750
2A3	8,800	880
2A4	10,000	1,000
2B1	11,000	1,100
3B2	12,500	1,250
3B3	14,000	1,400
4B4	16,000	1,600
4C1	18,000	1,800
5C2	20,000	2,000
5C3	22,000	2,200
6C4	25,000	2,500
7D1	28,000	2,800
7D2	32,000	3,200
8D3	36,000	3,600
8E1	42,000	4,200
9E2	46,000	4,600
10E3	51,000	5,100
12F1	58,000	5,800
13F2	66,000	6,600
14F3	72,000	7,200

TABLE 4 – GENERATOR HEAT LOSS (METRIC)

MODEL YIA	HEAT LOSS - BTUH	VENTILATION - CFM
1A1	7,500	750
1A2	7,500	750
2A3	8,800	880
2A4	10,000	1,000
2B1	11,000	1,100
3B2	12,500	1,250
3B3	14,000	1,400
4B4	16,000	1,600
4C1	18,000	1,800
5C2	20,000	2,000
5C3	22,000	2,200
6C4	25,000	2,500
7D1	28,000	2,800
7D2	32,000	3,200
8D3	36,000	3,600
8E1	42,000	4,200
9E2	46,000	4,600
10E3	51,000	5,100
12F1	58,000	5,800
13F2	66,000	6,600
14F3	72,000	7,200

TABLE 5 – APPROXIMATE INSULATION FOR HOT AND COLD SURFACES – ENGLISH MEASURE

MODEL YIA	COLD SURFACES			HOT SURFACES		MODEL YIA	COLD SURFACES			HOT SURFACES	
	EVAP. HEADS & END SHEETS SQ. FT.	REFRIG OUTLET BOX & PUMP SQ. FT.	SUCTION & DISCHARGE LINES – TUBULAR INSUL DIA. INCH/LIN FT.	UPPER SHELL SQ. FT.	GEN. HEADS SQ. FT.		EVAP HEADS & END SHEETS SQ. FT.	REFRIG OUTLET BOX & PUMP SQ. FT.	SUCTION & DISCHARGE LINES – TUBULAR DIA. INCH/LIN FT	UPPER SHELL SQ. FT	GEN. HEADS SQ. FT.
1A1	16	16	2/11, 4/4	70	2	6C4	26	18	2-1/2 / 14, 3/4, 4/6	185	4
1A2	16	16	2/12, 4/3	70	2	7D1	39	31	3/17, 4/6	180	7
2A3	16	16	2/12, 4/3	81	2	7D2	39	31	3/18, 4/6	200	7
2A4	16	16	2/13, 4/3	93	2	8D3	39	31	3/19, 4/6	225	7
2B1	19	17	2/9, 2-1/2 / 4, 4/4	95	3	8E1	55	43	3/22, 4/8	225	8
3B2	19	17	2/10, 2-1/2 / 4, 4/4	110	3	9E2	55	43	3/24, 4/8	255	8
3B3	19	17	2/11, 2-1/2 / 4, 4/4	125	3	10E3	55	43	3/24	285	8
4B4	19	18	2/12, 2-1/2 / 4, 4/4	136	3	12F1	67	44	3/21	290	10
4C1	26	18	2-1/2 / 11, 3/4, 4/6	132	4	13F2	67	44	3/23	320	10
5C2	26	18	2/12, 3/4, 4/6	148	4	14F3	67	44	3/24	355	10
5C3	26	18	2-1/2 / 13, 3/4, 4/6	165	4						

TABLE 6 – APPROXIMATE INSULATION FOR HOT AND COLD SURFACES – METRIC MEASURE

MODEL YIA	COLD SURFACES			HOT SURFACES		MODEL YIA	COLD SURFACES			HOT SURFACES	
	EVAP. HEADS & END SHEETS m ²	REFRIG OUTLET BOX & PUMP m ²	SUCTION & DISCHARGE LINES – TUBULAR INSUL DIA. CM/LIN. m	UPPER SHELL m ²	GEN. HEADS m ²		EVAP HEADS & END SHEETS m ²	REFRIG OUTLET BOX & PUMP m ²	SUCTION & DISCHARGE LINES – TUBULAR DIA. CM/LIN. m	UPPER SHELL m ²	GEN. HEADS m ²
1A1	1.5	1.5	5/3.4, 10/1.2	6.5	0.2	6C4	2.4	1.7	6.5/4.3, 7.5/1.2, 10/1.8	17.1	0.4
1A2	1.5	1.5	5/3.7, 10/0.9	6.5	0.2	7D1	3.6	2.9	7.5/5.2, 10/1.8	16.7	0.7
2A3	1.5	1.5	5/3.7, 10/0.9	7.5	0.2	7D2	3.6	2.9	7.5/5.5, 10/1.8	18.6	0.7
2A4	1.5	1.5	5/4.0, 10/0.9	8.6	0.2	8D3	3.6	2.9	7.5/5.8, 10/1.8	21	0.7
2B1	1.8	1.6	5/2.7, 6.5/1.2, 10/1.2	8.8	0.3	8E1	5.1	4	7.5/6.7, 10/2.4	21	0.7
3B2	1.8	1.6	5/3.0, 6.5/1.2, 10/1.2	10.2	0.3	9E2	5.1	4	7.5/7.3, 10/2.4	21	0.7
3B3	1.8	1.6	5/3.4, 6.5/1.2, 10/1.2	11.6	0.3	10E2	5.1	4	7.5/7.3	26.5	0.7
4B4	1.8	1.7	5/3.7, 6.5/1.2, 10/1.2	12.6	0.3	12F1	6.2	4.1	7.5/6.4	27	0.9
4C1	2.4	1.7	6.5/3.4, 7.5/1.2, 10/1.8	12.2	0.4	13F2	6.2	4.1	7.5/7.0	29.8	0.9
5C2	2.4	1.7	5/3.7, 7.5/1.2, 10/1.8	13.7	0.4	14F3	6.2	4.1	7.5/7.3	33	0.9
5C3	2.4	1.7	6.5/4.0, 7.5/1.2, 10/1.8	15.3	0.4						

Application Data - continued

TABLE 7 – TUBE SIDE FLUID VOLUMES

Model Size	Tube Wall Thickness	Tube Side Fluid Volumes							
		Evaporator		Absorber		Condenser		Generator	
		GPM	Liters	GPM	Liters	GPM	Liters	GPM	Liters
1A1	0.022	---	---	33.4	126.25	10.0	37.72	---	---
	0.025	32.0	121.08	---	---	---	---	---	---
	0.028	31.4	119.02	32.2	121.99	9.6	36.45	---	---
	0.035	30.2	114.26	30.9	117.12	9.2	34.99	8.0	30.45
	0.049	27.8	105.05	28.4	107.67	8.5	32.17	7.3	27.45
1A2	0.022	---	---	40.0	151.50	12.0	45.26	---	---
	0.025	38.4	145.30	---	---	---	---	---	---
	0.028	37.7	142.82	38.7	146.39	11.6	43.74	---	---
	0.035	36.2	137.12	37.1	140.54	11.1	41.99	9.7	36.54
	0.049	33.3	126.06	34.1	129.21	10.2	38.61	8.7	32.94
2A3	0.022	---	---	46.7	176.75	---	---	---	---
	0.025	44.8	169.52	---	---	19.1	72.20	---	---
	0.028	44.0	166.62	45.1	170.79	18.8	71.29	---	---
	0.035	42.3	159.97	43.3	163.97	18.3	69.19	11.3	42.63
	0.049	38.9	147.07	39.8	150.74	17.2	65.09	10.2	38.43
2A4	0.022	---	---	53.4	202.00	---	---	---	---
	0.025	51.2	193.74	---	---	21.8	82.52	---	---
	0.028	50.3	190.43	51.6	195.19	21.5	81.48	---	---
	0.035	48.3	182.82	49.5	187.39	20.9	79.08	12.9	48.71
	0.049	44.4	168.08	45.5	172.28	19.7	74.39	11.6	43.92
2B1	0.022	---	---	64.1	242.49	20.5	77.60	---	---
	0.025	60.5	228.85	---	---	---	---	---	---
	0.028	59.4	224.94	61.9	234.32	19.8	74.98	---	---
	0.035	57.1	215.96	59.4	224.96	19.0	71.99	15.0	56.61
	0.049	52.4	198.54	54.6	206.81	17.5	66.18	13.5	51.04
3B2	0.022	---	---	73.2	277.13	---	---	---	---
	0.025	69.1	261.54	---	---	31.8	120.43	---	---
	0.028	67.9	257.08	70.7	267.79	31.4	118.91	---	---
	0.035	65.2	246.81	67.9	257.09	30.5	115.41	17.1	64.70
	0.049	59.9	226.90	62.4	236.36	28.7	108.57	15.4	58.34
3B3	0.022	---	---	82.4	311.77	---	---	---	---
	0.025	77.7	294.24	---	---	35.8	135.48	---	---
	0.028	76.4	289.21	79.6	301.26	35.3	133.78	---	---
	0.035	73.4	277.66	76.4	289.23	34.3	129.84	19.2	72.79
	0.049	67.4	255.27	70.2	265.90	32.3	122.14	17.3	65.63
4B4	0.022	---	---	91.5	346.41	---	---	---	---
	0.025	86.4	326.93	---	---	39.8	150.54	---	---
	0.028	84.9	321.35	88.4	334.74	39.3	148.64	---	---
	0.035	81.5	308.51	84.9	321.37	38.1	144.27	21.4	80.87
	0.049	74.9	283.63	78.0	295.45	35.9	135.71	19.3	72.92
4C1	0.022	---	---	105.1	397.84	36.1	136.72	---	---
	0.025	99.8	377.78	---	---	---	---	---	---
	0.028	98.1	371.33	101.6	384.43	34.9	132.11	---	---
	0.035	94.2	356.50	97.5	369.07	33.5	126.83	24.3	92.10
	0.049	86.6	327.75	89.6	339.30	30.8	116.60	21.9	83.04
5C2	0.022	---	---	118.2	447.57	---	---	---	---
	0.025	112.3	425.01	---	---	55.0	208.24	---	---
	0.028	110.4	417.75	114.2	432.48	54.3	205.62	---	---
	0.035	106.0	401.07	109.7	415.21	52.7	199.57	27.4	103.61
	0.049	97.4	368.72	100.8	381.72	49.6	187.73	24.7	93.42
5C3	0.022	---	---	131.4	497.29	---	---	---	---
	0.025	124.7	472.23	---	---	61.1	231.38	---	---
	0.028	122.6	464.17	126.9	480.53	60.4	228.47	---	---
	0.035	117.7	445.63	121.9	461.34	58.6	221.74	30.4	115.13
	0.049	108.2	409.69	112.0	424.13	55.1	208.59	27.4	103.80

TABLE 7 – TUBE SIDE FLUID VOLUMES -CONT.

Tube Side Fluid Volumes									
Model Size	Tube Wall Thickness	Evaporator		Absorber		Condenser		Generator	
		GPM	Liters	GPM	Liters	GPM	Liters	GPM	Liters
6C4	0.022	---	---	147.8	559.46	---	---	---	---
	0.025	140.3	531.26	---	---	68.8	260.30	---	---
	0.028	137.9	522.19	142.8	540.60	67.9	257.03	---	---
	0.035	132.4	501.33	137.1	519.01	65.9	249.46	34.2	129.52
	0.049	121.8	460.90	126.0	477.15	62.0	234.66	30.8	116.78
7D1	0.022	---	---	161.4	611.07	---	---	---	---
	0.025	154.4	584.38	---	---	75.6	286.02	---	---
	0.028	151.7	574.41	156.0	590.48	74.6	282.42	---	---
	0.035	145.7	551.47	149.8	566.89	72.4	274.10	37.6	142.15
	0.049	133.9	506.99	137.7	521.17	68.1	257.85	33.9	128.17
7D2	0.022	---	---	179.4	678.97	---	---	---	---
	0.025	171.5	649.32	---	---	84.0	317.80	---	---
	0.028	168.6	638.23	173.3	656.08	82.9	313.80	---	---
	0.035	161.9	612.74	166.4	629.88	80.5	304.56	41.7	157.94
	0.049	148.8	563.32	153.0	579.08	75.7	286.50	37.6	142.41
8D3	0.022	---	---	201.8	763.84	---	---	---	---
	0.025	193.0	730.48	---	---	94.4	357.53	---	---
	0.028	189.7	718.01	195.0	738.09	93.3	353.02	---	---
	0.035	182.1	689.33	187.2	708.62	90.5	342.63	46.9	177.68
	0.049	167.4	633.73	172.1	651.46	85.1	322.31	42.3	160.21
8E1	0.022	---	---	232.2	879.12	---	---	---	---
	0.025	220.7	835.48	---	---	119.3	451.61	---	---
	0.028	216.9	821.22	224.4	849.49	117.8	445.92	---	---
	0.035	208.3	788.42	215.4	815.56	114.3	432.80	56.3	213.13
	0.049	191.5	724.83	198.1	749.78	107.6	407.13	50.8	192.16
9E2	0.022	---	---	261.3	989.01	---	---	---	---
	0.025	248.3	939.92	---	---	134.2	508.06	---	---
	0.028	244.1	923.87	252.5	955.67	132.5	501.66	---	---
	0.035	234.3	886.98	242.4	917.51	128.6	486.90	63.3	239.77
	0.049	215.4	815.43	222.8	843.50	121.0	458.02	57.1	216.18
10E3	0.022	---	---	290.3	1098.90	---	---	---	---
	0.025	275.9	1044.35	---	---	149.1	564.51	---	---
	0.028	271.2	1026.53	280.5	1061.86	147.3	557.41	---	---
	0.035	260.3	985.53	269.3	1019.45	142.9	540.99	70.4	266.41
	0.049	239.3	906.04	247.6	937.22	134.4	508.91	63.5	240.20
12F1	0.022	---	---	334.5	1266.14	---	---	---	---
	0.025	316.7	1198.74	---	---	175.6	664.87	---	---
	0.028	311.3	1178.27	323.2	1223.46	173.4	656.50	---	---
	0.035	298.8	1131.22	310.3	1174.60	168.3	637.17	84.8	321.12
	0.049	274.7	1039.97	285.3	1079.86	158.3	599.38	76.5	289.53
13F2	0.022	---	---	371.6	1406.82	---	---	---	---
	0.025	351.9	1331.93	---	---	195.2	738.75	---	---
	0.028	345.9	1309.19	359.1	1359.40	192.7	729.44	---	---
	0.035	332.0	1256.91	344.8	1305.11	187.0	707.97	94.3	356.80
	0.049	305.3	1155.53	317.0	1199.84	40.7	153.93	85.0	321.70
14F3	0.022	---	---	408.8	1547.50	---	---	---	---
	0.025	387.0	1465.12	---	---	214.7	812.62	---	---
	0.028	380.4	1440.11	395.0	1495.34	212.0	802.39	---	---
	0.035	365.2	1382.60	379.3	1435.62	205.7	778.77	103.7	392.48
	0.049	335.8	1271.08	348.7	1319.83	193.5	732.58	93.5	353.87

Application Data - continued

TABLE 8 – WATER BOX FLUID VOLUMES

Water Box Fluid Volumes							
Family Evaporator	Passes	Compact 150 psi		Compact 300 psi		Marine 150 psi	
		GPM	Liters	GPM	Liters	GPM	Liters
A	1	8.4	31.75	8.1	30.67	28.1	106.29
	2	6.0	22.64	5.7	21.57	28.1	90.86
	3	6.0	22.64	5.7	21.57	28.1	90.86
	4	6.0	22.64	5.7	21.57	28.1	106.29
B	1	9.8	37.00	9.4	35.74	28.1	141.47
	2	8.1	30.59	7.7	29.33	28.1	130.21
	3	8.1	30.59	7.7	29.33	28.1	130.21
	4	8.1	30.59	7.7	29.33	28.1	130.21
C	1	14.6	55.12	14.2	53.68	28.1	237.12
	2	12.3	46.38	11.9	44.94	28.1	215.35
	3	10.6	39.97	10.2	38.53	28.1	207.03
	4	10.6	39.97	10.2	38.53	28.1	207.03
D	1	21.2	80.17	20.7	78.55	28.1	390.47
	2	16.2	61.40	15.8	59.78	28.1	313.17
	3	16.2	61.40	15.8	59.78	28.1	342.03
	4	14.5	54.99	14.1	53.37	28.1	325.49
E	1	26.6	100.72	26.1	98.85	28.1	508.86
	2	23.7	89.75	23.2	87.87	28.1	481.15
	3	21.2	80.18	20.7	78.31	28.1	457.00
	4	21.2	80.18	20.7	78.31	28.1	457.00
F	1	40.6	153.64	40.0	151.48	28.1	679.91
	2	34.1	128.95	33.5	126.79	28.1	669.24
	3	30.7	116.35	30.2	114.19	28.1	650.78
Absorber							
A	1	14.1	53.31		51.53		118.74
	2	14.1	53.31		51.53		118.74
	3	14.1	53.31		51.53		118.77
B	1	21.3	80.72		78.58		181.56
	2	21.3	80.72		78.58		181.56
	3	21.3	80.72		78.58		181.56
C	1	29.9	113.32		110.88		291.79
	2	29.9	113.32		110.88		291.79
	3	29.9	113.32		110.88		291.79
D	1	37.4	141.60		138.63		392.20
	2	37.4	141.60		138.63		392.20
	3	37.4	141.60		138.63		392.20

TABLE 8 – WATER BOX FLUID VOLUMES - CONT.

Water Box Fluid Volumes							
Family Evaporator	Passes	Compact 150 psi		Compact 300 psi		Marine 150 psi	
		GPM	Liters	GPM	Liters	GPM	Liters
E	1	54.2	205.32		201.97		572.90
	2	51.3	194.34		190.99		565.10
F	1	74.5	281.96		278.16		811.30
	2	74.5	281.96		278.16		811.30
Condenser							
A	1	4.1	15.57		15.01		44.62
B		6.8	25.76		25.06		72.47
C		10.3	39.10		38.27		128.20
D		10.6	40.24		39.38		164.36
E		16.7	63.31		62.22		247.99
F		19.7	74.55		73.29		283.50
Generator							
Family	Passes	HW 300 psi		HW 362 psi		Steam (1 pass)	
		GPM	Liters	GPM	Liters	GPM	Liters
A	1	4.6	17.40	4.6	17.40	3.9	14.88
	2	4.1	15.38	4.1	15.38		
	3	4.1	15.38	4.1	15.38		
B	1	5.2	19.68	5.2	19.68	4.5	17.16
	2	4.7	17.66	4.7	17.66		
	3	4.7	17.66	4.7	17.66		
C	1	8.1	30.52	8.0	30.30	7.3	27.57
	2	7.5	28.28	7.4	28.06		
	3	7.5	28.28	7.4	28.06		
D	1	14.0	52.89	14.0	52.89	12.7	48.14
	2	12.2	46.37	12.2	46.37		
	3	12.2	46.37	12.2	46.37		
E	1	18.1	68.70	18.1	68.70	17.0	64.48
	2	17.1	64.55	17.1	64.55		
	3	17.1	64.55	17.1	64.55		
F	1	26.2	99.24	26.1	98.70	24.6	93.23
	2	24.9	94.34	24.8	93.80		
	3	24.9	94.34	24.8	93.80		

Application Data - continued

TABLE 9 – FLUID FLOW RATES LIMITS - BASED UPON STANDARD TUBES
Minimum and Maximum Flow Rates (GPM)

Model Number	Evaporator								Absorber/Condenser						Generator (HW Only)					
	1 Pass		2 Pass		3 Pass		4 Pass		1 Pass		2 Pass		3 Pass		1 Pass		2 Pass		3 Pass	
	Min	Max	Min	Max	Min	Max	Min	Max	Min	Max	Min	Max	Min	Max	Min	Max	Min	Max	Min	Max
1A1, 1A2	432	1556	216	778	144	519	108	389	667	717	334	717	222	717	161	581	81	291	54	194
2A3,2A4	432	1556	216	778	144	519	108	389	667	980	334	980	272	801	161	581	81	291	54	194
2B1	583	2101	291	1050	194	700	146	525	915	1053	458	1053	305	1053	215	775	107	387	72	259
3B2, 3B3, 4B4	583	2101	291	1050	194	700	146	525	915	1431	458	1431	397	1099	215	775	107	387	72	259
4C1	842	3034	421	1517	281	1011	210	758	1314	1626	657	1626	451	1578	304	1097	153	551	90	324
5C2, 5C3, 6C4	842	3034	421	1517	281	1011	210	758	1314	2199	657	2199	610	1578	304	1097	153	551	90	324
7D1, 7D2, 8D3	1158	4172	579	2086	386	1391	289	1043	1794	3021	897	3021	838	2155	418	1506	210	755	140	506
8E1, 9E2, 10E3	1490	5368	745	2684	497	1789	372	1342	2323	5616	1559	4186	N/A	N/A	756	2724	379	1365	253	913
12F1, 13F2, 14F3	1900	6845	950	3423	633	2282	N/A	N/A	2974	5616	1559	5358	N/A	N/A	756	2724	379	1365	253	913

Standard Mod D tubes using minimum velocity of 3.33 fps and maximum velocity of 12.00 fps

TABLE 9 – FLUID FLOW RATES LIMITS - BASED UPON STANDARD TUBES - CONT.

Model Number	Minimum and Maximum Flow Rates (Liters/second)																			
	Evaporator								Absorber/Condenser						Generator (HW Only)					
	1 Pass		2 Pass		3 Pass		4 Pass		1 Pass		2 Pass		3 Pass		1 Pass		2 Pass		3 Pass	
	Min	Max	Min	Max	Min	Max	Min	Max	Min	Max	Min	Max	Min	Max	Min	Max	Min	Max	Min	Max
1A1, 1A2	27.2	98.2	13.6	49.1	9.1	32.7	6.8	24.5	42.1	45.2	21.0	45.2	14.0	45.2	10.2	36.7	5.1	18.4	3.4	12.3
2A3,2A4	27.2	98.2	13.6	49.1	9.1	32.7	6.8	24.5	42.1	61.9	21.0	61.9	17.2	50.6	10.2	36.7	5.1	18.4	3.4	12.3
2B1	36.8	132.5	18.4	66.3	12.3	44.2	9.2	33.1	57.7	66.4	28.9	66.4	19.2	66.4	13.6	48.9	6.8	24.4	4.5	16.3
3B2, 3B3, 4B4	36.8	132.5	18.4	66.3	12.3	44.2	9.2	33.1	57.7	90.3	28.9	90.3	25.1	69.4	13.6	48.9	6.8	24.4	4.5	16.3
4C1	53.1	191.4	26.6	95.7	17.7	63.8	13.3	47.9	82.9	102.6	41.5	102.6	28.5	99.6	19.2	69.2	9.6	34.8	5.7	20.4
5C2, 5C3, 6C4	53.1	191.4	26.6	95.7	17.7	63.8	13.3	47.9	82.9	138.8	41.5	138.8	38.5	99.6	19.2	69.2	9.6	34.8	5.7	20.4
7D1, 7D2, 8D3	73.0	263.2	36.5	131.6	24.3	87.7	18.3	65.8	113.2	190.6	56.6	190.6	52.9	136.0	26.4	95.0	13.2	47.7	8.9	31.9
8E1, 9E2, 10E3	94.0	338.7	47.0	169.3	31.3	112.9	23.5	84.7	146.5	354.3	98.3	264.1	N/A	N/A	47.7	171.9	23.9	86.1	16.0	57.6
12F1, 13F2, 14F3	119.8	431.9	59.9	215.9	39.9	144.0	N/A	N/A	187.6	354.3	98.3	338.0	N/A	N/A	47.7	171.9	23.9	86.1	16.0	57.6

Standard Mod D tubes using minimum velocity of 1.015 m/s and maximum velocity of 3.658 m/s

Ratings

TABLE 10 – NOMINAL RATINGS, STEAM MACHINES – ENGLISH

MODEL YIA-ST	CAPACITY (TONS)	CONSUMPTION (LBS/HR)	EVAPORATOR					ABSORBER/CONDENSER				
			INLET (°F)	OUTLET (°F)	FLOW (GPM)	# OF PASSES	PRESSURE DROP (FT.)	INLET (°F)	OUTLET (°F)	FLOW (GPM)	# OF PASSES	PRESSURE DROP (FT.)
1A1	120	2140.2	54	44	288.0	3	14.2	85	101.2	432.0	3	14.1
1A2	155	2774.0	54	44	372.0	3	26.6	85	101.2	558.0	2	13.6
2A3	172	3084.4	54	44	412.8	2	11.7	85	101.2	620.0	2	12.5
2A4	205	3654.0	54	44	492.0	2	18.1	85	101.2	740.0	2	19.5
2B1	235	4182.0	54	44	564.0	2	11.9	85	101.2	846.0	2	17.3
3B2	273	4889.0	54	44	655.2	2	17.7	85	101.3	980.0	1	17.7
3B3	311	5518.5	54	44	746.4	2	25.0	85	101.1	1120.0	1	10.4
4B4	334	5978.3	54	44	801.6	1	4.4	85	101.2	1200.0	1	12.9
4C1	363	6488.7	54	44	871.2	2	15.2	85	101.2	1308.0	2	20.8
5C2	410	7368.2	54	44	984.0	2	21.1	85	101.3	1475.0	1	8.0
5C3	446	7942.0	54	44	1070.4	2	27.2	85	101.3	1600.0	1	10.2
6C4	518	9239.5	54	44	1243.2	2	39.9	85	101.2	1870.0	1	15.1
7D1	565	10138.4	54	44	1356.0	2	21.2	85	101.3	2030.0	2	20.6
7D2	617	11035.2	54	44	1480.8	2	27.5	85	101.2	2220.0	1	10.4
8D3	704	12608.0	54	44	1689.6	2	39.1	85	101.3	2530.0	1	14.7
8E1	794	14080.2	54	44	1905.6	2	27.5	85	101.1	2860.0	1	9.0
9E2	908	16121.9	54	44	2179.2	1	5.5	85	101.2	3270.0	2	36.1
10E3	960	17148.9	54	44	2304.0	1	6.7	85	101.3	3450.0	1	15.6
12F1	1148	20327.8	54	44	2755.2	2	38.6	85	101.1	4140.0	1	12.3
13F2	1235	21875.8	54	44	2964.0	1	6.8	85	101.1	4450.0	1	15.4
14F3	1377	24535.6	54	44	3304.8	1	9.1	85	101.2	4960.0	1	20.6

TABLE 11 – NOMINAL RATINGS, STEAM MACHINES – METRIC

MODEL YIA-ST	CAPACITY (KW)	CONSUMPTION (KG/H)	EVAPORATOR					ABSORBER/CONDENSER				
			INLET (°C)	OUTLET (°C)	FLOW (L/SEC)	# OF PASSES	PRESSURE DROP (KPA)	INLET (°C)	OUTLET (°C)	FLOW (L/SEC)	# OF PASSES	PRESSURE DROP (KPA)
1A1	420	970.8	12.2	6.7	18.17	3	42.3	29.4	38.5	27.25	3	42.1
1A2	545	1258.3	12.2	6.7	23.47	3	79.4	29.4	38.5	35.20	2	40.5
2A3	605	1399.1	12.2	6.7	26.04	2	34.8	29.4	38.5	39.11	2	37.3
2A4	721	1657.4	12.2	6.7	31.04	2	54.1	29.4	38.4	29.40	2	58.2
2B1	826	1896.9	12.2	6.7	35.58	2	35.6	29.4	38.4	53.37	2	51.7
3B2	960	2217.7	12.2	6.7	41.34	2	52.8	29.4	38.5	61.83	1	21.8
3B3	1094	2503.2	12.2	6.7	47.09	2	74.7	29.4	38.4	70.66	1	30.9
4B4	1174	2711.7	12.2	6.7	50.27	1	13.2	29.4	38.5	75.71	1	38.5
4C1	1276	2943.3	12.2	6.7	54.96	2	45.3	29.4	38.5	82.52	2	62.2
5C2	1442	3342.2	12.2	6.7	62.08	2	63.1	29.4	38.5	93.06	1	23.8
5C3	1568	3602.5	12.2	6.7	67.53	2	81.1	29.4	38.5	100.94	1	30.3
6C4	1821	4191.0	12.2	6.7	78.43	2	119.3	29.4	38.4	117.98	1	45.1
7D1	1987	4598.8	12.2	6.7	85.55	2	63.4	29.4	38.5	128.07	2	61.6
7D2	2170	5005.6	12.2	6.7	93.42	2	82.1	29.4	38.5	140.06	1	82.1
8D3	2475	5719.0	12.2	6.7	106.59	2	116.7	29.4	38.5	159.61	1	43.9
8E1	2792	6386.8	12.2	6.7	120.22	2	82.1	29.4	38.4	180.43	1	27.0
9E2	3193	7312.9	12.2	6.7	137.48	1	16.5	29.4	38.4	206.30	2	107.7
10E3	3376	7778.8	12.2	6.7	145.36	1	20.1	29.4	38.5	217.65	1	46.7
12F1	4037	9220.7	12.2	6.7	173.82	2	115.4	29.4	38.4	261.19	1	36.6
13F2	4343	9922.9	12.2	6.7	186.99	1	20.4	29.4	38.4	280.74	1	46.0
14F3	4842	11129.4	12.2	6.7	208.49	1	27.2	29.4	38.4	312.92	1	61.4

NOTES:

- All IsoFlow Chillers are rated according to ARI 560-2000. Ratings in Tables above represent unit performance at nominal conditions. For full and part load conditions at specific conditions, contact your local Johnson Controls office.

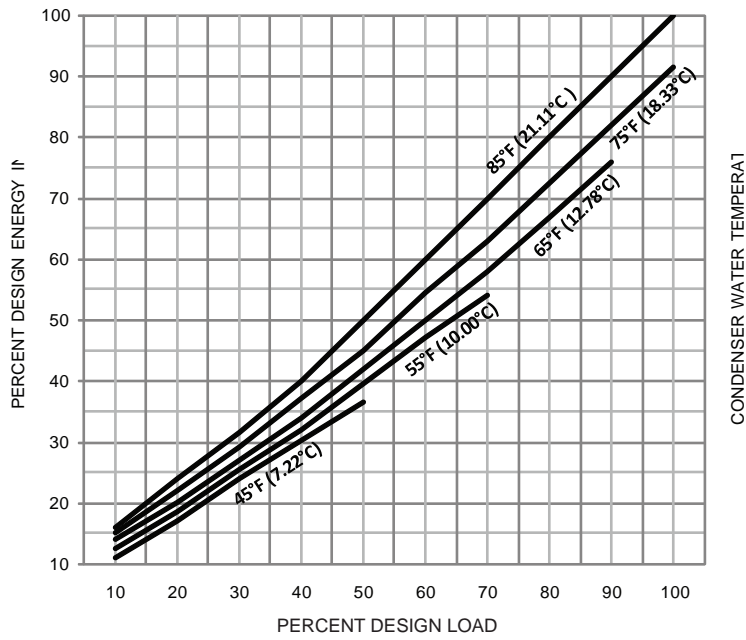

FIG. 10 – TYPICAL PART LOAD ENERGY CONSUMPTION – STANDARD UNIT

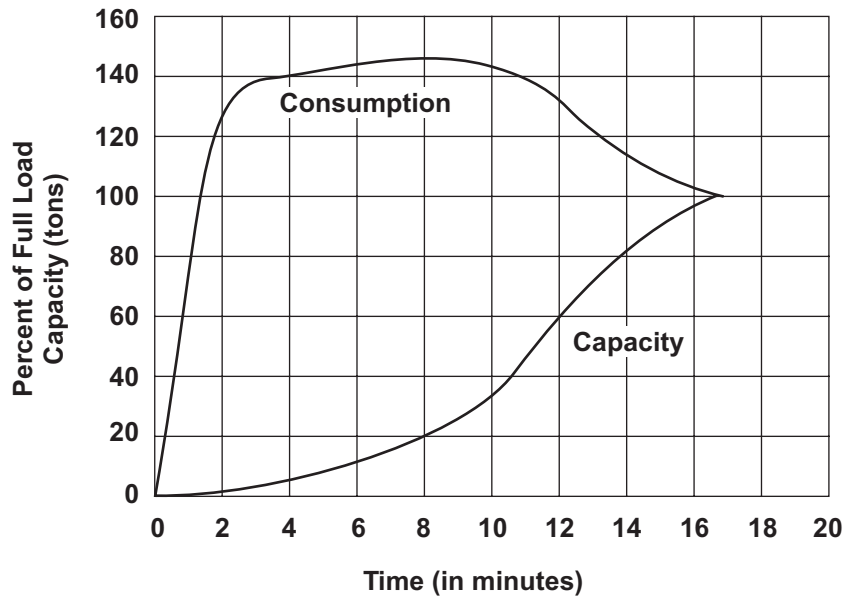

FIG. 11 – TYPICAL PART LOAD ENERGY CONSUMPTION – STANDARD UNIT

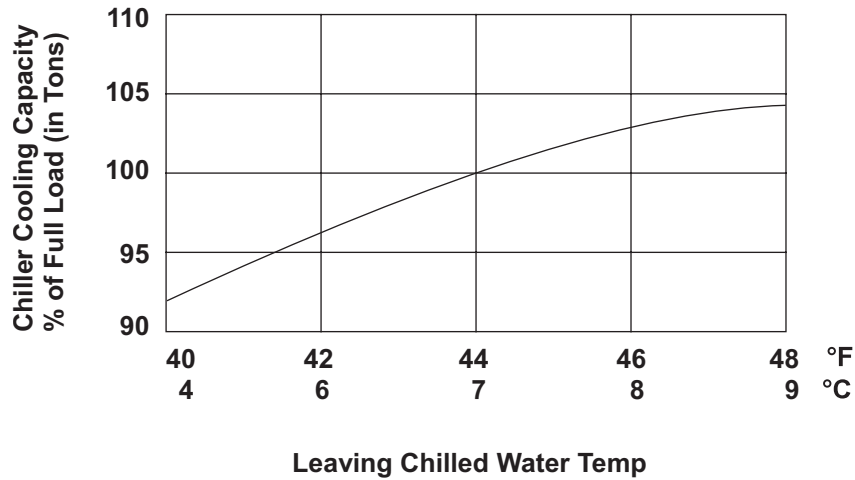

FIG. 12 – TYPICAL CHILLER COOLING CAPACITY FOR REQUIRED LCHWT

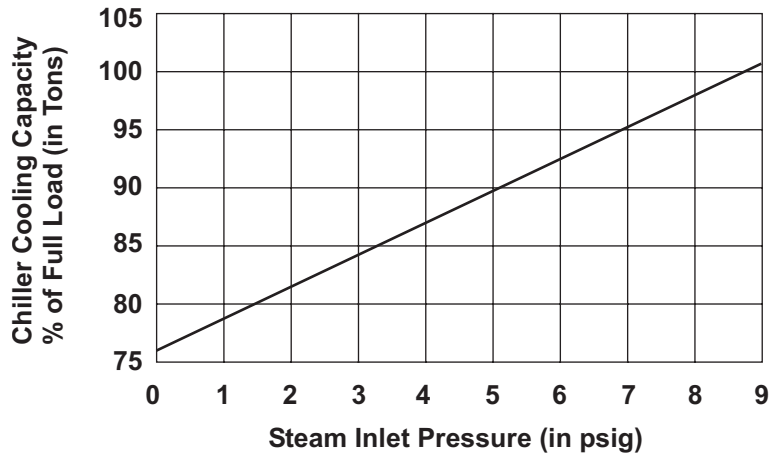

FIG. 13 – TYPICAL CHILLER COOLING CAPACITY FOR AVAILABLE STEAM INLET PRESSURE

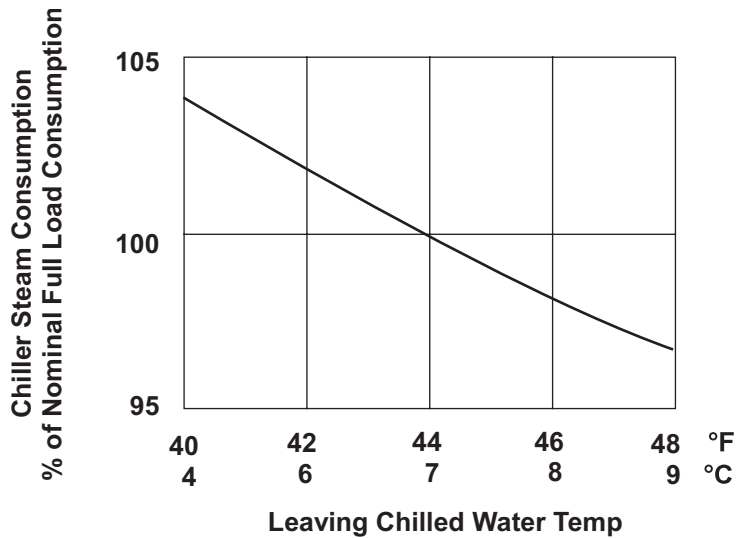

FIG. 14 – TYPICAL CHILLER STEAM CONSUMPTION FOR LCHWT

Example COP Calculation

COP for an absorption chiller is calculated with the following equation:

$$COP = \frac{Q_{output}}{Q_{input}} = \frac{Capacity \text{ (tons)} \cdot 12,000 \text{ (Btuh / ton)}}{Mass \text{ Flow} \cdot \text{Enthalpy}}$$

The example chiller has the following operating conditions:

- Capacity 1025 tons
- ECHWT/LCHWT 50°F / 40°F
- ECWT/LCWT 85°F / 97.4°F
- Steam Pressure 2.5 PSIG (dry saturated)
- Steam Flow Rate 18806.8 lbs./hr.
- Standard fouling in all circuits

From the steam tables, 2.5 PSIG (17.2 PSIGA) is:

- Steam Temperature 219.5°F
- Enthalpy of Condensate 180.5 Btu/lb.
- Enthalpy of Steam 1150.6 Btu/lb.
- Difference 970.1 Btu/lb.

$$COP = \frac{1025 \text{ tons} \cdot 12,000 \text{ (Btuh / ton)}}{18806.8 \text{ lbs./hr.} \cdot 970.1 \text{ Btu/lb.}} = 0.67$$

INTEGRATED PART LOAD VALUE (IPLV)

In the English I-P system, IPLV is calculated by the following formula:

$$IPLV \text{ or } APLV = \frac{1}{\frac{0.01}{A} + \frac{0.42}{B} + \frac{0.45}{C} + \frac{0.12}{D}}$$

- Where: A = Kw / ton at 100% Load
- B = Kw / ton at 75% Load
- C = Kw / ton at 50% Load
- D = Kw / ton at 25% Load

In SI Metric, the formula is:

$$IPLV \text{ or } APLV = 0.01A + 0.42B + 0.45C + 0.12D$$

- Where: A = COP at 100% Load
- B = COP at 75% Load
- C = COP at 50% Load
- D = COP at 25% Load

TABLE 12 – IPLV ANALYSIS

LOAD %	ENTERING CONDENSE WATER TEMP (°F)	COP	WEIGHTING FACTOR FROM ARI 560-2000	WEIGHTED AVERAGE COP
100	85.0	0.71	0.01	0.007
75	77.5	0.77	0.42	0.323
50	70.0	0.83	0.45	0.374
25	70.0	0.74	0.12	0.089

IPLV (expressed as a COP) = 0.793

TABLE 13 – FOULING FACTOR

ENGLISH I-P (ft ² °F hr/Btu)	EQUIVALENT SI METRIC (m ² °C/W)
0.00025	0.000044
0.0005	0.000088
0.00075	0.000132

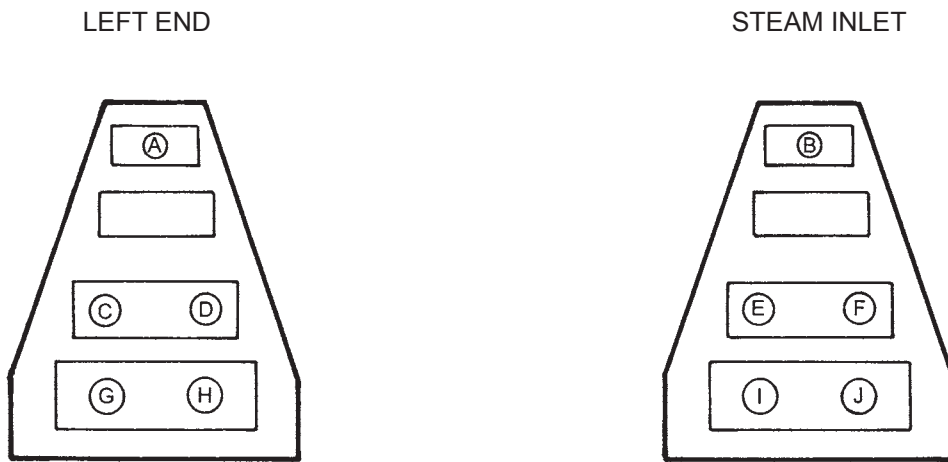

FIG. 15 – STEAM CHILLER NOZZLE ARRANGEMENTS

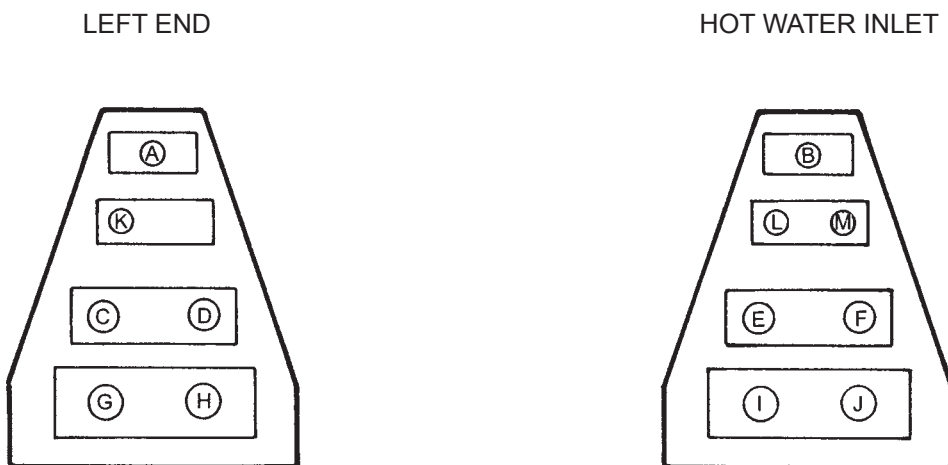

FIG. 16 – HOT WATER CHILLER NOZZLE ARRANGEMENTS

TABLE 14 – EVAPORATOR PASS ARRANGEMENTS

NUMBER PASSES	NOZZLE ARRANGEMENT	IN	OUT
1,3	E1	C	E
	E2	D	F
	E3	E	C
	E4	F	D
2,4	E5	C	D
	E6	D	C
	E7	E	F
	E8	F	E

NOTES:

1. Marine Waterboxes are available on E2, E4, E7, & E8 only.
2. 4 Pass Evaporators are not available on "F" family of chillers.

TABLE 15 – ABSORBER/CONDENSER ARRANGEMENTS

NUMBER OF ABSORBER PASSES	NOZZLE ARRANGEMENT	ABSORBER		CONDENSER	
		IN	OUT	IN	OUT
1,3	AC1	G	I	B	A
	AC2	I	G	A	B
	AC3	H	J	B	A
	AC4	J	H	A	B
2	AC5	G	H	A	B
	AC6	H	G	A	B
	AC7	I	J	B	A
	AC8	J	I	B	A

NOTES:

1. Three pass Absorber not available on "E" & "F" family chillers.
2. Marine Waterboxes not available for 1 Pass Absorber in "A" family chillers.

TABLE 16 – HOT WATER GENERATOR NOZZLE ARRANGEMENTS

NUMBER PASSES	NOZZLE ARRANGEMENT	IN	OUT
1	HW1	L	K
2	HW2	L	M
3	HW3	L	K

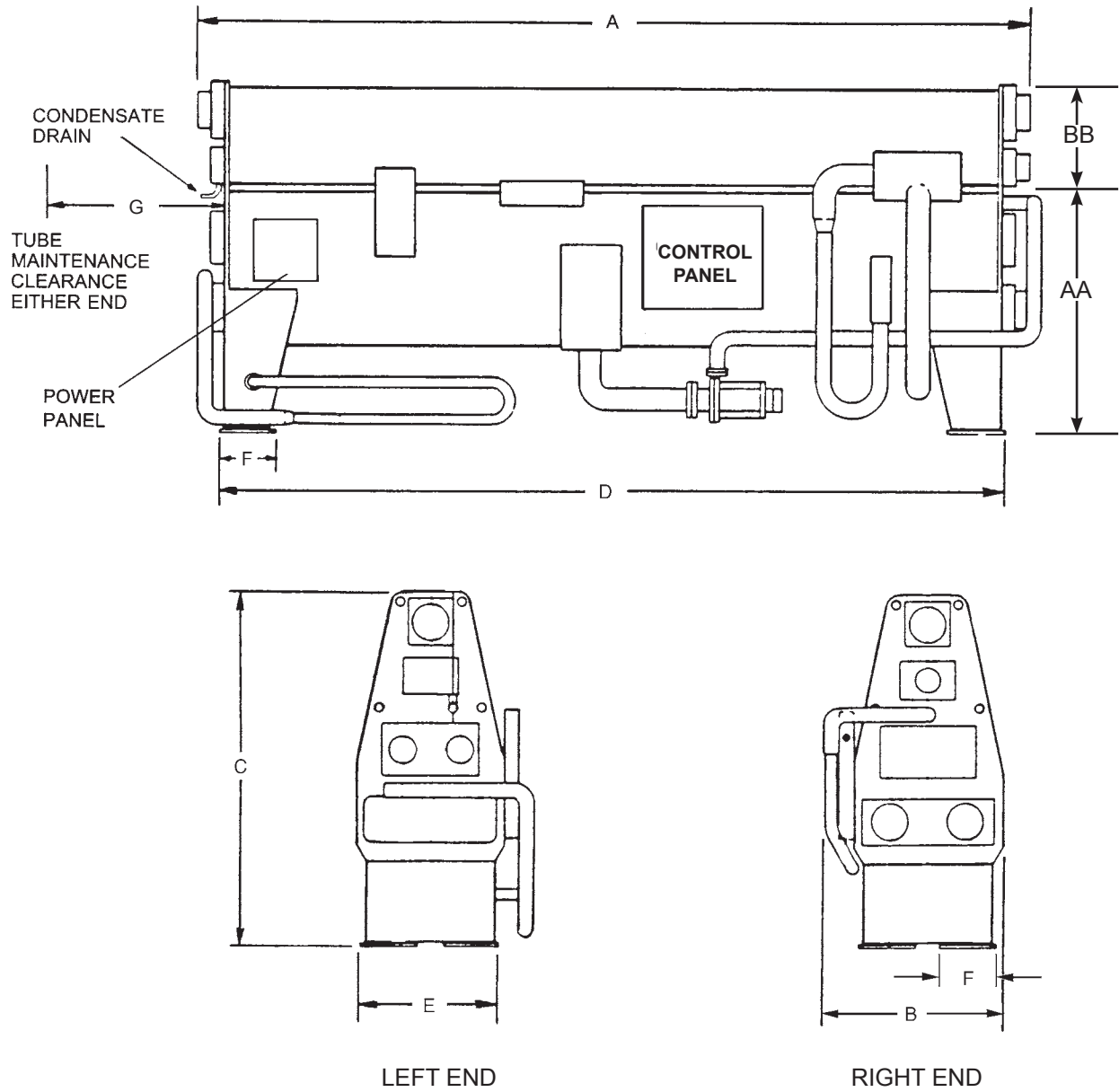

LD00688(R)

FIG. 17 – UNIT DIMENSIONS

TABLE 17 –DIMENSIONS (ENGLISH)

UNIT MODEL "YIA"	MAXIMUM OVERALL DIM.			BASE			TUBE PULL
	A	B	C	D	E	F	G
1A1	12'-2-1/2"	5'-6-1/4"	7'-7-1/4"	10'-0"	3'-2"	0'-8"	10'-8"
1A2	14'-2-1/2"	4'-5"	7'-7-1/4"	12'-0"	3'-2"	0'-8"	12'-8"
2A3	16'-2-1/2"	4'-5"	7'-7-1/4"	14'-0"	3'-2"	0'-8"	14'-8"
2A4	18'-2-1/2"	4'-5"	7'-7-1/4"	16'-0"	3'-2"	0'-8"	16'-8"
2B1	16'-2-1/2"	4'-11"	8'-7-3/4"	14'-0"	3'-7"	0'-10"	14'-8"
3B2	18'-2-1/2"	4'-11"	8'-7-3/4"	16'-0"	3'-7"	0'-10"	16'-8"
3B3	20'-2-1/2"	4'-11"	8'-7-3/4"	18'-0"	3'-7"	0'-10"	18'-8"
4B4	22'-2-1/2"	4'-11"	8'-7-3/4"	20'-0"	3'-7"	0'-10"	20'-8"
4C1	18'-2-1/2"	5'-5"	9'-10-3/4"	16'-0"	4'-2"	1'-0"	16'-8"
5C2	20'-2-1/2"	5'-5"	9'-10-3/4"	18'-0"	4'-2"	1'-0"	18'-8"
5C3	22'-2-1/2"	5'-5"	9'-10-3/4"	20'-0"	4'-2"	1'-0"	20'-8"
6C4	24'-8-1/2"	5'-5"	9'-10-3/4"	22'-6"	4'-2"	1'-0"	23'-2"
7D1	20'-2-1/2"	6'-6-1/4"	11'-7-1/4"	18'-0"	5'-2"	1'-2"	18'-8"
7D2	22'-2-1/2"	6'-6-1/4"	11'-7-1/4"	20'-0"	5'-2"	1'-2"	20'-8"
8D3	24'-8-1/2"	6'-6-1/4"	11'-7-1/4"	22'-6"	5'-2"	1'-2"	23'-2"
8E1	22'-6-1/4"	7'-2-1/4"	12'-7"	20'-0"	5'-10-1/2"	1'-4"	20'-8"
9E2	25'-0-1/4"	7'-2-1/4"	12'-7"	22'-6"	5'-10-1/2"	1'-4"	23'-2"
10E3	27'-6-1/4"	7'-2-1/4"	12'-7"	25'-0"	5'-10-1/2"	1'-4"	25'-8"
12F1	25'-0-1/4"	7'-10-1/4"	13'-10-1/2"	22'-6"	6'-4"	1'-6"	23'-2"
13F2	27'-6-1/4"	7'-10-1/4"	13'-10-1/2"	25'-0"	6'-4"	1'-6"	25'-8"
14F3	30'-6-1/4"	7'-10-1/4"	13'-10-1/2"	27'-6"	6'-4"	1'-6"	28'-2"

UNIT MODEL "YIA"	OPERATING WEIGHT LBS.	SHIPPING WEIGHT LBS.	RIGGING WEIGHT LBS.	SOLUTION WEIGHT LBS.	REFRIG. WEIGHT LBS.	WATER WEIGHT LBS.
1A1	11,424	8900	8700	1501	167	856
1A2	12,808	9800	9700	1782	250	976
2A3	14,120	10,800	10,600	1916	284	1,120
2A4	15,583	11,700	11,500	2318	317	1,248
2B1	17,896	13,400	13,300	2600	400	1,496
3B2	19,963	14,800	14,600	3002	434	1,728
3B3	21,857	16,200	16,000	3270	484	1,904
4B4	23,891	17,600	17,400	3685	534	2,072
4C1	25,185	18,500	18,200	3819	434	2,432
5C2	27,962	20,200	19,900	4502	475	2,784
5C3	30,300	21,800	21,500	4918	542	3,040
6C4	33,080	23,500	23,200	5601	642	3,336
7D1	38,827	28,700	28,400	5601	734	3,792
7D2	43,446	32,200	31,900	6285	826	4,136
8D3	48,138	35,700	35,400	6968	926	4,544
8E1	54,223	39,000	38,600	8603	1,076	5,544
9E2	60,976	43,400	43,000	10,238	1,235	6,104
10E3	67,210	48,500	48,100	10,653	1,401	6,656
12F1	76,675	55,100	44,400	12,288	1,351	7,936
13F2	83,646	59,700	48,100	13,789	1,502	8,656
14F3	90,030	63,700	50,600	15,276	1,702	9,352

NOTES:

- Units in "F" family are rigged in two pieces, as a standard.
- Operating weight = shipping weight + Weight of refrigerant and solution + weight of chilled, tower and hot water in the tubes.

Physical Data - continued

TABLE 17 – DIMENSIONS (SI) - CONT.

UNIT MODEL "YIA"	MAXIMUM OVERALL DIM.			BASE			TUBE PULL
	A	B	C	D	E	F	G
1A1	3740	1680	2340	3050	970	205	3250
1A2	4350	1350	2340	3660	970	205	3860
2A3	4,960	1350	2340	4,270	970	205	4470
2A4	5,570	1350	2340	4,880	970	205	5080
2B1	4,960	1500	2650	4,270	1100	255	4470
3B2	5,570	1500	2650	4,880	1100	255	5080
3B3	6,180	1500	2650	5,490	1100	255	5690
4B4	6,790	1500	2650	6,100	1100	255	6300
4C1	5,570	1660	3030	4,880	1270	305	5080
5C2	6,180	1660	3030	5,490	1270	305	5690
5C3	6,790	1660	3030	6,100	1270	305	6300
6C4	7,550	1660	3030	6,860	1270	305	7060
7D1	6,180	1990	3560	5,490	1580	360	5690
7D2	6,790	1990	3560	6,100	1580	360	6300
8D3	7,550	1990	3560	6,860	1580	360	7060
8E1	6,890	2190	3,840	6,100	1800	410	6300
9E2	7,650	2,190	3,840	6,860	1800	410	7060
10E3	8,410	2,190	3,840	7,620	1800	410	7830
12F1	7,650	2,400	4,250	6,860	1930	460	7060
13F2	8,410	2,400	4,250	7,620	1930	460	7830
14F3	9,310	2,400	4,250	8,390	1930	460	8590

UNIT MODEL "YIA"	OPERATING WEIGHT KGS.	SHIPPING WEIGHT KGS.	RIGGING WEIGHT KGS.	SOLUTION WEIGHT KGS.	REFRIG. WEIGHT KGS.	WATER WEIGHT KGS.
1A1	5182	4037	3946	681	76	388
1A2	5810	4445	4400	808	113	443
2A3	6,405	4899	4808	869	129	508
2A4	7,068	5307	5216	1,051	144	566
2B1	8,117	6078	6033	1,179	181	679
3B2	9,055	6713	6622	1,362	197	784
3B3	9,914	7348	7257	1,483	220	864
4B4	10,837	7983	7893	1,671	242	940
4C1	11,424	8391	8255	1,732	197	1103
5C2	12,683	9163	9026	2,042	215	1263
5C3	13,744	9888	9752	2,231	246	1379
6C4	15,005	10659	10523	2,541	291	1513
7D1	17,612	13018	12882	2,541	333	1720
7D2	19,707	14606	14470	2,851	375	1876
8D3	21,835	16193	16057	3,161	420	2061
8E1	24,595	17690	17,509	3,902	488	2515
9E2	27,658	19,686	19,504	4,644	560	2769
10E3	30,486	21,999	21,818	4,832	635	3019
12F1	34,779	24,993	20,140	5,574	613	3600
13F2	37,941	27,079	21,818	6,255	681	3926
14F3	40,837	28,894	22,952	6,929	772	4242

NOTES:

- Units in "F" family are rigged in two pieces, as a standard.
- Operating weight = shipping weight + Weight of refrigerant and solution + weight of chilled, tower and hot water in the tubes.

TABLE 18 – ELECTRICAL RATINGS

Chiller Model	Voltage (Volts-Ph-Hz)	Solution Pump		Refrigerant Pump		Purge Pump		Minimum Circuit Ampacity	Disconnect Switch (Customer supplied)	Max-Dual Elem. Fuse (Customer supplied)	Total KW
		FLA	LRA	FLA	LRA	FLA	LRA				
1A1	200/208-3-60	12.5	51	12.5	51	2.1	14.2	35.2	60	45	5.9
	230-3-60	12	55	12	55	2.2	12.8	33.5	60	45	5.9
	380-3-50	6.5	23	6.5	23	1.1	5.4	18.3	30	20	5.9
	400-3-50	6.3	25	6.3	24.5	1.1	5.1	17.7	30	20	5.9
	460-3-60	6	28	6	27.5	1.1	6.2	16.8	30	20	5.9
	575-3-60	4.9	24	4.9	24	1	4.9	13.7	30	15	5.9
1A2	200/208-3-60	12.5	51	12.5	51	2.1	14.2	35.2	60	45	5.9
	230-3-60	12	55	12	55	2.2	12.8	33.5	60	45	5.9
	380-3-50	6.5	23	6.5	23	1.1	5.4	18.3	30	20	5.9
	400-3-50	6.3	25	6.3	24.5	1.1	5.1	17.7	30	20	5.9
	460-3-60	6	28	6	27.5	1.1	6.2	16.8	30	20	5.9
	575-3-60	4.9	24	4.9	24	1	4.9	13.7	30	15	5.9
2A3	200/208-3-60	12.5	51	12.5	51	2.1	14.2	35.2	60	45	5.9
	230-3-60	12	55	12	55	2.2	12.8	33.5	60	45	5.9
	380-3-50	6.5	23	6.5	23	1.1	5.4	18.3	30	20	5.9
	400-3-50	6	25	6.3	24.5	1.1	5.1	17.7	30	20	5.9
	460-3-60	6	28	6	27.5	1.1	6.2	16.8	30	20	5.9
	575-3-60	5	24	4.9	24	1	4.9	13.7	30	15	5.9
2A4	200/208-3-60	13	51	12.5	51	2.1	14.2	35.2	60	45	5.9
	230-3-60	12	55	12	55	2.2	11.2	33.5	60	45	5.9
	380-3-50	7	23	6.5	23	1.1	5.4	18.3	30	20	5.9
	400-3-50	6.3	24.5	6.3	24.5	1.1	5.1	17.7	30	20	5.9
	460-3-60	6	27.5	6	27.5	1.1	6.2	16.8	30	20	5.9
	575-3-60	4.9	24	4.9	24	1	4.9	13.7	30	15	5.9
2B1	200/208-3-60	12.5	51	12.5	51	2.1	14.2	35.2	60	45	5.9
	230-3-60	12	55	12	55	2.2	12.8	33.5	60	45	5.9
	380-3-50	6.5	23	6.5	23	1.1	5.4	18.3	30	20	5.9
	400-3-50	6.3	24.5	6.3	24.5	1.1	5.1	17.7	30	20	5.9
	460-3-60	6	27.5	6	27.5	1.1	6.2	16.8	30	20	5.9
	575-3-60	4.9	24	4.9	24	1	4.9	13.7	30	15	5.9
3B2	200/208-3-60	20	78	12.5	51	2.1	14.2	44.6	60	60	7.3
	230-3-60	19	80	12	55	2.2	12.8	42.3	60	60	7.3
	380-3-50	6.5	23	6.5	23	1.1	5.4	18.3	30	20	7.3
	400-3-50	6.3	24.5	6.3	24.5	1.1	5.1	17.7	30	20	7.3
	460-3-60	9.5	40	6	27.5	1.1	6.2	21.2	30	30	7.3
	575-3-60	7.8	33	4.9	24	1	4.9	17.4	30	25	7.3
3B3	200/208-3-60	20	78	12.5	51	2.1	14.2	44.6	60	60	7.3
	230-3-60	19	80	12	55	2.2	12.8	42.3	60	60	7.3
	380-3-50	9.5	38	6.5	23	1.1	5.4	22.1	30	30	7.3
	400-3-50	10.4	39	6.3	24.5	1.1	5.1	22.9	30	30	7.3
	460-3-60	9.5	40	6	27.5	1.1	6.2	21.2	30	30	7.3
	575-3-60	7.8	33	4.9	24	1	4.9	17.4	30	25	7.3
4B4	200/208-3-60	20	78	12.5	51	2.1	14.2	44.6	60	60	7.3
	230-3-60	19	80	12	55	2.2	12.8	42.3	60	60	7.3
	380-3-50	9.5	38	6.5	23	1.1	5.4	22.1	30	30	7.3
	400-3-50	10.4	39	6.3	24.5	1.1	5.1	22.9	30	30	7.3
	460-3-60	9.5	40	6	27.5	1.1	6.2	21.2	30	30	7.3
	575-3-60	7.8	33	4.9	24	1	4.9	17.4	30	25	7.3
4C1	200/208-3-60	20	78	12.5	51	2.1	14.2	44.6	60	60	7.3
	230-3-60	19	80	12	55	2.2	12.8	42.3	60	60	7.3
	380-3-50	9.5	38	6.5	23	1.1	5.4	22.1	30	30	7.3
	400-3-50	10.4	39	6.3	24.5	1.1	5.1	22.9	30	30	7.3
	460-3-60	9.5	40	6	27.5	1.1	6.2	21.2	30	30	7.3
	575-3-60	7.8	33	4.9	24	1	4.9	17.4	30	25	7.3
5C2	200/208-3-60	20	78	12.5	51	2.1	14.2	44.6	60	60	7.3
	230-3-60	19	80	12	55	2.2	12.8	42.3	60	60	7.3
	380-3-50	11	40	6.5	23	1.1	5.4	24	30	30	7.3
	400-3-50	10.7	42	6.3	24.5	1.1	5.1	23.2	30	30	7.3
	460-3-60	9.5	40	6	27.5	1.1	6.2	21.2	30	30	7.3
	575-3-60	7.8	33	4.9	24	1	4.9	17.4	30	25	7.3

NOTES:

1. Table 18 is appropriate for both Steam and Hot Water Units.
2. Purge pump ratings are for the Welch model 1402.
3. Disconnect size in accordance with NEC. A Johnson Controls supplied 100 amp, non-fused, unit disconnect switch is in the power panel.

Electrical Data - continued

TABLE 18 – ELECTRICAL RATINGS - CONT.

Chiller Model	Voltage (Volts-Ph-Hz)	Solution Pump		Refrigerant Pump		Purge Pump		Minimum Circuit Ampacity	Disconnect Switch (Customer supplied)	Max-Dual Elem. Fuse (Customer supplied)	Total KW
		FLA	LRA	FLA	LRA	FLA	LRA				
6C4	200/208-3-60	20.0	78.0	12.5	51.0	2.1	14.2	44.6	60.0	60.0	7.3
	230-3-60	19.0	80.0	12.0	55.0	2.2	12.8	42.3	60.0	60.0	7.3
	380-3-50	14.0	65.0	6.5	23.0	1.1	5.4	27.7	30.0	40.0	9.7
	400-3-50	14.3	64.0	6.3	24.5	1.1	5.1	27.7	30.0	40.0	9.7
	460-3-60	9.5	40.0	6.0	27.5	1.1	6.2	21.2	30.0	30.0	7.3
	575-3-60	7.8	33.0	4.9	24.0	1.0	4.9	17.4	30.0	25.0	7.3
7D1	200/208-3-60	20.0	78.0	12.5	51.0	2.1	14.2	44.6	60.0	60.0	7.3
	230-3-60	19.0	80.0	12.0	55.0	2.2	12.8	42.3	60.0	60.0	7.3
	380-3-50	14.0	65.0	6.5	23.0	1.1	5.4	27.7	30.0	40.0	9.7
	400-3-50	14.3	64.0	6.3	24.5	1.1	5.1	27.7	30.0	40.0	9.7
	460-3-60	9.5	40.0	6.0	27.5	1.1	6.2	21.2	30.0	30.0	7.3
	575-3-60	7.8	33.0	4.9	24.0	1.0	4.9	17.4	30.0	25.0	7.3
7D2	200/208-3-60	33.0	107.0	12.5	51.0	2.1	14.2	60.9	100.0	90.0	9.7
	230-3-60	30.0	118.0	12.0	55.0	2.2	12.8	56.0	60.0	80.0	9.7
	380-3-50	14.0	65.0	6.5	23.0	1.1	5.4	27.7	30.0	40.0	9.7
	400-3-50	14.3	64.0	6.3	24.5	1.1	5.1	27.7	30.0	40.0	9.7
	460-3-60	15.0	59.0	6.0	27.5	1.1	6.2	28.1	30.0	40.0	9.7
	575-3-60	12.0	47.0	4.9	24.0	1.0	4.9	22.6	30.0	30.0	9.7
8D3	200/208-3-60	33.0	107.0	12.5	51.0	2.1	14.2	60.9	100.0	90.0	9.7
	230-3-60	30.0	118.0	12.0	55.0	2.2	12.8	56.0	60.0	80.0	9.7
	380-3-50	14.0	65.0	6.5	23.0	1.1	5.4	27.7	30.0	40.0	9.7
	400-3-50	14.3	64.0	6.3	24.5	1.1	5.1	27.7	30.0	40.0	9.7
	460-3-60	15.0	59.0	6.0	27.5	1.1	6.2	28.1	30.0	40.0	9.7
	575-3-60	12.0	47.0	4.9	24.0	1.0	4.9	22.6	30.0	30.0	9.7
8E1	200/208-3-60	33.0	107.0	12.5	51.0	2.1	14.2	60.9	100.0	90.0	9.7
	230-3-60	30.0	118.0	12.0	55.0	2.2	12.8	56.0	60.0	80.0	9.7
	380-3-50	14.0	65.0	9.5	38.0	1.1	5.4	30.7	60.0	40.0	11.2
	400-3-50	14.3	64.0	10.4	39.0	1.1	5.1	31.8	60.0	45.0	11.2
	460-3-60	15.0	59.0	6.0	27.5	1.1	6.2	28.1	30.0	40.0	9.7
	575-3-60	12.0	47.0	4.9	24.0	1.0	4.9	22.6	30.0	30.0	9.7
9E2	200/208-3-60	40.7	118.0	21.0	78.0	2.1	14.2	79.0	100.0	110.0	11.2
	230-3-60	36.8	130.0	19.0	80.0	2.2	12.8	71.5	100.0	100.0	11.2
	380-3-50	14.0	65.0	14.0	65.0	1.1	5.4	35.2	60.0	45.0	13.5
	400-3-50	14.3	64.0	14.3	64.0	1.1	5.1	35.7	60.0	50.0	13.5
	460-3-60	18.4	65.0	9.5	40.0	1.1	6.2	35.8	60.0	50.0	11.2
	575-3-60	15.0	52.0	7.8	33.0	1.0	4.9	29.3	30.0	40.0	12.6
10E3	200/208-3-60	40.7	118.0	33.0	107.0	2.1	14.2	91.0	100.0	125.0	13.5
	230-3-60	36.8	130.0	30.0	118.0	2.2	12.8	82.5	100.0	110.0	13.5
	380-3-50	14.0	65.0	14.0	65.0	1.1	5.4	35.2	60.0	45.0	13.5
	400-3-50	14.3	64.0	14.3	64.0	1.1	5.1	35.7	60.0	50.0	13.5
	460-3-60	18.4	65.0	15.0	59.0	1.1	6.2	41.3	60.0	50.0	13.5
	575-3-60	15.0	52.0	12.0	47.0	1.0	4.9	33.5	60.0	45.0	14.9
12F1	200/208-3-60	33.0	107.0	33.0	107.0	2.1	14.2	81.4	100.0	110.0	13.5
	230-3-60	30.0	118.0	30.0	118.0	2.2	12.8	74.0	100.0	100.0	13.5
	380-3-50	14.0	65.0	14.0	65.0	1.1	5.4	35.2	60.0	45.0	13.5
	400-3-50	14.3	64.0	14.3	64.0	1.1	5.1	35.7	60.0	50.0	13.5
	460-3-60	15.0	59.0	15.0	59.0	1.1	6.2	37.1	60.0	50.0	13.5
	575-3-60	12.0	47.0	12.0	47.0	1.0	4.9	29.7	60.0	40.0	13.5

NOTES:

1. Table 14 is appropriate for both Steam and Hot Water Units.
2. Purge pump ratings are for the Welch model 1402.
3. Disconnect size in accordance with NEC. A Johnson Controls supplied 100 amp, non-fused, unit disconnect switch is in the power panel.

Guide Specifications

GENERAL

Provide Single-Stage Steam (or Hot Water) Absorption Chiller(s) capable of producing chilled water per the capacities shown on drawings and schedules. Chiller shall be capable of starting and operating at entering condenser water temperatures as low as 45°F (7.2°C).

Each chiller shall be of hermetic design and factory helium leak tested.

(For YIA-1A1 to YIA-10E3) Chiller shall ship as a one-piece assembly in a vacuum. (For YIA-12F1 to YIA-14F3) Chiller shall ship as two pieces (upper and lower shells) for field assembly. Each shell shall be shipped charged with nitrogen. A modulating control valve shall be shipped loose for field installation.

All unit mounted controls and control panels shall be factory mounted, wired, tested, and shipped pre-installed as integral components of the chiller.

Unless supplied with a double walled evaporator, chiller shall include 3/4" (19.1 mm) neoprene insulation of the entire shell.

Purchase price shall include start-up service and parts and labor warranty for a period of one year from start-up or eighteen months from delivery, whichever occurs first.

CONSTRUCTION

The chiller shall consist of a generator, solution heat exchanger, absorber, condenser and an evaporator. The unit construction shall minimize the opportunity for internal leaks between the generator and evaporator sections through the use of a two-shell design, with the upper shell housing the higher pressure generator and condenser, and the lower shell housing the low pressure absorber and evaporator. To minimize the risk of corrosion, the evaporator and condenser pans shall be stainless steel.

The evaporator-absorber and the generator-condenser shall be of shell and tube construction. The steam generator section shall have a tube-side DWP of 150 PSIG (1.0 mPa) (limited by the ASME code to 15 PSIG (103 kPa) maximum working pressure): hot water generator shall be designed for 300 PSIG (2.0 mPa) DWP tube-side and tested to 450 PSIG (3.0 mPa). A shell-side bursting disk set to burst at 7 PSIG ± 2 PSIG (48 kPaG ± 14 kPaG) shall be furnished with all units.

TUBE MATERIALS

Generator tubes shall be 3/4" (19.1 mm), 0.035" (0.89 mm) wall 90/10 copper-nickel and allow for the removal of the tubes from either end of the machine. Evaporator

and absorber tubes shall be 3/4" (19.1 mm), 0.028" (0.71 mm) wall copper. Condenser tubes shall be copper and be sized to eliminate the need for contractor provided bypass piping [3/4" or 1" (19.1 mm or 25.4 mm)] with a wall thickness of 0.028" (0.71 mm). Tubes for the solution heat exchanger shall be 0.043" (1.9 mm) wall carbon steel.

WATER BOXES

Water boxes shall be removable to permit tube cleaning and replacement. Water circuit tubing to be replaceable from either end of the absorption unit. Stub-out water connections having Victaulic grooves shall be provided as standard (ANSI flanged connections are optional). All water boxes and associated water circuit nozzles and tube bundles shall be designed for 150 PSIG (1.0 mPa) working pressure and shall be hydrostatically tested to 225 PSIG (1.5 mPa). Vent and drain connections shall be provided on each water box. Manufacturers shall provide lifting lugs on each of the water boxes or install lifting lugs in the field.

The Generator Water boxes for steam applications are designed for 150 PSIG (1.0 MPa) working pressure and are tested at 225 PSIG (1.5 MPa). The steam working pressure is limited to the specified design pressure, which, under no circumstances, is to exceed 14 PSIG (198 kPa) at the generator. The steam connections are 150 PSIG ANSI flanges. The Generator water boxes for hot water applications are designed for 300 PSIG (2.17 MPa) and tested at 450 PSIG (3.20 MPa). The hot water connections are stub-out water connections with Victaulic grooves.

AUTOMATIC DECRYSTALLIZATION SYSTEM

Chiller shall include an automatic decrystallization system designed to remove any minor crystallization which may occur. System shall immediately detect a blockage in the heat exchanger through the use of thermal sensors and respond with the introduction of refrigerant water to dilute the strong solution entering the solution heat exchanger.

PUMPS

Solution and refrigerant pumps shall be hermetically sealed, self-lubricating, totally enclosed, factory-mounted, wired and tested. Motor windings shall not be exposed to lithium bromide or water. The suction and discharge connections for each pump shall be fully welded to the unit piping to minimize the opportunity for leaks. Suction and discharge connections shall be equipped with factory installed isolation valves to permit quick and easy servicing of pumps. Pumps shall be designed to operate for a total of 55,000 hours between service inspections.

PURGING SYSTEM

Absorber shall be equipped with a purging system to remove non-condensable vapors from the unit during op-

Guide Specifications - continued

eration. Non-condensibles shall be drawn from a purge header located in the absorber and removed through the operation of an electric vacuum pump.

The purge pump shall be of an oil rotary single-stage design, and shall be furnished complete with a ½ hp (0.68 kW), 3-Phase TEFC motor, and all required accessories. The purge pump shall be shipped mounted on the chiller and connecting hose shall be field installed by installing contractor at the job site.

PURGING SYSTEM

Absorber shall be equipped with a purging system to remove non-condensibles vapors from the unit during operation. Non-condensibles shall be drawn from a purge header located in the absorber and removed through the operation of an electric vacuum pump.

The purge pump shall be of an oil rotary single-stage design, and shall be furnished complete with a ½ hp (0.68 kW), 3-Phase ODP motor, and all required accessories. The purge pump shall be shipped mounted on the chiller and connecting hose shall be field installed by installing contractor at the job site.

LITHIUM BROMIDE AND REFRIGERANT CHARGE

Lithium bromide shall contain ADVAGuard™ 750 corrosion inhibitor additive to minimize the rate of copper and ferrous metal corrosion on both the solution and refrigerant sides of the unit. Deionized water shall be supplied for the refrigerant charge. Solution and refrigerant to ship separate from the chiller for charging at the job site.

STEAM/HOT WATER VALVE

Steam Fired chillers shall be furnished with a steam control valve, linkage and the actuator motor. This assembly shall be shipped loose for field installation. The steam valve shall be cage or butterfly style

1. The cage valve should have a cast iron or carbon steel body.
2. The butterfly valve should have a stainless steel body. The steam control valve assembly shall be capable of modulating steam flow continuously from 10% to 100% of the maximum design chiller capacity. The valve shall be equipped with ANSI flange connections.

Hot Water chillers shall be furnished with a 3-way diverting type valve, linkage and the actuator motor. This assembly shall be shipped loose for field installation. The valve shall feature a cast iron or carbon steel body. The 3-way valve assembly shall be capable of modulating hot water flow continuously from 10% to 100% of the maximum design

chiller capacity into the chiller. The valve shall be equipped with ANSI flange connections.

The actuator motor shall be 120V/1-Ph/60Hz, and shall be powered from the chiller's OptiView Control Panel. Actuator motor position to be controlled via the OptiView Control Panel through a 4-20 mA control signal.

UNIT CONTROLS

Each unit shall be furnished complete with a factory mounted and pre-wired control system. Unit controls to be furnished shall include a total of two (2) enclosures; a power panel and a OptiView control panel.

Power Panel – The power panel enclosure shall be NEMA 1 and shall house the following components: single point wiring connection for incoming power supply; non-fused disconnect switch; motor starters, complete with current and thermal overload protection, for solution pump(s), refrigerant pump, and purge pump (current overloads only); and a 115 VAC 50/60 Hz control power transformer.

OptiView Control Center – The control panel enclosure shall be NEMA 1 and be equipped with hinged access door with lock and key. All temperature sensors, pressure transducers, and other control devices necessary to sense unit operating parameters to be factory mounted and wired to panel. The control center panel shall include a 40 character alphanumeric display showing all system parameters in the English language with numeric data in English (or Metric) units (°F, PSIGA, or °C, kPa, respectively).

The operating program shall be stored in non-volatile memory (EPROM) to eliminate chiller failure due to AC power failure/battery discharge. In addition, programmed setpoints shall be retained in lithium battery-backed RTC memory for a minimum of 5 years.

115V control voltage will be supplied through a 1 KVA power transformer located in the power panel and will be factory wired to the OptiView control panel. Terminal blocks will be provided for all external safety and control interlocks.

System Operating Information – During normal operation the following operating parameters shall be accessible via the OptiView control panel:

- Return and leaving chilled water temperatures
- Return and leaving condenser water temperatures
- Inlet steam pressure
- Refrigerant temperature
- Solution temperature

- Solution concentration
- Indication of refrigerant/solution/purge pump operation
- Operating hours Number of starts
- Number of Purge Cycles (last 7 days and total cumulative)
- Inlet steam or hot water temperature
- Steam or hot water valve actuator potentiometer position (in %)
- Generator shell pressure
- Automatic decrystallization or hot water temperature

Capacity Control – The control panel shall automatically control the input steam or hot water flow rate to maintain the programmed leaving chilled water setpoint for cooling loads ranging from 20% to 100% of design. The input steam or hot water flow rate shall also be manually adjustable from the OptiView control panel to any setting between minimum and maximum when automatic operation is not desired and when steam or hot water input is not being inhibited by a specific operating condition.

Safety Shutdowns – Panel shall be pre-programmed to shut the unit down and close “safety shutdown” contacts under any of the following conditions:

- Refrigerant or solution pump thermal or current overload
- Low refrigerant temperature
- Generator high pressure
- Loss of chilled water flow
- Power failure (when “Automatic Restart after Power Failure” option is not utilized)
- High inlet steam or hot water temperature
- High inlet steam pressure
- Incomplete dilution cycle operation due to one of the following conditions:
 - Power failure
 - Solution/refrigerant pump overloads
 - Low refrigerant temperature
 - Loss of chilled water flow
 - External auxiliary safety shutdown
 - High solution concentration

All safety shutdowns will require the unit to be manually restarted.

Whenever a safety shutdown occurs, the OptiView control panel shall record the following information and store it in memory (or communicate it to a remote printer):

- Day and time of shutdown

- Reason for shutdown
- Type of restart required (automatic restart is displayed, manual restart is implied)
- All system operating information displayed just prior to shutdown

Warning Conditions – OptiView control panel shall close warning contacts and generate a unique warning message whenever one of the following operating conditions is detected:

- Low refrigerant temperature
- High generator pressure
- High inlet hot water temperature
- High inlet steam pressure
- High entering condenser water temperature
- Purge pump current overload
- Faulty strong solution dilution temperature sensor

Cycling Shutdowns – Control panel shall be pre-programmed to shut unit down whenever one of the following conditions is detected:

- Loss of condenser water flow
- Low leaving chilled water temperature (2°F below setpoint)
- Power failure (when “Automatic Restart after Power Failure” option is selected)

Data Logging – The OptiView control panel shall contain an RS-232 port to enable the transmission of all operating, setpoint, and shutdown information to a remote printer (printer supplied by others). This transmission can occur as needed or automatically at predetermined intervals (0.1 to 25.5 hr). In the case of a safety or cycling shutdown, the RS-232 port shall transmit all operating data detected prior to the shutdown as well as the time and cause of the shutdown to a remote printer (printer supplied by others). In addition, a history of the last four safety or cycling shutdowns and operating data, with the exception of power failures, shall be retained in memory and can be printed as well.

Energy Management Interface – When connected to a BAS interface provided by the chiller manufacturer, the OptiView control panel shall be able to communicate all data accessible from the keypad to a remote integrated DDC processor through a single shielded cable. This information will include all unit temperatures, pressures, safety alarms, and status readouts for complete integrated plant control, data logging, and local/remote display of operator information. The single shielded cable shall also allow the remote integrated DDC processor to issue

Guide Specifications - continued

operating commands to the control center including but not limited to the following:

- Remote unit start/stop
- Remote chilled water temperature reset
- Remote steam limit input

The OptiView Control Panel shall also be capable of providing a limited interface to other building automation systems which are not provided by the chiller manufacturer in order to permit the following operations:

- Remote unit start/stop
- Remote chilled water temperature reset
- Remote steam limit input
- Remote readout of status including:
 - Unit ready to start
 - Unit operating
 - Unit safety shutdown
 - Unit cycling shutdown



Printed on recycled paper

Form 155.16-EG3 (1010) New Release

© 2010 Johnson Controls, Inc. P.O. Box 423, Milwaukee, WI 53201 Printed in USA
www.johnsoncontrols.com

