



Form 1247E

**E-TRAC<sup>®</sup>**  
**X2C**  
**Series AC Inverters**

***User's Manual***



**TB WOOD'S INCORPORATED**  
Chambersburg, Pennsylvania

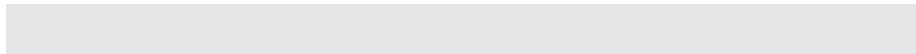

**TRADEMARK NOTICE**

TB Wood's, E-trAC, **E-TRAC**<sup>®</sup>, and  are registered trademarks of TB Wood's Incorporated.

**SECTION 1: INTRODUCTION**

1.1 Scope of Manual . . . . . 1  
1.2 Manual Revision Level . . . . . 1  
1.3 Related Documentation . . . . . 1

**SECTION 2: SPECIFICATIONS**

2.1 Model Number . . . . . 3  
2.2 Technical Characteristics . . . . . 4  
2.3 Dimensions and Weights . . . . . 5  
2.4 Power and Current Ratings. . . . . 9

**SECTION 3: RECEIVING AND INSTALLATION**

3.1 Preliminary Inspection. . . . . 11  
3.2 Installation Precautions. . . . . 12  
3.3 Explosion-Proof Applications . . . . . 13  
3.4 Line Starting . . . . . 14

**SECTION 4: CONNECTIONS**

4.1 Terminal Access Cover Removal for NEMA 1 Enclosures. . . . . 15  
4.2 Power Terminals . . . . . 17  
4.3 Control Terminals . . . . . 19  
4.4 J20 Configuration . . . . . 21  
4.5 J22 Option Connector. . . . . 22  
4.6 Input Line Requirements . . . . . 23  
    A. Line Voltage . . . . . 23  
    B. Line Capacity . . . . . 23  
    C. Phase Imbalance . . . . . 23  
    D. Single Phase Operation of 0.5 to 5 HP Inverters . . . . . 24  
4.7 Line Protection . . . . . 24  
    A. Fuse Sizing and Type . . . . . 24  
4.8 Wiring . . . . . 25  
    A. Applicable Codes . . . . . 25  
    B. General Wiring Practices . . . . . 25  
    C. Power Wiring. . . . . 26  
    D. Control Wiring . . . . . 27  
4.9 Reducing Current Surges and Voltage Transients . . . . . 27  
4.10 Connection Diagrams . . . . . 28

## Table of Contents

### SECTION 5: RFI SUPPRESSION AND XLF LINE FILTERS

5.1	Introduction . . . . .	33
5.2	XLF Series Filter Specifications . . . . .	34
5.3	XLF Series Filter Dimensions . . . . .	35
5.4	Installing XLF Line Filters . . . . .	36
	A. Receiving Filters . . . . .	36
	B. Mounting Filters . . . . .	36
	C. Connecting Filters . . . . .	36
5.5	Interference Suppression Measures (Electromagnetic Compatibility) . . . . .	38

### SECTION 6: GETTING STARTED

6.1	Introduction . . . . .	41
6.2	Keypad Operation . . . . .	42
6.3	Status Indicator . . . . .	44
6.4	LCD Display . . . . .	44
6.5	Programming Tips . . . . .	45
	A. Accessing Parameters . . . . .	45
	B. Changing Display Scroll Rate . . . . .	46
	C. Restoring Factory Settings . . . . .	46
	D. Getting Help . . . . .	46
6.6	Quick Start . . . . .	47

### SECTION 7: PARAMETER CONFIGURATION AND DESCRIPTION

7.1	Programming . . . . .	49
7.2	Parameter Descriptions . . . . .	50
	A. View-Only Parameters . . . . .	50
	B. Programmable Parameters . . . . .	52

**SECTION 8: PI CONTROLLER**

8.1	Introduction . . . . .	73
8.2	Overview of PI Control . . . . .	73
8.3	Reference and Feedback Inputs . . . . .	75
	A. Configuration of Inputs . . . . .	75
	B. Scaling the Feedback Input . . . . .	76
8.4	Calculating PI Controller Values . . . . .	76
8.5	Parameters for PI Control . . . . .	78
	A. Additional Parameters for PI Control . . . . .	78
	B. Parameters Re-Defined for PI Control . . . . .	79

**SECTION 9: TROUBLESHOOTING**

9.1	Special Indications . . . . .	83
9.2	Fault Trip Indications . . . . .	84
9.3	Resetting a Fault . . . . .	84
9.4	Fault Codes . . . . .	85
9.5	Troubleshooting Procedures . . . . .	86

**SECTION 10: OPTIONS AND REPLACEMENT PARTS**

10.1	Hassle-Free Warranty . . . . .	87
10.2	E-trAC X2C Series Options . . . . .	87
	A. XRK01 - Remote Keypad Unit . . . . .	87
	B. XPM01 - Program Memory Unit . . . . .	87
	C. XRP01 - Remote Panel Keypad . . . . .	88
	D. XRP02 - Remote Panel Programmer . . . . .	88
10.3	WDBxxx External Dynamic Braking Package . . . . .	88
10.4	Replacement Parts - 0.5 to 5 HP Models . . . . .	89
10.5	Replacement Parts - 7.5 to 20 HP Models . . . . .	90

## Table of Contents

### **APPENDIX A: SUMMARY OF X2C PARAMETERS**

- A.1 Summary of X2C Parameters When PI Control Is Not Utilized. . . . . A-1
- A.2 Parameters Added or Amended When PI Control Is Utilized . . . . . A-4

### **APPENDIX B: EU DECLARATION OF CONFORMITY - 98**

- B.1 TB Wood's Declaration of Conformity. . . . . B-1

---

## **Section 1: Introduction**

### **1.1 Scope of Manual**

This manual contains specifications, receiving and installation instructions, configuration, description of operation, and troubleshooting procedures for the E-trAC X2C AC Inverters. The X2C Series is a family of 0.5 to 20 HP, 115, 230, and 460 VAC inverters. The line consists of 61 models in 5 frame sizes.

### **1.2 Manual Revision Level**

This manual, known as Form 1247D and dated December 2000, is the fifth release of Form 1247.

### **1.3 Related Documentation**

Form 1199, *TB Wood's WLF and XLF Series Line Filters*, is also available for X2C Series AC Inverters.

**NOTES**

## Section 2: Specifications

### 2.1 Model Number

The model number of the E-trAC X2C inverter appears on the shipping carton label and on the technical data label affixed to the device. The model number indicates the inverter's torque output, input voltage rating, horsepower rating, and enclosure type. Figure 1 lists the codes found in the model number and what each means.

For example, model X2C2001-0B is a constant torque E-trAC X2C Series inverter in a NEMA 1 enclosure with keypad, rated 1.0 HP, with input voltage of 230 VAC.

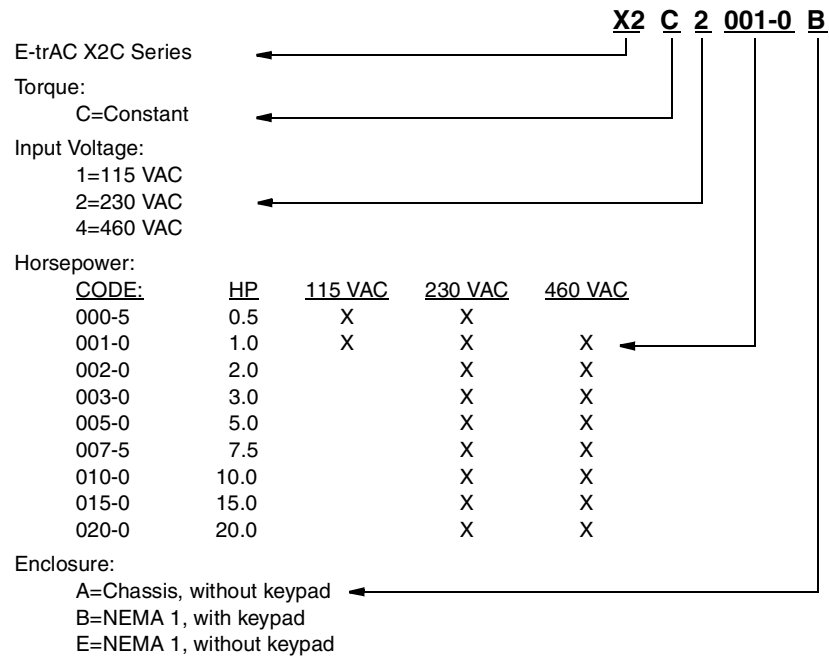

**Figure 1: Interpreting X2C Model Numbers**



Table 2: Protection Features

Ground fault	Protected from damage (full-time)
Short circuit	Protected from damage
Motor overload	Programmable inverse time overload trip
Overvoltage	Protected from damage. 500 mS ride-through
Undervoltage	Protected from damage. 200 mS ride-through, load dependent
MOL input terminal	Programmable for N.C. or N.O. contacts
Torque limit	Full-time four quadrant "Trip-Free" operation
Over temperature	Protected from damage, warning display

2.3 Dimensions and Weights

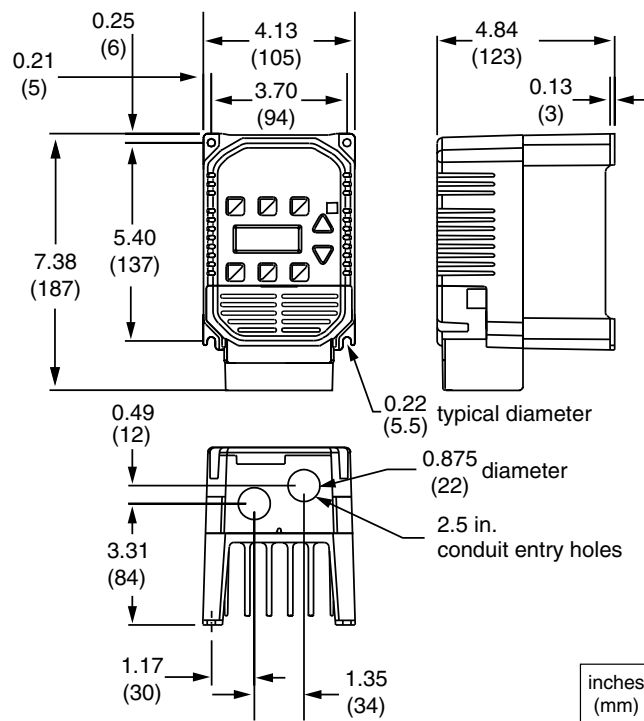

NOTE: On chassis models supplied without covers and conduit plates, depth = 4.68 (119).

Figure 2: 0.5 HP 115 VAC, 0.5 to 1.0 HP 230 VAC, and 1 HP 460 VAC, NEMA 1

## Section 2: Specifications

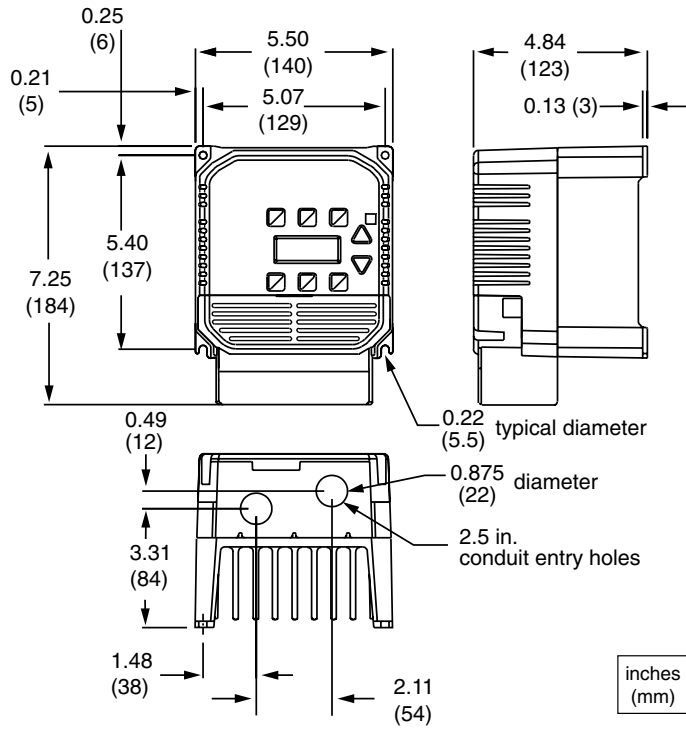

NOTE: On chassis models supplied without covers and conduit plates, depth = 4.68 (119).

**Figure 3: 1.0 HP 115 VAC, 2.0 HP 230 and 460 VAC, NEMA 1**

**Table 3: Weights: 0.5 to 2 HP, NEMA 1**

Enclosure Type	0.5 and 1 HP Inverters		2 HP Inverters	
	lb	kg	lb	kg
Model A: Chassis without keypad	4	1.8	5	2.25
Model B: NEMA 1 with keypad	4	1.8	5	2.25
Model E: NEMA 1 without keypad	4	1.8	5	2.25

**Section 2: Specifications**

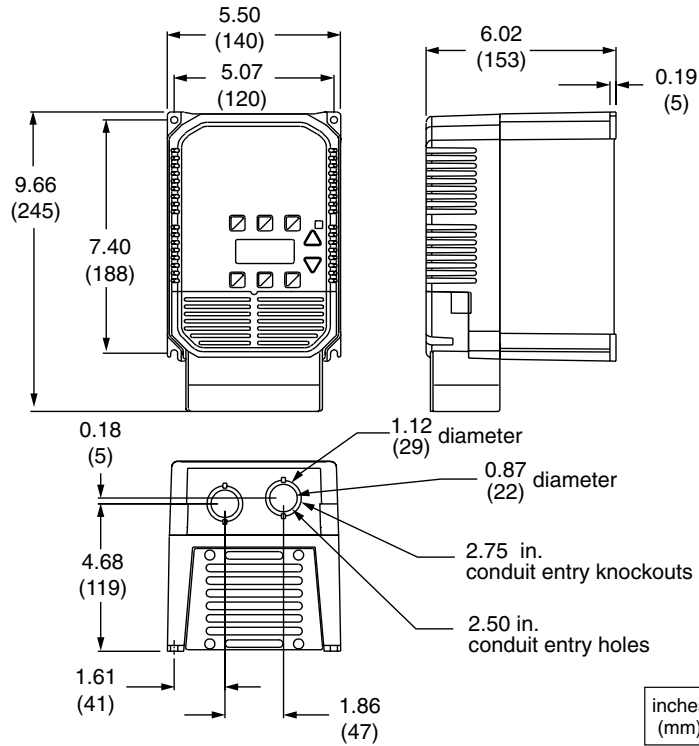

NOTE: On chassis models supplied without covers and conduit plates, depth = 5.81 (229).

**Figure 4: 3 and 5 HP, NEMA 1**

**Table 4: Weights: 3 and 5 HP, NEMA 1**

Enclosure Type	3 HP Inverters		5 HP Inverters	
	lb	kg	lb	kg
Model A: Chassis without keypad	8.9	4.00	9.0	4.05
Model B: NEMA 1 with keypad	9.0	4.05	9.1	4.09
Model E: NEMA 1 without keypad	8.9	4.00	9.0	4.05

## Section 2: Specifications

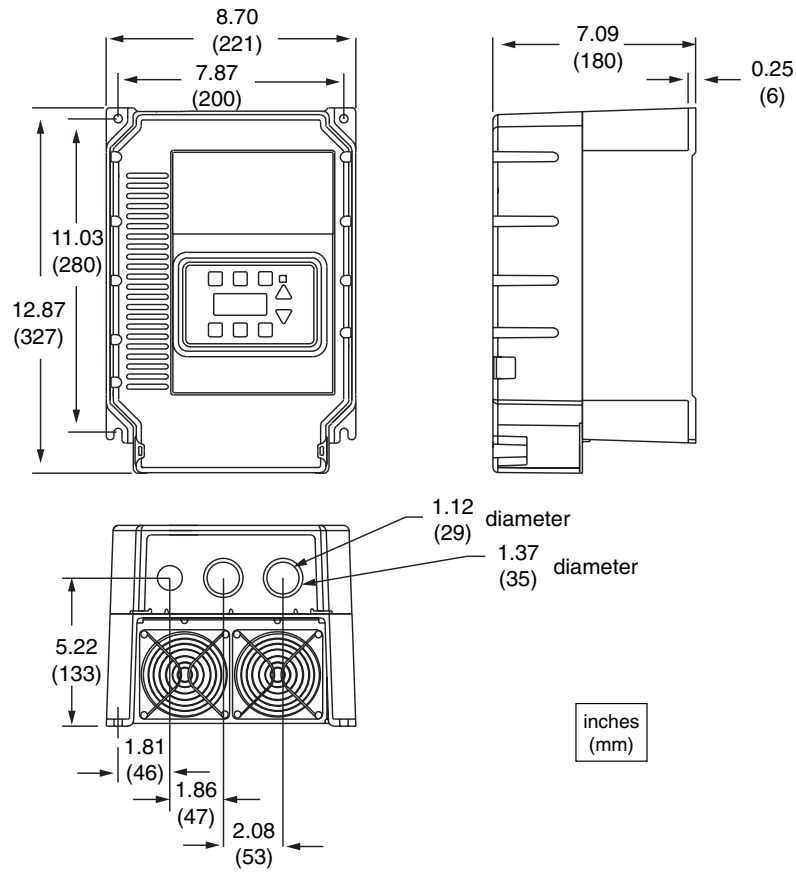

Figure 5: 7.5 to 20 HP 230 and 460 VAC, NEMA 1

Table 5: Weights: 7.5 to 20 HP 230 and 460 VAC, NEMA 1

Enclosure Type	7.5 to 20 HP Inverters	
	lb	kg
Model B: NEMA 1 with keypad	21	9.45

2.4 Power and Current Ratings

Table 6: Power and Current Ratings, 0.5 to 5 HP CT

Model Number	Motor Power				Input Voltage	Input Current		Maximum Input kVA		Output Voltage	Maximum Continuous Output Current <sup>[1]</sup>		
	3 Ø		1 Ø			3 Ø	1 Ø	3 Ø	1 Ø		3 Ø	3 Ø Input	1 Ø Input
	HP	kW	HP	kW		VAC	A	A	kVA		kVA	VAC	A
1000-5x	—	—	0.5	0.37	115 (± 10%)	—	4.5	—	0.52	3.5-230	—	2.2	
1001-0x	—	—	1.0	0.75		—	8.9	—	1.02		—	4.0	
2000-5x	0.5	0.37	0.33	0.25	200-230 (-10%, +15%)	1.9	2.2	0.76	0.51	3.5-230	2.2	1.8	
2001-0x	1.0	0.75	0.75	0.55		3.8	4.4	1.51	1.01		4.0	3.1	
2002-0x	2.0	1.5	1.5	1.1		7.5	8.1	2.99	1.86		7.5	5.7	
2003-0x	3.0	2.2	2.0	1.5		10.4	14.5	4.15	3.34		10.6	7.5	
2005-0x	5.0	3.7	3.0	2.2		17.6	21.0	7.01	4.83		16.7	10.5	
4001-0x	1.0	0.75	—	—	380-460 (-10%, +15%)	2.3	—	1.83	—	7.0-460	2.2	—	
4002-0x	2.0	1.5	—	—		5.1	—	4.06	—		4.1	—	
4003-0x	3.0	2.2	—	—		6.2	—	4.94	—		6.1	—	
4005-0x	5.0	3.7	—	—		10.8	—	8.60	—		9.9	—	

1. Maximum inverter capacity. Value = 1.1 x 03-IRAT (see Table 18 on page 51 for the values of 03-IRAT).

Table 7: Power and Current Ratings, 7.5 to 20 HP CT and VT

Model Number	Motor Power				Input Voltage	Input Current	Max. Input kVA	Output Voltage	Motor Current <sup>[1]</sup>		Maximum Continuous Output Current <sup>[2]</sup>
	CT		VT						CT	VT	
	HP	kW	HP	kW					VAC	A	
2007-5x	7.5	5.5	—	—	200-230 (-10%, +15%)	26.9	10.7	3.5-230	22	—	24.2
2010-0x	10	7.5	—	—		34.2	13.6		28	—	30.8
2015-0x	15	11	—	—		54.3	21.6		42	—	46.2
2020-0x	20	15	—	—		68.2	27.2		54	—	59.4
4007-5x	7.5	5.5	10	7.5	380-460 (-10%, +15%)	16.0	12.8	7.0-460	13	14.3	14.3
4010-0x	10	7.5	15	11		22.2	17.7		18	19.8	19.8
4015-0x	15	11	20	15		31.0	24.7		24	26.4	26.4
4020-0x	20	15	25	18.6		37.9	30.2		30	33	33

1. Maximum motor nameplate full load current.

2. Maximum inverter capacity. Value = 1.1 x 03-IRAT (see Table 18 on page 51 for the values of 03-IRAT).

**NOTES**

---

## Section 3: Receiving and Installation

### 3.1 Preliminary Inspection

Before storing or installing the E-trAC X2C Series inverter, thoroughly inspect the device for possible shipping damage. Upon receipt:

1. Remove the inverter from its package and inspect exterior for shipping damage. If damage is apparent, notify the shipping agent and your sales representative.
2. Remove the cover (see page 16) and inspect the inverter for any apparent damage or foreign objects. Ensure that all mounting hardware and terminal connection hardware is properly seated, securely fastened, and undamaged.
3. Read the technical data label affixed to the inverter and ensure that the correct horsepower and input voltage for the application has been purchased.
4. If you will store the inverter after receipt, place it in its original packaging and store in a clean, dry place free from direct sunlight or corrosive fumes, where the ambient temperature is not less than -20 °C (-4 °F) or greater than +60 °C (+140 °F).

#### CAUTION

##### **EQUIPMENT DAMAGE HAZARD**

Do not operate or install any inverter that appears damaged.

**Failure to follow this instruction can result in injury or equipment damage.**

#### ATTENTION

##### **RISQUE DE DOMMAGES MATÉRIELS**

Ne faites pas fonctionner et n'installez pas tout onduleur qui semble être endommagé.

**Si cette directive n'est pas respectée, cela peut entraîner des blessures corporelles ou des dommages matériels.**

## Section 3: Receiving and Installation

### 3.2 Installation Precautions

Improper installation of the inverter will greatly reduce its life. Be sure to observe the following precautions when selecting a mounting location. *Failure to observe these precautions may void the warranty!*

1. Do not install the inverter in a place subjected to high temperature, high humidity, or excessive vibration. See Table 1 on page 4 for temperature, humidity, and maximum vibration limits.
2. Do not mount the inverter near heat radiating elements or in direct sunlight.
3. Mount the inverter vertically and do not restrict the air flow to the heat sink fins.
4. The E-trAC X2C Series inverter generates heat. Allow sufficient space around the unit for heat dissipation. See Figure 6 for required minimum clearances.
5. The operation of the inverter generates heat due to inefficiencies within the system. When installing the inverter inside another enclosure, this heat must be considered and, if necessary, removed to keep the ambient temperature within range (see Table 1 on page 4 for operating temperature). Table 8 shows the watts generated by the inverter when at full current. The heat generated is dependent on the carrier frequency used. For carrier frequencies other than those shown in Table 8, consult the factory or use the worst-case scenario (16 kHz carrier).

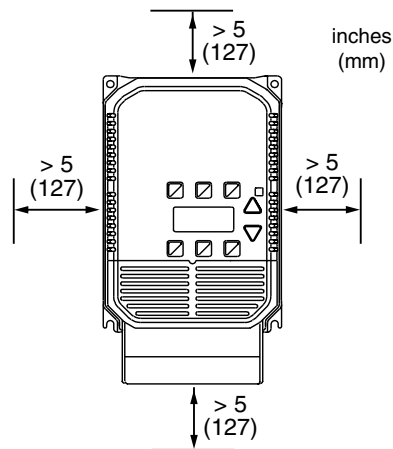

Figure 6: Minimum Clearances

Table 8: Heat Generated by Inverter (in Watts)

Inverter Model Number	@ 4 kHz Carrier	@ 16 kHz Carrier
X2C1000-5x	24	32
X2C1001-0x	42	47
X2C2000-5x	19	27
X2C2001-0x	37	42
X2C2002-0x	66	75
X2C2003-0x	70	79
X2C2005-0x	129	154
X2C2007-5x	250	385
X2C2010-0x	320	485
X2C2015-0x	440	675
X2C2020-0x	625	1020
X2C4001-0x	40	62
X2C4002-0x	67	99
X2C4003-0x	118	186
X2C4005-0x	184	281
X2C4007-5x	280	640
X2C4010-0x	360	790
X2C4015-0x	470	1120
X2C4020-0x	610	1400

- When mounting an inverter in another enclosure (with the heat sink fins inside the enclosure) consult TB Wood's for enclosure sizing and mounting instructions.

### 3.3 Explosion-Proof Applications

Explosion-proof motors that are not rated for inverter use lose their certification when used for variable speed. Due to the many areas of liability that may be encountered when dealing with these applications, the following statement of Company Policy applies:

*TB Wood's Incorporated AC Inverter products are sold for suitability with explosion-proof AC motors rated for use with Pulse Width Modulation (PWM) inverters. These motors must be UL listed for use with either TB Wood's AC inverters or with PWM inverters and used within the specified speed ranges and carrier frequencies. TB Wood's accepts no responsibility for any direct, incidental or consequential loss, cost or damage associated with the misapplication of our AC products*

### Section 3: Receiving and Installation

*in these applications. In any misapplication, the purchaser expressly agrees to assume all risk of loss, cost or damage that may arise. TB Wood's Incorporated will not knowingly approve the application of their AC inverters with motors not rated for such applications.*

#### 3.4 Line Starting

E-trAC X2C inverters are designed to provide controlled starting and stopping of AC motors by use of the keypad or external contacts connected to the control terminal strip (see page 17). The inverter may also be started by using a maintained contact (2-wire operation) and applying AC power to terminals L1, L2, and L3 (see page 17). To prevent accidental starting of the motor, the inverter has line-start-lockout as a standard feature. This provision can be defeated by programming 82-START (see page 68).

The inverter may be started once every two minutes in the line starting mode.

---

## Section 4: Connections

### **DANGER**

#### **HAZARDOUS VOLTAGE**

Before servicing the electrical system:

- Disconnect all power.
- Wait one minute until DC bus capacitors discharge.

**Failure to observe this instruction will result in death or serious injury.**

### **DANGER**

#### **TENSION DANGEREUSE**

Avant d'entretenir le système électrique:

- Coupez toute source d'alimentation.
- Attendez une minute que la décharge des condensateurs du bus CC s'effectue.

**Si cette directive n'est pas respectée, cela entraînera la mort ou des blessures graves.**

### 4.1 Terminal Access Cover Removal for NEMA 1 Enclosures

NEMA 1 versions of the E-trAC X2C inverter are designed to prevent accidental removal of the terminal access cover. The cover mounting meets UL and NEC specifications for safety.

To remove the access cover from **0.5 to 5 HP inverters**, loosen the two 8/32 screws mounted at the lower corners of the cover (see Figure 7). When replacing the cover, a snug fit only is required. **DO NOT** torque the screws or damage to the cover may result.

To remove the access cover from **7.5 to 20 HP inverters**, insert a small blade screwdriver into the slots located on the lower left and right corners of the cover (see Figure 8). Use a slight twisting motion while lifting upward to loosen one side then the other, and then lift the cover off the inverter. To replace, hook the cover onto the two retainers on top of the inverter base and snap the cover into place.

**Section 4: Connections**

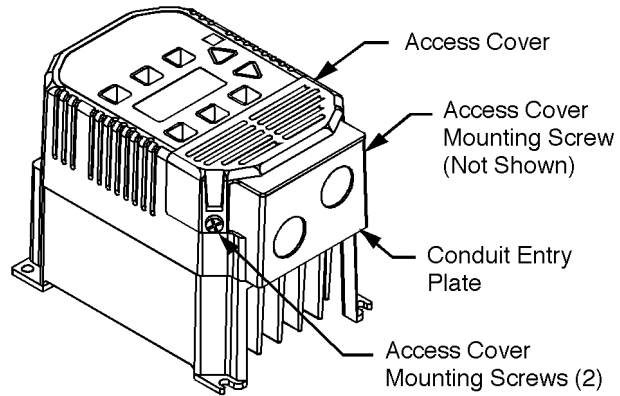

**Figure 7: Removing Cover From 0.5 to 5 HP NEMA 1 Inverters**



**Figure 8: Removing Cover From 7.5 to 20 HP Inverters**

4.2 Power Terminals

Power terminals are located on the power module of E-trAC X2C 0.5-5 HP inverters, and on the power board of the 7.5 to 20 HP models. They are labeled L1, L2, and L3 for incoming three-phase AC line power, and M1, M2, and M3 for the motor connections. For 0.5 to 5 HP models, note that incoming power leads L1, L2, and L3 **must** run through the ground fault CT before being fastened to the terminals. (The ground connection should **not** run through the ground fault CT.)

Two ground connections (GND) are provided on the end plate of 0.5 to 5 HP NEMA 1 models (see Figure 9), and along the power terminal strip of 7.5 to 20 HP NEMA 1 models (see Figure 10). Ground connections can be made to the heat sink on chassis models. The ground screws must be connected to earth ground in accordance with the NEC.

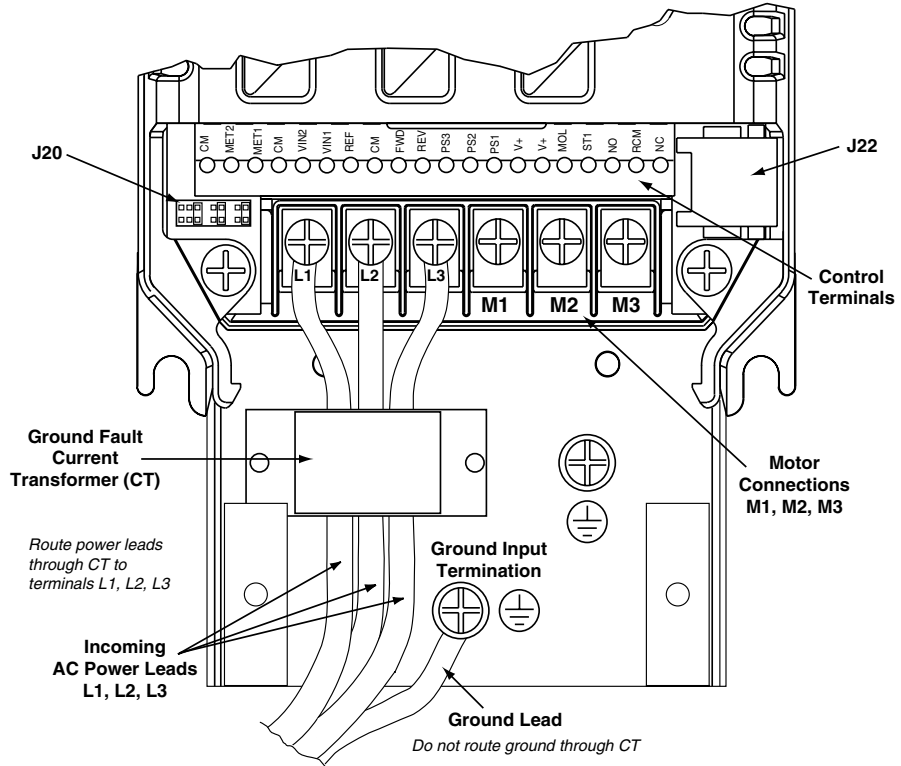
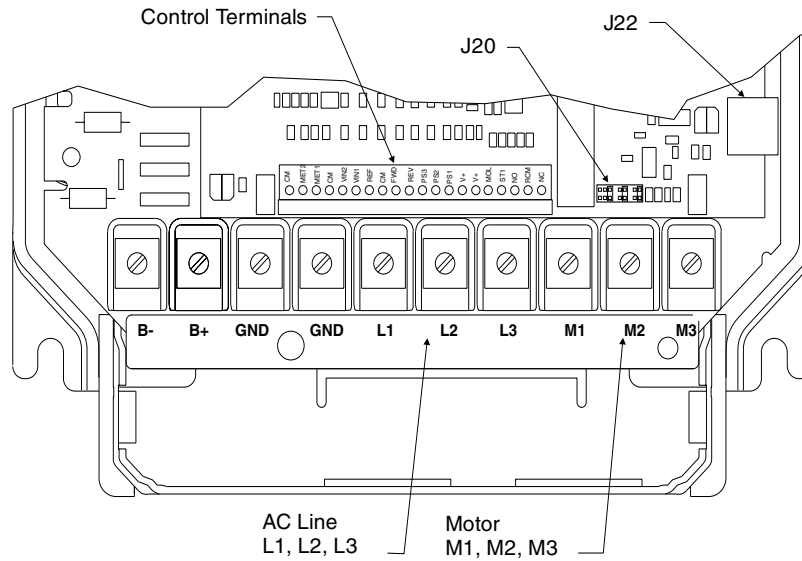

Figure 9: Terminal Locations, 0.5 to 5 HP Inverters

## Section 4: Connections



**Figure 10: Terminal Locations, 7.5 to 20 HP Inverters**

7.5 to 20 HP X2C inverters also have two terminals, B+ and B-, that provide access to the DC bus rails for the addition of external dynamic braking kits, or extra bus capacitors for custom applications.

**Table 9: Terminal Torque Values**

Terminal Type	lb-in	N•m
0.5 to 5 HP Inverters		
Power	10	1.128
Control	2.5	0.282
7.5 to 20 HP Inverters		
Power	30	3.390
Control	2.5	0.282

### 4.3 Control Terminals

The X2C inverter has a 20-position control terminal block at the bottom edge of its control board. (See Figure 9 on page 17 and Figure 10 on page 18.) These terminals are available for use with external devices. *Note: control input signals must not exceed 24 VDC + 20% potential to ground.*

**Table 10: Control Terminal Description**

Terminal	Description
CM	Circuit common, isolated from ground.
MET1	Analog meter output 1. Provides a 0 to 10 VDC (1 mA maximum) signal proportional to output frequency, load, or current through setting of 71-METER (see page 64). May be calibrated while inverter is running by programming 70-MCAL (see page 63). Output impedance is 475Ω.
MET2	Analog meter output 2. Provides a 0 to 20 mA or 4-20 mA signal proportional to output frequency, load, or current through setting of 79-MET2 (see page 67). May be calibrated while inverter is running by programming 78-MCAL2 (see page 66). Output impedance is 10Ω.
VIN1	Analog speed input 1. Selectable through jumper J20 for 0-5 VDC, 0-10 VDC, or 0/4-20 mA DC. A 4 mA offset is programmed by 24-FSEL (see page 53). Speed Reference can be defined through 24-FSEL as VIN1, VIN1 + VIN2, or VIN1 - VIN2. Also, switching between VIN1 and VIN2 is achieved with Auto/Manual function.
VIN2	Analog speed input 2. Selectable through jumper J20 for 0-5 VDC or 0-10 VDC. Speed Reference can be defined through 24-FSEL as VIN1, VIN1 + VIN2, or VIN1 - VIN2. Also, switching between VIN1 and VIN2 is achieved with Auto/Manual function.
REF	5.0 VDC reference voltage, 3 mA maximum load. Use only for a frequency control potentiometer (5 kΩ recommended).
FWD	Digital input for Forward operation. May be programmed for maintained (standard) or momentary contacts by 21-MODE (see page 52).
REV	Digital input for Reverse operation. May be programmed for maintained (standard) or momentary contacts by 21-MODE (see page 52).
V+	Positive nominal 12 VDC voltage. Only for use with digital inputs and ST1 Digital Output (75ma max.) See connection diagrams on pages 28 through 32. NO other use is allowed.
MOL	Motor Overload relay input. May be configured to generate a fault on opening or closing. May also be configured to command a Coast-to-Stop on opening or closing. See page 66.
PS1 PS2 PS3	Digital inputs normally used for preset speed selection. Jumper J20 selects pull-up or pull-down logic (see page 21). PS3 can be defined as a Run/Jog selector or Auto/Manual Switch by 21-MODE (see page 52), or as the ART selector by 41-RSEL (see page 55), unless the PI Regulator is enabled and PS3 is used as an ON/OFF switch.  Eight preset speeds are available if all three inputs are used, while only four are available if PS3 is redefined via parameters 21-MODE or 41-RSEL, or when the PI Regulator is enabled and PS3 is used as an ON/OFF switch. See the following page for the speed references that result from the input states of PS1, PS2, and PS3.

## Section 4: Connections

**Table 10: Control Terminal Description (continued)**

Terminal	Description			
PS1, PS2, PS3	PS1	PS2	PS3	Effective Speed Reference
	0	0	0	Basic speed setpoint (keypad or terminal)
	1	0	0	33-F2
	0	1	0	34-F3
	1	1	0	35-F4
	0	0	1	36-F5
	1	0	1	37-F6
	0	1	1	38-F7
	1	1	1	32-FMAX
PS1, PS2 <sup>[1]</sup>	0	0	N/A	Basic speed setpoint (keypad or terminals)
	1	0	N/A	33-F2
	0	1	N/A	34-F3
	1	1	N/A	35-F4
ST1	Digital output (open transistor collector). May be set to activate under one of ten conditions. See 72-ST1 (page 65).			
NO	Normally open contact for the auxiliary relay. Will close when the relay is activated. Rating is 115 VAC at 1 A.			
RCM	Auxiliary relay common terminal. Factory programmed as a Fault relay but may be set to activate under one of ten conditions. See 75-STR (page 65).			
NC	Normally closed contact for the auxiliary relay. Will open when the relay is activated. Rating is 115 VAC at 1 A.			

1. These settings will be utilized when PS3 is redefined via parameter 21-MODE or 41-RSEL, or when the PI Regulator is enabled and PS3 is used as an ON/OFF switch.

**Table 11: Logic Input Levels**

Logic Type	Pull-Up	Pull-Down
Active	10 - 24 VDC	0 - 3 VDC
Inactive	0 - 3 VDC	10 - 24 VDC

The input logic is compatible with either 12 or 24 VDC logic. J20 selects active High or Low control inputs (see page 21).

#### 4.4 J20 Configuration

### DANGER

#### HAZARDOUS VOLTAGE

Before setting the J20 jumper:

- Disconnect all power.
- Wait one minute until DC bus capacitors discharge.

**Failure to observe this instruction will result in death or serious injury.**

### DANGER

#### TENSION DANGEREUSE

Avant de régler le cavalier J20 :

- Coupez toute source d'alimentation.
- Attendez une minute que la décharge des condensateurs du bus CC s'effectue.

**Si cette directive n'est pas respectée, cela entraînera la mort ou des blessures graves.**

J20 is a pin-jumper selector located below the terminal block on the left side of the control board (see Figure 9 on page 17 and Figure 10 on page 18). It has seven positions and three movable shorting jumpers:

- The left-most set selects the VIN1 analog speed reference.
- The middle set selects the VIN2 analog speed reference.
- The right-most set selects whether pull-up or pull-down logic is employed.

See the following page for information on where to place each of the three jumpers for your requirements. A pair of small needlenose pliers is useful for moving these jumpers.

## Section 4: Connections

### VIN1 Analog Reference Selection (24-FSEL selects direct or inverse operation)

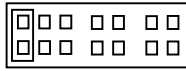

This placement configures the inverter to accept an external 0-10 VDC speed reference signal for VIN1. Input impedance is 95 k $\Omega$ .

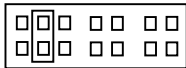

This placement configures the inverter for either a 0-20 mA or a 4-20 mA input for VIN1 (0 or 4 mA is selected by 24-SEL). Input impedance is 250 k $\Omega$ .

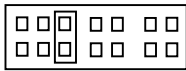

This placement is the default setting for VIN1; it configures the inverter for an external 0-5 VDC signal, or a speed potentiometer powered from the REF terminal on the control terminal strip. Input impedance is 48 k $\Omega$ .

### VIN2 Analog Reference Selection (24-FSEL selects direct or inverse operation)

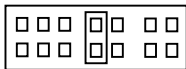

This placement configures the inverter to accept an external 0-10 VDC speed reference signal for VIN2. Input impedance is 95 k $\Omega$ .

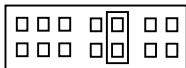

This placement is the default setting for VIN2; it configures the inverter for an external 0-5 VDC signal. Input impedance is 48 k $\Omega$ .

### Digital Input Logic Selection

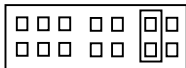

This placement configures the digital inputs for pull-down logic (that is, active when connected to terminal CM). Inputs are high, and are pulled low to activate.

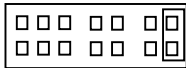

This placement is the default setting; it configures the digital inputs for pull-up logic (that is, active when connected to terminal V+ or to an external power supply with its common connected to CM). Inputs are low and require a positive voltage to activate them. 0-3 VDC is **inactive**; 10-24 VDC is **active**.

## 4.5 J22 Option Connector

Connector J22, located on the right side of the X2C inverter, is used to interface with a number of external options (see Section 10 starting on page 87 for further information). Keypad options interfaced through J22 may be mounted up to 300 feet (91.44 m) from the inverter.

Programmer options allow storage of up to ten separate parameter sets.

## 4.6 Input Line Requirements

### A. Line Voltage

Refer to Tables 6 and 7 on page 9 for allowable AC line voltage fluctuation. A supply voltage above or below these limits will cause the inverter to trip with either an overvoltage or an undervoltage fault.

When applying the inverter to line voltages other than the factory default values (230 VAC or 460 VAC), be sure to set parameter 59-MVOLT to the proper value. See page 60.

Use caution when applying E-trAC X2C inverters on low line conditions. For example, an E-trAC X2C 2000 series inverter will operate properly on a 208 VAC line; however, the maximum output voltage will be limited to 208 VAC. If the motor is rated for 230 VAC line voltage, higher motor currents and increased heating will result. Ensure that the voltage rating of the motor matches the applied line voltage. If other than 60 Hz output is desired, proper volts/Hertz can be programmed into the inverter by the 53-FKNEE and 32-FMAX parameters. If you are unsure about this feature, consult the factory.

### B. Line Capacity

If the source of AC power to the inverter is greater than 10 times the kVA rating shown in Table 12, an isolation transformer or line inductors are recommended. Consult the factory for help in sizing the inductors.

*NOTE: E-trAC X2C inverters are suitable for use on a circuit capable of delivering not more than 5000 rms symmetrical amperes at 10% above maximum rated voltage.*

### C. Phase Imbalance

Phase voltage imbalance of the input AC source can cause unbalanced currents and excessive heat in the inverter's input rectifier diodes and DC bus capacitors. Phase imbalance can also damage motors running directly across the line.

**Table 12: Input Power Transformer Ratings**

Rated Horsepower	0.5	1.0	2.0	3.0	5.0	7.5	10	15	20
Minimum kVA Rating	1.0	2.0	4.0	5.0	8.0	12.7	17.7	24.7	30.2

## Section 4: Connections

### CAUTION

#### EQUIPMENT DAMAGE HAZARD

Never use power-factor correction capacitors on motor terminals M1, M2, and M3 of the E-trAC X2C inverter. Doing so will damage the semi-conductors.

**Failure to follow this instruction can result in injury or equipment damage.**

### ATTENTION

#### RISQUE DE DOMMAGES MATÉRIELS

N'utilisez jamais les condensateurs d'amélioration du facteur de puissance sur les bornes de moteur M1, M2 et M3 de l'onduleur ACP3. Cela endommagera les semi-conducteurs.

**Si cette directive n'est pas respectée, cela peut entraîner des blessures corporelles ou des dommages matériels.**

#### D. Single Phase Operation of 0.5 to 5 HP Inverters

0.5 to 5 HP X2C2000 inverters are designed for both three-phase and single-phase input power. If operating with single-phase power, use line terminals L1 and L2. The output of the inverter will always be three phase. See Table 6 on page 9 for applicable derating when using single-phase input power. See page 25 for proper power connections. Do not connect single-phase motors to the inverter output terminals M1, M2, or M3.

### 4.7 Line Protection

It is necessary to provide either a circuit breaker or a fused disconnect switch on the input AC line in accordance with all applicable electrical codes. The following rules should be used to select the correct size of the input line fuses or circuit breaker.

#### A. Fuse Sizing and Type

The X2C inverter is able to withstand a 150% overload for 60 seconds. For maximum protection of the inverter, use the fuses listed in Table 13. Recommended suppliers are Bussmann for 230 VAC and 460 VAC

installations. Equivalent fuses from other manufacturers may be substituted.

**Table 13: Recommended Fuses**

Model Number	Fuse	Model Number	Fuse
X2C1000-5x	KTK-7 or KTK-R-7	X2C2020-0x	JKS-125
X2C1001-0x	KTK-15 or KTK-R-15	X2C4001-0x	KTK-4 or KTK-R-4
X2C2000-5x	KTK-3 or KTK-R-3	X2C4002-0x	KTK-7 or KTK-R-7
X2C2001-0x	KTK-10 or KTK-R-10	X2C4003-0x	KTK-10 or KTK-R-10
X2C2002-0x	KTK-15 or KTK-R-15	X2C4005-0x	KTK-15 or KTK-R-15
X2C2003-0x	KTK-25 or KTK-R-25	X2C4007-5x	KTK-25 or KTK-R-25
X2C2005-0x	KTK-40	X2C4010-0x	KTK-35
X2C2007-5x	KTK-50 or JKS-50	X2C4015-0x	KTK-50 or JKS-50
X2C2010-0x	JKS-60	X2C4020-0x	JKS-60
X2C2015-0x	JKS-100		

## 4.8 Wiring

### A. Applicable Codes

All E-trAC X2C Series inverters are Underwriters Laboratories, Inc. (UL) and Canadian Underwriters Laboratories (cUL) listed and therefore comply with the requirements of the National Electrical Code (NEC) and the Canadian Electrical Code (CEC). Installations intended to meet UL and cUL requirements must follow the instructions provided in “General Wiring Practices” section below as a minimum standard. Where local codes exceed these requirements, they must also be followed. Refer to the technical data label affixed to the inverter and the motor nameplate for electrical data.

### B. General Wiring Practices

When making power and control connections, observe these precautions:

- Never connect input AC power to the motor output terminals M1, M2 and M3 or damage to the inverter will result.
- Power wiring to the motor must have the maximum possible separation from all other power wiring. Do not run in the same conduit; this separation reduces the possibility of coupling electrical noise between circuits.
- Cross conduits at right angles whenever power and control wiring cross.

## Section 4: Connections

- Good wiring practice also requires separation of control circuit wiring from all power wiring. Since power delivered from the inverter contains high frequencies which may cause interference with other equipment, do not run control wires in the same conduit or raceway with power or motor wiring.

### C. Power Wiring

Power wiring refers to the line and load connections made to terminals L1, L2, L3, and M1, M2, M3 respectively. See Figure 9 on page 17 and Figure 10 on page 18 for power terminal locations. Select power wiring as follows:

1. Use only UL recognized wire.
2. Wire voltage rating must be a minimum of 300 V for 230 VAC systems, and 600 V for 460 VAC systems.
3. Wire must be shielded and of copper construction. Refer to Table 14 for recommended wire gauges and temperature ratings.
4. Grounding must be in accordance with NEC and CEC.
5. For 0.5 to 5 HP models, incoming power (L1, L2, L3 or L1, L2 for single-phase) **must** run through the ground fault CT, which is located towards the bottom of the enclosure. The ground conductor, however, should **not** run through the ground fault CT. See Figure 9 on page 17 for further information.

**Table 14: Recommended Wire Gauges**

Model Number	AWG Size	Temperature Rating (°C)	Model Number	AWG Size	Temperature Rating (°C)
X2C1000-5x	14	60/75	X2C4001-0x	14	60/75
X2C1001-0x	14	60/75	X2C4002-0x	14	60/75
X2C2000-5x	14	60/75	X2C4003-0x	14	60/75
X2C2001-0x	14	60/75	X2C4005-0x	14	60/75
X2C2002-0x	14	60/75	X2C4007-5x	14	60/75
X2C2003-0x	14	60/75	X2C4010-0x	12	60/75
X2C2005-0x	12	60/75	X2C4015-0x	8	60/75
X2C2007-5x	8	60/75	X2C4020-0x	8	60/75
X2C2010-0x	6	60/75			
X2C2015-0x	6	90			
X2C2020-0x	6	90			

**D. Control Wiring**

Control wiring refers to the wires connected to the control terminal strip (20 terminals). Select control wiring as follows:

1. Shielded wire is recommended to prevent electrical noise interference from causing improper operation or nuisance tripping. Connect the shield to terminal CM on the control terminal strip only.
2. Use only UL recognized wire.
3. Wire voltage rating must be a minimum of 300 V for 230 VAC systems, and 600 V for 460 VAC systems (Class 1 wire).

**4.9 Reducing Current Surges and Voltage Transients**

Inrush currents to the coils of magnetic contactors, relays and solenoids associated with, or in close proximity to, the inverter can induce high current spikes in the power and control wiring, causing faulty inverter operation. If this condition occurs, a snubber network, consisting of a series resistor and capacitor for AC loads, or a free-wheeling or flyback diode for DC loads, should be placed across the relay coil.

For 115 VAC loads, TB Wood's part number U4785, or ITW Quencharc part number #104M06QC150 is suitable.

For magnetic contactors, relays and solenoids which are energized from a DC source, a free-wheeling diode should be used. The diode should be a high-speed, fast recovery type. Connect the diode across the coil with the cathode end toward the positive power source. The diode current and voltage should be selected by the following formulae:

$$\text{Diode Current Rating (A)} \geq \frac{\text{Coil Capacity (VA)}}{\text{Rated Voltage of Coil (V)}}$$

$$\text{Diode Voltage Rating} \geq \text{Rated Voltage of Coil (V)} \times 2$$

## Section 4: Connections

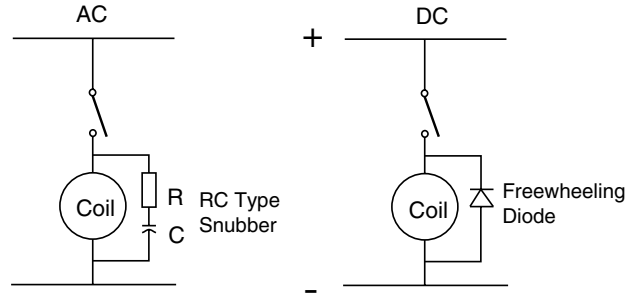

Figure 11: Snubber and Diode

### 4.10 Connection Diagrams

Figures 12 through 22 show some of the commonly used connections for operating the E-trAC X2C inverter from external devices. Refer to Section 4.2 on page 17 for a description of the control input terminals.

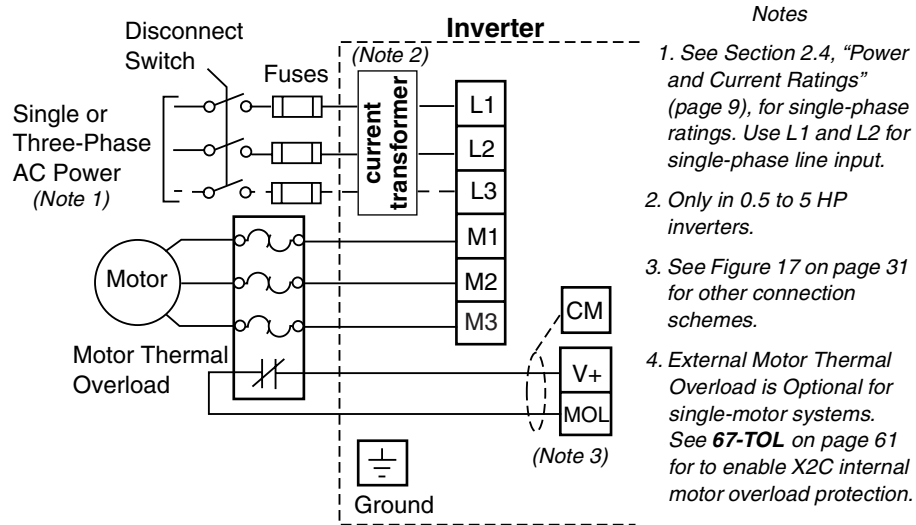

Figure 12: AC Line and Motor Connections

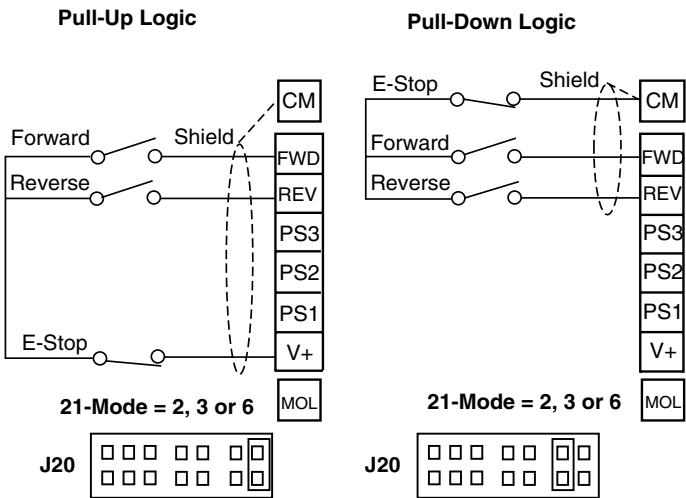

Figure 13: 2-Wire Run/Stop Connections

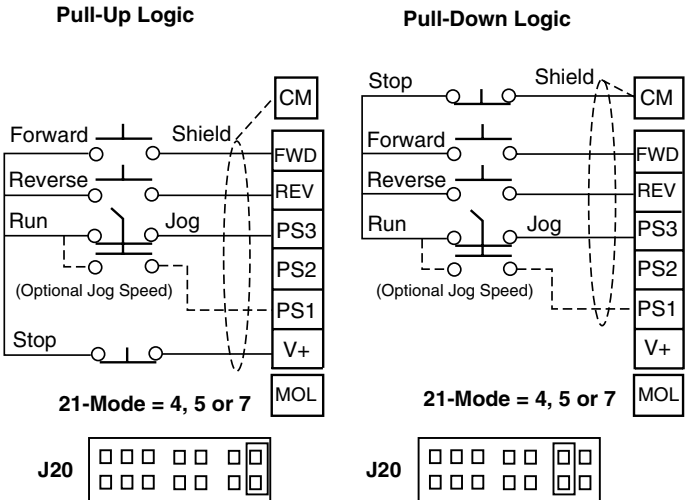
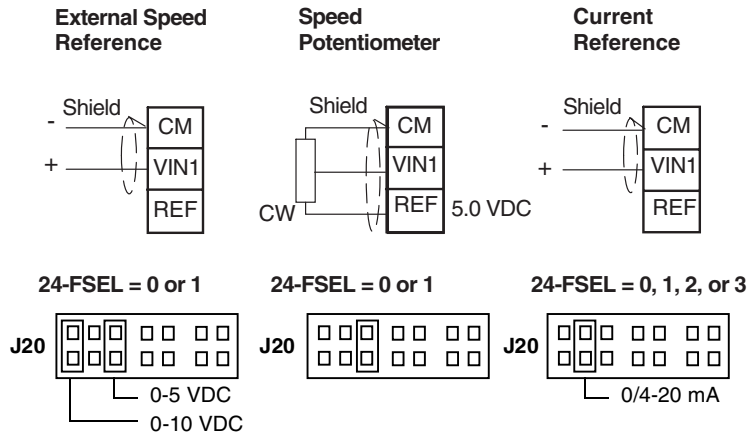

Figure 14: 3-Wire Run/Stop Connections

**Section 4: Connections**



*Note: 21-MODE = 1, 3, 5, or 11*

**Figure 15: VIN1 Analog Speed Input Connections**

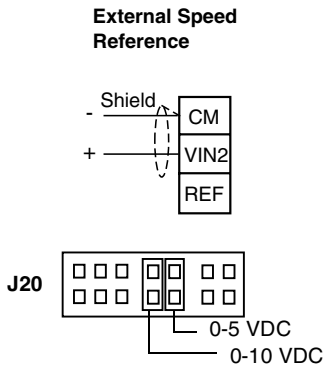

*Note: 21-MODE = 1, 3, 5, or 11*

**Figure 16: VIN2 Analog Speed Input Connections**

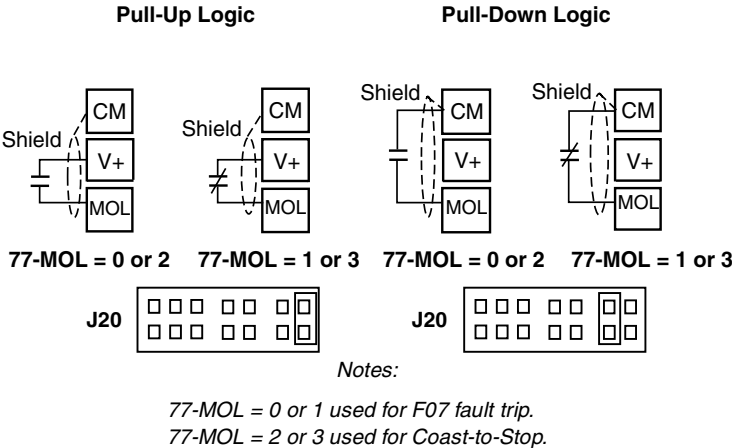

Figure 17: MOL Terminal Connections

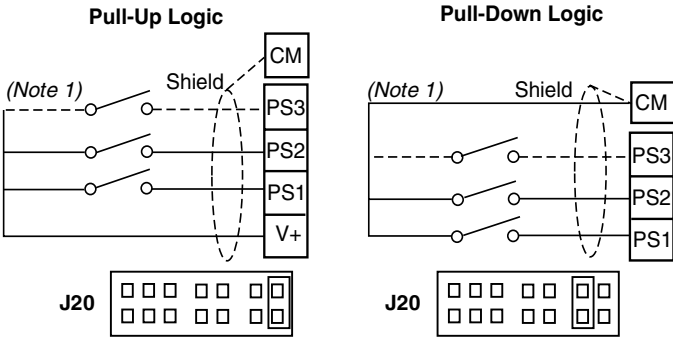
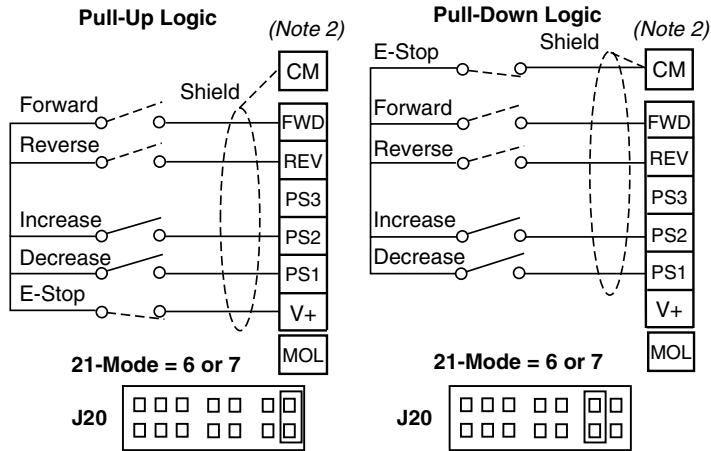
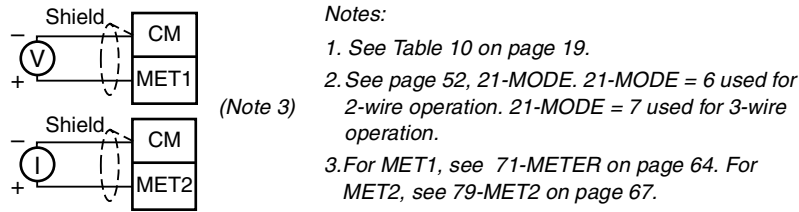

Figure 18: Preset Speed Selection

**Section 4: Connections**



**Figure 19: EMOP Selection**



**Figure 20: Analog Meter**

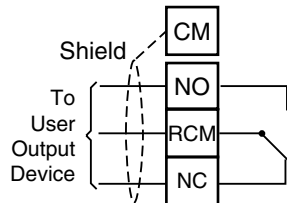

**Figure 21: Relay STR**

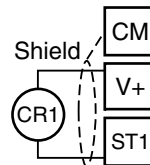

**Figure 22: Logic Output ST1**

---

## Section 5: RFI Suppression and XLF Line Filters

### 5.1 Introduction

This section contains specifications, installation, and operation instructions for TB Wood's XLF Series line filters. Proper installation of the XLF Series filters in the correct model of X2C Series inverter will aid in complying with CE (Conformité Européen) EMC directives. These filters limit emissions per EMC Directive 89/336 EEC to meet the following specifications:

**Table 9: EMA (Electromagnetic Emission) Specifications**

EN 50081-1	Basic specification, "Emitted Interference"
EN 55011	Emitted Interference - Industrial, Scientific and Medical Installations
EN 55014	Emitted Interference - Residential Installations

**Table 10: EMB (Electromagnetic Interference) Specifications**

EN 50082-2	Basic specification, "Interference Immunity"
EN 50140	Electromagnetic Fields
EN 60801	Static Discharge
ENV 50142	Surge
IEC 801-4	Burst on mains lead/data line

To ensure compliance with the CE directive, observe the following procedures:

1. Install a line filter on a properly-matched X2C inverter.
2. To meet the B Curve for EMC (commercial) compliance, an output reactor may also be required. No output filter or reactor is required to meet the A Emission Curve for EMC (Industrial) compliance (reduces leakage current to a level below 3.5 mA).
3. Install shielded motor cable and correctly ground the shield.
4. Observe general RFI suppression measures. Refer to "Interference Suppression Measures," on pages 38-40.

*NOTE: Although the filters have been tested with the inverters for compliance, installation practices and other wiring concerns make CE compliance with EMC directives the responsibility of the installer of the equipment. In addition, motor output wiring considerations required to meet the CE directives are presented in "Interference Suppression Measures" on pages 38 to 40. XLF Series line filters are not UL listed or recognized. If local codes permit, the filters may be used in the United States as a solution for EMI and RFI problems either caused by or affecting the operation of an X2C series inverter.*

## Section 5: RFI Suppression and XLF Line Filters

### 5.2 XLF Series Filter Specifications

All TB Wood's line filters are provided in IP20 enclosures. They can operate over a temperature range of -10 to +50 °C (-23 to +122 °F). The filters can be mounted parallel or perpendicular to the control panel. The filter is supplied with the correct mounting hardware for mounting the inverter on top of the filter enclosure. See Table 11 for XLF filter model numbers.

**Table 11: XLF Series Filters Model Numbers**

Filter Model Number	V	Phase	A	HP	kW	Leakage	For Use With
XLF20005	230	1	5	0.75	0.5	5 mA	X2C20005x X2C20010x
XLF20020	230	1	10	1.5	1.1	5 mA	X2C20020x
XLF20050	230	1	20	3.0	2.2	5 mA	X2C20030x X2C20050x
XLF40010	460	3	3	1.0	0.7	5 mA	X2C40010x
XLF40020	460	3	5	3.0	2.2	5 mA	X2C40020x
XLF40050	460	3	12	5.0	3.7	5 mA	X2C40030x X2C40050x
XLF40200	460	3	38	20	15	5 mA	X2C40075B to X2C40200B

5.3 XLF Series Filter Dimensions

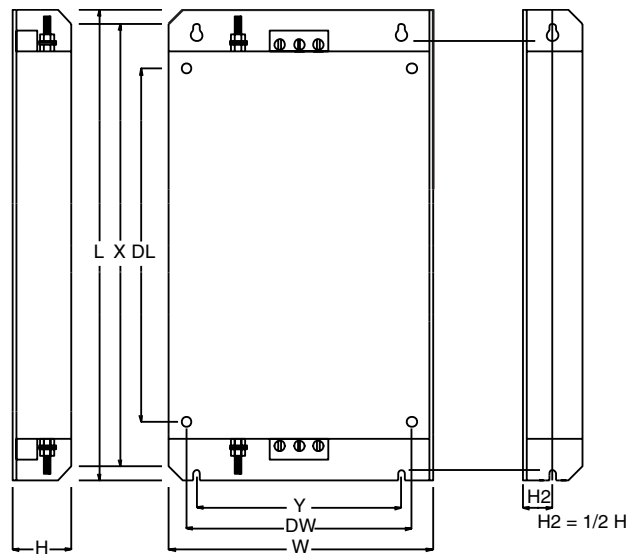

Table 12: XLF Filter Dimensions: in. (mm)

Model	Case Dimensions			Case Mounting			Inverter Mounting			Terminals	
	L	W	H	X	Y	Size	DL	DW	Size	Lines	GND
XLF20005	7.87 (200)	4.25 (108)	1.57 (40)	7.20 (183)	3.15 (50)	M5	5.39 (137)	3.70 (94)	M5	AWG 13	M4
XLF20020	7.87 (200)	5.71 (145)	1.57 (40)	7.20 (183)	4.33 (110)	M5	5.39 (137)	5.08 (129)	M5	AWG 13	M4
XLF20050	9.84 (250)	5.71 (145)	1.77 (45)	9.25 (235)	4.33 (110)	M5	7.40 (188)	5.08 (129)	M5	AWG 13	M5
XLF40010	7.87 (200)	4.25 (108)	1.57 (40)	7.20 (183)	3.15 (80)	M5	5.39 (137)	3.70 (94)	M5	AWG 13	M4
XLF40020	7.87 (200)	5.71 (145)	1.57 (40)	7.20 (183)	4.33 (110)	M5	5.39 (137)	5.08 (129)	M5	AWG 13	M4
XLF40050	9.84 (250)	5.71 (145)	1.77 (45)	9.25 (235)	4.33 (110)	M5	7.40 (188)	5.08 (129)	M5	AWG 13	M5
XLF40200	14.17 (360)	8.74 (222)	1.97 (50)	13.46 (342)	6.30 (160)	M6	11.02 (280)	7.87 (200)	M6	AWG 6	M5

## 5.4 Installing XLF Line Filters

### A. Receiving Filters

Upon receipt of the filter, unpack it and carefully inspect for any damage sustained in transit. If damage is apparent, notify your freight or express agent within 15 days of receipt of the product, request that he inspect the merchandise, then file a claim against the carrier. Save the box and packing material and contact TB Wood's Incorporated immediately.

### B. Mounting Filters

TB Wood's XLF Series line filters are designed to mount directly to a flat surface such as an enclosure panel. Metal hardware should be used to ensure that the case of the filter is at earth ground potential ("PE"). The filters can be mounted parallel to the panel or perpendicular to the panel.

Install the filter as close as possible to the inverter. When mounting the filters parallel to the panel, the inverter can be mounted to the top of the filter module with the hardware provided (see Figure 7).

### C. Connecting Filters

*NOTE: Additional connection requirements may be necessary, depending on CEC, CE, VDE, or local codes.*

Figure 8 shows the connections required for compliance to the CE EMC directive. Due to the leakage current associated with these filters (> 3.5 mA), one of the following measures must be taken to be in

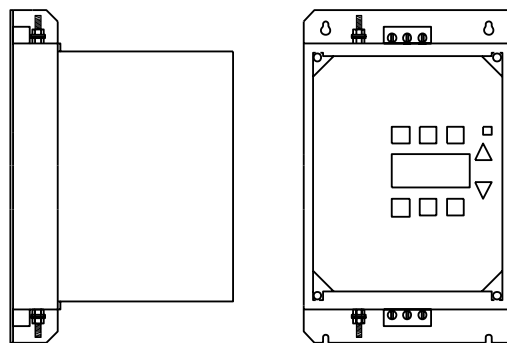
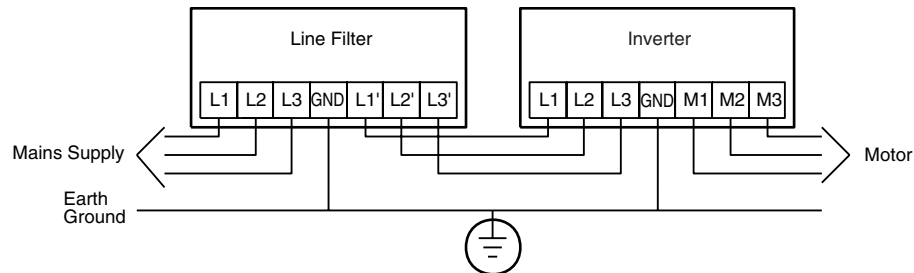

Figure 7: Mounting Inverter to Filter Module

## Section 5: RFI Suppression and XLF Line Filters



**Figure 8: Line Filter Connections**

compliance with specification EN 50178:

1. The filter must be connected by a cable which is electrically parallel with the earth ground conductor. This conductor must meet the requirements of IEC 364-5-543 on its own.
2. The ground conductor must have a cross section of at least 10 mm<sup>2</sup> (6 AWG).
3. The ground conductor must be monitored by a fault detection device that isolates the inverter from the power source in the event of a fault.

The inverter must always be connected permanently (EN 50178) when using an XLF Series line filter, due to the leakage currents involved.

See Table 13 for wire sizing requirements.

**Table 13: Line Filter Wire Gauges**

Model	Line Conductor	Ground Conductor
XLF20005	12 AWG, 300 V	6 AWG, 300 V
XLF20020	12 AWG, 300 V	6 AWG, 300 V
XLF20050	12 AWG, 300 V	6 AWG, 300 V
XLF40010	12 AWG, 600 V	6 AWG, 600 V
XLF40030	12 AWG, 600 V	6 AWG, 600 V
XLF40050	12 AWG, 600 V	6 AWG, 600 V
XLF40200	6 AWG, 600 V	6 AWG, 600 V
WLF40050	12 AWG, 600 V	6 AWG, 600 V
WLF40200	6 AWG, 600 V	6 AWG, 600 V

### 5.5 Interference Suppression Measures (Electromagnetic Compatibility)

Electrical/electronic devices are capable of influencing or disturbing each other through connecting cables or other metallic connections. Electromagnetic compatibility consists of two elements: interference resistance and interference emission.

Correct installation of the inverter in conjunction with any possible local interference suppression measures has a crucial effect on minimizing or suppressing mutual interference.

The following guidelines assume a power source that is not contaminated by high frequency interference. Other measures may be necessary to reduce or suppress interference if the power source is contaminated, and no general recommendations can be given for such cases. Please consult TB Wood's Electrical Application Engineering Department if the following recommended interference suppression measures do not produce the desired result.

When dealing with RFI (radio frequency interference), the surface area of the conductors is a more critical consideration than its cross sectional area. Since high frequency interference does not flow through the entire cross section of the conductor, but tends to stay toward its outer surface (skin effect), braided copper tapes of equal cross section should be used.

The inverter and all components used for interference suppression, particularly the shield of the motor cable, should be connected over as large a surface area as possible when passing over metallic surfaces. Remove the paint from contact surfaces to ensure a good electrical connection. See Figure 9 for recommended connection technique.

A central grounding point should be used for interference suppression. Route the ground cables radially from this point, avoiding loops which may lead to interference.

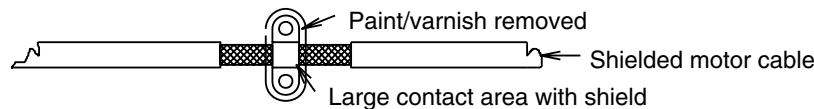

Figure 9: Recommended Connection Technique

## Section 5: RFI Suppression and XLF Line Filters

Take care not to damage the shield cross section when connecting it to the continuing lines. This raises the RF resistance of the shield and radiates rather than discharges the RF energy traveling on the shield. Shields, particularly those on control cables, must not be routed through pin contacts (plug connectors). When shielded cables must pass through a plug connection, use the metallic hand guard of the plug for the continuation of the shield. It is strongly recommended that the shield be uninterrupted whenever possible.

Use a shielded motor cable which is grounded over a large surface area at both ends. The shield on this cable should be uninterrupted. If a shielded motor cable cannot be used, the unshielded motor line should be laid in a metal conduit or duct which is uninterrupted and grounded at both ends.

When selecting shielded cable for use as motor leads, it is important to select a cable which is designed for operation at the frequencies and power levels involved. Improper selection of motor cable can cause high potential to exist on the shield. This could cause damage to the inverter and other equipment, and could pose a safety hazard. The following cables are acceptable for this purpose:

- OLFlex<sup>1</sup> Series 150CY, 110CY, 110CS, 100CY, 100CS, and 540CP
- Siemens<sup>2</sup> Cordaflex<sup>SM</sup>

If the installation requires the use of an output reactor, the reactor, like the line filter, should be placed as close as possible to the inverter.

Some of these cables are VDE approved only; others carry VDE, UL, CSA, and combinations of these ratings. Be sure to confirm that the cable you are using meets the certification of the agency required.

Control wires longer than 3 feet must be run in shielded cable, and the shield must be terminated at common (CM) on the inverter. Note that connection to CM, the circuit common, rather than earth ground, is allowed because X2C inverters have isolated control inputs. If the signal run exceeds 30 feet, a 0-20 mA or 4-20 mA signal should be used, as it will have better noise immunity than a low level voltage.

---

1. OLFlex Wire & Cable, 30 Plymouth Street, Fairfield, NJ 07004 (800) 774-3539.

2. Siemens Energy and Automation, Inc., Power Cables, 3333 State Bridge Road, Atlanta, GA 30202 (800) 777-3539.

## Section 5: RFI Suppression and XLF Line Filters

Other loads connected to the power source may produce voltage transients (spikes) that may interfere with or damage the inverter. Line reactors or filters can be used on the input power to protect the inverter from such transients.

If the inverter is operated from switchgear devices or is in close proximity to switchgear devices (in a common cabinet), the following procedures are recommended as a precaution to prevent these devices from interfering with the inverter's operation:

- Wire the coils of DC devices with freewheeling diodes. The diodes should be placed as close as possible to the physical coil of the device.
- Wire the coils of AC devices with RC type snubber networks. Place the snubbers as close as possible to the physical coil of the device.
- Use shielded cables on all control and monitoring signals.

Route distribution cables (for example, power and contactor circuits) separately and as far away from control and monitoring signal cables as possible.

---

## Section 6: Getting Started

### 6.1 Introduction

The E-trAC X2C AC inverter is pre-programmed to run a standard, 4-pole AC induction motor. For many applications, the inverter is ready for use right out of the box with no additional programming. The digital keypad controls all operations of the inverter. The eight input keys allow “press and run” operation of the motor (Operation mode) and straightforward programming of the parameters (Program mode).

To simplify programming, the parameters are grouped into two levels:

1. Level 1 is entered by pressing the Program (PROG) key at any time. Level 1 allows you to access the most commonly used parameters.
2. Level 2 is entered by holding down the SHIFT key while pressing the PROG key. Level 2 allows access to all inverter parameters, including those in Level 1, for applications which require more advanced features.

Some E-trAC X2C inverters do not include a keypad as standard equipment. These models are programmed to operate through the control terminal strip. They may be re-programmed using the options described in Section 10, “Options and Replacement Parts.”

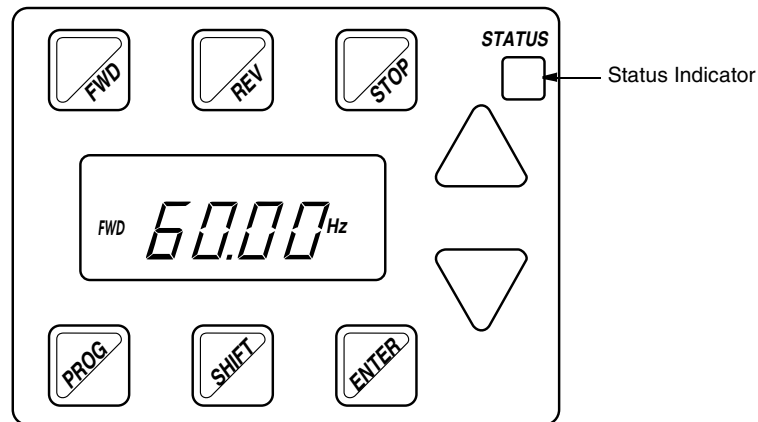

Figure 10: Digital Keypad

## Section 6: Getting Started

### 6.2 Keypad Operation





Parameter 21-MODE (see page 52) determines whether the inverter accepts its Run/Stop and speed commands from the digital keypad or from the input terminals. When 21-MODE is set to 0 or 10, Run/Stop and speed commands are accepted from the keypad. Table 14 describes the function of the keys in Operation mode.

**Table 14: Function of Keys in Operation Mode (Inverter Running or Stopped)**

	Initiates forward run when pressed momentarily. If the inverter is running in reverse when FWD is pressed, it will decelerate to zero speed, change direction, and accelerate to the set speed.
	Initiates reverse run when pressed momentarily. If the inverter is running in forward when REV is pressed, it will decelerate to zero speed, change direction, and accelerate to the set speed.
	Causes a Ramp-to-Stop when pressed. Programmable to Coast-to-Stop by parameter 41-RSEL (page 55).
	When the inverter is stopped, pressing this key increases the desired running speed. When the inverter is running, pressing this key increases the actual running speed. Setting resolution is 0.05 Hz up to 99.95 Hz, and 0.1 Hz above this frequency. The display scrolls at an increased rate after holding the key for five seconds. Pressing SHIFT while holding the key bypasses the delay.
	When the inverter is stopped, pressing this key decreases the desired running speed. When the inverter is running, pressing this key decreases the actual running speed. Setting resolution is 0.05 Hz up to 99.95 Hz, and 0.1 Hz above this frequency. The display scrolls at an increased rate after holding the key for five seconds. Pressing SHIFT while holding the key bypasses the delay.
	When the inverter is stopped or running, pressing this key stores the selected frequency as the initial operating frequency when the inverter is powered up. The frequency is maintained until another frequency is entered.
	When the inverter is running, pressing this key accesses the Level 1 parameters for viewing only. Holding down SHIFT and then pressing PROG accesses the Level 2 parameters for viewing. Any attempt to program (other than 70-MCAL) results in a display that shows "----". When the inverter is stopped, programming is allowed in both Level 1 and Level 2. See Table 15.

Program mode is entered by stopping the inverter and pressing the Program (PROG) key for Level 1 access; or holding down SHIFT while pressing PROG for Level 2 access. Table 15 describes the function of the keys in Program mode.

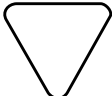
**Table 15: Function of Keys in Program Mode (Inverter Stopped)**

	<p>Pressing this key when the inverter is stopped enters the Program mode at Level 1. Pressing this key at any time while in the Program mode returns the inverter to the Operation mode. Pressing and holding SHIFT while pressing PROG accesses the Level 2 parameters. If an Access Code has been programmed, it must be entered to change Data Code. See 87-ACODE (page 71).</p>
	<p>In the Program mode, pressing this key scrolls forward through the parameters. If the PRG indicator is flashing, it increases the Data Code. The ENTER key must be pressed to store the Data Code.</p>
	<p>In the Program mode, pressing this key scrolls backward through the parameters. If the PRG indicator is flashing, it decreases the Data Code. The ENTER key must be pressed to store the Data Code.</p>
<p><i>NOTE: If the PRG indicator is flashing, momentarily pressing and releasing both the UP and DOWN arrows simultaneously will return the Data Code to factory defaults. Press ENTER to store the new code.</i></p>	
	<p>Pressing this key while a parameter is displayed allows that parameter to have its Data Code changed by use of the UP and DOWN arrow keys. The PRG indicator flashes to show that the parameter can be programmed.</p>
	<p>This key must be pressed after the Data Code has been changed to store the new code. The display will show “stored” (STO) for one second indicating that the Data Code has been entered into memory</p>

## Section 6: Getting Started

### 6.3 Status Indicator

The STATUS indicator consists of two LEDs, one green and one red, located in the upper right corner of the keypad (see Figure 10 on page 41). Table 16 defines STATUS indications for the various operating conditions of the inverter.

Table 16: Status Indicators

Status Indicator		Operating Condition
Color	Duration	
Green & Red	Continuous	Power on, restart (2 seconds)
Red	Continuous	Stop, running in torque limit
Green	Continuous	Run
Green & Red	Flashing	Running in and out of torque limit
Green	Flashing	Running in and out of an overvoltage or undervoltage condition
Red	Flashing	Inverter faulted, emergency stop, line start lockout, or low voltage

### 6.4 LCD Display

The back-lit, LCD display provides information on inverter operation and programming. The four large 7-segment displays show inverter output and programming data. The two smaller digits at the upper left corner indicate parameter numbers in the Program mode. Special symbols provide further information about inverter operation. Figure 11 shows all segments displayed. In normal operation, only active segments are displayed.

Table 17 on page 45 lists the LCD display's special annunciators and their meaning.



Figure 11: LCD Display

Table 17: Description of Displays

Symbol	Indication
FWD	Forward direction commanded
REV	Reverse direction commanded
PRG	Continuous: Program mode selected Flashing: Data Code may be changed
SET	Inverter is stopped, or is having the running frequency set
OV	Inverter is in an overvoltage condition
UV	Inverter is in an undervoltage condition
LIM	Inverter is running in torque limit
OC	Continuous: Inverter has tripped due to an overcurrent condition Flashing: Inverter is in an overcurrent condition
TEMP	Continuous: Inverter has tripped due to an overtemperature condition Flashing: Inverter is near an overtemperature condition
DB	The standard Dynamic Brake circuit is active
rpm	Revolutions per minute indication
Hz	Frequency in Hertz
h	Time in hours
s	Time in seconds
A	Output current in Amperes
V	Output voltage in Volts
%	Display is in percent of units
C	Degrees centigrade

## 6.5 Programming Tips

### A. Accessing Parameters

When PROG (or SHIFT-PROG) is pressed after the application of power or a fault reset, 21-MODE is always the first parameter displayed.

If a different parameter is accessed and Program mode is exited, that parameter is the first one displayed the next time Program mode is entered. The inverter remembers a different “last parameter accessed” for Levels 1 and 2.

If no key is pressed for 10 minutes while in the Program mode, the inverter automatically reverts to the operating mode.

## Section 6: Getting Started

### B. Changing Display Scroll Rate

Three scroll rates are used to speed data entry.

1. If either the UP or DOWN arrow is pressed and held for five seconds, the scroll rate will increase.
2. If the SHIFT key is momentarily pressed while pressing one of the arrow keys, the five-second delay will be bypassed.
3. If the SHIFT key is pressed a second time while pressing an arrow key, the display will scroll at the fastest rate.

### C. Restoring Factory Settings

Whenever a parameter Data Code is being changed (noted by PRG flashing) the original factory setting for that parameter can be restored by pressing and releasing both the UP and DOWN arrows simultaneously and then pressing the ENTER key.

To restore ALL parameters to factory settings, or to recall a previously stored parameter set, see 81-PRGNO (page 67).

### D. Getting Help

For application assistance, call TB Wood's Electrical Application Engineering Department at 888-TB WOODS (888-829-6637).

## 6.6 Quick Start

The following procedure is for operators with simple applications who would like to get up and running quickly. *Be sure to read and understand Sections 6.1 through 6.5 before proceeding with these instructions.* If you are using remote operators, substitute the speed potentiometer for the UP and DOWN arrows, and the remote Run/Stop switch for the FWD key in the following instructions.

### CAUTION

#### IMPROPER EQUIPMENT COORDINATION

Verify that proper voltage is connected to the inverter before applying power.

**Failure to observe this instruction can result in injury or equipment damage.**

### ATTENTION

#### MAUVAISE COORDINATION DES APPAREILS

Vérifiez que l'onduleur est raccordée à la bonne tension avant de le mettre sous tension.

**Si cette directive n'est pas respectée, cela peut entraîner des blessures corporelles ou des dommages matériels.**

1. Follow all precautions and procedures in Section 3, "Receiving and Installation."
2. Apply AC power to the input terminals. For about two seconds the display will show all segments active. (See Figure 11.) The STATUS indicator will then turn red indicating a Stop condition, and the display will change to the first indication in Figure 12.
3. The factory settings are for keypad only operation in the forward direction—that is, the REV key is disabled. Press the FWD key, and the display will change to the second indication in Figure 12.
4. Press the UP Arrow to increase the desired running frequency. When the display gets to 0.1 Hz, the inverter starts to produce an output.

## Section 6: Getting Started

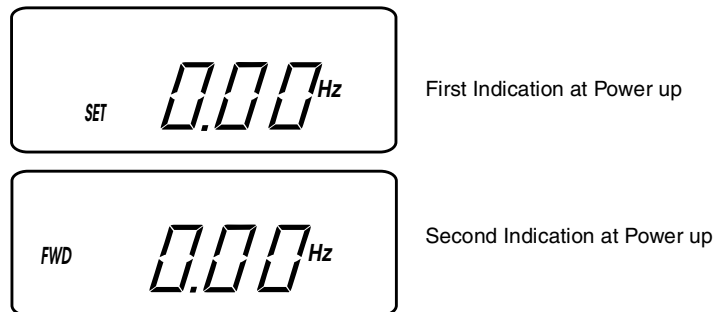

**Figure 12: Display at Power Up**

5. When the motor starts to turn, check the rotation. If the motor is turning in the wrong direction, *press STOP, remove AC power, and wait for all indicators to go out.* After the STATUS indicator has gone out, reverse any two of the motor leads at M1, M2 or M3.
6. The inverter is preset to run a typical NEMA B 4-pole induction motor to a maximum speed of 60.0 Hz with both acceleration and deceleration times set to 3.0 seconds.
7. Use the Arrow keys to set the proper running speed of the motor and the FWD and STOP keys to control its operation.

---

## Section 7: Parameter Configuration and Description

### 7.1 Programming

This section explains how to program the E-trAC X2C inverter parameters. See Section 6 on page 41 for an overview of the digital keypad operation.

To program the value of a parameter (refer to Figure 13):

1. Press the STOP key to stop the inverter if it is running.
2. Press the Program (PROG) key to enter Level 1 Program mode. To enter Level 2, press and hold the SHIFT key and then the PROG key. The PRG indicator will turn on.
3. Press the UP/DOWN arrow keys to access the desired parameter. The parameter number is displayed in the upper left corner of the digital display.
4. Press the SHIFT key to allow the data code to be changed. PRG starts to blink.
5. Press the UP/DOWN arrows to select the new data code.
6. Press the ENTER key to store the new data code. The display shows “Stored” (STO) for one second.
7. Press the PROG key to exit the Program mode, or the UP/DOWN arrows to select a new parameter.

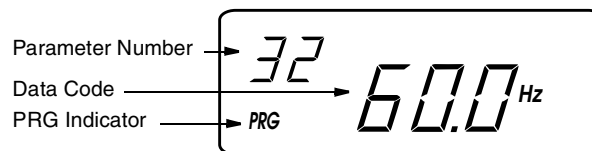

Figure 13: LCD Display

## Section 7: Parameter Configuration and Description

### 7.2 Parameter Descriptions

This section provides functional descriptions of all E-trAC X2C parameters. Setting resolution is 0.05 up to 99.95, and 0.1 above this point unless otherwise noted.

#### A. View-Only Parameters

The parameters shown in the table below may only be viewed, they cannot be programmed.

Parameter		Range or Units	Level	Description
02-RVLVL	Software Revision	—	L2	Displays main software revision level.
03-IRAT	Inverter Rated Current	A	L2	Defines the nominal output current of the inverter and serves as the 100% reference for all current measurements. The parameter's value varies by model; see Table 18. Continuous inverter capacity is 1.1 times 03-IRAT.
07-FLT3	Last Fault	—	L1	Defines the most recent faults. The two left-most digits are the fault code, and the right-most is elapsed time in 0.1 hr increments, since the last restart of the inverter, 0.9 hours max. See "Fault Trip Indications" on page 84.
08-FLT2	Second Fault	—	L2	
09-FLT1	First Fault	—	L2	
12-FOUT	Motor Output Frequency	0-400 Hz	L1	Inverter output frequency applied to the motor.
13-VOUT	Motor Output Voltage	0-100 %	L1	Motor output voltage calculated as a percent of applied line input voltage.
14-IOUT	Motor Output Current	0-60 A	L1	Motor phase current computed to an accuracy of $\pm 20\%$ .
15-LOAD	Inverter Load	0-200% of 03-IRAT	L1	True part of motor current. Output current measurement with motor power factor applied. Accuracy is $\pm 20\%$ . Load reading is positive in motoring mode, and negative in regenerative mode.
17-TEMP	Inverter Temperature	0-110 °C	L1	Inverter heat sink temperature. The inverter will turn off when this temperature exceeds its maximum allowed temperature. Accuracy is $\pm 3^\circ\text{C}$ .

**Section 7: Parameter Configuration and Description**

**Table 18: Values of Parameter 03-IRAT**

<b>Model Number</b>	<b>Value of 03-IRAT</b>	<b>Model Number</b>	<b>Value of 03-IRAT</b>
X2C1000-5	2.0 A	X2C4001-0	2.0 A
X2C1001-0	3.6 A	X2C4002-0	3.7 A
X2C2000-5	2.0 A	X2C4003-0	5.5 A
X2C2001-0	3.6 A	X2C4005-0	9.0 A
X2C2002-0	6.8 A	X2C4007-5	13.0 A
X2C2003-0	9.6 A	X2C4010-0	18.0 A
X2C2005-0	15.2 A	X2C4015-0	24.0 A
X2C2007-5	22.0 A	X2C4020-0	30.0 A
X2C2010-0	28.0 A		
X2C2015-0	42.0 A		
X2C2020-0	54.0 A		

## Section 7: Parameter Configuration and Description

### B. Programmable Parameters

The parameters on the following pages may be programmed as well as viewed.

21-MODE (Input Mode)		Default = 0	Level = L1
This parameter defines the source for speed reference and Run/Stop control input.			
Data Codes	Speed Control Source	Run/Stop Control	
0	Keypad	Keypad (Forward only)	
1	VIN Terminals	Keypad (Forward only)	
2	Keypad	Terminals (2-wire maintained contact)	
3	VIN Terminals	Terminals (2-wire maintained contact)	
4	Keypad	Terminals (3-wire momentary, RUN/JOG via PS3)	
5	VIN Terminals	Terminals (3-wire momentary, RUN/JOG via PS3)	
6	EMOP <sup>[1]</sup>	Terminals (2-wire, see Figure 19 on page 32)	
7	EMOP <sup>[1]</sup>	Terminals (3-wire, see Figure 19 on page 32)	
8	EMOP <sup>[2]</sup>	Terminals (2-wire, see Figure 19 on page 32)	
9	EMOP <sup>[2]</sup>	Terminals (3-wire, see Figure 19 on page 32)	
10	Keypad	Keypad (Forward and Reverse)	
11	VIN Terminals	Keypad (Forward and Reverse)	

1. Commanded output frequency returns to 31-FMIN when inverter is stopped.
2. Commanded output frequency remains at the previous setpoint when inverter is stopped. Control terminal logic for EMOP and EMOP1 is identical; see Table 19 below.

**Table 19: EMOP and EMOP1 Control Terminal Logic**

Description	FWD	REV	PS1	PS2
STOP	0	0	<i>ignored</i>	<i>ignored</i>
Speed = 0	1	1	<i>ignored</i>	<i>ignored</i>
FWD Decrease	1	0	1	<i>ignored</i>
FWD Hold	1	0	0	0
FWD Increase	1	0	0	1
REV Decrease	0	1	1	<i>ignored</i>
REV Hold	0	1	0	0
REV Increase	0	1	0	1

## Section 7: Parameter Configuration and Description

<b>24-FSEL (Speed Setpoint Selector)</b>	<b>Default = 0</b>	<b>Level = L2</b>
--	--------------------	-------------------

Data codes 0 – 3 select the speed setpoint characteristics and any offset required for input signal VIN1. See the discussion of J20 configuration on page 21 for additional information.

Data codes 4 – 7 define the reference input signal as VIN1 + VIN2.

Data codes 8 – 11 define the reference input signal as VIN1 – VIN2.

Data codes 12 – 15 allow auto/manual switch between VIN1 and VIN2.

If PS3=0, then the reference is VIN1 (auto); if PS3=1, then the reference is VIN2.

<i>Data Codes</i>	<i>Operation<sup>1)</sup></i>	<i>Offset</i>	<i>Input Signal VIN1</i>
0, 4, 8, 12	Direct	None	0-10 VDC, 0-5 VDC, 0-20 mA
1, 5, 9, 13	Inverse	None	0-10 VDC, 0-5 VDC, 0-20 mA
2, 6, 10, 14	Direct	20%	4-20 mA
3, 7, 11, 15	Inverse	20%	4-20mA

1. Direct is defined as maximum output (32-FMAX) at maximum input; inverse is defined as minimum output (31-FMIN) at maximum input.

<b>31-FMIN (Minimum Frequency)</b>	<b>Default = 0 Hz</b>	<b>Level = L1</b>
------------------------------------	-----------------------	-------------------

This parameter sets the minimum frequency to the motor. The frequency may range between 0 and 400 Hz.

<b>32-FMAX (Maximum Frequency)</b>	<b>Default = 60 Hz</b>	<b>Level = L1</b>
------------------------------------	------------------------	-------------------

Sets the maximum frequency to the motor, which may range between 20 and 400 Hz.  
**Consult motor manufacturer if frequency is in excess of nameplate rating.**

## Section 7: Parameter Configuration and Description

<b>33-F2 through 38-F7 (Preset Frequencies)</b>	<b>Default values are shown below</b>	<b>Level = L2</b>
---	---	-------------------

One of these six preset frequencies are selected with input terminals PS1, PS2, and PS3. (For further information, see the section on control terminals on page 19 and Figure 18 on page 31.) Note that any of these parameters may be set to a frequency greater than 32-FMAX, but the output will not exceed 32-FMAX when running. **Consult motor manufacturer if frequency is in excess of motor nameplate rating.**

<i>Parameter</i>	<i>Name</i>	<i>Range</i>	<i>Default Value</i>
33-F2	Preset Frequency 1	0 to 400 Hz	5 Hz
34-F3	Preset Frequency 2	0 to 400 Hz	20 Hz
35-F4	Preset Frequency 3	0 to 400 Hz	40 Hz
36-F5	Preset Frequency 4	0 to 400 Hz	60 Hz
37-F6	Preset Frequency 5	0 to 400 Hz	0 Hz
38-F7	Preset Frequency 6	0 to 400 Hz	0 Hz

<b>39-FTL (Minimum Frequency in Torque Limit)</b>	<b>Default = 10 Hz</b>	<b>Level = L2</b>
---	------------------------	-------------------

This parameter sets the lowest frequency that the inverter will decelerate to when in Torque Limit mode. If the load is sufficiently large to drive the inverter below this threshold, the inverter will trip on overcurrent. The deceleration rate is set by 46-DECTL (see page 56 for more information). To disable Torque Limit mode, set 39-FTL to be greater than 32-FMAX.

## Section 7: Parameter Configuration and Description

<b>41-RSEL (Ramp Selector)</b>	<b>Default = 0</b>	<b>Level = L2</b>
--------------------------------	--------------------	-------------------

This parameter selects the acceleration and deceleration ramps that control the motor and whether Ramp-to-Stop or Coast-to-Stop is utilized.

<i>Data Codes</i>	<i>Definition</i>
0	Ramp-to-Stop using the ramps configured by 42-ACC1 and 43-DEC1.
1	42-ACC1 and 43-DEC1 are active in Forward; 44-ACC2 and 45-DEC2 are active in Reverse.
2	When the output frequency is less than preset frequency 37-F6, 42-ACC1 and 43-DEC1 are active; when the output frequency is equal to or greater than parameter 37-F6, 44-ACC2 and 45-DEC2 are active..
3	When 21-MODE is set to 2, 3, or 6, PS3 is re-defined as the Alternate Ramp Time (ART) selector. unless the PI Controller is utilized. When this terminal is active, 44-ACC2 and 45-DEC2 are active. Note that PS3 cannot be used as a preset speed selector when 41-RSEL is set to 3 or when the PI Controller is enabled and PS3 is used as an ON/OFF switch. (See Table 11 on page 20; also see 21-MODE on page 52.)
4	Same as data code 0, except Coast-to-Stop is utilized.
5	Same as data code 1, except Coast-to-Stop is utilized.
6	Same as data code 2, except Coast-to-Stop is utilized.
7	Same as data code 3, except Coast-to-Stop is utilized.

<b>42-ACC1 (Acceleration Time 1)</b>	<b>Default = 3 sec</b>	<b>Level = L1</b>
--------------------------------------	------------------------	-------------------

This parameter sets the length of time to accelerate from 0 Hz to 32-FMAX. The length of time may range from 0.1 to 600 seconds. Note that extremely short acceleration times may result in nuisance fault trips. See 41-RSEL for more information.

<b>43-DEC1 (Deceleration Time 1)</b>	<b>Default = 3 sec</b>	<b>Level = L1</b>
--------------------------------------	------------------------	-------------------

This parameter sets the length of time to decelerate from 32-FMAX to 0 Hz. The length of time may range from 0.1 to 600 seconds. Note that extremely short deceleration times may result in nuisance fault trips or may require external dynamic braking package (see page 88). See 41-RSEL for more information.

<b>44-ACC2 (Acceleration Time 2)</b>	<b>Default = 1 sec</b>	<b>Level = L2</b>
--------------------------------------	------------------------	-------------------

This parameter sets the Alternate Acceleration Ramp and determines the length of time to accelerate from 0 Hz to 32-FMAX. The length of time may range from 0.1 to 600 seconds. Note that extremely short acceleration times may result in nuisance fault trips. See 41-RSEL for more information.

## Section 7: Parameter Configuration and Description

<b>45-DEC2 (Deceleration Time 2)</b>	<b>Default = 1 sec</b>	<b>Level = L2</b>
<p>This parameter sets the Alternate Deceleration Ramp and determines the length of time to decelerate from 32-FMAX to 0 Hz. The length of time may range from 0.1 to 600 seconds. Note that extremely short deceleration times may result in nuisance fault trips or may require external dynamic braking package (see page 88). See 41-RSEL for more information.</p>		
<b>46-DECTL (Deceleration Time in Torque Limit)</b>	<b>Default = 1 sec</b>	<b>Level = L2</b>
<p>This parameter sets the deceleration rate when the inverter is operating in Torque Limit mode. It also serves as the acceleration rate when the inverter is in Torque Limit mode due to a regenerative condition. The length of time may range from 0.1 to 30 seconds. See 39-FTL on page 54 for more information.</p>		

## Section 7: Parameter Configuration and Description

<b>47-DCBRK (DC Brake Time)</b>	<b>Default = 0.2 sec</b>	<b>Level = L2</b>
---------------------------------	--------------------------	-------------------

This parameter selects the time that DC current will be applied to the motor windings. The time may range from 0 to 5 seconds. See 48-DCVLT for the amount of voltage to be applied.

<i>Time Set</i>	<i>Action</i>
0 sec	DC braking is disabled in all modes.
0.05 to 4.95 sec	Timed DC braking with the following conditions: <ul style="list-style-type: none"> <li>In terminal strip Run/Stop, when both FWD and REV terminals are active.</li> <li>In FWD or REV Run mode and the speed reference is reduced to less than 0.1 Hz.</li> <li>A Stop command is given and output frequency decelerates to less than 0.1 Hz.</li> </ul>
5 sec	Continuous DC braking with the following conditions: <ul style="list-style-type: none"> <li>In terminal strip Run/Stop, when both FWD and REV terminals are active.</li> <li>In FWD or REV Run mode and the speed reference is reduced to less than 0.1 Hz.</li> <li>There is no DC braking after a normal deceleration to stop.</li> </ul>

<b>48-DCVLT (DC Brake Voltage)</b>	<b>Default = 2/3 of 52-BOOST</b>	<b>Level = L2</b>
------------------------------------	--------------------------------------	-------------------

This parameter sets the amount of DC voltage to be applied to the motor windings by 47-DCBRK. Programmable from 0 to 15% of the input voltage rating.

### CAUTION

#### **MOTOR OVERHEATING**

Do not use DC Braking as a holding brake or excessive motor heating may result.

**Failure to observe this instruction can result in equipment damage.**

### ATTENTION

#### **SURCHAUFFE DU MOTEUR**

N'utilisez pas le freinage CC comme frein de maintien car cela peut entraîner une surchauffe excessive du moteur.

**Si cette directive n'est pas respectée, cela peut entraîner des dommages matériels.**

## Section 7: Parameter Configuration and Description

<b>5B-MSAT (Motor Saturation Level)</b>	<b>Default setting varies by model</b>	<b>Level = L2</b>
<p>If the inverter is used to control a motor that is significantly smaller than the inverter rating, the motor may draw excessive current in an unloaded condition. This will be evident by a 15-LOAD reading that is high when the motor is unloaded, and reduces when a load is applied. If this occurs, adjust parameter 5B-MSAT in small increments to a lower percentage until parameter 15-LOAD reads 30-45% in an unloaded condition. The parameter may be set from 15% to 85%.</p>		

<b>51-VSEL (V/Hz Characteristic Selector)</b>	<b>Default = 0</b>	<b>Level = L2</b>
---	--------------------	-------------------

This parameter selects one of three V/Hz characteristics (constant torque, pump, or fan curves). Two starting torque boost features may be selected as well.

<i>Data Code</i>	<i>Characteristic Selected (see Figure 14 for graphs)</i>
0	Linear V/Hz, with Auto-Boost, used with constant torque applications. With Auto-Boost, the optimum boost will be selected depending on load and motor conditions. Parameter 52-BOOST sets the maximum boost applied.
1	Linear V/Hz, with constant boost fixed by 52-BOOST.
2	Mixed (linear/quadratic) V/Hz, with Auto-Boost; typical of pumping applications.
3	Mixed V/Hz, with constant boost fixed by 52-BOOST.
4	Quadratic V/Hz, with Auto-Boost, typical of fan applications.
5	Quadratic V/Hz, with constant boost fixed by 52-BOOST.

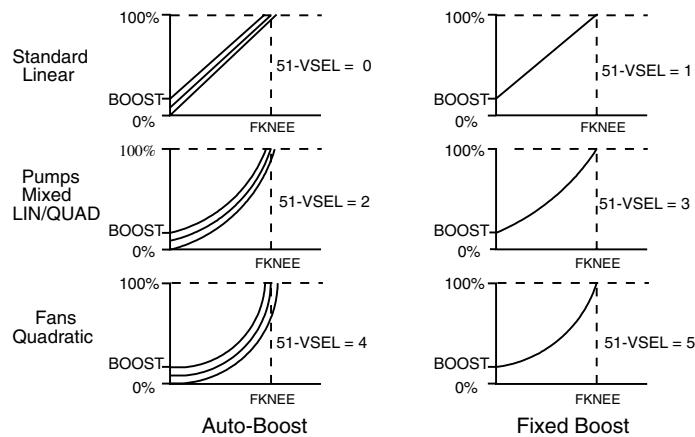

**Figure 14: V/Hz Characteristics**

## Section 7: Parameter Configuration and Description

<b>52-BOOST (Voltage Boost)</b>	<b>Default setting varies by model</b>	<b>Level = L1</b>
---------------------------------	--	-------------------

This parameter increases the motor voltage at low speed to increase the starting torque of the motor, with the voltage boost linearly decreasing with increasing speed. The percentage boost may vary from 0 to 25% of nominal voltage.

### CAUTION

#### **MOTOR OVERHEATING**

Too much boost may cause excessive motor currents and motor overheating. Use only as much boost as is necessary to start the motor. Auto-Boost may be selected at parameter 51-VSEL to provide optimum value of boost to suit the load automatically.

**Failure to observe this instruction can result in equipment damage.**

### ATTENTION

#### **SURCHAUFFE DU MOTEUR**

Une amplification de puissance excessive peut entraîner des surintensités de courant et faire la surchauffe du moteur. N'utilisez que le niveau d'amplification nécessaire pour démarrer le moteur. L'option Auto-Boost peut être sélectionnée au paramètre 51-VSEL pour fournir une valeur d'amplification optimale pour accommoder automatiquement la charge.

**Si cette directive n'est pas respectée, cela peut entraîner des dommages matériels.**

<b>53-FKNEE (V/Hz Knee Frequency)</b>	<b>Default = 60 Hz</b>	<b>Level = L2</b>
---------------------------------------	------------------------	-------------------

This parameter sets the point on the frequency scale at which the output is at full line voltage. Normally, this is set at the base frequency of the motor, but may be increased to enlarge the constant torque range on special motors. Setting FKNEE to a higher value can reduce motor losses at low frequencies. The knee frequency may vary from 26 to 960 Hz.

<b>54-SKBND (Skip Frequency Hysteresis Band)</b>	<b>Default = 1 Hz (2 Hz Band)</b>	<b>Level = L2</b>
--	---------------------------------------	-------------------

Skip bands are used to avoid mechanical resonances in a drive system. This parameter sets the frequency width above and below the frequency to be skipped as configured by 55-SK1, 56-SK2, and 57-SK3. The frequency width may range from 0.2 to 20 Hz in 0.1 Hz increments, which corresponds to band widths of 0.4 to 40 Hz.

## Section 7: Parameter Configuration and Description

<b>55-SK1 (Skip Frequency 1) 56-SK2 (Skip Frequency 2) 57-SK3 (Skip Frequency 3)</b>	<b>Default = 0 Hz</b>	<b>Level = L2</b>
--	-----------------------	-------------------

Each of these parameters sets the center frequency of skip bands over which normal operation will not be allowed. The width of the band is determined by 54-SKBND. The inverter ramps through the frequencies configured by these parameters, but does not settle on them. The value for each of these parameters may range from 0 to 400 Hz in 0.1 Hz increments.

<b>59-MVOLT (Rated Motor Voltage)</b>		<b>Level = L2</b>
---------------------------------------	--	-------------------

This parameter sets the voltage the inverter delivers to the motor terminals at the setting of 53-FKNEE. 230 VAC models are programmable from 185 to 240 volts; 460 VAC models from are programmable from 370 to 480 volts. The inverter attempts to regulate the output voltage with a changing input voltage to better than 5%.

<b>61-LTLF (Load Torque Limit Forward) 62-LTLR (Load Torque Limit Reverse)</b>	<b>Default=150%</b>	<b>Level = L2</b>
--	---------------------	-------------------

These two parameters set the torque limiting points for the inverter in motoring mode, with individual settings for forward and reverse operation. The assigned value may vary from 10 to 150% of the torque load in 1% increments. To disable torque limiting, set parameter 39-FTL to a value greater than 32-FMAX.

<b>63-RTL (Regenerative Torque Limit Forward) 64-RTL (Regenerative Torque Limit Reverse)</b>	<b>Default = 80%</b>	<b>Level = L2</b>
--	----------------------	-------------------

These two parameters set the torque limiting points for the inverter in regenerative mode, with individual settings for forward and reverse operation. The assigned value may vary from 10 to 110% of the torque load in 1% increments. To disable torque limiting, set parameter 39-FTL to a value greater than 32-FMAX.

<b>65-SLIP (Slip Compensation)</b>	<b>Default = 0</b>	<b>Level = L1</b>
------------------------------------	--------------------	-------------------

This parameter allows for compensation of slip in standard NEMA rated induction motors. Do not use this function with synchronous motors as gross instability may occur. This function is automatically disabled when the PI Regulator is enabled.

The assigned value for this parameter may range from 0 to 12%, with a setting of 0% causing slip compensation to be inactive. Use the following formula to calculate slip compensation:

$$65\text{-SLIP} = \text{SLIP} \times \frac{\text{IRAT}}{\text{FLA}} \times 100$$

IRAT = Data Code in 03-IRAT

FLA = Motor Nameplate Current

$$\text{SLIP} = \frac{(\text{Sync. Speed} - \text{Nameplate Speed})}{\text{Sync. Speed}}$$

## Section 7: Parameter Configuration and Description

<b>66-STAB (Current Stability Adjustment)</b>	<b>Default = 3</b>	<b>Level = L2</b>
---	--------------------	-------------------

Lightly loaded motors may oscillate and become unstable due to electromechanical relationships in the motor. This may be more prevalent when the inverter capacity is larger than the motor. This parameter is used to stabilize the motor current in these conditions. The value assigned to this parameter may range from 0 to 4.

<b>67-TOL (Timed Overload Trip Point)</b>	<b>Default = 0%</b>	<b>Level = L1</b>
---	---------------------	-------------------

This parameter defines the load point beyond which a timed electronic trip can occur. Trip time depends on the amount of overload: 1 minute for 150% of the setting, longer for lesser degrees of overload. A 10% overload will not cause the inverter to trip. Parameter 67-TOL is adjustable in 1% increments from 5 to 100% of inverter capacity; a setting of 0% inactivates this feature. Figure 15 on page 62 illustrates the action of 67-TOL. See also parameter 6A-TOLC for setting timed overload appropriately for your motor. The proper setting of parameter 67-TOL is calculated using the value stored at 03-IRAT (see Table 18 on page 51 for the values of 03-IRAT) and the motor nameplate current (Im) as shown in the formula below:

$$67-TOL = \frac{I_m}{IRAT} \times 100\%$$

### ⚠ CAUTION

#### IMPROPER EQUIPMENT COORDINATION

When using multiple motors on a single inverter, use separate external protection on each motor and set 67-TOL to 0 (Disabled).

**Failure to observe this instruction can result in equipment damage.**

### ⚠ ATTENTION

#### MAUVAISE COORDINATION DES APPAREILS

Lorsque vous utilisez plusieurs moteurs sur un seul onduleur, utilisez une protection externe distincte sur chaque moteur et réglez 67-TOL à 0 (invalidé).

**Si cette directive n'est pas respectée, cela peut entraîner des dommages matériels.**

## Section 7: Parameter Configuration and Description

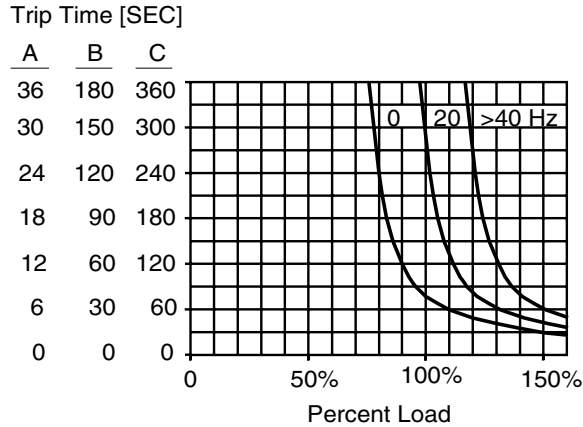

Figure 15: Timed Overload Trip Point

6A-TOLC (Timed Overload Characteristic)		Default = 0	Level = L2	
This parameter works in conjunction with parameter 67-TOL to customize the overload characteristics of the inverter to the driven motor. Refer to Figure 15.				
Data Code	Tripping Characteristic	Trip Time (seconds)	Curve in Figure 15	Motor Type
0	Normal – reduced threshold below 40 Hz	60 <sup>[1]</sup>	C	Standard Induction
1	Medium – reduced threshold below 40 Hz	30 <sup>[1]</sup>	B	Standard Induction
2	Fast – reduced threshold below 40 Hz	6 <sup>[1]</sup>	A	Standard Induction
3	“Shear Pin” – reduced threshold below 40 Hz	0 <sup>[2]</sup>	—	Standard Induction
4	Normal – constant torque	60 <sup>[1]</sup>	C	Inverter Duty
5	Medium – constant torque	30 <sup>[1]</sup>	B	Inverter Duty
6	Fast – constant torque	6 <sup>[1]</sup>	A	Inverter Duty
7	“Shear Pin” – constant torque	0 <sup>[2]</sup>	—	Inverter Duty

1. Trip time is 150% of 67-TOL setting.  
2. Trip time is 110% of 67-TOL setting.

## Section 7: Parameter Configuration and Description

<b>68-NRST (Trip Restart – Number of Attempts)</b>	<b>Default = 0</b>	<b>Level = L2</b>
--	--------------------	-------------------

The inverter automatically attempts to restart after the time delay set by 69-DRST when any fault trip with a code of F11 or greater has occurred. This parameter (68-NRST) determines the number of attempts, and may vary from 1 to 8 times. (When set to 0, this feature is inactive.)

If the FWD or REV terminal is still active (in 2-wire operation), the inverter attempts a restart (see 21-MODE on page 52 and Figure 12 on page 28).

The count will reset if another fault does not occur within 10 minutes. If the configured number of attempts is exceeded within 10 minutes, the inverter will not restart, but will instead display fault trip message F10. **Resetting the fault can result in instant starting.**

<b>69-DRST (Trip Restart – Time Delay)</b>	<b>Default = 0 s</b>	<b>Level = L2</b>
--	----------------------	-------------------

When a fault trip of F11 or greater occurs, and if 68-NRST is greater than zero, the inverter will wait for the number of seconds set by this parameter (69-DRST) before attempting a restart. The time delay may vary from 0 to 60 seconds in 1 second increments. The type of restart is controlled by the setting of 82-START.

### **WARNING**

#### **UNINTENDED EQUIPMENT ACTION**

Ensure that automatic restarting will not cause injury to personnel or damage to equipment.

**Failure to observe this instruction can result in serious injury or equipment damage.**

### **AVERTISSEMENT**

#### **ACTIONNEMENT INVOLONTAIRE DE L'APPAREIL**

Assurez-vous qu'un redémarrage automatique n'entraînera ni des blessures au personnel ni des dommages matériels.

**Si cette directive n'est pas respectée, cela peut entraîner des blessures graves ou des dommages matériels.**

<b>70-MCAL (Analog Meter Output [MET1] Calibration)</b>	<b>Default = 10 VDC</b>	<b>Level = L1</b>
---	-------------------------	-------------------

This parameter adjusts the meter output value at terminal MET1, and may be programmed while the inverter is running. The value may range from 0 to 255. See 71-METER for MET1 selection.

## Section 7: Parameter Configuration and Description

<b>71-METER (Analog Meter Output [MET1] Selector)</b>	<b>Default = 1</b>	<b>Level = L1</b>
This parameter selects the analog output signal to be indicated at terminal MET1. The factory full scale setting is 10 VDC, but can be changed using parameter 70-MCAL.		
<i>Data Code</i>	<i>Description</i>	
0	Output off.	
1	Output proportional to output frequency (12-FOUT), with full scale at 32-FMAX.	
2	Output proportional to output current (14-IOUT), with full scale at 200% of rated current.	
3	Output proportional to inverter load (15-LOAD), with full scale at 200% of rated load.	
4	Output proportional to output voltage (13-VOUT), with full scale at 100% of input voltage.	

## Section 7: Parameter Configuration and Description

<b>72-ST1 (Digital Output ST1) 75-STR (Digital Output RCM)</b>	<b>Default = 7 Default = 2</b>	<b>Level = L1</b>
--	------------------------------------	-------------------

The ST1 and RCM digital outputs may be configured to respond to any of the conditions listed below. Also see the section on Control Terminals on page 19.

<i>Data Code</i>	<i>Description</i>
0	Output off.
1	The output becomes active when the inverter is ready. It is inactive in Fault, Low Voltage, and Program modes.
2	The output becomes active on Fault <sup>[1]</sup> .
3	The output becomes active when the motor is running in Forward or Reverse and output frequency is above 0.5 Hz.
4	The output becomes active when the motor is running in Reverse and output frequency is above 0.5 Hz.
5	The output becomes active when the motor is running in Forward and output frequency is above 0.5 Hz.
6	The output becomes active when output frequency is above 0.5 Hz.
7	The output becomes active when the motor is running at commanded speed.
8	The output becomes active when the motor speed is greater than preset frequency 36-F5.
9	The output becomes active in Torque Limit mode.
10	Overtemperature warning – the output becomes active when the temperature is within 10 °C of maximum temperature.

1. Note that when automatic fault reset and restart are utilized (68-NRST), a fault greater than F10 will not be indicated until the time delay set by 69-NRST expires.

## Section 7: Parameter Configuration and Description

<b>77-MOL (Motor Overload Input)</b>	<b>Default = 0</b>	<b>Level = L2</b>
--------------------------------------	--------------------	-------------------

This parameter sets the motor overload input function and polarity. This parameter in conjunction with the J20 jumper defines the function of the MOL input terminal. It can be defined to generate an F07 fault or a Coast-to-Stop condition using either normally-open or normally-closed contacts. J20 sets the input terminals for pull-up or pull-down logic (see page 21 for more information).

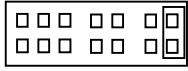
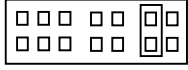
<i>J20 Setting</i>	<i>Data Code</i>	<i>Description (MOL Connection)</i>
	0	High input (V+) or external signal (max +24 VDC referenced to CM) will generate an F07 Fault (N.O. operation).
	1	Removal of high input (V+) or external signal will generate an F07 Fault (N.C. operation).
	2	High input (V+) or external signal (max +24 VDC referenced to CM) will generate a Coast-to-Stop (N.O. operation).
	3	Removal of high input (V+) or external signal will generate a Coast-to-Stop (N.C. operation).
	0	Connecting MOL to CM will generate an F07 Fault (N.O. operation).
	1	Opening MOL-CM connection will generate an F07 Fault (N.C. operation).
	2	Connecting MOL to CM will generate a Coast-to-Stop (N.O. operation).
	3	Opening MOL-CM connection will generate a Coast-to-Stop (N.C. operation).

Note: External thermal overload relay rating = 1.1 x motor continuous nameplate Amps.

<b>78-MCAL2 (Analog Meter Output [MET2] Calibration)</b>	<b>Default = 20 mA</b>	<b>Level = L1</b>
--	------------------------	-------------------

This parameter adjusts the output value at terminal MET2, and may be programmed while the inverter is running. The value may range to 0 to 255. See 79-MET2 for MET2 selection.

## Section 7: Parameter Configuration and Description

<b>79-MET2 (Analog Meter Output [MET2] Selector)</b>	<b>Default = 3</b>	<b>Level = L1</b>
--	--------------------	-------------------

This parameter selects the analog output signal to be indicated at terminal MET2. The factory full scale setting is 20 mA, but can be changed using parameter 78-MCAL2.

<i>Data Code</i>	<i>Output Range</i>	<i>Description</i>
0	—	Output off.
1	0 to 20 mA DC	Output proportional to output frequency (12-FOUT), with full scale at 32-FMAX.
2	0 to 20 mA DC	Output proportional to output current (14-IOUT), with full scale at 200% of rated current.
3	0 to 20 mA DC	Output proportional to inverter load (15-LOAD), with full scale at 200% of rated load.
4	—	Output proportional to output voltage; full scale = input line voltage. Meter calibration must be set to 189 for this option.
11	4 to 20 mA DC	Output proportional to output frequency (12-FOUT), with full scale at 32-FMAX.
12	4 to 20 mA DC	Output proportional to output current (14-IOUT), with full scale at 200% of rated current.
13	4 to 20 mA DC	Output proportional to inverter load (15-LOAD), with full scale at 200% of rated load.
14	—	Output proportional to output voltage; full scale = input line voltage.

<b>81-PRGNO (Special Program)</b>	<b>Default = 0</b>	<b>Level = L2</b>
-----------------------------------	--------------------	-------------------

This parameter allows for storing and resetting parameters and activating special functions. The function will be executed upon exiting the Program mode.

<i>Data Code</i>	<i>Description</i>
0	Standard program.
1	Reset parameters to factory settings (display = SETP).
2	Store customer parameter settings (display = STOC).
3	Recall customer parameter settings (display = SETC).
80 – 95	Enables the PI Controller; see Chapter 8 on page 73 for further information.
101	Enables VIN1 Span Adjustment - C0-VINSPAN

## Section 7: Parameter Configuration and Description

82-START (Start Options)	Default = 0	Level = L2
<p>This parameter controls the operation of Line Start Lock-Out and/or Auto-Start into a rotating motor. Also, it enables or disables the STOP key as an emergency stop when operating from the terminal strip, and enables or disables the Stop function due to disconnection of a remote device connected through J22. See page 83 for special display indications used with this parameter.</p>		
<i>Data Code</i>	<i>Description</i>	
0	Line Start Lock-out. If maintained contact run operators are used, they must be opened and then re-closed for the inverter to start after application of AC power. STOP key active as emergency, Coast-To-Stop, when parameter 21-MODE is set to 2 through 9. To reset an emergency stop, press the STOP key again. No Stop with signal loss at connector J22.	
1	Auto-Start. Will start on power-up if direction connection is made at the control terminals after application of AC power. STOP key active as emergency, Coast-to-Stop, when parameter 21-MODE is set to 2 through 9. To reset an emergency stop, press the STOP key again. No Stop with signal loss at connector J22.	
2	Start into a rotating motor with Line Start Lock-out. STOP key active as emergency, Coast-to-Stop, when parameter 21-MODE is set to 2 through 9. To reset an emergency stop, press the STOP key again. No Stop with signal loss at connector J22.	
3	Start into a rotating motor with Auto-Start. STOP key active as emergency, Coast-to-Stop, when parameter 21-MODE is set to 2 through 9. To reset an emergency stop, press the STOP key again. No Stop with signal loss at connector J22.	
4 – 7	Same Start functions as data codes 1-3, but Keypad STOP key will be disabled if Start/Stop is defined as terminals by parameter 21-MODE. No Stop with signal loss at connector J22.	
8 – 11	Same Start functions as data codes 1-3, but inverter will initiate a Stop function (as defined by 41-RSEL) if a remote device signal is sensed at connector J22 and then lost.	

### **WARNING**

#### **UNINTENDED EQUIPMENT OPERATION**

Starting into a rotating motor, a lightly loaded motor may suddenly accelerate before locking in the proper speed. Ensure that this operation will not cause injury to personnel or damage to equipment.

**Failure to observe this instruction can result in serious injury or equipment damage.**

**⚠ AVERTISSEMENT**

**FONCTIONNEMENT INVOLONTAIRE DE L'APPAREIL**

Si, lors du démarrage, un moteur tourne sous charge légère, il peut accélérer soudainement avant d'atteindre la vitesse appropriée. Assurez-vous que cette opération n'entraînera ni des blessures au personnel ni des dommages matériels.

**Si cette directive n'est pas respectée, cela peut entraîner des blessures graves ou des dommages matériels.**

<b>83-PWM (PWM Carrier Frequency)</b>	<b>Default = 1</b>	<b>Level = L2</b>
---------------------------------------	--------------------	-------------------

This parameter sets the carrier frequency of the Pulse Width Modulation (PWM) waveform supplied to the motor. Low carrier frequencies provide better low end torque, but produce some audible noise from the motor. Higher carrier frequencies produce less audible noise, but cause more heating in the inverter and motor. The X2C inverter is rated to produce continuous full load current at rated temperatures (see Table 1 on page 4, Table 6 on page 9, and Table 7 on page 9) when 83-PWM is set to the factory setting (Data Code 1, 4 kHz). Data Code 0 (Autoselect) automatically selects the highest carrier frequency permitted without overheating the inverter. See Table 20 on page 70 for maximum allowable loading by inverter model when used with the available carrier frequencies..

<i>Data Code</i>	<i>Carrier Frequency</i>	<i>Data Code</i>	<i>Carrier Frequency</i>
0	Autoselect	3	8 kHz
1	4 kHz	4	12 kHz
2	6 kHz	5	16 kHz

Note: 12 and 16 kHz levels automatically shift to 6 and 8 kHz respectively, and then to 4 kHz, if derating is exceeded. In Autoselect, the inverter runs at 16 kHz then automatically shifts to 8 kHz in the event of low output voltage, if the derating is exceeded, or if inverter temperature exceeds 70 °C. If inverter temperature further exceeds 85 °C, the inverter shifts to 4 kHz. Upshifting occurs if the temperatures drop below these thresholds.

**Section 7: Parameter Configuration and Description**

**Table 20: High Carrier Frequency Derating**

<b>Model</b>	<b>Continuous Load Rating @ 4 kHz</b>	<b>Continuous Load Rating @ 6 &amp; 8 kHz</b>	<b>Continuous Load Rating@ 12 &amp; 16 kHz</b>
X2C1000-5	110%	110%	110%
X2C1001-0	110%	108%	89%
X2C2000-5	110%	110%	110%
X2C2001-0	110%	108%	89%
X2C2002-0	110%	79%	62%
X2C2003-0	110%	92%	67%
X2C2005-0	110%	91%	66%
X2C2007-5	110%	110%	110%
X2C2010-0	110%	110%	80%
X2C2015-0	110%	110%	80%
X2C2020-0	110%	110%	80%
X2C4001-0	110%	105%	45%
X2C4002-0	110%	76%	57%
X2C4003-0	110%	110%	73%
X2C4005-0	110%	73%	44%
X2C4007-5	110%	110%	110%
X2C4010-0	110%	110%	110%
X2C4015-0	110%	110%	110%
X2C4020-0	110%	110%	70%

## Section 7: Parameter Configuration and Description

<b>84-DISP (Display Option Setting)</b>	<b>Default = 0</b>	<b>Level = L2</b>
---	--------------------	-------------------

This parameter defines the information to be displayed on the LCD readout during Run operation. (The display always shows frequency when the inverter is stopped and while speed is being set.)

<i>Data Code</i>	<i>Description</i>
0	Output frequency in Hz (value of 12-FOUT).
1	Output current in amps (value of 14-IOUT).
2	Inverter load in percent (value of 15-LOAD).
3	FSTAT (stator frequency); see 71-METER for definition.
4 – 3000	The display indicates rpm. Number displayed x 20/12-FOUT = Data Code. Example: To display 1800 rpm at 60 Hz, 1800 x 20/60 = 600. (Note: Data code must be rounded to nearest whole number.)

<b>87-ACODE (Security Access Code)</b>	<b>Default = 0</b>	<b>Level = L2</b>
--	--------------------	-------------------

Entering a number between 1 and 999 provides controlled access to parameters (both Level 1 and Level 2). After an access code has been entered, the initial display will be as illustrated in Figure 16. After the proper security code is entered, the display will return to the normal Program mode display. You now have 10 minutes of unhindered access unless power is removed and reapplied.



**Figure 16: Security Access Display**

<b>97-RVLVL2 (Software Revision Level 2)</b>		<b>Level = L2</b>
--	--	-------------------

This parameter displays the secondary software revision level.

## Section 7: Parameter Configuration and Description

<b>C0-VINSPAN (Span Adjustment for VIN1)</b>	<b>8950</b>	<b>Level = L2</b>
--	-------------	-------------------

This parameter must be enabled by setting 81-PRGNO to 101. This parameter allows the actual frequency output of the X2C to be calibrated to analog input reference signal (VIN1). For example, if a greater frequency output is desired for a given VIN1 signal level, parameter C0 should be increased. Likewise, if a lesser frequency output is desired for a given VIN1 signal level, parameter C0 should be decreased.

<b>C1-MET2OFST (Offset Adjustment for MET2)</b>	<b>180</b>	<b>Level = L2</b>
---	------------	-------------------

This parameter enables the MET2 analog output to be adjusted when running in a 4-20ma mode (see 79-MET2 for information on configuring MET2 for a 4-20ma mode). After configuring MET2 for 4-20ma mode, parameter C1-MET2OFST may be used to adjust the actual current level of the MET2 analog output at the 0% (4ma) point. To increase the actual current level of the MET2 output at the 0% (4ma) point, increase parameter C1-MET2OSFT. To decrease the actual current level of the MET2 output at the 0% (4ma) point, decrease parameter C1-MET2OFST.

---

## Section 8: PI Controller

### 8.1 Introduction

E-trAC X2C inverters have a built-in PI (Proportional-Integral) Controller that makes it possible to control a process by adjusting motor speed using a reference input and a feedback input. When PI control is enabled, several new parameters (as well as new data codes for some existing parameters) become available to support PI control.

This section first provides an overview of how PI control operates. Following this discussion, the new parameters and data codes are described.

### 8.2 Overview of PI Control

Figure 17 on the next page provides a flowchart of PI control. The characteristics of PI control are set with the 81-PRGNO parameter (see page 81). The data codes for parameter 81-PRGNO allow you to select:

- Direct- or reverse-acting loop  
In a direct-acting loop, a positive error will cause an increase in output frequency. Conversely, in a reverse-acting loop, a positive error will cause a decrease in output frequency.
- Slow or fast rate of integration  
A slow rate of integration is usually selected for processes with long time constraints (for example, thermal and fluid level controls). On the other hand, a fast integration rate is utilized for processes with short time constraints (such as mechanical systems and pressure loops).
- Whether feed-forward is active  
Feed-forward is useful in situations where the reference value has a direct relation to the feedback signal, such as controlling motor speed in a closed loop. Note that feed-forward should be enabled when attempting to close a speed loop.
- Whether the PI Controller is turned on and off via the PS3 input

Separate parameters are also available for adjusting proportional gain (parameter B3-KP), integral gain (parameter B4-KI), and scaling for the feedback terminal VIN2 (parameter B5-KIN). These parameters may be adjusted while the inverter is operating.

Section 8: PI Controller

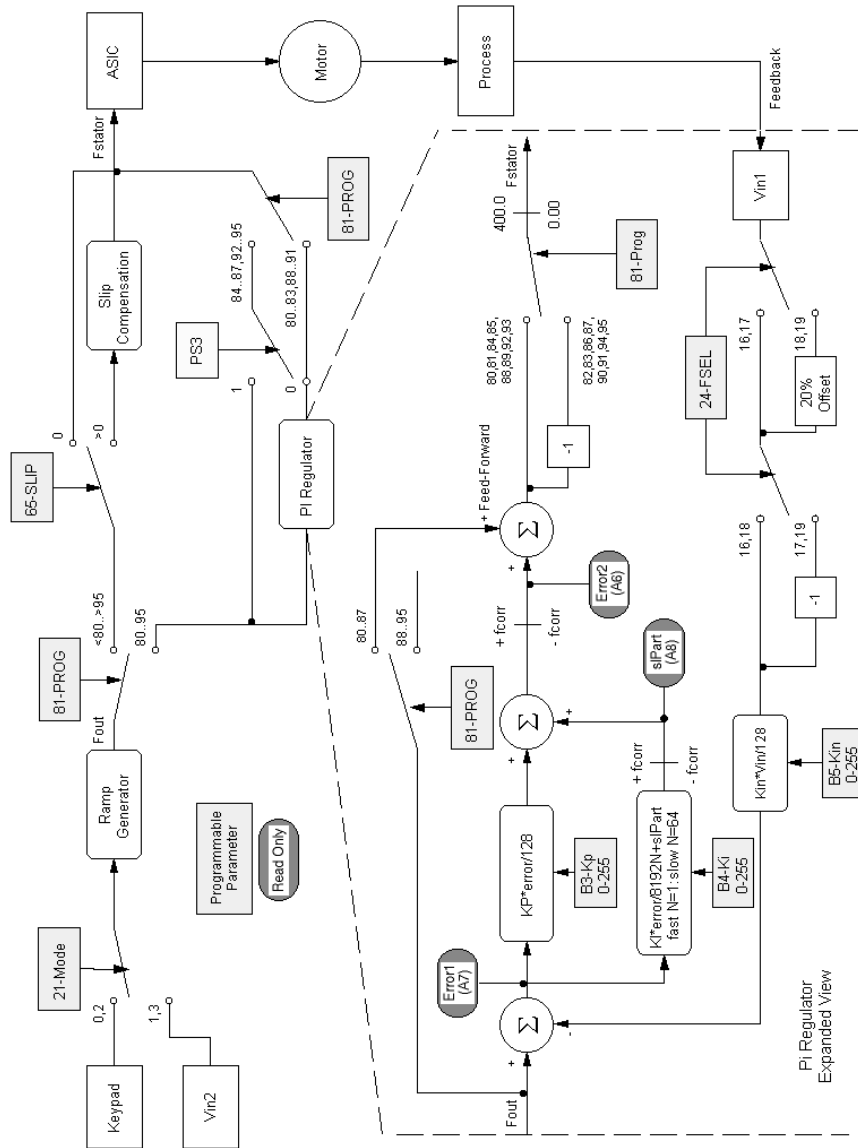

Figure 17: PI Controller Functional Diagram

The PI Controller operates within the limits set by parameter A1-FCORR, the value of which establishes the frequency band across which the value of the integrator and the output of the PI Controller may vary. If Feed-Forward is active, the output of the PI Controller is the reference frequency  $12\text{-FOUT} \pm A1\text{-FCORR}$ , and the integrator's value is  $\pm A1\text{-FCORR}$ . Note that the final output of the PI Controller cannot be less than 0.00 Hz nor greater than 400.00 Hz.

The output of the PI Controller is sent to the ASIC after the proper frequency conversion. The controller works in one direction of rotation which must be set by FWD and REV commands. A change in direction while the controller is active yields unpredictable results.

The PI controller is limited in its application by the minimum resolution available through the feedback terminal. Since the feedback terminal voltage is scaled through an 8-bit analog-to-digital converter, the reaction of the PI loop is reduced.

For example, if the inverter is set to run from 0.00 to 60.00 Hz and the feedback is coming from a tachometer rated at 50 V/1000 rpm and conditioned to be between 0-10 V with 2000 RPM being full scale, then the minimum change that the 8-bit A/D converter can register is 8 rpm. This means that, worst case, the speed can drop by 8 rpm when a load is applied, but typical accuracy is  $\pm 2$  rpm.

Input CTS or a STOP command (or inputs FWD and REV active at the same time) stops the inverter and resets the integrator part (sIPart) of the PI Controller when the value of 12-FOUT falls below 0.10 Hz.

### 8.3 Reference and Feedback Inputs

#### A. Configuration of Inputs

The PI reference value is input from either the keypad or the VIN2 terminal. The PI feedback value is input from the VIN1 terminal. An error signal is calculated by the microprocessor which adjusts the speed of the inverter within a range limited by the A1-FCORR parameter.

The PI feedback input (VIN1) is selectable through J20 as 0 to 5 VDC, 0-10 VDC, 0 to 20 mA, or 4 to 20 mA. The PI reference input (VIN2) is selectable through J20 as 0 to 5 VDC or 0 to 10 VDC.

Parameter 24-FSEL is used to set the feedback input to be direct, inverted, or a 20% offset from the minimum. This parameter must also

## Section 8: PI Controller

be set to 16, 17, 18, or 19 to use VIN2 as the reference input. *Enabling the PI Controller without properly setting 24-FSEL could result in the use of a combination of VIN1 and VIN2 as the reference signal, which will give unpredictable results.*

### B. Scaling the Feedback Input

The feedback input (VIN1) is scaled between 0.00 Hz and 1.125 times FMAX. For example, if VIN1 is set to direct and FMAX is 60.00 Hz, then a full scale feedback signal will correspond to 67.50 Hz.

This feedback input can also be scaled, via B5-KIN, from 0 to 255 which corresponds to a range of 0 to 1.99. For example, if B5-KIN=64, then a full scale feedback signal would correspond to 33.75 Hz.

The function of scaling is to compensate the input for conditioning difficulties of the feedback signal. For instance, if the feedback is from an analog tachometer that gives a 50 V/1000 rpm signal and the inverter is set up to have an FMAX of 60.0 Hz (which means that VIN1 needs to read a signal of 67.5 Hz), then the maximum voltage from the tachometer will be 101.25 V.

This means that a voltage divider scaled to 0.0987 must be used if a maximum input voltage of 10 V is desired. Since voltage dividers are rarely exact, parameter B5-KIN can be used to compensate. In this case, the divider gain was actually 0.100. This means that the input will be off scale by a factor of 1.01 which can be compensated by scaling to 0.987 or B5-KIN set to 126. See page 77 for an equation for calculating B5-KIN.

*NOTE: Setting B5-KIN less than 128 or a scale less than 1 will limit the maximum speed that the feedback terminal can read and therefore could cause unpredictable results. See page 77 for an equation for calculating the maximum feedback terminal.*

## 8.4 Calculating PI Controller Values

The integral part of the PI controller output is calculated as follows:

$$sIPart = sIPart + \left[ \frac{kl \times e}{8192 \times N} \right]$$

N=1 for fast integrator, 64 for slow integrator

e=Fout-Feedback (error signal calculated by PI Controller)

kP, kl, kIN=0 to 255

Actual output speed of PI controller is calculated as follows:

$$\text{ActualOutputSpeed} = \text{sIPart} + \left[ \frac{\text{kP} \times e}{128} \right]$$

To calculate maximum feedback:

$$\text{Maximum Feedback:} = \left[ \frac{\text{kIN}}{128} \right] \times \left[ \frac{9 \times \text{FMAX}}{8} \right]$$

To calculate actual feedback:

$$\text{Actual Feedback:} = \text{Fin} \times \left[ \frac{\text{kIN}}{128} \right] \times \left[ \frac{9 \times \text{FMAX}}{8} \right]$$

:FIN is % of full scale voltage or current

To calculate B5-KIN (calculated voltage scaling ratio of feedback signal):

$$A_{\text{DIV}} = \frac{V_{\text{MAX}}}{[33.75 \times \text{FMAX} \times P_V]}$$

$$K_{\text{IN}} = 128 \times \frac{A_{\text{DIV}}}{V_{\text{DIVA}}}$$

$P_V$  = Process Parameter in Volts/RPM

$V_{\text{MAX}}$  = Maximum Input Voltage (5 V or 10 V)

$A_{\text{DIVA}}$  = ActualVoltage Divider Ratio

## Section 8: PI Controller

### 8.5 Parameters for PI Control

#### A. Additional Parameters for PI Control

The following parameters become available when PI control is enabled; they are not available when PI control is not utilized.

Parameter		Range or Units	Level	Description
<b>1A-FSTAT</b>	Stator Frequency	—	L2	Shows the stator frequency; the value may only be read; it cannot be altered
<b>A1-FCORR</b>	Frequency Correction	0.0 to 400.0 Hz	L2	Used to limit the variation of the PI Regulator around the value of parameter 12-FOUT.
<b>A6-ERROR2</b>	Final Error	—	L2	This parameter is the Final Error of the PI Regulator. It is calculated from PI output minus the value of 12-FOUT. The value may only be read.
<b>A7-ERROR1</b>	Initial Error	—	L2	This parameter is the Initial Error of the PI Regulator. It is calculated from 12-FOUT minus feedback. The value may only be read.
<b>A8-SIPART</b>	Integral Sum	—	L2	This parameter is the sum of the integral term of the PI Regulator. The value may only be read.
<b>B3-KP</b>	Proportional Gain	0 to 255	L2	This parameter sets the proportional gain.
<b>B4-KI</b>	Integral Gain	0 to 255	L2	This parameter sets the integral gain.
<b>B5-KIN</b>	VIN2 Scaling	0 to 255	L2	This parameter sets the scaling for feedback terminal VIN2.

**B. Parameters Re-Defined for PI Control**

This section describes amendments to existing parameters when the PI Controller is utilized.

<b>21-MODE (Input Mode)</b>		<b>Default = 0</b>	<b>Level = L1</b>
This parameter defines the source for speed reference and Run/Stop control input. The values shown below replace those given on page 52.			
<i>Data Codes</i>	<i>Speed Control Source</i>	<i>Run/Stop Control</i>	
0	Keypad	Keypad (Forward only)	
1	VIN2 Terminals	Keypad (Forward only)	
2	Keypad	Terminals (2-wire maintained contact)	
3	VIN2 Terminals	Terminals (2-wire maintained contact)	

<b>24-FSEL (Speed Setpoint Selector)</b>		<b>Default = 0</b>	<b>Level = L2</b>
This parameter defines the speed setpoint selector. The values shown below are in addition to those given on page 53.			
<i>Data Codes</i>	<i>Description<sup>[1]</sup></i>		
16	Both VIN1 and VIN2 are direct.		
17	VIN1 is inverted and VIN2 is direct.		
18	VIN1 is direct with a 20% offset and VIN2 is direct.		
19	VIN1 is inverted with a 20% offset and VIN2 is direct.		

1. Direct is defined as maximum output (32-FMAX) at maximum input; inverted is defined as minimum output (31-FMIN) at maximum input.

<b>41-RSEL (Ramp Selector)</b>		<b>Default = 0</b>	<b>Level = L2</b>
This parameter selects the acceleration and deceleration ramps that control the motor and whether Ramp-to-Stop or Coast-to-Stop is utilized. When PS3 is used as an ON/OFF switch for the PI Regulator, it cannot be used for the Alternate Ramp Time (ART) configured by data codes 3 and 7. See page 55 for the other data codes that may be assigned to parameter 41-RSEL.			
<i>Data Codes</i>	<i>Definition</i>		
3	Not available.		
7	Not available.		

## Section 8: PI Controller

<b>65-SLIP (Slip Compensation)</b>	<b>Default = 0</b>	<b>Level = L1</b>
------------------------------------	--------------------	-------------------

When the PI Regulator is enabled, slip compensation is automatically disabled. See page 60 for further information about this parameter.

<b>71-METER (Analog Meter Output [MET1] Selector)</b>	<b>Default = 1</b>	<b>Level = L1</b>
---	--------------------	-------------------

This parameter selects the analog output signal to be indicated at terminal MET1. The factory full scale setting is 10 VDC, but can be changed using parameter 70-MCAL. In addition to the values shown on page 64, the following data codes are added when the PI Regulator is enabled.

<i>Data Code</i>	<i>Description</i>
5	The output is proportional to actual stator frequency (1A-FSTATOR), with full scale at 32-FMAX.

<b>79-MET2 (Analog Meter Output [MET2] Selector)</b>	<b>Default = 1</b>	<b>Level = L1</b>
--	--------------------	-------------------

This parameter selects the analog output signal to be indicated at terminal MET2. The factory full scale setting is 20 mA, but can be changed using parameter 78-MCAL2.

<i>Data Code</i>	<i>Output Range</i>	<i>Description</i>
5	0 to 20 mA DC	The output is proportional to actual stator frequency (1A-FSTATOR), with full scale at 32-FMAX.
15	4 to 20 mA DC	The output is proportional to actual stator frequency (1A-FSTATOR), with full scale at 32-FMAX.

## Section 8: PI Controller

<b>81-PRGNO (PI Control Characteristics)</b>		<b>Level = L1</b>
--	--	-------------------

This parameter selects the characteristics of the PI Controller. By selecting the appropriate data code, you may select direct- or reverse-acting loop, slow or fast rate of integration, whether feed-forward is active, and whether on/off control is via PS3 (see page 73 for more information). The values shown here replace those given on page 67.

<i>Data Code</i>	<i>Type of Loop</i>	<i>Integration Rate</i>	<i>Feed-Forward</i>	<i>PI Enabled by PS3?</i>
80	Direct	Slow	Active	No
81	Direct	Fast	Active	No
82	Reverse	Slow	Active	No
83	Reverse	Fast	Active	No
84	Direct	Slow	Active	Yes
85	Direct	Fast	Active	Yes
86	Reverse	Slow	Active	Yes
87	Reverse	Fast	Active	Yes
88	Direct	Slow	Inactive	No
89	Direct	Fast	Inactive	No
90	Reverse	Slow	Inactive	No
91	Reverse	Fast	Inactive	No
92	Direct	Slow	Inactive	Yes
93	Direct	Fast	Inactive	Yes
94	Reverse	Slow	Inactive	Yes
95	Reverse	Fast	Inactive	Yes

**NOTES**

---

## Section 9: Troubleshooting

### **⚠ WARNING**

#### **HAZARDOUS VOLTAGE**

Before servicing the electrical system:

- Disconnect all power.
- Wait one minute until DC bus capacitors discharge.

**Failure to observe this instruction can result in death or serious injury.**

### **⚠ AVERTISSEMENT**

#### **TENSION DANGEREUSE**

Avant l'entretien du système électrique :

- Coupez toute source d'alimentation.
- Attendez une minute que la décharge des condensateurs du bus CC s'effectue.

**Si cette directive n'est pas respectée, cela peut entraîner la mort ou des blessures graves.**

### 9.1 Special Indications

In addition to the standard operation and programming displays, several special displays may appear:

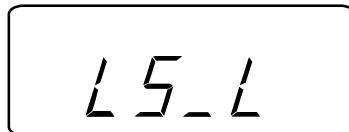

Line Start Lockout.  
See 82-START on page 68.

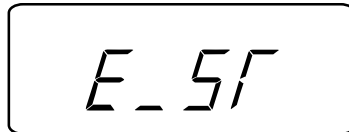

Emergency Stop.  
See 82-START on page 68.

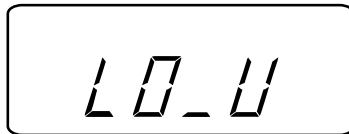

Low Voltage.  
AC line voltage too low.

**Figure 18: Special Displays**

## Section 9: Troubleshooting

### 9.2 Fault Trip Indications

In the event of a fault trip, the STATUS indicator blinks red and the display shows the fault code as illustrated in Figure 19. See page 85 for fault codes.

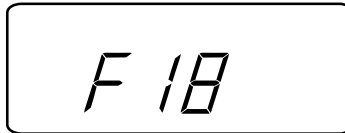

**Figure 19: Fault Code Indicator**

Pressing the UP arrow before the fault is reset displays the status of the inverter at the time of the fault as shown in Figure 20. Note that more than one annunciator may be displayed to better define the cause of the fault. Additional information concerning the inverter status at the time of the fault is available by pressing the PRG key and viewing parameters 12 through 17.

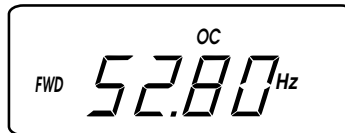

**Figure 20: Status at Time of Fault**

### 9.3 Resetting a Fault

Faults can be reset in any one of four ways:

1. Pressing the STOP key on the keypad.
2. Activating and then deactivating both the FWD and REV terminals simultaneously.
3. Removing and restoring AC power.
4. Using the automatic restart function 68-NRST; see page 63.

## 9.4 Fault Codes

Fault	Cause	Remedy
F01	Computer Malfunction	<ol style="list-style-type: none"> <li>1. Reset the inverter using the stop key for longer than 1 second.</li> <li>2. If the problem persists, consult the factory.</li> </ol>
F02	Parameter Block Fault	<ol style="list-style-type: none"> <li>1. Restore all parameters to factory settings by setting 81-PROG to 1.</li> <li>2. If the problem persists, consult the factory.</li> </ol>
F03	Bus Current Measurement Fault	<ol style="list-style-type: none"> <li>1. Reset the fault by pressing the stop key.</li> <li>2. If the problem persists, consult the factory.</li> </ol>
F04	Power Supply Overload	Check for excessive loading on control terminals REF and V+. (See Table 10 on page 19.)
F05	No DC Bus Voltage	<ol style="list-style-type: none"> <li>1. Check for proper source voltage.</li> <li>2. Check for DB component or output transistor failure.</li> <li>3. Check for shorted DC bus.</li> </ol>
F06	Output Short Circuit	<ol style="list-style-type: none"> <li>1. Check motor wiring.</li> <li>2. Reduce 52-BOOST.</li> <li>3. Extend 42-ACC1 accel ramp.</li> </ol>
F07	External Fault Mechanism (Motor Overload Relay) Tripped	<ol style="list-style-type: none"> <li>1. Check motor temperature.</li> <li>2. Verify the sizing of MOL.</li> </ol>
F09	Loss of Communication with Control Terminal Strip	<ol style="list-style-type: none"> <li>1. Reset the inverter using the stop key for longer than 1 second.</li> <li>2. If the problem persists, consult the factory.</li> </ol>
F10	Auto-Restart (68-NRST) Number Exceeded	<ol style="list-style-type: none"> <li>1. Check the fault log (parameters 07-FLT3, 08-FLT2, and 09-FLT1).</li> <li>2. Initiate corrective action for those faults.</li> </ol> <p>NOTE: Resetting this fault may cause instant starting. Ensure that doing so will not cause harm to personnel or damage to equipment.</p>
F11	Ground Fault	<ol style="list-style-type: none"> <li>1. Check motor wiring.</li> <li>2. Check for and remove any capacitive load.</li> </ol>
F13	Overvoltage on DC Bus	<ol style="list-style-type: none"> <li>1. Verify line voltage.</li> <li>2. Check for excessive regenerative load.</li> <li>3. Increase deceleration time.</li> <li>4. Reduce preset regenerative current limit value.</li> </ol>
F15	DB Overload	<ol style="list-style-type: none"> <li>1. Reduce braking duty cycle.</li> <li>2. Install optional external DB package.</li> <li>3. Verify line voltage.</li> </ol>
F16	Acceleration Overcurrent	<ol style="list-style-type: none"> <li>1. Increase acceleration ramp time.</li> <li>2. Check motor wiring for short circuit.</li> <li>3. Check for normal operation with motor disconnected.</li> </ol>

## Section 9: Troubleshooting

Fault	Cause	Remedy
F17	Deceleration Overcurrent	1. Increase deceleration ramp time. 2. Reduce preset regenerative current limit value.
F18	Running Overcurrent	Locate cause of mechanical overload on the motor.
F19	Heat Sink Over Temperature	1. Check for excessive overload. 2. Verify the proper sizing of the inverter for the application. 3. Locate the inverter in a cooler location, out of direct sunlight.
F20	Timed Overload	1. Check programming of 67-TOL. 2. Check for overload on the motor.

Notes:

1. F01 through F11 are checked during the power-up sequence.
2. F02 is also checked during programming.
3. Faults F11 through F20 will be reset if the Auto-Restart function is selected (see 68-NRST).

### 9.5 Troubleshooting Procedures

Problem	Check Point	Corrective Action
Motor is not running	Incorrect wiring	Check all power and control wiring.
	External frequency command (if used)	1. Verify that the external frequency control signal is properly connected. 2. Verify the integrity of the frequency control potentiometer.
	Programming selections	Verify that the proper programming selections were made for the application.
	Fault	1. Verify that the inverter has not shut down due to a fault condition. 2. Refer to page 85 for fault codes.
	Motor stall	1. Release any overload on the motor. 2. Verify that adequate torque boost is available.
Motor speed fluctuation	Loose terminal connection	1. Stop the inverter, turn off power, and tighten all terminal screws. 2. Check for tightness of all connections within the inverter.
	Frequency control potentiometer erratic	Replace frequency control potentiometer.
Motor speed too high or too low	Frequency profile	Verify that the setting of 31-FMIN, 32-FMAX, & 53-FKNEE are correct for the motor specification and application.
	Frequency control signal	Verify the input signal level.
	Motor nameplate specifications	Verify that the motor selection is proper for the application.

---

## Section 10: Options and Replacement Parts

### 10.1 Hassle-Free Warranty

The driving force at TB Wood's is customer service, including dealing with unforeseen problems without creating new ones! TB Wood's takes the extra step to ensure that ANY problem that occurs to its electronic products is dealt with swiftly and with no hassles to you. The Hassle-Free Warranty removes the "burden of guilt" and promises to quickly replace any failed product.

TB Wood's Incorporated warrants its electronic controls to be free of defects in parts or workmanship for a period of two years from the date of manufacture. If a TB Wood's product fails for any reason, excluding physical abuse or repeated failure, within the warranty period, TB Wood's will promptly replace the product. TB Wood's Incorporated shall not in any event be liable for any incidental or consequential damages, secondary charges, expenses for installing or disconnecting, or losses to persons or property resulting from any failure of the product.

### 10.2 E-trAC X2C Series Options

Each of the following options connects to the J22 connector of the inverter (see Figure 9 on page 17 and Figure 10 on page 18 to locate J22), and allows communication distances of up to 300 feet. Each option package includes a 10-foot, coiled connection cable for easy interfacing to the inverter.

#### A. XRK01 - Remote Keypad Unit

The XRK01 - Remote Keypad Unit (RKU) is a portable, hand-held accessory. When connected to an E-trAC X2C Series inverter, it will function in parallel with an existing keypad or allow a chassis model to be controlled and programmed. The RKU is powered by a 9 V alkaline battery (supplied) or an optional AC adapter (PA24DC). Auto Power Down and backlight control features conserve battery life by automatically turning the RKU off after a specified time period and allowing selected use of the display backlight.

#### B. XPM01 - Program Memory Unit

The XPM01 - Program Memory Unit (PMU) is another portable, hand-held accessory. When connected to an E-trAC X2C Series inverter with software revision 13.1 or greater, it allows operation and programming like the RKU. In addition, it allows up to ten different parameter sets to

## Section 10: Options and Replacement Parts

be stored internally, any one of which can be downloaded to the inverter's active memory or customer parameter set. Uploading parameter sets from an inverter to a PMU memory location is also possible.

The PMU is powered by a 9 V alkaline battery or the AC adapter (both supplied). Auto Power Down and backlight control features conserve battery life by automatically turning the PMU off after a specified time period and allowing selected use of the display backlight.

### C. XRP01 - Remote Panel Keypad

The XRP01 Remote Panel Keypad is a NEMA 4 rated, panel-mountable accessory. When properly installed, the XRP01 seals into the host enclosure, assuring that the NEMA 4 integrity is preserved. When connected to an E-trAC X2C Series inverter, it will function in parallel with the existing keypad to allow the inverter to be controlled and programmed. The XRP01 is self-powered and can be powered by an optional external AC adapter (PA24DC) or a customer supplied +24VDC source.

### D. XRP02 - Remote Panel Programmer

The XRP02 Remote Panel Programmer is a NEMA 4 rated, panel-mountable accessory. When properly installed, the XRP02 seals into the host enclosure, assuring that the NEMA 4 integrity is preserved.

When connected to an E-trAC X2C Series inverter with software revision 13.1 or greater, it allows operation and programming like the XRP01. In addition, it allows up to ten different parameter sets to be stored internally, any one of which can be downloaded to the inverter's active memory or customer parameter set. Uploading parameter sets from an inverter to an on-board memory location is also possible.

The XRP02 is self-powered and can be powered by an optional external AC adapter (PA24DC) or a customer supplied +24VDC source.

## 10.3 WDBxxx External Dynamic Braking Package

The WDBxxx assemblies are designed to increase the capacity of E-trAC X2C 7.5 to 20 HP models to absorb regenerated energy from a rapidly decelerated motor or an overhauling load. The WDB211 is designed to connect any 230 VAC X2C 7.5 to 20 HP model and provides 10 HP of braking capacity at 10% duty cycle. Similarly, the WDB411 is intended for use with 460 VAC models 7.5 to 20 HP.

**Section 10: Options and Replacement Parts**

**10.4 Replacement Parts - 0.5 to 5 HP Models**

Description	Part No.	1000-5	1001-0	2000-5	2001-0	2002-0	2003-0	2005-0	4001-0	4002-0	4003-0	4005-0
<b>Cover for "B" Enclosure Style Models (with keypad)</b>	X2CC0V1R	1		1	1				1			
	X2CC0V2R		1			1				1		
	X2CC0V5R						1	1			1	1
<b>Cover for "E" Enclosure Style Models (without keypad)</b>	X2CC0V3R	1		1	1				1			
	X2CC0V4R		1			1				1		
	X2CC0V6R						1	1			1	1
<b>Terminal Access Cover</b>	U1194R	1		1	1				1			
	U1196R		1			1				1		
	U1188R						1	1			1	1
<b>Cooling Fan</b>	XFAN5HP						1	1			1	1
<b>Ground Fault CT</b>	U9708R	1	1	1	1	1	1	1	1	1	1	1

## Section 10: Options and Replacement Parts

### 10.5 Replacement Parts - 7.5 to 20 HP Models

Description	Part Number	2007-5	2010-0	2015-0	2020-0	4007-5	4010-0	4015-0	4020-0
Control Board	PC440-207	1							
	PC440-210		1						
	PC440-215			1					
	PC440-220				1				
	PC440-407					1			
	PC440-410						1		
	PC440-415							1	
	PC440-420								1
Power Card	PC469	1							
	PC470		1						
	PC471			1					
	PC472				1				
	PC465					1			
	PC466						1		
	PC467							1	
	PC468								1
Capacitor Board	PC274	1							
	PC275		1						
	PC276			1					
	PC277				1				
	PC278					1			
	PC279						1		
	PC280							1	
	PC281								1
Power Supply	PSMOD01	1	1	1	1				
	PSMOD02					1	1	1	1
DB Resistor	XDB2010	1	1						
	XDB2020			1	1				
	XDB4010					1	1		
	XDB4020							1	1
Cooling Fan	XFAN20HP	2	2	2	2	2	2	2	
Cover	X2CCOV7R	1	1	1	1	1	1	1	
Rectifier Module	E56205R	1							
	E56206R		1	1					
	E56214R				1				
	E56204R					1	1		
	E56207R							1	1

(continued)

**Section 10: Options and Replacement Parts**

Description	Part Number	2007-5	2010-0	2015-0	2020-0	4007-5	4010-0	4015-0	4020-0
Transistor Module	U8590R	3	3						
	U8592R			3					
	U8594R				3				
	U8591R					3	3		
	U8593R							3	3

**Section 10: Options and Replacement Parts**

## Appendix A: Summary of X2C Parameters

This appendix provides two sections. The first section provides a table that summarizes the parameters available when PI control is not utilized. The second section (starting on page 4) summarizes the parameters that are added or amended when PI control is enabled.

### A.1 Summary of X2C Parameters When PI Control Is Not Utilized

Parameter		Level	Range (Default)	User Setting	See Page
02-RVLVL	Software Revision	L2	—	Read-Only	50
03-IRAT	Inverter Rated Current	L2	—	Read-Only	50
07-FLT3	Last Fault	L1	—	Read-Only	50
08-FLT2	Second Fault	L2	—	Read-Only	50
09-FLT1	First Fault	L2	—	Read-Only	50
12-FOUT	Motor Output Frequency	L1	0-400 Hz	Read-Only	50
13-VOUT	Motor Output Voltage	L1	0-100%	Read-Only	50
14-IOUT	Motor Output Current	L1	0-60 A	Read-Only	50
15-LOAD	Inverter Load	L1	0-200% of 03-IRAT	Read-Only	50
17-TEMP	Inverter Temperature	L1	0-110 °C	Read-Only	50
21-MODE	Input Mode	L1	0-11 (0)		52
24-FSEL	Speed Setpoint Selector	L2	0-3 (0)		53
31-FMIN	Minimum Frequency	L1	0-400 Hz (0 Hz)		53
32-FMAX	Maximum Frequency	L1	20-400 Hz (60 Hz)		53
33-F2	Preset Frequency 2	L2	0-400 Hz (0 Hz)		54
34-F3	Preset Frequency 3	L2	0-400 Hz (20 Hz)		54
35-F4	Preset Frequency 4	L2	0-400 Hz (40 Hz)		54
36-F5	Preset Frequency 5	L2	0-400 Hz (60 Hz)		54
37-F6	Preset Frequency 6	L2	0-400 Hz (0 Hz)		54
38-F7	Preset Frequency 7	L2	0-400 Hz (0 Hz)		54
39-FTL	Min. Frequency When Torque Limit Active	L2	0-400 Hz (10 Hz)		54
41-RSEL	Ramp Selector	L2	0-7 (0)		55

## Appendix A: X2C Parameter Summary

Parameter		Level	Range (Default)	User Setting	See Page
42-ACC1	Acceleration Time 1	L1	0.1-600.0 s (3.0 s)		55
43-DEC1	Deceleration Time 1	L1	0.1-600.0 s (3.0 s)		55
44-ACC2	Acceleration Time 2	L2	0.1-600.0 s (1.0 s)		55
45-DEC2	Deceleration Time 2	L2	0.1-600.0 s (1.0 s)		56
46-DECTL	Deceleration Time When Torque Limit Active	L2	0.1 - 30 s (1.0 s)		56
47-DCBRK	DC Brake Time	L2	0.0 - 5.0 s (0.2 s)		57
48-DCVLT	DC Brake Voltage	L2	0-15% of input voltage		57
5B-MSAT	Motor Saturation	L2	15-85%		58
51-VSEL	V/Hz Characteristic Selector	L2	0-5 (0)		58
52-BOOST	Torque Boost	L1	0-25% of nominal voltage		59
53-FKNEE	V/Hz Knee Frequency	L2	26-960 Hz (60 Hz)		59
54-SKBND	Skip Frequency Band	L2	0.2-20.0 Hz (1 Hz)		59
55-SK1	Skip Frequency 1	L2	0.0-400.0 Hz (0 Hz)		60
56-SK2	Skip Frequency 2	L2	0.0-400.0 Hz (0 Hz)		60
57-SK3	Skip Frequency 3	L2	0.0-400.0 Hz (0 Hz)		60
59-MVOLT	Rated Motor Voltage	L2	185-240 VAC 370-480 VAC		60
61-LTLF	Preset Limit for Torque Load (Forward)	L2	30-150% (150%)		60
62-LTLR	Preset Limit for Torque Load (Reverse)	L2	30-150% (150%)		60
63-RTL F	Preset Limit for Regenerative Torque (Forward)	L2	30-110% (80%)		60
64-RTL R	Preset Limit for Regenerative Torque (Reverse)	L2	30-110% (80%)		60
65-SLIP	Slip Compensation	L1	0-12% (0%)		60
66-STAB	Current Stability	L2	0-4 (3)		61

## Appendix A: X2C Parameter Summary

Parameter		Level	Range (Default)	User Setting	See Page
67-TOL	Timed Overload Trip Pt.	L1	0-100% (0%)		61
6A-TOLC	Timed Overload Characteristic	L2	0-7 (0)		62
68-NRST	Trip Restart - Number of Attempts	L2	0-8 (0)		63
69-DRST	Trip Restart - Time Delay	L2	0-60 s (0 s)		63
70-MCAL	Analog Meter Output (MET1) Calibration	L1	0-255 VDC (set for 10 VDC)		63
71-METER	Analog Meter Output (MET1) Selector	L1	0-3 (1)		64
72-ST1	Digital Output ST1	L1	0-10 (7)		65
75-STR	Digital Output RCM	L1	0-10 (2)		65
77-MOL	Motor Overload Input	L2	0-3 (0)		66
78-MCAL2	Analog Meter Output (MET2) Calibration	L1	0-20mA or 4-20 mA (set for 20 mA)		66
79-MET2	Analog Meter Output (MET2) Selector	L1	0-4, 11-14 (3)		67
81-PRGNO	Special Program	L2	0-3, 80-95 (0)		67
82-START	Start Options	L2	0-7 (0)		68
83-PWM	PWM Carrier Frequency	L2	0-5 (1)		69
84-DISP	Display Option Setting	L2	0-3000 (0)		71
87-ACODE	Security Access Code	L2	0-999 (0)		71
97-RVLVL2	Software Revision Level 2	L2		Read-Only	71
C0-VINSPAN	Span Adjustment for VIN1	L2	7000 - 9999 (8950)		72
C1-MET2OFS	Offset Adjustment for MET2	L2	0 - 255 (180)		72

## Appendix A: X2C Parameter Summary

### A.2 Parameters Added or Amended When PI Control Is Utilized

The following table lists the parameters that become available when PI control is enabled by setting parameter 81-PRGNO to a value between 80 and 95 (see page 81). It also lists those parameters where data codes change due to the enabling of PI control. For further information on PI control, see Section 8 starting on page 73.

Parameter	Level	Range (Default)	User Setting	See Page	
<b>Parameters That Are Added When PI Control Is Enabled</b>					
1A-FSTAT	Stator Frequency	L2	—	Read-Only	78
A1-FCORR	Frequency Correction	L2	0.0 to 400.0 Hz		78
A6-ERROR2	Final Error	L2	—	Read-Only	78
A7-ERROR1	Initial Error	L2	—	Read-Only	78
A8-SIPART	Integral Sum	L2	—	Read-Only	78
B3-KP	Proportional Gain	L2	0 to 255		78
B4-KI	Integral Gain	L2	0 to 255		78
B5-KIN	VIN2 Gain	L2	0 to 255		78
<b>Parameters That Are Amended When PI Control Is Enabled</b>					
21-MODE	Input Mode	L1	If PS3 is used for on/off control, preset speed switch and jog/run are not available.		79
24-FSEL	Speed Setpoint Selector	L2	Four data codes area added; range is now 0-3, 16-19.		79
41-RSEL	Ramp Selector	L2	If PS3 is used for on/off control, Alternate Ramp Time (ART) is not available. Range is now 0-2, 4-6 (data codes 3 & 7 are disabled).		79
65-SLIP	Slip Compensation	L1	This parameter is disabled.		80
71-METER	Analog Meter Output (MET1) Selector	L1	Data code 5 is added; the range is now 0-5.		80
79-MET2	Analog Meter Output (MET2) Selector	L1	Two data codes are added; the range is now 0-5 and 11-15.		80
81-PRGNO	Special Program	L2	Data codes 80-95 added to select type of PI control desired.		81

---

## **Appendix B: EU Declaration of Conformity - 00**

This appendix contains the TB Wood's Declaration of Conformity for the X2C series of products. The Declaration appears on the next page.



TB Wood's Incorporated  
440 North Fifth Avenue  
Chambersburg, Pennsylvania 17201-1778  
717.264.7161 tel 717.264-6420 fax

#### EU DECLARATION OF CONFORMITY - 00

WE: TB Wood's Incorporated  
440 North Fifth Avenue  
Chambersburg, PA 17201  
USA

hereby declare that the products:

Product Name: X2C Series  
Model Number: X2C10005, X2C10010, X2C20005,  
X2C20010, X2C20020, X2C20030,  
X2C20050, X2C20075, X2C20100,  
X2C20150, X2C20200, X2C40010,  
X2C40020, X2C40030, X2C40050,  
X2C40075, X2C40100, X2C40150,  
X2C40200

have been designed and manufactured in accordance with standards:

Low Voltage Directive:  
EN50178 - Electronic equipment for use in power installations

Electromagnetic Compatibility:  
EN50081-1 - Adjustable speed electrical power drive systems  
Part 3: EMC product standard including specific test methods

The products referenced above are for the use of control of the speed of AC motors.

For application information, consult the following document from TB Wood's: Form 1247.

Via internal mechanisms and Quality Control, it is verified that these products conform to the requirements of the Directive and applicable standards.

Chambersburg, PA, USA - 1 December 2000

Rick Kirkpatrick  
Director of Marketing  
Electronics Division

## Publication History

Date	Nature of Change
March 1998	First release of Form 1247.
April 1998 Revision A	<p>Revised drawing of 0.5 to 5 HP inverters (Figure 9 on page 17) to include Ground Fault CT and made necessary textual changes to support the drawing (Sections 4.2 and 4.8). Also revised the drawing in Figure 12 on page 28 to agree with the new drawing.</p> <p>Added tightening torque values to Table 9 on page 18.</p> <p>Clarified the operation of PS1, PS2, and PS3 in Table 10 in Section 4.3.</p> <p>Clarified and corrected the use of J20 jumpers in several places. Also changed the input impedance values for VIN1 and VIN2 in Section 4.4 on page 22.</p> <p>Added a new Fault Code (F15) on page 85.</p> <p>Corrected the replacement parts table on page 89, and added a Ground Fault CT.</p> <p>Amended the tables of Appendix A to include a column for user's settings.</p> <p>Made minor corrections as needed for typographical errors.</p>
September 1998 Revision B	<p>REF Terminal Voltage changed from 5.2 VDC to 5.0 VDC.</p> <p>Default values of parameters <b>66-STAB</b>, <b>72-ST1</b>, <b>79-MET2</b>, &amp; <b>84-DISP</b> updated.</p> <p>Recommended Fuse added for X2C4005-0x.</p> <p>JKS Type fuses specified as alternates for KTK Type fuses for X2C2007-5x and X2C4015-0x.</p> <p>Added note #4 on Figure 12 regarding use of External Motor Thermal Overloads.</p>
February 1999 Revision C	Minor update to Section 5.
December 2000 Revision D	Minor update to Appendix B - CE Declaration of Conformity and Chapter 5 - EMC Compatibility.
February 2001 Revision E	Update to added 81-PRGNO = 101 function, C0-VINSPAN and C1-MET2OFST.



---

**TB Wood's Incorporated**      <http://www.tbwoods.com>  
440 North Fifth Avenue  
Chambersburg, Pennsylvania 17201-1778  
Telephone: 888-TBWOODS or 717-264-7161  
Direct Dial (Sales) 717-267-2900  
FAX: 717-264-6420

**T. B. Wood's Canada Ltd.**  
750 Douro Street  
Stratford, Ontario, Canada N5A 6V6  
Telephone: 519-271-5380  
FAX: 519-271-3094

**TB Wood's (México) S.A. de C.V.**  
Oriente 237 No. 171  
Colonia Agrícola Oriental  
08500 México, D.F.  
Telephone: 5-558-16-20  
FAX: 5-756-06-74

**Plant Engineering Consultants**  
(Wholly-owned subsidiary)

521 Airport Road  
Chattanooga, Tennessee 37421  
Telephone: 800-437-3311 or 423-892-7654  
FAX: 423-894-0495

---

## Distribution Centers

**ATLANTA**

700 Distribution Drive  
Atlanta, Georgia 30336  
Telephone: 800-789-6637  
FAX: 717-264-6420

**EDMONTON**

9779-45th Avenue  
Edmonton, Alberta, Canada T6E 5V8  
Telephone: 403-439-7979  
FAX: 403-439-7661

**CHICAGO**

1900 Touhy Avenue  
Elk Grove Village, Illinois 60007  
Telephone: 847-439-3788  
FAX: 847-439-0478

**RENO**

4970 Joule Street  
Reno, Nevada 89502  
Phone: 775-857-1800  
FAX: 775-857-1822

**DALLAS**

1151 Empire Central  
Dallas, Texas 75247  
Telephone: 214-637-0850  
FAX: 214-637-0867

**MONTREAL**

1073 Begin Street  
Ville St. Laurent  
Montreal, Quebec, Canada H4R 1V8  
Telephone: 514-332-4812  
FAX: 514-332-6842

---

## Other Wood's Locations

Mt. Pleasant, MI • San Marcos, TX • Trenton, TN