



**E-TRAC<sup>®</sup>**  
**WFC<sup>HT</sup>**  
**AC Inverter**

WFC1000 Series – 1 HP

WFC2000 Series – FHP to 25 HP

WFC4000 Series – 1 to 75 HP

Installation, Operation and  
Maintenance Instructions  
for CE Marked Version



**TB WOOD'S INCORPORATED**  
Chambersburg, Pennsylvania



**Program Code Summary (Level 1-2)**

#	Name	Description	Data Range	Factory Setting	Units	Access Level	See Page	Customer Setting
01	MODEL	Model Number	0-65000	Note 1	---	1	25	
02	RVLVL	Software Revision	0-640	Note 1	---	2	25	
03	IRAT	Rated Current	2-200	Note 1	A	2	25	
05	SERNO	Serial Number	0-65000	---	---	2	25	
06	REP	Repair Date	0-65000	---	---	2	25	
07	FLT3	Last Fault	---	---	---	1	25	
08	FLT2	2nd Fault	---	---	---	2	25	
09	FLT1	1st Fault	---	---	---	2	25	
12	FOUT	Output Frequency	0-400	---	Hz	1	25	
13	VOUT	Output Voltage	0-100	---	%	1	25	
14	IOUT	Output Current	0-650	---	A	1	26	
15	LOAD	Drive Load	0-200	---	%	1	26	
16	TORQ	Load Torque	0-200	---	%	1	26	
17	TEMP	Inverter Temp	2-105	---	C	1	26	
18	TIME1	Total Run Time	0-65000	---	h	2	26	
19	TIME2	Power On Hours	0-65000	---	h	2	26	
1B	FLUX	Magnetizing Current	0-100	---	%	2	26	
21	MODE	Input Mode	0-36	0	---	1	26 & 27	
24	FSEL	Reference Select	0-19	0	---	2	27	
27	TLSEL	Torque Limit Select	0-6	0	---	2	28	
31	FMIN	Min. Frequency	0.00-400	0	Hz	1	28	
32	FMAX	Max. Frequency	20.00-400	60	Hz	1	28	
33	F2	Preset Speed #2 - Jog	0.00-400	5	Hz	1	28	
34	F3	Preset Speed #3	0.00-400	20	Hz	2	28	
35	F4	Preset Speed #4	0.00-400	40	Hz	2	28	
36	F5	Preset Speed #5 (Note 2)	0.00-400	60	Hz	2	28	
37	F6	Preset Speed #6 (Note 2)	0.00-400	0	Hz	2	28	
38	F7	Preset Speed #7 (Note 2)	0.00-400	0	Hz	2	28	
39	FTL	Min. Frequency in Torque Limit	0.00-400	10	Hz	2	29	
41	RSEL	Ramp Selector	0-7	0	---	2	29	
42	ACC1	Acceleration Time #1	0.10-600	3	s	1	29	
43	DEC1	Deceleration Time #1	0.10-600	3	s	1	29	
44	ACC2	Acceleration Time #2	0.10-600	1	s	2	29	
45	DEC2	Deceleration Time #2	0.10-600	1	s	2	29	
46	DECTL	Torq. Limit Response Time	0.10-30	1	s	2	29	
47	DCBRK	DC Brake Time	0-5	0.2	s	2	29	
48	DCVLT	DC Brake Voltage	0-15	Note 1	%	2	30	
51	VSEL	V/Hz Characteristic Selector	0-6	0	---	2	30	
52	BOOST	Torque Boost	0-25	Note 1	%	1	30	
53	FKNEE	V/Hz Knee Frequency	26-640	60	Hz	2	31	

**Program Code Summary (Con.'t.)**

#	Name	Description	Data Range	Factory Setting	Units	Access Level	See Page	Customer Setting
54	<b>SKBND</b>	Skip Freq. Hysteresis Band	0.20-20	1	Hz	2	31	
55	<b>SK1</b>	Skip Frequency #1	0.00-400	0	Hz	2	31	
56	<b>SK2</b>	Skip Frequency #2	0.00-400	0	Hz	2	31	
57	<b>SK3</b>	Skip Frequency #3	0.00-400	0	Hz	2	31	
58	<b>SK4</b>	Skip Frequency #4	0.00-400	0	Hz	2	31	
59	<b>MVOLT</b>	Rated Motor Voltage	185-480	Note 1	V	2	31	
5B	<b>IMAG</b>	Rated Magnetizing Current	15-85	Note 1	%	2	31	
61	<b>LTLF</b>	Load Torque Limit Forward	5-150	150	%	2	31	
62	<b>LTLR</b>	Load Torque Limit Reverse	5-150	150	%	2	31	
63	<b>RTL F</b>	Regenerative Torq. Limit FWD	5-110	80	%	2	31	
64	<b>RTL R</b>	Regenerative Torq. Limit REV	5-110	80	%	2	31	
65	<b>SLIP</b>	Slip Compensation	0-10	0	%	1	32	
66	<b>STAB</b>	Current Stability	0-4	2	---	2	32	
67	<b>TOL</b>	Timed Overload Trip Point	0-100	0	%	1	32	
68	<b>NRST</b>	Restart Number	0-8	0	---	2	33	
69	<b>DRST</b>	Restart Delay	0-60	0	s	2	33	
6A	<b>TOLC</b>	Timed Overload Characteristic	0-7	0	---	2	33	
70	<b>MCAL</b>	Meter Calibration	0-255	Set to 10VDC	---	1	33	
71	<b>METER</b>	Analog Meter Output	0-7	1	---	1	33	
72	<b>ST1</b>	Auxiliary Output #1	0-11	6	---	2	34	
73	<b>ST2</b>	Auxiliary Output #2	0-11	3	---	2	34	
74	<b>ST3</b>	Auxiliary Output #3	0-11	7	---	2	34	
75	<b>STR</b>	Auxiliary Relay (Fault)	0-11	2	---	1	34	
77	<b>MOL</b>	Motor Overload Input	0-1	0	---	2	34	
81	<b>PRGNO</b>	Special Program Number	0-65000	0	---	2	34-39	
82	<b>START</b>	Inverter Start Options	0-7	0	---	2	39	
83	<b>PWM</b>	Carrier Frequency Selector	0-8	1	---	2	40	
84	<b>DISP</b>	Display Option Full Setting	0-65000	0	---	2	42	
85	<b>UNITS</b>	Display Units	ALPHA	RPM_1	---	2	42	
86	<b>LANG</b>	Display Language	0-3	0	---	2	43	
87	<b>ACODE</b>	Security Access Code	0-999	0	---	2	43	
88	<b>FRO</b>	Frequency Reference Output	0-1	0	---	2	43	
A2	<b>RATIO</b>	Master Slave Speed Ratio (Note 2)	0-200	100	%	2	43	
B1	<b>OPTNO</b>	Option Board Number	0-6	0	---	2	43	
Cx	<b>CNTLx</b>	Event Control (1-9)	BINARY (8)	0	---	2	34-39	
Ex	<b>ECNTx</b>	Event Counts (1-9)	0-65535	0	---	2	34-39	

Notes: 1. Default value is model dependent.  
 2. Parameter adjustable while drive is in the run mode.

See Section 5 for parameters accessible in Level 3 (SIO control).

See page numbers.

# TABLE OF CONTENTS

	Page
<b>Section 1 – General Information</b>	
1.1 Preface .....	1
1.2 Inspection .....	1
1.3 Control Identification Number .....	1
1.4 Control Specifications .....	2
1.5 Input/Output Ratings .....	5
1.6 AC Inverter Fundamentals .....	6
1.7 Description of Operation .....	6
<b>Section 2 – Installation Instructions</b>	
2.1 Rules for Installation .....	7
2.2 Dimensional Data .....	8
2.3 Input AC Line Requirements .....	12
2.4 Inverter Watt Loss .....	13
2.5 Line Fuse or Circuit Breaker Sizing .....	13
2.6 Wiring Practices .....	13
2.7 Reducing Current Surges .....	14
2.8 Function and Use of Terminals .....	15
2.9 Environment Considerations .....	17
<b>Section 3 – Setup/Getting Started</b>	
3.1 General Information .....	18
3.2 Digital Keypad .....	18
3.3 Operation Mode .....	19
3.4 Program Mode .....	20
3.5 Status (LED) Indicators .....	20
3.6 Description of Displays .....	21
3.7 Operating Tips .....	23
3.8 Quick-Start – Running the Motor .....	23
3.9 High Torque Setup Procedure .....	24
<b>Section 4 – Level 1/Level 2 Parameters</b>	
4.1 Programming .....	25
4.2 Parameter Descriptions .....	25
<b>Section 5 – Level 3 Parameters</b>	
5.1 Program Code Summary .....	44
5.2 Programming .....	44
5.3 Parameter Descriptions .....	45
<b>Section 6 – Applications</b>	
6.1 Connection Diagrams .....	50
6.2 Options and Accessories .....	52
6.3 Application Hints .....	53
<b>Section 7 – Troubleshooting</b>	
7.1 Fault Codes .....	54
7.2 Troubleshooting .....	55
7.3 Maintenance and Inspection .....	56
7.4 Replacement Parts .....	57
<b>Section 8 – Appendix A</b>	
8.1 Additional Publications .....	59
8.2 Hassle Free Warranty .....	59
<b>Section 9 – Appendix B – RFI Suppression and WLF Line Filters</b>	
Section 1 .....	60
Section 2 .....	61
Section 3 .....	62
Section 4 .....	65
Section 5 .....	66
<b>Section 10 – Appendix C</b>	
CE Declaration of Conformity .....	68

# SECTION 1

## GENERAL INFORMATION

### 1.1 Preface

This manual contains the specifications, installation instructions, description of operation, and troubleshooting procedure for the WFC<sup>HT</sup> Series AC Inverters. Before installing the drive, read this manual carefully to ensure correct installation and maximum performance. The information contained herein is considered current with the release of version 4.2 (02-RVLVL) of the drive software.

### 1.2 Inspection

- Upon receipt of the product, unpack the AC inverter and carefully inspect for any damage sustained in transit (depression in the enclosure, damage to parts, missing parts). If damage is apparent, the freight or express agent should be notified within 15 days of receipt of the product and a request be made that he make an inspection of the merchandise; then a claim should be filed against the carrier. For UPS shipment damage, save the box and packing material and notify TB Wood's Incorporated immediately.
- Next remove the AC inverter cover, if supplied, and inspect for any loose screws, nuts, or connectors.
- Read the technical data plate and verify the correct horsepower size for the application and note the input voltage and current required for the inverter.
- If the inverter is to be stored for a long period of time, repack the inverter and store in a clean, dry place, free from direct sunlight or corrosive fumes, and in a location where the ambient temperature will not be less than -20° C (-4° F) nor more than 60° C (140° F).

### 1.3 Control Identification Number

A systematic numbering system is used to define all WFC<sup>HT</sup> models by torque output, input voltage rating, horsepower rating, and enclosure type. This model number appears both on the shipping carton label and the technical data label on the enclosure. A model number code is also accessible in the Level 1 programming mode. (Refer to Section 4.2.)

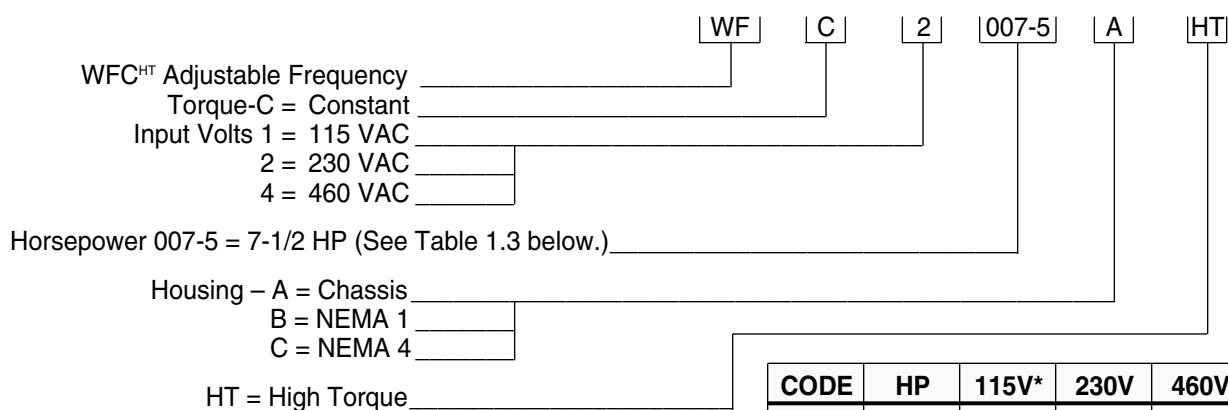

This control number describes a constant torque, WFC<sup>HT</sup> adjustable frequency control in a chassis configuration, rated 7.5 HP, with input voltage of 230 VAC.

The different horsepower ratings available and code for each rating are as follows:

CODE	HP	115V*	230V	460V
000-7	3/4		X	
001-0	1	X	X	X
002-0	2		X	X
003-0	3		X	X
005-0	5		X	X
007-5	7-1/2		X	X
010-0	10		X	X
015-0	15		X	X
020-0	20		X	X
025-0	25		X	X
030-0	30			X
040-0	40			X
050-0	50			X
060-0	60			X
075-0	75			X

TABLE 1.3

\*Input voltage, output voltage is 230 VAC 3 phase.

#### 1.4 WFC<sup>HT</sup> Series Control Specifications

	Model Series	WFC1000	WFC2000	WFC4000	See Page
<b>Applicable Motor Output</b>	Horsepower (HP) CT/VT	1	0.75-25	1-75/1-100	5
	Kilowatt (kW)	0.75	0.55-19	0.75-56	–
<b>Inverter Output Ratings @ 110% Motor Ratings</b>	Capacity (kVA)	1.6	1.2-30	1.5-196	5
	Continuous Amps	4.0	3-75	2-121	5
	Output Voltage (Source limited)	3.5-230 VAC 3 $\phi$	3.5-230 VAC 3 $\phi$	7.0-460 VAC 3 $\phi$	–
	Frequency Range	Programmable 0.1-400 Hz			28, 39
	Overload Capacity @ 40° C Ambient	150% for 60 Seconds 120% for 90 Seconds			32, 33
	Running Torque	150% at 2Hz			30
	Efficiency @ Rated Output	Greater than 95%			–
	<b>Inverter Input Ratings</b>	Input Voltage (3 $\phi$ inputs all 3-wire)	115 VAC 1 $\phi$	200-230 VAC 1 $\phi$ (FHP-2 HP) 200-230 VAC 3 $\phi$ (3-25 HP)	380-460 VAC 3 $\phi$
Voltage Tolerance		±10%	-10%; +15%		12
Input Current @ Maximum Rated Output (AC amperes)		9.7	4.8-95	2.2-152.8	5
KVA @ 50/60 Hz		1.2	1.1-38.1	1.8-122	5
Input Frequency		50/60 Hz ±10%			–
Phase Imbalance		2% maximum			12
<b>Control Specifications</b>		Control System	Sensorless Vector Pulse Width Modulation with Application Specific Integrated Circuit		
	Frequency Range	4000:1, 0.1-400 Hz (Programmable)			28, 31
	Frequency Command Selections	0-10 VDC or 0-2 VDC (100 k $\Omega$ ) 4-20 mA (237 $\Omega$ ) 0-1 kHz or 0-10 kHz pulse train Digital Keypad RS485 Serial Communication Link			15, 27
	Frequency Resolution	0.01 Hz			–
	Frequency Stability	Analog +0.2% 0-1 kHz pulse train +0.4% 0-10 kHz pulse train +0.1% Keypad +0.1% RS485 Port +0.1%			–
	V/Hz Ratio	Programmable using FKNEE function (0.01 Hz resolution) 230 VAC output models – 0.36 to 8.84 460 VAC output models – 0.72 to 17.69			31
	Acceleration/Deceleration Ramps	Programmable – 0.1 to 600 seconds to maximum frequency (primary and alternate available)			29
	Minimum Frequency	Programmable – 0.5 to 400 Hz (0.01 Hz increments)			28
	Maximum Frequency	Programmable – 20 to 400 Hz (0.01 Hz increments)			28
	Torque Limit	Four Quadrant Programmable – 5 to 150% torque (motoring mode); 5 to 110% torque (regenerative mode) Individual program settings for FWD run, FWD regen, REV run, & REV regen.			28, 31

TABLE 1.4

	Model Series	WFC1000	WFC2000	WFC4000	See Page
<b>Control Specifications (continued)</b>	Torque Limit Deceleration Rate	Programmable – 0.1 to 30 Seconds			29
	Minimum Frequency in Torque Limit	Programmable – 0.5 to 400 Hz			29
	Torque Boost	Programmable to suit requirements plus Autoboot			30
	Dynamic Braking	30-200% of drive rating (10 sec. max.) standard Consult factory for model specific data. Additional capacity available by adding external DB kits.			–
	Adjustments	Over 100 parameters can be monitored with over 80 user adjustments			–
	PWM Frequencies	Two settings available			39
	Agency Listing	UL® and cUL® Listed; CE Marked			–
<b>Protection Features</b>	Charge Indicator	Indicates the presence of potentially lethal bus voltage			15
	Ground Fault	All models fully protected			–
	Output Short Circuit (Line-to-Line)	All models fully protected			–
	Electronic Motor Overload	Programmable Inverse Time Overload Trip			32, 33
	Overvoltage Trip Level (on DC bus)	407 VDC		815 VDC	–
	Undervoltage Trip Level (on DC bus)	180 VDC		400 VDC	–
	Torque Limit	4 Quadrant – Independently Programmable			28, 31
	Program Lockout	User definable security access code			42
	Line Start Lockout	Prevents automatic startup when line power is applied (defeatable by programming)			39
	Overtemperature	Drive will shut down if heat sink temperature exceeds rating			–
	DB Failure	Drive will sense circuit failure and shut down			–
	Error/Fault Messages	19 fault codes 6 warning displays			53
	Fault Storage	Last three (3) faults stored. Most recent displayed.			25
	Line Transient Limit	2 KV. Maximum (less than 40 microsecond duration)			–
External MOL Contact	Compatible with NC fault contact			17	
<b>Operating Features</b>	Operating Controls	1. Keypad: Forward, Reverse, Jog, Stop, Program, Shift, Enter, Local/Remote and Up/Down Arrows.			18
		2. Terminal strip: See typical connection diagrams or consult factory.			16
		3. RS485 Serial Input/Output (SIO) Link.			43
	LED Indicators	Forward, Reverse, Jog, Stop, Bus Charged and CPU Active			20
Display	2 – lines of 16 characters, Back-Lit alphanumeric for all modes of operation. Programmable to display in English, French, Spanish or German. Any engineering units such as RPM, FPM, & GPM are supported.			21, 40	
Auxiliary Relay	Programmed as Fault Relay. Can be programmed to signal one of eleven conditions			17, 34	

TABLE 1.4 (Con't.)

	Model Series	WFC1000	WFC2000	WFC4000	See Page
<b>Programming</b>	Programming Levels	Level 1 – Operator    Level 2 – Engineer Level 3 – Engineer with SIO			25, 43
	Parameter Block 00 Drive Data	Model #, software revision, rated current, heat sink temp. trip point, mfg. serial #, repair date code, & fault log.			–
	Parameter Block 10 Status	Output frequency, voltage, motor current, motor load, torque, drive temperature, elapsed time since power applied, & total hours of operation.			–
	Parameter Block 20 Control	Definition of the LOCa/REMOte keypad button in reference to the keypad, terminal strip, & the SIO link. Also, various speed and torque references are contained within this block.			–
	Parameter Block 30 Frequencies	Various speed setpoints of the inverter.			–
	Parameter Block 40 Ramps	Ramp time selections (the time from start to maximum frequency FMAX or from FMAX to stop)			–
	Parameter Block 50 Voltage/Frequency Characteristics	V/Hz curves, boost, minimum frequency at full voltage, & skip frequencies.			–
	Parameter Block 60 Torque Limit	Torque limit setpoints, slip compensation, overload trip point, & auto-restart parameters.			–
	Parameter Block 70 I/O Definition	METer output, open collector output, & fault relay definitions.			–
	Parameter Block 80 Program Options	Storage & Retrieval of standard or custom programs, complete reset to factory settings, auto-restart, line start lockout, PWM selection, display of engineering units, alternate display languages, & customer access code storage.			–
	Parameter Block 90 RS485 Serial Link Options	BAUD or communication rate, slave address, watchdog timer, & retrieval of SIO generated fault codes.			–
	Parameter Block A0 Option Parameters	Speed Ratio & various parameters relative to the calibration of WPC option cards			–
	Parameter Block B0 Option Parameters	Option Board Identification and various parameters relative to the calibration of WPC option cards			–
	Parameter Block C0 Event Control Bytes	Used with program sequencer to control drive operation			35
	Parameter Block E0 Event Count Bytes	Used with program sequencer to control drive operation			35
<b>Construction</b>	Chassis, NEMA 1, NEMA 4	NEMA 4 standard thru 50/60 HP			–
<b>Mounting Location</b>	Chassis/NEMA 1	In separate enclosure protected from dust, moisture and corrosive fumes.			7
	NEMA 1	Indoor protected from dust, moisture and corrosive fumes			7, 17
	NEMA 4	Indoor protected from direct sunlight			7, 17
<b>Ambient Conditions</b>	Operating Temperature	Chassis – 0° C to 50° C    NEMA 1/4 – 0° C to 40° C			–
	Storage Temperature	-20° C to +60° C			–
	Humidity	90% RH or less, noncondensing (chassis controls)			–
	Vibration	0.6 G Maximum			–
	Elevation	Less than 3,300 feet without derating			–

TABLE 1.4 (Con't.)

## 1.5 WFC<sup>HT</sup> INPUT/OUTPUT RATINGS

WFC <sup>HT</sup> RATINGS BY MODEL NUMBERS									
Control Model Number WFC <sup>HT</sup>	HP	Ø (5)	INPUT RATINGS		MAXIMUM MOTOR RATINGS				
			CONTINUOUS		CONTINUOUS			1 MIN @ 40° C (3)	
	CT/VT		KVA (7)	AMP (1)	KVA	CT. AMPS (2)	VT. AMPS (2)	KVA	AMPS
1001-0	1/1	1	1.6	13.9	1.4	3.6	4.0	2.1	5.4
2000-7	0.75/0.75	1	1.4	6.1	1.1	2.8	3.1	1.7	4.2
2001-0	1/1	1	1.6	7.1	1.4	3.6	4.0	2.1	5.4
2002-0	2/2	1	3.3	14.4	2.7	6.8	7.5	4.1	10.2
2003-0	3/3	3	4.2	10.4	3.8	9.6	10.6	5.7	14.4
2005-0	5/5	3	7.0	17.6	6.1	15.2	16.7	9.1	22.8
2007-5	7.5/7.5	3	10.7	26.9	8.8	22.0	24.2	13.2	33.0
2010-0	10/10	3	13.6	34.2	11.2	28.0	30.8	16.8	42.0
2015-0	15/15	3	21.6	54.3	16.7	42.0	46.2	25.0	63.0
2020-0	20/20	3	27.2	68.2	21.5	54.0	59.4	32.3	81.0
2025-0	25/25	3	34.7	86.9	27.1	68.0	74.8	40.6	102.0
4001-0	1/1	3	1.8	2.2	1.6	2.0	2.2	2.4	3.0
4002-0	2/2	3	3.4	4.3	2.9	3.7	4.1	4.4	5.6
4003-0	3/3	3	4.9	6.2	4.4	5.5	6.1	6.6	8.3
4005-0	5/5	3	8.6	10.8	7.2	9.0	9.9	10.8	13.5
4007-5	7.5/10	3	12.8	16.0	10.4	13.0	14.3	15.5	19.5
4010-0	10/15	3	17.7	22.2	14.3	18.0	19.8	21.5	27.0
4015-0	15/20	3	24.7	31.0	19.1	24.0	26.4	28.7	36.0
4020-0	20/25	3	30.2	37.9	23.9	30.0	33.0	35.9	45.0
4025-0	25/30	3	39.7	49.8	31.1	39.0	42.9	46.6	58.5
4030-0	30/40	3	45.3	56.8	35.9	45.0	49.5	53.8	67.5
4040-0	40/50	3	61.4	77.1	48.6	61.0	67.1	72.9	91.5
4050-0	50/60	3	75.5	94.7	59.8	75.0	82.5	89.6	112.5
4060-0	60/75	3	90.0	112.0	71.0	90.0	98.0	106.4	133.5
4075-0	75/100	3	111.0	134.0	88.0	110.0	121.0	131.5	165.0

TABLE 1.5

### NOTES:

- (1) Required data for sizing input wiring.
- (2) CT Amps = Value stored in parameter 03-IRAT. Each model is capable of continuous operation at VT amps rating. Required data for sizing motor wiring.
- (3) For chassis models, ratings are for 1 minute @ +50°C. (40°C external ambient when enclosed.)
- (4) Control rated for 110% of motor rating (continuous).
- (5) For single phase applications greater than 5 HP, consult factory.
- (6) Motor thermal overload relay rating – 1.1 x continuous motor nameplate amps. (Necessary only in multi-motor applications.)
- (7) If the KVA rating of the power source exceeds ten times this value, the use of an isolation transformer or a line inductor is recommended.

## 1.6 AC Inverter Fundamentals

The principle of operation of the WFC<sup>HT</sup>, or any AC inverter, is to provide both an adjustable voltage and an adjustable frequency to the AC motor. The WFC<sup>HT</sup> automatically maintains the required volts/hertz ratio, allowing the AC motor to run at its optimum efficiency and providing rated torque capability throughout the motor's speed range. The basic formula that relates the output frequency to motor speed is:

$$N_s = \frac{120 \times f}{P}$$

$N_s$  = Synchronous Speed (RPM)  
 $f$  = Frequency (Hertz)  
 $P$  = Number of Poles in Motor

For Induction Motors:

$$\text{Motor RPM} = \text{Synchronous Speed} - \text{Motor Slip (RPM)}$$

The number of poles of a particular motor, and the amount of slip for a given load torque, are set by the motor's design and manufacturer.

## 1.7 Description of Operation

The primary functional blocks of the inverter are outlined in Figure 1.7.

The ultimate goal of any inverter is to accept fixed voltage and frequency from a power source and convert this power into variable voltage and frequency to control a three phase AC induction motor. The WFC<sup>HT</sup> does this and much more. It allows the user to interface into the very powerful electronics necessary to provide variable speed control of the motor, in a very friendly fashion.

Signals can be introduced to the terminal strip for full or partial control of the inverter. The powerful serial input output (SIO) link is available for total communication and programming. The keypad provides total control of programming and drive operation.

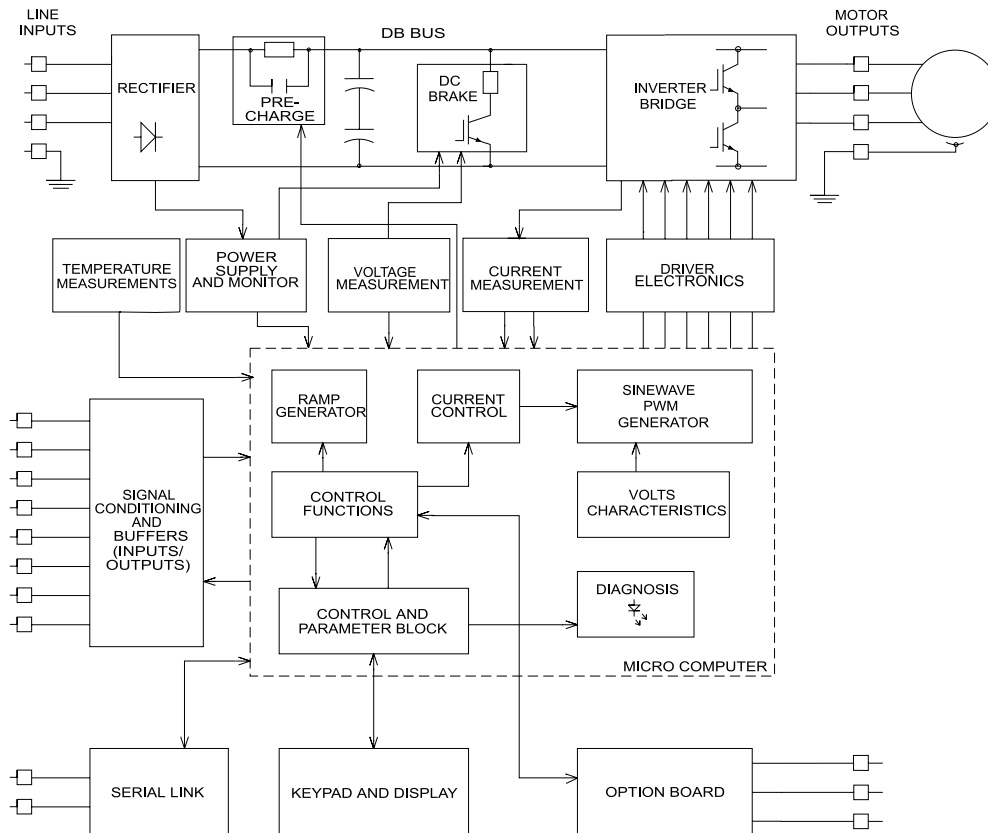

FIGURE 1.7

## SECTION 2

### INSTALLATION AND ENCLOSURE DIMENSIONS

#### 2.1 General Rules for Installation

Improper installation of the inverter will greatly affect its life. Be sure to observe the following points when selecting a mounting location.

- A. Do not install the inverter in a place subjected to high temperature, high humidity, or excessive vibration. (Consult Table 1.4 for temperature, humidity and maximum vibration limits.)
- B. Mount the unit vertically and do not restrict the airflow to the heat sink fins on the back of the control. The fan and fins allow cooling of internal components. Any air restriction could greatly reduce the life of the inverter, as well as resulting in nuisance over temperature trips.
- C. The WFC<sup>HT</sup> generates heat. Allow sufficient space around the unit, as shown in the illustration. If mounted in an enclosure with other equipment, be sure to allow at least five (5) inches of space on each side for adequate ventilation.
- D. For totally-enclosed chassis models (fins inside the enclosure), consult TB Wood's Incorporated for enclosure sizing and mounting instructions.
- E. Do not mount the WFC<sup>HT</sup> near heat generating equipment or in direct sunlight.
- F. Explosion proof Applications – Part of the criteria for an explosion proof rating is that the motor is designed and tested to ensure that its outer surface temperature does not exceed prescribed levels. These limits can be easily exceeded if the motor is operated from an AC inverter. A few manufacturers of explosion proof motors have received UL<sup>®</sup> certification for their products when used on AC inverters. These motors have very strict operating speed limits and other disclaimers to protect the companies in case an accident occurs involving their product. Explosion proof motors that are **not** rated for inverter use lose their certification when used for variable speed. Due to the many areas of liability that may be encountered when dealing with these applications, the following statement of Company Policy applies:

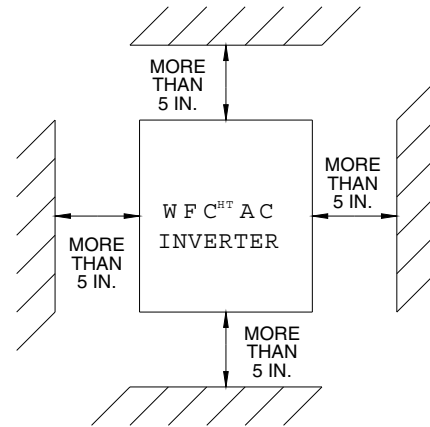

FIGURE 2.1

TB Wood's Incorporated AC Inverter products are sold for suitability with explosion proof AC motors rated for use with PWM inverters. These motors must be UL listed for use with either TB Wood's AC inverters or with PWM inverters and used within the specified speed ranges and carrier frequencies. TB Wood's accepts no responsibility for any direct, incidental or consequential loss, cost or damage associated with the misapplication of our AC products in these applications. In any misapplication, the purchaser expressly agrees to assume all risk of loss, cost or damage that may arise. TB Wood's Incorporated will not knowingly approve the application of their AC inverters with motors not rated for such applications.

- G. Line Starting – WFC<sup>HT</sup> is designed to provide controlled starting and stopping of AC motors by use of the keypad or external contacts connected to the control terminal strip. WFC<sup>HT</sup> may also be started by applying AC power to terminals L1, L2, and L3. The inverter has line-start-lockout as a standard feature, to prevent automatic starting when line power is applied. This provision can be defeated by appropriate programming. **The inverter may be started once every two minutes in this mode.**
- H. Chassis Model Installation -- The Chassis style WFC<sup>HT</sup> series is shipped with the keypad attached to the inverter, but it can be removed and attached to an enclosure front cover or remote station (See Section 6.2). **Note: CE specifications require that any system component housed within an enclosure, cannot have an attached operator control. Therefore, the keypad must be removed from the inverter and attached to an enclosure panel to maintain CE compliance in these cases.**

## 2.2 Dimensional Data

The following pages show the dimensional data for the NEMA 4 and chassis style WFC<sup>HT</sup> Inverters. Use this data and the General Rules for Installation to select a suitable mounting location.

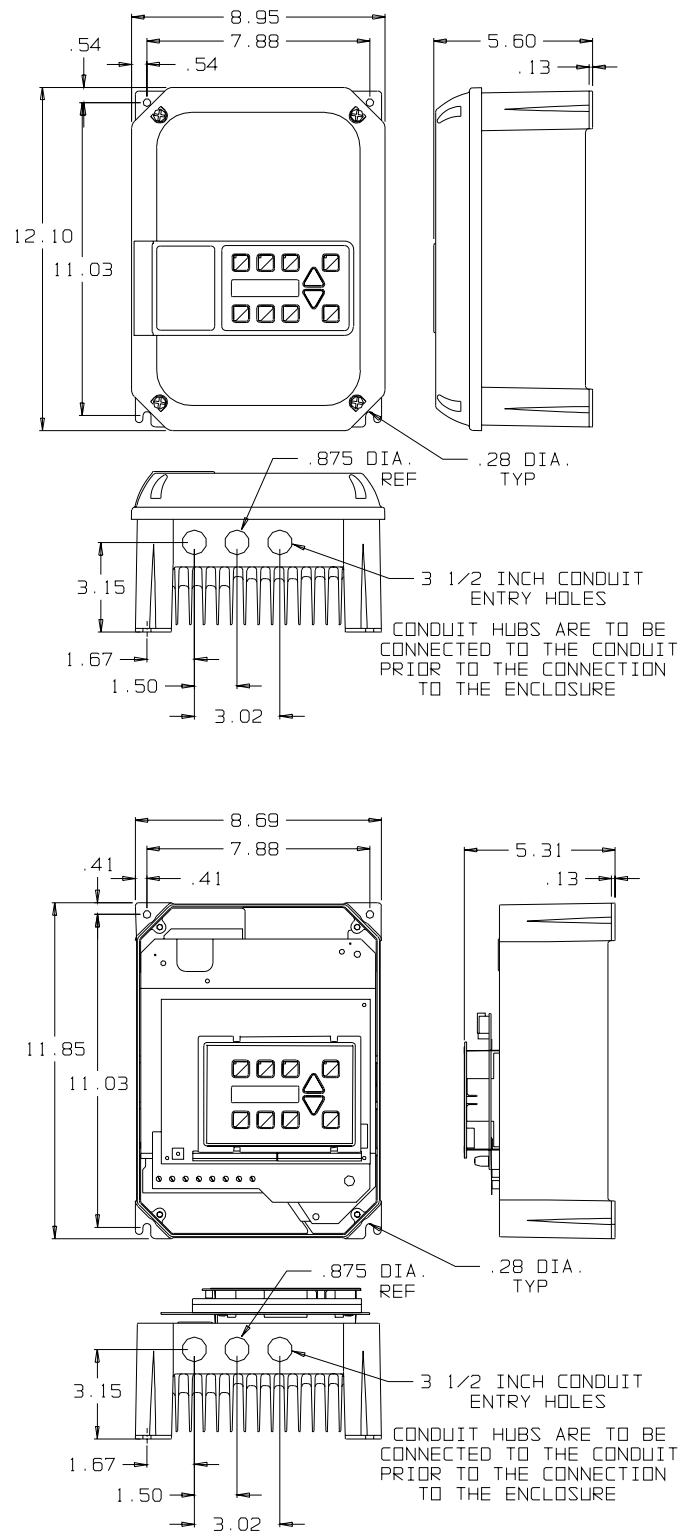

FHP-5 HP  
NEMA 4 & CHASSIS MODELS

FIGURE 2.2

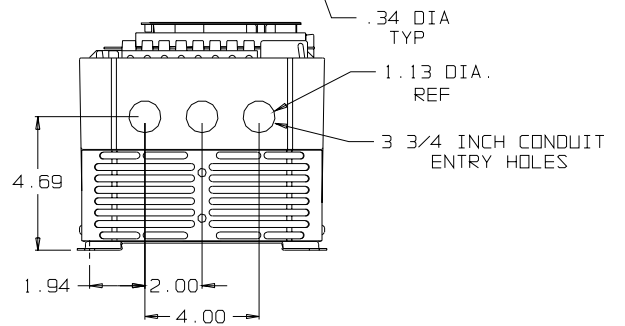
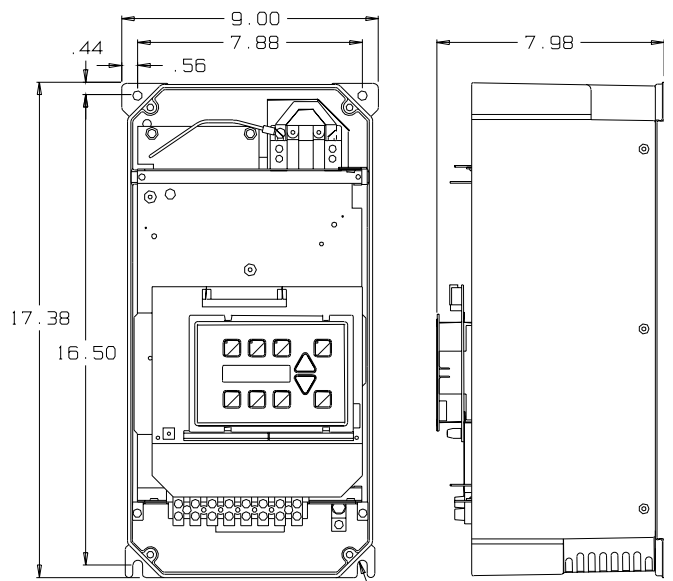
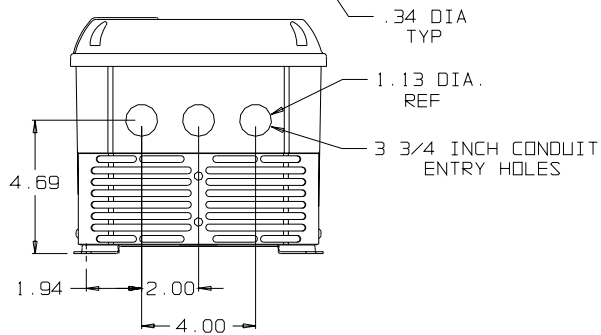
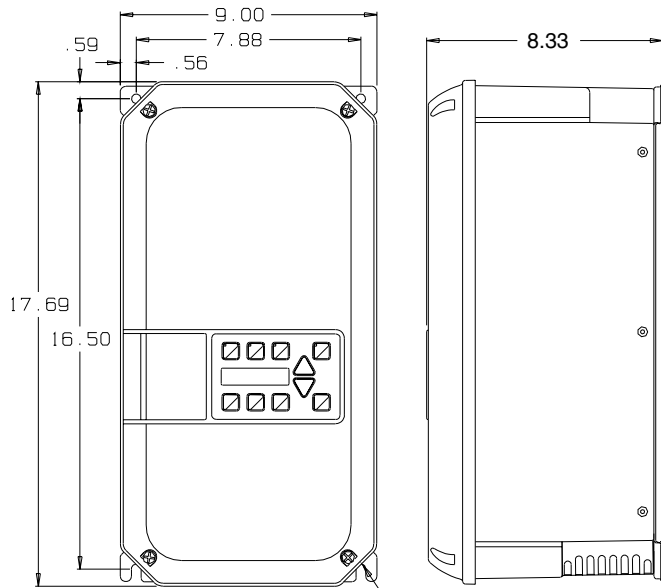

7.5-10 HP 230 VAC  
 7.5-20 HP 460 VAC  
 NEMA 4 & CHASSIS MODELS

FIGURE 2.3

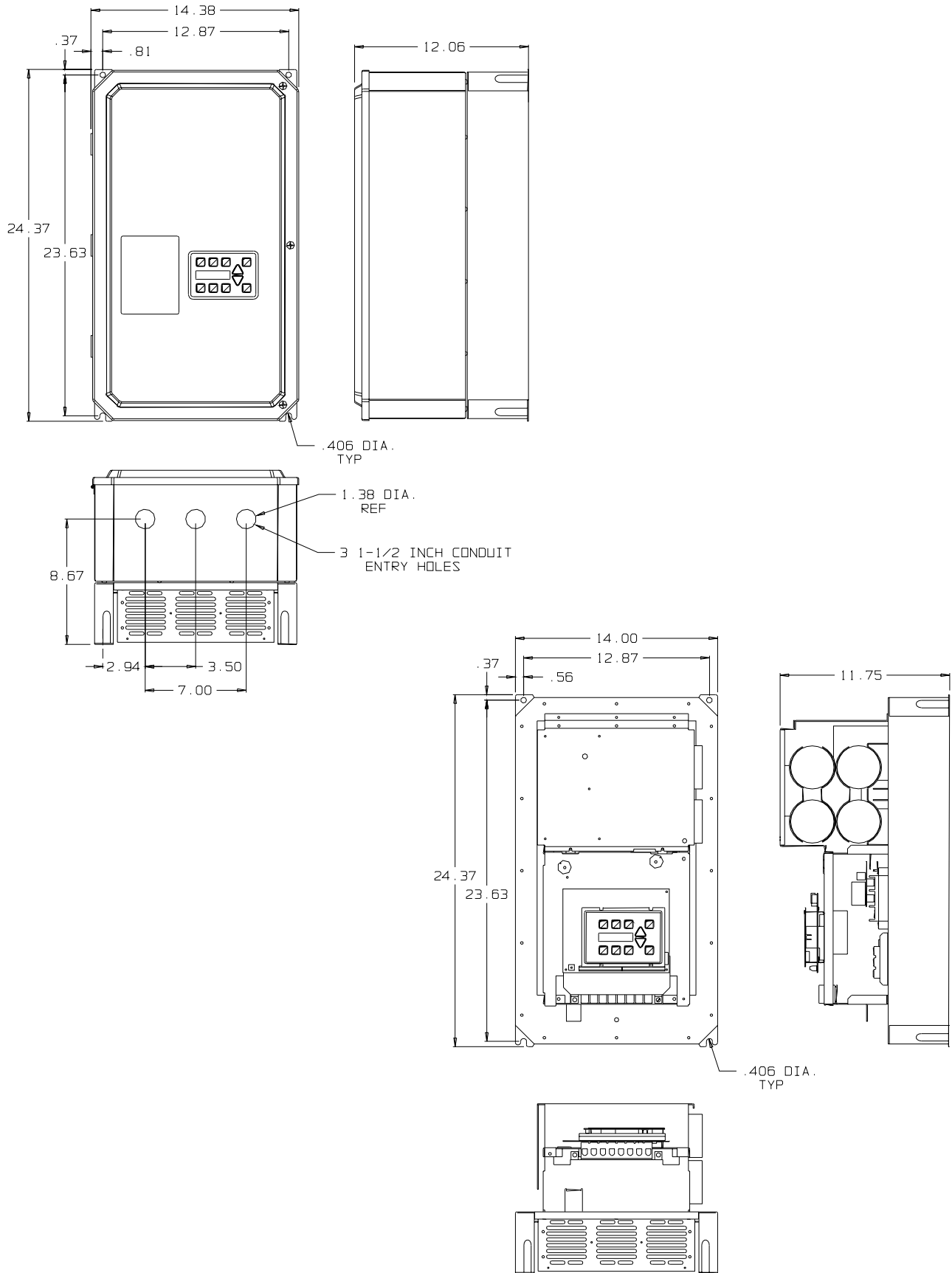

15-20 HP 230 VAC  
 25-30 HP 460 VAC  
 NEMA 4 & CHASSIS MODELS

FIGURE 2.4

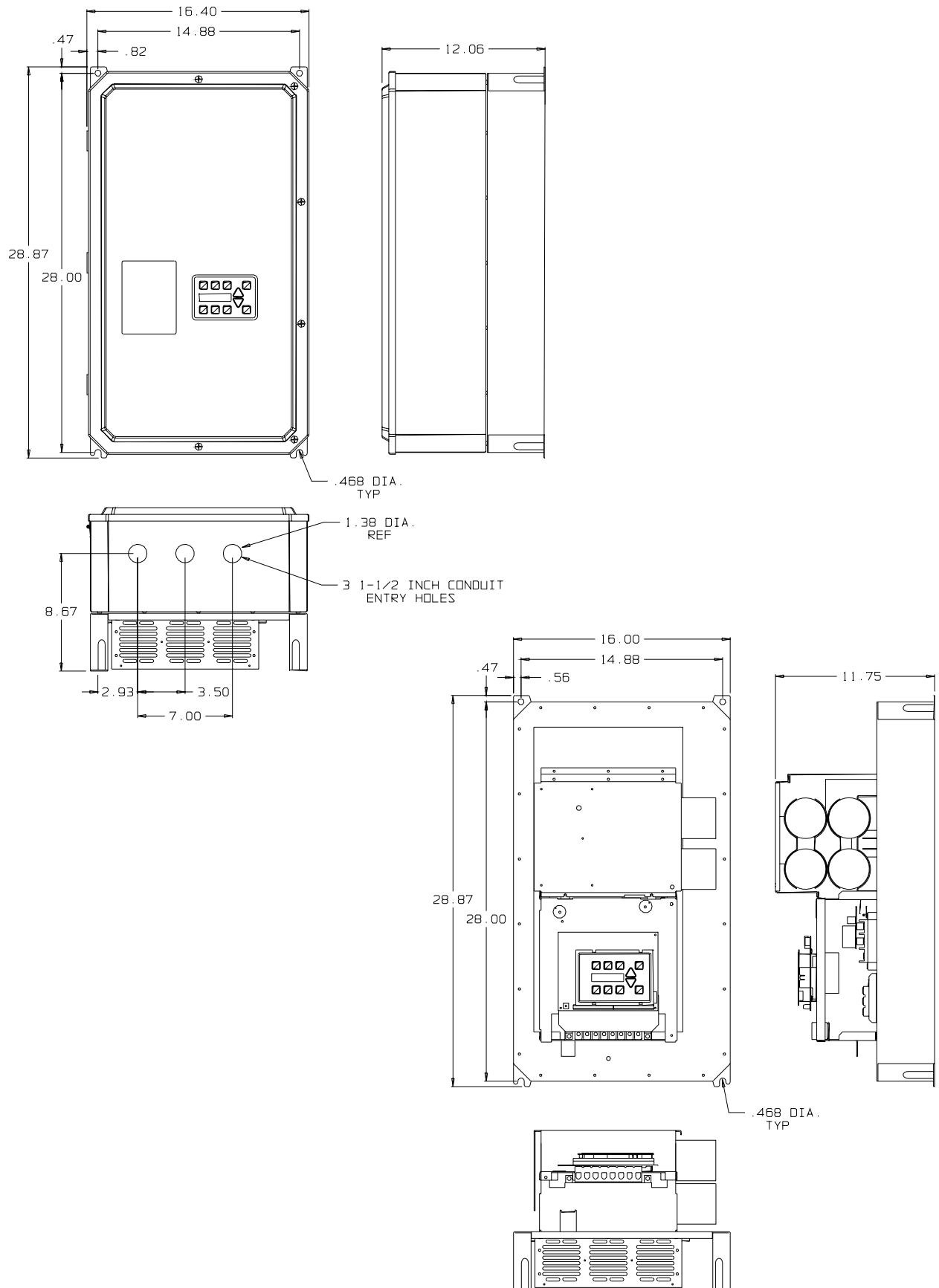

25 HP 230 VAC  
 40-75 HP 460 VAC (NEMA 1/NEMA 4 MODELS)  
 40-75 HP 460 VAC (CHASSIS MODELS)

FIGURE 2.5

## WARNING

DISCONNECT POWER BEFORE SERVICING THIS CONTROL.  
HAZARDOUS VOLTAGES EXIST UNTIL CHARGE LIGHT GOES OUT.

## AVERTISSEMENT

COUPER L'ALIMENTATION AVANT D'ENRENERORE LE DEPANNAGE DU SYSTEME ELECTRIQUE.  
VOLTAGE DANGEUREUX EXISTE TANT QUE LA LUMIERE INDICATRICE RESTE ALLUMÉ.

### 2.3 Input AC Line Requirements

The allowable AC line voltage fluctuation is -10% to +15% of nominal line voltage. A supply voltage above or below these limits could cause the inverter to trip out with either an overvoltage or an undervoltage fault.

NOTE:

Caution must be exercised when applying WFC<sup>HT</sup> Inverters on low line conditions.

		Input Power Transformer Rating													
Rated HP	FHP	1	2	3	5	7-1/2	10	15	20	25	30	40	50	60	75
Minimum KVA Rating	2	2	4	5	9	13	18	25	31	40	46	62	76	90	112

For example, a WFC2000 Series Inverter will operate properly on a 208 VAC line. However, the maximum output voltage will be limited to 208 VAC. If the motor is rated for 230 VAC line voltage, higher motor currents and increased heating will result. **Ensure that the voltage rating of the motor matches the applied line voltage.**

If other than 60 Hz output can be tolerated, proper volts/hertz can be programmed into the inverter by the 53-FKNEE and 32-FMAX parameters. If you are unsure about this feature, consult Section 4.2 or the factory.

Phase voltage imbalance of the input AC source can cause unbalanced currents and excessive heat in the input rectifier diodes and in the DC bus capacitors of the WFC<sup>HT</sup>. Phase imbalance is calculated by the following method:

Assume: The voltage from L1 to L2 = La  
The voltage from L2 to L3 = Lb  
The voltage from L1 to L3 = Lc  
The average line voltage = Lavg

$$L_{avg} = \frac{L_a + L_b + L_c}{3}$$

Determine the absolute value of the difference between each of the line voltages (La, Lb, & Lc) and Lavg. (Subtract the two values and disregard the sign of the result.) Consider the results of this calculation to be Laa, Lba, & Lca.

$$\text{Phase Imbalance (\%)} = \frac{L_{aa} + L_{ba} + L_{ca}}{2 (L_{avg})} \times 100\%$$

Example:

Measured phase voltages of 230, 235, & 240 would result in a calculated phase imbalance of 2.1%.

If the resulting phase imbalance exceeds 2%, consult your local power company or plant maintenance personnel and ask them to investigate this problem and recommend methods of correcting this condition.

Phase imbalance can be damaging to motors running Across-the-Line also. A 2% imbalance requires a 5% derating factor on the motor, 3% imbalance requires a 10% derating, 4% requires an 18% derating.

**CAUTION: NEVER USE POWER-FACTOR IMPROVEMENT CAPACITORS ON THE WFC<sup>HT</sup> MOTOR TERMINALS, M1, M2, AND M3, OR DAMAGE TO THE INVERTER'S SEMICONDUCTORS WILL RESULT.**

#### A. Single Phase Operation

Certain models of WFC<sup>HT</sup> series AC inverters are designed for single phase input. **The output is still 230 VAC, three phase; therefore, do not connect single-phase motors to the inverter's output terminals as damage may occur.**

Models WFC1001-0 (115 VAC), WFC2000-7 (230 VAC), WFC2001-0, and WFC2002-0 are designed specifically for single phase input. For other requirements, please contact the factory.

#### B. Line Starting

WFC<sup>HT</sup> is designed to provide controlled starting and stopping of AC motors by use of the keypad or external contacts connected to the control terminal strip. WFC<sup>HT</sup> may also be started by applying AC power to terminals L1, L2, and L3. The inverter has line-start-lockout as a standard feature, to prevent automatic starting when line power is applied. This provision can be defeated by appropriate programming. **The inverter may be started once every two minutes in this mode.**

## 2.4 Inverter Watt Loss

The operation of the inverter generates heat due to inefficiencies within the system. This heat must be accounted for when mounting the inverter within another enclosure. The following table shows the watts generated by the inverter when at full current and at various switching frequencies. For specific switching frequencies, use worst case scenarios or consult the factory.

Model Number	Amp Rating	Max. Switching Frequency at Max. Amp	Watt Loss at Default Switching	Watt Loss at Highest Switching
WFC20007xHT	3.1	16kHz	58	131
WFC20010xHT	4	16kHz	72	163
WFC20020xHT	7.5	16kHz	121	273
WFC20030xHT	10.6	8kHz	161	238
WFC20050xHT	16.7	8kHz	216	320
WFC20075xHT	24.2	16kHz	299	671
WFC20100xHT	30.8	16kHz	402	902
WFC20150xHT	48.2	16kHz	603	1353
WFC20200xHT	59.4	16kHz	712	1598
WFC20250xHT	74.8	16kHz	1005	2256
WFC40010xHT	2.2	16kHz	62	140
WFC40020xHT	4.1	16kHz	99	222
WFC40030xHT	6.1	16kHz	114	256
WFC40050xHT	9.9	8kHz	181	267
WFC40075xHT	14.3	16kHz	255	573
WFC40100xHT	19.8	16kHz	350	785
WFC40150xHT	26.4	16kHz	468	1051
WFC40200xHT	33	8kHz	608	900
WFC40250xHT	42.9	16kHz	752	1688
WFC40300xHT	49.5	16kHz	864	1940
WFC40400xHT	67.1	4kHz	1152	1253
WFC40500xHT	82.5	4kHz	1439	1566
WFC40600xHT	98	4kHz	1727	1879
WFC40750xHT	121	2.5kHz	2223	2223

## 2.5 Line Fuse or Circuit Breaker Sizing

The user must provide either a circuit breaker or a fused disconnect switch in accordance with the National Electric Code or Canadian Electrical Code and all local codes. The following rules should be used to select the correct size of the input line fuses or circuit breaker.

### A. Sizing/Fuse Type

The WFC<sup>HT</sup> Inverter is able to withstand a 150% overload for 60 seconds.

For maximum protection of the inverter, use the fuses listed in Table 2.5. Recommended suppliers are Bussman for 230 VAC, and for 460 VAC installations. Equivalent values from other manufacturers may be substituted.

## 2.6 Wiring Practices

### A. Applicable Codes

Care should be taken to insure that field wiring is installed in accordance with the National Electric Code (NEC) or Canadian Electrical Code (CEC) as a minimum standard. Where local codes exceed these requirements, they must be followed.

All WFC<sup>HT</sup> models are Underwriters Laboratories Inc. (UL<sup>®</sup>) and Canadian Underwriters Laboratories (cUL<sup>®</sup>) listed, and therefore comply with the requirements of NEC or CEC. Installations intended to meet UL<sup>®</sup> requirements must follow the instructions provided herein. Refer to the WFC<sup>HT</sup> technical data plate and the motor nameplate for electrical data.

Model	Fuse	Model	Fuse
WFC1001-0	KTK-10 or KTK-R-10	WFC4001-0	KTK-4 or KTK-R-4
WFC2000-7	KTK-5 or KTK-R-5	WFC4002-0	KTK-7 or KTK-R-7
WFC2001-0	KTK-7 or KTK-R-7	WFC4003-0	KTK-10 or KTK-R-10
WFC2002-0	KTK-15 or KTK-R-15	WFC4005-0	KTK-15 or KTK-R-15
WFC2003-0	KTK-25 or KTK-R-25	WFC4007-5	KTK-25 or KTK-R-25
WFC2005-0	KTK-30 or KTK-R-30	WFC4010-0	KTK-35
WFC2007-5	KTK-50	WFC4015-0	KTK-50
WFC2010-0	KTK-50	WFC4020-0	JKS-60
WFC2015-0	JKS-75	WFC4025-0	JKS-100
WFC2020-0	JKS-100	WFC4030-0	JKS-100
WFC2025-0	JKS-125	WFC4040-0	JKS-125
		WFC4050-0	JKS-175
		WFC4060-0	JKS-200
		WFC4075-0	JKS-200

TABLE 2.5

## B. Power Wiring

Power wiring is those wires which are connected during installation to the power circuit terminals, L1, L2, L3, M1, M2, and M3. Power wiring must be selected as follows:

1. Use only UL® recognized wire.
2. Wire voltage rating must be a minimum of 300 V for 230 VAC systems, and 600 V for 460 VAC systems.
3. Wire gauge to be selected based on continuous input and output currents. See Table 1.5 for current information.
4. Grounding must be in accordance with NEC and CEC.

**NOTE: Power delivered from variable frequency controls contains high frequencies which may cause interference with other equipment. Control wiring and line wiring should not be run in the same conduit or raceway with inverter-to-motor wiring.**

Where power wiring is longer than 50 feet, increase the wire size to the next larger gauge size to reduce the voltage drop in the wire.

## C. Control Wiring

Control wiring is wiring connected during installation to the control terminal strip (30 terminals). Control wiring must be selected as follows:

1. Shielded, twisted wire is recommended to prevent electrical noise interference from causing improper operation or nuisance tripping. Recommended wires are Belden types; equivalents may be substituted:

8761 (300V – 60°C – UL®-2-wire)  
 8771 (300V – 60°C – UL®-3-wire)  
 8719 (600V – 60°C – UL®-2-wire)

2. Use only UL® recognized wire.
3. Wire voltage rating must be a minimum of 300 V for 230 VAC systems, and 600 V for 460 VAC systems. This is Class 1 wire.
4. Never run the control wiring in the same conduit or raceway with power wiring. See NOTE above.
5. Connect shield to inverter COM terminal only.

## 2.7 Reducing Current Surges and Voltage Transients

Inrush currents to the coils of magnetic contactors, relays and solenoids associated with, or in close proximity to, the inverter can induce high current spikes in the power and control wiring, causing faulty inverter operation. If this condition occurs, a snubber network, consisting of a series resistor and capacitor for AC loads, or a free-wheeling or flyback diode for DC loads, should be placed across the relay coil to prevent the occurrence. The following component values should be used for 115 VAC or 230 VAC relays or solenoids.

For Main Circuit Contractors and Solenoids  
 C = 0.2 MFD, 500 VDC    R = 500Ω 5 Watts

For Auxiliary Control Circuit Relays  
 C = 0.1 MFD, 500 VDC    R = 200Ω, 2 Watts

**Connection Diagram  
for AC and DC Relay  
Coils and Solenoids**

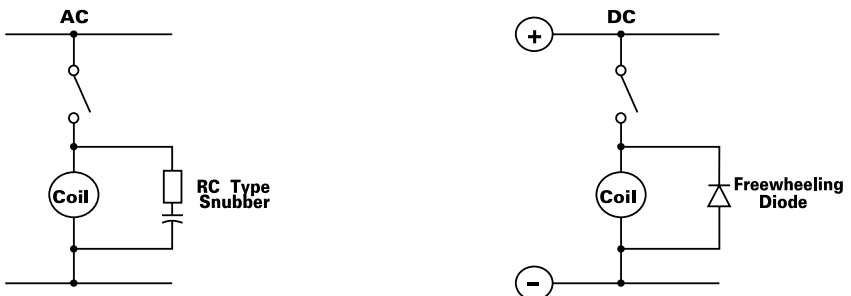

FIGURE 2.7

For magnetic contactors, relays and solenoids which are energized from a DC source, a free-wheeling diode should be used. The diode should be a high-speed, fast recovery type. Connect the diode across the coil as shown above. The diode current and voltage should be selected by the following formulae:

$$\text{Diode Current Rating (A)} = \frac{\text{Coil Capacity (VA)}}{\text{Rated Voltage of Coil (V)}}$$

$$\text{Diode Voltage Rating} = \text{Rated Voltage of Coil (V)} \times 2$$

## 2.8 Function and Use of Terminals

### A. Power Circuit Terminals

The power terminals are located on the WFC<sup>HT</sup> Power Board and are labeled **L1**, **L2**, and **L3** for incoming three phase AC line power, (**L1** and **L3** for single phase models), and **M1**, **M2**, and **M3** for the motor connections. Two other terminals **B+** and **B-** provide access to the DC bus plus and minus rails for the addition of external dynamic braking kits, or extra bus capacitors for custom applications. **GND** is located in the lower left-hand internal corner of the control casting. It is a green screw with brass cup washer and must be connected to earth ground in accordance with the NEC and CEC.

### B. Control Terminals

The control terminals are located on the bottom edge of the inverter's control board. (See Figure 2.8.) These terminals are available for use with external control devices if remote operation is desired.

**NOTE: All control terminals are isolated from earth ground. Do not exceed 50 VAC potential between any terminal and GND.**

- Control terminal impedance:
  - VIN Terminal – 100 k $\Omega$
  - CIN Terminal – 237  $\Omega$
  - All Logic Terminals – 4.5 k $\Omega$
- Logic input levels:
  - ACTIVE – 10 to 30 VDC
  - INACTIVE – 0 to 5 VDC

The input logic will accommodate either 12 or 24 VDC logic signals.

### C. Input Terminal Usage

**All WFC<sup>HT</sup> Series units are shipped from the factory programmed for Keypad only control. BEFORE USING THE INPUT TERMINALS FOR CONTROL, PARAMETERS 21-MODE AND 24-FSEL SHOULD BE READ AND UNDERSTOOD. See Section 6 – Applications for typical connections.**

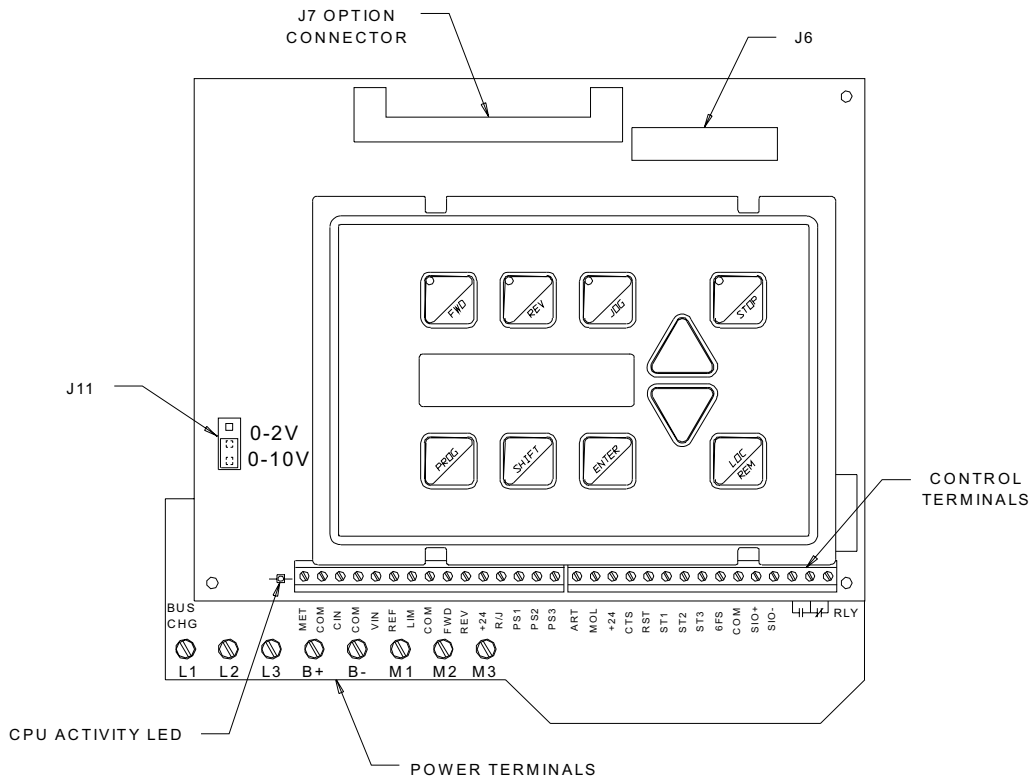

FIGURE 2.8

	DESCRIPTION OF TERMINALS			See Page	
<b>Analog Terminals</b>	<b>MET</b>	This analog output varies from 0 to full scale and is referenced to COM terminal. It may be programmed via parameter 71-METER to read output frequency, output voltage, output current, output load in percent of inverter capacity and output motor torque. The maximum full scale adjustment is calibrated by parameter 70-MCAL and can be adjusted while the inverter is running. Maximum full scale adjustment is from approximately 0-16.5 VDC. The output is rated at 5 mA. If proper wiring practices are followed, no noise should be detectable on meter output. However, in some applications noise can be observed. In this case, a 10 $\mu$ F capacitor can be inserted at the terminal strip between MET and COM to minimize this effect.		33, 48	
	<b>COM</b>	Circuit common, isolated.		–	
	<b>CIN</b>	Speed Reference input, 4 to 20 mA, 237 $\Omega$ load referenced to COM. The current input signal is calibrated by parameters 31-FMIN and 32-FMAX. FMIN sets the frequency 4 mA should generate, and FMAX sets the frequency 20 mA should produce. Operation can be inverted, 20 mA = min. frequency, and 0 mA = max. frequency. (See 24-FSEL.)		27, 48	
	<b>VIN</b>	Speed Reference input, 0 to 10 VDC or 0 to 2 VDC, selectable by jumper (J11). It will also accept pulse train inputs: 0 to 1 kHz or 0 to 10 kHz, (6-10 V peak min.) and the 6FS output from another control. Operation can be inverted, 10 VDC = min. frequency, and 0 V = max. frequency. (See 24-FSEL.)		27, 48	
	<b>REF</b>	This terminal is a +10 VDC power supply with 10 mA capacity and may be used as the Torque Limit Reference supply or the reference for VIN, in which case the drive can be programmed to shut down if the common line to the remote speed potentiometer opens. (See 24-FSEL.)		27, 48	
	<b>LIM</b>	Torque Limit input terminal. It will accept 0 to 10 VDC. 10 VDC equals 150% output torque. Defaults to +10 VDC with no input connected.		28, 48	
<b>Digital Input Terminals</b>	<b>FWD</b>	Forward Direction Selection terminal. May be connected for two-wire maintained or three-wire momentary operation.		48, 49	
	<b>REV</b>	Reverse Direction Selection terminal. May be connected for two-wire maintained or three-wire momentary operation.		48, 49	
	<b>+24</b>	Reference Voltage for Digital inputs FWD, REV, R/J (Run/Jog), PS1, PS2, PS3, MOL and ART, rated 200 mA. Overloading this terminal will result in fault F04. May be used to power relays tied to open collector outputs ST1, ST2, and ST3.		48, 49	
	<b>R/J</b>	Run/Jog Selector. When this terminal is connected to +24, momentarily connecting either FWD or REV to +24 results in a latched run mode (3-wire operation).		48, 49	
	<b>PS1 PS2 PS3</b>	Preset Speed #1 input • Preset Speed #2 input • Preset Speed #3 input Eight preset speeds are attainable; one from the main speed setter, six programmed speeds, and FMAX. Preset speeds can be programmed from 0 to 400 Hz, but FMAX sets the actual operating range. (1 is closed to +24, 0 is open.) All may be obtained from the following switching matrix:		28, 48 49	
		PS1	PS2	PS3	Effective speed reference
		0	0	0	Basic speed setpoint 24-FSEL (Default)
		1	0	0	33-F2 (5 Hz)
		0	1	0	34-F3 (20 Hz)
	1	1	0	35-F4 (40 Hz)	
	0	0	1	36-F5 (60 Hz)	
	1	0	1	37-F6 (0 Hz)	
	0	1	1	38-F7 (0 Hz)	
	1	1	1	32-FMAX (60 Hz)	
<b>ART</b>	Alternate Ramp Time Selector. Separate acceleration and deceleration ramps can be selected by connecting this terminal to +24. These ramps are programmed by parameters 41, 44 and 45. See parameter 21-MODE for more information on when this function is active.		26, 29		

TABLE 2.8



	DESCRIPTION OF TERMINALS		See Page
Digital Input Terminals	MOL	Motor Overload input terminal. Requires N.C. contact for operation, referenced to +24. Connected to +24 by a jumper wire at the factory.	5, 48, 49
	CTS	Coast to Stop. Connecting this terminal to +24 turns the drive output OFF, allowing the motor to coast to a stop. The inverter's output is cut off, not ramped to a stop. When the terminal is set to 0 V (open), the drive output is reinstated and the output will ramp to the programmed frequency. This function may be used when electro-mechanical brakes are required. This feature can also be accessed in programming by the 41-RSEL parameter to automatically coast to a stop on a stop command.	29, 49
	RST	External Fault Reset input terminal. After a fault, connecting this terminal to +24 will reset any fault.	48
Digital Output Terminals	ST1 ST2 ST3	Open collector NPN transistor output connections. Each output can be individually programmed to respond to any one of eleven conditions. (See parameters 72-ST1, 73-ST2 and 74-ST3.) Each output can sink up to 50 mA from a 24 VDC source.	34, 49
	6FS	This terminal provides a 24 VDC pulse train output which is 6X or 48X the output frequency of the inverter. Selected by parameter 88-FRO.	48
Serial Communication Port Terminals	COM	Control circuit common, electrical isolated from the AC line terminals.	42, 48
	SIO+	Positive connection for the Serial Input/Output Operation communication link. Responds to RS485 protocol. (See Section 5.)	
	SIO-	Negative connection for the Serial Input/Output Operation communication link. Responds to RS485 protocol. (See Section 5.)	
Auxiliary Relay Terminals (RLY)		Normally Open contact for the Auxiliary Relay. Will close when the relay is activated. Rating is 115 VAC at 1 Amp or 250 VAC at 0.5 Amp.	34
		Auxiliary Relay Common terminal. This relay is factory programmed to act as a Fault Relay but may be reprogrammed to any one of eleven conditions. (See parameter 75-STR.)	
		Normally Closed contact for the Auxiliary Relay. Will open when the relay is activated. Rating is 115 VAC at 1 Amp or 250 VAC at 0.5 Amp.	

TABLE 2.8 (Con't.)

## 2.9 Environmental Considerations

The WFC<sup>HT</sup> Series Inverter is rated NEMA 4 (through 50 HP), indoor use. This is a sealed unit providing a degree of protection against falling, splashing and hose-directed water.

**If your inverter will be subjected to high-pressure wash-down or atmospheric contaminants such as acid or caustic vapors, or carbon, metallic, or corrosive dust, contact TB Wood's Application Engineering Department for specific instructions.**

In order to maintain the NEMA 4 integrity of the WFC<sup>HT</sup> Inverter enclosure, some care must be exercised when the cover is installed.

With the smaller chassis configurations (WFC1000 series, WFC2000 series thru 10 HP and WFC4000 series thru 20 HP), the following cover installation procedure shall be employed:

1. Snug each of the four (4) cover screws into place.
2. Sequentially tighten each screw until the gasket is compressed evenly. Tighten first one corner then the opposing corner to minimize the chance of pinching the gasket.
3. **Tighten these screws to 18-inch pounds of torque.**

With the larger chassis configurations, the cover should be installed according to the following procedure:

1. Swing the hinged door closed making sure that the gasket is not pinched.
2. Sequentially tighten each screw until the gasket begins to compress. Alternate sides of the enclosure when tightening to assure even compression.
- 3a. If drive serial number is 98279999 or lower, **tighten these screws to 10-inch pounds of torque**
- 3b. If drive serial number is 98280000 or higher, **tighten these screws to 18-inch pounds of torque.**

If the conduit entries are not used, utilize the hole plugs (supplied with the NEMA 4 models and the WCK01 thru WCK04 Chassis Mounting Kits) to close the unused holes. This will assure the enclosure's environmental integrity.

## SECTION 3

### GETTING STARTED

#### 3.1 General Information

- All WFC<sup>HT</sup> Series Inverters come with a digital keypad as standard equipment.
- Your WFC<sup>HT</sup> AC Inverter is preprogrammed to run a standard AC induction motor; in many cases no additional programming is required.
- WFC<sup>HT</sup>'s advanced digital keypad controls all operations of the inverter. The ten input keys allow “Press and Run” operation of the motor and straightforward programming of the parameters. To simplify the programming further, the parameters are separated into programming levels:

LEVEL 1 Easily accessed by pressing the PROG key at anytime. Limits access to the most commonly used parameters for operator convenience.

LEVEL 2 This is used when the more advanced features of WFC<sup>HT</sup> are needed. It is accessed by pressing the SHIFT and PROG keys simultaneously. All parameters can be either viewed or programmed except those associated with the SIO Serial Communications Link.

LEVEL 3 This level is automatically added to Level 2 when the SIO Serial Input/Output link is selected.

#### 3.2 Digital Keypad

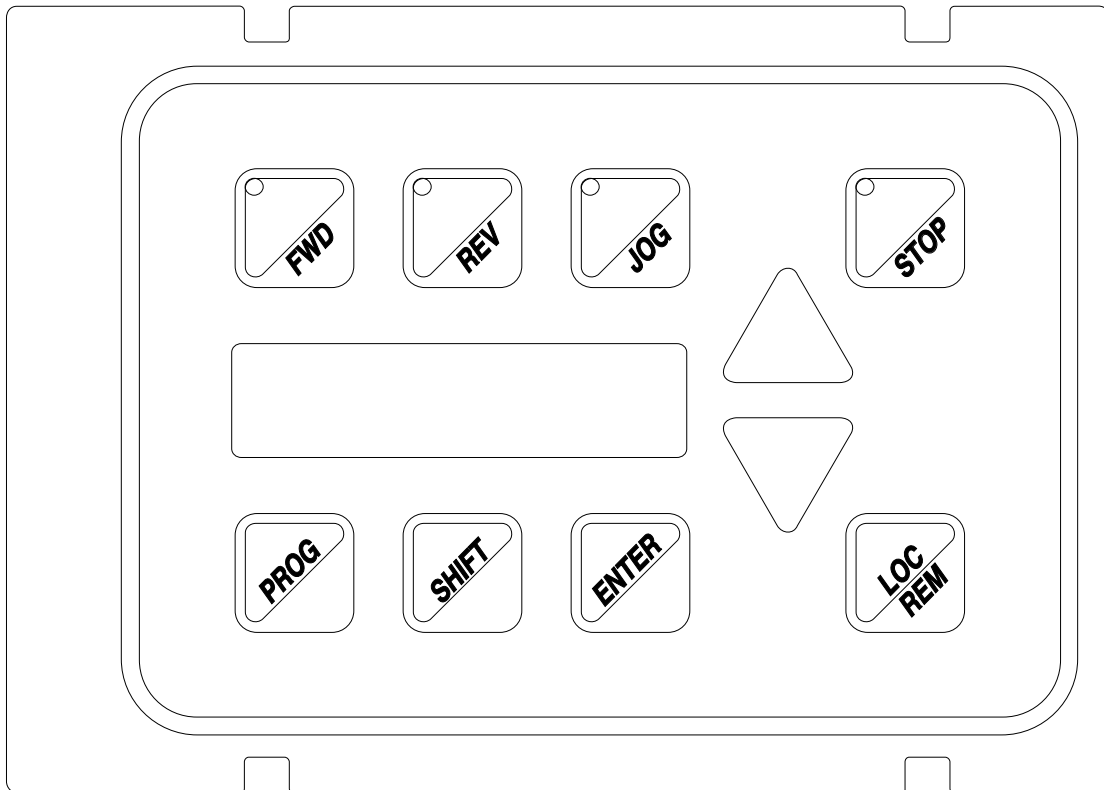



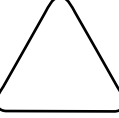
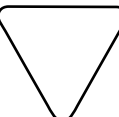







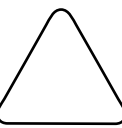
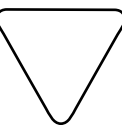

FIGURE 3.2

The digital keypad controls the WFC<sup>HT</sup> in both the operating and programming modes. A detailed description of all the keys and displays follows:





### 3.3 Operation Mode (STOP and RUN modes)

KEY	FUNCTION
	Initiates forward run when pressed momentarily. If the drive is running in reverse when <b>FWD</b> is pressed, it will decelerate to zero speed, change direction and accelerate to the set speed.
	Initiates reverse run when pressed momentarily. If the drive is running in forward when <b>REV</b> is pressed, it will decelerate to zero speed, change direction and accelerate to the set speed. May be disabled by the setting of 21-MODE (factory setting). <b>Note: If both keys are pressed and held at the same time, the drive follows the first key pressed.</b>
	Press to enter the JOG mode when stopped. When in the JOG mode, the drive will ramp in the forward direction to a programmable JOG speed (33-F2) while the <b>FWD</b> key is held. The drive will ramp to a stop when the <b>FWD</b> key is released. Pressing the <b>REV</b> key causes a similar operation. The ramp will be at a rate set for normal acceleration and deceleration. To leave the JOG mode, press <b>STOP</b> or the <b>JOG</b> key a second time.
	Causes a Ramp-To-Stop when pressed. This function can be programmed to cause a Coast-To-Stop when pressed (41-RSEL). If the drive has stopped due to a Fault condition, pressing the <b>STOP</b> key will reset the fault. Also functions as an emergency stop when the drive is remotely controlled.
	In the Stop mode, pressing this key increases the desired running speed of the drive. That is, the speed to which the drive will accelerate when a Run is initiated. In the Run mode, pressing this key dynamically adjusts the running speed of the drive. Setting resolution is 0.01 Hz. If the key is pressed and held for five (5) seconds, the setting frequency will scroll automatically at an increased rate. Also see <b>SHIFT</b> description below.
	In the Stop mode, pressing this key decreases the desired running speed of the drive. That is, the speed to which the drive will accelerate when a Run is initiated. In the Run mode, pressing this key dynamically adjusts the running speed of the drive. Setting resolution is 0.01 Hz. If the key is pressed and held for five (5) seconds, the setting frequency will scroll automatically at an increased rate. Also see <b>SHIFT</b> description below.
	In the Stop or Run modes, pressing this key will “Lock-in” the frequency selected by the <b>UP</b> and <b>DOWN</b> arrow keys so that if power is removed and reapplied, that frequency will be the initial default speed setting. The display will show <b>**STORED**</b> for 1 second when the command is completed.
	Shifts drive control between the <b>LOC</b> al and <b>REM</b> ote control modes as selected by the 21-MODE parameter. Can be programmed to shift: <ol style="list-style-type: none"> <li>1) The Run/Stop command (either FWD or REV) <i>or</i></li> <li>2) The speed reference signal <i>or</i></li> <li>3) Both <i>or</i></li> <li>4) Disabled (factory setting).</li> </ol> <p>Will operate either in the Stop mode or while the drive is running. If power is removed and reapplied, the memory will retain the last selected function.</p>
	In the Run mode, pressing this key will access the parameters at Level 1 for viewing only. Pressing the <b>SHIFT</b> and <b>PROG</b> keys simultaneously will access Level 2 for viewing only. The <b>UP</b> and <b>DOWN</b> arrow keys will work as described in the Programming section of this document. Operation of the motor will not be affected while viewing the information in these parameters, and parameter changes cannot be made.
	Pressing <b>SHIFT</b> momentarily while holding either the <b>UP</b> or <b>DOWN</b> arrows will initiate the fast scroll without waiting for the five second delay. Pressing it a second time will start the fastest scroll rate.

### 3.4 Program Mode

KEY	FUNCTION
	When in the <b>STOP</b> mode, pressing this key will enter the PROGRAM mode at Level 1. Pressing this key at any time while in the PROGRAM mode will return the unit to the OPERATION mode. Pressing the <b>SHIFT</b> and <b>PROG</b> keys simultaneously will enter Level 2. If an Access Code has been entered, re-entry is required to change program data.
	In the <b>PROGRAM</b> mode, pressing this key will move forward through the successive Parameter Addresses. When changing Data in a Parameter, this key will increment the data value. The <b>ENTER</b> key must be pressed to store the new value.
	In the <b>PROGRAM</b> mode, pressing this key will move backward through the successive Parameter Addresses. When changing Data in a Parameter, this key will decrement the data value. The <b>ENTER</b> key must be pressed to store the new value.
	<b>NOTE:</b> At all parameters except 85-UNITS, momentarily pressing both the <b>UP</b> -arrow and <b>DOWN</b> -arrow keys simultaneously will return the parameter setting to factory defaults.
	Pressing this key while a Parameter is displayed will allow that Parameter to have its data changed by use of the <b>UP</b> and <b>DOWN</b> arrow keys.
	Pressing this key after data has been changed in a Parameter will store that information in nonvolatile memory.

### 3.5 Status (LED) Indicators

LED	INDICATION/LOCATION
	The red Stop LED, located in the <b>STOP</b> key, illuminates whenever a stop command has been given. If the inverter has stopped due to a fault, this LED will flash to call attention to the digital display.
	The green Forward LED, located in the <b>FWD</b> key, illuminates whenever a forward command has been given. When both the Forward and Reverse LED's are on, the DC braking function is active.
	The green Reverse LED, located in the <b>REV</b> key, illuminates whenever a reverse command has been given. When both the Forward and Reverse LED's are on, the DC braking function is active.
	The green Jog LED, located in the <b>JOG</b> key, illuminates to signify the inverter is in the JOG mode of operation.

### 3.6 Description of Displays

The WFC<sup>HT</sup> Series Inverter has been designed to provide the greatest level of information possible to the operator through an easily readable 2x16 character Back Lit LCD alpha-numeric display, including data on drive and motor status, fault information and parameter values. This section will give a brief description of the various display formats that may be seen during startup, operation and programming.

The restart display is present whenever power is applied to the inverter or a fault condition is reset. It will be displayed for about one second during which time the computer is checking various functions within the inverter.

During normal operation, the operating display will provide important information about the inverter and load.

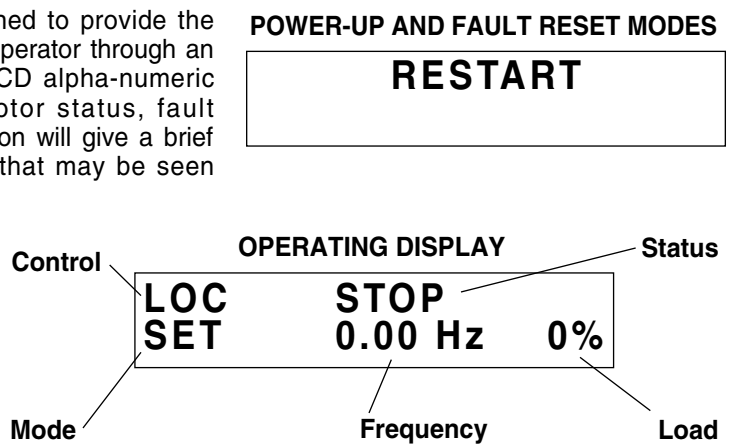

#### CONTROL

The first three characters of the top line denote the source of control for the inverter:

<b>LOC</b>	Local control via the Keypad
<b>REM</b>	Remote control from the terminal strip
<b>SIO</b>	Remote control via the RS485 Serial SIO Link
<b>SEQx</b>	Control via the Program Sequencer
<b>ADJ</b>	Auto-tune mode for Parameter 5B-IMAG

#### STATUS

Twelve characters are dedicated to the current status of the inverter output. This includes normal operating conditions and warning messages:

<b>STOP</b>	The inverter is in the STOP mode.
<b>ACCELERATE</b>	The motor is increasing in speed.
<b>DECELERATE</b>	The motor is decreasing in speed.
<b>AT SPEED</b>	Motor speed is at the desired set point.
<b>ZERO SPEED</b>	The inverter is in the RUN mode, but the motor is not turning.
<b>JOG</b>	Motor runs only while the FWD or REV keys are pressed. (Displayed only while JOGGING).
<b>TORQ LIMIT</b>	The output torque of the inverter has reached its programmed limit level.
<b>DYN BRAKE</b>	The Dynamic Braking circuit is helping to decelerate the motor and load.
<b>HI TEMP</b>	The temperature of the drive is near the maximum limit point.
<b>HI CURRENT</b>	The output current is near the overcurrent cutoff point.
<b>HI VOLTAGE</b>	The voltage on the DC bus is near the high voltage cutoff point.
<b>LO VOLTAGE</b>	The voltage on the DC bus is near the low voltage cutoff point.
<b>SPD SEARCH</b>	Autostart has been programmed to 82-START, and the inverter is attempting to synchronize its output with the motor speed.
<b>IDLE#xx</b>	SIO mode of operation only. The drive is programmed to SIO address (92-SIOA) = xx. It is awaiting either a program or run command.
<b>LS LOCKOUT</b>	Line Start Lockout. A run command was detected when power was applied.

#### MODE

The first three characters on the second line denote the present operating mode of the inverter:

<b>FWD</b>	A Forward run command has been given.
<b>REV</b>	A Reverse run command has been given.
<b>SET</b>	The inverter is waiting to have, or is having, the running frequency set.

#### FREQUENCY

The standard display shows the inverter operating frequency in Hertz. This can be custom tailored to any engineering or machine units by the setting of parameters **84-DISP** and **85-UNITS**.

#### LOAD

The last four characters in line 2 display the percentage of maximum continuous inverter output current that is being delivered. If a custom display is programmed on this line, this information is not displayed but is still viewable at parameter **15-LOAD**.

When the programming mode is accessed by pressing the PROG key for LEVEL 1 or SHIFT and PROG keys for LEVEL 2 or 3, the display to the right will appear for one second.

**RIGHTS**

This section explains the operator’s access rights after the program mode has been entered:

- PROGRAM** This indicates that while in the programming mode parameter data can be changed.
- VIEW** If the inverter is in the run mode (forward or reverse) when the PROG key was pressed, parameters may be viewed but not changed.

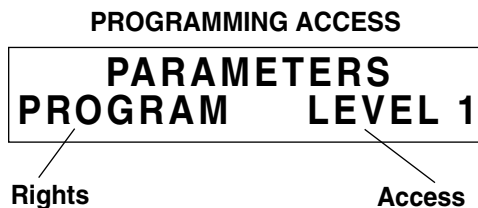

**ACCESS**

This denotes the access level that is being entered. It may show Level 1 or Level 2 (Section 4) or Level 3 (Section 5).

Once the program mode has been accessed, the display shown to the right will provide information on each parameter:

**DESCRIPTION**

The top line will give a full 16 character description of the parameter that is being accessed.

**RIGHTS**

The first four characters of the second line will indicate if the particular parameter can be changed (**PROG**) or only examined (**VIEW**). If an attempt is made to change data while in the **VIEW** mode, the message **\*\*NO ACCESS\*\*** will be displayed for one second.

**PARAMETER**

This is the actual parameter number being displayed. When data is being changed, this number will blink on and off. See inside the front cover for a listing of all Level 1 and Level 2 parameters.

**DATA**

Up to eight characters are used to display the information stored in the parameter. Some parameters have a unit designator such as:

- s** – Seconds
- h** – Hours
- C** – Degrees centigrade
- Hz** – Hertz
- %** – Percent
- A** – Amperes

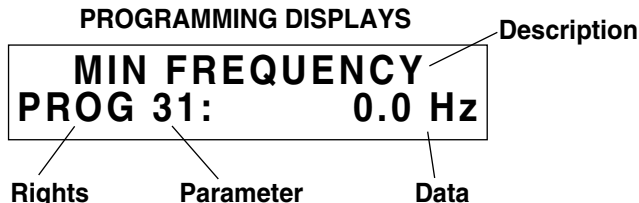

When the inverter stops due to a fault trip, a unique error message will be displayed along with a flashing **STOP LED** indicator. Two “pages” of information are available concerning the actual fault and drive status. Page one is shown at right.

**CODE**

The top line signifies that a fault has occurred and displays one of 19 fault codes. See Section 7 – Troubleshooting for a complete list of all codes and explanations of each.

**NEXT PAGE**

The “^” symbol indicates that pressing the Up Arrow will shift the display to Page 2.

**DESCRIPTION**

The second line provides a full 16 character description of the cause of the fault.

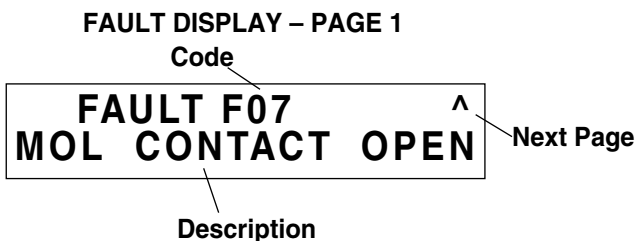

Page 2 of the fault display will show the operating conditions of the inverter at the time of the fault. All other operating parameters are “frozen” until the drive is reset.



### 3.7 OPERATING TIPS

#### Parameter Access

- When the **PROG** (or **SHIFT-PROG**) key is pressed after application of power, **21-MODE** will always be the first parameter displayed.
- If a different parameter is accessed and the Program mode is exited, that parameter will be the point of entry the next time the programming mode is accessed.
- The WFC<sup>HT</sup> will remember different “last parameters” for Levels 1, 2, and 3.
- If no key is pressed for 10 minutes while in the programming mode, the WFC<sup>HT</sup> will automatically revert back to the operating mode.

#### Display Scroll Rate

- Three scroll rates are used to speed entry of information into the WFC<sup>HT</sup>.
- If either the **UP** or **DOWN** arrow is pressed and held for five seconds, the rate of change of the display will increase.
- If the **SHIFT** key is momentarily pressed while holding one of the arrow keys, the five second delay will be bypassed.
- If the **SHIFT** key is pressed a second time while holding an arrow key, the display will scroll at the fastest rate. This is useful for entering very large numbers as in parameter **84-DISP**.

#### Restoring Factory Settings

- Whenever a parameter’s data is being changed (noted by the Parameter number blinking), the original factory setting for that parameter can be restored by pressing both the **UP** and **DOWN** arrows simultaneously and pressing the **ENTER** key.
- To restore ALL parameters to their factory settings, see parameter **81-PRGNO**.

#### Help

- For Application Assistance, call TB Wood’s Incorporated Electrical Engineering at 800-789-6637 to talk to an Electrical Application Engineer.

### 3.8 Quick-Start – Running the Motor

This section is for operators who would like to get up and running quickly and with a minimum amount of research through the manual. Be sure to read sections 3.1 through 3.7 before proceeding. In many cases your WFC<sup>HT</sup> will perform perfectly without making any changes to the factory settings.

- A. Perform all procedures for installation as specified in Section 2 – Installation Instructions. **REVERIFY THAT THE PROPER VOLTAGE IS AVAILABLE FOR THE INVERTER BEFORE APPLYING POWER. FAILURE TO DO THIS CAN RESULT IN EQUIPMENT FAILURE AND PERSONAL INJURY!**

- B. Apply AC power to the input terminals. For about one second, all the LED indicators will illuminate and the display will show:

<b>RESTART</b>
----------------

After one second, only the STOP LED will stay on and the display will change to:

<b>LOC SET</b>	<b>STOP 0.00 Hz</b>	<b>0%</b>
--------------------	-------------------------	-----------

- C. The factory settings for the WFC<sup>HT</sup> Series are for keypad only operation in the forward direction. This means that the REV key and the LOC/REM key are disabled.

Press the FWD key; the display will change to:

<b>LOC SET</b>	<b>ZERO SPEED 0.00 Hz</b>	<b>0%</b>
--------------------	-------------------------------	-----------

- D. Press the UP arrow to increase the desired running frequency. When the motor starts to turn, note the direction of rotation. If the motor is turning in the wrong direction, **STOP THE DRIVE, REMOVE AC POWER AND WAIT FOR THE BUS CHARGE INDICATOR TO GO OUT**. After the Charge indicator is extinguished, reverse any two of the motor leads at M1, M2 or M3.
- E. The length of time that the UP arrow is depressed determines the scroll rate of the display. After it is held for five seconds, the rate of change will increase. The five second time can be circumvented by momentarily pressing the SHIFT key while holding the UP (or DOWN) arrow.
- F. The inverter is preset to run a “typical” NEMA B induction motor to a maximum speed of 60.00 Hz with both Acceleration and Deceleration times set to 3.0 seconds. The Jog frequency is set for 5.0 Hz.
- G. Use the Arrow keys to set the proper running speed of the motor and the FWD and STOP keys to control its operation.

### 3.9 High Torque Set Up Procedure

The following procedure allows the WFC<sup>HT</sup> series AC inverter to be set up for low speed, high torque operation.

1. Program Parameter 51-VSEL to Data Code 6 (see page 30).
2. Program Parameter 65-SLIP per the formula on page 32.
3. Run the drive at 15 Hz setpoint and minimal loading (free shaft operation if possible). Enter Level 2 programming and scroll to parameter 5B-IMAG. 'ADJ' should appear in the lower left corner of display. Press the 'ENTER' key on keypad to have the drive Auto-tune the 5B-IMAG value. The drive will measure the magnetizing currents and place a value into parameter 5B-IMAG. Although not required, repeating the process to verify consistent results is recommended.

Check the system for performance. For most applications, the above procedure is sufficient for ideal drive-motor performance. For additional fine-tune adjustments, see the following steps.

1. Run the motor in the 2-6 Hz range. If the drive appears to draw excessive currents at low speeds with no load, decrease the setting of 5B-IMAG. Too much 5B-IMAG can result in unstable motor operation.
2. Run the motor in the 2-6 Hz range under full load conditions. If the drive draws greater than motor nameplate current, reduce the value of 52-BOOST. If it appears the motor is not developing sufficient torque, increase the value to 52-BOOST. Note: For proper performance at frequencies below 6 Hz, inverter duty motors are recommended. 52-BOOST is set at a value predetermined for premium efficiency motors. When using inverter and vector duty motors, the value of 52-BOOST may need to be adjusted.

If additional problems arise, contact TB Wood's Electronics Applications Engineering at 888-829-6637 for assistance.

# SECTION 4

## PARAMETER DESCRIPTIONS AND PROGRAMMING

- Level 1 - accesses only basic operator parameters.
- Level 2 - accesses all parameters in Level 1 and Level 2
- Level 3 - accesses all parameters in Level 1, Level 2 and Level 3. For more information consult Section 5 and Form 997 - SIO SERIAL LINK PROTOCOL.

### 4.1 Programming

To change the default programming for a given parameter:

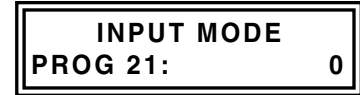

- A. Press the **STOP** key, if the inverter is running. Some parameters (see the individual parameter description) can be changed while the inverter is operating.
- B. To enter Level 1 programming, press the **PROG** key. To enter Level 2, hold the **SHIFT** key and press the **PROG** key.
- C. Use the **UP/DOWN** arrow keys to select the program parameter for change.
- D. Press the **SHIFT** key. The program number will blink indicating that the data value may be changed.
- E. Use the **UP/DOWN** arrow keys to select the new data code.
- F. Press the **ENTER** key. The display will indicate **\*\*STORED\*\*** for one second, then revert to the normal parameter display.
- G. Press the **PROG** key to exit the programming mode or the **UP/DOWN** arrow keys to select a new parameter for change.

### 4.2 Parameter Descriptions

This section provides a functional description of all WFC<sup>HT</sup> Series programming parameters at Level 1 and Level 2. Those with a level indication including an asterisk (\*) cannot be programmed, but can be viewed while the drive is functioning.

Parameter	Units	Level
<b>01-MODEL</b> - Inverter Model Number		L1*
This display is a code that conveys the input voltage rating and horsepower rating of the control. For example, a code of 10010 would equate to an WFC <sup>HT</sup> with a 115 VAC input and 1.0 HP rating. A code of 20020 would equate to a 230 VAC input and 2.0 HP rating, 40075 would indicate 460 VAC and 7.5 HP ratings.		
<b>02-RVLVL</b> - Software Revision		L2*
This display indicates the software revision installed in your inverter.		
<b>03-IRAT</b> - Inverter Rated Current		L2*
This display indicates the 100% rating of output current for the inverter. It is used by the inverter as the basis for all current measurements and output indications. Your WFC <sup>HT</sup> inverter can provide 110% of this rating continuously without damage or tripping.		
<b>05-SERNO</b> - Manufacturing Serial Number		L2*
This is the unique serial number assigned to the inverter.		
<b>06-REP</b> - Repair Date Code		L2*
If the control has been repaired in a Wood's facility, a specific code will be installed in this location.		
<b>07-FLT3</b> - Last Fault		L1*
<b>08-FLT2</b> - Second Fault		L2*
<b>09-FLT1</b> - First Fault		L2*
These displays indicate a code that represents both the cause of the last three (3) inverter faults and the elapsed time (in 0.1 Hr. increments) between the fault occurrence and the resetting of it. Parameter 07-FLT3 contains the most recent occurrence, 08-FLT2, the one prior to that, and 09-FLT1, the first fault on record. The elapsed time since the last restart (power up or fault reset) is the last digit and indicates up to 0.9 Hr. The remainder of the code represents the reason for the trip. Consult Section 7, Troubleshooting, for a list of fault codes and their potential causes.		
<b>12-FOUT</b> - Inverter Output Frequency	Hz	L1*
This display indicates the output frequency at which the inverter is operating.		
<b>13-VOUT</b> - Motor Output Voltage	%	L1*
This display indicates the percent of input voltage that is being delivered by the inverter to the motor. It is useful when operating motors with non-standard Volts/Hertz (V/Hz) ratios by means of 53-FKNEE and 32-FMAX.		

Parameter	Units	Level
<b>14-IOUT</b> - Motor Output Current This display indicates computed output current in amperes. The accuracy of this display is $\pm 10\%$ of inverter rating (03-IRAT).	A	L1*
<b>15-LOAD</b> - Drive Load This display indicates the real part of the motor current by multiplying the computed output current by motor power factor and comparing it to the inverter's capacity. This indication is positive in the motoring mode, negative in the regenerative mode of operation. The accuracy is $\pm 10\%$ of full scale.	%	L1*
<b>16-TORQ</b> - Load Torque This display shows the torque reduction experienced when operating in the constant power or field weakened condition, when operating above 53-FKNEE. The accuracy is $\pm 10\%$ of full scale.	%	L1*
<b>17-TEMP</b> - Inverter Temperature This display indicates the inverter's operating temperature in $^{\circ}\text{C}$ . The accuracy is $\pm 2^{\circ}\text{C}$ .	C	L1*
<b>18-TIME1</b> - Total Run Time This display is an indication of the total time the inverter is in the run mode of operation. It has a range of 0-65000 hr. and is not resettable. <b>Note: Frequent line starting operation of the inverter may result in the recording of erroneous times in this parameter.</b>	h	L2*
<b>19-TIME2</b> - Total Operating Time This display indicates the total time that power has been applied to the inverter, up to 65,000 hrs. It does not reset when power is removed and re-applied.	h	L2*
<b>1A-FOUT2</b> - Motor Stator Frequency In order for the inverter to provide the motor performance desired in many applications, it is necessary for the inverter to make changes to the motor frequency independent of the speed setpoint. For instance, when slip compensation is active, the motor frequency is increased when the motor's load increases. Parameter 1A allows actual motor frequency to be monitored during operation.	Hz	L2
<b>1B-FLUX</b> - Magnetizing Current This display indicates the amount of magnetizing current that is present to the motor. The displayed percentage is a calculated factor based on a pre-determined motor model. When using Volts/Hertz mode, the percentage is based on bus current measurements and torque boost settings. In Vector mode, the percentage is the inverter's regulated magnetizing current levels. Parameter 1B can be monitored while the inverter is in operation.	%	L2
<b>21-MODE</b> - Input Mode 21-MODE defines the operating functions that are active from the Keypad, the Terminal Strip, and the SIO Serial Link in both the LOCal and REMote operating modes. Also the mode transfer mechanism is defined by your selection at this parameter. Proper setting of this parameter is the first step in customizing the inverter to your application. The following table defines all the combinations available. Other selections for 21-MODE are discussed in Section 5 and in option manuals where their use is fully documented.		L1

DATA CODE		LOCAl (1)		REMote		LOC/REM Transfer via:	See Note
FWD only (2)	FWD/REV (2)	Speed (3)	Start/Stop	Speed (3)	Start/Stop		
<b>Keypad Control Only</b>							
0/20	10/30	Keypad		Disabled		N/A	
<b>Terminal Strip Control Only</b>							
4/24	14/34	Disabled		Terminals		N/A	4
<b>Combination Keypad / Terminal Strip Control</b>							
1	11	Keypad		Terminals	Keypad	LOC/REM key	4,5
2	12	Keypad		Keypad	Terminals	LOC/REM key	4
3	13	Keypad		Terminals		LOC/REM key	4
21	31	Keypad		Terminals	Keypad	PS3	4,5
22	32	Keypad		Keypad	Terminals	PS3	4
23	33	Keypad		Terminals		PS3	4

**Notes:**

- Under LOCal operation, when control is specified as keypad, the active torque limit reference is the preset values at parameters 61 thru 64 as if parameter 27-TLSEL were set to a code "3". In all other cases, the drive obeys the setting of parameter 27 directly.
- Enables or disables the REV key on the keypad.
- When "Terminals" specified as a speed reference, the programming of parameter 24-FSEL actually controls the active speed reference.
- In REM operation, terminals PS1, PS2, PS3 and ART are active. All will (except PS3 in modes greater than 20) perform their previously defined function (see Section 2.8).
- Entering the JOG mode from the keypad will override any active presets.

If any questions arise, please don't hesitate to contact an Electrical Applications Engineer at the factory for clarification before proceeding. See Section 6 for terminal strip connection details.

**Parameter** **Units** **Level**

**24-FSEL - Speed Reference Selector** L2

**Note: Reference 21-MODE and parameter 32-FMAX thru 38-F7 for a thorough understanding of this parameter setting.**

This parameter is used to define the frequency command signal source when operating from other than the inverter's keypad. That generally means the definition of signal types applied to either the VIN or CIN terminals. This parameter can also be used to re-define terminal strip speed control (referenced in 21-MODE) as keypad operation.

**The proper usage of this parameter is dependent on the selection made at 21-MODE. Typically, no changes are necessary at this parameter.**

DATA CODE	REFERENCE	DESCRIPTION	See Note
0	VIN/CIN	Terminal input, speed pot or external 0-2, 0-10 VDC or 4-20 mA	1
1	-VIN/CIN	Terminal input, inverse speed control	
2	VIN	Same as Code 0, but external speed pot current monitored. If any of the three connections are broken, the drive will stop. Not for use with any externally supplied voltage or current references.	
3	VIN	Terminal input, follows the 6FS (6X) output of another WFC series inverter.	1, 3
4	FPT1	Pulse train input at VIN, 0-1 kHz (6-10 VDC peak minimum)	1
5	FPT2	Pulse train input at VIN, 0-10 kHz (6-10 VDC peak minimum)	
6	FKPAD	Keypad Speed Reference	
7	FEXT2	External speed reference 2 programmed via 26-FEXT2 (default = 0 Hz)	
8	FEXT1	External speed reference 1 programmed via 25-FEXT1 (default = 0 Hz)	
9	F2	Programmable via 33-F2 (default = 5 Hz)	
10	F3	Programmable via 34-F3 (default = 20 Hz)	
11	F4	Programmable via 35-F4 (default = 40 Hz)	
12	F5	Programmable via 36-F5 (default = 60 Hz)	
13	F6	Programmable via 37-F6 (default = 0 Hz)	
14	F7	Programmable via 38-F7 (default = 0 Hz)	
15	FMAX	Programmable via 32-FMAX (default = 60 Hz)	
19	VIN	Terminal input, follows the 6FS (48X) output of another WFC series inverter.	

**Notes:**

1. Data codes 0 thru 5 define the type and response characteristic of input speed signal connected to the terminal strip of the inverter.
2. If speed control is programmed from the keypad at parameter 21-MODE, the selection at parameter 24 is ignored.
3. Frequency of input signal determined by parameter 88-FRO. If parameter 24-FSEL is set data code 19, adjust the J2 jumper (see page 15, figure 2.8) to the 0-2V position for better resolution. The table that follows notes the maximum operating frequency when using this data code and parameter 83-PWM. Consult the factory with any questions.

The maximum running frequency available when using data code 19 (48x pulse train from another WFC<sup>HT</sup> series inverter) is limited by the operating carrier frequency. When selecting the carrier frequency at parameter 83-PWM and parameter 24-FSEL is set to data code 19, the maximum operating frequency will be limited by the following values.

For all models except the WFC4075-0:

For the WFC4075-0 only:

83-PWM data code 1 (3kHz) ----	62 Hz max.	83-PWM data code 1 (2.3 kHz) ----	48 Hz max.
83-PWM data code 2 (4kHz) ----	83 Hz max.	83-PWM data code 2 (2.5 kHz) ----	52 Hz max.
83-PWM data code 3 (6kHz) ----	125 Hz max.	83-PWM data code 3 (4.6 kHz) ----	95 Hz max.
83-PWM data code 4 (8kHz) ----	166 Hz max.	83-PWM data code 4 (5 kHz) ----	104 Hz max.
83-PWM data code 5 (12kHz) ----	250 Hz max.	83-PWM data code 5 (9.2 kHz) ----	191 Hz max.
83-PWM data code 6 (16kHz) ----	332 Hz max.	83-PWM data code 6 (10 kHz) ----	208 Hz max.

**Parameter** **Units** **Level**

**27-TLSEL** - Torque Limit Reference Selector

L2

TLSEL selects one of seven combinations of six torque limit setpoints to be effective during driving and regenerative operation. Torque limit may be different for forward and reverse operation. Parameter 21-MODE can override this selection when it dictates that the drive operates under keypad control.

**The proper usage of this parameter is dependent on the selection made at 21-MODE. Typically no changes are necessary at this parameter.**

DATA CODE	REVERSE		FORWARD	
	REGENERATIVE	MOTORING	REGENERATIVE	MOTORING
0	LIMit input	LIMit input	LIMit input	LIMit input
1	64-RTLr	LIMit input	63-RTLf	LIMit input
2	64-RTLr	62-LTLr	63-RTLf	LIMit input
3	64-RTLr	62-LTLr	63-RTLf	61-LTLf
4	28-TLEXT	28-TLEXT	28-TLEXT	28-TLEXT
5	64-RTLr	28-TLEXT	63-RTLf	28-TLEXT
6	64-RTLr	62-LTLr	63-RTLf	28-TLEXT

See Section 5 for more information on parameter 28-TLEXT.

**31-FMIN** - Minimum Frequency

Hz

L1

31-FMIN defines the minimum frequency that the inverter will deliver to the motor in the run mode. It is adjustable in 0.01 Hz increments from 0 to 400 Hz. The factory setting is 0 Hz.

**32-FMAX** - Maximum Frequency

Hz

L1

32-FMAX defines the maximum frequency that the inverter will deliver to the motor in the run mode. It is adjustable in 0.01 Hz increments from 20 to 400 Hz. The factory setting is 60 Hz.

**FOR OPERATION ABOVE 60 Hz, ENSURE THAT THE MOTOR IS CAPABLE OF EXTENDED SPEED OPERATION. SEE THE INSTRUCTIONS FOR PARAMETER 53-FKNEE FOR MORE INFORMATION.**

**PARAMETER 83-PWM WILL ADDITIONALLY INFLUENCE THE ACTUAL MAXIMUM FREQUENCY CAPABILITY OF THE DRIVE.**

**33-F2** - Preset Frequency #2 (Jog)

Hz

L1

**34-F3** - Preset Frequency #3

Hz

L2

**35-F4** - Preset Frequency #4

Hz

L2

**36-F5** - Preset Frequency #5

Hz

L2

**37-F6** - Preset Frequency #6

Hz

L2

**38-F7** - Preset Frequency #7

Hz

L2

Parameter 33-F2 is preset speed #2 and is used to set the JOG speed reference when in the keypad operating mode. All preset values are programmed and operate in conjunction with 24-FSEL. Each is adjustable in 0.01 Hz increments from 0 to 400 Hz. Parameters 36, 37, and 38 are adjustable “on-the-fly.”

**Refer to Table 2.8 and Section 6 for proper selection of preset frequencies.**

Parameter	Units	Level
<b>39-FTL</b> - Minimum Frequency in Torque Limit	Hz	L2
When the drive's output current exceeds the limits defined by 27-TLSEL, the motor will be decelerated at a rate determined by 46-DECTL to the frequency programmed at this parameter. If this parameter is set to a value greater than parameter 32-FMAX, TORQUE LIMITING WILL BE DISABLED.		
<b>41-RSEL</b> - Ramp Selector		L2
This parameter defines the acceleration and deceleration characteristics of the drive. The following table outlines the possibilities:		

DATA CODE	DESCRIPTION
0	42-ACC1 and 43-DEC1 control drive acceleration and deceleration for both forward and reverse operation. 44-ACC2 and 45-DEC2 are selected by input terminal ART. To use ART, 21-MODE must be set for terminal strip start/stop control.
1	First set of ramps in the forward direction, second set of ramps in the reverse direction. Terminal ART is inactive.
2	Dual slope linear ramp. Primary set of ramps control acceleration / deceleration when 12-FOUT less than the value programmed at 37-F6. Secondary set of ramps control when 12-FOUT greater than 37-F6. Terminal ART is inactive.
3	"S" curve acceleration and deceleration. Terminal ART is inactive.
4	Performance same as code "0" except Coast-to-stop when STOP is commanded.
5	Performance same as code "1" except Coast-to-stop when STOP is commanded.
6	Performance same as code "2" except Coast-to-stop when STOP is commanded.
7	Performance same as code "3" except Coast-to-stop when STOP is commanded.

**42-ACC1** - Acceleration Ramp #1 s L1  
Parameter 42-ACC1 defines the primary inverter response to an increase in speed command. It is adjustable in 0.01 second increments from 0.1 to 600 sec. from zero to maximum frequency. The factory setting is three (3) seconds.

**43-DEC1** - Deceleration Ramp #1 s L1  
Parameter 43-DEC1 defines the primary inverter response to a decrease in speed command. It is adjustable in 0.01 second increments from 0.1 to 600 sec. from maximum to zero frequency. The factory setting is three (3) seconds.

**44-ACC2** - Acceleration Ramp #2 s L2  
Parameter 44-ACC2 defines the secondary inverter response to an increase in speed command. It is adjustable in 0.01 second increments from 0.1 to 600 sec. from zero to maximum frequency. The factory setting is one (1) second.

**45-DEC2** - Deceleration Ramp #2 s L2  
Parameter 45-DEC2 defines the secondary inverter response to a decrease in speed command. It is adjustable in 0.01 second increments from 0.1 to 600 sec. from maximum to zero frequency. The factory setting is one (1) second.

**46-DECTL** - Torque Limit Response Time s L2  
When the drive senses that the torque limit threshold has been exceeded, it takes immediate action. If operating in the motoring mode, it begins to decelerate toward the value of 39-FTL. If operating in the regenerative mode, it begins to accelerate toward the rotational speed to which it is being driven. In either case, 46-DECTL governs the drive's response time.

**47-DCBRK** - DC Brake Time s L2  
In the keypad or terminal input mode, after issuing a STOP command, the inverter ramps down to zero speed and provides a holding DC current in the motor windings for the period set by 47-DCBRK. This function is not available with zero (0) seconds set at 47-DCBRK or if the stopping performance is set for coast.

**If DCBRK set to 5.0 seconds and both the FWD and REV terminals activated simultaneously or if a zero speed command is issued, DC current will be applied to the motor at zero speed until one, or both terminals are de-activated.**

**Parameter** **Units** **Level**

**48-DCVLT** - DC Brake Voltage % L2

The parameter controls the amount of DC voltage applied to the motor windings by 47-DCBRK. Factory setting is 2/3 of 52-BOOST. It is adjustable between 0 and 15% of full voltage.

**CAUTION: If DC braking is used as a holding brake, excessive motor heating may result.**

**51-VSEL** - Volts/Hertz Characteristic Selector L2

This parameter selects between the HT mode (Vector Control) and Volts/Hertz operation. By selecting Data Code 6, the WFC<sup>HT</sup> activates the Vector Control scheme. When selecting Data Codes 0 through 5, the Volts/Hertz mode is initiated and one of the three Volts/Hertz characteristics and one of two Torque Boost modes are enabled. The following table defines these selections. Their actions are shown graphically below.

DATA CODE	CHARACTERISTIC	DATA CODE	CHARACTERISTIC
0	Linear – Autoboot	4	Quadratic – Autoboot
1	Linear – Fixed Boost	5	Quadratic – Fixed Boost
2	Semi-Quadratic – Autoboot	6	Vector Control
3	Semi-Quadratic – Fixed Boost		

Note: When selecting the HT mode (Vector Control) parameters 5B-IMAG and 65-SLIP must be activated for high torque, low speed operation. Fine-tune adjustments can be made for optimum performance. Refer to Section 3.9 for proper setup for HT operation.

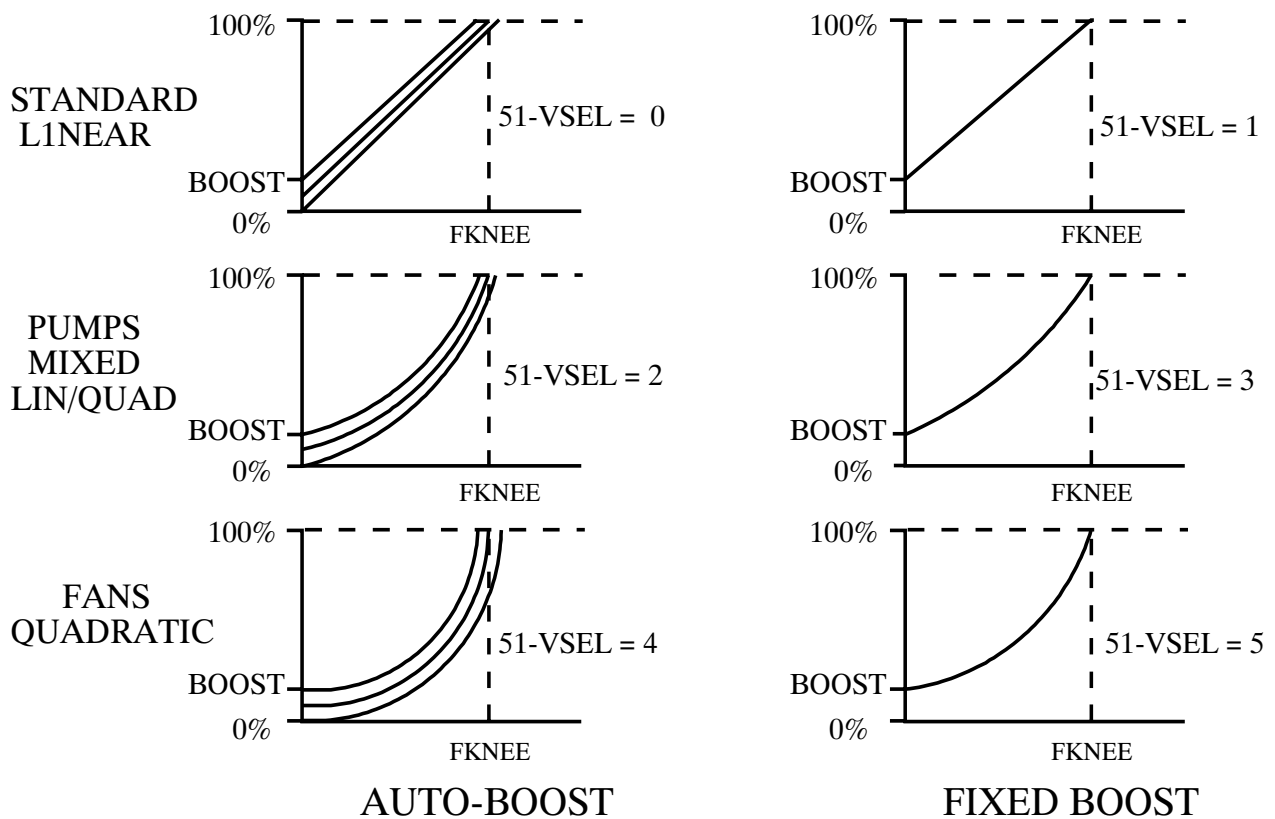

**52-BOOST** - Torque Boost % L1

52-BOOST may be programmed to provide additional starting torque to the motor, if required. It is adjustable in 0.01% increments from 0 to 25%. Factory set BOOST values are model dependent.

**Care must be exercised with this adjustment. Too much boost may cause excessive motor currents and motor heating. Use only as much boost as is necessary to start the motor. AUTOBOOST may be selected at parameter 51-VSEL to provide the optimum value of boost to suit the load automatically. Some 2-pole (3600 RPM synchronous speed) have proven to require less than the default value of 52-BOOST.**

Parameter	Units	Level
<b>53-FKNEE</b> - Volts/Hertz Knee Frequency	Hz	L2
<p>This parameter is used to set the frequency at which full voltage is delivered to the motor. Thereby, the output volts/hertz ratio of the inverter is adjusted. It is adjustable in 0.01 Hz increments from 26 to 640 Hz. It is factory set to the base frequency of U.S. made induction motors, 60 Hz.</p> <p>53-FKNEE sets the point at which the motor goes from constant torque to constant power operation. 32-FMAX determines the maximum operating frequency of the drive.</p> <p>Almost any V/Hz profile can be generated using the WFC<sup>HT</sup> inverter. Consult the factory with your special requirements.</p>		
<b>54-SKBND</b> - Skip Frequency Hysteresis Band	Hz	L2
<p>This parameter sets the range of frequencies (above and below) associated with each of the skip frequencies. Skip bands are used to avoid mechanical resonances in a drive system. The deviation is adjustable in 0.01 Hz increments from 0.20 to 20.00 Hz. The factory setting is 1.00 Hz equating to an overall 2 Hz band.</p>		
<b>55-SK1</b> - Skip Frequency #1	Hz	L2
<b>56-SK2</b> - Skip Frequency #2	Hz	L2
<b>57-SK3</b> - Skip Frequency #3	Hz	L2
<b>58-SK4</b> - Skip Frequency #4	Hz	L2
<p>These four (4) parameters set the center frequency of the skip bands over which normal operation will not be allowed. The inverter will ramp through these frequencies, but not settle on them. Each is adjustable in 0.01 Hz increments from 0.00 to 400.00 Hz.</p>		
<b>59-MVOLT</b> - Rated Motor Voltage	V	L2
<p>59-MVOLT is a parameter active in the 7.5 thru 75 HP models that allows the user to precisely calibrate the inverter to the motor being operated by it.</p> <p>This parameter sets the voltage that the inverter delivers to the motor terminals at the setting of 53-FKNEE. Therefore, it is possible to power the WFC<sup>HT</sup> from 230 VAC and deliver 208 VAC to the motor at 60 Hz, precisely matching the motor's design limits.</p> <p>WFC2000 series drives are calibrated from the factory for 230, with valid settings in the range of 185 to 240. WFC4000 series drives are set for 460, with valid settings between 370 and 480.</p>		
<b>5B-IMAG</b> - Magnetizing Current Level		
<p>This parameter tunes the Vector Control scheme to match motor design. By adjusting this parameter, the inverter-motor combination can be optimized for ideal performance. This parameter becomes active when parameter 51-VSEL is set to a Data Code of 6.</p> <p>The WFC<sup>HT</sup> has an Auto-tune function that will measure the 'no-load' currents and automatically set 5B-IMAG. This occurs after 51-VSEL is set to a Data Code of 6. See Section 3.9 for Auto-tune procedure. Although normally not required, fine-tune adjustments can be made to the parameter after the Auto-tune procedure is completed.</p> <p>The value of 5B-IMAG is adjustable in a range of 15-85% with a model dependent factory setting. Adjustments to the setting can be made using the following formula:</p> $5B-IMAG = \frac{\text{measured no load current}}{IRAT} \times 100$		
<b>61-LTLF</b> - Preset Load Torque Limit Forward	%	L2
<b>62-LTLR</b> - Preset Load Torque Limit Reverse	%	L2
<p>These parameters work in conjunction with 27-TLSEL to set the level at which the inverter goes into torque limit in the forward and reverse motoring modes. When these limits are exceeded, the motor is decelerated at a rate determined by 46-DECTL settling in at the value programmed at 39-FTL. Each is adjustable in 1% increments from 5 to 150% of drive rating.</p> <p><b>If 39-FTL is set to a value greater than 32-FMAX, torque limiting will be disabled.</b></p>		
<b>63-RTL F</b> - Preset Regenerative Torque Limit Forward	%	L2
<b>64-RTL R</b> - Preset Regenerative Torque Limit Reverse	%	L2
<p>These parameters work in conjunction with 27-TLSEL to set the level at which the inverter goes into torque limit in the forward and reverse regenerative modes. When these limits are exceeded, the motor is accelerated at a rate determined by 46-DECTL toward 32-FMAX. Each is adjustable in 1% increments from 5 to 110% of drive rating.</p> <p><b>If 39-FTL is set to a value greater than 32-FMAX, torque limiting will be disabled.</b></p>		

<b>Parameter</b>	<b>Units</b>	<b>Level</b>
------------------	--------------	--------------

**65-SLIP - Slip Compensation**

Slip compensation is used to provide a more constant output speed as motor loading changes. This parameter is used in both the Volts/Hertz and High Torque modes of operation. **Too much slip compensation may result in unstable motor operation. It is not intended for use with a synchronous motor.** In Volts/Hertz mode, the inverter's output frequency is increased as the motor loading increases. In HT mode (Vector Control), the setting of 65-SLIP is the nominal full load speed compensation for the motor. This setting is required for optimum performance at low speeds.

65-SLIP is programmable in 0.01% increments from 0.00 to 10.00%. See the following formula and example to determine the proper setting of parameter 65-SLIP:

Example: Assume the use of a 1740 RPM motor with a nameplate current (Im) rating of 9.6 amperes. From Section 1.5 or parameter 03-IRAT, we determine that the drive is rated at 15.2 amperes. From Section 1.6, we can determine that the synchronous (unloaded) speed of the motor to be 1800 RPM. Using the formula, we find:

$$65-SLIP = \frac{RPMs - RPM1}{RPMs} \times \frac{IRAT}{Im} \times 100(\%) = \frac{1800 - 1740}{1800} \times \frac{15.2}{9.6} \times 100\% = 5.27\%$$

**66-STAB - Current Stability Adjustment**

L2

Lightly loaded motors may tend to oscillate and become unstable due to electro-mechanical relationships in the motor. This may be more prevalent when the inverter capacity is larger than the motor. This adjustment will stabilize the motor current in these conditions. The range of adjustment is 0 through 4, with the default being 2. Some 2-pole (3600 RPM synchronous speed) motors have proven to require alteration of this parameter to assure stable operation.

**67-TOL - Timed Overload Trip Point**

%

L1

67-TOL is the timed overload trip point. This parameter defines the load point beyond which a timed electronic trip can occur. The trip time depends on the amount of overload and is 1 minute for 150% of the setting, longer for lesser degrees of overload. A 10% overload will not cause the drive to trip. Parameter 67-TOL is adjustable in 1% increments from 5 to 100% of drive capacity. The factory setting is 0, inactive.

TRIP TIME [SECS]

A	B	C
36	180	360

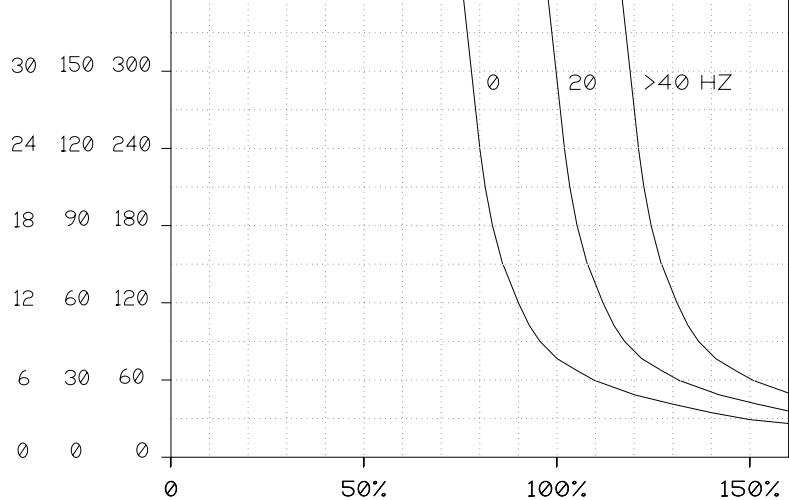

The action of 67-TOL is presented graphically in the Trip Time chart to the right. See also parameter 6A-TOLC for information on setting timed overload appropriately for your motor.

The proper setting of parameter 67-TOL is calculated using the value stored at 03-IRAT and the motor nameplate current (Im) according to the following formula:

$$67-TOL = \frac{Im}{IRAT} \times 100\%$$

**WARNING**

**WHEN USING MULTIPLE MOTORS ON A SINGLE INVERTER, USE SEPARATE EXTERNAL PROTECTION ON EACH MOTOR AND SET 67-TOL TO 0 (DISABLED).**

**AVERTISSEMENT**

**AVEC L'UTILISATION DE PLUSIEURS MOTEURS SUR UN SEUL INVERSEUR, UTILISEZ UNE PROTECTION EXTREME SEPARÉE SUR CHAQUE MOTEURS ET PROGRAMMEZ 67-TOL À 0.**

**Parameter** **Units** **Level**

**68-NRST** - Trip Restart Number L2

Providing the inverter is operated from a maintained run command, this parameter will allow the drive to be automatically restarted, after a fault, up to a programmed number of attempts. This limit is from zero (0) up to a maximum of eight (8) tries within a 10 minute time frame. In each case, the drive will wait for the delay programmed at 69-DRST. Only fault codes F11 thru F20 are effected by this process. Once the programmed value of 68-NRST has been exceeded, the drive will display a F10 fault and wait for a manual reset.

**When 68-NRST is active, the function of parameters 72-ST1, 73-ST2, 74-ST3 and 75-STR is altered. Data Code (2) for each parameter will not activate the respective output for every fault, only for fault codes 1-10. To maintain a similar, yet inverse function with 68-NRST active, use data code 1.**

**WARNING**

**INSURE THAT AUTOMATIC RESTARTING WILL NOT CAUSE DAMAGE TO EQUIPMENT OR INJURY TO PERSONNEL.**

**AVERTISSEMENT**

**ASSUREZ VOUS QU'UN DEPART AUTOMATIQUE N'ENDOMMAGERA PAS L'EQUIEMENT OU DE BLESSURE AU PERSONNEL.**

**69-DRST** - Trip Restart Time Delay s L2

If 68-NRST is greater than 0, the inverter will wait the programmed time value after a fault before re-starting. Restart performance will be governed by parameter 82-START. DRST is programmable in 0.01 sec. increments from 0.00 to 60.00 seconds.

**6A-TOLC** - Timed Overload Characteristic L2

6A-TOLC works in conjunction with 67-TOL to customize the overload characteristics of the inverter to the driven motor. Refer to the graph presented with parameter 67 for a more in-depth understanding of this parameter.

Data Code	Tripping Characteristic	Trip Time (Seconds)*	Scale	Motor Type
0	Normal – Reduced threshold below 40 Hz	60	C	Standard Induction
1	Medium – Reduced threshold below 40 Hz	30	B	Standard Induction
2	Fast – Reduced threshold below 40 Hz	10	A	Standard Induction
3	“Shear Pin” – Reduced threshold below 40 Hz	0**	–	Standard Induction
4	Normal – Constant torque	60	C	Inverter Duty
5	Medium – Constant torque	30	B	Inverter Duty
6	Fast – Constant torque	10	A	Inverter Duty
7	“Shear Pin” – Constant torque	0**	–	Inverter Duty

\*Trip time is at 150% of 67-TOL setting      \*\*Trip time is at 110% of 67-TOL setting

**70-MCAL** - Analog Meter Output Calibration L2

This parameter adjusts the meter output value at terminal MET. The full scale output is programmable from 0 to 255 which corresponds to approximately 0 to 16.5 VDC. Factory default is for 10 VDC at terminal MET at nominal full scale output. 70-MCAL can be programmed while the inverter is running.

**71-METER** - Analog Meter Output Selector L1

71-METER defines what the analog meter output (terminal MET) will indicate. The data is defined as:

Data Code	Description
0	Output inactive.
1	Output proportional to output frequency (12-FOUT) with full scale at 32-FMAX.
2	Output proportional to output voltage (13-VOUT) with full scale at 100%.
3	Output proportional to output current (14-IOUT) with full scale at 200% of drive rating.
4	Output proportional to drive load (15-LOAD) with full scale at 200%.
5	Output proportional to load torque (16-TORQ) with full scale at 200% torque.
6	Output proportional to stator frequency (1A-FOUT2) with full scale at 32-FMAX.
7	Output proportional to feedback encoder frequency (A7-OPTA7) with full scale at 32-FMAX. (Used with WPC04, see section 6.2 and Form 1032)

The full scale calibration is adjustable by programming of parameter 70-MCAL.

Parameter	Units	Level
<b>72-ST1</b> - Auxiliary Output #1 (Open Collector)		L2
<b>73-ST2</b> - Auxiliary Output #2 (Open Collector)		L2
<b>74-ST3</b> - Auxiliary Output #3 (Open Collector)		L2
<b>75-STR</b> - Auxiliary Relay Output		L1

Each of these parameters work similarly with the open collector outputs at the terminal strip (designated ST1, ST2 and ST3) and the auxiliary relay. The data code programmed at these parameters defines the condition that activates that particular output (either open collector or relay). Each may be programmed as follows to indicate:

Data Code	Description
<b>0</b>	Output inactive.
<b>1</b>	No fault (becomes active when the inverter is ready).
<b>2</b>	Fault (refer to parameter 68-NRST for further information).
<b>3</b>	Motor running FWD or REV.
<b>4</b>	Motor running REV.
<b>5</b>	Motor running FWD.
<b>6</b>	Motor speed = 0 Hz.
<b>7</b>	Motor at speed.
<b>8</b>	Motor speed greater than value programmed at parameter 36-F5.
<b>9</b>	Drive operating in torque limit.
<b>10</b>	Drive operating near overtemperature limit.
<b>11</b>	Drive operating in LOCal Mode.

**77-MOL** - Motor Overload Input  
Sets Motor Overload Input Polarity.

Data Code	Description
<b>0</b>	Removal of high input (+24 VDC) from MOL causes an F07 Fault (N.C. operation)
<b>1</b>	High input on MOL will cause an F07 Fault (N.O. operation)

**81-PRGNO** - Special Program Number L2

This parameter allows the storage, retrieval and exchange of customer defined program setups, as well as a means of returning all parameters to factory defaults. Numerous special programs are also included at this parameter. Standard data codes are outlined in the following table:

Data Code	Description	See Note
<b>0</b>	Standard Factory Program	1
<b>1</b>	Reset all parameters to factory settings	1, 2
<b>2</b>	Store customer parameter settings	1, 3
<b>3</b>	Recall customer parameter settings	1, 3
<b>4</b>	Exchange current with stored customer parameter settings	1, 3
<b>5</b>	Recalibration of a WFC2005-0x for use with a 3 HP motor from a single phase source	1, 4
<b>10</b>	Makes option parameters inaccessible	1
<b>11</b>	Makes option parameters accessible for viewing and change	1
<b>30-31</b>	EMOP and 5-speed operation (Crane & Hoist Industry, See Form 1041)	5
<b>32-33</b>	EMOP2 / EMOP3 Electronic Motorized Potentiometer speed control	5, 6
<b>60-62</b>	Program Sequencer (See the following discussion)	
<b>200-201</b>	Reference Signal Reversing (See Form 1042)	5, 7

**NOTES:**

- When data codes 1-29 are invoked, 81-PRGNO will revert to "0" upon exiting the program mode. When data codes greater than 29 are used, 81-PRGNO will retain the data setting.
- Data code 1 allows all program parameters to be returned to factory defaults. When the program mode is exited, the display will indicate "INIT PARAMETERS" then "RESTART".
- Data code 2 allows storage of the current set of program parameters. Data code 3 allows a previously stored set of program parameters to be retrieved. Data code 4 allows the current and stored set of program parameters to be exchanged.
- Data code 5 allows the WFC2005-0x to be re-calibrated for use on a 3 HP motor when powered from a single phase source. Use data code 1 to return to the 5 HP calibration.
- Parameter 21-MODE must be set to a code that permits MODE 2 (REMOte) operation. Also, the drive must be operated in REMote mode.
- Data codes 32 and 33 select the WFC<sup>HT</sup>'s EMOP control programs. With code 32 selected, commanded output frequency returns to 31-FMIN when the drive is stopped. With code 33 selected, commanded output frequency remains at the previous setpoint. See the table above for proper usage.
- These codes permits both speed and direction control from an analog speed input. Order Form 1042 for more details.

Functional Description	EMOP2/EMOP3 Data Code 32/33			
	Terminals			
	FWD	REV	PS1	PS2
Off	0	0	X	X
Speed = 0	1	1	X	X
FWD Decrease Speed	1	0	1	X
FWD Hold Speed	1	0	0	0
FWD Increase Speed	1	0	0	1
REV Decrease Speed	0	1	1	X
REV Hold Speed	0	1	0	0
REV Increase Speed	0	1	0	1

0 = Inactive 1 = Active X = Ignored

**Program Sequencer**

The Program Sequencer function can be thought of as a simple programmable logic controller (PLC). It permits the drive to execute up to nine (9) sequential program steps. Each program step can be an independent combination of direction, speed and ramp. The duration of any one program step can be controlled by: time, digital comparison, pulse (event) count or an analog voltage level. Use of the pulse count and voltage level comparisons requires the use of either the WPC04 – Encoder Interface Board or WPC05 – Process Control Interface Board (see Table 4.2 for details). An Event Control parameter (C1-CNTL1...C9-CNTL9) and an Event Count parameter (E1-ECNT1...E9-ECNT9) serve to define each program step independently.

**Event Control Parameters**

The Event Control Parameters (C1-CNTL1...C9-CNTL9) define the direction, speed, acceleration/ deceleration time and duration of each program step. Each is programmed as a string of 8 characters or "bits." Figure 4.1 defines the bit coding:

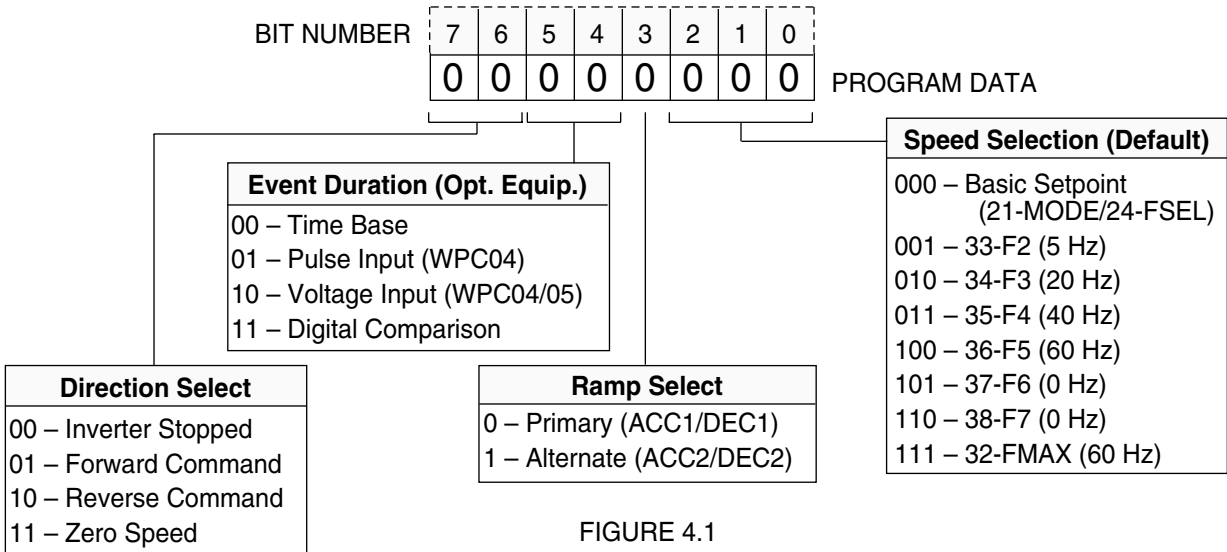

FIGURE 4.1

**Event Count Parameters**

The Event Count Parameters (E1-ECNT1...E9-ECNT9) define the duration of each program step. Each Event Count Parameter is associated with a corresponding Event Control Parameter (That is parameter E1-ECNT1 determines the duration of C1-CNTL1; E2-ECNT2 determines the duration of C2-CNTL2, etc.). The data entered can represent time, pulse counts, digital comparison or an analog voltage level as defined in Table 4.1. The range of data that can be entered in each Event Count Parameter is 0 to 65,000.

Bits 5 & 4 define the event duration for each program step. Note that the controlling factor for the duration may be different for each step.

Bit #		Description of Event Count Parameter Units	Optional Equipment Required?				
5	4						
0	0	<b>Time Base</b> – The operating condition outlined in the Event Control parameter will be executed for a time interval of up to 18 hours (dependent on the setting of 81-PRGNO). The next event will then be executed, up through Event #9.	No				
		<b>81-PRGNO</b>		Time Base Increments	Maximum Sequence Time		
		<b>60</b>		1 second	18.2 hour		
		<b>61</b>		0.1 second	1.8 hour		
	<b>62</b>	0.0082 second	8.9 minutes				
0	1	<b>Pulse Count</b> – The operating condition outlined in the Event Control parameter will be executed until the set number of pulses have been counted. The pulse count is provided by either an encoder or proximity sensor mounted on the driven machine.	Yes – WPC04				
1	0	<b>Analog Input</b> – The operating condition outlined in the Event Control parameter will be executed until a voltage is greater or less than a programmed value. The limits of the analog level are 0-10.00 VDC.	Yes – WPC04 or WPC05				
		Ex-ECNTx Range (DC voltage)		Description			
		00000-01000 (0-10 VDC)		<b>Lower Limit</b> – The Event Control parameter will be executed until a voltage equal to or LESS than the programmed value is sensed.			
		10000-11000 (0-10 VDC)		<b>Upper Limit</b> – The Event Control parameter will be executed until a voltage equal to or GREATER than the programmed value is sensed.			
1	1	<b>Digital Comparison</b> – The operating condition outlined in the Event Control parameter will be executed until a set digital combination of terminals PS1, PS2 and PS3 is sensed by the inverter. The limits of this configuration are 0 thru 7, signifying the binary combinations of PS1, PS2 and PS3.	No, but compatible with WPC02 & WPC06				
		Ex-ECNTx Code		Description	Control Terminals		
					PS1	PS2	PS3
		<b>0</b>		All inputs inactive	0	0	0
		<b>1</b>		PS1 Active	1	0	0
		<b>2</b>		PS2 Active	0	1	0
		<b>3</b>		PS1 & PS2 Active	1	1	0
		<b>4</b>		PS3 Active	0	0	1
		<b>5</b>		PS1 & PS3 Active	1	0	1
		<b>6</b>		PS2 & PS3 Active	0	1	1
<b>7</b>	PS1, PS2 & PS3 Active	1	1	1			

TABLE 4.1

**Activating the Program Sequencer function requires that a selection of 81-PRGNO = 60, 61 or 62 be made. This must be done regardless of the type of event count used for the individual sequence steps. After 81-PRGNO is set to 60, 61, or 62, exit the program mode by pressing the PROG key. The Event Control and Event Count parameters will be visible upon re-entering Level 2 programming.**

#### Programming the Event Control Parameter

Determine the coding of the control byte for each program step using Figure 4.1. Enter the first code into parameter C1-CNTL1. When you access parameter C1, the display will resemble the following:

To program this parameter:

1. Press **SHIFT** to open the parameter. The parameter number will flash and bit number 7, or the left-most character will be underlined, indicating that this character may be changed.
2. Use the up arrow to increment the character. Use the down arrow to decrement the character.
3. Press **SHIFT** again to move on to the next character, bit number 6, and repeat step 2.
4. Once all the characters or bit numbers have been changed, press **ENTER** to store the result.

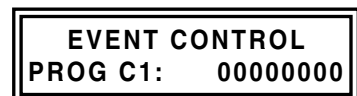

### Programming Example

A machine is required to run in the forward direction at 50 Hz for one hour, then quickly decelerate to a stop. After two (2) minutes, the machine must accelerate in the reverse direction to 5 Hz until a limit switch is activated causing the drive to decelerate to a stop. The following three (3) sequential steps can be programmed using only the basic inverter and no optional equipment.

	SEQ1	SEQ2	SEQ3
<b>Direction Selection</b>	Forward	Stop	Reverse
<b>Event Definition</b>	1 Hour	2 Minutes	Until PS1 Active
<b>Ramp Selection</b>	Primary	Alternate	Primary
<b>Speed Selection</b>	F6 (50 Hz)	N/A	F2 (5 Hz)

TABLE 4.2

First, since two of the sequential steps are time based, the proper 81-PRGNO setting must be determined.

Determine the resolution and the maximum time required, in this case one (1) hour. If a resolution of one second is sufficient, set 81-PRGNO = 60. If a greater setting resolution is necessary, 81-PRGNO can be set to 61 (0.1 second

PARAMETER	DATA CODE	EXPLANATION
81-PRGNO	60	1 Second Time Increments
C1-CNTL1	01000101	FWD/Timed/Primary Ramp/Preset Speed F6
C2-CNTL2	00001000	STOP/Timed/Alt. Ramp/Speed Setting Ignored
C3-CNTL3	10110001	REV/Digital Comparison/Primary Ramp/Preset Speed F2
E1-ENCT1	3600	1 Hour = 3600 Seconds
E2-ENCT2	120	2 Minutes = 120 Seconds
E3-ENCT3	1	Terminal PS1 Active

TABLE 4.3

Graphically the results of this programming could be represented as shown to the right:

If E4-ENCT4 thru E9-ENCT9 are set to zero, they will be ignored by the sequencer function. If the inverter's forward terminal were still active, the sequence would repeat; if not, the sequence would be executed one (1) time only. The control's stop key continues to function as an emergency stop to abort the cycle at any time.

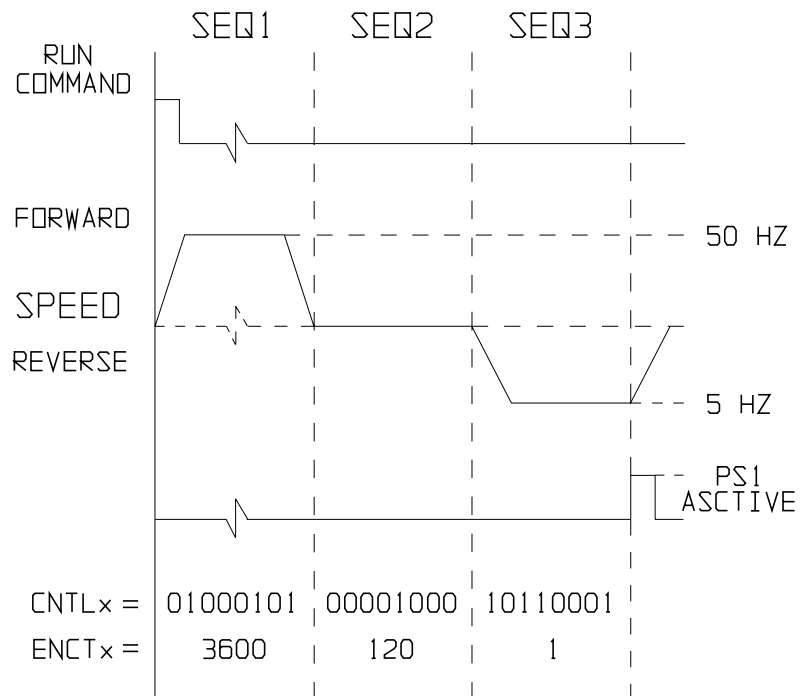

FIGURE 4.2

### WFC<sup>HT</sup> Operation Under Program Sequencer Control

The WFC<sup>HT</sup> can be operated under control of the Program Sequencer from either the keypad or from the terminal strip. See Parameter 21-MODE (Section 4.2 and Table 4.4).

When operating from the keypad, pressing the FWD key will command the drive to cycle through the programmed steps of the Program Sequencer one time only. Pressing the SHIFT and FWD keys simultaneously will cause the programmed sequence to repeat until the stop key is pressed.

When operating from the terminal strip using remote operators, the same possibilities exist. If operating under three wire control, with the R/J terminal active, momentarily activating the FWD terminal will force the programmed sequence to be executed once. If the FWD terminal is activated continuously, the programmed sequence will be repeated. When a stop command is issued to the drive, it will reset the Program Sequencer to the beginning and await the next start command. If the CTS terminal is activated, the Program Sequencer pauses at the Current Step.

21-MODE Setting	LOCal	REMote	Transfer by
0/10	Sequencer operation from keypad	N/A	N/A
1/11	Normal keypad operation	Sequencer operation from keypad	LOC/REM key
2/12 3/13	Normal keypad operation	Sequencer operation from terminal strip	LOC/REM key
4/14 24/34	N/A	Sequencer operation from terminal strip	N/A
21/31	Normal keypad operation	Sequencer operation from keypad (Note 1)	PS3
22/32 23/33	Normal keypad operation	Sequencer operation from terminal strip (Note 1)	PS3

Note 1: Terminal PS3 is not available under these selections of 21-MODE for digital comparison.

TABLE 4.4

**The Program Sequencer cannot be run under SIO control. The individual program parameters may be downloaded to the control via SIO communication.**

The program sequence can be single-stepped through by repeatedly pressing the LOCAl/REMote key. If, for example, long time delays were programmed at several steps of the Program Sequencer, it would be possible to disregard these long-time intervals to verify program functions.

### Other Software Features

During program sequence operation the first four (4) characters of the keypad display will show the sequence step being executed (SEQ1, SEQ2 ... SEQ9). See Section 3.6 description of displays.

Parameter A8-OPTA8 is available for viewing during the execution of the programmed sequence steps. This parameter allows the viewing of elapsed time during the sequence, if using the time base option. If using the event count option, this will be a real time events counter. Parameter A8 can allow the user to monitor where the drive is operating relative to the entire sequence and when you can expect the next step to begin.

Parameter A9-OPTA9 can be used in conjunction with A8 since it displays the actual step number of the sequence (0-9).

Parameter B7-NENC is used as a prescaler for the Event Count parameter when operating in the Pulse Count mode (using the WPC04 Encoder Interface Board). For example, if B7 is set to 10, the inverter will receive 10 pulses before considering one (1) event complete. This is useful when very high pulse counts are needed. **The maximum frequency of the input pulses is 60 Hz.**

### Event Sequencer Worksheet

Refer to the previous discussion and fill in the appropriate codes for **Cx-CNTLx** and **Ex-ECNTx** in Table 4.5. To skip all remaining events, ensure that the respective **Cx** and **Ex** values are set to zero.

Event #	Param/Bit #	7	6	5	4	3	2	1	0
1	C1-CNTL1								
	E1-ECNT1								
2	C2-CNTL2								
	E2-ECNT2								
3	C3-CNTL3								
	E3-ECNT3								
4	C4-CNTL4								
	E4-ECNT4								
5	C5-CNTL5								
	E5-ECNT5								
6	C6-CNTL6								
	E6-ECNT6								
7	C7-CNTL7								
	E7-ECNT7								
8	C8-CNTL8								
	E8-ECNT8								
9	C9-CNTL9								
	E9-ECNT9								

TABLE 4.5

**Parameter****Units****Level****82-START** - Inverter Start Options

L2

This parameter selects options such as line start lockout, line starting or starting a rotating motor. 82-START also allows the keypad STOP key to function as an emergency stop when operating the inverter from the terminal strip. Various options for 82-START include:

DATA CODE	DESCRIPTION
<b>0</b>	Line start lockout. When the inverter is configured for terminal strip operation with a maintained run command present, it will not start upon the application of line power. The direction command must be removed and re-established to start the drive. The keypad STOP functions as an EMERGENCY STOP when controlling the inverter from the terminal strip. Recovery from an EMERGENCY STOP will require that the STOP key be pressed a second time and then the direction command re-established.
<b>1</b>	Line start (Autostart). With this setting, the drive will turn on when power is applied and a direction command is present. The STOP key is configured as an EMERGENCY STOP when operating from the terminal strip.
<b>2</b>	This setting allows the drive to successfully start a rotating motor. Line Start Lockout is active. The STOP key functions as an EMERGENCY STOP when operating from the terminal strip.
<b>3</b>	Start into a rotating motor with Autostart. STOP key enabled.
<b>4...7</b>	Same start functions as 0 thru 3, but STOP key totally disabled in terminals mode.

**WARNING**

**INSURE THAT AUTOMATIC RESTARTING WILL NOT CAUSE DAMAGE TO EQUIPMENT OR INJURY TO PERSONNEL.**

**ADVERTISSEMENT**

**ASSUREZ VOUS QU'UN DEPART AUTOMATIQUE N'ENDOMMAGERA PAS L'EQUIEMENT OU DE BLESSURE AU PERSONNEL.**

Note: When data codes 2, 3, 6 or 7 are selected, the display will indicate SPD SEARCH upon the initiation of a run command.

**Parameter****Units****Level****83-PWM - PWM Carrier Frequency Selector**

L2

This parameter sets the carrier frequency of the Pulse-Width-Modulation waveform supplied to the motor. Low carrier frequencies provide better low end torque but produce audible noise from the motor. Higher carrier frequencies produce less audible noise, but cause more heating in the inverter. The WFC<sup>HT</sup> is rated to produce continuous full load current at rated ambient temperatures when parameter 83-PWM is set to carrier frequencies 3, 4, 6 or 8 kHz. **At higher carrier frequencies (12 and 16 kHz), the inverter will automatically switch to a lower carrier frequency when load conditions exceed the derating levels. When the load is reduced, the carrier frequency will return to its previous setting.** Data Code 0 (Autoselect) automatically selects the highest carrier frequency permitted without overheating the inverter. Note: Autoselect will also adjust the carrier frequency to 8 kHz at 75° C and to 4 kHz at 90° C. When using Data Codes 5 & 6, the carrier frequency will shift to 1/2 of the selected carrier frequency when the output voltage is less than 6% of nominal rating. When using Data Codes 7 and 8, the carrier frequency will shift to 1/2 of the selected carrier frequency when the output voltage is less than 12% of nominal rating and to 1/4 of the selected carrier at 6% of nominal output voltage. **For low speed high torque applications, the best performance can be achieved by selecting Data Codes 1, 2, 7 or 8.** Adjustments are as follows:

DATA CODE	MAXIMUM MOTOR FREQUENCY (Hz)	CARRIER FREQUENCY (kHz)	CARRIER FREQUENCY (kHz) @ 12% Vout	CARRIER FREQUENCY (kHz) @ 6% Vout
0	400	Autoselect	Autoselect	Autoselect
1*	260	3	3	3
2	350	4	4	4
3	400	6	6	6
4	400	8	8	8
5	400	12	12	6
6	400	16	16	8
7	400	12	6	3
8	400	16	8	4

\*Factory Setting

### Drive Derating at high carrier frequencies

The chart below shows the derating of the WFC<sup>HT</sup> Series AC inverters at the designated carrier frequencies. Note that the derating at certain carrier frequencies is identical to an adjacent frequency. Therefore, there are three derating values over the six carrier frequency selections.

MODEL	CONTINUOUS LOAD RATING @ 3 & 4 KHZ	CONTINUOUS LOAD RATING @ 6 & 8 KHZ	CONTINUOUS LOAD RATING @ 12 & 16 KHZ
WFC1001-0	110%	110%	110%
WFC2000-7	110%	110%	110%
WFC2001-0	110%	110%	110%
WFC2002-0	110%	110%	110%
WFC2003-0	110%	110%	82%
WFC2005-0	110%	110%	64%
WFC2007-5	110%	110%	110%
WFC2010-0	110%	110%	100%
WFC2015-0	110%	110%	110%
WFC2020-0	110%	110%	96%
WFC2025-0	110%	110%	86%
WFC4001-0	110%	110%	110%
WFC4002-0	110%	110%	110%
WFC4003-0	110%	110%	110%
WFC4005-0	110%	110%	90%
WFC4007-5	110%	110%	110%
WFC4010-0	110%	110%	110%
WFC4015-0	110%	110%	110%
WFC4020-0	110%	110%	69%
WFC4025-0	110%	110%	110%
WFC4030-0	110%	110%	110%
WFC4040-0	110%	95%	62%
WFC4050-0	110%	78%	51%
WFC4060-0	110%	79%	65%
WFC4075-0	110%	83%	57%
	See Note	See Note	See Note

Note: Due to the internal temperature rise of the WFC4075-0, 75 HP models, the adjustability of parameter 83-PWM will be limited. The chart below shows the selections available for the WFC4075-0 models only. All other models will program according to the chart on the preceding page.

### De-rating table for WFC4075-0 models only

DATA CODE	MAXIMUM MOTOR FREQUENCY (Hz)	CARRIER FREQUENCY (kHz)	CARRIER FREQUENCY (kHz) @ 12% Vout	CARRIER FREQUENCY (kHz) @ 6% Vout
0	400	Autoselect	Autoselect	Autoselect
1	260	2.3	2.3	2.3
2	350	2.5	2.5	2.5
3	400	4.6	4.6	4.6
4	400	5	5	5
5	400	9.2	4.6	4.6
6	400	10	5	5
7	400	9.2	4.6	2.3
8	400	10	5	2.5

**Parameter** **Units** **Level**

**84-DISP - Display Option Full Setting** L2

Parameter 84-DISP, along with parameter 85-UNITS, allows the bottom line of the keypad display to be programmed in engineering units such as RPM, Bottles per hour - BPH or any desired unit up to five characters long.

With factory default setting of "0", the display will present the commanded output frequency being delivered to the motor. As long as the speed command does not change, the display will not change.

With data code "1" selected, the operating display will change as the inverter makes changes in the output frequency to maintain commanded performance (stator frequency). For example, slip compensation and regenerative current limit make changes in the stator frequency (See parameter 1A-FOUT2, an option parameter). For more information on option parameters, see parameter 81-PRGNO.

The basic question that must be answered is, "What numeric indication do we want the display to indicate at if we're operating at maximum frequency (parameter 32-FMAX)?" This value may be modified to compensate for the number of decimal places programmed at parameter 85-UNITS. For example, to indicate 1800.0 RPM on the display at FMAX = 60 Hz, enter 18000 at parameter 84-DISP. Entries must be within the range of 10-65000.

**85-UNITS - Display Units Setting** L2

The programming for 85-UNITS is different from most parameters, in that the keypad keys operate differently. The UNITS identifier has up to a six-character format with each of the first five characters having the ability to display characters from the following list:

**blank, #, %, +, -, ., /, 0 thru 9, :, <, =, > and A thru Z**

The last character is a number between 0 and 9. If this value is set between 0 and 5, it will assign the position of the decimal place in the engineering units display. The factory setting is "R P M \_ \_ 1" which will display the value programmed at 84-DISP with one decimal place.

If the last character is selected to be "9", the **retention time** function is invoked. This is, rather than a frequency / speed proportional output, a reciprocal function. The maximum display is 655.34 (dependent on the value programmed at 84-DISP); at output frequencies less than that, or less than 3.2 Hz, the display will indicate " \_ \_ . \_ \_ ". Two decimal places are maintained in this mode of operation and cannot be changed.

**Retention Time Example -**

Assume the following program settings:  
 32-FMAX = 60 Hz  
 31-FMIN = 10 Hz  
 84-DISP = 1000  
 85-UNITS = MIN\_\_9

The display versus output frequency would be:

Motor Frequency	Display
60	10.00 MIN
40	15.00 MIN
30	20.00 MIN
20	30.00 MIN
10	60.00 MIN

To program 85-UNITS:

1. Press the STOP key if the inverter is running.
2. Hold the SHIFT key while pressing the PROGram key to enter Level 2.
3. Press the SHIFT key. The cursor will appear under the leftmost character in the data field.
4. Use the UP/DOWN arrow keys to scroll through the available choices.
5. Press the SHIFT key to move the cursor one place to the right.
6. Repeat steps 4 & 5 to complete the character selections.
7. The sixth position requires a number from 0-9 and either determines the number of decimal places in the display or whether the retention time function is activated.
8. Press the ENTER key to store the engineering units display in memory or the SHIFT key to move the cursor back to the first position.



After 84-DISP and 85-UNITS have been set, the inverter output will be set and displayed in the engineering units format.

**Parameter****Units****Level****86-LANG** - Display Language

L2

This parameter sets the language for the display readout. The factory can supply a complete listing of displays in all languages. The options include:

DATA CODE	LANGUAGE
0	English
1	Spanish
2	French
3	German

**87-ACODE** - Security Access Code

L2

This parameter allows the user to control access to the programmable functions of the inverter. The initial value of 87-ACODE is 000, that results in no access code being necessary. Any number between 001 and 999 may be used for an access code, but is not necessary.

To enter an access code, simply re-program parameter 87 as though you would any other parameter. After you have stored this new value, you will have ten minutes of free access. If you remove power and re-establish it, you will need to enter the access code to change any program parameter.

If you enter an incorrect access code, the inverter will display **\*\*WRONG CODE\*\*** and allow only VIEWing rights to the various parameters. Once the correct code is entered you again have 10 minutes of free access unless power is removed and re-applied.

To disable the access code requirement, set 87-ACODE back to 000.

**88-FRO** - Frequency Reference Output

This parameter determines the frequency pulse-train output from the 6FS terminal. Each of the frequency outputs can be used as a speed reference input to another WFC<sup>HT</sup> series inverter. See parameter 24-FSEL for additional information. Note that the pulse train from the 6FS terminal is rated at approximately a 30% duty cycle.

DATA CODE	DESCRIPTION
0	6 times operating frequency
1	48 times operating frequency

**A2-RATIO** - Master / Slave Speed Ratio

L2

A2-RATIO allows the 6FS output of one WFC<sup>HT</sup> series inverter (master) to be used to control the speed of up to eight (8) other (slave) inverters. The output of each slave unit can be individually programmed, or trimmed "ON-THE-FLY" with A2-RATIO. The range of adjustment is 0-200% of the master.

See Section 6.3 - Application Hints for further information.

**B1-OPTNO** - Option Board Number

L2\*

This parameter serves as an excellent diagnostic tool. It indicates which, if any, of the WPC style option cards have been installed in the WFC<sup>HT</sup> inverter. For instance, if the WPC01 Isolated Analog and Digital Output Card has been installed in the drive, B1 would indicate "1". If no card is in the drive or if the card is not recognized by the drive, B1 would indicate "0".

## SECTION 5

### LEVEL 3 PARAMETER DESCRIPTIONS AND PROGRAMMING

The following is a summary of the parameters associated with SIO communication. Consult Form 997 - **SIO Serial Link Protocol** or the factory for more information on the use of WFC<sup>HT</sup> Series inverters in serial communication applications.

#### 5.1 Program Code Summary (Level 3)

#	Name	Description	Data Range	Factory Setting	Units	Access Level	See Page	Customer Setting
04	TMAX	Maximum Heatsink Temperature	60-100	85	C	3	45	
0A	CFLT	Current Fault	---	---	---	3	45	
11	STAT	Inverter Status Byte	BINARY (8)	---	---	3	45	
22	FNCT	Inverter Operating Function	0-4	---	---	3	46	
23	CNTL	Control Information Byte	BINARY (8)	---	---	3	47	
25	FEXT1	External Speed #1	0.00-400	0	Hz	3	47	
26	FEXT2	External Speed #2	0.00-400	0	Hz	3	47	
28	TLEXT	External Torque Limit Reference	0-150	0	%	3	47	
29	COU	Control Output Status	BINARY (8)	---	---	3	47	
7A	CIN	Control Board Terminal Status	BINARY (8)	---	---	3	48	
7B	CIN2	Option Board Terminal Status	BINARY (8)	---	---	3	48	
7C	FIN	Control Board Analog Input Status	0-32768	0	---	3	48	
7D	FAUX	Option Board Analog Input Status	0-32768	0	---	3	48	
7E	LIM	Analog Torque Limit Input Status	0-15000	15000	---	3	48	
91	SIOC	SIO Communication BAUD Rate	0-7	0	---	3	48	
92	SIOA	SIO Slave Address	1-94	1	---	3	48	
93	SIOT	SIO Watchdog Timer	0.00-60.00	0.00	s	3	48	
94	SIOF	SIO Fault Byte	BINARY (8)	---	---	3	49	
95	SIOP	SIO Protocol	0-3	0	---	3	49	

#### 5.2 Programming

To change the default programming for a given parameter from the keypad:

- A. Press the **STOP** key, if the inverter is running. Some parameters (see the individual parameter description) can be changed while the inverter is operating.
- B. To enter Level 1 programming, press the **PROGRAM** key. To enter Level 3, hold the **SHIFT** key and press the **PROGRAM** key.
- C. Use the **UP/DOWN** arrow keys to select the program parameter for change.
- D. Press the **SHIFT** key. The program number will blink indicating that the data value may be changed.
- E. Use the **UP/DOWN** arrow keys to select the new data code.
- F. Press the **ENTER** key. The display will indicate **\*\*STORED\*\*** for one second, then revert to the normal parameter display.
- G. Press the **PROGRAM** key to exit the programming mode or the **UP/DOWN** arrow keys to select a new parameter for change.

<b>SIO SLAVE ADDR</b> <b>PROG 92: 1</b>
--

### 5.3 Parameter Descriptions

This section provides a functional description of all WFC<sup>HT</sup> programming parameters at Level 3. Those with a level indication including an asterisk (\*) cannot be programmed, but can be viewed while the drive is operating.

<b>Parameter</b>	<b>Units</b>	<b>Level</b>
------------------	--------------	--------------

<b>04-TMAX</b> - Maximum Heatsink Temperature	C	L3*
---	---	-----

This parameter is factory set to the maximum heat sink temperature that the processor will allow continuous operation of the drive. The inverter's display will indicate HI TEMP at TMAX minus 8PC. The data type for 04-TMAX is a real number.

<b>0A-CFLT</b> - Current Fault		L3
--------------------------------	--	----

This parameter is accessible serially in the event of a fault to determine the cause of a fault. It is stored as an integer value with fault code (See Section 7) and elapsed time available to the host computer. Refer to Section 4 for a more thorough discussion of fault codes (07-FLT3, 08-FLT2 and 09-FLT1).

<b>11-STAT</b> - Inverter Status Byte		L3
---------------------------------------	--	----

This parameter is accessible to determine the present conditions in which the inverter is operating. The data is stored as an integer, but represents a binary word. Bit #7, the most significant bit, when active indicates that the drive is operating within the 8PC limit of 04-TMAX. Bit #6, when active, indicates that the drive is operating in torque limit. When bit #5 is active, the drive is operating at an output frequency in excess of that programmed at parameter 36-F5. Bit #4 being active indicates that the drive is "AT SPEED".

The remaining bits (3 thru 0) combine to indicate multiple conditions as outlined in the following table:

BIT NUMBER				DESCRIPTION
3	2	1	0	
0	0	0	0	Power applied to the inverter and it is in IDLE, awaiting either an operation or programming instruction.
0	0	0	1	The inverter has faulted.
0	0	1	0	The inverter is in the STOP condition.
0	1	0	0	The FORWARD direction has been selected.
1	0	0	0	The REVERSE direction has been selected.
1	1	1	0	DC voltage is presently applied to the motor.
1	1	1	1	Writing this value into 11-STAT can be used to reset all faults.

**Parameter****Units****Level****21-MODE - Input Mode**

L1/L3

21-MODE defines the operating functions that are active from the Keypad, the Terminal Strip, and the SIO Serial Link in both the LOCal and REMote operating modes. Also the mode transfer mechanism is defined by your selection at this parameter. Proper setting of this parameter is the first step in customizing the inverter to your application. The following table defines the combinations available to the SIO user.

DATA CODE		LOCal (1)		REMote		LOC/REM Transfer via:	See Note
FWD only (2)	FWD/REV (2)	Speed (3)	Start/Stop	Speed (3)	Start/Stop		
<b>SIO Control Only</b>							
7	17	Disabled		24-FSEL	23-CNTL	N/A	
<b>Combination Keypad/SIO Control</b>							
6	16	Keypad		24-FSEL	23-CNTL	LOC/REM key	
26	36	Keypad		24-FSEL	23-CNTL	PS3	
<b>Combination Terminal Strip/SIO Control</b>							
8	18	24-FSEL	23-CNTL	Terminals		PS3	
<b>Combination Keypad/Terminal Strip/SIO Control</b>							
5	15	Keypad		25-FEXT1	Terminals	LOC/REM key	4
25	35	Keypad		25-FEXT1	Terminals	PS3	4

**Notes:**

1. Under LOCal operation, when control is specified as keypad, the active torque limit reference is the preset values at parameters 61 thru 64 as if parameter 27-TLSEL were set to a code "3". In all other cases, the drive obeys the setting of parameter 27 directly.
2. Enables or disables the REV key on the keypad.
3. When "Terminals" specified as a speed reference, the programming of parameter 24-FSEL actually controls the active speed reference.
4. In REM operation, terminals PS1, PS2, PS3 and ART are active. All will (except PS3 in modes greater than 20) perform their previously defined function (see Section 2.8).

**22-FNCT - Inverter Operating Function**

L3

This RAM parameter, represented by the integer values 0 thru 4, defines whether the inverter is expecting to receive a programming change or an operational command. The host computer either sets 22-FNCT to code "4" to enable a program parameter change, or code "3" to enable an operational command.

**Parameter****Units****Level****23-CNTL - Control Information Byte**

L3

This RAM parameter is the mechanism thru which actual SIO control of the inverter is achieved. It is represented by a binary word. The activation of each binary bit is read by the inverter as if the respective terminal were activated at the terminal strip. The breakdown is as follows:

<b>BIT #</b>	<b>FUNCTIONAL RESPONSE</b>
7	A reverse command is initiated as though the REV terminal is activated from the terminal strip.
6	A forward command is initiated as though the FWD terminal is activated from the terminal strip.
5	Once this command is initiated, either directional command will be maintained until the inverter is commanded to stop or change direction, just as if the R/J terminal were activated.
4	Activating this bit will put the inverter in a coast to stop mode.
3	Activating this bit is functionally the same as engaging the ART terminal.
2	Activating this bit is functionally the same as engaging terminal PS3.
1	Activating this bit is functionally the same as engaging terminal PS2.
0	Activating this bit is functionally the same as engaging terminal PS1.

**25-FEXT1 - External Speed #1**

Hz

L3

**26-FEXT2 - External Speed #2**

Both 25-FEXT1 and 26-FEXT2 are RAM parameters that allow the host computer to write real values for output frequency in storage registers. Parameter 24-FSEL then can be used to have the inverter to look at these values as the active speed reference. The range is 0.00 to 400 Hz.

**28-TLEXT - External Torque Limit Reference**

L3

Like 25-FEXT1 and 26-FEXT2, 28-TLEXT is a RAM parameter that works as a storage register. Real number values between 0 and 150% or drive rating can be stored here. Based on the value of 27-TLSEL, 28-TLEXT can become the active torque limit reference.

**29-COUT - Control Output Status**

L3

The binary word that is represented by this integer value can be used to deduce the status of the drive's digital outputs. Bits 5 thru 7 are not used and will always be "0". If bits 4 thru 0 are active, the representation is as follows:

<b>BIT #</b>	<b>FUNCTIONAL INDICATION</b>
4	Will indicate the activity of ST5, used only on option boards.
3	Will indicate the activity of STR, the auxiliary relay mounted on the control board.
2	Will indicate the activity of ST3, one of the open collector outputs on the control board, or the option card mounted relay following its active state.
1	Will indicate the activity of ST2, one of the open collector outputs on the control board, or the option card mounted relay following its active state.
0	Will indicate the activity of ST1, one of the open collector outputs on the control board, or the option card mounted relay following its active state.

**Parameter** **Units** **Level**

**7A-CIN** - Control Board Terminal Status

L3

**7B-CIN2** - Option Board Terminal Status

The binary word represented by this integer value can be used to determine the status of the input terminal function. Parameter 7A-CIN relates to the control board inputs, parameter 7B relates to the option board inputs. The functions detected by this parameter are represented as active bits according to the following:

BIT #	FUNCTIONAL INDICATION
7	Will indicate that Reverse is active.
6	Will indicate that Forward is active.
5	Will indicate that R/J is active.
4	Will indicate that CTS function is active.
3	Will indicate that the ART input is active.
2	Will indicate that terminal PS3 is active.
1	Will indicate that terminal PS2 is active.
0	Will indicate that terminal PS1 is active.

**7C-FIN** - Control Board Analog Input Status

L3

**7D-FAUX** - Option Board Analog Input Status

The integer value found at this parameter represents the real world value of the analog speed input at the control board (7C-FIN) or from the option board input (7D-FAUX). It translates to a number in the range of 0-32,767 for 0 to maximum input.

**7E-LIM** - Analog Torque Limit Input Status

L3

The integer value found at this parameter represents the real world value of the analog torque limit input at the control board. It translates to a number in the range of 0-15,000 for 0 to 150% of rated torque.

**91-SIOC** - SIO Communication BAUD Rate

L3

The integer value stored at this parameter determines the communication BAUD rate used between the inverter and the host computer. Also, communication rights may be selected as either read/write or read-only. Data codes "0" thru "3" provide both read and write capability. Codes "4" through "7" are read-only. The BAUD rates available are:

DATA CODE	BAUD Rate
0/4	9600
1/5	4800
2/6	2400
3/7	1200

**92-SIOA** - SIO Slave Address

L3

This parameter allows an individual slave address to be assigned to each slave inverter in a multi-drive application. Integer values between 1 and 94 are available.

**93-SIOT** - SIO Watchdog Timer

L3

This parameter is the storage location for a real number of seconds. With 93-SIOT set to a value greater than zero, SIO activity must be logged at least once in that timeframe. It is used to monitor communication integrity primarily.

**Parameter****Units****Level****94-SIOF - SIO Fault Byte**

L3

The integer value stored at this location may be decoded to a binary word to detect faults associated with SIO communication. When various bits become active, they represent various faults that are SIO communication related. The significant bits and their indication are as follows:

<b>BIT #</b>	<b>FUNCTIONAL INDICATION</b>
7	The value written in the last communication was outside the range of acceptable values.
6	The last communication was to a write protected parameter.
5	The last communication was to an unknown parameter.
1	The value in seconds programmed at 93-SIOT has been exceeded without a valid SIO communication.
0	The restart procedure of drive re-initialization is in process.

**95-SIOP - SIO Protocol**

L3

The integer value stored at this parameter defines the communication protocol, selecting various ISO1745 and OPTO22™ options. The selections are outlined as follows:

<b>DATA CODE</b>	<b>DESCRIPTION</b>
<b>0</b>	ISO1745 protocol with even parity and seven data bits.
<b>1</b>	ISO1745 protocol with no parity and seven data bits.
<b>2/3</b>	OPTO™ protocol with no parity and seven data bits

OPTO22™ is a trademark of OPTO 22, Huntington Beach, CA.

# SECTION 6

## APPLICATIONS

The following sections show various typical wiring connections of external controls to the WFC<sup>HT</sup> Series Inverter. Section 6.1 contains wiring diagrams for various speed control, torque control, start/stop and direction control, as well as options available from the inverter's terminal strip. Refer to Section 2.7 Function and Use of Terminals.

**WARNING**  
**TWIST WIRES TOGETHER BEFORE INSERTING IN TERMINAL.**

**ADVERTISSIMENT**  
**ENROULEZ LE FILS ENSEMBLE AVANT DE LES INTRODUIRE DANS LA BORNE.**

### 6.1 Connecting Diagrams

The following diagram shows typical connections for external speed and torque control as well as external starting and stopping of the inverter. Requirements for a jog feature and reversing are also included.

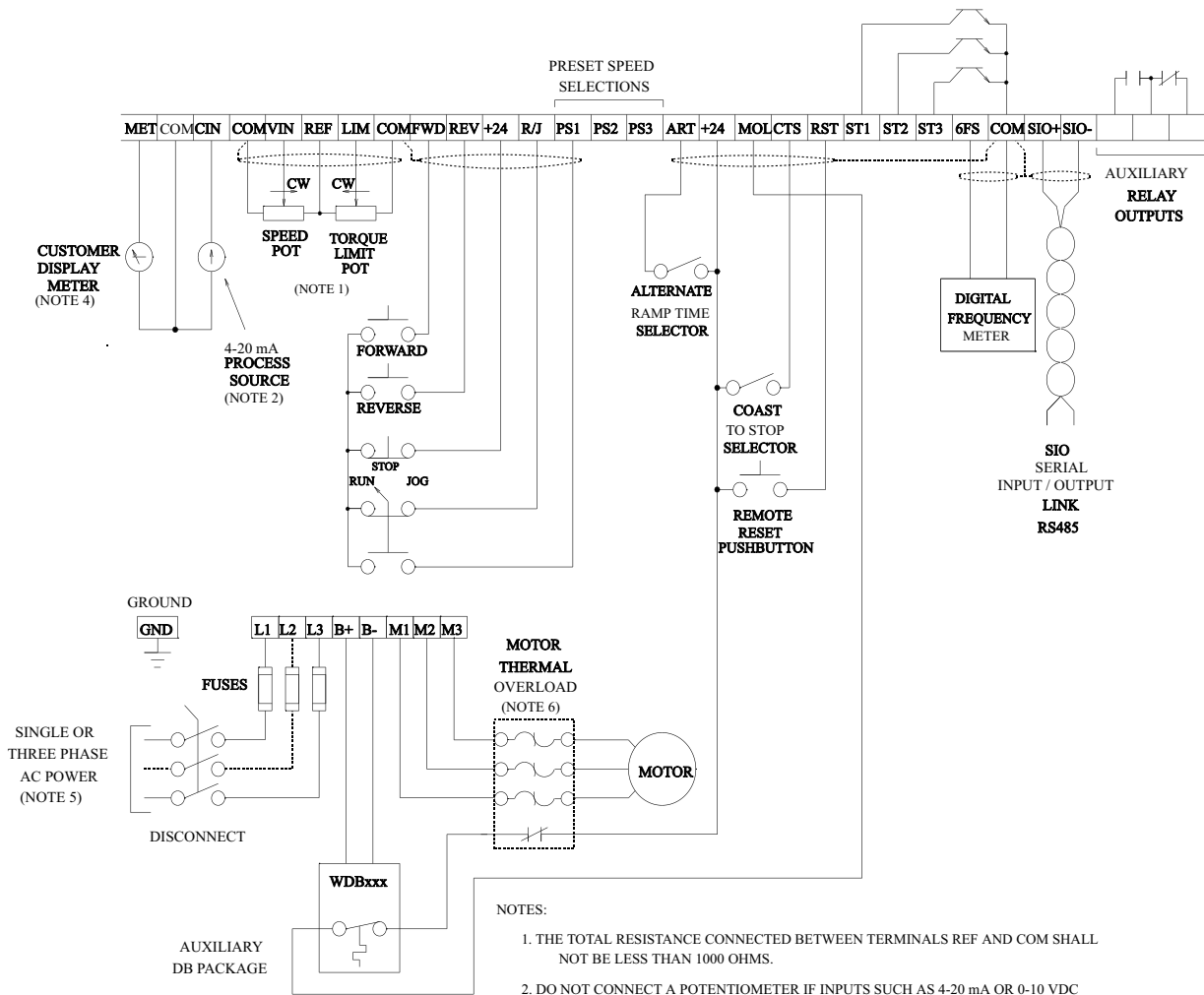

**NOTES:**

1. THE TOTAL RESISTANCE CONNECTED BETWEEN TERMINALS REF AND COM SHALL NOT BE LESS THAN 1000 OHMS.
2. DO NOT CONNECT A POTENTIOMETER IF INPUTS SUCH AS 4-20 mA OR 0-10 VDC ARE USED.
3. ALL CONTROL BOARD CONNECTIONS SHOULD USE TWISTED AND SHIELDED WIRE WITH THE SHIELD CONNECTED TO TERMINAL COM.
4. THE FACTORY SETTING FOR THE CUSTOMER METER IS 10 VDC FULL SCALE, INDICATING OUTPUT FREQUENCY. THE FULL SCALE OUTPUT MAY BE ADJUSTED USING PARAMETER 70-MCAL. SEE SECTION 4.11 FOR FURTHER INFORMATION.
5. THE USE OF SINGLE OR THREE PHASE POWER IS MODEL DEPENDENT. SEE SECTION 1.5 FOR FURTHER INFORMATION.
6. EXTERNAL OVERLOADS ARE OPTIONAL WHEN USING SINGLE MOTORS (SEE PARAMETER 67).



## 6.2 WFC<sup>HT</sup> Series Options

### WPC Plug-In Option Boards

WPC Plug-In Option Boards are specifically designed to work with WFC<sup>HT</sup> Series AC Inverters. They install inside any WFC model inverter above the control board in the J7 option connector.

#### WPC01 – Isolated Output Board

The WPC01 Isolated Output Board has two functions. One section is used to convert the three open collector transistor outputs (ST1, ST2 & ST3) to Form C contacts rated 115 VAC @ 1 Amp for customer use. Each relay can be individually programmed to indicate one of eleven (11) inverter states. The other section provides two isolated, 4-20 mA output signals for customer use. One output varies proportionally to output load, and the other is programmable to follow either frequency, volts, current, load or torque.

#### WPC02 – 115 Volt Input Interface Board

This option card is used to allow the inverter to be controlled by 115 VAC signals instead of the normal +24 VDC logic. It provides isolated control of FWD, REV, R/J, PS1, PS2, PS3, ART, MOL, CTS and RST. Additionally, two relays are provided with one Form C contact each rated 115 VAC @ 1 Amp. These are controlled by the settings of ST1 and ST3. A Triac output is also supplied which is controlled by the setting of ST2.

#### WPC03 – Relay/Line Transfer Board

This option board provides three relays to convert the three open collector transistor outputs (ST1, ST2, & ST3) to Form C contacts rated at 115 VAC @ 1 Amp for customer use. It also allows for synchronous transfer of a motor from inverter power to AC line power and back when used with external contractors (not supplied).

#### WPC04 – Encoder Interface Board

The WPC04 option allows the user to interface the WFC<sup>HT</sup> or WFC Series Inverter to a shaft mounted encoder or magnetic pickup. It permits such advanced control functions as: Closed loop speed control, Master/Follower operation, and Event counting.

#### WPC05 – Process Control Board

The WPC05 board adds two additional functions to the WFC<sup>HT</sup> or WFC Series Inverters: a bi-polar speed reference input with trim and an interface with process signals for speed regulation. The bi-polar speed reference allows a  $\pm 10$  VDC signal or potentiometer to be used to control both the speed *and* direction of the motor. The process control function permits set-point with proportional and integral gain adjustment, of pumps, fans, winders, etc., using standard analog feedback signals.

#### WPC06 – Logic Interface Board

This option board has similar features and functions as WPC02 – 115 VOLT Input Interface Board but is scaled for use with 24 volts AC or DC control signals. It also permits the WFC<sup>HT</sup> to be controlled by open collector “pull-down” transistor circuits if required. The Triac output used on the WPC02 is not provided.

#### WKM01 – Keypad Mounting Kit

The WKM01 option is intended for use when the standard WFC<sup>HT</sup> is mounted inside another enclosure and it is desired to have the standard keypad remotely mounted on that enclosure. It allows the keypad to be remotely mounted from the control. The kit includes a mounting bezel, instructions, a 10 foot cable for installation, and a terminal “fan-out” strip. When used with WBP01 (see below), the keypad can be mounted more than 100 feet from the control. If properly installed, the keypad will retain its NEMA 4 rating.

#### WKM02 – Keypad Remote Control Kit

The WKM02 option is intended for use when it is desired to have the standard keypad remotely mounted from the NEMA 4 WFC<sup>HT</sup> unit. It allows the keypad to be mounted in its own enclosure up to 100 feet from the control. The kit includes the mounting enclosure (5.35" x 6.78" x 2.5" HxWxD), keypad connector fan-out board, WBP01 Keypad Blank Plate Option and instructions for installation. When properly installed, the keypad and unit will retain their NEMA 4 ratings.

#### WBP01 – Keypad Blank Plate Option

This option is used to replace the digital keypad in NEMA 4 models when the keypad has been remotely mounted. When properly installed, the WFC<sup>HT</sup> will retain its NEMA 4 rating.

#### WDB211/WDB411 – External Dynamic Brake Assembly

The WDBxxx assemblies are designed to increase the capacity of the WFC<sup>HT</sup> to absorb the regenerated energy from a motor during rapid deceleration or overhauling loads. The WDB211 is designed to connect to any 230 Volt WFC<sup>HT</sup> Inverter and provide 10 horsepower of braking capacity at a 10% duty cycle. Similarly, the WDB411 is intended for use on 460 volt models. For capacities greater than 10 horsepower, units can be connected in parallel.

### **WCK-01/02/03/04 – Chassis Mounting Kits**

This option allows the WFC<sup>HT</sup> Series Inverter to be mounted with the heat sink fins protruding through the back of another enclosure. This mounting scheme allows the cabinet size to be minimized since most of the energy dissipated by the inverter will be channeled through the fins to the outside of the cabinet. Gasketing is supplied to allow the package to maintain its environmental integrity. The WCK01 Chassis Mounting Kit fits all models through 5 HP; the WCK02 fits 460 VAC models from 7.5 through 20 HP and 230 VAC models 7-1/2 and 10 HP. WCK03 is used for the 20 HP 230 VAC and 25-30 HP 460 VAC models. WCK04 is used for the 25 HP 230 VAC and 40-75 HP 460 VAC models.

### **SI0C01 – Serial Interface Converter**

This is a stand-alone converter module which will translate the RS232 communications protocol used in many personal computers to the industrial RS485 protocol used in the WFC<sup>HT</sup> Series Inverter.

## **6.3 Application Hints**

A number of typical applications have proven to require further explanation. Several typical applications are summarized in the following paragraphs.

### **Use of Motor Starters with the WFC<sup>HT</sup>**

A frequent application of inverters is in previously fixed speed, uni-directional applications where the motors are controlled by electromagnetic starters. The WFC<sup>HT</sup> Series is compatible with this kind of operation, providing the start/stop cycle time does not exceed 30 times per hour (1 start/2 minutes).

Connect the contactor on the line side of the inverter. Set parameter 21-MODE for terminal run/stop control and install a wire jumper or maintained contact between Terminals FWD & +24. Finally, set parameter 82-START to a data code that defeats the standard line start lockout feature.

If the contactor must be installed on the inverter's output to conform with local electrical codes or some other compelling reason, it must be interlocked to the WFC<sup>HT</sup> to shut it down when the starter opens for any reason. This can be accomplished by connecting a normally closed auxiliary of the motor starter to Terminals CTS & +24 on the WFC<sup>HT</sup>. When the contactor opens, the auxiliary will close forcing the inverter to turn off without a deceleration ramp. NOTE: IF TRIPS OCCUR, A SPECIAL SNUBBER NETWORK MAY NEED TO BE INSTALLED ACROSS THE CONTACTS; CONSULT THE FACTORY.

### **Defeating the Keypad**

The inverter's standard keypad is designed to give full functional control for most applications. This may be prohibitive in some cases. If a remote station is to have exclusive control of speed and direction commands, set 21-MODE to code 4 or 14. The keypad stop key will remain active as both an EMERGENCY STOP button and a fault RESET mechanism. To defeat the E-STOP function, set parameter 82-START to a value greater than 3, being careful to observe the other ramifications of the selection (ability to start a rotating motor & line start lockout).

An access code may be assigned to prohibit unauthorized program revision. See parameter 87-ACODE for more information.

Finally, if absolutely necessary, the entire keypad may be removed for total isolation of the control. Install a WBP01 in place of the keypad on enclosed models to maintain the NEMA 4 integrity.

### **Master/Slave Control of Multiple Inverters with Ratio Adjust**

A series of master and slave controls is quite common in industrial processes. Most are uni-directional applications. Frequently, it is necessary that they not all run at exactly the same speed. With the WFC<sup>HT</sup> Series, this kind of control is possible even while maintaining the use of one standard keypad for system control. This scheme requires control reprogramming to reset the speed ratio of the followers, however.

To accomplish full system control from the master's keypad, the following program changes must be made:

**Master** – 75-STR = 5    88-FRO = 0    **Slave(s)** – 21-MODE = 4    24-FSEL = 3    75-STR = 1

Parameter A2-RATIO on each drive will be used to set the speed ratio of each follower to the master's speed.

To get the speed to follow each other in a ratio sequence, connect Terminal 6FS on the master to each of the follower's VIN terminals and Terminal COM on all the drives together. To achieve common direction command, connect the FWD terminals on all slaves together with the normally open auxiliary relay on the master and connect the common connection of the master's auxiliary relay to its Terminal +24.

To achieve fault interlocking for all the drives, connect the normally closed auxiliary relay contacts on all the follower drives in series back to Terminals +24 and MOL on the master. This will cause the fault on any slave to shut down the master and the entire system.

### **Conclusion**

Refer to the individual programming parameters listed throughout the manual to define the impact of each program change. An Electrical Applications Engineer is available to discuss these applications or your particular needs daily. See the contact information on the back of the manual.

## SECTION 7

### TROUBLESHOOTING

#### WARNING

DISCONNECT POWER BEFORE SERVICING THIS CONTROL.  
HAZARDOUS VOLTAGES EXIST UNTIL CHARGE LIGHT GOES OUT.

#### AVERTISSEMENT

COUPER L'ALIMENTATION AVANT D'ENRERENORE LE DEPANNAGE DU SYSTEME ELECTRIQUE.  
VOLTAGE DANGEUREUX EXISTE TANT QUE LA LUMIERE INDICATRICE RESTE ALLUMÉ.

#### 7.1 Fault Codes

NUMBER	MESSAGE	EXPLANATION
F01	COMPUTER ERROR	CPU Malfunction
F02	MEMORY ERROR	EEPROM Data Destroyed
F03	CURR SENSE ERROR	Wrong Bus Current Measurement
F04	PWR SUPPLY ERROR	Power Supply Voltage Low
F05	NO DC BUS VOLTS	Low DC Bus Voltage Detected
F06	OUTPUT SHORT CKT	Short Sensed During Power-up
F07	MOL CONTACT OPEN	Motor Overload Terminal Fault
F08	OPTION BD FAULT	Error in an Option Card
F10	RESTART LOCKOUT	Auto Restart Number Exceeded
F11	GROUND FAULT	Ground Fault Detected
F12	EXT INTERFERENCE	External Interference
F13	OVERVOLTAGE	DC Bus Voltage Too High
F14	UNDERVOLTAGE	DC Bus Voltage Too Low
F15	DYN BRAKE OVLD	DB Duty Cycle above Limits
F16	ACCEL OVERCURRE	Overcurrent During Acceleration
F17	DECEL OVERCURRE	Overcurrent During Deceleration
F18	RUN OVERCURRENT	Overcurrent While at Speed
F19	OVERTEMP TRIP	Heat sink Temperature Too High
F20	TIMED OVERLOAD	Electronic Overload Exceeded

TABLE 7.1

#### NOTES:

1. Faults **F01-F08** are checked during the power-up sequence.
  - F02 is also checked during the programming.
  - F04 is also checked in the run and stop modes.
2. Faults **F11-F20** will be reset and the inverter restarted if the Auto-Restart function is selected.

## 7.2 Troubleshooting

FAULT NUMBER	CAUSE	REMEDY
F01	Noise on Power Line	<ol style="list-style-type: none"> <li>1. Reset the drive using the stop key or remote reset.</li> <li>2. Remove power, wait for the BUS CHG indicator to extinguish and re-establish power.</li> <li>3. If the problem persists, install a line noise filter.</li> </ol>
F02	Excessive Ambient Electrical Noise or an Invalid 59-MVOLT Setting	<ol style="list-style-type: none"> <li>1. Verify the proper use of shielded wire for remote signal connections.</li> <li>2. Remove power, wait for the BUS CHG indicator to extinguish and re-establish power.</li> <li>3. Verify the setting of 59-MVOLT and reset to a valid number.</li> </ol>
F03	Excessive DC Bus Current	<ol style="list-style-type: none"> <li>1. Verify the proper sizing of the inverter for the driven load.</li> <li>2. Determine the reason for the overload.</li> </ol>
F04	Logic Power Supply Overload	<ol style="list-style-type: none"> <li>1. Check for/reduce excessive load on the +24 VDC supply.</li> <li>2. Remove power 10-15 min.; then reapply.</li> </ol>
F05	No DC Bus Voltage	<ol style="list-style-type: none"> <li>1. Check for proper source voltage.</li> <li>2. Check for DB component or output transistor failure.</li> <li>3. Check for shorted DC bus.</li> <li>4. Remove power 10-15 min.; then reapply.</li> </ol>
F06	Output Short Circuit or Ground Fault	<ol style="list-style-type: none"> <li>1. Check motor wiring.</li> <li>2. Extend the acceleration time.</li> <li>3. Reduce 52-BOOST value.</li> <li>4. Increase 53-FKNEE value.</li> <li>5. Isolate line and load wires.</li> <li>6. Consult factory.</li> </ol>
F07	External Fault Mechanism (i.e. Motor Overload Relay [MOL] Tripped)	<ol style="list-style-type: none"> <li>1. Check connections on MOL terminal.</li> <li>2. Verify the sizing of MOL.</li> <li>3. Check motor temperature.</li> </ol>
F08	Option Board Fault	<ol style="list-style-type: none"> <li>1. Verify the proper connection and usage of applicable option board.</li> </ol>
F10	Auto-Restart (68-NRST) Number Exceeded	<ol style="list-style-type: none"> <li>1. Check the fault log (07-FLT3, 08-FLT2, and 09-FLT1).</li> <li>2. Institute corrective action for those faults.</li> </ol>
F11	Ground Fault	<ol style="list-style-type: none"> <li>1. Check motor wiring.</li> <li>2. Extend the acceleration time.</li> <li>3. Check for and remove any capacitive load.</li> <li>4. Reduce 52-BOOST value.</li> <li>5. Increase 53-FKNEE.</li> <li>6. Isolate line and load wires.</li> <li>7. Check for output contactor. (See Section 6.3.)</li> </ol>
F12	External Interference	<ol style="list-style-type: none"> <li>1. Verify line voltage.</li> <li>2. Look for electrical noise sources in proximity to the drive. (See Section 2.6.)</li> <li>3. Install line reactor or isolation transformer.</li> <li>4. Consult factory.</li> </ol>
F13	Overvoltage on DC Bus	<ol style="list-style-type: none"> <li>1. Motor is decelerating too quickly.</li> <li>2. Check input line voltage.</li> <li>3. Increase deceleration time or add optional external DB package.</li> </ol>
F14	Undervoltage on DC Bus	<ol style="list-style-type: none"> <li>1. Verify applied line voltage.</li> <li>2. Check for possible DB failure.</li> </ol>
F15	DB Overload	<ol style="list-style-type: none"> <li>1. Reduce the braking duty cycle.</li> <li>2. Verify line voltage.</li> <li>3. Install optional external DB package.</li> </ol>
F16	Acceleration Overcurrent	<ol style="list-style-type: none"> <li>1. Increase acceleration ramp time.</li> <li>2. Check motor wiring for short circuit.</li> </ol>
F17	Deceleration Overcurrent	<ol style="list-style-type: none"> <li>1. Increase deceleration ramp time.</li> <li>2. Install optional external DB package.</li> </ol>

TABLE 7.2 (continued on next page)

## 7.2 Troubleshooting (continued)

FAULT NUMBER	CAUSE	REMEDY
<b>F18</b>	Running Overcurrent	1. Locate the cause of a mechanical overload on the motor.
<b>F19</b>	Heat Sink Overtemperature	1. Check for excessive load on the motor. 2. Verify the proper sizing of the WFC <sup>HT</sup> for the application. 3. Locate the WFC <sup>HT</sup> in a cooler location, out of direct sunlight.
<b>F20</b>	Timed Overload	1. Check for WFC <sup>HT</sup> sizing for the application. 2. Reduce the loading on the motor. 3. Check for DB component or output transistor failure. 4. Check for shorted DC bus. 5. Check setting of 67-TOL.

PROBLEM	CHECK POINT	CORRECTIVE ACTION
<b>Motor is not running</b>	Incorrect wiring	1. Check all power and control wiring.
	External frequency command (if used)	1. Verify that the external frequency control signal is properly connected. 2. Verify the integrity of the frequency control potentiometer (if used).
	Programming selections	1. Verify that the proper programming selections have been made for the application.
	Fault	1. Verify that the inverter has not shut down due to a fault condition. 2. Consult Table 8.2.
	Motor stall	1. Release any overload on the motor. 2. Verify that adequate torque boost is available.
<b>Motor Speed Fluctuation</b>	Loose terminal connection	1. Stop the inverter, turn off power, and tighten all terminal screws. 2. Check for tightness of all connections within the drive.
	Frequency control pot erratic	1. Replace frequency control potentiometer.
<b>Motor Speed Too High or Too Low</b>	Frequency profile	1. Verify that the setting of 53-FKNEE and 32-FMAX are correct for the motor specification and application.
	Frequency control signal	1. Verify the input signal level.
	Motor nameplate specifications	1. Verify that the motor selection is proper for the application.
<b>Display Blank</b>	Keypad connections intermittent	1. Verify keypad connections to control board.
	Logic supply overload	1. Check for excessive load on terminal +24. 2. Remove power for 10-15 minutes; then reapply.

TABLE 7.3

## 7.3 Maintenance and Inspection

The WFC<sup>HT</sup> AC Inverter is essentially maintenance-free and should provide years of trouble-free operation if proper installation and operation procedures are observed. Chassis type controls are designed to be operated in relatively clean and low humidity areas. If dust accumulates on the internal printed circuit boards and components, remove power and clean with low pressure air or vacuum. Remove any dust or lint that accumulates on the outside of the enclosure, the fan, the fan grille, and the heat sink fins to maintain the excellent cooling properties of your WFC<sup>HT</sup> Inverter. NEMA 4 models are by design compatible with being washed down by water. After this has been done, it is suggested that the drive be operated for several minutes to expel any water trapped within the fan motor.

## 7.4 Replacement Parts

The tables on the following pages reflect those replacement parts compatible with WFC<sup>HT</sup> Series AC Inverters.

### WFC<sup>HT</sup>1000 & WFC<sup>HT</sup>2000 Series Replacement Parts

Description	Part Number	1001-0	2000-7	2001-0	2002-0	2003-0	2005-0	2007-5	2010-0	2015-0	2020-0	2025-0
Control Board	PC505	1	1	1	1	1	1	1	1	1	1	1
Keypad	PC233	1	1	1	1	1	1	1	1	1	1	1
Power Card	PC387	1										
	PC388		1									
	PC389			1								
	PC390				1							
	PC391					1						
	PC392						1					
	PC394							1	1			
	PC395									1		
	PC396										1	
	PC397											1
Power Int. Board	PC448							1				
	PC449								1			
Aux. Power Card	PC450								1	1	1	
Snubber Card	PC464									1	1	1
Fan Kit	FANKIT5HP				1	1	1					
	INTFANKIT20HP							1	1			
	EXTFANKIT20HP							2	2			
	INTFANKIT50HP									1	1	1
	EXTFANKIT50HP									3	3	3
DB Kit	DB2005	1	1	1	1	1	1					
	DB2010							1	1			
Cover Kit	COVERKIT5HPHT	1	1	1	1	1	1					
	COVERKIT20HPHT							1	1			
Cur. Sense Asbly.	U6200R									1	1	1
MOV Board	PC165							1	1			
	PC187									1	1	1
Capacitor Board	PC154							1				
	PC155								1			
Output Module	U8578CR								3			
	U8579CR							3				
	U8586CR									3		
	U8587CR										3	
	U8588CR											3
Relay	U6519R							1	1			
	U6516R									1	1	1
Rectifier Module	E56205R							1				
	E56206R								1			
	E56208R									3	3	
	E56209R											3
Power Supply Modules	PSMOD07	1	1	1	1	1	1					
	PSMOD08									1	1	1
	PSMOD09							1	1	1	1	1

**WFC<sup>HT</sup>4000 Series Replacement Parts**

Description	Part Number	4001-0	4002-0	4003-0	4005-0	4007-5	4010-0	4015-0	4020-0	4025-0	4030-0	4040-0	4050-0	4060-0	4075-0
Control Board	PC505	1	1	1	1	1	1	1	1	1	1	1	1	1	1
Keypad	PC233	1	1	1	1	1	1	1	1	1	1	1	1	1	1
Power Card	PC398	1													
	PC399		1												
	PC400			1											
	PC401				1										
	PC402					1									
	PC403						1								
	PC404							1							
	PC406								1						
	PC407									1					
	PC408										1				
	PC409											1			
	PC410												1		
	PC412													1	
	PC413														1
Aux. Power Card	PC415									1	1	1	1	1	1
Snubber Card	PC464									1	1	1	1		
	PC261													1	1
Fan Kit	FANKIT5HP			1	1										
	INTFANKIT20HP					1	1	1	1						
	EXTFANKIT20HP					2	2	2	2						
	INTFANKIT50HP									1	1	1	1	1	1
	EXTFANKIT50HP									3	3	3	3		
	EXTFANKIT75HP													1	1
DB Kit	DB4005	1	1	1	1										
	DB4020					1	1	1	1						
Cover Kit	COVERKIT5HP	1	1	1	1										
	COVERKIT20HP					1	1	1	1						
MOV Board	PC166					1	1	1	1						
	PC188									1	1	1	1		
Cur. Sense Asmby.	U6200R									1	1	1	1		
	U6199R													1	1
Capacitor Board	PC156					1		1							
	PC157						1		1						
	PC158							1							
	PC164								1						
Output Module	U8591CR						3	3							
	U8577CR					3									
	U8583CR									3	3				
	U8584CR											3			
	U8585CR												3		
	U8589CR													3	3
	U8593CR								3						
Relay	U6513R					1	1								
	U6519R							1	1						
	U6516R									1	1	1	1		
	U6528R													1	1
Rectifier Module	E56204R					1	1	1		1					
	E56207R								1						
	E56210R									3					
	E56211R										3	3			
	E56212R												3	3	3
Voltage Share Bd.	PC219									1	1	1	1	1	1
Power Intfc. Bd.	PC436					1									
	PC437						1								
	PC438							1							
	PC439								1						
Power Supply Mod.	PSMOD04	1	1	1	1										
	PSMOD05					1	1								
	PSMOD06							1	1	1	1	1	1	1	1
	PSMOD08									1	1	1	1	1	1
ES Board	PC260												1	1	

## SECTION 8

### APPENDIX A

#### 8.1 Additional Publications

Form HSC-7, Fundamentals of AC Inverters, may be purchased from TB Wood's Incorporated at a nominal charge. This publication is a home study course which not only covers the fundamentals of AC inverters and AC motors, but also can be used as an application guide in sizing the correct AC inverter and AC motor for typical applications.

Form 997 **SIO Serial Link Protocol** is available free of charge. This publication elaborates on the software and hardware requirements necessary to communicate with the inverter via the SIO link.

Form 1041, EMOP and 5-speed operation manual for use in the crane and hoist industry.

Form 1042, Reference Signal Reversing, describes the features and programming for Bi-directional inverter operation with a uni-polar reference signal. (Parameter 81-PRGNO = 200 or 201)

#### 8.2 Hassle Free Warranty

The driving force at TB Wood's is customer service, including dealing with unforeseen problems without creating new ones! TB Wood's takes the extra step to ensure that ANY problem that occurs to its electronic products is dealt with swiftly and with no hassles to you. The Hassle Free Warranty removes the "burden of guilt" and promises to quickly replace any failed product.

**TB Wood's Incorporated warrants its electronic controls to be free of defects in parts or workmanship for a period of two (2) years from the date of manufacture. If a TB Wood's product fails for any reason, excluding physical abuse or repeated failure, within the warranty period, TB Wood's will promptly replace the product. TB Wood's Incorporated shall not in any event be liable for any incidental or consequential damages, secondary charges, expenses for installing or disconnecting, or losses to persons or property resulting from any failure of the product.**

## APPENDIX B

### Use of TB Wood's WLF Series Line Filters

## SECTION 1

### INTRODUCTION

This Appendix documents the specifications for TB Wood's WLF Series line filters. The Appendix also contains installation and usage information relative to these products.

Proper installation of these filters with the correct model of E-trAC® WFC<sup>HT</sup> Series inverter or XFC Series micro-inverter will aid in complying with CE (Conformite Europeen) EMC directives. These filters will limit emissions, per EMC Directive 89/336 EEC, to meet the following specifications:

#### EMA (Electromagnetic emission)

EN 50081-1	Basic specification, "Emitted Interference"
EN 55011	Emitted Interference - Industrial, Scientific and Medical Installations
EN 55014	Emitted Interference - Residential Installations

#### EMB (Electromagnetic interference)

EN 50082-2	Basic specification, "Interference Immunity"
EN 50140	Electromagnetic Fields
EN 60801	Static Discharge
ENV 50142	Surge
IEC 801-4	Burst on mains lead/data line

#### To assure compliance with the EMC directive, the following procedures must be observed:

- Installation of a line filter with properly matched WFC<sup>HT</sup> inverter.
- To meet the B Emission Curve for EMC (Commercial) Compliance, an output reactor may also be required. No output filter or reactor is required to meet the A Emission Curve for EMC (Industrial) Compliance (reduces leakage current to a level below 3.5 mA).
- Installing shielded motor cable and correctly grounding the shield.
- Observe general RFI suppression measures (refer to Section 5 – Interference suppression measures/EMC [Electromagnetic Compatibility]).

Note that the WLF series of line filters does not bear the CE mark. Although the filters have been tested with the inverters for compliance, installation practices and other wiring concerns make CE compliance with EMC directives the responsibility of the installer of the equipment.

In addition, motor output wiring considerations required to meet the CE directives are also presented.

Similarly, the WLF series of line filters is not UL listed or recognized. If local codes permit, the filters may be used in the United States as a solution for EMI and RFI problems either caused by or effecting the operation of an E-trAC® series inverter.

## SECTION 2

### SPECIFICATIONS

TB Wood's WLF line filters are provided in both IP20 and IP54 type enclosures. They can operate over a temperature range of -10 to +50°C (-23 to +122°F). The mounting options for the filters can be parallel or perpendicular to the control panel. For some filter / inverter combinations, it is possible to mount the inverter on top of the filter enclosure. Details of the WFC inverter line compatibility can be found in the table below:

#### WFC<sup>HT</sup> Series Inverter Compatibility Chart

Inverter Model <sup>1</sup>	Input Phase	WLF Model Number		Voltage	Amps	HP	kW	Leakage	Stacked Mounting <sup>2</sup>
		IP20	IP54						
WFC20007x	1	<i>Consult Factory</i>	<i>Consult Factory</i>			0.75	0.5	5 mA	Y
WFC20010x	1	<i>Consult Factory</i>	<i>Consult Factory</i>			0.75	0.5	5 mA	Y
WFC20020x	1	<i>Consult Factory</i>	<i>Consult Factory</i>			1.5	1.1	5 mA	Y
WFC20030x	1	<i>Consult Factory</i>	<i>Consult Factory</i>			3.0	2.2	5 mA	Y
	3	WLF40050H	WLF40050D	460	12	5.0	3.7	5 mA	Y
WFC20050x	1	<i>Consult Factory</i>	<i>Consult Factory</i>			3.0	2.2	5 mA	Y
	3	WLF40200H	WLF40200D	460	38	20	15	5 mA	N
WFC20075x	3	WLF40200H	WLF40200D	460	38	20	15	5 mA	Y
WFC20100x	3	WLF40200H	WLF40200D	460	38	20	15	5 mA	Y
WFC20150x	3	WLF40300H		460	60	30	22	5 mA	N
WFC20200x	3	WLF40300H		460	60	30	22	5 mA	N
WFC20250x	3	WLF40400H		460	80	40	30	5 mA	N
WFC40010x	3	WLF40050H	WLF40050D	460	3	1.0	0.7	5 mA	Y
WFC40020x	3	WLF40050H	WLF40050D	460	5	2.0	1.5	5 mA	Y
WFC40030x	3	WLF40050H	WLF40050D	460	12	5.0	3.7	5 mA	Y
WFC40050x	3	WLF40050H	WLF40050D	460	12	5.0	3.7	5 mA	Y
WFC40075x	3	WLF40200H	WLF40200D	460	38	20	15	5 mA	Y
WFC40100x	3	WLF40200H	WLF40200D	460	38	20	15	5 mA	Y
WFC40150x	3	WLF40200H	WLF40200D	460	38	20	15	5 mA	Y
WFC40200x	3	WLF40200H	WLF40200D	460	38	20	15	5 mA	Y
WFC40250x	3	WLF40300H		460	60	30	22	5 mA	N
WFC40300x	3	WLF40300H		460	60	30	22	5 mA	N
WFC40400x	3	WLF40400H		460	80	40	30	5 mA	N
WFC40500x	3	WLF40500H		460	100	50	37	5 mA	N
WFC40600x	3	WLF40600H		460	120	60	45	5 mA	N
WFC40750x	3	WLF40750H		460	150	75	55	5 mA	N

- Notes: 1. x Denotes enclosure type: A = Chassis, B = NEMA 1, C = NEMA 4  
 2. Y = Can be mounted between the inverter and panel (See Section 3).  
 N = Must be mounted inside an enclosure.

# SECTION 3

## INSTALLATION

Upon receipt of the filter, unpack it and carefully inspect for any damage sustained in transit. If damage is apparent, the freight or express agent should be notified within 15 days of receipt of the product and a request be made that he make inspection of the merchandise; then a claim should be filed against the carrier. For UPS shipment damage, save the box and packing material and contact TB Wood's Incorporated immediately.

TB Wood's WLF Series line filters are designed to mount directly to a flat surface such as an enclosure panel. Metal hardware should be used to assure that the case of the filter is at earth ground potential. The filters can be mounted parallel to the panel or perpendicular to the panel.

The filter should be installed as close as possible to the inverter. When mounting the filters parallel to the panel, the inverter can be mounted to the top of the filter module with the hardware provided (see figure 1).

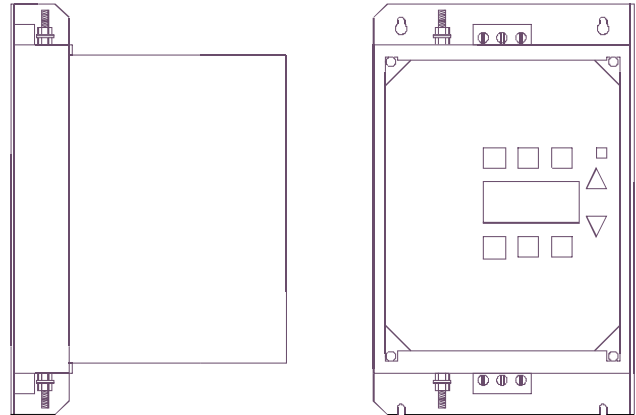

Figure 1

### Dimensions (IP20 versions to 20HP)

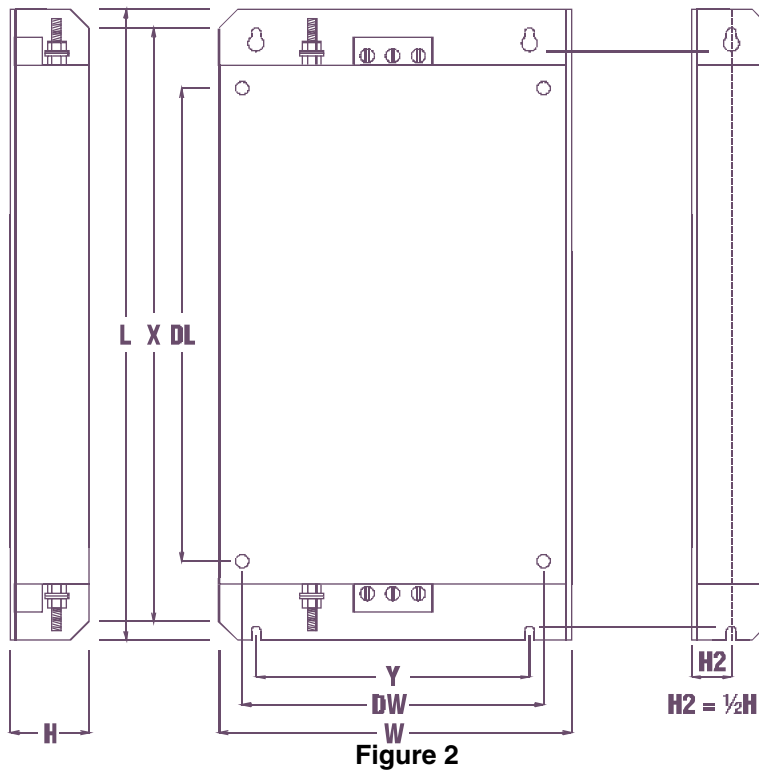
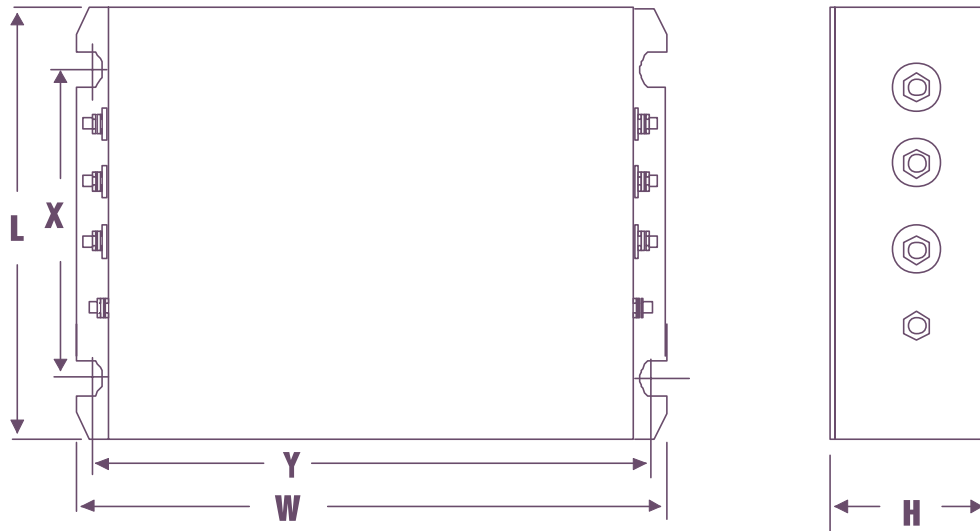

Figure 2

Model	Case Dimensions			Case Mounting			Drive Mounting			Terminals	
	L	W	H	X	Y	Size	DL	DW	Size	Lines	GND
WLF40050H	14.17/360	8.74/222	1.97/50	13.46/342	6.30/160	M6	11.02/280	7.87/200	M6	AWG 6	M5
WLF40200H	19.69/498	9.13/232	1.97/50	18.82/487	7.09/180	M6	16.50/419	7.87/200	M6	AWG 6	M5

- Notes: 1. Dimensions in inches/millimeters  
2. Terminal Labeled GND is at earth potential (PE)

**IP20 versions - 25 to 75HP**



**Figure 3**

Model	Case Dimensions			Case Mounting			Terminals	
	L	W	H	X	Y	Size	Lines	GND
WLF40300H	5.51/140	10.63/270	3.54/90	4.17/106	10.16/258	M6	AWG 6 (90°C) <sup>2</sup>	M5
WLF40400H	7.09/180	13.78/350	3.54/90	5.75/146	13.31/338	M6	M10	M10
WLF40500H	7.09/180	13.78/350	3.54/90	5.75/146	13.31/338	M6	M10	M10
WLF40600H	7.87/200	16.54/420	5.12/130	6.54/166	16.06/408	M6	M10	M10
WLF40750H	7.87/200	16.54/420	5.12/130	6.54/166	16.06/408	M6	M10	M10

**IP20 versions - 25 to 75HP**

- Notes:
1. Dimensions in inches/millimeters
  2. On the WLF40300H filter, the power conductor terminations are of a terminal block type rather than a stud type. For this filter, AWG 6 wire should be used. The wire must be rated for 90°C operation.

IP54 versions - up to 20HP

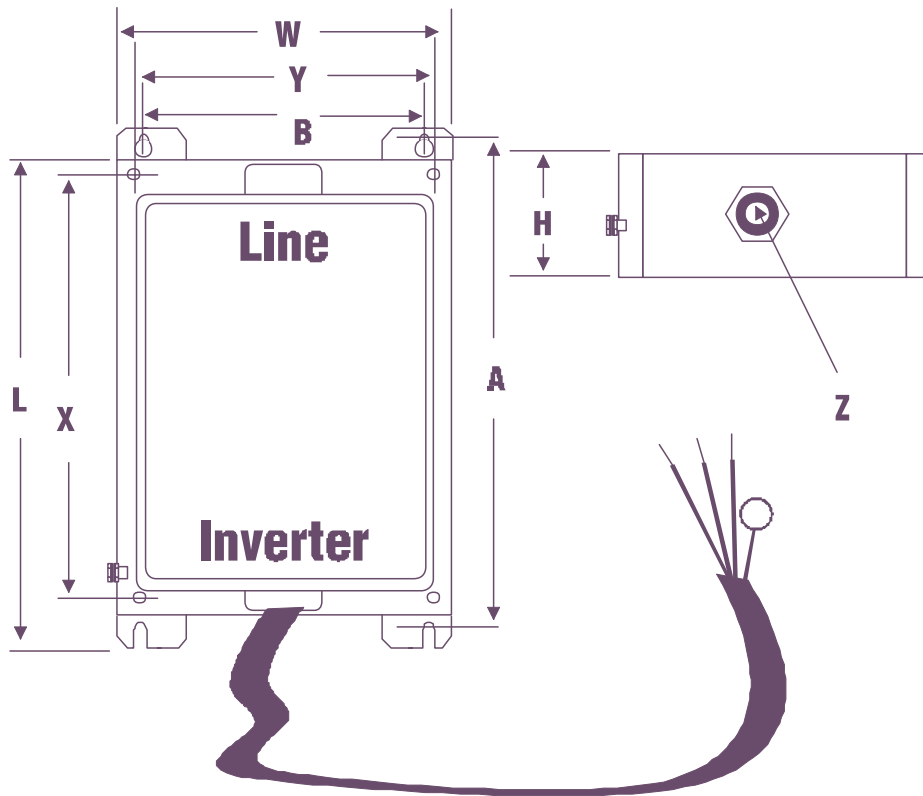

Figure 4

Model	Case Dimensions			Case Mounting			Drive Mounting			Terminals	
	L	W	H	A	B	Size	X	Y	Size	Lines	GND
WLF40050D	14.17/360	9.17/233	4.09/104	13.54/ 344	7.09/ 180	Key-slot (top): 0.71/18/high 0.51/13/large diam. 0.26/6.5/small diam.  Slot (bottom): 1.04/26.5/depth 0.26/6.5/width 0.43/11/diam. of curve	11.02/ 280	7.87/ 200	M6	AWG 6	M8
WLF40200D	19.45/494	9.17/233	4.09/104	18.82/ 478	7.09/ 180	Key-slot (top): 0.71/18/high 0.51/13/large diam. 0.26/6.5/small diam.  Slot (bottom): 1.04/26.5/depth 0.26/6.5/width 0.43/11/diam. of curve	16.54/ 420	7.87/ 200	M6	AWG 6	M8

- Notes: 1. Dimensions - inches / millimeters  
 2. The IP54 filters have a terminal block for line termination. Use the indicated wire size. The filter is connected to the inverter via the captive filter output cable. Connect the leads to the inverter's L1, L2, and L3 terminals. Connect the ground lead to the inverter ground.

# SECTION 4

## CONNECTIONS

### Wire Sizing Requirements

Model	Line Conductor	Ground Conductor Single Conductor	Ground Conductor 2 Parallel Conductors
WLF40050H	14 AWG, 600 V	6 AWG, 600 V	14 AWG, 600 V
WLF40050D			
WLF40200H	6 AWG, 600 V	6 AWG, 600 V	N/A
WLF40200D			
WLF40300H	6 AWG, 600 V (90°C wire)	6 AWG, 600 V (90°C wire)	N/A
WLF40400H	2 AWG, 600 V	2 AWG, 600 V	N/A
WLF40500H	1/0 AWG, 600 V	1/0 AWG, 600 V	N/A
WLF40600H	2/0 AWG, 600 V	2/0 AWG, 600 V	N/A
WLF40750H	3/0 AWG, 600 V	3/0 AWG, 600 V	N/A

Additional requirements may be necessary, dependent on CEC, CE, VDE, or local codes.

Figure 5 shows the connections required for compliance to the CE EMC directive. Due to the leakage current associated with these filters (>3.5 mA), **one** of the following measures must be taken to be in compliance with specification EN 50178:

- The filter must be connected by a cable which is electrically parallel with the earth ground conductor. This conductor must meet the requirements of IEC 364-5-543 on its own.
- The ground conductor must have a cross section of at least 10 mm<sup>2</sup> (#6 AWG), or two parallel ground conductors must be used of the same size as the line conductors.
- The ground conductor must be monitored by a fault detection device that isolates the inverter from the power source in the event of a fault.

**The inverter must always be connected permanently (EN 50178) when using a WLF Series line filter, due to the leakage currents involved.**

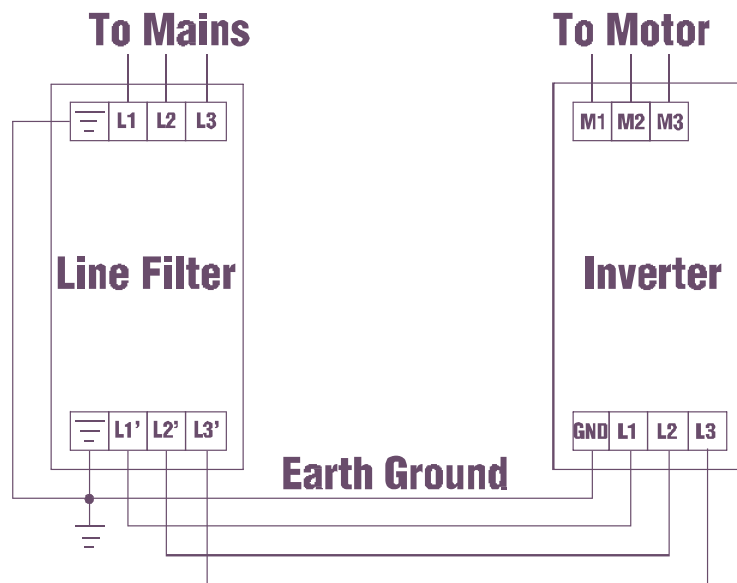

Figure 5

## SECTION 5

### INTERFERENCE SUPPRESSION MEASURES (ELECTROMAGNETIC COMPATIBILITY)

Electrical/electronic devices are capable of influencing or disturbing each other through connecting cables or other metallic connections. “Electromagnetic Compatibility” consists of two parts, “interference resistance” and “interference emission.” **Correct installation of the inverter in conjunction with any possible local interference suppression measures has a crucial effect on minimizing or suppressing mutual interference.**

The following notes refer to a power source that is **not** “contaminated” by high frequency interference. Other measures may be necessary to reduce or suppress interference if the power source is “contaminated.” No general valid recommendations can be given in such cases. Please consult TB Wood’s Electronics Application Engineering if all recommended interference suppression measures should not produce the desired result.

When dealing with RFI (radio frequency interference), the surface area of the conductors is a more critical parameter than the cross-sectional area. Since high frequency interference does not flow through the entire cross section of the conductor, but tends to stay toward its outer surface (skin effect), braided copper tapes of equal cross section should be used.

The inverter and all components used for interference suppression, particularly the shield of the motor cable, should be connected over as large a surface area as possible when passing over metallic surfaces. **Remove the paint from contact surfaces to assure a good electrical connection. See Figure 6 for recommended connection technique.**

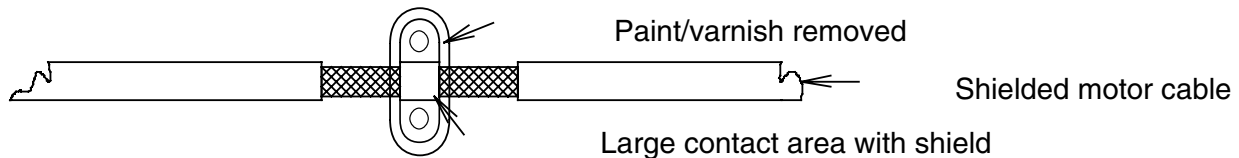

Figure 6

A central grounding point should be used for interference suppression. The ground cables are routed **radially** from this point. Loops in these lines are undesirable, and may lead to interference.

The shield cross section must not be damaged when the shield is connected to the continuing lines. This would raise the RF resistance of the shield and as such, radiate rather than discharge the RF energy traveling on the shield. Shields, particularly those on control cables, must not be routed through pin contacts (plug connectors). When shielded cables must pass through a plug connection, the metallic hand guard of the plug is used for the continuation of the shield. **It is strongly recommended that the shield be uninterrupted whenever possible.**

Use a shielded motor cable which is grounded over a large surface area at both ends. The shield on this cable should be uninterrupted. If a shielded motor cable can not be used, the unshielded motor line should be laid in a metal conduit or duct which is uninterrupted and grounded at both ends.

When selecting shielded cable for use as motor leads, it is important to select a cable which is designed for operation at the frequencies and power levels involved. Improper selection of motor cable can cause high potential to exist on the shield. This could cause damage to the inverter or other equipment, as well as being a potential safety hazard. Cables such as OLFlex<sup>1</sup> Series 150CY, 110CY, 110CS, 100CY, 100CS, and 540CP will work for this purpose. Siemens<sup>2</sup> Cordaflex (SM) also are acceptable. Some of these cables are VDE approved only; others carry VDE, UL, CSA, and combinations of these ratings. Be sure to confirm that the cable you are using meets the certification of the agency required.

If the installation requires the use of an output reactor, the reactor, like the line filter, should be placed as close as possible to the inverter.

Control wires longer than 3 feet must be run in shielded cable, and the shield must be terminated at common (**COM**) in the inverter. (Note that connection to COM, the circuit common, rather than earth ground, is allowed because E-trAC<sup>®</sup> inverters have isolated control inputs. If the inputs were not electrically isolated, the shield would have to be connected to earth ground). If the signal run exceeds 30 feet, a 0-20 mA or 4-20 mA signal should be used, as it will have better noise immunity than a low level voltage.

1. OLFlex Wire & Cable, 30 Plymouth Street, Fairfield, NJ 07004 (800) 774-3539

2. Siemens Energy and Automation, Inc., Power Cables, 3333 State Bridge Road, Atlanta, GA 30202 (800) 777-3539

Other loads connected to the power source may produce voltage transients (spikes) that may interfere with or damage the inverter. Line reactors or filters can be used on the input power to protect the inverter from such transients.

If the inverter is operated from switchgear devices or is in close proximity to switchgear devices (in a common cabinet), the following procedures are recommended as a precaution to prevent these devices from interfering with the inverter's operation:

- Wire the coils of DC devices with freewheeling diodes. The diodes should be placed as close as possible to the physical coil of the device.
- Wire the coils of AC devices with RC type snubber networks. Place the snubbers as close as possible to the physical coil of the device.
- Use shielded cables on all control and monitoring signals.

Route distribution cables (e.g., power and contactor circuits) separately and as far away from control and monitoring signal cables as possible.



## APPENDIX C

### EU DECLARATION OF CONFORMITY - '00

WE: TB Wood's Incorporated  
440 North Fifth Avenue  
Chambersburg, PA 17201  
USA

hereby declare that the products:

Product Name: WFC<sup>HT</sup> Series

Model Number: WFC1001-0, WFC2000-7, WFC2001-0,  
WFC2002-0, WFC2003-0, WFC2005-0,  
WFC2007-5, WFC2010-0, WFC2015-0,  
WFC2020-0, WFC2025-0, WFC4001-0,  
WFC4002-0, WFC4003-0, WFC4005-0,  
WFC4007-5, WFC4010-0, WFC4015-0,  
WFC4020-0, WFC4025-0, WFC4030-0,  
WFC4040-0, WFC4050-0, WFC4060-0,  
WFC4075-0

have been designed and manufactured in accordance with standards:

Low Voltage Directive: EN50178

Electromagnetic Compatibility: EN50081-1 - Adjustable speed electrical power drive systems

Part 3: EMC product standard including specific test methods

The products referenced above are for use of control of the speed of AC motors.

For Application information, consult the following document from TB Wood's Incorporated -- Form 1226.

Via internal mechanisms and Quality Control, it is verified that these products conform to the requirements of the Directive and applicable standards

Chambersburg, PA, USA -- 1 December 2000

Rick Kirkpatrick  
Director of Marketing  
Electronics Division





# Owner Warranty Registration

Please be sure to send in this sheet to register your purchase. Just fold the form with the Wood's address on the outside, secure with tape and mail. No postage is necessary.

PLEASE TYPE OR PRINT NEATLY

Your Name \_\_\_\_\_ Title \_\_\_\_\_

Company Name \_\_\_\_\_

Address \_\_\_\_\_

City \_\_\_\_\_ State \_\_\_\_\_ Zip \_\_\_\_\_

WFC<sup>HT</sup> Model **WFC**     -     Serial No. \_\_\_\_\_

Purchase Date \_\_\_\_\_ Distributor Name \_\_\_\_\_

Quantity Purchase to Date \_\_\_\_\_

### Application *(Please check the appropriate box)*

Compressor

Mixer

Conveyor

Printing Press

Fan/Blower

Pump

Drill Press

Punch Press

Feeder

Saw

Grinder

Winder/Unwinder

Knitting Machines

Other \_\_\_\_\_

Machining

\_\_\_\_\_

\_\_\_\_\_

Comments \_\_\_\_\_

\_\_\_\_\_

\_\_\_\_\_

**TB Wood's Incorporated**



NO POSTAGE  
NECESSARY  
IF MAILED  
IN THE  
UNITED STATES

**BUSINESS REPLY MAIL**  
FIRST CLASS MAIL PERMIT NO. 17 CHAMBERSBURG, PA

POSTAGE WILL BE PAID BY ADDRESSEE

**ATTN MARKETING MANAGER ELEC DIV  
TB WOODS INCORPORATED  
440 N FIFTH AVE  
CHAMBERSBURG PA 17201-9960**

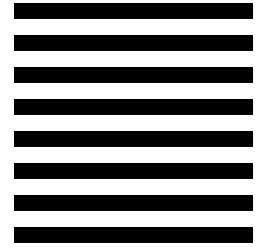

-----  
Fold Here

-----  
Fold Here





**TB Wood's**

---

## **TB Wood's Incorporated**

<http://www.tbwoods.com>

**440 North Fifth Avenue**

**Chambersburg, Pennsylvania 17201-1778**

**Telephone: 888-TBWOODS or 717-264-7161**

**Direct Dial (Sales) 717-267-2900**

**FAX: 717-264-6420**

### **T. B. Wood's Canada Ltd.**

750 Douro Street  
Stratford, Ontario, Canada N5A 6V6  
Telephone: 519-271-5380  
FAX: 519-271-3094

### **TB Wood's (México) S.A. de C.V.**

Oriente 237 No. 171  
Colonia Agrícola Oriental  
08500 México, D.F.  
México  
Telephone: 5-558-16-20  
FAX: 5-756-06-74

## **Plant Engineering Consultants**

(Wholly owned subsidiary)

521 Airport Road  
Chattanooga, Tennessee 37421  
Telephone: 800-437-3311 or 423-892-7654  
FAX: 423-894-0495

---

## **Distribution Centers**

### **ATLANTA**

700 Distribution Drive  
Atlanta, Georgia 30336  
Telephone: 800-789-6637  
FAX: 717-264-6420

### **EDMONTON**

9779-45th Avenue  
Edmonton, Alberta, Canada T6E 5V8  
Telephone: 403-439-7979  
FAX: 403-439-7661

### **CHICAGO**

1900 Touhy Avenue  
Elk Grove Village, Illinois 60007  
Telephone: 847-439-3788  
FAX: 847-439-0478

### **RENO**

4970 Joule Street  
Reno, Nevada 89502  
Telephone: 775-857-1800  
FAX: 775-857-1822

### **DALLAS**

1151 Empire Central  
Dallas, Texas 75247  
Telephone: 214-637-0850  
FAX: 214-637-0867

### **MONTREAL**

1073 Begin Street  
Ville St. Laurent  
Montreal, Quebec, Canada H4R 1V8  
Telephone: 514-332-4812  
FAX: 514-332-6842

---

## **Other Wood's Locations**

**Mt. Pleasant, MI • San Marcos, TX • Trenton, TN**