



Form 1410B

E-TRAC[®]

***SW1 Microdrive
User's Manual***



TB Wood's Incorporated
Chambersburg, PA USA



NEED HELP?

The manual that came with your drive answers most installation and startup questions that may arise. However, if you have any problems, please let your first call be to us!

**888-TBWoods
(888-829-6637)**

Press **8** then press **1** for Help

Normal business hours:
8:00 AM to 5:00 PM Eastern time
After-hours support is also available.

Your success is our success!
Electronics Application Engineering Team

E-trAC, **E-TRAC**[®], and  are registered trademarks of TB Wood's, Inc.

All other product names are trademarks of their respective companies.

Summary of SW1 Parameters

Par.	Description	Range	Default	Cust. Setting	See Page
P-01	Maximum speed	P-02 to 5*P-09 (max. 1kHz)	60 Hz		27
P-02	Minimum speed	0 to P-01 (max. 1kHz)	0 Hz		27
P-03	Accel ramp time(s)	0-3000 s	5 s		27
P-04	Decel ramp time(s)	0-3000 s	5 s		28
P-05	Stop mode select	0 - 2	0		28
P-06	V/F characteristic	0: Constant torque, Industrial 1: Pump/fan, HVAC	0.0 s		29
P-07	Fast stop(s)	0.0 to 25 s (disabled when 0.0 s)	0.0 s		29
P-08	Motor rated current	25%-100% of drive current rating	Drive rating		30
P-09	Motor rated frequency	25 Hz to 1 kHz	60 Hz		30
P-10	Motor rated speed	Motor name plate RPM - 0 Display is Hz	0		30
P-11	Voltage boost	0 - 25% of max. output voltage	3%		31
P-12	Terminal or keypad control	0 to 4	0		32
P-13	Trip log	Last four trips stored	Read only		33
P-14	Extended menu access	Code 0 to 9999	0		33

Extended Parameter Set *(cont'd on next page)*

Par.	Description	Range	Default	Cust. Setting	See Page
P-15	Motor rated voltage	230V product: 40V to 250V 480V product: 40V to 500V	0V		34
P-16	Analog input format (V / mA)	Volt.: 0-10V, 10-0V, -10-10V Curr.: 4-20mA, 0-20mA, 20-4mA	0-10V		34
P-17	PWM Carrier frequency	8, 16, 32 kHz (Sizes 1,2) 4, 8, 16 kHz (Size 3)	32 kHz 16 kHz		35
P-18	Relay output function	0-5	1		35
P-19	Digital inputs function select	0 - 12	0		36

E-trAC SW1 Microdrive User's Manual

Par.	Description	Range	Default	Cust. Setting	See Page
P-20	Preset/Jog speed 1	-P-01 (reverse) to P-01	60 Hz		37
P-21	Preset/Jog speed 2	-P-01 (reverse) to P-01	0 Hz		37
P-22	Preset/Jog speed 3	-P-01 (reverse) to P-01	0 Hz		37
P-23	Preset/Jog speed 4	-P-01 (reverse) to P-01	0 Hz		37
P-24	Slip compensation	20% to 250%	100%		37
P-25	Analog output function	0-3	0		38
P-26	V/F characteristic adjustment factor	20% to 250%	100%		38
P-27	Skip freq/speed	0 to P-01 (max)	0 Hz		39
P-28	Skip freq/speed band	0 to 100% of rated speed/freq. P-09.	0 Hz		39
P-29	V/F char. adjustment freq.	0 to base frequency (P-09) (function disabled if set to 0)	0 Hz		38
P-30	Drive start mode	0 - 4	0		40
P-31	DC injection voltage	0.1 to 20% of max. voltage	10%		40
P-32	DC injection braking time	0 to 250 s	0 s		40
P-33	DC injection on enable	0=inactive; 1=enabled	0		40
P-34	External brake resistor	0 - 2	0		41
P-35	Speed reference scaling factor (analog or digital)	1% to 500%	100%		42
P-36	Drive address (s-comms)	0 - 63	1		43
P-37	Access code definition	0 - 9999	101		43
P-38	Para. access lock	0 - 2	0		44
P-39	Hours run meter	0 - 99999 hours	Read only		44
P-40	Drive identifier	Drive rating/Software version	Read only		45

E-trAC SW1 Microdrive User's Manual

Table of Contents

1 Introduction	1
1.1 Product overview	1
1.2 Overview of this manual	1
1.3 Publication history	2
2 Technical characteristics	3
2.1 Interpreting model numbers	3
2.2 Power and current ratings	4
2.3 Environmental specifications	5
2.4 Electrical specifications	5
2.5 Protective features	5
2.6 Conformance	6
2.7 Physical dimensions	6
3 Receiving and installation	9
3.1 Preliminary inspection	9
3.2 Installation precautions	10
3.3 Recommended sizing for painted steel enclosures	10
3.4 Mechanical installation	11
3.5 Electrical installation	13
4 Connections and wiring	15
4.1 General wiring information	15
4.1.1 Wiring practices	15
4.1.2 Considerations for power wiring	15
4.1.3 Considerations for control wiring	16
4.2 Input line requirements	16
4.2.1 Line voltage	16
4.2.2 Line capacity	16
4.2.3 Phase imbalance	16
4.2.4 Typical power connections	16
4.3 Dynamic braking	19
4.4 Terminals and I/O	20
5 Parameters and programming	23
5.1 Parameter definitions and access	23
5.2 Programming with the keypad	24
5.3 Descriptions of standard parameters	26
5.4 Descriptions of advanced parameters	34
6 Fault codes, drive status and diagnostics	47
7 SW1 Microdrive options	51

NOTES

1. INTRODUCTION

1.1 Product overview

The E-trAC SW1 AC Microdrive provides ease of use plus simple installation and start-up. With only 14 standard parameters to adjust for basic operation, start-up is fast and easy. For more advanced user requirements, the extended parameter set gives access to increased levels of functionality. The SW1 adds a standard infrared port for wireless transfer of parameters from a PDA, in either Pocket PC® or Palm® operating systems. This unique capability allows you to copy, upload, download, edit and file drive parameter sets without the need for a special option or cables.

The SW1 product family includes a wide variety of models to suit almost any input voltage requirement. An 'x' in the following table indicates what models are currently available:

Horsepower	115 Vac	230 Vac	460 Vac
.5	X	X	
1	X	X	X
1.5	X		
2		X	X
3		X	X
5		X	X
7.5		X	X
10			X
15			X
20			X

1.2 Overview of this manual

This manual contains specifications, receiving and installation instructions, configuration, description of operation, and troubleshooting procedures for SW1 Microdrive devices.

1.3 Publication history

Date	Form Number	Nature of Change
October 2004	1410A	First release
February 2005	1410B	Corrections and additions: <ul style="list-style-type: none">• P-17 range values corrected in parameter table (front matter)• Model numbers updated• Table 2-1 updated, note added• Operating temperature in Table 2-2 corrected• Enclosure dimension tables added• Max. motor cable length data added to Fig. 4-1

2. TECHNICAL CHARACTERISTICS

2.1 Interpreting model numbers

The model number of the SW1 Microdrive appears on the shipping carton label and on the technical data label affixed to the model. The information provided by the model number is shown below.

The SW1 model numbers are created using an intelligent part numbering system. Figure 2-1 shows how to read an SW1 model number:

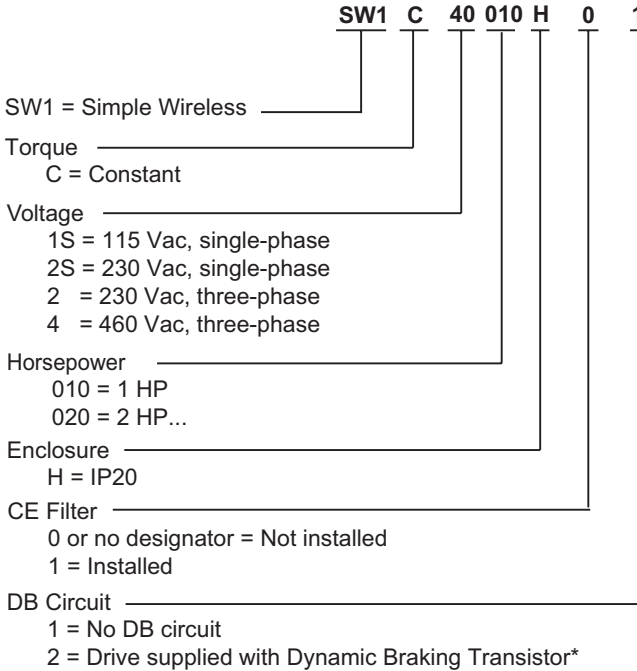

* Resistor sold as separate option

Figure 2-1.

2.2 Power and current ratings

Model Number	Motor (HP) (CT/ VT)	Power (kW) (CT/ VT)	Input Voltage (Vac)	Fuse/ MCB Amp Rating (A)	Output Voltage (Vac)	Output Curr. (A)	Minimum Brake Resistor (Ohms)
SW1C1S005H01	.5/1.5	.37/1.37	115 +/- 10% 1 Phase	10	0 - 230	2.3	N/A
SW1C1S010H01	1/1	.75/1.75		20	0 - 230	4.3	33
SW1C1S015H02	1.5/1.5	1.1/1.1		30	0 - 230	5.8	22
SW1C20005H01	.5/1.5	.37/1.37	200 to 240 +/- 10% 1 or 3 Phase	10	0 - 200/230	2.3	N/A
SW1C20010H01	1/1	.75/1.75		10	0 - 200/230	4.3	N/A
SW1C20020H01	2/2	1.5/1.5		20	0 - 200/230	7	N/A
SW1C20020H02	2/2	1.5/1.5		20	0 - 200/230	7	33
SW1C20030H02	3/3	2.2/2.2		30	0 - 200/230	10.5	22
SW1C20050H02	5/7.5	3.7/5.5	3 Phase only	32	0 - 200/230	18	15
SW1C20075H01	7.5/10	5.5/7.5		40	0 - 200/230	25	15
SW1C40010H02	1/1	.75/1.75	380 to 480 +/- 10% 3 Phase	5	0 - 380/480	2.2	47
SW1C40020H02	2/2	1.5/1.5		10	0 - 380/480	4.1	47
SW1C40030H02	3/3	2.2/2.2		10	0 - 380/480	5.8	47
SW1C40050H02	5/5	3.7/3.7		16	0 - 380/480	9.5	33
SW1C40075H02	7.5/10	5.5/7.5		20	0 - 380/480	14	22
SW1C40100H02	10/15	7.5/11		32	0 - 380/480	18	22
SW1C40150H02	15/20	11/15		40	0 - 380/480	25	22
SW1C40200H02	20/20	15/15		40	0 - 380/480	29.5	22

Table 2-1.

 CAUTION
<p>EQUIPMENT DAMAGE HAZARD</p> <p>Protect the drive by using slow-blowing Class J fuses (HRC) or MCB located in the incoming power supply of the drive.</p> <p>Failure to follow this instruction can result in injury or equipment damage.</p>

2.3 Environmental specifications

Operating temperature	0 °C to +50 °C (32 °F to 122 °F)
Storage temperature	-20 °C to +65 °C (-4 °F to 149 °F)
Maximum heatsink temperature	100 °C (212 °C)
Humidity	0-95% non-condensing
Altitude	1000 m (3300 ft) without derating
Maximum vibration	5.9 m/s ² (19.2 ft/s ²) (0.6 G)
Acoustic noise	80 dba sound power at 1 m (3 ft)
Cooling	Natural convection (0.5 and 1 HP models) Fan cooling (2 HP and larger models)

Table 2-2.

2.4 Electrical specifications

	115 Vac Models	240 Vac Models	480 Vac Models
Input Voltage	115 Vac +/- 10%	200 - 240 +/- 10%	380 - 480 +/- 10%
Line Frequency	48 to 62 Hz		
Phase Imbalance	NA	3% on 3 - Phase	3%
Source kVA (Maximum)	10 times the inverters kVA rating		
Control System	Voltage Vector PWM		
Output Frequency Range	0 to 1000 Hz		
Output Voltage	0 to 230 Vac	0 to 100% of line voltage	0 to 100% of line voltage
Overload Capacity	150% for 60 seconds, 175% for 2 seconds		
De-rating	de-rate output current 5% per degree C above 50 C (130 F)		
Frequency Setting	Keypad, IR or external signal		
Agency listings	UL, cUL, CE, C - tick		

Table 2-3.

2.5 Protective features

Ground Fault	Phase - Ground short circuit
Short Circuit	Phase - Phase short circuit
Motor Overload	Output current thermal overload (I ² t)
Over Current	Output phase over-current trip
Over Voltage	DC Link over voltage
Under Voltage	DC Link under voltage
Over Temperature	Heatsink thermal overload (trip @ 100 °C)
Brake Resistor Short	Brake resistor short circuit
Phase Loss	3 - Phase models

Table 2-4.

2.6 Conformance

All products conform to the following international standards:

- IEC 664-1 Insulation co-ordination within low voltage systems
- UL 508C Power conversion equipment
- EN 61800-3 Adjustable Speed electrical power drive systems – Pt. 3
- EN 61000-4 EMC – Generic emissions standard (Industrial level)
- EN 61000-2 EMC – Generic immunity standard (Industrial level)
- Enclosure protection level according to NEMA 250, EN 60529
- Flammability rating according to UL 94

2.7 Physical dimensions

The following dimensions apply to the standard SW1 units, sizes 1-3.

	Size 1	Size 2	Size 3
Length / mm/in	155/6.1	260/10.2	260/10.2
Width / mm/in	80/3.14	100/3.94	171/6.7
Depth / mm/in	130/5.11	175/6.9	175/6.9
Weight/ kg/lbs	1.1/2.4	2.6/5.7	5.3/11.7
Fasteners	2 * M4		4 * M4
Power terminal torque settings	1 Nm/8.8 inlbs	1 Nm/8.8 inlbs	1 Nm/8.8 inlbs

Table 2-5.

Dimension diagrams: SW1 Size #1

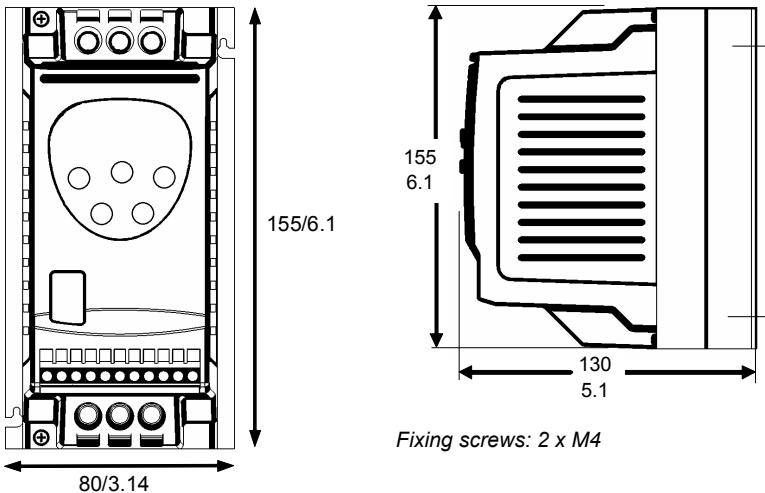
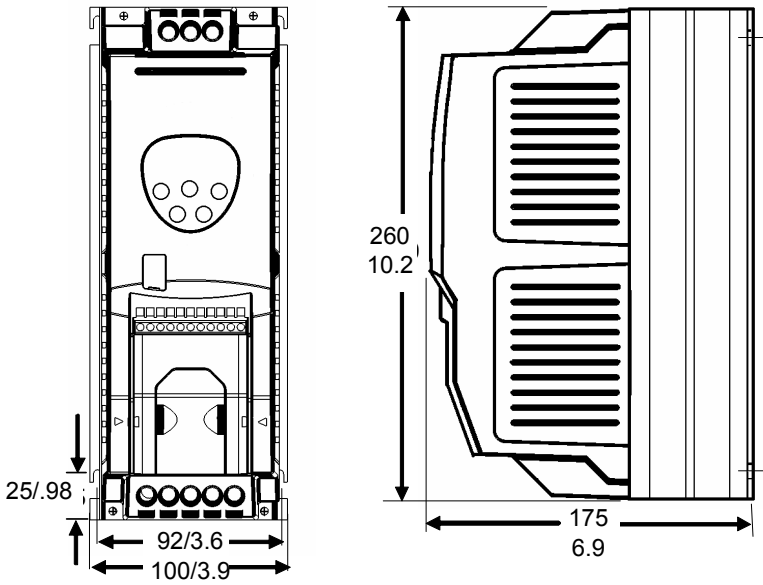

Figure 2-2.

Dimension diagrams: SW1 Size #2



Mounting screws: 2 x M4

Figure 2-3.

Dimension diagrams: SW1 Size #3

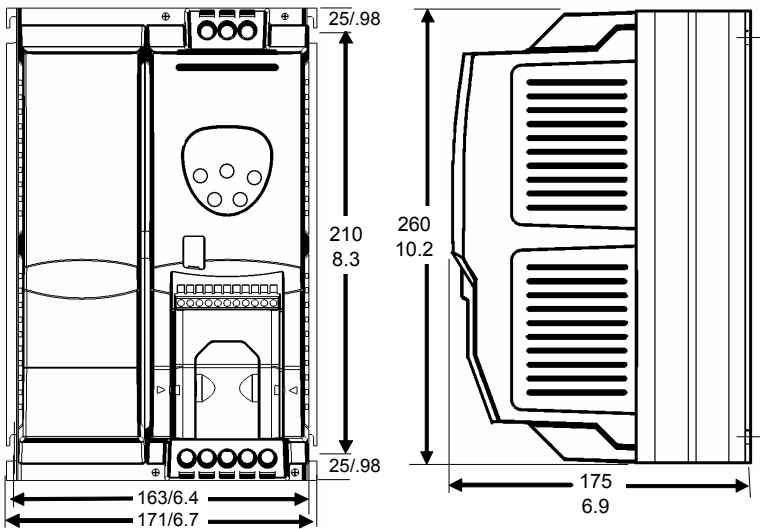

Mounting screws : 4 x M4

Figure 2-4.

NOTES

3. RECEIVING AND INSTALLATION

3.1 Preliminary inspection

Before storing or installing the SW1 Microdrive, thoroughly inspect the device for possible shipping damage. Upon receipt:

1. Remove the drive from its package and inspect exterior for shipping damage. If damage is apparent, notify the shipping agent and your sales representative.
2. Inspect the drive for any apparent damage or foreign objects. Ensure that all mounting hardware and terminal connection hardware is properly seated, securely fastened, and undamaged.
3. Read the technical data label affixed to the drive and ensure that the correct horsepower and input voltage for the application has been purchased.
4. If you will be storing the drive after receipt, place it in its original packaging and store it in a clean, dry place free from direct sunlight or corrosive fumes, where the ambient temperature is not less than $-20\text{ }^{\circ}\text{C}$ ($-4\text{ }^{\circ}\text{F}$) or greater than $+65\text{ }^{\circ}\text{C}$ ($+149\text{ }^{\circ}\text{F}$).



CAUTION

EQUIPMENT DAMAGE HAZARD

Do not operate or install any drive that appears damaged.

Failure to follow this instruction can result in injury or equipment damage.

3.2 Installation precautions

Improper installation of the SW1 Microdrive will greatly reduce its life. Be sure to observe the following precautions when selecting a mounting location.

NOTE: Failure to observe these precautions may void the warranty!

- Do not install the drive in a place subjected to high temperature, high humidity, excessive vibration, corrosive gases or liquids, or airborne dust or metallic particles. See “[Environmental specifications](#)” on page 5 for temperature, humidity, and maximum vibration limits.
- Do not mount the drive near heat-radiating elements or in direct sunlight..
- Mount the drive vertically and do not restrict the air flow to the heat sink fins.
- The drive generates heat. Allow sufficient space around the unit for heat dissipation.

3.3 Recommended sizing for painted steel enclosures

Drive Power Rating		Sealed Unit Dimensions (mm / in)		
		W	H	D
Size 1	0.37 kW/0.5 HP 230V	200/8	250/10	200/8
Size 1	0.75 kW/1 HP 230V / 460V	250/10	300/12	200/8
Size 1	1.5kW/2.0 HP 230V / 460V	300/12	400/16	250/10
Size 2	2.2 kW/3.0 HP 480V	300/12	400/16	300/12
Size 2	2.2kW/3.0 HP 230V	450/18	600/24	300/12
	4.0kW 5.0 HP 460V			

Table 3-1. Dimensions for Non-Vented Enclosures

Drive Power Rating		Vented Unit			Force Vented (with fan)			Air Flow
		W	H	D	W	H	D	
		(mm / in)			(mm / in)			
Size 1	All ratings	300/12	400/16	150/6	200/8	300/12	150/6	>15m ³ / h
Size 2	All ratings	400/16	600/24	250/10	200/8	400/16	250/10	>45m ³ / h

Table 3-2. Dimensions for Vented Enclosures

Calculating watts loss for enclosure sizing: The SW1 Microdrive has an average watts loss of 2% of its kW rating when running at full rated load at the default PWM carrier frequency. As a general rule the 2% loss will be worst case unless the drive is running in an overloaded condition or the PWM carrier frequency is set to the maximum setting on size 2 and size 3 models.

Example: 5 HP units have a kW rating of 4.0. Given $4.0 \text{ kW} \times .02 = 80 \text{ watts}$

3.4 Mechanical installation

SW1 drives can be installed side-by-side with their heatsink flanges touching. This gives adequate ventilation space between them. If the drive is to be installed above another drive or any other heat-producing device, the minimum vertical spacing is **100mm/ 3.94 in.** The enclosure should either be force-ventilated or large enough to allow natural cooling (**allow (0.1 m³ or 3.53 sq. ft. per kW of drive rating)**). See Figure 3-1 for an illustration of minimum clearance needed when installing SW1 drives.

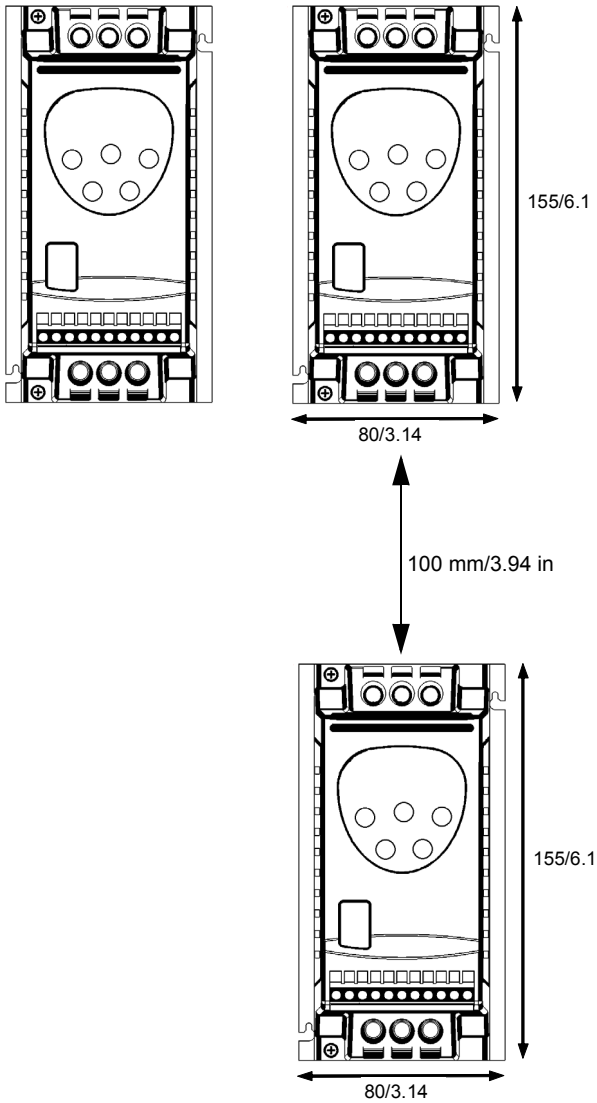



Figure 3-1.

3.5 Electrical installation

 DANGER
<p>ELECTRICAL SHOCK HAZARD</p> <ul style="list-style-type: none"> • SW1 drives should be installed only by qualified electrical personnel and in accordance with local and national regulations and codes of practice. • Disconnect and ISOLATE the drive before attempting any work on it. High voltages may be present at the DC bus terminals and within the drive for up to 10 minutes after disconnecting the electrical supply. • Where the electrical supply to the drive is through a plug and socket connector, do not disconnect until 10 minutes have elapsed after turning off the supply. • Ensure correct grounding connections. • The ground cable must be sufficient to carry the maximum supply fault current which normally will be limited by the fuses or MCB.. <p>Failure to follow this instruction can result in death, serious injury, and equipment damage.</p>

 CAUTION
<p>EQUIPMENT DAMAGE HAZARD</p> <ul style="list-style-type: none"> • Ensure that the supply voltage, frequency and number of phases (single or three phase) correspond to the rating of the drive as delivered. • An isolator or similar should be installed between the power supply and the drive. • Never connect the incoming power supply to the drive output terminals U, V, W. • Protect the drive by using slow-blowing Class J fuses (HRC) or MCB located in the incoming power supply of the drive. • Do not install any type of automatic switchgear between the drive and the motor. • Wherever control cabling is close to power cabling, maintain a minimum separation of 100 mm and arrange crossings at 90° . • Ensure that adequate shielding or armouring of power cables is effected. • Ensure that all terminals are tightened to the appropriate torque. <p>Failure to follow this instruction can result in injury or equipment damage.</p>

NOTES

4. CONNECTIONS AND WIRING

This chapter provides information on connecting power and control wiring to the SW1 Microdrive.

4.1 General wiring information

4.1.1 Wiring practices

When making power and control connections, observe these precautions:

- Never connect input AC power to the motor output terminals U, V, or W, or damage to the drive will result.
- Power wiring to the motor must have the maximum possible separation from all other power wiring. Do not run in the same conduit; this separation reduces the possibility of coupling electrical noise between circuits.
- Cross conductors at right angles whenever power and control wiring cross.
- Good wiring practice also requires separation of control circuit wiring from all power wiring. Since power delivered from the drive contains high frequencies which may cause interference with other equipment, do not run control wires in the same conduit or raceway with power or motor wiring.

4.1.2 Considerations for power wiring

Power wiring refers to the line and load connections made to terminals L1, L2, L3, and U, V, W respectively. Select power wiring as follows:

- Use only UL-recognized wire.
- Wire voltage rating must be a minimum of 300 V for 115 or 230 Vac systems and 600 V (Class 1 wire) for 460 Vac systems.
- Grounding must be in accordance with NEC and CEC. If multiple SW1 drives are installed near each other, each must be connected to ground. Take care not to form a ground loop.
- Select wire gauge based on 125% of the continuous output current rating of the drive.
- Select wire gauge from wire tables for 60 °C and 70 °C insulation rating. It must be of copper construction, and must be selected based on an ambient temperature of not more than 40 °C (104 °F) where the wire is in free air or conduit (length not having more than a 5% voltage drop). (Use wire rated 90 °C where the ambient temperature is greater than 40 °C.)

See [Table 2-1 on page 4](#) for the continuous output ratings for the drive.

4.1.3 Considerations for control wiring

Control wiring refers to the wires connected to the control terminal strip. Select control wiring as follows:

- Shielded wire is recommended to prevent electrical noise interference from causing improper operation or nuisance tripping.
- Use only UL-recognized wire.
- Wire voltage rating must be at least 300 V for 230 Vac systems.

4.2 Input line requirements

4.2.1 Line voltage

See [Table 2-1 on page 4](#) for the allowable fluctuation of AC line voltage for your particular SW1 model. A supply voltage above or below the limits given in the table will cause the drive to trip with either an overvoltage or undervoltage fault.

Use caution when applying the SW1 Microdrive on low-line conditions. For example, an SW1 2000 series inverter will operate properly on a 208 Vac line, but the maximum output voltage will be limited to 208 Vac.

However, if a motor rated for 230 Vac line voltage is controlled by this drive, higher motor currents and increased heating will result. Therefore, ensure that the voltage rating of the motor matches the applied line voltage.

4.2.2 Line capacity

If the source of AC power to the SW1 Microdrive is greater than 10 times the kVA rating shown in [Table 2-3 on page 5](#), an isolation transformer or line reactor is recommended. Consult the factory for assistance in sizing the reactor.

NOTE: *SW1 Microdrive devices are suitable for use on a circuit capable of delivering **not more than 2500 rms symmetrical amperes at 10% above the maximum rated voltage.***

4.2.3 Phase imbalance

Phase voltage imbalance of the input AC source can cause unbalanced currents and excessive heat in the drive's input rectifier diodes and DC bus capacitors. Phase imbalance can also damage motors running directly across the line.

4.2.4 Typical power connections

[Figure 4-1](#) shows the terminals for line power and motor output. For input line requirements, refer to ["Electrical specifications" on page 5](#).

Connect the drive according to Figure 4-1 below, ensuring that motor terminal box connections are correct.

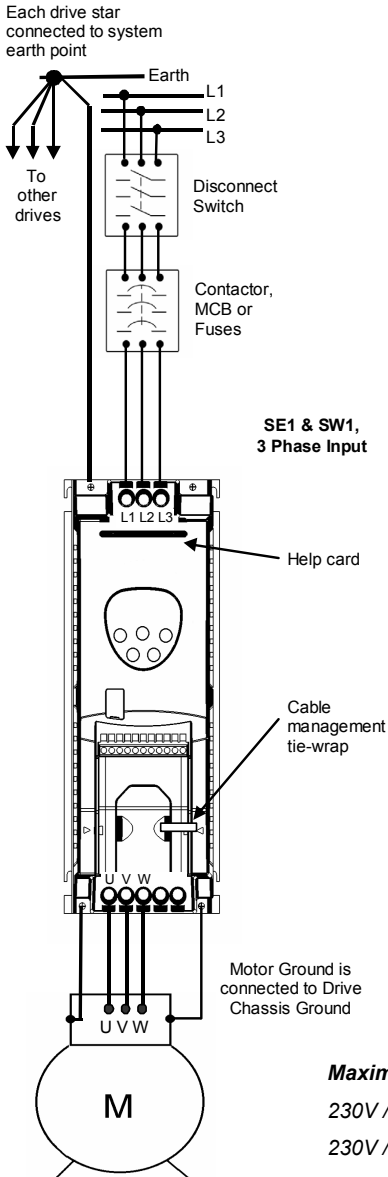

Note: If the drive is fitted with an EMC filter, the filter should be physically close to the drive. For maximum effectiveness, the metal case of the filter and the heat sink of the drive should be electrically connected; that is, screw both to a metal back plate and ensure metal-to-metal contact.

Connecting the SW1 Microdrive

Maximum motor cable length:

230V / 460V models size 1 = 25m/80 ft

230V / 460V models sizes 2, 3 = 100m/328 ft

Figure 4-1.

E-trAC SW1 Microdrive User's Manual

Note that when testing for a ground fault, **do not short** any motor lead (U, V, or W) back to an input phase (L1, L2, or L3).

It is necessary to provide fuses and a disconnect switch for the input AC line in accordance with all applicable electrical codes. The SW1 Microdrive is able to withstand a 150% overload for 60 s.

It is recommended that the power cabling be 3-core or 4-core PVC-insulated screened cable, laid in accordance with local industrial regulations and codes of practice.

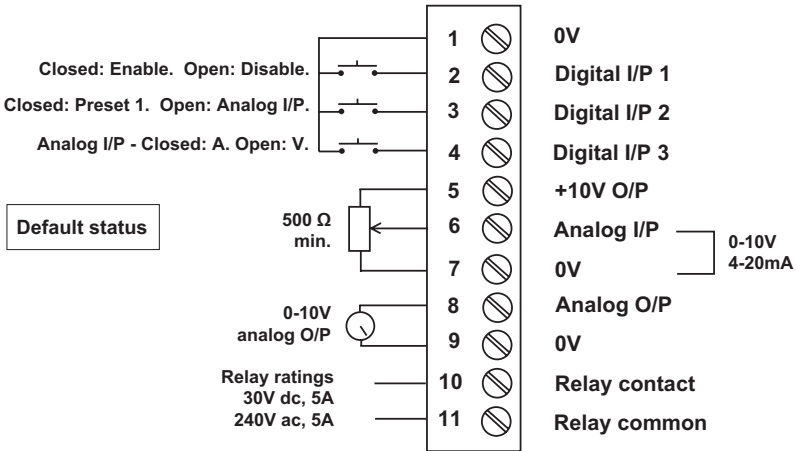

Figure 4-2.

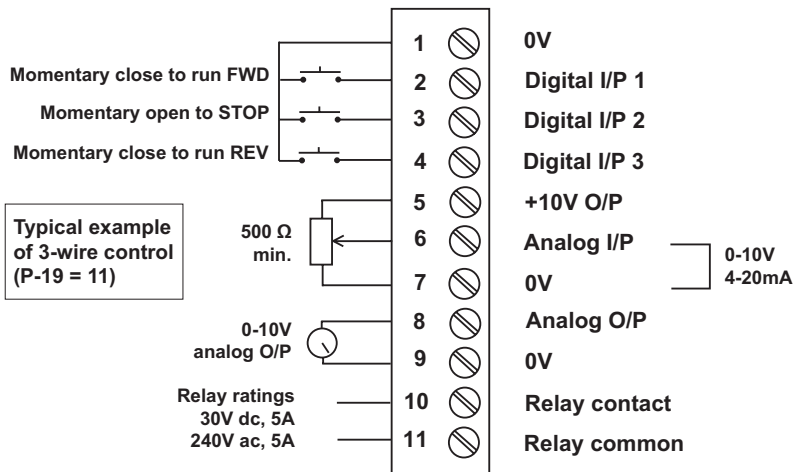

Figure 4-3.

4.3 Dynamic braking

In cases where short stopping times or high inertia loads require additional braking capacity, install an external resistor.

The SW1RES01 option is a 50 ohm 250 watt resistor that can be fitted on the heatsink of the size 2 and 3 units, and is designed to have adequate dynamic braking for most applications. In cases where short stopping times or high inertia loads require additional braking capacity, install a third-party external resistor of greater power rating. [Table 2-1 on page 4](#) lists the minimum resistance values for each model:

To install an SW1RES01 external resistor, connect the external resistor to the **+** and **BR** terminals. See Form 1415, *SW1RES01*, for further information. You must also set parameter **34** to data value **1** or **2** (see description of parameter [P-34](#) on page 41).

When using a third-party external resistor, use the following equation to compute the duty cycle for the DB resistor:

$$\text{Duty Cycle} = (\text{DB Operating Time} / \text{Full Cycle Time}) \times 100\%$$

You should also verify with the manufacturer of the selected resistor that the resistor is indeed appropriate for your application. Contact TB Wood's Electronic Application Engineering for further assistance with other possible sizing limitations.

4.4 Terminals and I/O

Power terminals, grounding and shielding

SW1 products have the power input at the top of the unit and the motor connection at the bottom. In addition, sizes 2 and 3 have a connection for an external braking resistor next to the motor connections.

The ground connection is available on each corner of the heatsink, thereby grounding the heatsink and forming a low impedance path between motor ground and supply ground which bypasses the PCBs.

Digital inputs

Three digital inputs are available. All of these are programmable in terms of functionality. This functionality is defined by P-19 (see parameter descriptions in Chapter 5, "Parameters and programming" on page 23).

All inputs are isolated from the drive power stage to **2.5kV**. The inputs are both **pull-up** and **pull-down** logic activated (auto-detected by the SW1). Any digital input will be activated by an input voltage of **<8V** (pull-down logic) or a voltage of **>21V** (positive logic). All voltages are referenced to the common 0V terminals (terminals 1, 7 or 9).

All inputs are designed to withstand up to **50V DC** without damage.

Analog input

A bipolar 12-bit (4000 step), fully isolated, analog input is available. The level of isolation is **2.5kV** from the power stage. This input is used as the speed reference input, and can be configured as a voltage or current input. The maximum response delay of this input is **< 8ms**; in other words, within 8ms the drive will respond completely to any change on the analog input. The input is over-voltage protected up to **50V**.

When used in bipolar voltage mode (-10V ... 10V), the input symmetry is better than 0.2%.

The analog input format is set using P-16 (see parameter descriptions in Chapter 5, "Parameters and programming" on page 23). Available settings are 0..10V, 4..20mA, 0..20mA or 20..4mA, 10..0V or -10..10V.

A 10V, 30mA voltage output is available on terminal 5 to allow the speed reference to be set using only an external potentiometer (500 Ohms or greater). The 10V output is short-circuit and over-voltage protected.

Analog output

A single-ended 10-bit (1000 step) analog output with a bandwidth of >100Hz is available, delivering an output voltage between 0 and 10V. This can be configured by software to represent either speed or motor current.

In motor speed mode, the output voltage is scaled linearly between 0 and 10V, representing 0 to maximum speed (as set in **P-01**). In motor current mode, the output voltage is scaled linearly between 0 and 10V, where 10V represents 2x rated current, as set in **P-08**.

The analog output can source up to **20mA** and is short circuit / over-voltage protected.

Signal terminals overview

The signal terminal block has the following signal connections (see also [Figure 4-2 on page 18](#)).

- 0V common connect digital inputs to this to activate
- Digital input 1 active low (connect to 0V to activate)
- Digital input 2 active low (connect to 0V to activate)
- Digital input 3 active low (connect to 0V to activate)
- +10V ref out 10V ref for analog input (pot supply +)
- Analog input 0 .. 10V (4 .. 20mA when Iref enable)
- 0V common 0V ref for analog input (pot supply -)
- Analog output 0 .. 10V programmable analog output
- 0V common 0V ref for analog output
- Relay common N.O. relay contact *
- Relay N.O. N.O. relay contact *

** The relay contacts are rated at 250V AC / 30V DC @ 10A*

NOTES

5. PARAMETERS AND PROGRAMMING

5.1 Parameter definitions and access

You can access and program parameters as described below:

Normal (real-time) display mode (non parameter edit mode) allows the key variables listed below to be displayed in real time.

	Speed	0 ... ±60000	rpm
H	Frequency	0 ... ±1000	Hz
A	Motor current	0 ... 100.0	A

You can scroll between these variables by pressing and releasing the **<Navigate>** key within 1s. The scrolling mechanism rolls over from **Load** back to **speed**.

To enter parameter access mode, press the **< Navigate>** button for approximately 1s. The display changes from indicating operational speed to "P-XX", where XX represents the parameter last accessed during the previous commissioning session. The value of XX can be incremented or decremented using the **<up>** / **<down>** keys. The parameter scrolling mechanism rolls over from the maximum to minimum parameter number and vice versa.

Pressing and releasing the **<Navigate>** key once more will then display the current value of the selected parameter. This can then be edited within the limits of that parameter, unless parameter write access has been disabled (P-38).

Pressing the **<Navigate>** key once more toggles back to display the parameter number in case further editing is required. If the **<Navigate>** key is held for approx. 1 second, the display reverts to displaying the real-time values (speed/freq or current/load). The display will also revert to displaying the selected real-time value if no buttons are pressed for >20s if parameters P-01 ...P-40 are being accessed, and >60s if P-00 (watch windows) is being accessed.

Refer to Figure 5-2 on page 25 for the keypad features.

The operation of the parameters is illustrated in Figure 5-1 below.

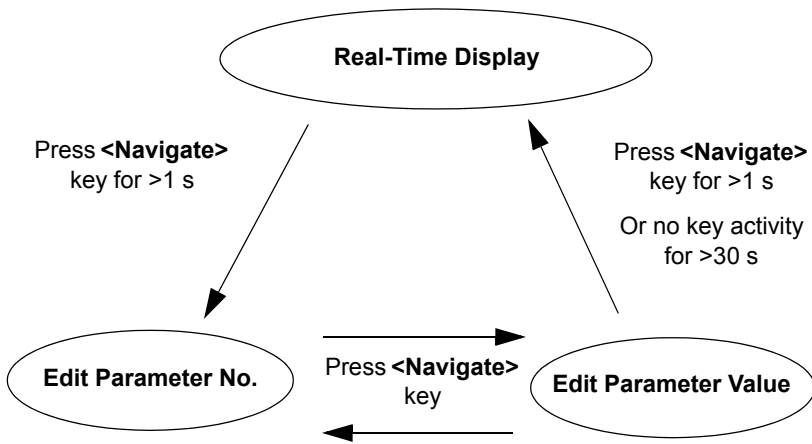

Figure 5-1.

The parameters are split into **standard parameters** (for example, max / min speed), which are accessible in the basic menu, and **advanced parameters**, accessible in the extended menu.

5.2 Programming with the keypad

When the drive is delivered from the factory, only the Standard Parameter Set is accessible. Figure 5-2 shows the SW1 keypad and its features.

- **To access the Standard Parameter Set**, press the **Navigate** key (⇔) for >1 sec.
- Scroll through P-01 to P-14 (and roll over to P-01) by pressing the Up (▲) or Down arrow (▼).
- **To display the parameter value**, press the **Navigate** key (⇔).
- **To edit the parameter value**, press the up (▲) or down arrow (▼).
- **To return to the parameter number**, press the **Navigate** key (⇔).
- **To store a value and / or exit from edit mode**, press the **Navigate** key (⇔) for >1 sec or press no button for >20 sec.

To access the Extended Parameter Set, set P-14 = 101 and press the **Navigate** key (⇔).

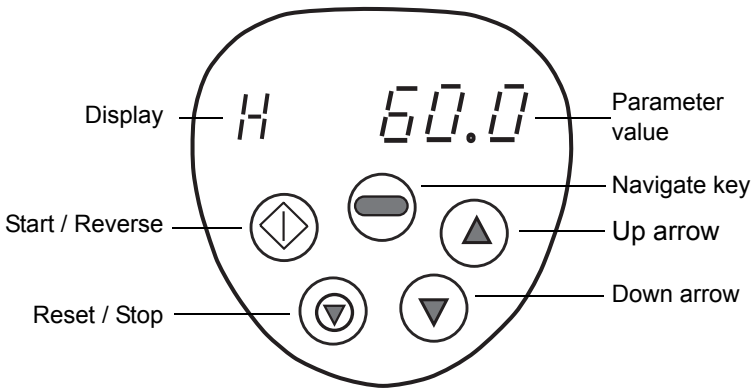

Figure 5-2.

NOTES:

- When the drive display is flashing, the unit is in an overloaded condition. Check the motor load.
- To restrict unauthorized access, make P-37 = any value from 0 to 9999.
- When in the Extended Parameter Set (except P-00), the display will revert to normal if no button is pressed for >20 sec.
- When P-00 is accessed, the display will revert to normal if no button is pressed for >60 sec.

TO SAVE CHANGES to Parameter settings, switch the power supply off and wait for the drive to power down (screen blank) before switching on.

NOTE that this assumes P-38 = 0 (default). If P-38 = 1, changes are not saved.

TO RESTORE ALL DEFAULT VALUES, stop the drive; when the display shows **Stop**, press and hold the up arrow (▲), the down arrow (▼), and **STOP** keys simultaneously for 1 second. The display will show **P-dEF**. Access code P-37 will revert to 101 but the hours-run meter P-39 is **not affected**. Press **STOP** to resume normal operation.

5.3 Descriptions of standard parameters

The following list provides an overview of the standard parameter set :

Parameter zero (P-00)

Parameter zero (P-00) is a special read-only parameter which provides visibility, a window into the internal control functions of the drive, allowing key internal nodes to be monitored. It is intended primarily as a commissioning and diagnostic aid. It is accessible in the extended parameter set. Any one of these values can be selected by scrolling between them using the **<up>** and **<down>** keys, as in the case of any other parameter. The currently selected variable is indicated by a single digit number (**0 to 9**) on the left-hand side of the drive display.

The following internal variables can be monitored using P-00 :

1	Unscaled analog input (from user terminals)	% of analog input voltage
2	Speed ref from scaled (P-35) analog input	Hz
3	Pre ramp frequency ref	Hz
4	Post ramp frequency ref	Hz
5	Slip frequency	Hz
6	Stator frequency	Hz
7	Applied Motor voltage	V
8	DC Bus Volts	V
9	Thermistor voltage	

Display of Slip Frequency

In its factory default state, the SW1 has slip compensation **disabled**, since the rated speed of the motor is not known to the drive. In this case, P-10 = 0 and watch window 5 above will be zero in all cases.

Once the motor rated speed in rpm has been entered in P-10, slip compensation is automatically activated and the instantaneous value of slip will be displayed in watch window 5. Slip compensation automatically attempts to maintain a constant rotor speed under varying load conditions by modifying the applied stator frequency as a function of load current.

Once P-10 has been entered, the real-time display values will also include speed in rpm in addition to applied motor frequency in Hz and motor current in A.

P-01 - Maximum speed limit

This parameter sets the upper limiting boundary defining the maximum frequency (speed) that can be applied to the motor in any mode of operation.

This parameter will be displayed in Hz in the factory default state or whenever the motor rated speed parameter (P-10) is zero. If the motor rated speed in rpm has been entered in P-10, this parameter will be displayed in rpm.

Maximum value: 5 x base frequency (that is, 5 x P-09)

Minimum value: value of P-02

Default value: 60 Hz

P-02 - Minimum speed Limit

This parameter sets the lower limiting boundary defining the minimum frequency (speed) that can be applied to the motor in any mode of operation.

This parameter will be displayed in Hz in the factory default state or whenever the motor rated speed parameter (P-10) is zero. If the motor rated speed in rpm has been entered in P-10, this parameter will be displayed in rpm.

The speed only drops below this level after the drive enable signal is removed, when the drive will ramp the output frequency to zero.

Maximum value: value of P-01

Minimum value: 0

Default value: 0 Hz

P-03 - Acceleration ramp time

This parameter defines the time taken in seconds for the output frequency (speed) to increase from zero to the rated frequency (speed), as defined in parameter P-09.

Note that the ramp rate is unaffected by changing either the maximum or minimum speed limits (P-01, P-02) since the ramp time is related to P-09 and not P-01 / P-02.

When set to the minimum ramp time of 0s, the output will change to the requested value within 8ms of the action being requested.

Maximum value: 3000s

Minimum value: 0s

Default value: 5.0 s

P-04 - Deceleration ramp time

This parameter defines the time taken in seconds for the output frequency (speed) to decrease from the rated frequency (value in P-09) to zero.

Note that the ramp rate is unaffected by changing either the maximum or minimum speed limits (P-01, P-02) since the ramp time is related to P-09 and not P-01 / P-02.

When set to the minimum ramp time of 0s, the output will change to the requested value within 8ms of the action being requested.

Maximum value: 3000s

Minimum value: 0s

Default value: 5.0 s

P-05 - Stop mode select

This parameter defines the way in which the motor comes to a standstill when the drive enable signal is removed.

When **set to zero** (factory default), the drive speed is ramped down to zero according to the setting of P-04 whenever the drive enable signal is removed. The drive will only be disabled when the SW1 output frequency reaches zero. (Note that DC injection braking can be used to hold zero speed if required – see page 40 for descriptions of parameters P-31 and P-32.)

In the event of the mains supply being lost, the SW1 will automatically attempt to keep itself operating by braking (regenerating) a rotating motor. The rate of deceleration is set also by P-04, unless P-07 has been set to a non-zero value. In this case, the deceleration ramp rate set in P-07 is used.

In general, best performance is achieved when P-07 is somewhat longer than the normal braking time and is also improved when slip compensation is activated (whenever the motor rated speed is entered in P-10).

When **P-05 is set to 1**, coast-to-stop is selected. In this case, the SW1 output will be disabled as soon as the enable signal is removed, leaving the motor to coast down to zero in an uncontrolled fashion.

When **P-05 is set to 2**, the motor will be ramped down to zero similarly to the case above where P-05 = 0 whenever the drive enable signal is removed.

When the mains supply is removed, however, the drive will ramp the output down to zero at the rate defined in P-04 if P-07 = 0; otherwise at the rate defined in P-07. This allows the motor to be stopped

rapidly (a form of Emergency Stop), independently of the main deceleration ramp time, in the event of the mains supply being lost.

Maximum value: 2

Minimum value: 0

Default value: 0

P-06 - V/F characteristic select

This parameter defines the rate at which the voltage is applied to the motor as the output frequency increases. For many applications the required characteristic is linear (constant torque selected when P-06 = 0), but for fan and some pump applications, a significant energy saving can be achieved at lower speeds by selecting the variable torque setting (P-06 = 1).

Maximum value: 1

Minimum value: 0

Default value: 0

P-07 - Rapid deceleration ramp rate

The second deceleration ramp can be selected manually or automatically under certain conditions to effectively provide an independent, rapid stop facility that can be used in conjunction with an E-Stop. In most cases, this will be set to a lower value than the standard deceleration ramp rate in P-04.

When **P-07 = 0**, the second deceleration ramp function is disabled.

The second deceleration ramp is activated automatically when **P-05 = 0 or 2** and the mains supply is lost or removed. This ramp can also be activated manually by closing digital inputs 1 and 2 simultaneously when P-19 has been set to 5, 7 or 9. These inputs would normally be connected to a rapid stop button and could, for example, be linked with an E-Stop function.

Maximum value: 25s

Minimum value: 0.0s

Default value: 0.0s

P-08 - Motor rated current

The rated current of the motor to be connected to the SW1 (as stamped on the motor rating plate) should be entered into this parameter. This allows the SW1 to match its internal motor thermal protection (I x t protection) to the motor itself. This ensures that the drive will trip on motor overload (I.t-trP) before any thermal damage occurs in the motor.

Maximum value: rated current of the SW1

Minimum value: 0.25x rated current of the SW1

Default value: rated current of the SW1

P-09 - Motor rated frequency

The rated frequency of the motor to be connected to the SW1 (as stamped on the motor rating plate) should be entered into this parameter. This defines the frequency at which maximum (rated) output voltage is applied to the motor. Above this frequency, the voltage is held constant at this maximum value. At frequencies below the value entered in P-09, the output voltage varies in accordance with the setting of P-06 (V/F characteristic).

Note that the V/F curve can also be modified using parameters P-26 and P-29, allowing you to adapt the V/F curve to suit non-standard motors.

Maximum value: 1000Hz

Minimum value: 25Hz

Default value: 60Hz

P-10 - Motor rated speed

The rated speed of the motor (in rpm) to be connected to the SW1 (as stamped on the motor rating plate) should be entered into this parameter if it is required that the SW1 displays its speed in rpm. When a value (non-zero) has been entered into this parameter, the operating speed of the motor in rpm will be available on the display. The speed-related parameters (that is, P-01, P-02, P-20...P-23, P-27, P-28) will also be displayed in **rpm** once an rpm value has been entered in P-10.

In addition to permitting speed to be displayed in rpm, setting P-10 activates the **slip compensation**. In this case, the SW1 will attempt to maintain constant rotor speed in rpm under varying load conditions. This is done by internally measuring the load current and adjusting the applied stator frequency accordingly.

It is also possible to adjust the level of slip compensation applied by using the slip compensation adjustment factor (P-24).

If you want to have speed displayed in rpm without any slip compensation applied, the synchronous speed of the motor should be entered in P-10. This would be, for example, 3600rpm (2-pole), 1800rpm (4-pole), or 1200rpm (6-pole) for a 60Hz motor.

Maximum value: 60 x value of P-09 (Ex: 3600 rpm when P-09 = 60Hz)

Minimum value: 12 x value of P-09 (Ex: 720 rpm when P-09 = 60Hz)

Default value: 0

P-11 - Voltage boost level

The voltage boost parameter sets the level of voltage that is applied to the motor at zero output frequency (DC). This is used to ensure that the motor has sufficient starting torque to accelerate cleanly away from zero.

It may be necessary to increase the level of boost if operation at low speeds is required, or if the load connected to the motor needs a particularly large starting torque. If operation at very low speed for long periods of time is required, this parameter should be used with some caution, as large values of voltage boost can cause excessive heating in the motor at low speed. This is due to the fact that the fan connected to the rotor is virtually ineffective at low speed and little or no cooling of the motor results.

The effect of the voltage boost decreases linearly from the specified value at 0Hz to zero at half rated frequency (25Hz with a 50Hz motor). This approach gives a smoother transition from maximum to zero boost as output frequency increases.

Maximum value: 25% of rated motor voltage

Minimum value: 0

Default value: 3% of motor rated voltage

P-12 - Terminal / Keypad mode select

This parameter allows you to define whether the SW1 should be controlled from the User terminal connector (factory default setting) or from the push-buttons on the front of the keypad.

When **P-12 = 0**, terminal control mode is selected. The drive speed will be controlled using switches and / or a potentiometer. The function of the digital inputs can be defined using **P-19**.

When **P-12 = 1**, keypad mode is selected. The speed of the motor is controlled using the keys on the SW1 keypad. The **<START>** and **<STOP>** buttons will enable and disable the SW1 output respectively. When enabled, the speed of the SW1 can be ramped up and down using the **<UP>** and **<DOWN>** buttons. If remote keypad operation is required, **<START>**, **<STOP>**, **<UP>** and **<DOWN>** keys can be mounted on the front of a panel and connected electrically to the digital inputs (see *Application Note AN21* for more information). If the SW1 is stopped while running at a particular speed, it will return to that same speed when re-enabled (when the **<START>** button is pushed).

Note that the SW1 must have the hardware enable signal applied (digital input 1 closed) before keypad operation is possible.

When **P-12 = 1**, only forward (positive) speeds are possible and a reverse in direction cannot occur.

When **P-12 = 2**, the same functionality as above is achieved except for the fact that reverse operation **is** possible. In this case, the **<START>** button doubles up as a reverse “toggle” button. Each press of the **<START>** button will cause a reverse in direction. After stopping, the SW1 always starts in a positive speed direction. This ensures that there is no ambiguity about the direction in which the motor will start.

When **P-12 = 3**, terminal mode is enabled exactly as when **P-12 = 0**. In this case, however, Master mode (for Master / Follower operation) is also enabled. The SW1 will now transmit its speed reference signal continuously via the IR link. Any number of follower SW1s can be connected optically with the Master SW1 using the SWLink (see *Application Note AN24* for details)

Since the follower SW1s receive their speed reference via the optical IR communications port, these must be in keypad mode (**P-12 = 1** or **2**) to function correctly. Note that the speed of each follower SW1 can be scaled independently with respect to the Master SW1.

P-13 - Event and trip log

This parameter holds a record of the most recent four trips and / or events that have occurred. Each trip will be displayed in abbreviated text, with the most recent trip being displayed first (on entering the value of P-13).

Whenever a new trip occurs, it is entered at the top of the list and the other trips move down. The oldest trip is then removed from the trip log.

Note that if the most recent trip in the trip log is an “Under-voltage” trip, further Under-voltage trips will not be entered into the trip log. This is ensure that the trip log does not fill up with Under-voltage trips which naturally occur every time the SW1 is turned off.

See [Chapter 6](#) for detailed descriptions of the trip codes.

P-14 - Advanced access code

This parameter allows you to access the extended parameter set (P-15 to P-40). Access is allowed when the value entered into P-14 is equal to the value held in [P-37](#). In its factory default state, P-14 must be set to “101” in order to access the extended menu.

If access to the extended menu is to be denied (for example, where the parameters have been locked – see [P-38](#)), P-37 can be set to a user-defined value. Access to the extended menu will only be permitted when this user-defined value is entered into P-14.

Maximum value : 9999

Minimum value : 0

Default value : 0

5.4 Descriptions of advanced parameters

Notes:

- To restore factory default parameters, hold **<up>**, **<down>** and **<stop>** keys simultaneously for >1s. This also resets the access code, but does not affect the Hours run meter, which cannot be reset or changed.
- Pressing the **<up>** and **<down>** keys simultaneously in parameter edit mode resets the selected parameter number / value to zero (or the minimum value as defined by the limits for that parameter).

P-15 - Motor rated voltage

This parameter allows you to scale the applied motor voltage such that the value set in P-15 is reached when the output frequency reaches rated frequency (as set in P-09). It is therefore possible to run a 220V motor correctly when the SW1 has a 480V supply.

In addition, when P-15 has a non-zero value, voltage compensation is activated. This ensures that the output voltage is controlled correctly independent of supply voltage and/or in internal DC bus voltage which may vary significantly during deceleration.

When this parameter is set to zero, the output voltage varies with input voltage and during deceleration. The significant increase in motor voltage during deceleration will increase motor current and motor losses, which may mean that less (or no) braking resistors are needed.

Maximum value: 500V

Minimum value: 40V

Default value: 0 (disabled) for 230V SW1s, 460V for 480V SW1s

P-16 - Analog input format (V / mA)

This parameter allows you to configure the analog input to suit the format of the signal connected to the analog input. The following formats are supported :

Voltage 0..10V, 10..0V, -10..10V

Current 4..20mA, 0..20mA, 20..4mA

When configured for one of the voltage input formats, the analog input accepts bipolar input voltages in the range -10V..10V. When set to 0..10V or 10..0V, all negative voltages will give zero speed. When set to -10..10V, all negative voltages will result in the drive running in reverse, where the speed is proportional to the magnitude of the input voltage.

All current input formats are unipolar. When 4..20mA or 20..4mA is selected, the SW1 will automatically trip when the input current falls **below 2mA**. This is especially important for the inverse (20..4mA) setting where the drive would otherwise give maximum output speed if the current input was to be interrupted.

You can switch the analog input format using **digital input 3** when **P-19 = 0**. A voltage input format is selected when the input is open; otherwise, a current input format is selected. This allows switching between a local (voltage) signal and a remote (current) signal.

P-17 - Effective switching frequency

This parameter allows you to select the drive output switching frequency to accommodate different application requirements.

All 480V products are shipped with the effective output switching frequency set to **8kHz**. This minimizes the thermal losses in the SW1, which therefore runs cooler. When operating at a particular switching frequency, there will be an associated acoustic noise produced by the motor at that particular switching frequency. In most industrial applications (480V supplies), this is of little consequence as background noise is much greater.

Domestic (220V) applications, on the other hand, tend to be in quieter environments where acoustic noise level is important. For this reason, all 220V SW1s are set to **16kHz** as a factory default.

P-18 - Relay output function

This parameter allows you to select under what operating conditions the output user relay contacts are closed. The following settings are available:

- P-18 = 0:** Relay contacts closed when drive output is enabled
- P-18 = 1:** Relay contacts closed when drive is healthy (no trip)
- P-18 = 2:** Relay contacts closed when the output frequency is within 0.25Hz of the target (requested) frequency.
- P-18 = 3:** Relay contacts closed when the output frequency is greater than “zero frequency” (**5% x P-09**; 5% of base frequency)
- P-18 = 4:** Relay contacts closed when the output frequency reaches the maximum (**P-01**) frequency.
- P-18 = 5:** Relay contacts closed when the motor output current is greater than the continuous rated current (as specified in **P-08**)

Default value: 1 (drive healthy)

P-19 - Digital inputs function select

The functionality of the digital inputs within the SW1 is user-programmable, allowing you to select the functions required for the application.

Options include: selection between preset speeds, analog input (voltage / current), external thermistor input, forward / reverse, push-button operation.

Table 5-1 defines the functions of the digital inputs depending on the value of parameter P-19 (Digital input function select).

P-19	Digi input 1 function	Digi input 2 function	Digi input 3 function
0	Open : Stop (Disable) Closed : Run (Enable)	Open : Analog input Closed : Speed Preset 1	Volts / Current analog input
1	Open : Stop (Disable) Closed : Run (Enable)	Open : Analog input Closed : Speed Preset 1/2 (Digi input 3 selects)	Open : Speed Preset 1 Closed : Speed Preset 2
2	Open : Stop (Disable) Closed : Run (Enable)	Digital input 2 : open \\ Digital input 3 : open / Digital input 3 : open \\ Digital input 2 : closed / Digital input 3 : closed \\ Digital input 2 : open / Digital input 3 : closed \\ Digital input 2 : closed /	➔ Selects Speed Preset 1 ➔ Selects Speed Preset 2 ➔ Selects Speed Preset 3 ➔ Selects Speed Preset 4
3	Open : Stop (Disable) Closed : Run (Enable)	External trip input Open : trip, Closed : OK	Open : Analog Input Closed : Speed Preset 1
4	Open : Stop (Disable) Closed : Run (Enable)	Open : Forward Closed : Reverse	Open : Analog Input Closed : Speed Preset 1
5	Open : Stop (Disable) Closed : Fwd Enable	Open : Stop (Disable) Closed : Reverse Enable	Open : Analog Input Closed : Speed Preset 1
6	Open : Stop (Disable) Closed : Run (Enable)	Open : Forward Closed : Reverse	External trip input Open : trip, Closed : OK
7	Open : Stop (Disable) Closed : Fwd Enable	Open : Stop (Disable) Closed : Reverse Enable	External trip input Open : trip, Closed : OK
8	Open : Stop (Disable) Closed : Run (Enable)	Open : Forward Closed : Reverse	Open : Speed Preset 1 Closed : Speed Preset 2
9	Open : Stop (Disable) Closed : Fwd Enable	Open : Stop (Disable) Closed : Reverse Enable	Open : Speed Preset 1 Closed : Speed Preset 2
10	Normally Open (N.O.) Momentarily Close to run	Normally Closed (N.C.) Momentarily Open to stop	Open : Analog Input Closed : Speed Preset 1
11	Normally Open (N.O.) Push to run forwards	Normally Closed (N.C.) Momentarily Open to stop	Normally Open (N.O.) Push to run reverse
12	Open : Stop (Disable) Closed : Fwd Enable	Closed to run Open to activate fast stop	Open : Analog Input Closed : Speed Preset 1

Table 5-1.

Notes:

- Forward speed is defined by clockwise rotation as viewed looking towards the motor shaft.
- If **P-19 = 0 and digital input 3 = 0**, the analog input will be in volts (0-10V) irrespective of the setting in P-16. If **digital input 3 = 1**, the current input format will be 4-20mA unless P-16 is set to either 0-20mA or 20..4mA. This allows the input format to be switched between voltage (local) and current (remote) formats. The dual analog input option card provides a facility for connecting the second analog input.
- If **P-19 <> 0**, the analog input format is defined by **P-16**: (0-10V / 4-20mA / 0-20mA / 20-4mA / 10..0V / -10V..10V).
- If **P-19 = 5, 7 or 9**, the fail-safe "wire-break" mode is supported, where either digital input 1 or 2 will be active for forward and reverse operation, respectively. In this case, a break in the wire will always result in the drive being disabled and the motor coming to zero.

Default setting: 0

P-20 ... P-23 - Preset / Jog speeds 1 ... 4

Parameters P-20 – P-23 permit you to define up to 4 individual preset speeds. The preset speeds are selected using the programmable digital inputs. The preset speeds can be set to any value within the range P-02 (minimum value) to P-01 (maximum value).

Maximum value: P-01

Minimum value: P-02

Default value: 60.0Hz for P-20, 0.0Hz for P-21 ... P-23

P-24 - Slip compensation correction factor

When the rated speed of the motor connected to the SW1 is entered in P-10, slip compensation is automatically activated. This means that the SW1 will attempt to maintain constant shaft speed independent of the applied mechanical load. This calculation assumes particular motor characteristics which may vary from motor to motor. This parameter allows you to trim the level of slip compensation applied. When set to the factory default value (100%), there is no change to the slip compensation applied.

Maximum value 250%

Minimum value 20%

Default value: 100%

P-25 - Analog output function

The function of the analog output can be controlled using this parameter. The following options are available :

Analog output mode

P-25 = 0: Motor Speed. 0V = zero speed, +10V = maximum speed (P-01)

P-25 = 1: Motor Current. +10V = 200% of the motor rated current (P-08)

Digital output mode

P-25 = 2: +5V when drive enabled, 0V when disabled

P-25 = 3: +5V when motor at set speed, 0V otherwise

Digital output mode can be used in conjunction with the optional 2nd relay output module. This 2nd relay is driven by the digital output and effectively adds an independent relay output to that within the SW1 (controlled from P-18).

Default value: 0 (analog speed output)

P-26, P-29 - V/F characteristic adjustment

The Voltage - Frequency characteristic defines the level of voltage applied to the motor at any given frequency. Depending on the setting of P-06, this will have either:

- a linear characteristic (where voltage increases linearly with frequency – P-06 = 0) or
- a quadratic characteristic (where voltage increases in proportion to (frequency)² – P-06 = 1).

First, the above characteristic will be modified by the setting of P-11 (voltage boost level). Parameters P-26 and P-29 then give an extra level of adaptation, allowing you to further modify the V/F characteristic, if required.

Parameter P-29 can be set to any frequency between 0 and the base frequency (P-09) and represents the frequency at which the percentage adjustment level set in P-26 is applied.

Note that the voltage at any particular frequency can be increased or decreased to suit the needs of the application.

When **P-29 = 0**, this function is disabled.

P-26	P-29
Maximum value: 250%	Maximum value: P-09
Minimum value: 20%	Minimum value: 0 Hz
Default value: 100%	Default value: 0 Hz

P-27, P-28 - Skip frequency / Skip frequency band

The skip frequency parameters are used to set up a band of frequencies through which the drive output frequency may pass, but never stop. This is used typically to prevent continuous operation close to any frequency at which mechanical resonances may occur. Such resonances may simply cause excessive acoustic noise or may in some cases cause mechanical stresses that could lead to mechanical failure.

Parameter P-27 specifies the center point of the skip frequency band; P-28 specifies the width of that band. For example :

P-27 = 30Hz, P-28 = 10Hz

This will give a skip frequency band between 25Hz and 35Hz, centered on 30Hz. If the analog speed reference then requests a speed within these limits, the speed will remain at the **nearest limit**. When the output frequency ramps between these two limits, it will do so at the ramp rates specified in [P-03](#) and [P-04](#).

In the event of the output / motor running at negative speeds, the skip frequency band will have exactly the same effect as in the positive direction..

P-27	P-28
Maximum value: P-01	Maximum value: P-01
Minimum value: 0	Minimum value: 0
Default value: 0	Default value: 0

P-30 - Start mode / Auto reset select

This parameter allows you to define the start-up mode of the SW1 and operates in conjunction with the hardware enable signal applied between terminals 1 and 2.

Possible settings are :

- | | |
|----------------------------|--|
| Line Start Lock-out | Edge run – requires the run signal to be applied <i>after</i> a trip or power-down to start |
| Auto-0 | Auto-run – enables whenever a run signal is present (assuming no trip) |
| Auto-1 to 4 | Same as Auto-0, except that the SW1 will attempt to auto restart after a trip. The number of re-start Attempts is given by the number after the "Auto-". The re-start counter is reset after a power down. |

In the factory default setting (Auto-run), the SW1 will start and run whenever terminals 1 and 2 are linked, provided there is no trip condition.

Line Start Lock-out may be used where the drive **should not** start automatically on power up if the run switch is closed. In this case, the run switch must be opened and then re-closed before the drive will start. The same rule applies after clearing / re-setting a trip condition.

If the application requires that the drive attempts to re-start after a trip condition, parameter P-30 can be set to **Auto-1 ... Auto-4**, in which case the drive will attempt to clear the trip and re-start between 1 and 4 times after a trip. After this number of re-starts have been attempted, the drive will remain in a tripped state. Typically, an operator would investigate the cause of the trips at this stage. In each of these cases, a delay of 20s will elapse after a trip before the SW1 attempts a re-start.

Default setting : Auto-0 (enables whenever a run signal is present)

P-31, P-32, P-33 - DC injection braking control

DC injection braking is typically applied just before the output of the SW1 is disabled (when a stop command has been issued) to ensure that the motor has come to standstill. This is often used in conjunction with a mechanical brake which can be activated using the on-board relay (configured using P-18). The relay contacts will only open when the SW1 disables its output (**P-18 = 0**), that is, after DC injection braking has been applied.

To accommodate different motors and inertias, the level of DC injection braking (voltage) can be set using P-31 and the duration in seconds in P-32.

Note that DC injection braking is only applied after a stop signal has been issued (drive enable removed) and the output has ramped to zero. If coast to stop has been selected (**P-05 = 1**), DC injection braking will not be applied.

In some applications (typically fans and pumps) a motor / load may freewheel when not being driven by the SW1 (due to air / fluid flow). In these cases, it is beneficial to brake the motor to a standstill before attempting to bring it up to the operational speed. This prevents possible over-current trips that might otherwise occur. In such cases, the motor can be also braked to zero using DC injection braking. In this case, it must be applied after an enable signal has been applied prior to the output ramping up from zero.

P-34 - External braking resistor selection

If an external braking resistor is to be used with the SW1 to enable high inertia loads to be stopped rapidly, P-34 must be set accordingly. The following options are available :

P-34 = 0 Internal braking control disabled. Braking resistor has no effect.

P-34 = 1 Internal braking control activated. In addition, the internal power dissipation monitor is activated which ensures that the thermal limit of the externally connected braking resistor is not exceeded.

This monitor assumes that one or more of the drive's braking resistors is connected, where the thermal limits are known.

If the power dissipation limit is exceeded, the SW1 will trip displaying the message "OL-br" (Overload brake resistor).

In the event of other (non- TB Wood's) resistors being used, P-34 should be set to **2**.

P-34 = 2 Internal braking control activated. The internal power dissipation monitor is disabled. This means that it is now possible to overload the external braking resistor and other protection methods should be considered. This setting should be used if, for example, high power braking resistors are connected.

Default setting: 0 (braking resistor control disabled)

P-35 - Speed reference input scaling factor

This parameter is used to scale either the analog speed reference or the digital speed reference, depending on whether the SW1 is in terminal or keypad mode.

When the SW1 is in terminal mode (**P-12 = 0 or 3**), this parameter is used to scale the analog input so that a 0...10V signal on the input controls the output speed linearly between the minimum (**P-02**) and maximum (**P-01**) speed limits. The adjustment of P-35 to match the operating range P-02 to P-01 is done automatically by the SW1 whenever P-01 or P-02 is changed.

When the SW1 is in keypad mode (**P-12 = 1 or 2**), P-35 will typically have a value of 100%, regardless of the settings of P-01 and P-02. If the SW1 is being controlled from its own keypad, or via keys connected to the input terminal strip (remote push-button control), there will normally be no need to change P-35.

In Master / Follower mode, all follower drives must be in the keypad mode (**P-12 = 1 or 2**). If the relative speeds of the Master and various follower drives need to be set independently to suit the application (speed scaling), this can be done by setting P-35 to the required value in each of the follower drives. Any follower drive can be set to run at between 20% and 500% of the Master drive.

Note that the acceleration ramp times should be scaled by the same factor as the Master / Follower speed. For example, if a follower drive runs to 2x the speed of the Master drive, its accel / decel ramp times should be set to 0.5x those of the Master. This ensures accurate ramp rate following in addition to end speed following.

Master / Follower mode uses **SWLink** – a polymer fiber interconnect system allowing multiple SW1s to communicate optically.

Maximum value: 500%

Minimum value: 1%

Default setting: 100%

P-36 - Serial communications drive address

All communications between the SW1 and other peripheral products are carried out via the optical IrDA interface. To allow multiple drive communications networks (where multiple SW1s are connected to the same optical link), it is necessary for each drive to have its own unique drive address.

The drive address can be set to any value between **1 and 63**, allowing upto 63 discrete drives to be connected on the same optical network. When any SW1 receives a valid telegram (message) via the optical interface, it will only respond to the command **if that telegram contains its own drive address**. In this way, any one drive from the entire group of 63 can be picked out, which will then respond in the requested manner.

If **P-36 = 0**, all communications are disabled.

Maximum value: 63

Minimum value: 0

Default setting: 1

P-37 - Advanced menu access code definition

Parameter P-37 allows users to specify their own extended menu access code. Access to the extended menu (P-15 to P-40) is only permitted when the value entered in P-14 equals that stored in P-37. In this way, you would be able to change the code from the standard value of "101" to any desired value. This feature is often used in conjunction with P-38 (parameter write access).

Maximum value: 9999

Minimum value: 0

Default setting: 101

P-38 - Parameter access control

This parameter allows you to specify what type of access to parameters is to be permitted and can be used to lock all parameter write (change) operations. The following settings are available :

- P-38 = 0** All parameters can be accessed and changed. All changes will be saved in permanent memory and will apply even after a power down. The parameter save-to-memory process is automatic.
- P-38 = 1** All parameters can be accessed and changed. All changes will be saved in temporary memory and functional until the SW1 is powered down. After the next power up, the parameter settings will be extracted from permanent memory; all changes made with P-38 = 1 will be lost. This setting may be used to test experimental settings without risk of losing a known set of parameter settings.
- P-38 = 2** All parameters can be accessed for read purposes but changes are not permitted. This ensures that a set of working parameters is not changed by unauthorized users. If **P-38 has been set to 2**, the user can then specify an extended access code in **P-37**. Only with this code can the extended menu be accessed, and parameter P-38 changed to 1 or 2.

Maximum value: 2

Minimum value: 0

Default setting: 0; all changes permitted and changes automatically saved)

P-39 - Hours run indicator

This is a read-only parameter indicating the number of hours that the SW1 has been running. It is not re-settable and therefore holds useful information on the lifetime of the SW1 and / or the equipment that it is driving.

P-40 - Drive type identifier / software version

This read-only parameter allows you to determine the SW1 voltage and power rating in addition to the software version.

A typical display indicating the voltage/power rating would be, for example, **H3 7.5**, indicating a **460V, 3-phase 7.5kW rating**.

Similarly, a display of **L1 0.75** would indicate a rating of **230V, 1phase 1.0 HP**.

The software version (Ex: **1.05**) is displayed if you press the **<UP>** key on the SW1 keypad.

NOTES

6. FAULT CODES, DRIVE STATUS AND DIAGNOSTICS

The following operational status information for the drive is displayed:

Drive OK, disabled:	Stop
Drive running:	Output frequency / speed of drive, or motor current
Fault / trip:	Fault mnemonic as defined in Table 6-1 .

[Table 6-1](#) on the next page shows which mnemonics are displayed under certain conditions, and their meanings.

E-trAC SW1 Microdrive User's Manual

Mnemonic	Description
StoP	Drive power stage disabled. This message is displayed when drive is stopped and no faults are present. The drive is ready for normal operation.
P-deF	Default parameters loaded. This message is displayed when the user invokes the command to load the factory default parameters.
O-I	Over-current on drive output. If this occurs during normal operation, it may indicate an excessive acceleration rate or that the kW rating of the motor is greater than that of the drive.
O-Uolt	Over-voltage on DC bus. This may occur if deceleration rate is too rapid. Normally, this can be resolved by fitting an external braking resistor(s) to the SW1 power terminals. Ensure that P-34 is set to 1 or 2 to enable the SW1 internal braking circuit.
U-Uolt	Under-voltage on DC bus. This indicates that the mains supply voltage is below the minimum limit. This code occurs each time the supply to the drive is turned off.
OL-br	Brake resistor thermal overload. When P-34 = 1 , the SW1 monitors the power dissipation in braking resistor(s) connected to the SW1. If the allowed internal limit is exceeded, the SW1 will trip with this fault message. The deceleration ramp time must be reduced or more braking resistors must be added. When multiple brake resistors are used, the minimum braking resistor ohm value must be observed.
OI-b	Brake resistor short circuit. This usually indicates a low resistance or short circuit across the braking resistor.
I.t-trP	Motor thermal overload. When the motor current level exceeds 100% of the motor current value entered in P-08 , the SW1 monitors the level and duration of the overload. Depending on the overload level, the SW1 will trip with this message after a certain time period. Typically, the SW1 delivers 150% of the current in P-08 for 1 minute.
th-Flt	Faulty thermistor on heatsink. This is not a user-serviceable part. Contact an authorized SW1 distributor to correct this fault.
EE-F	EEPROM checksum failure. Parameters not saved, defaults reloaded. This is not a user-serviceable part. Contact an authorized SW1 distributor to correct this fault.
PS-Flt	Internal power stage fault, indicating an over-current or a thermal overload within the power switching module. If this fault occurs as soon as the SW1 is enabled, it may indicate a failed power module. In this case, contact an authorized SW1 distributor to correct this fault.
O-t	Heatsink over temperature. This generally indicates that the SW1 is operating at too high a switching frequency for the operating load and / or environmental temperature. Reduce the switching frequency or improve airflow / cooling to overcome this problem.
E-trP	External trip. This trip message occurs when one of the digital inputs has been configured (using P-19) to support an external trip. Depending on the setting of P-19 , this may be Digital input 2 or 3. Both of these inputs are suitable for thermistor connection (type PT100). When this input is shorted to 0V (or < 2k), no trip will occur. When the resistance increases beyond 5k, the SW1 will trip on E-trP.
SC-trP	Serial communications trip. Communication between the Master and Follower SW1s in Master / Follower mode has been interrupted. Ensure that the Optical Link is intact.
Iin-F	The current level on the analog input has fallen below 2mA when the input is configured for 4..20mA operation. The current should remain within range.

Table 6-1.

Overcurrent

If the drive is required to accelerate or decelerate at a rate that would require >150%, the increased current level will be limited to 175% drive current by hardware. This may result in the motor acceleration or deceleration rate not being achieved.

If excessive acceleration or deceleration is selected (very low ramp rates), it is possible that the drive may trip on overcurrent (O-I).

When the drive is delivering >100% motor current, an **I.t integral** will result in the drive tripping, should the permitted time limit be exceeded. This will occur after 1 minute at 150%.

NOTES

7. SW1 MICRODRIVE OPTIONS

SDIN1 / SDIN2 - DIN Rail mounting kits for the Size 1 and 2 models only. These mounting brackets attach to the drive to allow standard DIN rail mounting. DIN rail mounting permits quick and simple mechanical installation.

SPC01 - Dual Analog Input – This option allows the connection of two analog signals to the S-Series drive. These inputs can be used simultaneously or switched between in an Auto/Manual mode using the D3 input. Both analog inputs have a 10-bit resolution.

SPC02 - Dual Relay Output – This option provides a second digital relay output from the S-Series drive. The analog output is converted to a Form A relay output rated for 230V, 5 Amps, and can be configured using [parameter 18](#).

SWPC03 - PI Control – An option board that provides a setpoint(PI) controller function to the S-series drives. With adjustable P and I gain controls, the option makes it easy to configure and run basic applications. The setpoint can be from an on-board potentiometer, or analog inputs at either 0-10Vdc or 4-20 mA. The feedback signal can also be either 0-10Vdc or 4-20 mA.

SW1RES01 – Dynamic braking resistor for use on SW1 drives with a DB transistor installed. The resistor can be mounted to the side of the heatsink with the supplied hardware. The resistor is designed to provide 200W continuous braking through its 50 Ohms resistance. If additional braking is required, a second resistor can be added to the drive to maximize the braking capacity of the drive.

SWPORT kit - Remote keypad with IP54/NEMA 12 mounting. The connection can be made through a fiber-optic link or using the IrDA port. The keypad adds PI control, one analog input, and one relay output. A 24V-power supply for powering the keypad and SWRS485 option board is also included. Typical mounting is a maximum of 1 meter from the drive.

SWRP01 – Remote keypad adds PI control, one analog input, and one relay output. A separate 24V-power supply is needed to power the unit.

SWRS232 - RS232 option board – A PC board used to allow the interface of a PC to the SW1 drive. The board includes a 9-pin D shell connector for connection to the PC and an IrDA kit to connect the board to the IR port on the drive. The 11-pin terminals are straight-through connections and have no effect on the serial port. Multiple drives can be connected via this board using the SWLINK kit.

SWRS485 - RS485 option board - A PC board used to allow the interface of a PC or PLC to the SW1 drive. The standard protocol, Modbus RTU, allows up to 63 drives to be connected on a single link. The board includes a 6-pin terminal strip for connection of either 2- or 4-wire RS485. An IrDA kit to connect the board to the IR port on the drive is also included. The 11-pin terminals are straight through connections and have no effect on the serial port. Multiple drives can be connected via this board using the SWLINK kit.

SWLINK – This option provides the Master / Follower connections to SW1 drives. The kit includes adapters for replacing the standard IrDA window on each drive, one for the Master (single connector) and one for the Follower (a 2-connector window). One kit will handle a Master and one Follower. For multiple followers, multiple SWLINK kits are required.

NOTES

USA SALES

TB Wood's Incorporated Headquarters

440 North Fifth Avenue
Chambersburg, Pennsylvania 17201-1778
Telephone: 888-TBWOODS or 717-264-7161
FAX: 717-264-6420
Website: www.tbwoods.com

TB Wood's Chattanooga Operations

521 Airport Road
Chattanooga, TN 37421
Telephone: 800-437-3311 or
423-893-7654
FAX: 423-894-0495

TB Wood's San Marcos

2000 Clovis Barker Road
San Marcos, TX 78666
Telephone: 800-796-5513 or
512-353-4000
FAX: 512-353-4017

INTERNATIONAL SALES

Canada

T.B. Wood's Canada Ltd.
750 Douro Street
Stratford, Ontario, Canada N5A 6V6
Telephone: 519-271-5380
FAX: 519-271-3094

Germany

Berges electronic GmbH
Industriestrasse 13
D-51709 Marienheide, Germany
Telephone: 49-2264-17-0
FAX: 49-2264-17-126

India

TB Wood's (India) Private Limited
No. 27A, 2nd Cross
Electronic City, Hosur Road
Bangalore, 561 229 India
Telephone: 91-80-8520-123
FAX: 91-80-8520-124

Italy

Berges electronic s.r.l
Via Zona Industriale, 11
I-39025 Naturno, Italy
Telephone: 39-0473-67-1911
FAX: 39-0473-67-1909

Mexico

Industrial Blaju S.A. de C.V.
Oriente 237 No. 171
Colonia Agricola Oriental
08500 México, D.F. México
Telephone: 52-55-55-58-16-20
FAX: 52-55-57-56-06-74

Other TB Wood's Locations

Edmonton, Canada

Montreal, Canada

Mt. Pleasant, Michigan

Reno, Nevada

Scotland, Pennsylvania



TB Wood's

Authorized Distributors Worldwide