



# ELECTRONIC BYPASS CONTROLLER

## INSTRUCTION MANUAL START-UP GUIDE

Saftronics, Inc.  
5580 Enterprise Parkway  
Fort Myers, FL 33905  
Phone: (239) 693-7200  
Fax: (239) 693-2431  
© Copyright Saftronics, Inc. 2004

Manual Part Number 027-2175  
Rev. 08/2005

## **WARNING**

### **SAFETY AND PRECAUTIONS**

1. Read this manual in its entirety before installing or operating the Electronic bypass. This manual applies to systems with the Safronics GP10 inverter, C10 inverter and control board part number 1067144 installed and is not intended to be used with any other products.
2. Do not connect or disconnect wiring, or perform signal checks while the power supply is turned ON
3. The internal capacitor of the installed inverter may be charged even after the power supply has been turned OFF. To prevent electrical shock, disconnect all power before servicing the Electronic bypass. Please wait 5 minutes after the power supply has been disconnected and all LED's have been extinguished.
4. Do not perform a voltage withstand test on the Electronic bypass or the installed VFD. This electronic equipment uses semi conductors and is vulnerable to high voltage. Severe damage to the equipment may occur.
5. Do not remove the digital operator from the inverter unless the power supply has been turned OFF. Never touch the printed control board while the power supply is turned on.
6. The Electronic bypass is suitable for use on a circuit capable of delivering not more than 100,000 RMS symmetrical amperes, 480 Volts maximum (460 Volt Class units), 240 volts maximum (230 Volt class units).
7. Several printed circuit boards are installed in the Electronic bypass. Damage may occur due to ESD Electrostatic Discharge. DO NOT handle any components without following proper ESD precautions.

*Failure to observe these and other precautions highlighted in this manual will expose the user to high voltages, resulting in equipment damage, serious injury or death.*

Printed in June 2005. The information contained within this document is proprietary to Safronics, Inc. and may not be copied, reproduced or transmitted to other parties without the expressed written consent of Safronics Inc.

No patent liability is assumed with respect to the use of information contained herein. Moreover, because Safronics is constantly improving its high quality products, the information contained in the manual is subject to change without notice. Every precaution has been taken in the preparation of the manual. Nevertheless, Safronics assumes no responsibility for errors or omissions. Neither is liability assumed for damages resulting from the use of the information contained in this publication.

---

---

## TABLE OF CONTENTS

<b>SAFETY AND PRECAUTIONS</b> .....	<b>3</b>
<b>CHAPTER 1 - INTRODUCTION</b> .....	<b>6</b>
<b>CHAPTER 2 - INSTALLATION INSTRUCTIONS</b> .....	<b>7</b>
2.1 Receiving .....	7
2.2 Nameplate Information .....	7
2.3 Part Number Identification: FPC5010e and FPC10 .....	9
2.4 Mounting Clearance .....	11
2.5 Wiring and Precautions .....	12
2.5.1 General .....	12
2.5.2 Input Wiring .....	12
2.5.3 Output Wiring .....	13
2.5.4 Control Circuit Wiring (FPC5010e) .....	15
2.5.4.1 Analog Output .....	15
2.5.4.2 Digital Input .....	15
2.5.4.3 Digital / Relay Outputs .....	15
2.5.4.4 Internal Control Wire Connections .....	16
2.5.4.5 Distance between FPC5010e and Motor .....	16
2.5.5 Control Circuit Wiring (FPC10) .....	17
2.5.5.1 Analog Output .....	17
2.5.5.2 Digital Input .....	17
2.5.5.3 Digital / Relay Outputs .....	17
2.5.5.4 Internal Control Wire Connections .....	18
2.5.5.5 Distance between FPC10 and Motor .....	18
2.5.6 Grounding .....	19
2.6 Inspection .....	19
2.7 Checking Motor Rotation .....	19
2.7.1 Check #1: Rotation on VFD power .....	19
2.7.2 Check #2: Rotation on Bypass power .....	20
<b>CHAPTER 3 - OVERVIEW OF THE ELECTRONIC BYPASS</b> .....	<b>21</b>
3.1 Control Board .....	21
3.2 Keypad Function Summary .....	21
3.3 Using the Bypass Configuration Switches Electronic Bypass .....	23
3.4 Using the Additional Customer Inputs .....	24
3.5 Alarm Displays .....	24
3.6 Failure and Power Off Conditions .....	24
3.7 Control Modes of the Electronic Bypass .....	25

3.7.1 TEST mode .....	25
3.7.2 VFD mode .....	25
3.7.3 BYPASS mode .....	25
3.7.4 HAND mode .....	25
3.7.5 AUTO mode .....	26
3.8 Bypass Modes of the Electronic Bypass .....	26
3.8.1 MANUAL Bypass .....	26
3.8.2 AUTOMATIC Bypass on VFD Fault .....	27
3.8.3. A) EMERGENCY Bypass .....	27
3.8.3. B) EMERGENCY VFD .....	27
<b>CHAPTER 4 - PROGRAMMING .....</b>	<b>28</b>
4.1 VFD / GP10 Required Programming .....	28
4.2 VFD / C10 Required Programming .....	28
4.3 VFD / GP10 Recommended Programming .....	29
4.4 VFD / C10 Recommended Programming .....	30
<b>CHAPTER 5 - OPERATION .....</b>	<b>31</b>
5.1 Keypad Operation .....	32
5.1.1 VFD Keypad .....	32
5.1.2 HVAC Keypad .....	32
5.1.3 Electronic Bypass Keypad Layout .....	33
5.1.4 System Status LED's .....	33
5.1.5 Hand / OFF / Auto Buttons .....	34
5.1.6 Test / VFD / Bypass buttons .....	34
5.1.7 HVAC specific faults LED display .....	34
5.2 Starting Operation .....	35
5.3 Ending Operation .....	35
<b>CHAPTER 6 - ALARM &amp; FAULTS .....</b>	<b>36</b>
6.1 HVAC Keypad Alarms and Faults .....	36
6.2 VFD Alarms and Faults .....	37
<b>CHAPTER 7 - APPENDIX .....</b>	<b>38</b>
7.1 Specifications .....	38
7.1.1 Electronic Bypass .....	38
7.1.2 GP10 Specifications .....	39
7.1.3 C10 Specifications .....	39
7.2 Layout and Dimensions .....	39
7.3 Maintenance & Inspection .....	40
7.4 Start-up Checklist .....	41
<b>CHAPTER 8 - SCHEMATIC .....</b>	<b>42</b>
<b>START-UP CHECK LIST .....</b>	<b>43</b>

## CHAPTER 1 - INTRODUCTION

Thank you for purchasing the Safronics Electronic bypass Electronic bypass HVAC controller. This manual provides information concerning the installation, wiring and general startup procedures for both the FPC5010e and the FPC10 lines of electronically controlled three contactor bypass packages. The Electronic bypass is a complete integrated HVAC control system, that employs the latest technology in Variable Frequency Drives and incorporates a dedicated micro-processor based controller for HVAC applications. The Electronic bypass controller uses a dedicated HVAC keypad that clearly shows system operating conditions. The Electronic bypass is designed for ease of installation and start-up.

Please follow the instruction manuals guidelines for proper installation and programming of the Electronic bypass controller.

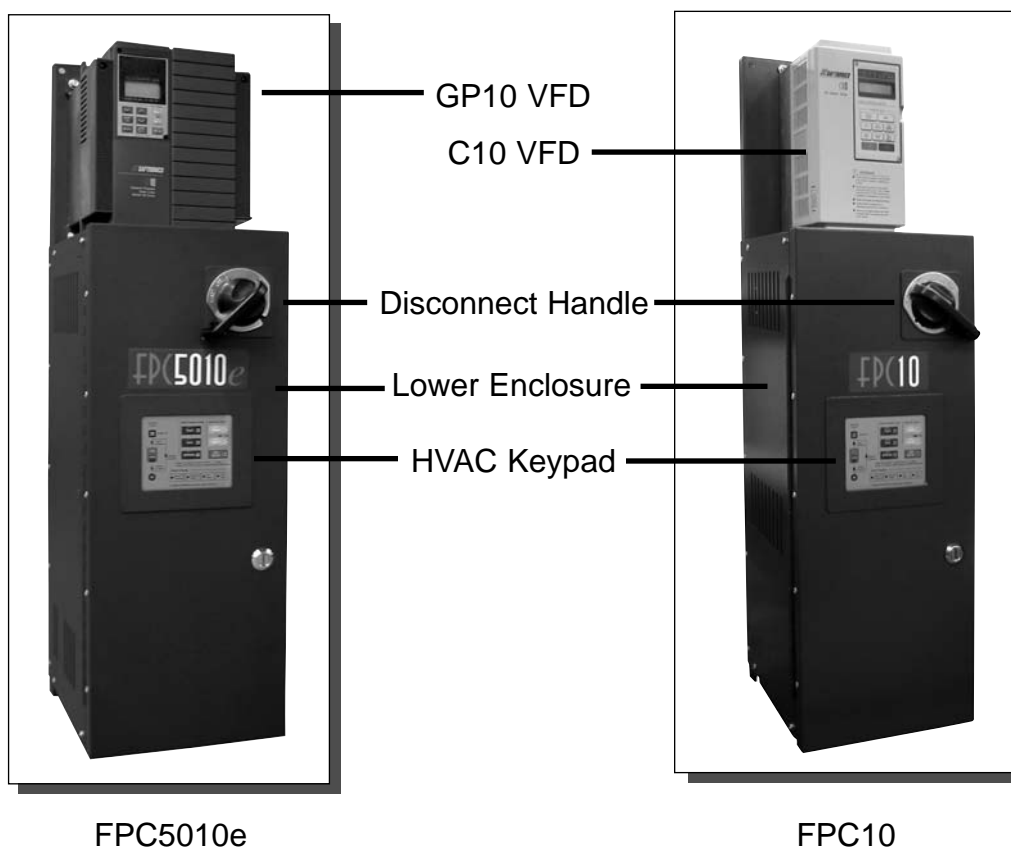

## CHAPTER 2 - INSTALLATION INSTRUCTIONS

### 2.1 RECEIVING

After unpacking the Electronic bypass:

- ✓ Verify that the part numbers on the package match the numbers on your purchase order, packing slip or tagging information.
- ✓ Check the unit for physical damage which may have occurred during shipping. If any part of the package is missing or damaged. Notify the carrier and your Safronics representative immediately.
- ✓ Verify that all internal hardware (i.e. components, screws, etc.) are properly seated and fastened securely.



### 2.2 NAMEPLATE INFORMATION

The Electronic bypass units have two nameplates for unit identification. The main label is located on the inside cover of the enclosure door. This nameplate supplies information on the entire unit. The second nameplate is located on the side of the inverter unit. This nameplate contains information related to the inverter only. The nameplate information should be recorded and kept in a safe location. This information is required for any service or repair work.

#### **Black Label Information**

5580 Enterprise Parkway, Fort Myers FL 33905 239-639-7200		
Part Number	<input type="text"/>	
	INPUT	OUTPUT
Frequency	<input type="text"/>	<input type="text"/>
Voltage	<input type="text"/>	<input type="text"/>
Amperes	<input type="text"/>	<input type="text"/>
Serial #	<input type="text"/>	

**Drive Label information**



			
Model No. Serial No.		 	
Input	VT	Output	CT
Volts		HP	
Amps		Volts	
Freq(Hz)		Freq. Range (Hz)	
Phase(s)		Amps	
		Overload	
NEMA Enclosure Type: Instruction Book			Made in Mexico

**Ratings Nameplate**

Serial Number: 01 10 - 00012M0001

— Production lot serial number  
 — Production week: Fiscal week (01 to 53)  
 — Production year: Last two digits of year (00 = 2000)

**C10 Nameplate**

Model: C102001-1	<b>Inverter Model</b>
AC Input: 3PH 200-230V 50-60 Hz	<b>Inverter Specification</b>
AC Output: 3PH 0-230V Amps: 6.4A	<b>Inverter Model</b>
  	

C10 2 002 - 1

C10 Series  
 Rated Voltage  
 2: 208 ~ 230V  
 4: 380 ~ 460V  
 NEMA 1  
 Motor Capacity (HP)

### 2.3 PART NUMBER IDENTIFICATION: FPC5010E

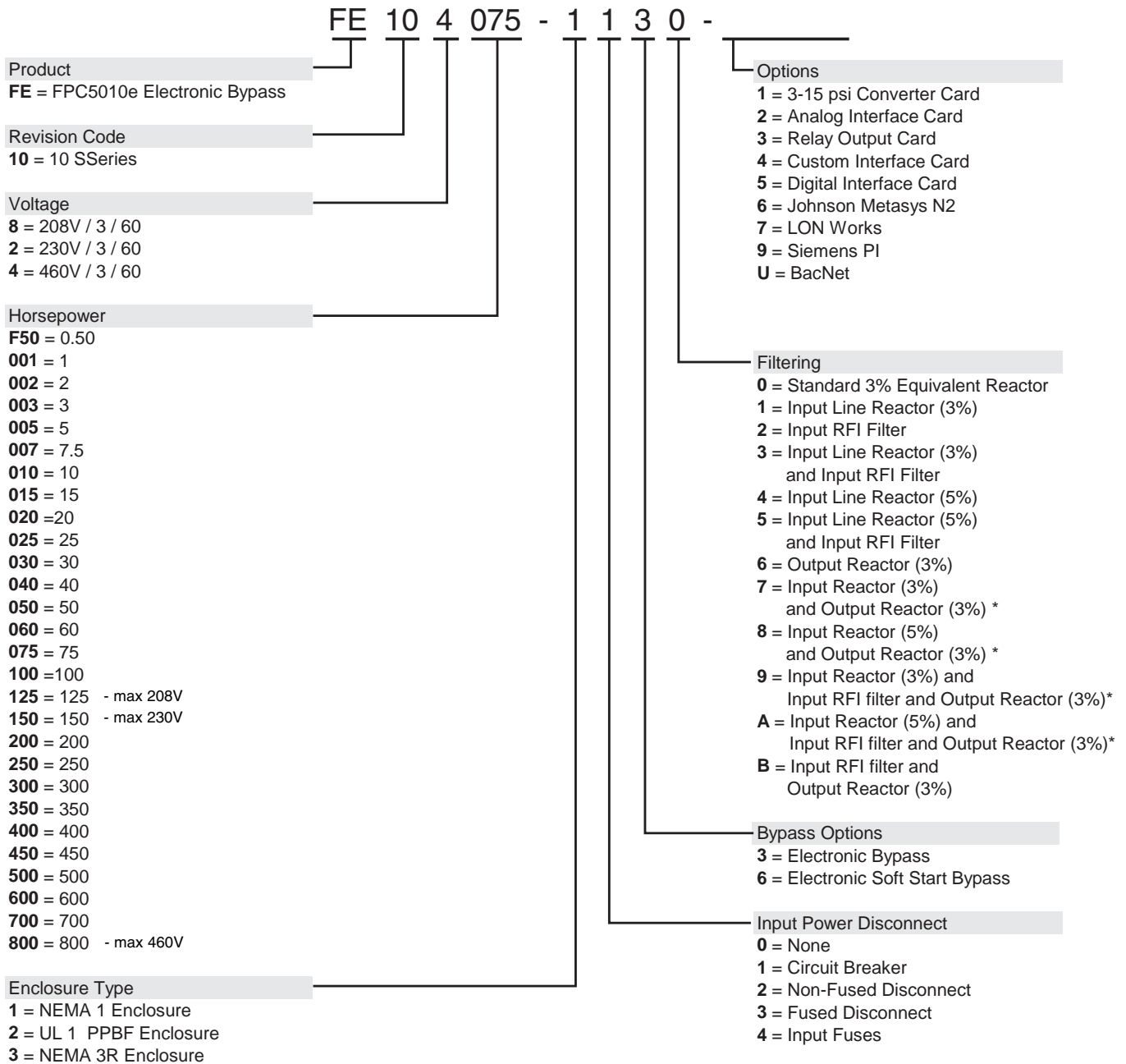

**PART NUMBER IDENTIFICATION: FPC10**

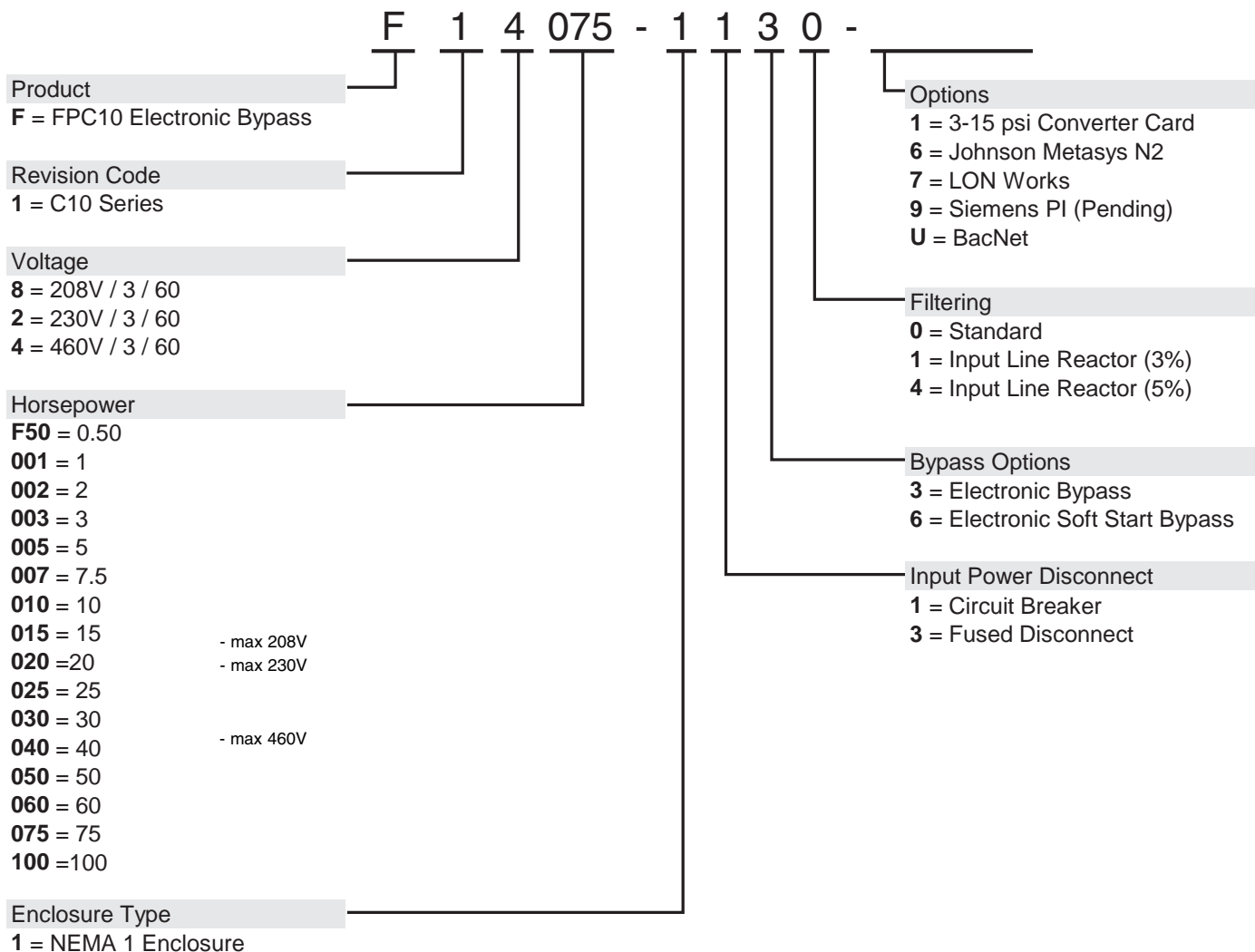

## 2.4 MOUNTING CLEARANCE

Install the Electronic bypass unit on a vertical surface and allow the following minimum clearances for normal heat dissipation.

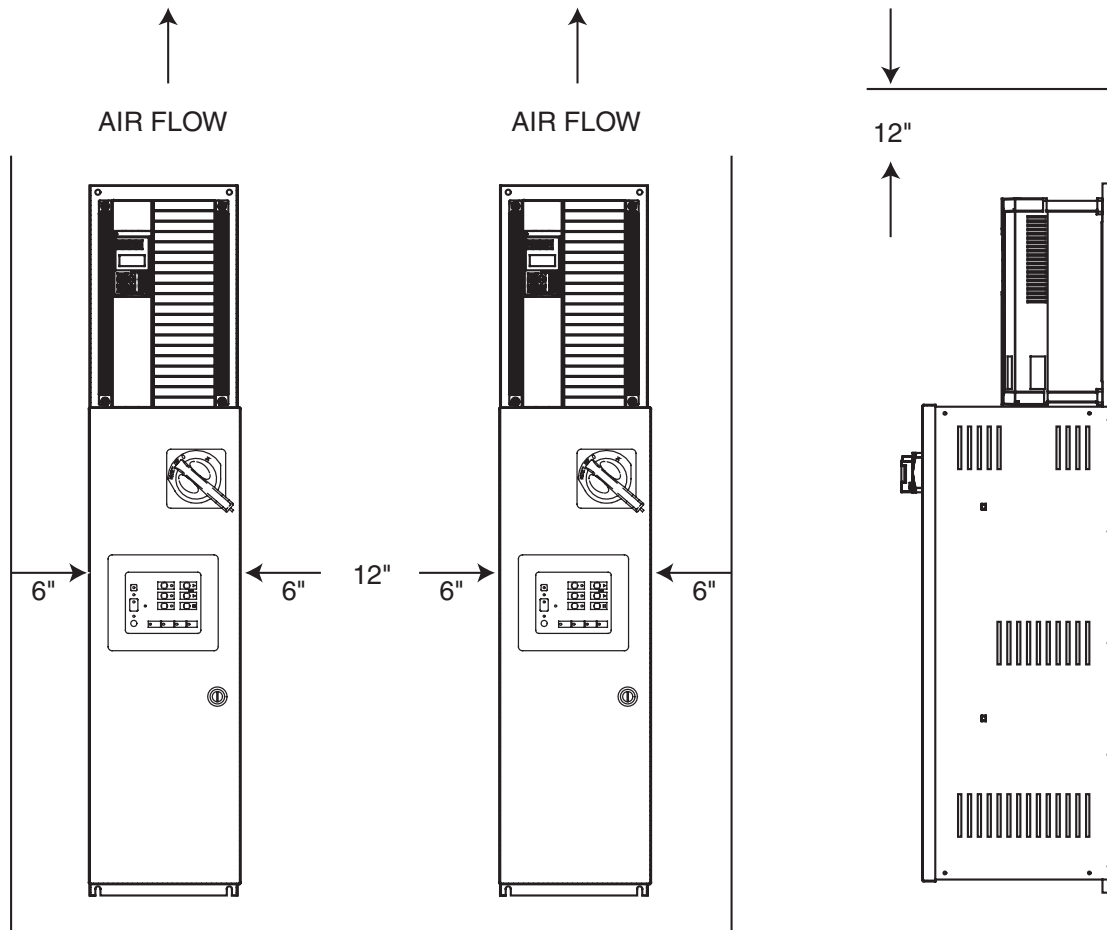

### Notes:

- FPC5010e: Ambient operating temperature; 14°F to 122°F ( -10°C to 50°C)
- FPC10: Ambient operating temperature; 14°F to 104°F ( -10°C to 40°C)
- Install the unit in a location free from oil mist and dust.
- Install the unit in a location free from radioactive materials, combustible materials, harmful gasses or liquids.
- Do not install the unit in a location susceptible to excessive vibrations
- Do not install the controller in direct sunlight
- During installation, protect the unit from foreign particles such as metal shavings produced by drilling.
- Failure to follow these notes could void the warranty.

---

## **2.5 WIRING AND PRECAUTIONS**

### **2.5.1 General**

1. **DO NOT** connect or disconnect wiring, or perform signal checks while the power supply is turned ON.
2. Connect the power supply wiring to terminals L1, L2 and L3 on the means of disconnect (if provided). **DO NOT** connect power supply wiring to output terminals T1, T2 and T3.
3. Connect the motor wiring to the Class 20 Motor O/L or the output reactor if installed. **DO NOT** connect power supply wiring to the VFD output terminals T1, T2 and T3.
4. Never touch the output circuit directly or place the output line in contact with the package enclosure.
5. **DO NOT** connect a phase advancing capacitor to the output circuit.
6. Power supply wiring and motor wiring must be in separate conduits with separate ground conductors. (Conduits shall **NOT** be used as ground)
7. Control wiring must be in conduit separate from both power supply and motor wiring.
8. Tighten the screws on the main circuit disconnect (if provided) and control circuit terminals.
9. Please observe National and Local codes when wiring electrical devices.

**Failure to observe these precautions may result in equipment damage or improper operation and may not be covered under warranty.**

### **2.5.2 Input Wiring**

The Electronic bypass unit may be supplied with several different input device options. These input options include protective devices as well as non-protective devices, it is the responsibility of the installing parties to ensure that branch circuit protection of the appropriate size and location is observed. The following input options are available. All incoming power is connected to terminals L1, L2, & L3.

- No input device (FPC5010e Only)
- Input fusing (FPC5010e Only)
- Non- Fused Disconnect (FPC5010e Only)
- Fused Disconnect
- Circuit Breaker

Connect the main power supply per the following diagrams. The phase sequence to the unit is irrelevant to output phase sequence of the Inverter. It will affect Bypass rotation.

### Input Power Connection Drawings

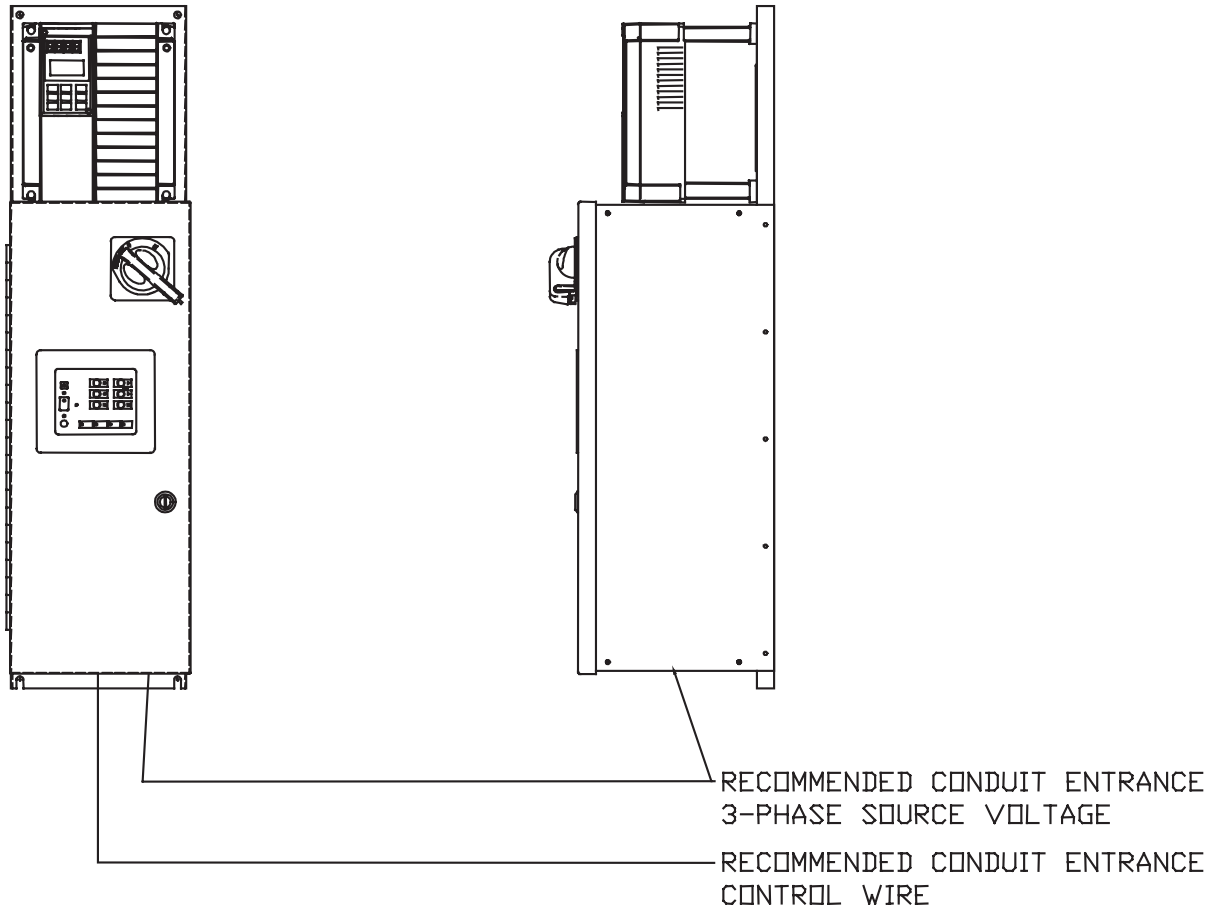

### 2.5.3 Output Wiring

The Electronic bypass unit is always supplied with a Class 20 Motor O/L on the output of the unit. However, the unit may be supplied with several different output options. The following output options are available.

- Single Motor O/L (Terminals T1, T2, & T3)
- Dual Motor O/L (Terminals (T1, T2, & T3 Motor 1) (T4, T5, & T6 Motor 2))

Connect the Motor leads to the unit per the following diagram.

Output Wiring Drawing

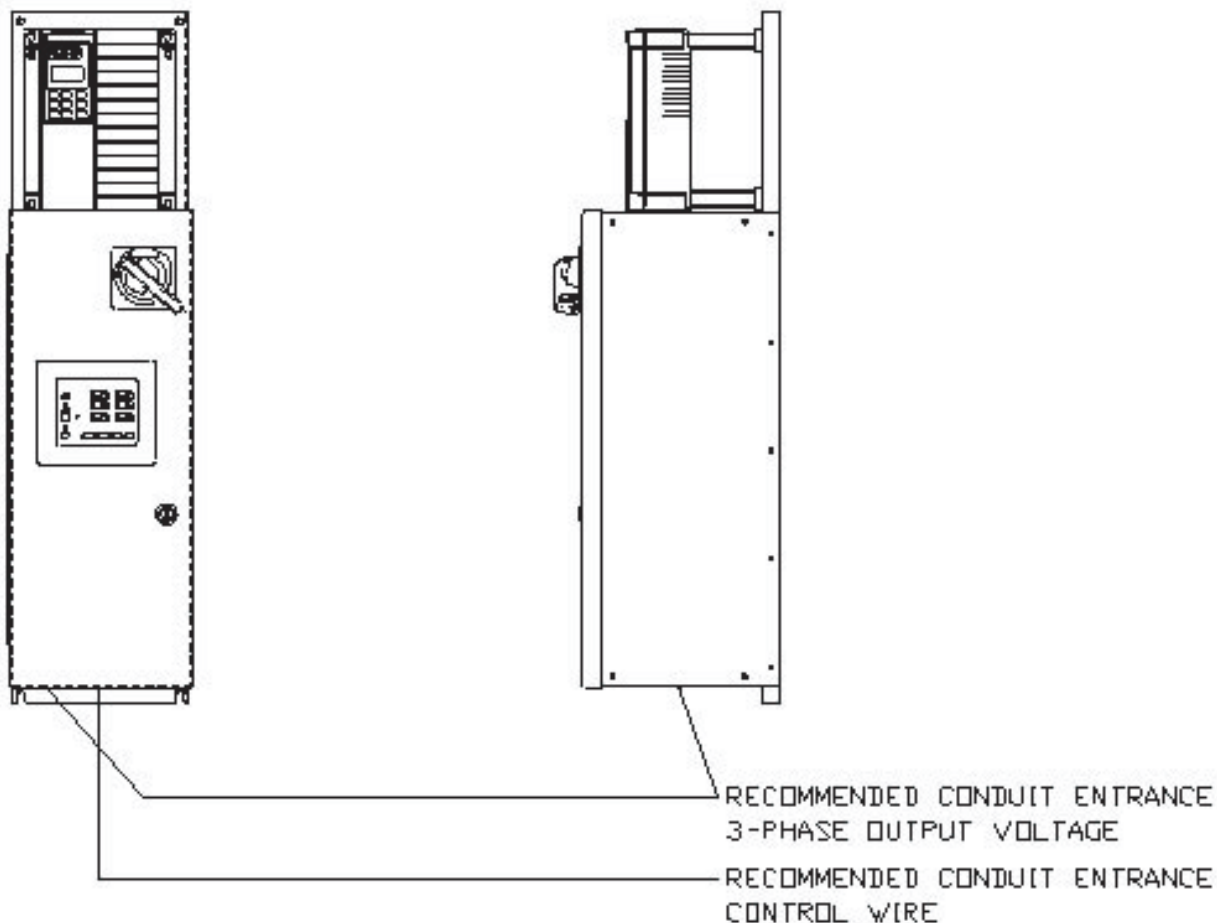

**Note:**

All contactors and relays supplied in the Electronic bypass package are suppressed. If adding additional inductive loads (i.e. magnetic contactors, magnetic relays, magnetic valves, solenoids, magnetic brakes, etc.) in or near the Electronic bypass package use a surge suppressor across the coils to limit the transients on the supply lines

## 2.5.4 Control Circuit Wiring (FPC5010e)

### 2.5.4.1 Analog Output

0-10Vdc analog output signal is available by connecting to GP10 terminals FMA (+) and 11 (-). Refer to GP10 manual 027-GP1001, parameter F31 for programming capabilities. The default is output frequency.

### 2.5.4.2 Digital Input

The Electronic bypass combines digital inputs from the GP10 inverter and the Electronic bypass control board to allow maximum flexibility. As per the following table, the Electronic bypass control board provides seven (7) digital inputs.

Terminal No.	Description
26	Safety (NC)
27	Reset
28	Automatic Run
29	Fire (NC)
32	Remote Bypass
33	Remote VFD
34	Damper Feedback
31 x 3	Common

As per the following table, the GP10 has the following six (6) terminals available for customer connection.

Terminal No.	Description
X1	Programmable
X2	Programmable
X3	Programmable
X4	Programmable
X5	Programmable
X6	Programmable
CM	Common

**All digital inputs are dry contact (voltage free).**

### 2.5.4.3 Digital / Relay Outputs

There are four (4) Form A relay outputs rated 125 Vac, 0.5amp. on the Electronic bypass control board.

Terminal No.	Description
41 and 42	Automatic mode selected
39 and 40	Damper actuator
37 and 38	Fault
35 and 36	Power On

Additionally the following relay output is available for customer connection from the GP10 Terminal Y5A and Y5C as a VFD Run output. Also available are four (4) open collector outputs.

#### 2.5.4.4 Internal Control Wire Connections

There are factory connections between the electronic bypass control board and the GP10 inverter. These connections as per the table below are made at the factory and are for reference only. Do Not change this wiring as it will cause the Electronic bypass to operate improperly or not at all.

Electronic bypass control Bd.	GP10	Wire number
J11 – 1	Overload relay contact	12
J11 – 2	30C	11
J11 – 3	CM	10
J11 – 4	X9	9
J11 – 5	X8	8
J11 – 6	FWD	6
J11 – 7	X7	7
J10 - 1	Input Contactor	1
J10 – 2	Bypass Contactor	3
J10 - 3	Output Contactor	2
J10 - 4	115 VAC (Neutral)	4
J10 - 5	115 VAC (Hot)	5

#### 2.5.4.5 Distance between FPC5010e and Motor

If the total wiring distance between the FPC5010e and the motor is excessively long and the VFD carrier frequency (IGBT switch frequency) is high, harmonic leakage current from the wiring may adversely affect the VFD and peripheral devices. If the wiring distance is long, reduce the inverter carrier frequency by using function code F26 "Motor sound".

7.5 Hp and Larger			
Motor Insulation Level	1000 Volts	1300 Volts	1600 Volts
230 Vac	1312 ft / 400M*	1312 ft / 400M*	1312 ft / 400M*
460 Vac	66 ft / 20 M	328 Ft / 100M*	1312 Ft / 400M*
5.0 Hp and Smaller			
Motor Insulation Level	1000 Volts	1300 Volts	1600 Volts
230 Vac	328 ft / 400M*	328 ft / 400M*	328 ft / 400M*
460 Vac	66 ft / 20 M	165 Ft / 100 M*	165 Ft / 400 M*

\*Cable lengths determined by secondary effects and not voltage spiking (dv/dt).

## **2.5.5 Control Circuit Wiring (FPC10)**

### **2.5.5.1 Analog Output**

0-10Vdc analog output signal is available by connecting to C10 terminals AO1 or AO2 (+) and GND (-). Refer to C10 manual 027-2163, parameter Bn-12 and Bn-13 for programming capabilities. The default for Bn-12 is frequency command, Bn-13 is output frequency.

### **2.5.5.2 Digital Input**

The Electronic bypass combines digital inputs from the C10 inverter and the Electronic bypass control board to allow maximum flexibility. As per the following table, the Electronic bypass control board provides seven (7) digital inputs.

Terminal No.	Description
26	Safety (NC)
27	Reset
28	Automatic Run
29	Fire (NC)
32	Remote Bypass
33	Remote VFD
34	Damper Feedback
31 x 3	Common

As per the following table, the C10 has the following two (2) terminals available for customer connection.

Terminal No.	Description
5	Programmable
8	Programmable
24VG	Common

**All digital inputs are dry contact (voltage free).**

### **2.5.5.3 Digital / Relay Outputs**

There are four (4) Form A relay outputs rated 125 Vac, 0.5amp. on the Electronic bypass control board.

Terminal No.	Description
41 and 42	Automatic mode selected
39 and 40	Damper actuator
37 and 38	Fault
35 and 36	Power On

Additionally the following relay output is available for customer connection from the C10 Terminals R2C and R2A as a VFD Run output. Also available is one (1) open collector output.

### 2.5.5.4 Internal Control Wire Connections

There are factory connections between the electronic bypass control board and the C10 inverter. These connections as per the table below are made at the factory and are for reference only. Do Not change this wiring as it will cause the Electronic bypass to operate improperly or not at all.

Electronic bypass control Bd.	C10	Wire number
J11 – 1	Overload relay contact	12
J11 – 2	R1A	11
J11 – 3	24VG	10
J11 – 4	7	9
J11 – 5	6	7
J11 – 6	1	6
J11 – 7	4	8
J10 - 1	Input Contactor	1
J10 – 2	Bypass Contactor	3
J10 - 3	Output Contactor	2
J10 - 4	115 VAC (Neutral)	4
J10 - 5	115 VAC (Hot)	5

### 2.5.5.5 Distance between FPC10 and Motor

If the total wiring distance between the FPC10 and the motor is excessively long and the VFD carrier frequency (IGBT switch frequency) is high, harmonic leakage current from the wiring may adversely affect the VFD and peripheral devices. If the wiring distance is long, reduce the inverter carrier frequency by using function code Cn-34 "Carrier Frequency".

Cable Length	<100 Ft.	100-165 Ft.	168-328 Ft.	> 329 Ft.
Carrier Frequency	15kHz Max	10kHz Max	5kHz Max	2.5kHz Max
Cn-34	(Cn-34 = 6)	(Cn-34 = 4)	(Cn-34 = 2)*	(Cn-34 = 1)*

\*Cable lengths determined by secondary effects and not voltage spiking (dv / dt).

### 2.5.6 Grounding

Grounding Resistance: 230V Class: 100Ω or less, 460V class: 10Ω or less.

Never ground the Electronic bypass in common with welding machines, motors, or other high current electrical equipment. Run all ground wires in a separate conduit.

When using several Electronic bypass units side by side, ground the units as shown below.

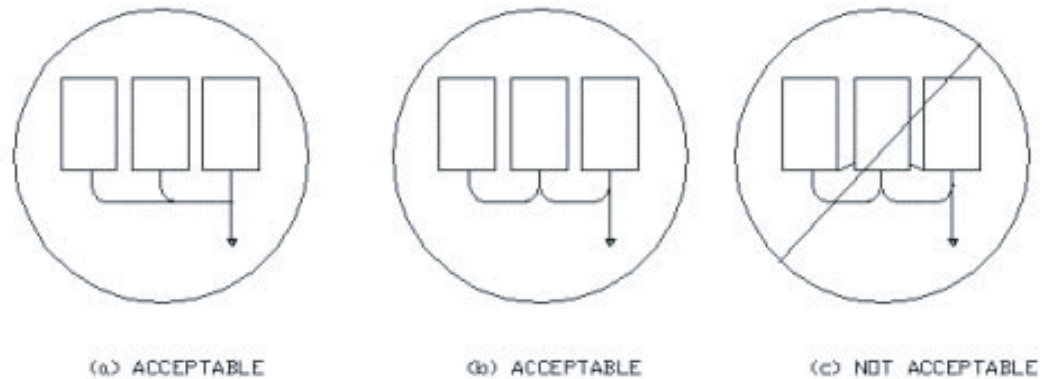

### 2.6 INSPECTION

After all wiring is completed, verify that:

- 1 - All wiring is installed.
- 2 - Excess screws and wiring clippings are removed from inside the unit(s).
- 3 - Screws and fasteners are securely tightened.
- 4 - Exposed wiring has no contact with other wiring or terminals.

### 2.7 CHECKING MOTOR ROTATION

Before attempting a trial operation of the Electronic bypass unit, insure that the enclosure door is securely closed. Also, insure all personnel are clear of the connected load as this operation will energize and rotate the motor. After applying 3 phase power to the Electronic bypass insure that the **MAIN POWER LED** is illuminated. If any alarms are illuminated refer to chapter 6 for explanation.

**WARNING:** Motor rotation **MUST** be checked in both VFD and Bypass modes. Failure to confirm rotation may cause severe damage to the Electronic bypass, motor or its driven equipment.

#### 2.7.1 Check #1: Rotation on VFD power

Place the VFD package in HAND (local) control by pressing the VFD and HAND push buttons of the ELECTRONIC BYPASS keypad. The VFD, HAND, and, input and output contactor LED's will be illuminated

Use the up arrow on the GP10 Keypad to increase the speed reference of the VFD or the down arrow on the GP10 Keypad to decrease the speed reference of the VFD. Note the direction of rotation as the motor shaft begins to rotate.

To stop the VFD, press the OFF/RESET push button.

Verify that the direction of the motor is correct, if not remove power to the unit and swap any two motor leads at the motor or at the motor overload device. **DO NOT** change the condition of the connections at T1, T2 and T3 on the drive. Perform this process again to verify the proper motor direction.

### **2.7.2 Check #2: Rotation on Bypass power**

**NOTE:** This operation will start the motor across-the-line.

Place the Electronic bypass in the BYPASS mode by pressing the BYPASS pushbutton on the Electronic bypass keypad. The BYPASS LED's will light.

Press the HAND button on the Electronic bypass keypad. This will start the motor across-the-line. Check motor rotation.

To stop the motor, press the OFF/RESET push button.

Verify that the direction of the motor is correct, if not remove power to the unit and swap any two leads on the bypass contactor. Perform this process again to verify the proper motor direction.

**NOTE:** It is extremely important that motor rotation be correct in both VFD and Bypass. Connected equipment or the VFD may be damaged.

## **CHAPTER 3 - OVERVIEW OF THE ELECTRONIC BYPASS**

All start/stop, safety, and Fire Alarm inputs are routed to the Electronic bypass control board via customer terminal connections. All speed reference inputs and outputs connected to the GP10 control terminals.

The Electronic bypass control card is factory set to accept a sinking type (dry contact closure) type input.

The analog inputs are factory set to accept either 0-10VDC or 4 -20mA speed reference signal.

All control wiring must be run in separate conduit from ANY high voltage or power wiring. The wiring should also be properly grounded and shielded when necessary to insure proper operation.

### **3.1 CONTROL BOARD**

The following is a description of the Electronic bypass control board configurable characteristics. DIP switch and jumper settings required to properly configure the Electronic bypass. All jumpers and switches are located on the control board, which is on the door.

- |    |                       |       |
|----|-----------------------|-------|
| 1. | Option Enable/Disable | (SW1) |
| 2. | Digital Inputs        | (J13) |
| 3. | Digital Outputs       | (J14) |
| 4. | Relay Outputs         | (J12) |

### **3.2 KEYPAD FUNCTION SUMMARY**

The keypad has (6) keys labeled TEST, VFD, BYPASS, HAND, AUTO, and OFF/RESET. Each key has an associated LED that indicates the state of that key's function. In addition, the keypad contains four alarm LEDs which indicate MOTOR OVERLOAD, EXTERNAL SAFETY, FIRE ALARM, and VFD FAULT. The left hand side of the keypad represents the bypass schematically using 5 LEDs to indicate POWER ON, INPUT CONTACTOR (closed), BYPASS CONTACTOR (closed), OUTPUT CONTACTOR (closed), BYPASS POWER ON, and VFD ENABLE. Finally, a RUN LED located between the HAND and AUTO keys gives an indication that the motor is running.

**Electronic Bypass Control Functions**

TYPE	LOCATION	TERMINAL	DESCRIPTION	SIGNAL LEVEL/RATING	
Input Power	J10	5	120V single phase	120Vac	
		4	120V single phase	Single Phase	
Contactor Outputs		1	Input Contactor		
		2	Bypass Contactor		
		3	Output Contactor		
VFD Connections		J11	1	Motor Overload Input	24 Vdc normal
			2	Drive Fault Input	24 Vdc normal
			3	24V Common to VFD	Drive common
	4		Freq. 1/2 HOA (X9)		
	5		Line Switching (X8)		
	6		Run Command (FWD)		
	7		VFD Reset (X7)		
Relay Outputs	TB1	1	Power On	Closes when	
		2	Power On	power is applied	
		3	Fault	Closes when	
		4	Fault	upon a fault condition	
		5	Damper	Activates Damper	
		6	Damper	Solenoid	
		7	Auto	Closes when	
		8	Auto	placed in Auto	
Digital Inputs	TB2	1	Safety Tie 1		
		2	Safety Tie 2		
		3	Safety	NC Contact	
		4	Customer Reset	NO Contact	
		5	Auto Run	NO Contact	
		6	Fire	NC Contact	
		7	Fused 24Vdc		
		8	24V Common	Digital Input Common	
Digital Inputs	TB3	1	Remote Bypass	Remote Bypass Command	
		2	Remote VFD	RemoteVFD Command	
		3	Damper Feedback	Feedback from end switch	
		4	N/A		
		5	N/A		
		6	N/A		
		7	N/A		
		8	N/A		
Digital Inputs	TB4	1	24V Common	Digital Input Common	
		2	24V Common	Digital Input Common	
		3	24V Common	Digital Input Common	
		4	N/A		
		5	Contactor Supply	115 Vac to Contactors	
		6	115 Vac Tie 1		
		7	115 Vac Tie 2		
		8	115 Vac Tie (Hot)	115Vac to Contactors	

**Electronic bypass Control Functions (cont.)**

**Speed Reference (Analog Inputs) GP10**

TYPE	LOCATION	TERMINAL	DESCRIPTION	SIGNAL LEVEL/RATING
Analog Inputs	GP10	12	External Speed Ref. Or PID Set Point Ref.	0-10VDC
		C1	External Speed Ref. Or PID Set Point Ref.	4-20mA
		11	Signal Common	***see page 2-6 & 2-7

**Speed Reference (Analog Inputs) C10**

TYPE	LOCATION	TERMINAL	DESCRIPTION	SIGNAL LEVEL/RATING
Analog Inputs	C10	VIN	External Speed Ref. Or PID Set Point Ref.	0-10VDC
		AIN	External Speed Ref. Or PID Set Point Ref.	4-20mA
		GND	Signal Common	***see page 2-6 & 2-7

**3.3 USING THE BYPASS CONFIGURATION SWITCHES ELECTRONIC BYPASS**

The bypass configuration switches are a group of four switches that are used to tailor the operation of the bypass for certain applications.

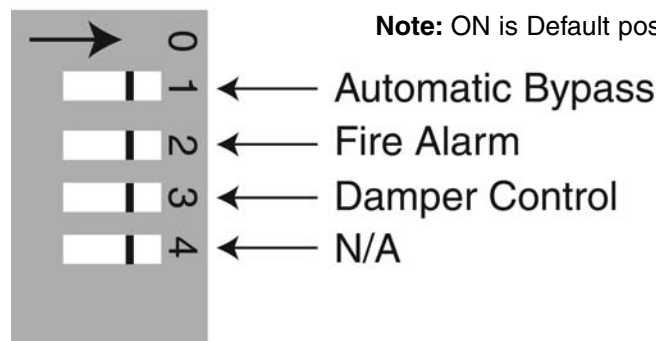

**Switch 1:** Enables or disables the automatic bypass function. With switch 1 disabled, and the bypass operating in VFD mode, a VFD fault will cause both the operation and run modes to be cancelled (stopping the motor) and the VFD fault indicator to illuminate in the alarms area on the keypad. With auto bypass enabled in the same situation, the drive fault will cause the bypass contactor to close, keeping the motor running on line power. As with the disabled configuration, the drive fault will be displayed in the alarms area on the keypad.

**Switch 2:** Controls the bypass response to a fire alarm condition. The default position of switch 2 causes the assertion of the fire alarm input to stop the motor independent of whether it was being run by the VFD or the line. When the motor is stopped in this situation, the previous operating state of the bypass can only be restored by removing the fire alarm signal, and cycling the customer reset input.

With switch 2 in the active position, the bypass will attempt to run the system "to destruction" in the event of fire. Receiving a fire alarm signal in this mode will force the mode to bypass, causing the motor to operate off the AC line. The motor cannot be stopped locally or by external contacts in this mode. The keypad will appear to be "locked out". Only cycling power to the bypass will return it to normal operation.

**Switch 3:** Used in damper applications where the VFD or bypass must make sure a damper has opened in order to continue to run the motor. The default position of switch 3 disables damper mode.

**NOTE:** With damper mode on however, once the motor has been started (either by VFD or by the AC line) a 120 second timer is started. The bypass must see the customer input "bypass feedback" asserted within that time to prevent the bypass from "faulting" by disabling the motor. The bypass will announce a faulted condition by flashing any of the key status LEDs that happened to be on at the time of the fault. The bypass can be reset by cycling the customer reset input, which will retry motor operation and reset the 120 second timer.

**NOTE:** Both Damper mode and Fire Alarm (Purge mode) may be activated at the same time. When both are activated and the Fire Alarm input is activated the unit will not switch into (Purge Mode) until the Damper feedback (End Switch) input is activated, at which time the unit will transfer into Bypass mode. Once in this mode of operation, a loss of the Damper feedback input will not disrupt the operation. To bring the unit out of Purge mode the Fire alarm input must close again indicating that the Fire alarm input is once again in its normal (non-fire) condition.

Should the damper open initially, but sometime during operation the feedback is lost, the bypass will trip, stopping the motor.

### **3.4 USING THE ADDITIONAL CUSTOMER INPUTS**

In addition to the inputs already described, there are three other customer inputs for use in specific applications.

**Safety** input: which is normally closed, causes the bypass to stop the motor under all conditions, and to lock out all requests to start the motor while the input is asserted. An indicator in the alarms section of the keypad announces the status of the safety input.

**NOTE:** If there are no safeties then a jumper must be installed to allow operation.

**Remote bypass** input: can be used to over-ride the key pad selections and force the bypass into bypass mode from an external contact. Once this signal is removed, the bypass will not return to its' previous mode of operation without keypad interaction.

**Remote VFD** input: works just like the remote bypass input, by forcing the bypass into VFD mode. The bypass will not return to its' previous mode when the signal is removed.

### **3.5 ALARM DISPLAYS**

The meaning of the alarms, indicating safety, fire alarm, and VFD fault have been discussed previously. The fourth alarm is motor overload, which is generated internally by the overload relay built into the bypass. Should this relay open, the bypass will stop the motor independent of its' mode of operation. The motor can not be restarted as long as the motor overload indicator is illuminated. Once the relay is reset, operation can be restored by reselecting a run mode from the keypad.

### **3.6 FAILURE AND POWER OFF CONDITIONS**

Should the bypass controller card fail such that it can not process inputs, the bypass has a fail safe mechanism for controlling the bypass contactors. Jumpers J5, J6, and J7 control the input, bypass, and output contactors respectively. Moving any of these jumpers from the default "open" position to the "emergency" position will force the associated contactor to become energized. This will happen irrespective to any potential logic damage on the bypass board.

In the event the bypass control board should lose power, an EEPROM memory retains the last operating configuration, which is restored on the next power up.

### **3.7 CONTROL MODES OF THE ELECTRONIC BYPASS**

When power is initially applied, the green MAIN POWER ON LED becomes illuminated and will remain on as long as power is connected. The OFF/RESET will be the only other LED illuminated. The input contactor remains in the off position. The VFD will have no power and its display will remain blank. An operation mode must first be selected, followed by the start mode selection.

#### **3.7.1 TEST mode**

In TEST mode the functionality of the VFD, external speed reference devices, SAFLINK communication tool and system set-up characteristics can be read, set and modified. In TEST mode the input contactor is energized.

To place the VFD package in TEST mode, press the TEST button. The TEST and input contactor LED's will be illuminated.

To exit the TEST mode, press the OFF/RESET button on the ELECTRONIC BYPASS keypad. The TEST and Input contactor LED's will go out.

#### **3.7.2 VFD mode**

In VFD mode both the input and output contactors are energized. A start mode pushbutton must be pressed before any further action can be realized.

To place the VFD package in VFD mode, press the VFD pushbutton. The VFD, input and output contactor LED's will be illuminated.

To exit the VFD mode, press the OFF/RESET button on the Electronic bypass keypad. The VFD, input and output contactor LED's will go out.

#### **3.7.3 BYPASS mode**

In BYPASS mode the bypass contactor is energized. A start mode pushbutton must be pressed before any further action can be realized.

To place the VFD package in BYPASS mode, press the BYPASS pushbutton. The BYPASS LED will be illuminated.

To exit the BYPASS mode, press the OFF/RESET button on the Electronic bypass keypad. The BYPASS LED will go out.

#### **3.7.4 HAND mode**

In the HAND mode, starting and stopping is controlled entirely from the door mounted pushbuttons. HAND mode controls both VFD and BYPASS operation modes

To place in HAND mode, press the VFD button. Then press the HAND button. The VFD, HAND, input and output contactors, and RUN LED's will be illuminated.

Pressing the HAND button acts as a run command for the VFD. Speed of the motor is controlled by the up /down arrow keys on the GP10 keypad.

To place in BYPASS mode, press the BYPASS button. Then press the HAND button. The BYPASS, HAND, bypass contactor, and RUN LED's will be illuminated.

To exit the HAND mode, press the OFF/RESET button once on the Electronic bypass keypad. The HAND, bypass contactor LED's will turn off. Press the OFF/RESET button again and it will turn off either the VFD or BYPASS LED's.

### **3.7.5 AUTO mode**

In the AUTO (automatic mode), a building automation system or other external device is required to supply start / stop and speed reference information to the Electronic bypass. During AUTO mode operation, the Electronic bypass keypad remains enabled for stopping, operation mode changing and bypass selection functions. AUTO mode controls both VFD and BYPASS operation modes

To place in AUTO mode, press the VFD button. Then press the AUTO button. The VFD, AUTO and input and output contactors LED's will be illuminated.

The RUN LED will not illuminate until the user supplied run contact closes. Speed of the motor is controlled by the user supplied reference signal (0-10Vdc or 4-20mA).

To place in AUTO mode, press the BYPASS button. Then press the AUTO button. The BYPASS and AUTO LED's will be illuminated. The bypass contactor and RUN LED's Will not illuminate until the user supplied run contact closes

To exit the AUTO mode, press the OFF/RESET button once on the ELECTRONIC BYPASS keypad. The HAND, bypass contactor LED's will turn off. Press the OFF/RESET button again and it will turn off either the VFD or BYPASS LED's.

## **3.8 BYPASS MODES OF THE ELECTRONIC BYPASS**

There are three modes of operation for bypassing the VFD and operating on full line power.

<b><i>Bypass</i></b>	Manual bypass operation
<b><i>Bypass Automatic</i></b>	Automatic bypass on VFD fault
<b><i>Emergency bypass</i></b>	Emergency, manual bypass

### **3.8.1 MANUAL Bypass**

In the manual bypass mode, the motor begins bypass operation immediately upon selecting HAND mode or upon user supplied contact closure in AUTO mode. The motor will stay in bypass until the user chooses to leave either HAND or AUTO mode. Bypass is also available in the TEST mode of operation. To place in BYPASS / manual bypass mode, press the BYPASS button to enter the BYPASS mode.

When the BYPASS LED illuminates, press either the HAND or AUTO button. When the HAND button is pressed the bypass contactor will energize and the motor will immediately be started across-the-line. When the AUTO button is pressed, the bypass contactor will not energize until the customer supplied run contact is closed, then the bypass contactor will energize and the motor will immediately be started across-the-line

To exit the BYPASS mode, Press OFF/RESET button on the Electronic bypass keypad.

### **3.8.2 AUTOMATIC Bypass on VFD Fault**

In the AUTOMATIC bypass on VFD fault mode of operation, when the Electronic bypass control board senses a VFD fault it will automatically switch the motor to BYPASS operation. This function is enabled by DIP switch 1, position 1, placed in the **OFF** position.

AUTOMATIC bypass can be selected in both the VFD AUTO and the VFD HAND modes of operation. The functionality in each mode is exactly the same.

**CAUTION:** Use caution when selecting this mode as the motor may accelerate to full speed anytime the VFD experiences any type of fault condition.

### **3.8.3 A) EMERGENCY Bypass**

In the unlikely event of a failure of the Electronic bypass control board, an emergency bypass jumper may be repositioned to enable the Electronic bypass to be operated as a full voltage fixed speed starter. The emergency bypass jumper is located on the component side of the door mounted control board. To change this jumper, use the door interlocked disconnects to open the enclosure door remove power from the Electronic bypass. Remove the 4 mounting screws from the control board. Turn the board so that the component side is facing you. Move jumper J6 from the open position (normal) to the emergency position. When the enclosure door is closed and the door interlock in the ON position, the coils to the bypass contactor will be immediately energized causing the contactor to close starting the motor at full across-the-line voltage.

To exit emergency bypass, turn the door interlocked disconnect to the OFF position. Power to the contactor coils will be removed and the bypass contactor will open disconnecting the operation of the motor. Remove the control board from the door and move jumper J6 from the emergency position to the open position. Close the enclosure door and place the door interlock in the ON position. Control will be returned to the control board for VFD or bypass operation.

### **3.8.3 B) EMERGENCY VFD**

Should the Electronic Bypass control board fail, and the VFD is still operational, jumpers J5 and J7 can be moved from the open position (normal) to the Emergency position. This will energize both the input and output contactors allowing line voltage to be applied to the VFD and the output voltage to be applied to the motor.

Additionally, you may desire to move the auto run signal connected between terminals 31 and 28 to the VFD terminals required for run.

(GP10 VFD terminals FWD and CM)

(C10 VFD terminals 1 and 24 VG)



**When in Emergency bypass mode the thermal motor overload relay will not protect the motor from an overload condition. Damage to the motor may occur.**

## CHAPTER 4 - PROGRAMMING

### 4.1 VFD / GP10 REQUIRED PROGRAMMING

The following **GP10** parameters must be set to the values shown in order to ensure proper operation of the Electronic bypass packages. **Once set DO NOT change any of the values.**

Parameter	Function Name (LCD Operator Display)	Description	Setting
F-01	Frequency Setting 1 (FREQ CMD1)	Speed Reference (0-10Vdc or 4-20mA)	3
F-02	Operation Method (OPR METHOD)	S/ST sequence via Terminals	1
E-07	X7 Terminal Function (X7 FUNC)	Alarm Reset	8
E-08	X8 Terminal Function (X8 FUNC)	Switching from line to drive	16
E-09	X9 Terminal Function (X9 FUNC)	Frequency Setting 2	11
C-30	Frequency Setting 2 (FREQ CMD2)	Speed Reference (Keypad)	0

### 4.2 VFD / C10 REQUIRED PROGRAMMING

The following **C10** parameters must be set to the values shown in order to ensure proper operation of the Electronic bypass packages. These settings are pre-programmed from the factory, via software part number 046-6080. **DO NOT change any of these values unless directed to by Saftronics technical support.**

Parameter	Function Name (LCD Operator Display)	Description	Setting
Sn-04	Run Source Selection (Run Source)	Terminal Operation	1
Sn-05	Frequency Command Selection 1 (Ref. Cmd.)	Speed Reference (0-10Vdc or 4-20mA)	1
Sn-26	Multi-Function Input	Ext. BB NO Contact	8
Sn-27	Multi-Function Input	Local/Remote Control II	24
Sn-28	Multi-Function Input	Speed control w/out PG	26

### 4.3 VFD / GP10 RECOMMENDED PROGRAMMING

The following is a list of parameters that should be programmed at the time of Start-up. These values are recommendations only, actual settings should be determined by application, conditions, and the policies of the equipment owners.

Parameter	Function Name (LCD Operator Display)	Description	Setting
F-06	Maximum Voltage	Sets the maximum line voltage	208/230/460
F-07	Accel Time 1	Sets time from complete stop to full speed	15-30 Seconds
F-08	Decel Time 1	Sets time from full speed to complete stop	30-60 Seconds
F-11	Motor Full Load Amperes	Sets motor full load amperes per motor nameplate	As Needed (in Amperes)
F-14	Restart Mode	Operation at Momentary power failure	4
F-16	Low Limit	Sets minimum operating speed	As needed
F-26	Carrier Frequency	Sets Carrier Frequency	15kHz or maximum for VFD rating
P-02	Motor Horsepower	Sets Motor Horsepower per motor nameplate	As Needed (in HP)
P-03	Motor Full load Amperes	Sets Motor Full load amperes for auto tune	As Needed (in Amperes)
P-04	Auto-Tune	Tunes VFD to Motor (Static)	1
P-05	Auto-Tune Online	Continuously tunes VFD to motor (Real Time)	1
H-04	Auto-Reset Tries	Sets the number of retry attempts after fault	As Needed (0-10)
H-05	Auto Reset Interval	Sets time to wait between restarts	10 Seconds
H-08	Reverse Lockout	Prevents reverse motor rotation	1
H-09	Start Mode (Catch a spinning Motor)	Allows VFD to find a rotating motor and match speed w/o tripping	2
H-10	Energy Saving Mode	Disabled	0
H-13	Auto-Restart	Sets the retry delay after momentary power loss	10 Seconds

Refer to GP10 Manual 027-GP1001 for full parameter list and explanation.

#### 4.4. VFD / C10 RECOMMENDED PROGRAMMING

The following is a list of parameters that been pre-programmed at the Factory. These values are recommendations only, actual settings should be determined by application, conditions, and the policies of the equipment owners.

Parameter	Function Name (LCD Operator Display)	Description	Setting
Sn-08	Reverse Lockout	Prevents reverse motor rotation	1
Sn-17	Fault Retry Setting	Sets the operation of the Fault relay during retry attempts	0
Sn-61	Applied Torque Mode	Selects either Constant or Variable Torque Mode	1
Bn-01	Accel Time 1	Sets time from complete stop to full speed	30 Seconds
Bn-02	Decel Time 1	Sets time from full speed to complete stop	30-60 Seconds
Cn-17	DC Injection Braking time at Start	DC Injects the motor for the time specified at start to stop windmilling motor	10 Seconds
Cn-24	Auto-Reset Tries	Sets the number of retry attempts after fault	5
Cn-34	Carrier Frequency	Sets Carrier Frequency	3

Refer to C10 Manual 027-2163 for full parameter list and explanation.

---

---

## CHAPTER 5 - OPERATION

# WARNING

### ***Precautions:***

1. **Motor rotation MUST be checked in both VFD and Bypass modes. Failure to confirm rotation may cause severe damage to the Electronic bypass, motor or its driven equipment.**
2. Only turn ON the input power supply after closing the front door.  
Do not open the front door while the package is powered up.
3. Do not touch the heatsink, due to very high temperatures.
4. Since it is easy to change operation from low to high speed, verify the safe working range of the motor and machine before operation.
5. **DO NOT** check signals during operation.
6. VFD parameters have been factory set for operation in the ELECTRONIC BYPASS package.  
**DO NOT** change these settings, as the total package will not operate properly.

***Failure to observe these precautions may result in equipment damage, serious personal injury or death.***

## 5.1 KEYPAD OPERATION

The Electronic bypass package utilizes two keypads in its operation. The VFD Keypad controls the speed in the HAND mode using the up and down arrow keys. In AUTO mode the customer supplied speed reference is connected to the VFD control terminal strip. The HVAC keypad controls the start/stop of the VFD and bypass as well as reacting to customer supplied safeties, Fire Alarm input, Damper control, auto transfer to bypass on VFD fault and other features and functions detailed in the herein.

The following photo shows the respective keypad locations.

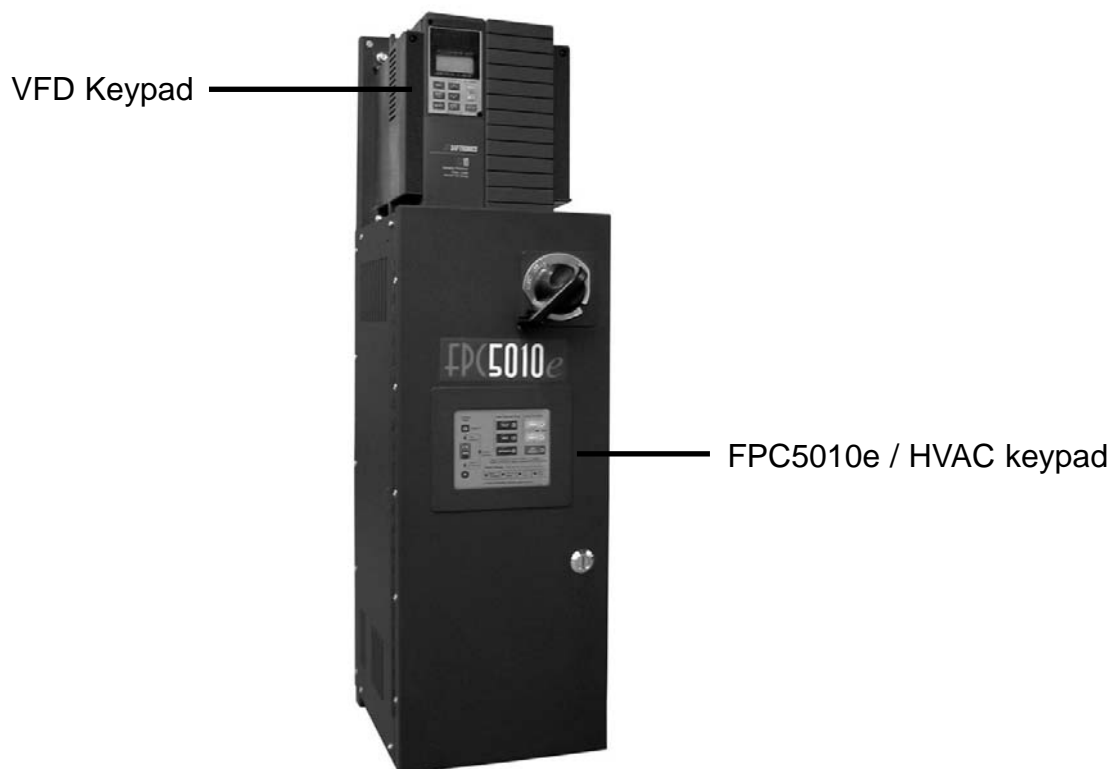

### 5.1.1 VFD Keypad

The keypad on the VFD is primarily used for speed control in hand mode and monitoring purposes as limited programming is required to operate the Electronic bypass. **See GP10 Manual 027-GP1001 or C10 Manual 027-2163 for detailed programming information.**

### 5.1.2 HVAC Keypad

Operation of the Electronic bypass VFD system is controlled by the Electronic bypass keypad located on the door of the lower enclosure.

### 5.1.3 Electronic Bypass Keypad Layout

There are four (4) main sections of the Electronic bypass keypad;

1. System status LED's
2. HOA - Hand / OFF / Auto buttons
3. Test - VFD - BYPASS control buttons
4. Alarm LED display

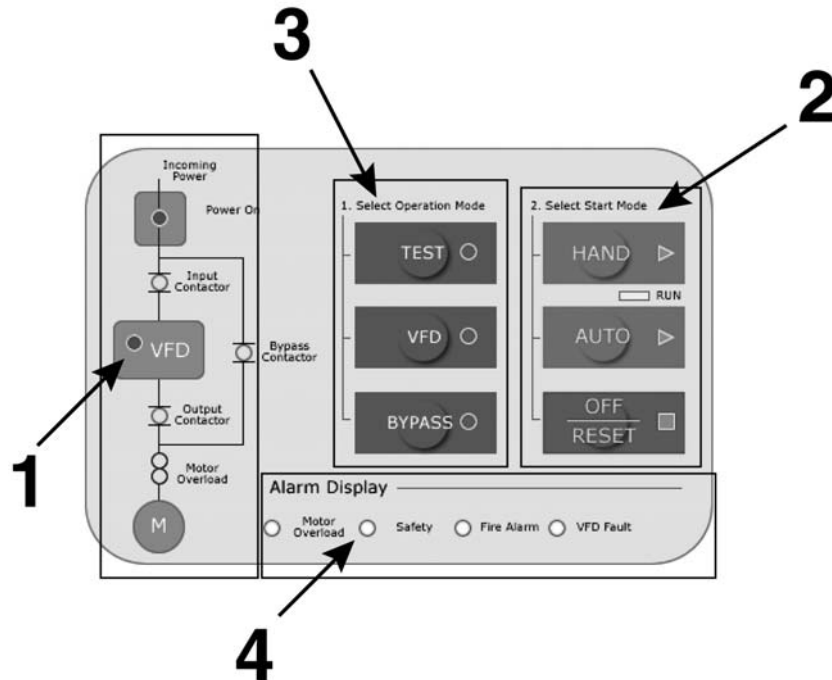

### 5.1.4 System Status LED's

The system status LED's represents a one line power diagram with a total of five (5) LED's located on the keypad:

1. Main power LED
2. VFD Power LED
3. Input contactor status LED
4. Output contactor status LED
5. Bypass contactor status LED

The operating status of the Electronic bypass can easily be seen. An illuminated LED indicates power ON, VFD running or contactor closed conditions.

---

### **5.1.5 Hand / OFF / Auto Buttons**

The HOA / TEST section offers simple control of the systems operation. There are three (3) modes of operation of the Electronic bypass;

1. HAND Mode (Local) Control via door mounted devices
2. AUTO Mode (Remote) Control via terminal connections.
3. OFF/RESET Mode Stops either HAND or AUTO operation

### **5.1.6 Test / VFD / Bypass buttons**

There are three (3) buttons and three modes of operation for selectable from the keypad.

1. TEST Mode Energizes input contactor
2. VFD Mode Energizes input and output contactors
3. BYPASS Mode Allows bypass operation

### **5.1.7 HVAC specific faults LED display**

There are four (4) LED's on the Electronic bypass keypad indicating the various application specific faults that may occur. They are as follows;

1. Motor Overload
2. Safety
3. Fire Alarm
4. VFD Fault

## 5.2 STARTING OPERATION

There are two (2) basic steps required to begin operation.

**Step 1** - Select operation mode by pressing as shown below. You must select one of these modes. For VFD operation press the VFD button. For Bypass operation press the BYPASS button. For Test operation press the TEST button. BYPASS and TEST buttons may be pressed together.

**Step 2** - Select start mode, by pressing either HAND or AUTO buttons. Selecting Hand allows an immediate start of VFD or BYPASS whichever was previously selected. The RUN LED will illuminate at this time. Selecting Auto will illuminate the AUTO LED. Run will not occur until the customer supplied run contact closes between terminals AUTORUN and 24V Common. The RUN LED will illuminate when that contact closes.

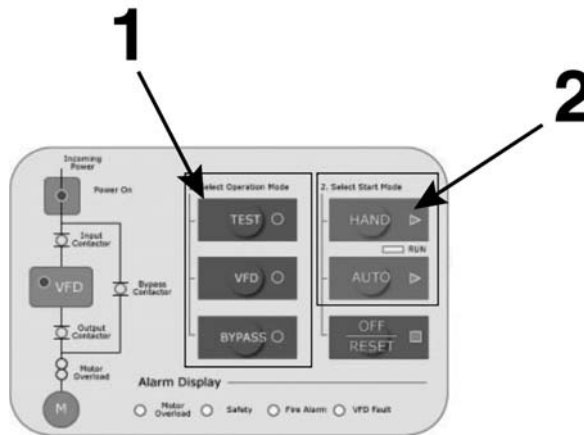

## 5.3 ENDING OPERATION

There are two (2) options available for ending operation.

- 1 - Press OFF/RESET button once- Cancels start mode of operation.
- 2 - Press 'OFF/RESET button twice - Cancels operation Mode.

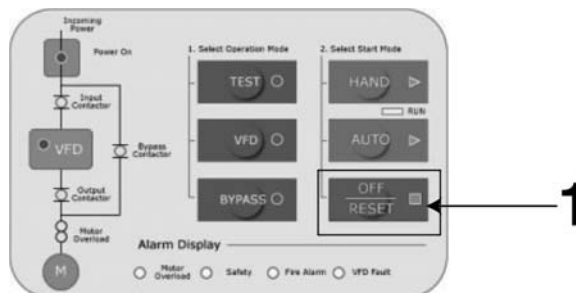

## CHAPTER 6 - ALARM & FAULTS

There are two different locations a fault or alarm will be displayed:

1. The HVAC Keypad
2. The VFD

### 6.1 HVAC KEYPAD ALARMS AND FAULTS

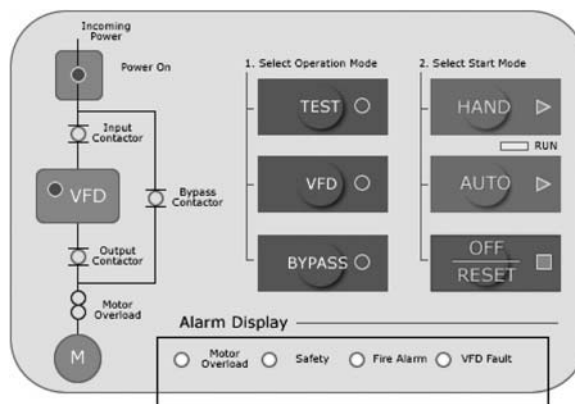

There are four (4) HVAC LED's on the Electronic bypass keypad indicating the various faults that may occur. They are as follows;

1. Motor Overload
2. Safety
3. Fire Alarm
4. VFD Fault

1. **Motor Overload:** Indicates that the manual motor overload relay has tripped.

Check that overload relay is properly set for motors full load ampere rating.  
Check for excessive motor current.

2. **Safety:** Indicates that an external safety interlock is in the open position.

**If a safety input is not used. Check terminal block for a jumper between 31 and 24.  
If a safety input is used. Verify that Safety contact is closed.**

3. **Fire Alarm:** Indicates that a Fire condition exists.

If fire alarm is set for purge mode VFD package will operate the motor at full speed. **Note: In purge mode all external safeties and motor overloads are disabled. The unit will "run to destruction" in this mode.**

If fire alarm is set for zero speed mode VFD package will disable the motor and prevent it from being operated in either VFD or bypass mode.

4. **VFD Fault:** Indicates that the VFD has had a fault.

The fault code will be specifically displayed on the VFD keypad. Section 7.2 that follows describes in detail the fault display, possible causes and remedies.

## **6.2 VFD ALARMS AND FAULTS**

See GP10 Manual 027-GP1001 or C10 Manual 027-2163 for detailed information.

## CHAPTER 7 - APPENDIX

### 7.1 SPECIFICATIONS

#### 7.1.1 Electronic Bypass

The Electronic bypass features Electronic Bypass. The Electronic bypass also features a user friendly application specific keypad to simplify operation and provide status indication.

**Approvals:** UL508c

**Design:**

- 3 contactor bypass
- NEMA 1 enclosure
- HVAC keypad / Annunciator Panel
  - 32-bit Microprocessor
  - Hand/Off/Auto Pushbuttons
  - Test/VFD/Bypass Pushbuttons
  - Auto transfer to bypass on fault (selectable)
  - Damper Mode (Programmable)
  - Damper actuator Control (.5 Amps @ 125Vac relay contact )
  - Smoke / fire alarm. Programmable to:
    - Purge mode
    - Zero speed mode
  - Four (4) relay outputs.
  - Dry contact digital inputs
- Narrow footprint
- PID controller
- Class 20 motor overload relays
- One (1) analog output:
  - 0-10 Vdc, scalable
- Two (2) analog inputs: Programmable for:
  - 0-10 Vdc, scalable
  - 4-20 mA, scalable
- Speed search function
- Digital manual speed control

**Operating conditions:**

- Altitude: to 3,300 ft, higher with derating
- Ambient operating temp. +14° to +122° F ( 10° to +50° C)
- Storage temp. 4° to +140° F ( 20° to +60° C).
- 95% Relative Humidity, non condensing.
- Input voltage +10%, -15%. 208, 230 and 460 Vac
- Protected to exposure to direct sunlight

**Options:**

Input non fused disconnect	Dual motor overloads
Input fused disconnect	EMI/RFI filters
Input circuit breaker	Metasys N2
Input fuses only	Lonworks
Input or output reactors	Siemens FLN (GP10 only)
	Ethernet
	Bacnet

### 7.1.2 GP10 Specifications

See GP10 Guide form Specification document 027-2129

### 7.1.3 C10 Specifications

See C10 Guide form Specification document 027-XXXX

## 7.2 LAYOUT AND DIMENSIONS

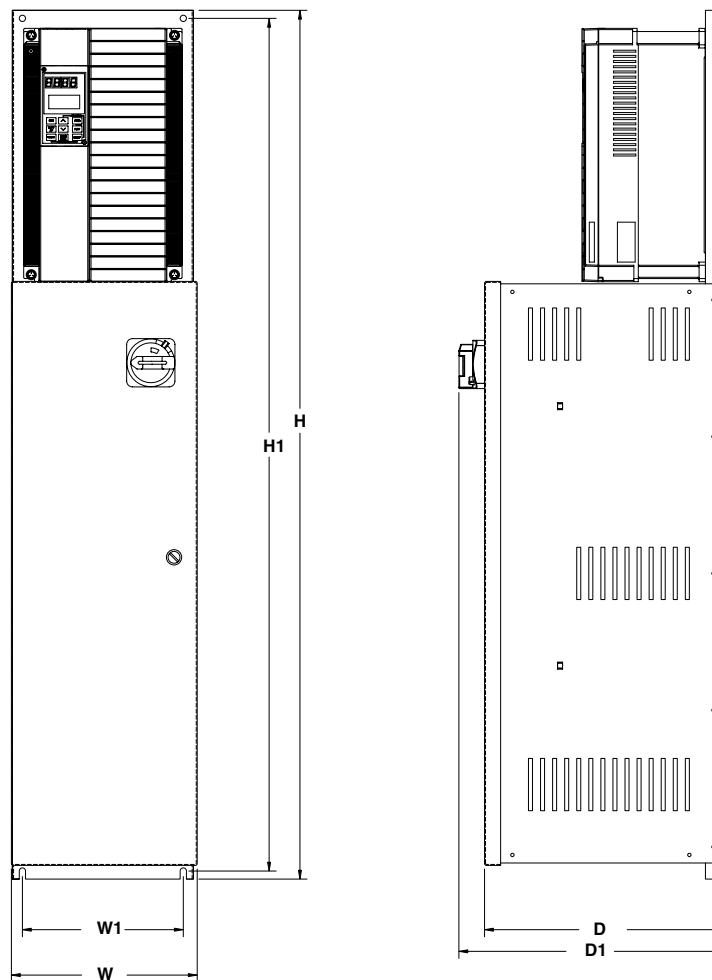

FPC510 & FPC5010e NEMA1

HORSEPOWER			DIMENSIONS (inches)						WEIGHT	
208 VAC	230 VAC	460 VAC	H = Height	W = Width	D = Depth	H1 = Height	W1 = Width	D1 = Depth	(lbs.)	
0.5-7.5 HP	0.5-10 HP	0.5-15 HP	40.5	10.3	13.15	38	9	12.82	56	
10-20 HP	15-25 HP	20-30 HP	54	11.25	13.95	53	10	16.36	85	
25-30 HP	30-40 HP	40-75 HP	70	16.75	14.10	71	16.75	13.82	216	
40-75 HP	50-75 HP	100-150 HP	Consult Factory							

### 7.3 MAINTENANCE & INSPECTION

This section describes the basic periodic maintenance and inspection procedures for the Electronic bypass.

**Caution ! To prevent electrical shock and damage, disconnect all power before servicing the Electronic bypass package. Then wait at least five minutes after the power supply is disconnected and all LED's are extinguished.**

The Electronic bypass will function longer if kept clean, cool and dry, and if all precautions highlighted in this manual are observed. Periodically inspect the Electronic bypass package as described in the table below to prevent accidents and to ensure high performance with high reliability.

Component	Check	Corrective Action
External terminals, Connectors, Mounting screws, etc.	Loose screws or connectors.	Secure tighten.
Heat sink	Build-up of dust and dirt.	Blow with dry compressed air (4 to 6kg-cm <sup>2</sup> pressure).
Printed Circuit Board (PCB)	Accumulation of conductive dust or oil.	Blow with dry compressed air (4 to 6kg-cm <sup>2</sup> pressure). If dust cannot be removed, replace the board.
Cooling Fan	For abnormal noise and vibration.	Replace the cooling fan.
Power components	Accumulation of dust and dirt.	Blow with dry compressed air (4 to 6kg-cm <sup>2</sup> pressure).

# WARNING

## 7.4 START-UP CHECKLIST

**Motor rotation MUST be checked in both VFD and Bypass modes. Failure to confirm rotation may cause severe damage to the Electronic bypass, motor or its driven equipment.**

### Pre-Power checks

Confirm proper operating voltage:	<input type="checkbox"/> 208V	<input type="checkbox"/> 230V	<input type="checkbox"/> 460V
Drive Mounted (per instruction manual)	<input type="checkbox"/> YES	<input type="checkbox"/> NO	
Input Wiring to drive: (in separate Conduit)	<input type="checkbox"/> YES	<input type="checkbox"/> NO	
Output Wiring to drive: (in separate Conduit)	<input type="checkbox"/> YES	<input type="checkbox"/> NO	
Ground wire from motor control to drive:	<input type="checkbox"/> YES	<input type="checkbox"/> NO	
Ground wire to motor from drive:	<input type="checkbox"/> YES	<input type="checkbox"/> NO	
Power ready to be energized to drive:	<input type="checkbox"/> YES	<input type="checkbox"/> NO	
Motor and load ready for operation:	<input type="checkbox"/> YES	<input type="checkbox"/> NO	

### Control Wiring

Automatic Start/Stop connected to 28 and 31:	<input type="checkbox"/> YES	<input type="checkbox"/> NO
Automatic Speed reference 0-10 VDC connected to 11 and 12 (GP10 only):	<input type="checkbox"/> YES	<input type="checkbox"/> NO
Automatic Speed reference 4-20 mA connected to 11 and C1 (GP10 only) :	<input type="checkbox"/> YES	<input type="checkbox"/> NO
Automatic Speed reference 0-10 VDC connected to VIN and GND (C10 only):	<input type="checkbox"/> YES	<input type="checkbox"/> NO
Automatic Speed reference 4-20 mA connected to AIN and GND (C10 only) :	<input type="checkbox"/> YES	<input type="checkbox"/> NO
Normally Closed Safety contact or Jumper connected to 26 and 31:	<input type="checkbox"/> YES	<input type="checkbox"/> NO
Normally Closed Fire contact or Jumper connected to 29 and 31:	<input type="checkbox"/> YES	<input type="checkbox"/> NO
Factory Jumper connected to 45 and 46:	<input type="checkbox"/> YES	<input type="checkbox"/> NO

### Power Up Checks

#### Close door disconnect if supplied

Power ON LED illuminated:	<input type="checkbox"/> YES	<input type="checkbox"/> NO
Motor rotation in VFD Mode:	<input type="checkbox"/> CW	<input type="checkbox"/> CCW
Motor rotation in Bypass Mode:	<input type="checkbox"/> CW	<input type="checkbox"/> CCW
Motor rotation same in VFD and Bypass	<input type="checkbox"/> YES	<input type="checkbox"/> NO
Automatic controls functional	<input type="checkbox"/> YES	<input type="checkbox"/> NO



## ADJUSTABLE FREQUENCY DRIVE STARTUP CHECKLIST

Startup Technician's Name: \_\_\_\_\_ Company Name: \_\_\_\_\_  
 Customer: \_\_\_\_\_ Installation Site: \_\_\_\_\_ Startup Date: \_\_\_\_\_  
 Sales Order #: \_\_\_\_\_ Service Order #: \_\_\_\_\_ Serial #: \_\_\_\_\_  
 Model #: \_\_\_\_\_ Application Description: \_\_\_\_\_

### Checklist

- |                          |                          |   |
|--------------------------|--------------------------|---|
| NO                       | YES                      | (Note any discrepancy in checklist findings in comment field)   |
| <input type="checkbox"/> | <input type="checkbox"/> | Unit ready for startup with all connections made and control interface, power and load available?             |
| <input type="checkbox"/> | <input type="checkbox"/> | Enclosure inspected for shipping damage, physical integrity; door, latch and lock operation?                  |
| <input type="checkbox"/> | <input type="checkbox"/> | Line and motor power connections tight and made to proper terminals with satisfactory clearances?             |
| <input type="checkbox"/> | <input type="checkbox"/> | Control wiring present and made to proper terminals and pull apart terminal blocks fully engaged?             |
| <input type="checkbox"/> | <input type="checkbox"/> | Physical installation and wiring conform to factory drawings or manuals as required?                          |
| <input type="checkbox"/> | <input type="checkbox"/> | Control devices, contactors, overloads, breakers, switches, operating mechanisms, interlocks OK?              |
| <input type="checkbox"/> | <input type="checkbox"/> | Separate AC line reactor, DC link reactor, or dynamic brake module/resistor, if supplied, properly installed? |
| <input type="checkbox"/> | <input type="checkbox"/> | Basic settings, application specific settings, and purchased options setup completed?                         |

### Line voltage and current

$V_{L12}$ : \_\_\_\_\_  $V_{L31}$ : \_\_\_\_\_  $I_{L2}$ : \_\_\_\_\_  
 $V_{L23}$ : \_\_\_\_\_  $I_{L1}$ : \_\_\_\_\_  $I_{L3}$ : \_\_\_\_\_

### Motor Nameplate

HP: \_\_\_\_\_ FLA: \_\_\_\_\_ PF: \_\_\_\_\_  
 RPM: \_\_\_\_\_ LR Code: \_\_\_\_\_ EFF: \_\_\_\_\_

### Parameters changed from factory default and new value

Parameter	Value	Parameter	Value	Parameter	Value
_____	_____	_____	_____	_____	_____
_____	_____	_____	_____	_____	_____
_____	_____	_____	_____	_____	_____
_____	_____	_____	_____	_____	_____
_____	_____	_____	_____	_____	_____
_____	_____	_____	_____	_____	_____
_____	_____	_____	_____	_____	_____
_____	_____	_____	_____	_____	_____
_____	_____	_____	_____	_____	_____

Comms Address: \_\_\_\_\_

### Comments

\_\_\_\_\_  
 \_\_\_\_\_  
 \_\_\_\_\_  
 \_\_\_\_\_  
 \_\_\_\_\_



Saftronics, Inc.  
5580 Enterprise Parkway  
Fort Myers, FL 33905  
Phone: (239) 693-7200  
Fax: (239) 693-2431  
© Copyright Saftronics, Inc. 2004

Manual Part Number 027-2174  
Rev. 08/2005