

Installing and Operating the VSM500™ Integrated Drive/Motor Version 3.0



INDUSTRIAL CONTROL EQUIPMENT 882R.

Instruction Manual D2-3400-3

Rockwell
Automation

The information in this manual is subject to change without notice.

Throughout this manual, the following notes are used to alert you to safety considerations:



ATTENTION: Identifies information about practices or circumstances that can lead to personal injury or death, property damage, or economic loss.

Important: Identifies information that is critical for successful application and understanding of the product.

The thick black bar shown on the outside margin of this page will be used throughout this instruction manual to signify new or revised text or figures.



ATTENTION: Only qualified personnel familiar with the construction and operation of this equipment and the hazards involved should install, adjust, operate, and/or service this equipment. Read and understand this instruction manual in its entirety before proceeding. Failure to observe this precaution could result in severe bodily injury or loss of life.

ATTENTION: After disconnecting input power, wait five minutes and check with a voltmeter to insure that DC bus capacitors are discharged. The voltmeter should read zero volts. Failure to observe this precaution could result in severe bodily injury or loss of life.

ATTENTION: High voltage and rotating parts can cause serious or fatal injury. Installation, operation, and maintenance of electrical machinery should be performed by qualified personnel. Make sure that the motor and equipment are grounded and protected in accordance with the National Electric and local codes. See NEMA MG-2 safety standard.

ATTENTION: The user is responsible for conforming with all applicable local, national, and international codes. Failure to observe this precaution could result in personal injury and/or damage to, or destruction of, the equipment.

DeviceNet™ is a trademark of the Open DeviceNet Vendor Association.

VSM500™ and Reliance™ are trademarks of Rockwell Automation.

©2000 Rockwell International Corporation

CONTENTS

Checklist	Installation Checklist	
Chapter 1	Step 1 - Identify Your Unit	
	1.1 VSM500 Standard Unit.....	1-2
	1.1.1 Standard Unit Display Description.....	1-2
	1.1.2 Standard Unit Reverse LED Description.....	1-2
	1.1.3 Standard Unit Communications LED Description.....	1-3
	1.2 VSM500 Local Operator Control Unit.....	1-3
	1.2.1 Local Operator Control Unit Key Descriptions.....	1-4
	1.2.2 Local Operating Control Unit Display Description.....	1-4
	1.2.3 Local Operating Control Unit Reverse LED Description.....	1-4
	1.2.4 Local Operator Control Unit Communications LED Description.....	1-4
	1.2.5 Operating the Unit Using the Local Operator Controls.....	1-5
	1.3 Option Kits.....	1-5
Chapter 2	Step 2 - Plan the Installation	
	2.1 Wire Routing Guidelines.....	2-3
	2.2 Handling and Lifting Guidelines.....	2-4
Chapter 3	Step 3 - Mount the Unit	
	3.1 Mounting Guidelines for Reliance Face-Mounted Motors.....	3-1
	3.2 Mounting Dimensions for NEMA Frames.....	3-2
Chapter 4	Step 4 - Install External Components	
	4.1 Installing an AC Input Disconnect.....	4-1
	4.2 Installing Branch Circuit Protection.....	4-1
	4.3 Installing Input Isolation Transformers.....	4-2
Chapter 5	Step 5 - Wire AC Power to the Unit and Ground the Unit	
	5.1 Grounding the Unit.....	5-3
Chapter 6	Step 6 - Install an Emergency Stop	
	6.1 Compliance with Machinery Safety Standard EN 60204-1: 1992.....	6-1
Chapter 7	Step 7 - Wire the Control Signal Terminal Block	
	7.1 Wiring Function Loss.....	7-4
	7.2 Wiring the Analog Output.....	7-5
	7.3 Wiring the Relay Control Output.....	7-6
	7.4 Wiring RPM or %Load Display.....	7-7
	7.5 Wiring the Speed Reference.....	7-7
	7.5.1 Wiring the Preset Speed Inputs.....	7-8
	7.5.2 Wiring the Speed Reference Signal Potentiometer.....	7-9
	7.5.3 Wiring an External Speed Reference (0 to 10 VDC or 4 to 20 mA)....	7-10
	7.6 Wiring Start / Stop Control.....	7-12
	7.7 Wiring Forward / Reverse Control.....	7-13
	7.8 Wiring Reset Control.....	7-14

Chapter 8	Step 8 - Verify the Setup and Adjust Switches if Required	
8.1	Adjusting the Maximum Speed	8-3
8.2	Adjusting the Acceleration / Deceleration Time	8-4
8.3	Modifying the Setup Using the Setup Slide Switch	8-5
8.3.1	Power-Up Start (Position 1)	8-6
8.3.2	Speed Reference Select (Position 2).....	8-6
8.3.3	Relay Control Output - Running or Faulted (Position 3)	8-7
8.3.4	Auto Restart (Position 4).....	8-7
8.3.5	Torque Curve (Position 5).....	8-8
8.3.6	Stop Type (Position 6)	8-9
8.3.7	Reverse Disable (Position 7)	8-9
8.3.8	Minimum Speed Select (Position 8).....	8-9
8.3.9	Start Mode Select (Position 9)	8-11
8.3.10	Parameter Mode for DeviceNet Option (Position 10)	8-11
Chapter 9	Step 9 - Check the Installation	
9.1	Checking the Installation with the Power Off.....	9-1
9.2	Checking the Direction of Motor Rotation	9-2
9.3	Attaching the Cover.....	9-2
9.3.1	Rotating the Cover	9-3
9.4	Checking the Speed Reference	9-4
Chapter 10	Step 10 - Set the Operating Speed	
Chapter 11	Diagnostics and Troubleshooting	
11.1	Fault Codes and Corrective Actions.....	11-2
11.2	Troubleshooting Tables.....	11-5
11.3	Replacement Parts.....	11-7
11.4	Replacement Part Compatibility.....	11-9
Chapter 12	Maintenance Guidelines	
12.1	General Unit Maintenance	12-1
12.2	Motor Maintenance	12-1
Appendix A	Technical Specifications.....	A-1
Appendix B	Product Features.....	B-1
Appendix C	VSM500 System Diagram.....	C-1
Appendix D	Installation Record	D-1
Appendix E	Replacing the Drive Section or the Motor Section	E-1
Appendix F	CE Conformity.....	F-1
Index	Index-1

List of Figures

Figure 1.1 – VSM500 Standard Unit.....	1-2
Figure 1.2 – VSM500 Local Operator Control Unit.....	1-3
Figure 1.3 – Local Operator Controls Key Functions.....	1-4
Figure 2.1 – Component Location	2-1
Figure 2.2 – Access Clearances.....	2-2
Figure 2.3 – Wire Routing Locations	2-3
Figure 3.1 – NEMA Frame Mounting Dimensions	3-2
Figure 5.1 – Removing the Cover.....	5-2
Figure 5.2 – AC Input Power Connections	5-2
Figure 7.1 – Control Signal Terminal Block	7-1
Figure 7.2 – Typical Control Signal Connections for Standard Units and Local Operator Control Units Set Up for Terminal Block Control	7-2
Figure 7.3 – Typical Control Signal Connections for Local Operator Control Units..	7-3
Figure 7.4 – Function Loss Control Wiring	7-4
Figure 7.5 – Analog Output Wiring	7-5
Figure 7.6 – Relay Control Output Wiring.....	7-6
Figure 7.7 – RPM or %Load Display Wiring	7-7
Figure 7.8 – Preset Speed Input Wiring.....	7-8
Figure 7.9 – Speed Reference Potentiometer Wiring.....	7-9
Figure 7.10 – 0 to 10 VDC External Speed Reference Wiring.....	7-10
Figure 7.11 – 4 to 20 mA External Speed Reference Wiring.....	7-11
Figure 7.12 – Start / Stop Control Wiring.....	7-12
Figure 7.13 – Forward / Reverse Control Wiring	7-13
Figure 7.14 – Reset Control Wiring	7-14
Figure 8.1 – Factory Settings for the Setup Rotary Switches and Slide Switch	8-2
Figure 8.2 – Maximum Speed Rotary Switch	8-3
Figure 8.3 – Acceleration / Deceleration Rotary Switch	8-4
Figure 8.4 – Setup Slide Switch Selections.....	8-5
Figure 8.5 – Torque Curves.....	8-8
Figure 8.6 – Wiring Minimum Speed	8-10
Figure 9.1 – Changing the Definition of Forward and Reverse.....	9-2
Figure 9.2 – Rotating the Cover.....	9-3

List of Tables

Table 1.1 – Model Number Format.....	1-1
Table 1.2 – VSM500 Option Kits	1-5
Table 4.1 – Required AC Branch Circuit Protection	4-1
Table 4.2 – Input Line Reactors.....	4-2
Table 7.1 – Fixed Preset Speed Selections.....	7-8
Table 8.1 – Auto Restartable Faults	8-8
Table 11.1 – Fault Codes and Corrective Actions	11-2
Table 11.2 – Display Not On.....	11-5
Table 11.3 – Motor Will Not Start.....	11-5
Table 11.4 – Motor Rotates but Does Not Accelerate to Full Speed.....	11-5
Table 11.5 – Motor Stops While Running.....	11-5
Table 11.6 – Motor Runs, But Not with Expected Performance	11-6
Table 11.7 – Replacement Parts for 460 VAC Units	11-7
Table 11.8 – Replacement Parts for 230 VAC Units	11-8
Table 11.9 – Replacement Parts for 115 VAC Units	11-8
Table 11.10 – Replacement Bearings	11-9
Table 11.11 – Replacement Part Compatibility	11-9

CHECKLIST

Installation Checklist

This manual describes how to install, troubleshoot, and maintain the VSM500 unit. Use the following checklist to guide you through the installation process.

Installation Procedure		Read Manual Section(s)
<input type="checkbox"/> Step 1	Identify your unit	1.0
	Understand how the standard unit operates	1.1
	Understand how the local operator control unit operates	1.2
<input type="checkbox"/> Step 2	Plan the installation If your installation must be in compliance with the European Community Electromagnetic Compatibility Standards, refer to Appendix F before proceeding.	2.0
<input type="checkbox"/> Step 3	Mount the unit	3.0
<input type="checkbox"/> Step 4	Install external components AC input disconnect Branch circuit protection Input isolation transformers	4.0 4.1 4.2 4.3
<input type="checkbox"/> Step 5	Wire AC power to the unit and ground the unit	5.0
<input type="checkbox"/> Step 6	Install an emergency stop	6.0
<input type="checkbox"/> Step 7	Wire the control signal terminal strip	7.0
<input type="checkbox"/> Step 8	Verify the setup and adjust it if required	8.0
<input type="checkbox"/> Step 9	Check the installation Perform power-off checks Verify the direction of motor rotation Attach the cover Check the speed reference	9.0 9.1 9.2 9.3 9.4
<input type="checkbox"/> Step 10	Set the operating speed	10.0

If problems occur during unit operation, refer to chapter 11 for troubleshooting guidelines.

Getting Assistance from Reliance Electric

If you have any questions or problems with the products described in this instruction manual, contact your local Reliance Electric sales office. For technical assistance, note the unit's model number and call 1-800-726-8112.

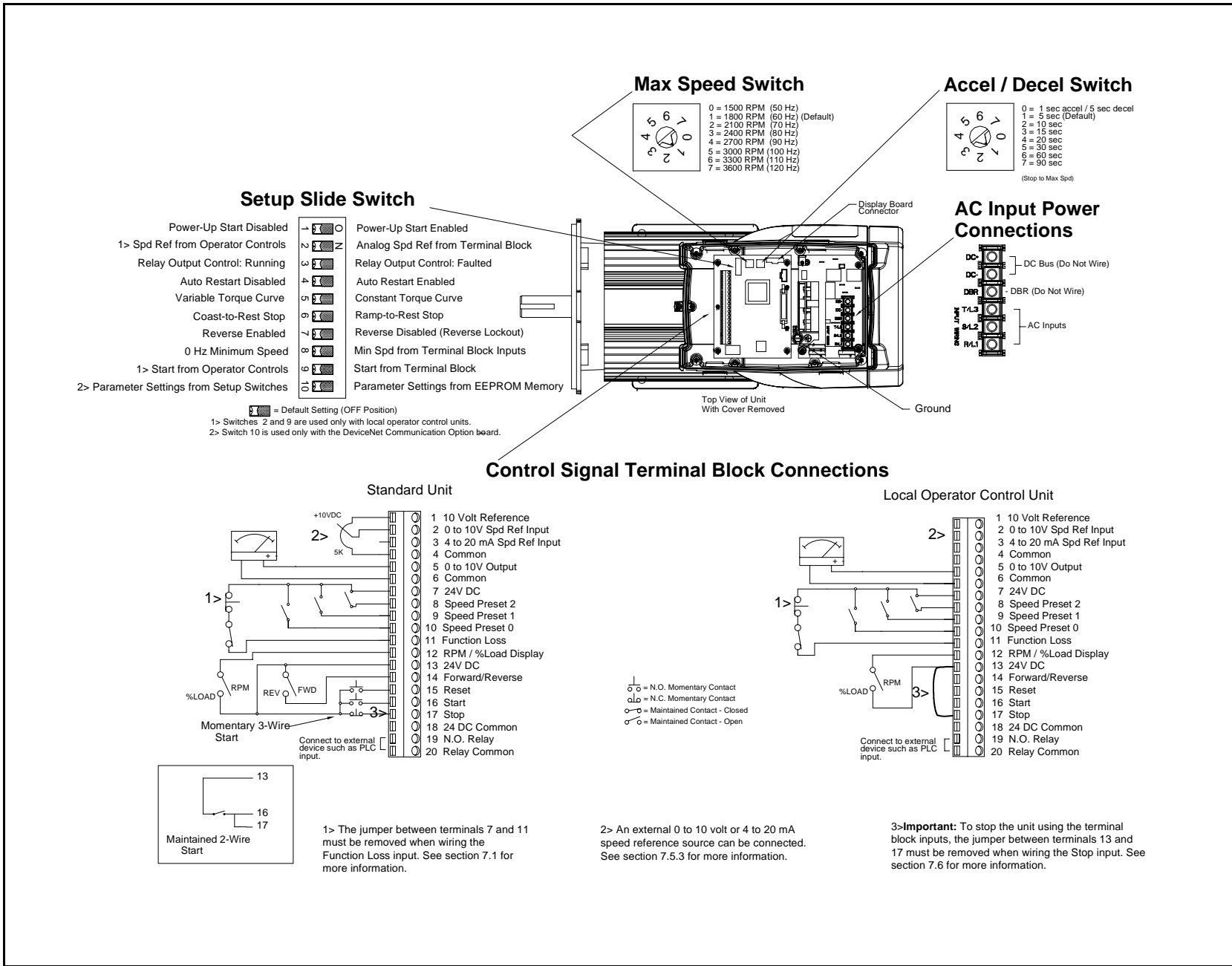

Step 1 - Identify Your Unit

The VSM500™ integrated drive/motor is an AC drive integrally mounted with an inverter duty motor. Each unit consists of a drive section and a motor section.

The drive section is a single- or three-phase input, three-phase output inverter providing open loop V/Hz regulation. It houses the PC boards and the blower. The motor section is a four-pole, three-phase induction motor.

The unit's default setup suits a wide range of applications. Two rotary switches and a 10-position slide switch on the Regulator board are used to adjust the setup, if required.

VSM500 units are identified by model number. This number appears on the shipping label and on the unit's nameplate. Table 1.1 shows the format of this number and what it indicates.

Table 1.1 – Model Number Format

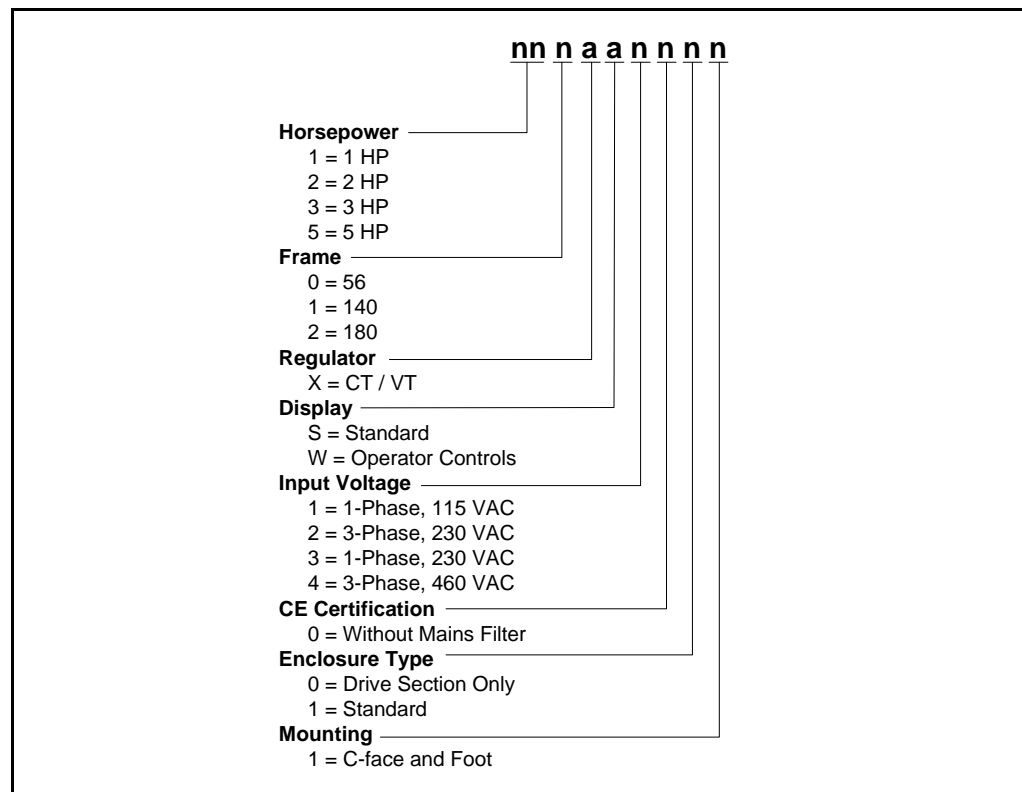

Standard units, described in section 1.1, provide remote operator control. Local operator control units, described in section 1.2, provide local (default) or remote (user option) control.

1.1 VSM500 Standard Unit

The standard unit, shown in figure 1.1, provides a local display for speed or %load, and diagnostic information. A control signal terminal block in the drive section connects to a user-supplied remote operator control station.

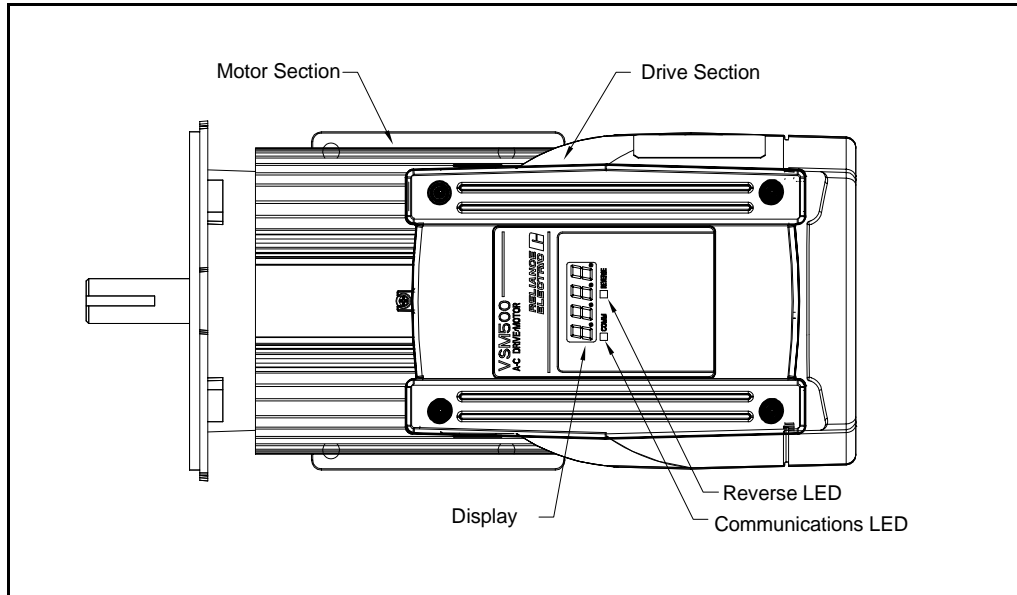

Figure 1.1 – VSM500 Standard Unit

1.1.1 Standard Unit Display Description

The four-character, seven-segment display shows the drive's output speed in RPM or %load, and displays active fault codes. Speed in RPM is the default display. To display %load, see section 7.4.

If a fault occurs, the unit displays the corresponding fault code. Refer to chapter 11 for more information about fault codes and corrective actions.

1.1.2 Standard Unit Reverse LED Description

The REVERSE LED indicates the requested direction of motor rotation:

LED Status	Definition
OFF	The requested direction of motor rotation is forward. (The VSM500 unit is shipped with the forward direction defined as CCW shaft rotation as viewed from the motor shaft end.)
ON	The requested direction of motor rotation is reverse. (The VSM500 unit is shipped with the reverse direction defined as CW shaft rotation as viewed from the motor shaft end.)

Note that if the motor is turning and you request a change to motor direction, the LED turns on or off immediately even though it may take some time for the motor to decelerate and begin turning in the opposite direction.

1.1.3 Standard Unit Communications LED Description

The communications LED (COMM) is used only with the VSM500 DeviceNet option. Refer to the VSM500 DeviceNet Option Board instruction manual, D2-3463, for more information about this LED.

1.2 VSM500 Local Operator Control Unit

The local operator control unit (see figure 1.2) provides local start, stop, forward, reverse, reset, and speed control functions. The controls replace the Start, Stop, Reset, and Forward / Reverse input signals at the terminal block. For local control, you do not wire to these inputs.

Version 3.0 and later units provide the option to control the unit from the terminal block instead of the local operator controls. In this case, you wire to the Start, Stop, Reset, and Forward / Reverse input signals at the terminal block. Note that the red  key can be used to stop the unit when the unit is set up for local (local operator controls) or remote (terminal block) control. See section 8.3.9, Start Mode Select, for a description of this option.

The local operator control unit receives its speed reference from the keypad (default) or the analog input terminals (user option). Refer to section 8.3.2 for more information.

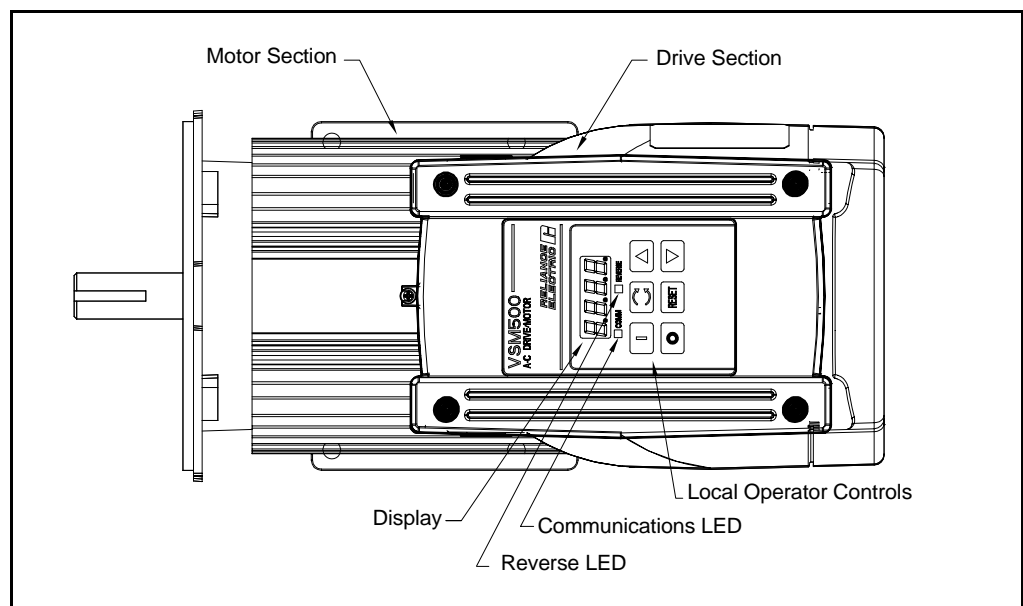

Figure 1.2 – VSM500 Local Operator Control Unit

1.2.1 Local Operator Control Unit Key Descriptions

Figure 1.3 shows each key's function.

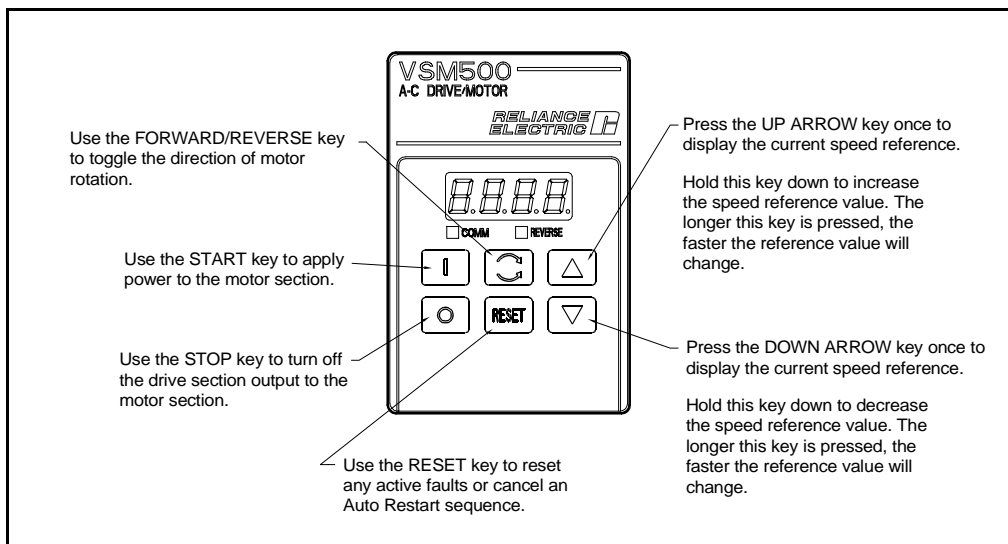

Figure 1.3 – Local Operator Controls Key Functions

1.2.2 Local Operating Control Unit Display Description

The four-character, seven-segment display shows output speed in RPM or %load, the current speed reference, and active fault codes. Speed in RPM is the default display. To display %load, see section 7.4.

If a fault occurs, the unit displays the corresponding fault code. Refer to chapter 11 for more information about fault codes and corrective actions.

1.2.3 Local Operating Control Unit Reverse LED Description

The REVERSE LED indicates the requested direction of motor rotation:











LED Status	Definition
OFF	The requested direction of motor rotation is forward. (The VSM500 unit is shipped with the forward direction defined as CCW shaft rotation as viewed from the motor shaft end.)
ON	The requested direction of motor rotation is reverse. (The VSM500 unit is shipped with the reverse direction defined as CCW shaft rotation as viewed from the motor shaft end.)

Note that if the motor is turning and the  key is pressed, the LED turns on or off immediately even though it may take some time for the motor to decelerate and begin turning in the opposite direction.



1.2.4 Local Operator Control Unit Communications LED Description

The communications LED (COMM) is used only with the VSM500 DeviceNet option. Refer to the VSM500 DeviceNet Option Board instruction manual, D2-3463, for more information about this LED.

1.2.5 Operating the Unit Using the Local Operator Controls

Desired Action	User Steps
Start the unit. ¹	Press the green  key.
Stop the unit.	Press the red  key.
Change the direction of motor rotation. ¹	Press the  key.
Clear faults.	Press the RESET key.
Decrease the speed reference. ²	Press the  key until the speed reference displayed is the desired value. The longer the  key is held down, the faster the value decreases.
Display the current speed reference	Press the  or  key once. The display returns to indicating speed in RPM or %load after three to five seconds. (Note that holding down either key will change the speed reference.)
Display the speed in RPM	No action required; speed in RPM is the default display based on status of terminal 12 (see section 7.4). If the  or  keys are not pressed for several seconds, the display returns to indicating actual motor speed in RPM.
Display %load	Close contact on terminal 12 (see section 7.4)
Increase the speed reference. ²	Press the  key until the speed reference displayed is the desired value. The longer the  key is held down, the faster the value increases.
Cancel Auto Restart sequence.	Press the RESET key.

¹If the unit is set up for terminal block control (see section 8.3.9), the  and  keys are not functional.

²If the unit is using a preset speed reference (see section 7.4.1) or terminal block speed reference (see section 8.3.2), pressing the  or  key will have no effect on unit operation.

Important: If the local operator controls are disconnected from or connected to the unit after power up, the unit will stop due to a non-resettable fault. Refer to chapter 11 for information about faults.

1.3 Option Kits

Table 1.2 lists the VSM500 option kits.

Table 1.2 – VSM500 Option Kits

Drive Input Rating	CE Filter Option Kit		DeviceNet Communication Option Kit
	Internal Mount	External Mount	
115V, 230V Single Phase	VSM-CE-1I	VSM-CE-1E	DNVSM500
230V, 460V Three Phase	VSM-CE-3I	VSM-CE-3E	

Step 2 - Plan the Installation



ATTENTION: Only qualified electrical personnel, familiar with the construction and operation of this equipment and the hazards involved, should install, adjust, operate, and/or service this equipment. Read and understand this instruction manual in its entirety before proceeding. Failure to observe this precaution could result in severe bodily injury or loss of life.

ATTENTION: This equipment is at line voltage when AC power is connected. Disconnect and lockout all ungrounded conductors of the AC power line before working on the unit. Failure to observe these precautions could result in severe bodily injury or loss of life.

ATTENTION: The user is responsible for conforming with all applicable local, national, and international codes. Failure to observe this precaution could result in personal injury and/or damage to, or destruction of, the equipment.

It is the user's responsibility to ensure that this equipment is installed properly according to this manual and in conformance with all applicable codes. Consult your local inspecting agency for information about any local, national, or international codes that may apply.

Review all installation and wiring instructions thoroughly before proceeding. Throughout the installation procedures, use figure 2.1 to locate wiring termination points and setup switches.

If the VSM500 unit installation must be in compliance with the European Community Electromagnetic Compatibility Standards, refer to appendix F before proceeding.

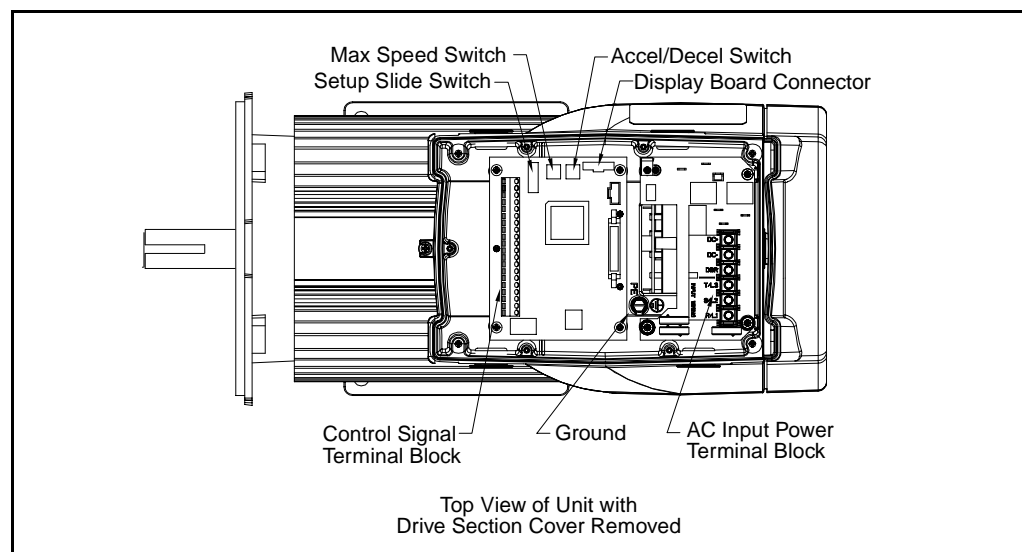

Figure 2.1 – Component Location

Planning the installation is necessary to ensure you have acceptable environmental and operating conditions for the unit. Read and follow the requirements given below before proceeding with the installation:

- Locate the unit where it will have unrestricted clearance as shown in figure 2.2.
- Locate the unit where it will be kept clean (away from oil, coolants, or airborne contaminants). The VSM500 unit has an IP54/Type 12 rating. An IP rating designates the enclosure's level of protection. The first number in the rating (5) indicates that the VSM500 unit is dust-resistant. The second number (4) indicates that the unit is splashproof.
- Mount the unit on a flat surface.
- Verify that the ambient temperature will remain between 0°C to 40°C (32°F to 104°F).
- Verify that the relative humidity will be between 5% and 95%, non-condensing.
- For installations above 1000 meters (3300 feet), refer to appendix A for derating guidelines.
- Verify that there will be adequate clearance for opening the cover. See figure 2.2.
- Verify that there will be adequate clearance for blower intake. See figure 2.2.

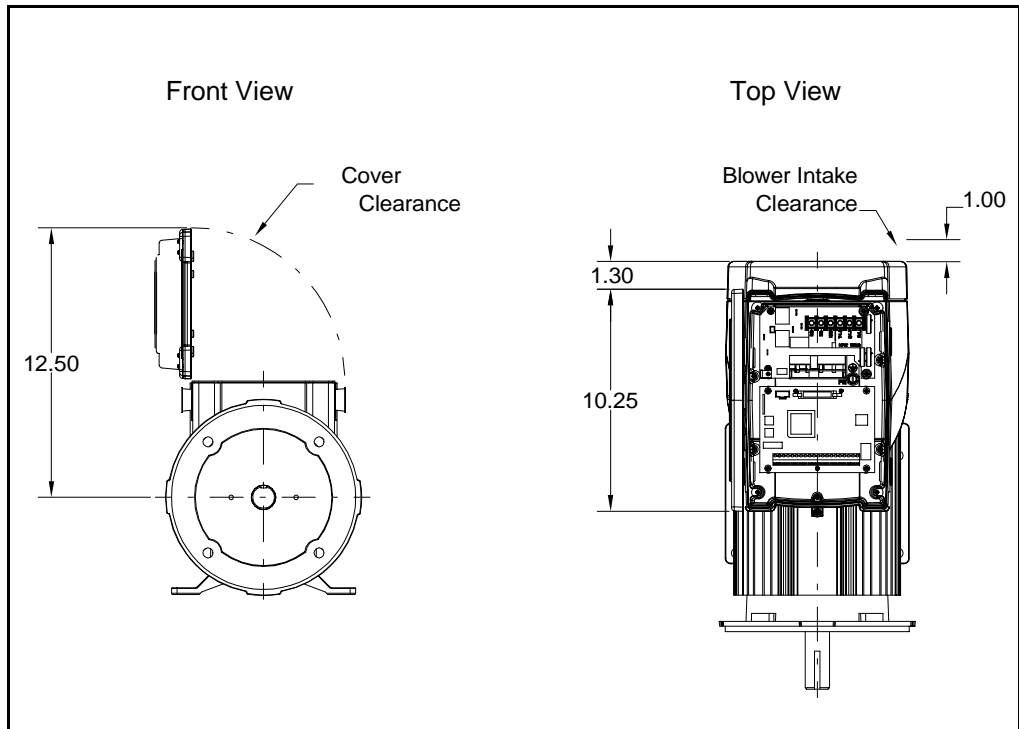

Figure 2.2 – Access Clearances

2.1 Wire Routing Guidelines

The VSM500 unit is shipped from the factory with plastic conduit plugs installed. These plugs must be removed. Before wiring, replace these plugs with appropriate 3/4-inch NPT connectors having a similar enclosure rating. After wiring, seal unused routing holes using permanent, user-supplied 3/4-inch NPT plugs. Seal all threaded connections. Route the power and control wiring as shown in figure 2.3.

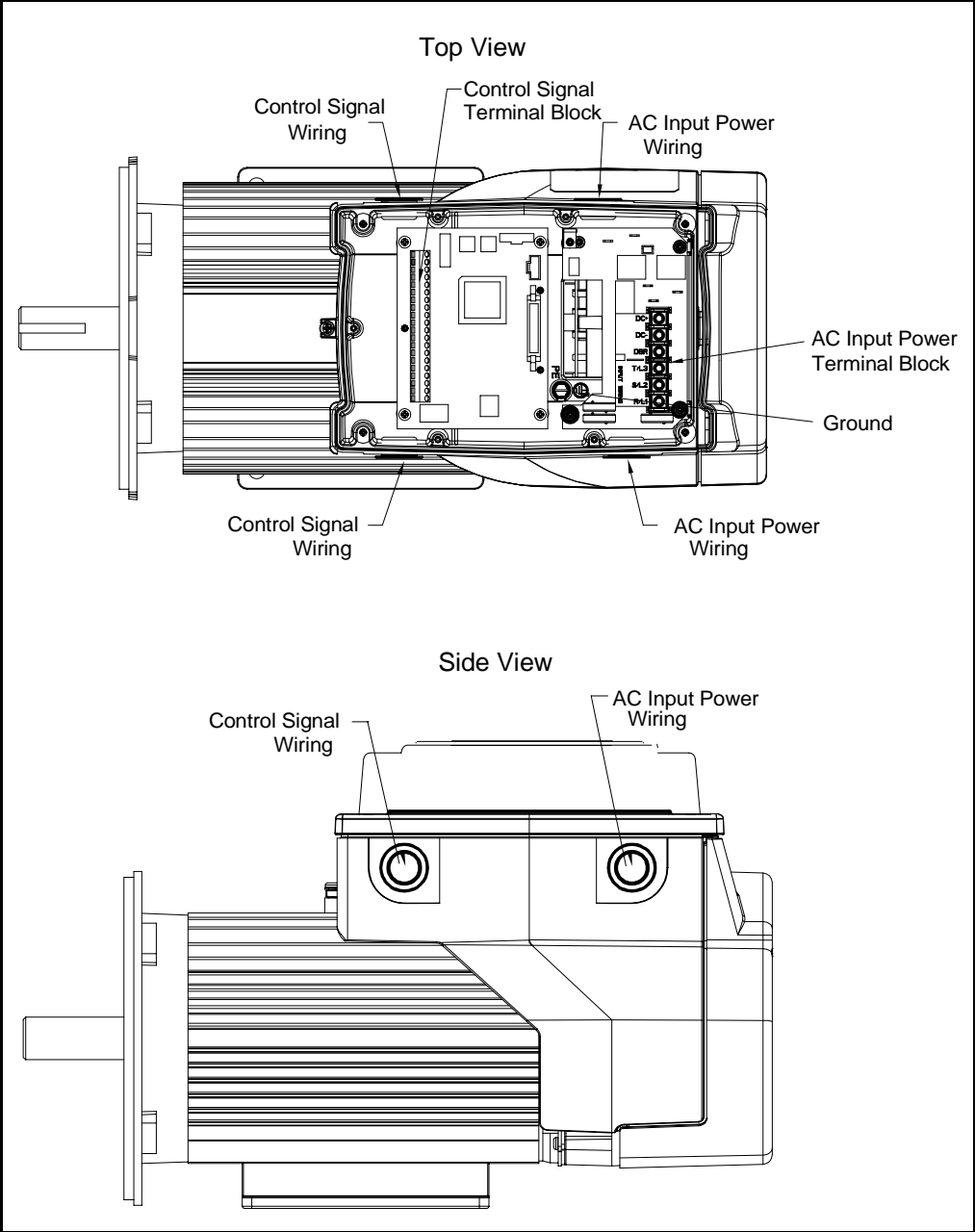

Figure 2.3 – Wire Routing Locations

2.2 Handling and Lifting Guidelines

Follow these handling and lifting guidelines:

- In the case of assemblies on a common base, carefully lift the assembly by a sling around the base or by other lifting means on the base.
- When designing the lifting means, take care to assure lifting in the intended direction.
- Do not lift the unit by the plastic blower cover.
- Do not use any lifting means under the drive section.
- Do not lift attached equipment by lifting the motor.
- Do not use the VSM500 unit as a step.

Step 3 - Mount the Unit

Mount the unit on a foundation sufficiently rigid to prevent excessive vibration. The unit may be mounted at any orientation. After carefully aligning the VSM500 unit with the driven machinery, bolt securely in place.

When the unit is mounted vertically, it may be necessary to use additional guards to prevent foreign objects from falling into the motor openings and striking rotating parts.

Mounting dimensions are provided on the following pages of this chapter.

3.1 Mounting Guidelines for Reliance Face-Mounted Motors

Use the following guidelines when mounting Reliance 56C and 140C face-mounted motors:

- Before mounting a C-face motor to the mating flange, be sure both surfaces and all mounting holes are smooth and free of debris.
- When mounting into a quill-type reducer, make sure the input and output shafts are coated with an anti-seize compound suitable for the application.
- When mounting through a flexible coupling, make sure that there is adequate clearance between the driven equipment shaft, the coupling interface, and the motor shaft. Insufficient clearance may result in binding of the shafting and premature bearing failure.
- Always slide the motor tenon into the mating flange to its full depth before tightening the mounting bolts. Do not allow the motor to hang by the shaft extension while assembling it to the driven equipment (for example, a quill input gear case) as this may bend or crease the shaft and damage any seals that are present.
- Make sure to use the proper mounting bolts. For 56C and 140C motors, these should be 9.5 mm (0.38 in) and sized for length such that engagement into the motor flange does not exceed 14.3 mm (0.563 in).

For example, a gearcase with a 9.5 mm (0.38 in) flange thickness requires a bolt that is 9.5 mm (0.38 in) + 14.3 mm (0.56 in). That is, 23.8 mm (0.94 in) should be the maximum bolt length. Since 23.8 mm (0.94 in) is not a standard bolt length, a 22.2 mm (0.88 in) bolt or a 25.4 mm (1.0 in) bolt with a lock washer can be used.

Important: Using a bolt that is too long may cause damage to the motor resulting in premature failure and/or a loose assembly.

3.2 Mounting Dimensions for NEMA Frames

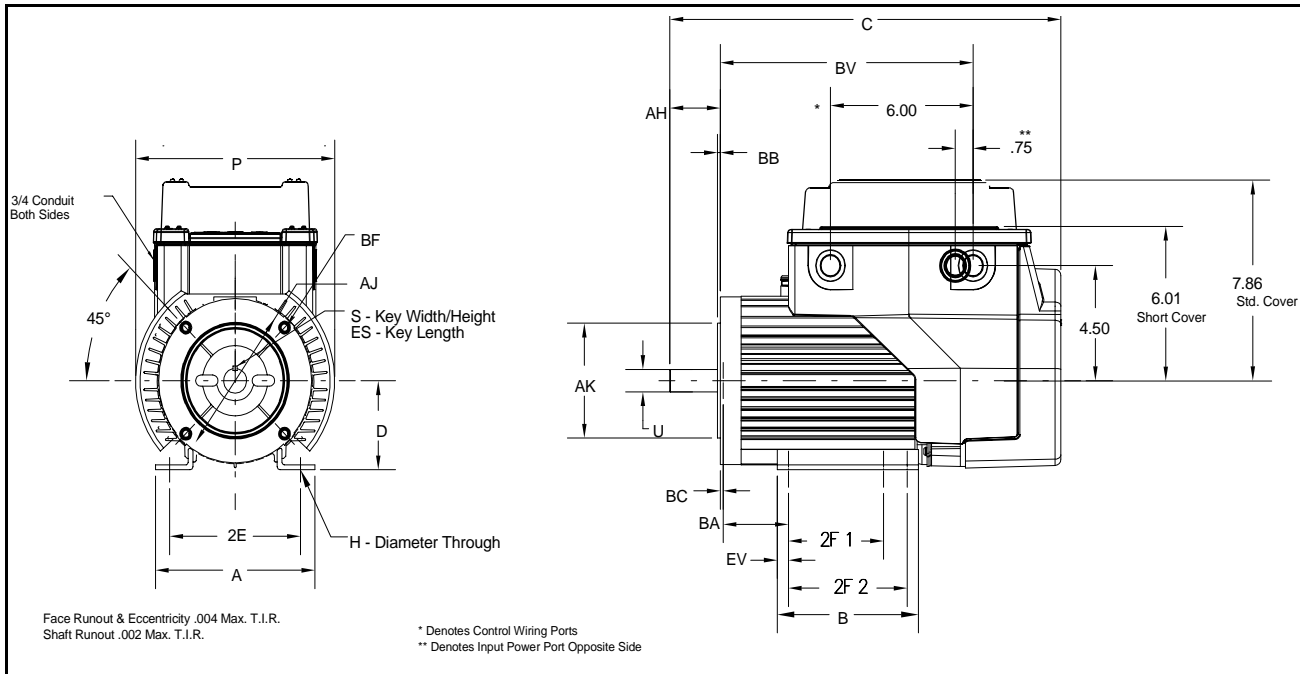

Figure 3.1 – NEMA Frame Mounting Dimensions

Frame Size	Dimensions in inches (mm)										
	A	2E	H	D	BF	AJ	AK	U	AH	S	ES
56C	6.71 (170)	5.50 (140)	0.34 (8.6)	3.50 (89)	3/8-16	5.88 (149)	4.50 (114)	0.625 (15.9)	2.06 (52)	.19 SQ (4.8)	1.25 (32)
143TC 145TC	6.71 (170)	5.50 (140)	0.34 (8.6)	3.50 (89)	3/8-16	5.88 (149)	4.50 (114)	0.875 (22.3)	2.12 (54)	.19 SQ (4.8)	1.25 (32)
182TC 184TC	8.50 (216)	7.50 (191)	0.34 (8.6)	4.50 (114)	1/2-13	7.25 (184)	8.50 (216)	1.125 (28.6)	2.62 (67)	.25 SQ (6.4)	1.50 (38)

Frame Size	Dimensions in inches (mm)									
	BC	BB	BA	B	2F 1	2F 2	EV	C	P	BV
56C	-0.19 (-4.8)	0.12 (3.0)	2.75 (70)	6.50 (165)	3.00 (76)	5.00 (127)	0.47 (12)	15.90 (404)	8.38 (213)	10.14 (258)
143TC	0.12 (3.0)	0.12 (3.0)	2.75 (70)	6.50 (165)	4.00 (102)	5.00 (127)	0.47 (12)	16.46 (418)	8.38 (213)	10.14 (258)
145TC	0.12 (3.0)	0.12 (3.0)	2.75 (70)	6.50 (165)	4.00 (102)	5.00 (127)	0.47 (12)	15.96 (405)	8.38 (213)	10.64 (270)
182TC	0.12 (3.0)	0.25 (6.4)	3.50 (89)	6.50 (165)	4.50 (114)	5.50 (140)	0.50 (13)	18.75 (476)	8.80 (224)	12.39 (315)
184TC	0.12 (3.0)	0.25 (6.4)	3.50 (89)	6.50 (165)	4.50 (114)	5.50 (140)	0.50 (13)	19.75 (502)	8.80 (224)	13.39 (340)

Step 4 - Install External Components

Install external components using the guidelines in the following sections.

4.1 Installing an AC Input Disconnect



ATTENTION: The NEC and CEC require that an input disconnect be provided in the incoming power lines. Failure to observe this precaution could result in severe bodily injury or loss of life.

An AC input disconnect must be provided in the incoming power lines in accordance with NEC/CEC guidelines.

4.2 Installing Branch Circuit Protection



ATTENTION: The NEC/CEC requires that upstream branch protection be provided to protect input power wiring. The input fuse ratings listed in table 4.1 are applicable for one VSM500 unit per branch circuit. No other load can be applied to that fused branch circuit. Failure to observe this precaution could result in severe bodily injury or loss of life.

Install the required, user-supplied branch circuit protection fuses according to NEC/CEC guidelines. Refer to table 4.1 for recommended fuse ratings.

Table 4.1 – Required AC Branch Circuit Protection

Model Number	Input Voltage	Unit HP	NEC Amps Input	
			Input Current	Fuse Rating ¹
1_X_4_1_	460 VAC	1 HP	2.3 A	3.5 A
2_X_4_1_	460 VAC	2 HP	3.7 A	6.0 A
3_X_4_1_	460 VAC	3 HP	5.7 A	9.0 A
5_X_4_1_	460 VAC	5 HP	9.0 A	15.0 A
1_X_2_1_	230 VAC	1 HP	4.5 A	7.0 A
2_X_2_1_	230 VAC	2 HP	7.6 A	12.0 A
1_X_3_1_	230 VAC (1-Phase)	1 HP	5.8 A	9.0 A
2_X_3_1_	230 VAC (1-Phase)	2 HP	14.0 A	20.0 A
1_X_1_1_	115 VAC	1 HP	14.0 A	20.0 A

¹Recommended fuse type: UL Class J or CC, 600 V, time delay.

4.3 Installing Input Isolation Transformers



ATTENTION: Distribution system capacity above the maximum recommended system KVA (100 KVA for 460 VAC three-phase, 5% impedance) requires using an isolation transformer, a line reactor, or other means of adding similar impedance. Failure to observe this precaution could result in damage to, or destruction of, the equipment.

Depending upon the requirements of the application, the VSM500 unit may require input isolation transformers to help eliminate the following:

- Damaging AC line voltage transients from reaching the VSM500 unit.
- Line noise from the VSM500 unit being fed back to the incoming power source.

An isolation transformer or line reactors of 3% drive input impedance should be used between the distribution source and the VSM500 unit in situations such as the following:

- The power distribution system feeding the VSM500 unit contains power factor correction capacitors.
- The power distribution system feeding the VSM500 unit connects with heavy industrial equipment that causes instantaneous line distribution shorts such as arc welders, line-commutated thyristor converters, or line-started AC induction motors greater than 50 HP (37 KVA).
- The distribution transformer is rated more than 100 KVA for 460 VAC with less than 5% impedance.
- The distribution system is prone to frequent power outages or transient power interruptions or significant voltage spikes.

Refer to table 4.2 for the appropriate line reactor for your unit.

Table 4.2 – Input Line Reactors

VSM500 Unit		Input Line Reactor		
HP	Input Voltage	Inductance	Rated Amps	Reliance Part No.
1	460V, 3-Phase	6.5 mH	4.0	608895-63D
2	460V, 3-Phase	3.0 mH	8.0	608895-63F
3	460V, 3-Phase	2.5 mH	12.0	608895-63H
5	460V, 3-Phase	1.5 mH	18.0	608895-63K
1	230V, 3-Phase	1.5 mH	8.0	608895-63E
2	230V, 3-Phase	0.8 mH	18.0	608895-63J

A power-disconnecting device must be installed between the power line and the primary of the transformer. If the power-disconnecting device is a circuit breaker, the circuit breaker trip rating must be coordinated with the in-rush current (10 to 12 times full load current) of the transformer.

Step 5 - Wire AC Power to the Unit and Ground the Unit



ATTENTION: If the distribution system capacity exceeds the unit's maximum symmetrical fault short-circuit current of 10,000 amps, additional impedance should be added to the AC line supplying the unit to limit available current in the event of a fault. Failure to observe this precaution could result in severe bodily injury or loss of life.

ATTENTION: The unit is intended to be commanded by control input signals that will start and stop the motor. A device that routinely disconnects then reapplies input power to the unit for the purpose of starting and stopping the motor should not be used. If it is necessary to use this method for starting and stopping, or if frequent cycling of power is unavoidable, make sure that it does not occur more than once a minute. Failure to observe this precaution could result in damage to equipment.

Observe the following guidelines when wiring AC power:

- The terminal block accepts up to 3.31 mm² (12 AWG) wire.
- The recommended tightening torque is 1.3 Nm (12 in-lb).
- Verify that the input power to the unit corresponds to the unit voltage and frequency and that the input supply is of sufficient capacity to support the input current requirements. Refer to appendix A, Technical Specifications.
- Size the AC line conductors for the unit rating and in accordance with all applicable local, national, and international codes.

Use the following procedure to wire AC power to the unit. Grounding instructions are provided in section 5.1.

Step 1. Remove the cover by loosening the four cover screws. Note that the display ribbon cable is designed to disconnect from the main unit when the cover is removed as shown in figure 5.1.

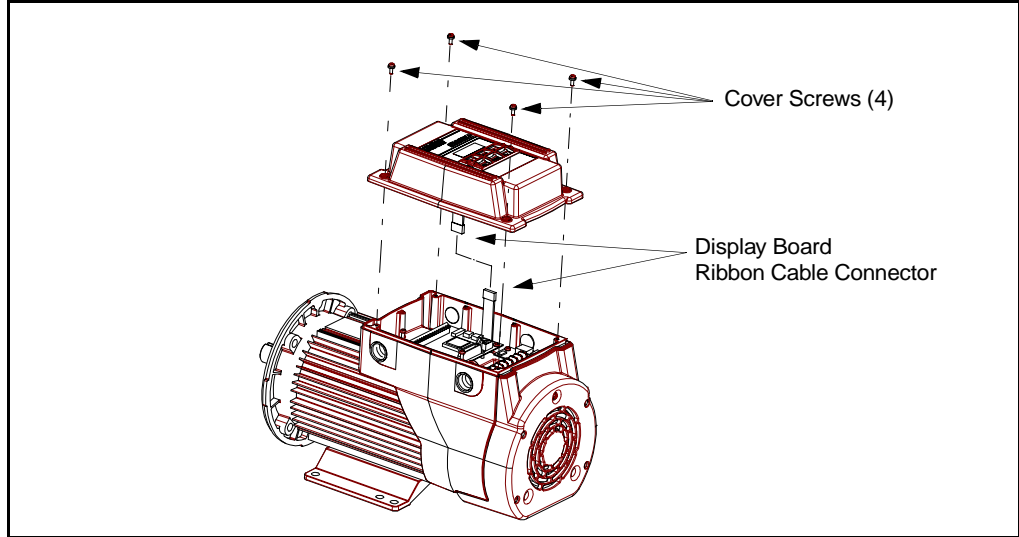

Figure 5.1 – Removing the Cover

Step 2. **For three-phase input:** Connect the incoming three-phase AC line to terminals R, S, and T, as shown in figure 5.2.

For single-phase input: Connect the incoming single-phase AC line to any two of the terminals R, S, T shown in figure 5.2.

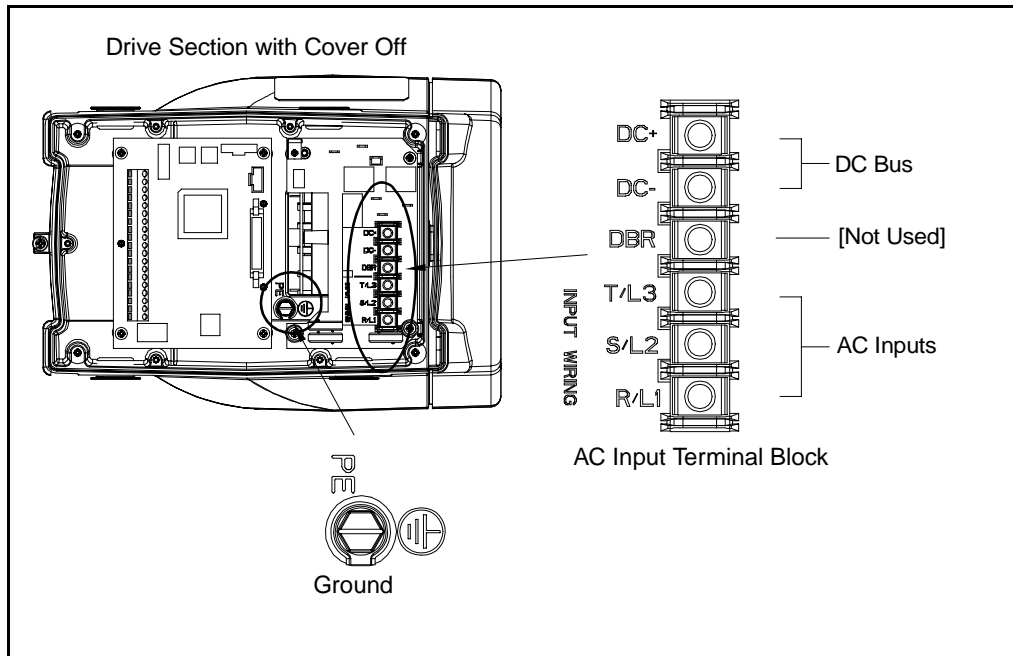

Figure 5.2 – AC Input Power Connections

5.1 Grounding the Unit



ATTENTION: The user is responsible for conforming with all local, national, and international codes applicable to the grounding of this equipment. Failure to observe this precaution could result in severe bodily injury or loss of life.

Connect the ground wire brought in with the incoming AC power to the unit's grounding screw (see figure 5.2). This grounding conductor must run unbroken from the unit to earth ground. The recommended tightening torque is 2.6 Nm (32 in-lb).

Step 6 - Install an Emergency Stop



ATTENTION: The user must provide an external, hardwired emergency stop circuit outside of the VSM500 unit circuitry. This circuit must disable the system in case of improper operation. Uncontrolled machine operation may result if this procedure is not followed. Failure to observe this precaution could result in bodily injury.

Depending upon the requirements of the application, the VSM500 unit can be set up to provide either a coast-to-rest (default) or a ramp-to-rest (user option) operational stop. The unit's Function Loss input provides an additional coast-to-rest operational stop.

In addition to the operational stop, the user must provide a hardwired emergency stop external to the unit. The emergency stop circuit must contain only hardwired electromechanical components. Operation of the emergency stop must not depend on electronic logic (hardware or software) or on the communication of commands over an electronic network or link.

6.1 Compliance with Machinery Safety Standard EN 60204-1: 1992

This section applies to users who must comply with EN 60204-1: 1992, Electrical equipment of industrial machines, part 9.2.5.4, Emergency Stop.

The VSM500 coast-to-rest stop is a category 0 operational stop. The ramp-to-rest stop is a category 1 operational stop.

The required external hardwired emergency stop must be either a category 0 or 1 stop, depending on the user's risk assessment of the associated machinery. In order to fully comply with EN 60204-1: 1992, part 9.2.5.4, at least one of the system's stop methods must be a category 0 stop.

Step 7 - Wire the Control Signal Terminal Block

The following sections describe how to wire the control signal terminal block shown in figure 7.1.

Refer to either figure 7.2 (standard units or local operator control units set up for terminal block control) or figure 7.3 (local operator control units) before you begin wiring. These figures show typical wiring connections and the sections in this chapter where the signals are described in detail.

Note the following when wiring the terminal block:

- The terminal block is isolated from the input power.
- Route the control wires separately from the power wires.
- The terminal block accepts 0.326 mm² (22 AWG) through 3.31 mm² (12 AWG) wire.
- The maximum lead length is 300 meters (1000 ft).
- The maximum tightening torque is 0.8 Nm (7 in-lb).

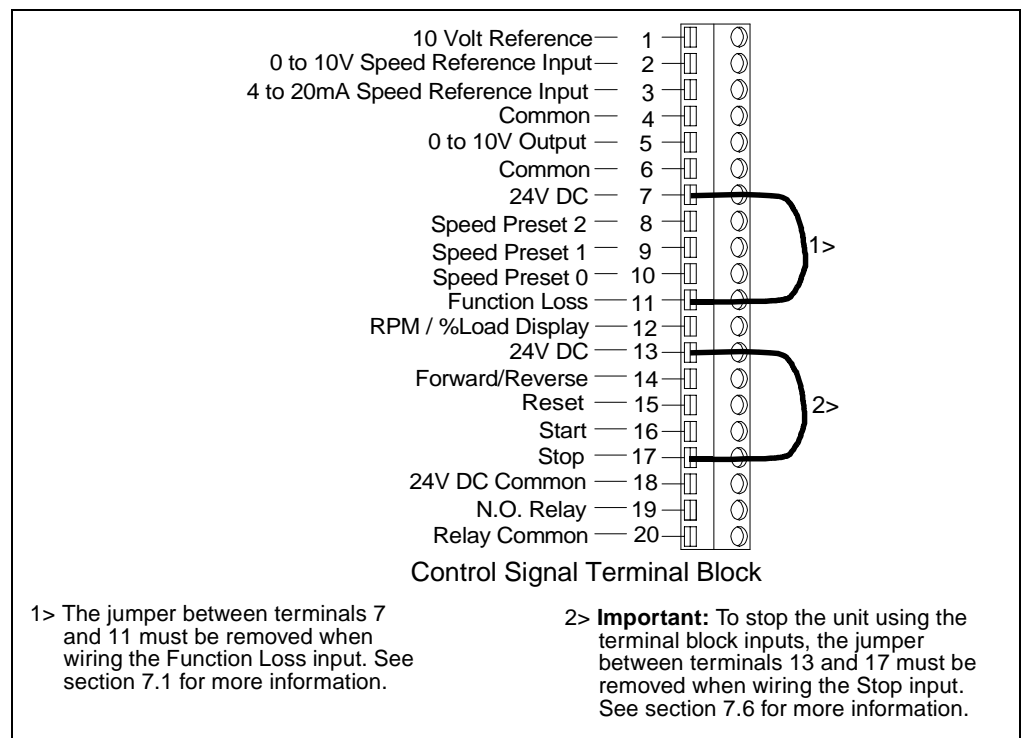

Figure 7.1 – Control Signal Terminal Block

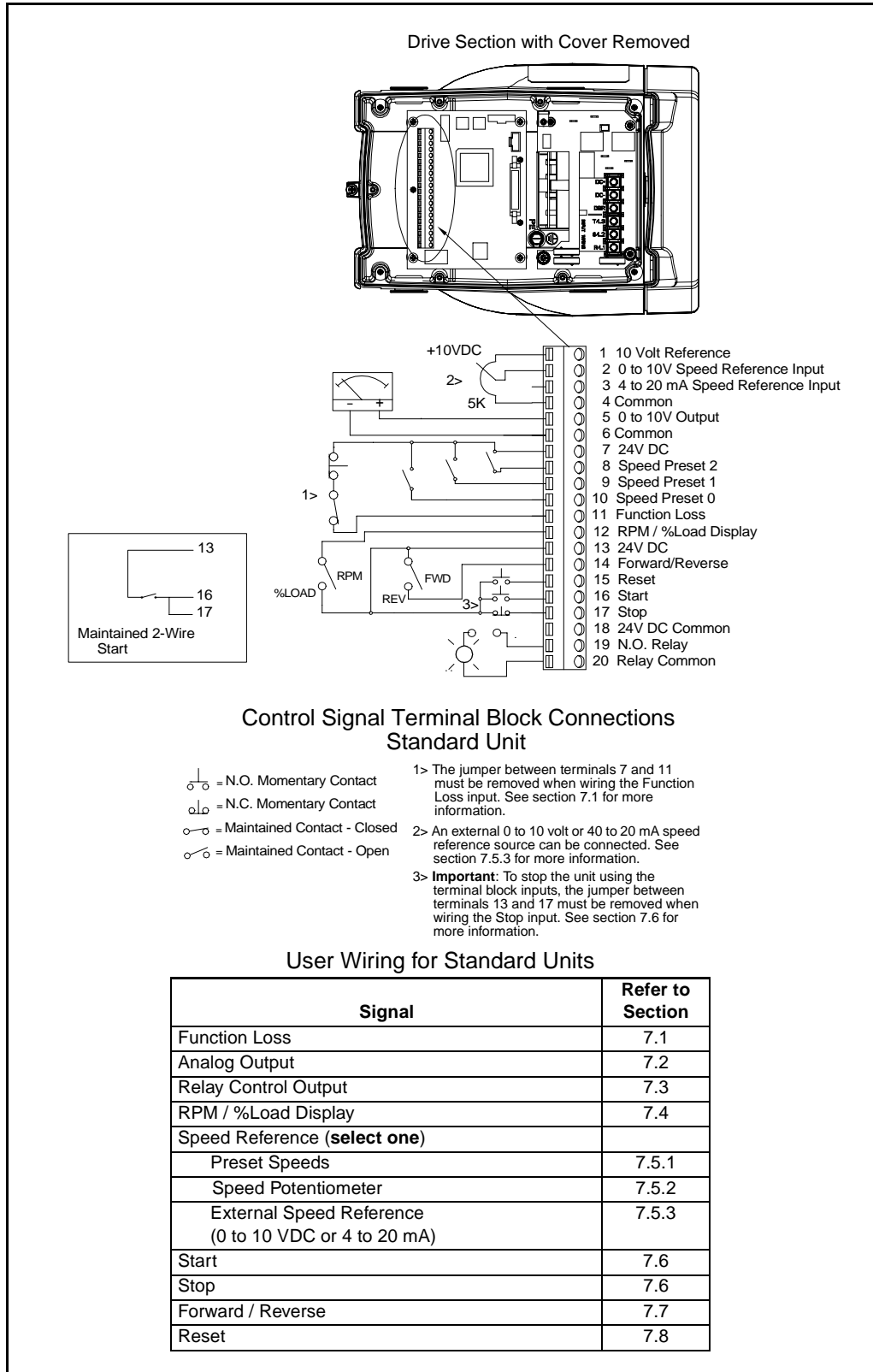

Figure 7.2 – Typical Control Signal Connections for Standard Units and Local Operator Control Units Set Up for Terminal Block Control

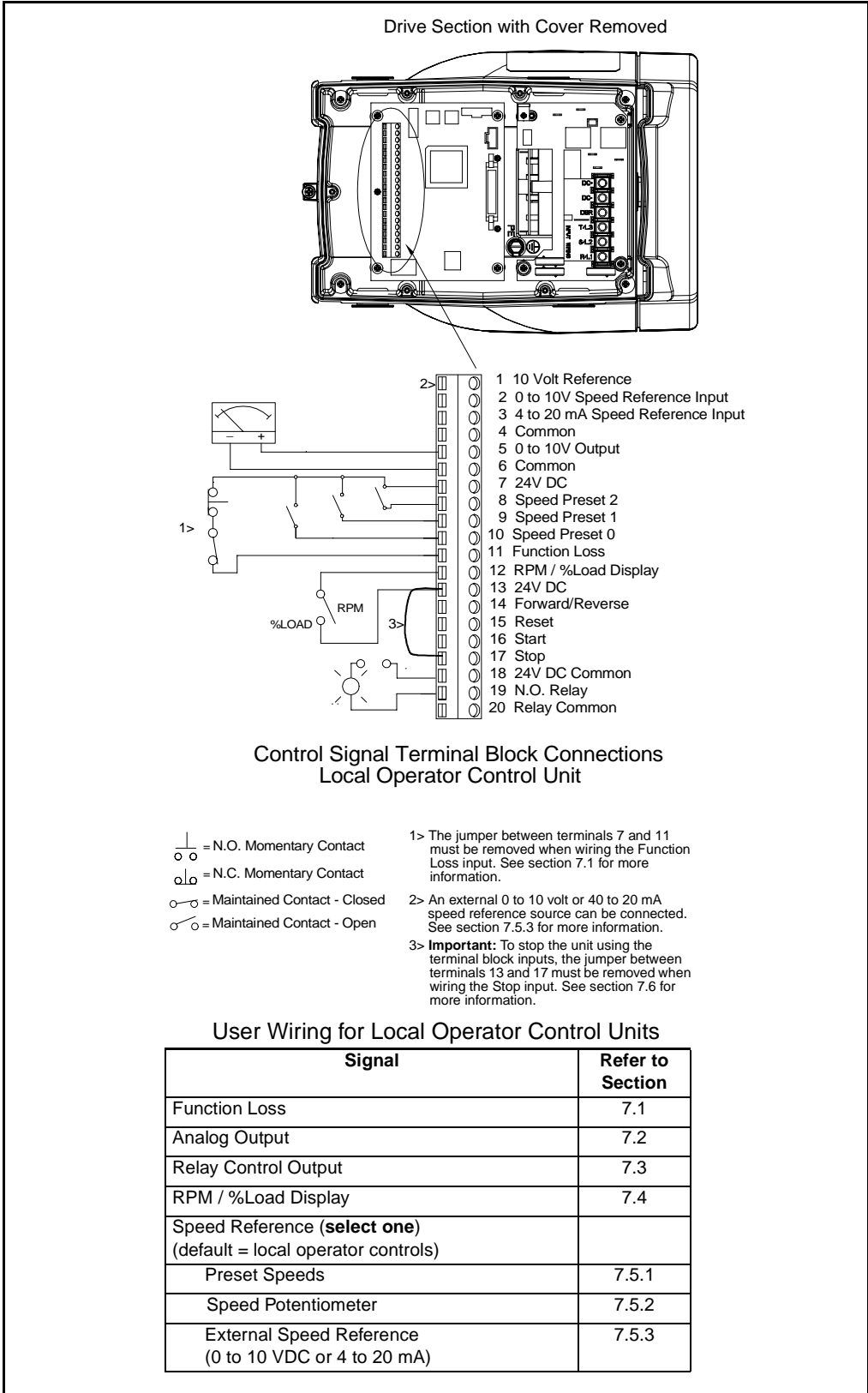

Figure 7.3 – Typical Control Signal Connections for Local Operator Control Units

7.1 Wiring Function Loss

For the unit to run, you must maintain a signal at the Function Loss input (the connection between control terminals 7 and 11). If the Function Loss signal is not present, the unit turns off the power devices and coasts to rest. To restart the unit, you must restore the Function Loss signal, clear any faults, and reassert the Start command.

The unit ships from the factory with a jumper between terminals 7 and 11 which provides the Function Loss signal. The Function Loss input should be wired in series with the drive's external interlocks as shown in figure 7.4. In this case, remove the jumper before making the connections.

Important: Function Loss provides an operational stop. It does not fulfill the requirements of an emergency stop. Refer to chapter 6 for information regarding emergency stop requirements.

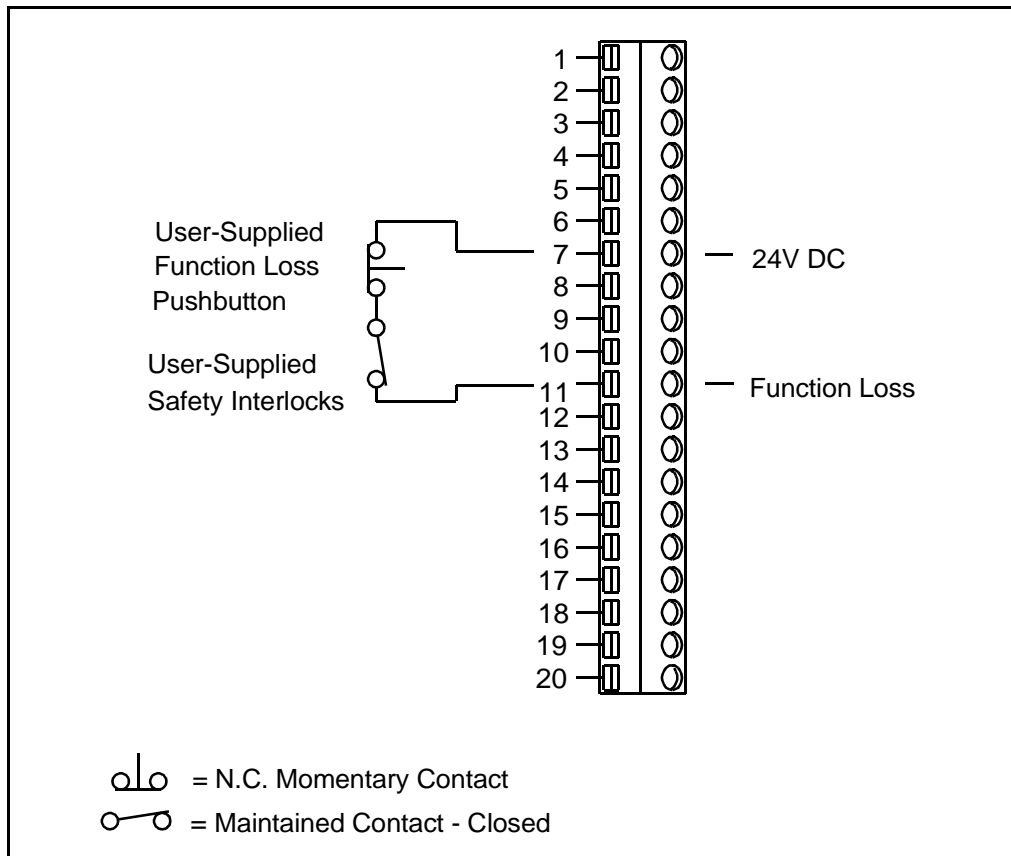

Figure 7.4 – Function Loss Control Wiring

7.2 Wiring the Analog Output

The analog output provides a 0 to 10 VDC signal to a user-supplied metering device. This output indicates speed (default) or %load (user option), based on the status of input terminal 12.

If you select speed indication, 0 to 10 V = 0 to the maximum speed as defined by the maximum speed rotary switch. (Refer to chapter 8 for a description of the rotary switch.)

If you select %load indication, 0 to 10 V = 0 to 200% load.

Wire to the analog output as shown in figure 7.5.

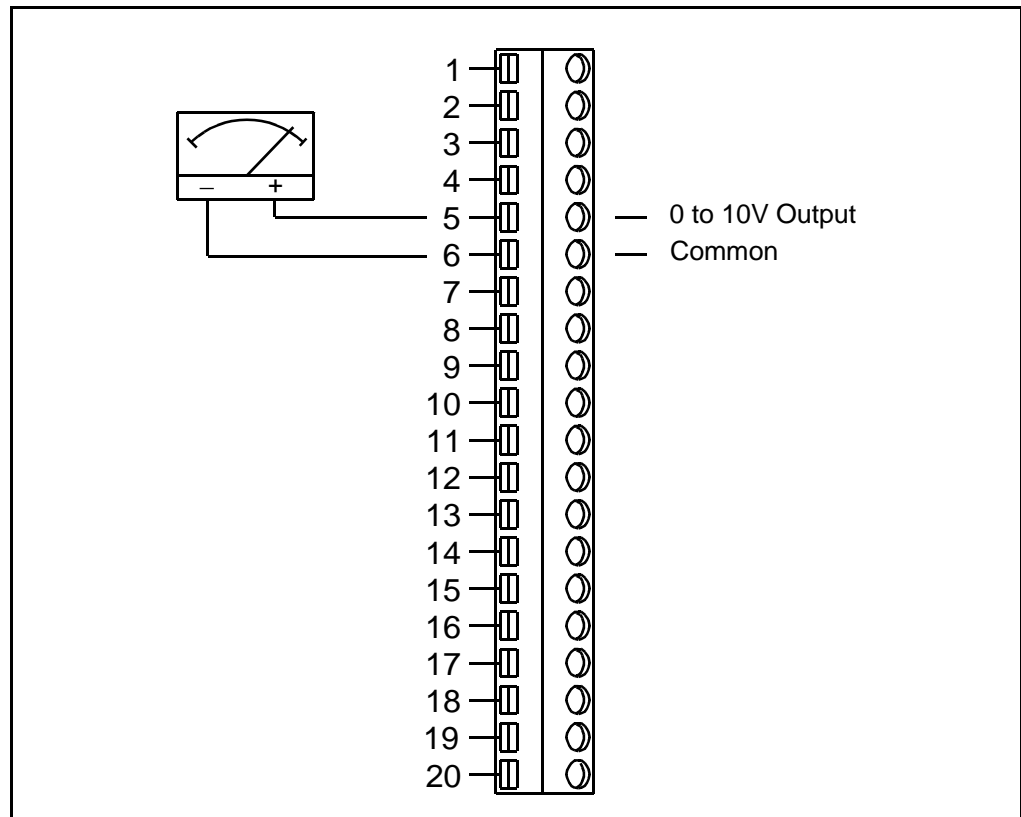

Figure 7.5 – Analog Output Wiring

7.3 Wiring the Relay Control Output

A single form A relay on the terminal block can be used to indicate the unit is running (default) or has faulted (user option) based on the setup slide switch setting. Refer to the setup slide switch description in chapter 8.

Wire to the relay control output as shown in figure 7.6.

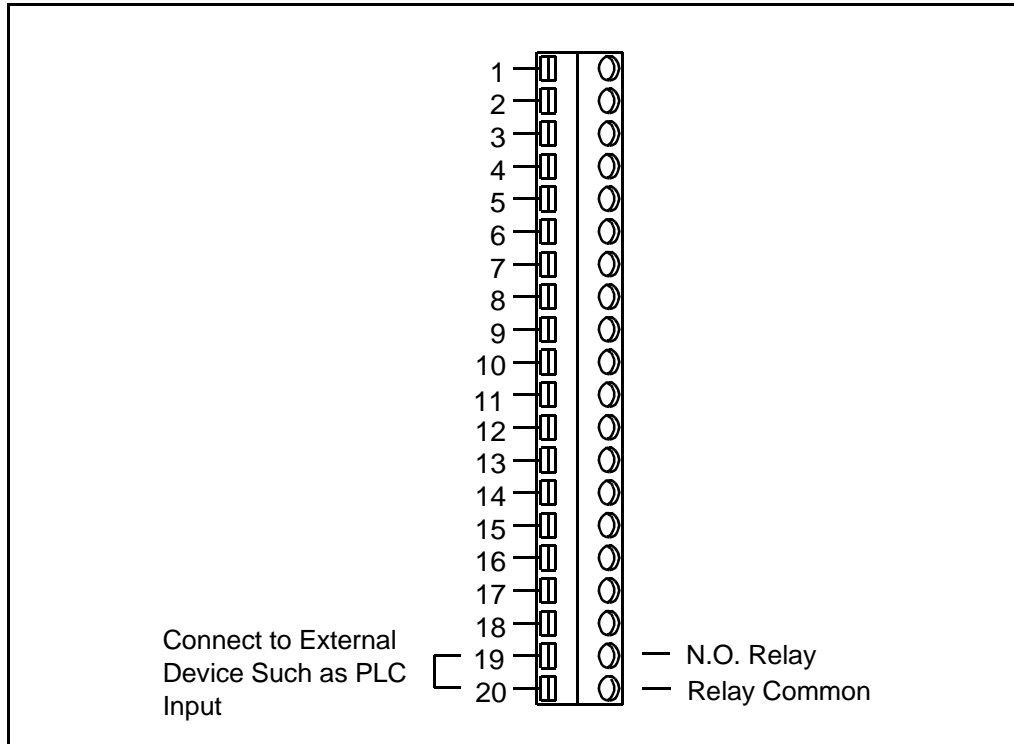

Figure 7.6 – Relay Control Output Wiring

7.4 Wiring RPM or %Load Display

The RPM or %Load Display input (control terminal 12) selects the type of information displayed by the analog output and the built-in display, speed in RPM or %load. Wire a switch between control terminals 12 and 13 as shown in figure 7.7.

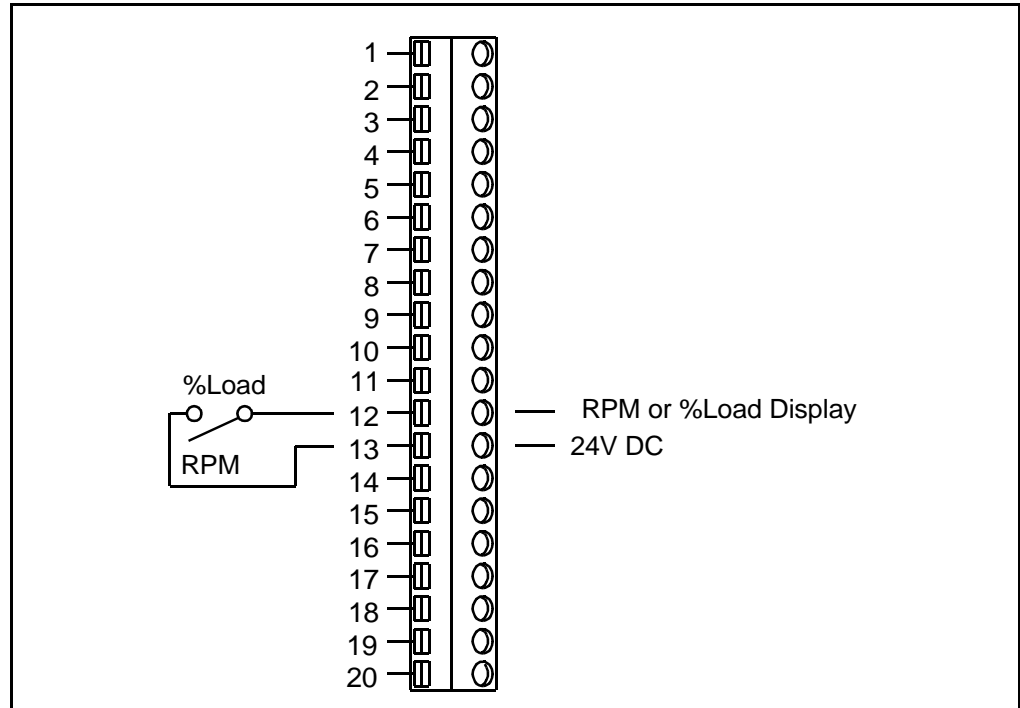

Figure 7.7 – RPM or %Load Display Wiring

7.5 Wiring the Speed Reference

The **standard VSM500 unit** provides two motor speed reference options:

- Seven preset speeds
- An external 0 to 10 VDC or 4 to 20 mA speed reference source

The **VSM500 unit with local operator controls** provides three motor speed reference options:

- The local operator controls (using the ▲ ▼ keys)
- Seven preset speeds (the ▲ ▼ keys are not used)
- An external 0 to 10 VDC or 4 to 20 mA speed reference source (the ▲ ▼ keys are not used)

Select the option that is the most suitable for your application. The following sections provide wiring information for each option except the local operator controls. Refer to section 1.2 for information on the local operator controls.

7.5.1 Wiring the Preset Speed Inputs

Control terminals 8, 9, and 10 select seven preset speeds as shown in table 7.1. Note that if you select a preset speed that is greater than the maximum speed setting (based on the rotary switch setting), the unit uses the maximum speed setting value.

Important: Slide switch position 8 defines whether terminals 8, 9, and 10 are used as presets (default) or to define the unit's minimum speed (user option). Refer to section 8.3.8 for information about using terminals 8, 9, and 10 to select minimum speed.

Table 7.1 – Fixed Preset Speed Selections

Terminal 8 Status	Terminal 9 Status	Terminal 10 Status	Selected Speed Reference	
			Standard Unit	Local Operator Control Unit
Open	Open	Open	Analog speed reference	Local operator control
Open	Open	Closed	Preset 1 - 300 RPM (10 Hz)	
Open	Closed	Open	Preset 2 - 600 RPM (20 Hz)	
Open	Closed	Closed	Preset 3 - 900 RPM (30 Hz)	
Closed	Open	Open	Preset 4 - 1200 RPM (40 Hz)	
Closed	Open	Closed	Preset 5 - 1500 RPM (50 Hz)	
Closed	Closed	Open	Preset 6 - 1800 RPM (60 Hz)	
Closed	Closed	Closed	Preset 7 - 2100 RPM (70 Hz)	

To use the preset speeds to set the speed reference, wire to terminals 8, 9, and 10 as shown in figure 7.8.

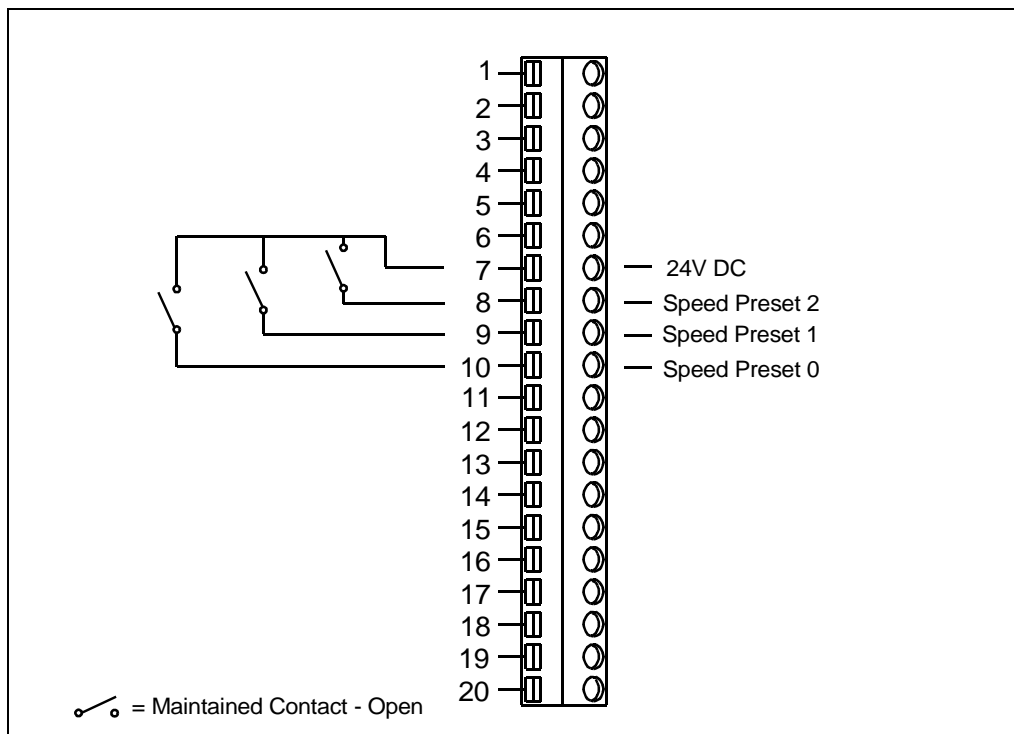

Figure 7.8 – Preset Speed Input Wiring

7.5.2 Wiring the Speed Reference Signal Potentiometer

Control terminal 1 provides a 10 VDC reference for use with the user-supplied 5 k Ω potentiometer. Perform the following procedure to wire the potentiometer as the speed reference (refer to figure 7.9):

- Step 1. Mount the speed reference potentiometer at an appropriate operator-accessible location, less than 300 meters (1000 feet) from the VSM500 unit.
- Step 2. Connect one end of the potentiometer to control terminal 1 (10V reference) and the other end to control terminal 4 (signal common).
- Step 3. Connect the potentiometer's wiper to control terminal 2 (speed reference input).

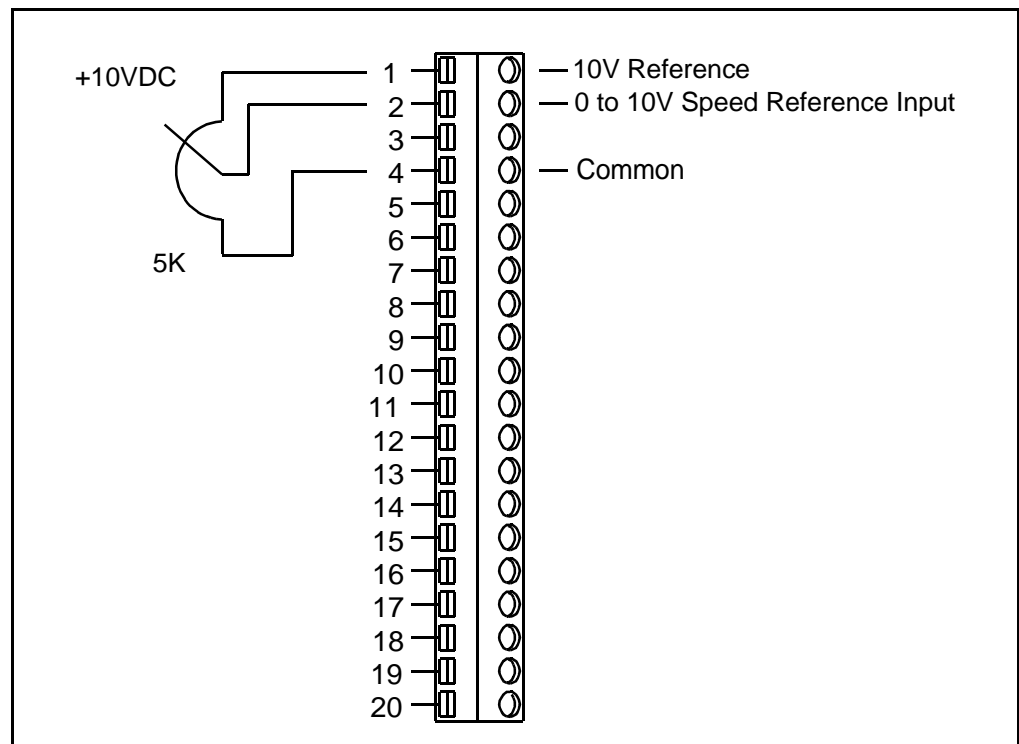

Figure 7.9 – Speed Reference Potentiometer Wiring

7.5.3 Wiring an External Speed Reference (0 to 10 VDC or 4 to 20 mA)

The terminal block provides both 0 to 10 VDC and 4 to 20 mA inputs. Use only one of these inputs for the external speed reference. The other input must remain unconnected.

0 to 10 VDC External Speed Reference

To use an external 0 to 10 VDC signal to set the speed reference, connect the signal leads as shown in figure 7.10. 0 to 10 VDC = minimum speed to maximum speed.

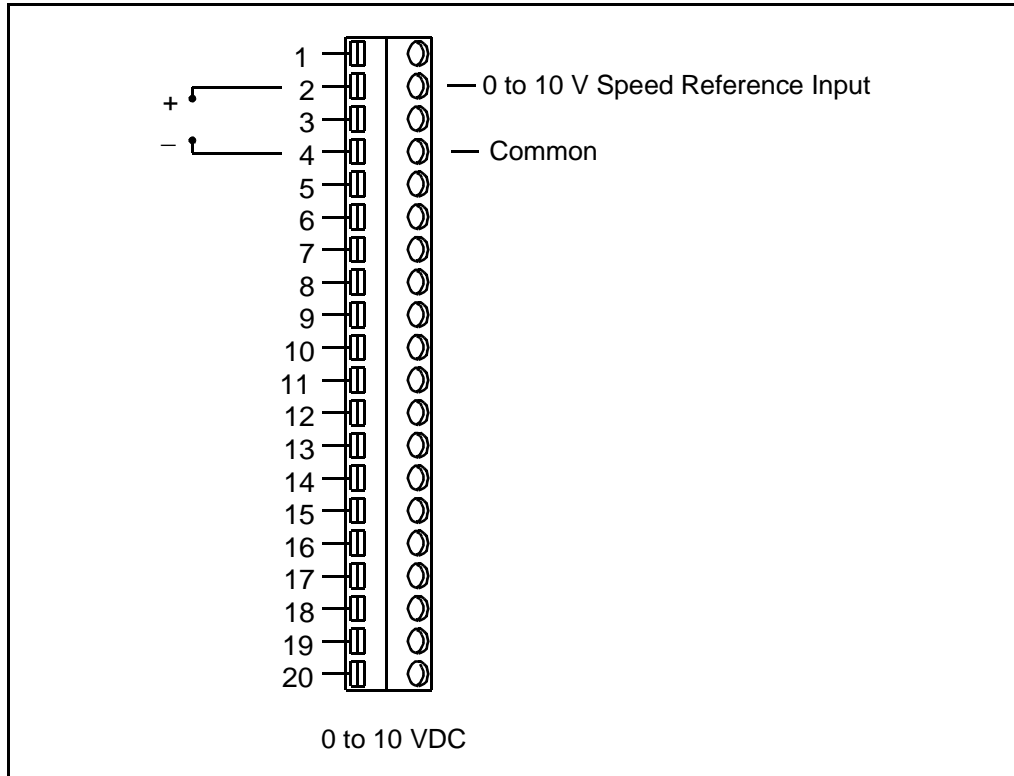

Figure 7.10 – 0 to 10 VDC External Speed Reference Wiring

4 to 20 mA External Speed Reference

To use an external 4 to 20 mA signal to set the speed reference, connect the signal leads as shown in figure 7.11. 4 to 20 mA = minimum speed to maximum speed.

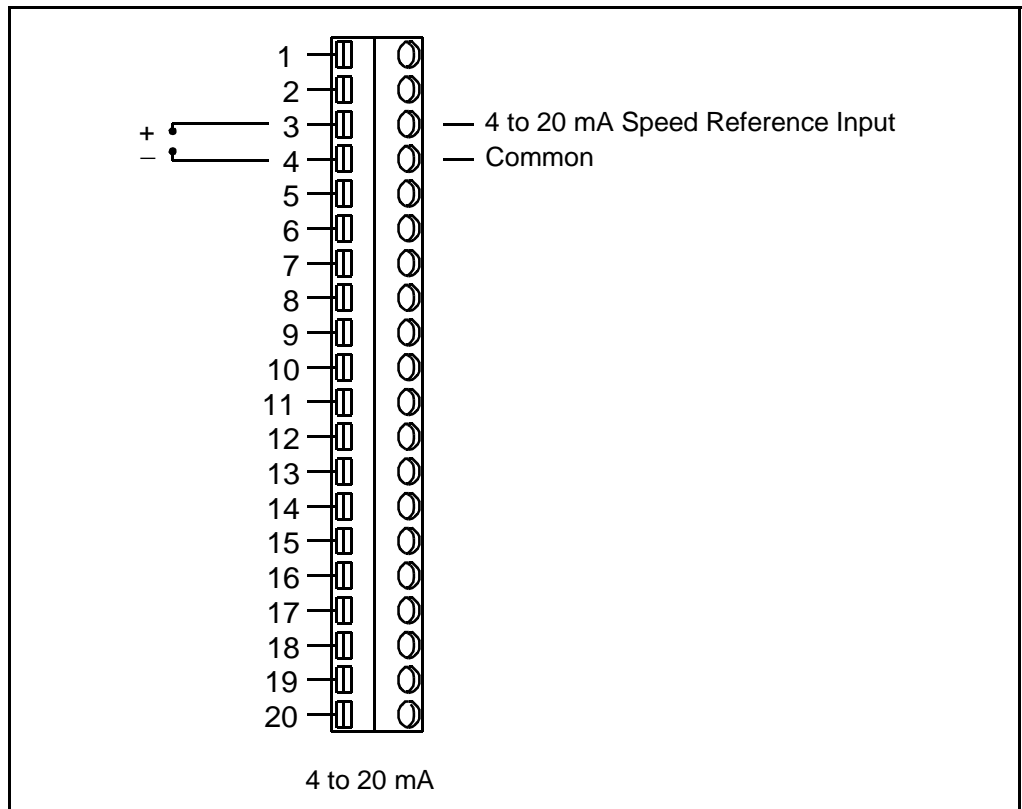

Figure 7.11 – 4 to 20 mA External Speed Reference Wiring

7.6 Wiring Start / Stop Control

Important: This applies only to standard units and local operator control units set up for terminal block control (setup slide switch position 9 = ON, see section 8.3.9).

The system looks for an open-to-closed transition at the Start input before starting the unit unless you have the Power-Up Start switch (setup slide switch 1, see section 8.3.1) set to ON. If you use a maintained start device and power to the unit is lost, you must open and reclose the start device before the unit will start again. Both the Stop and the Function Loss input signals must be present and there must be no active faults for the unit to start.

In order for the unit to run, you must maintain a signal at the Stop input. If the signal is interrupted, the unit coasts to rest (default) or ramps to rest (user option). To restart the unit, you must restore the signal and reassert the Start input.

The unit ships from the factory with a jumper on the Stop input terminals (terminals 13 and 17) which permits the unit to be started. To stop the unit using the terminal block inputs, you must remove the factory jumper and install appropriate stop wiring.

Figure 7.12 illustrates wiring for a maintained 2-wire and for a momentary 3-wire Start / Stop control.

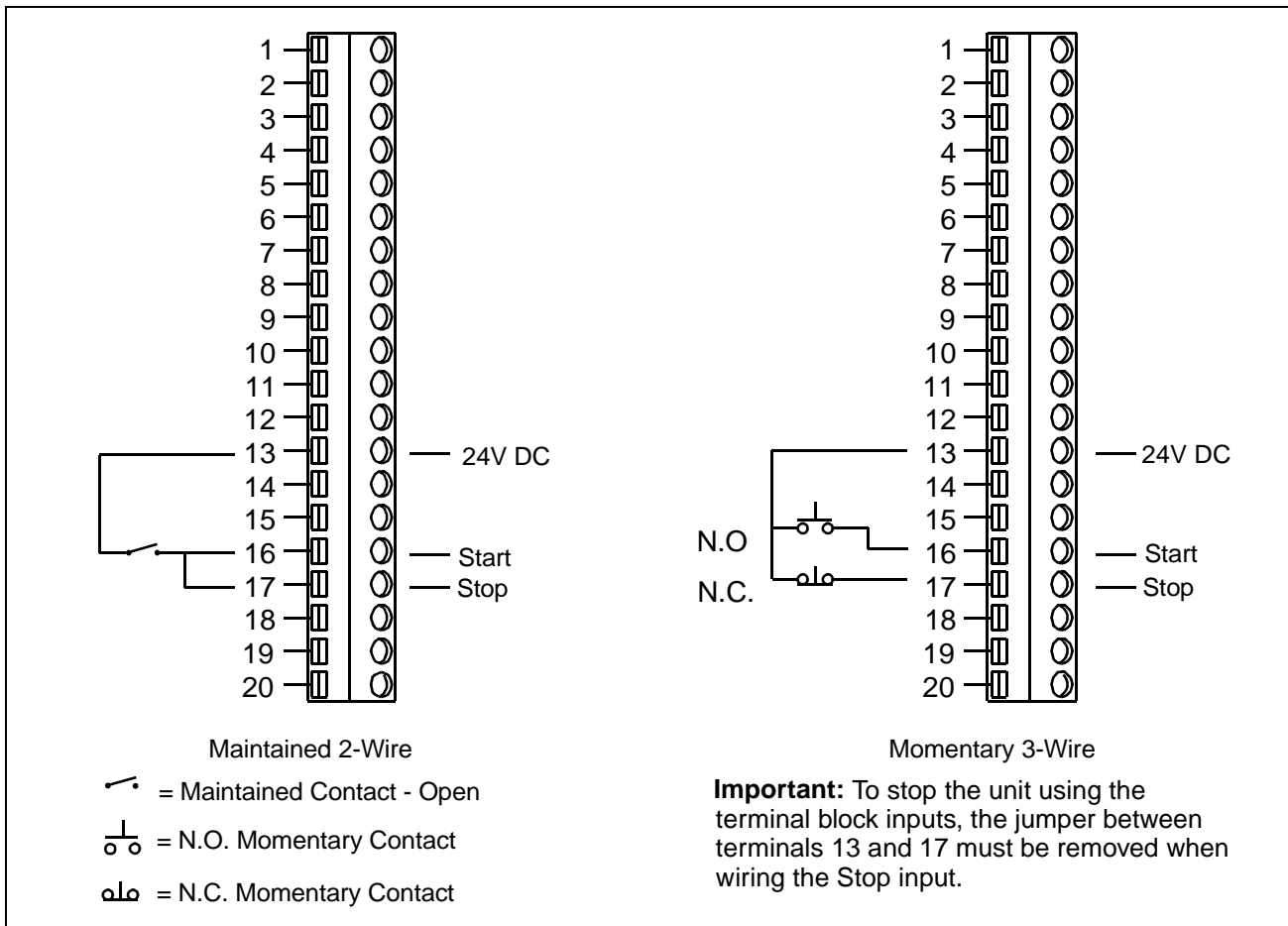

Figure 7.12 – Start / Stop Control Wiring

7.7 Wiring Forward / Reverse Control

Important: This applies only to standard units and local operator control units set up for terminal block control (setup slide switch position 9 = ON, see section 8.3.9).

The Forward / Reverse input (the connection between terminals 13 and 14) defines the requested direction of motor rotation. If the input is open, the requested direction is forward. Switching the Forward / Reverse input causes the motor to ramp to rest and then accelerate in the opposite direction. Note that the VSM500 unit is shipped with the forward direction defined as CCW shaft rotation as viewed from the motor shaft end.

Figure 7.13 shows the Forward / Reverse control wiring for the VSM500 unit. If you disable (lock out) reverse using the setup slide switch, do not wire to this input because the drive ignores any transition on this input. Refer to the setup slide switch description in chapter 8.

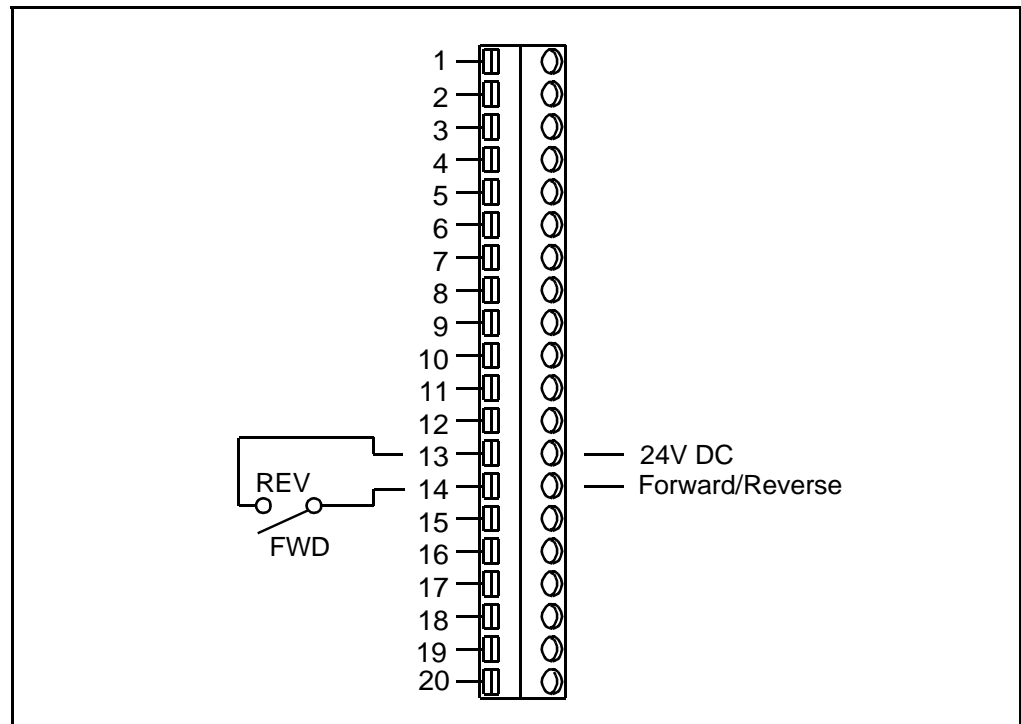

Figure 7.13 – Forward / Reverse Control Wiring

7.8 Wiring Reset Control

Important: This applies only to standard units and local operator control units set up for terminal block control (setup slide switch position 9 = ON, see section 8.3.9).

An open-to-closed transition at the Reset input (control terminal 15) clears a fault once the appropriate corrective action has been taken. After clearing the fault, you must reassert the Start command in order to restart the unit.

Wire a normally-open (N.O.) pushbutton between control terminals 15 and 13 as shown in figure 7.14. Refer to chapter 11, Diagnostics and Troubleshooting, for more information on faults.

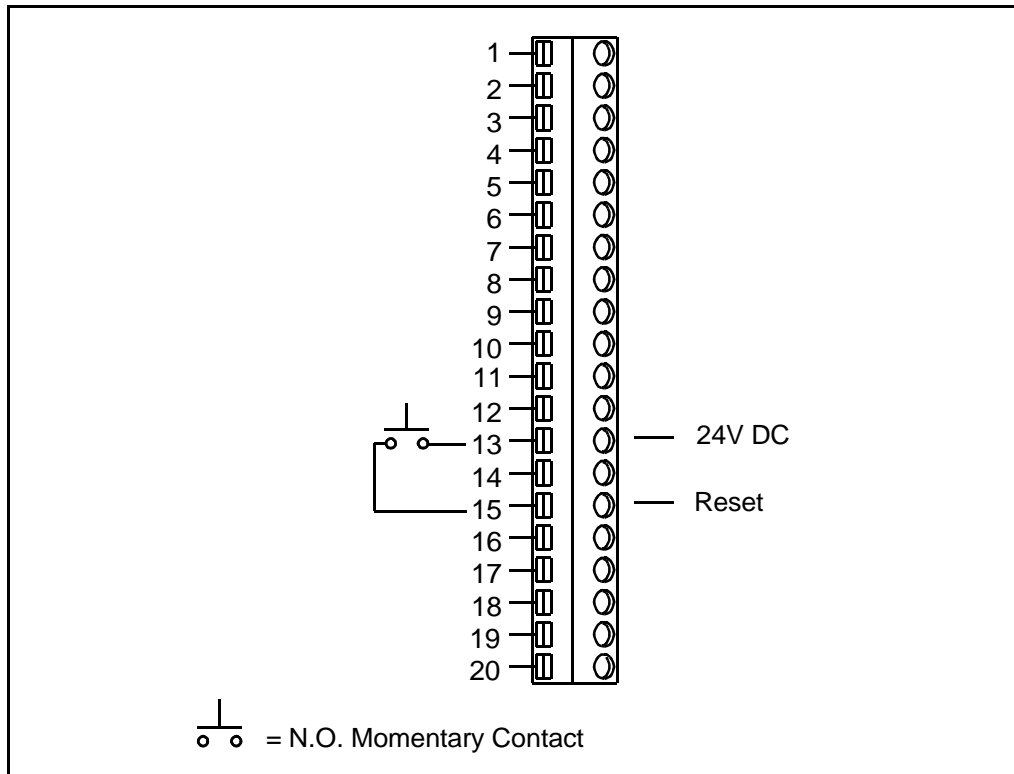

Figure 7.14 – Reset Control Wiring

Step 8 - Verify the Setup and Adjust Switches if Required

The VSM500 unit is set up using two rotary switches and a 10-position slide switch mounted on the printed circuit board as shown in figure 8.1. Figure 8.1 shows the setting selections and the factory defaults. **Normally, no adjustments will be needed to the factory settings.**

If your application requires adjustment to these settings, refer to the following sections in this chapter. If no adjustment is needed, go to chapter 9 to complete the installation procedure.



ATTENTION: Only qualified personnel familiar with the construction and operation of this equipment and the hazards involved should install, adjust, operate, and/or service this equipment. Read and understand this instruction manual in its entirety before proceeding. Failure to observe this precaution could result in severe bodily injury or loss of life.

ATTENTION: All adjustments to these components should be made with power removed. Failure to observe this precaution could result in severe bodily injury or loss of life.

ATTENTION: After disconnecting input power wait five minutes and check with a voltmeter to insure that DC bus capacitors are discharged. The voltmeter should read zero volts. Failure to observe this precaution could result in severe bodily injury or loss of life.

ATTENTION: The cover screws must be securely tightened in order to properly ground the cover. Verify that all four cover screws are tight before applying power to the unit. Failure to observe this precaution could result in severe bodily injury or loss of life.

Review all setup instructions thoroughly before making any adjustments or applying power to the unit.

After changing the setup, go to chapter 9 to complete the installation.

Before making any adjustments to the unit, be sure to take the following precautions:

- Step 1. Turn off, lockout, and tag AC input power to the unit.
- Step 2. Wait five minutes. Then remove the cover and use a voltmeter to verify that the DC bus capacitors are discharged. The voltmeter should read zero volts. Refer to figure 5.2 for the DC bus test points.

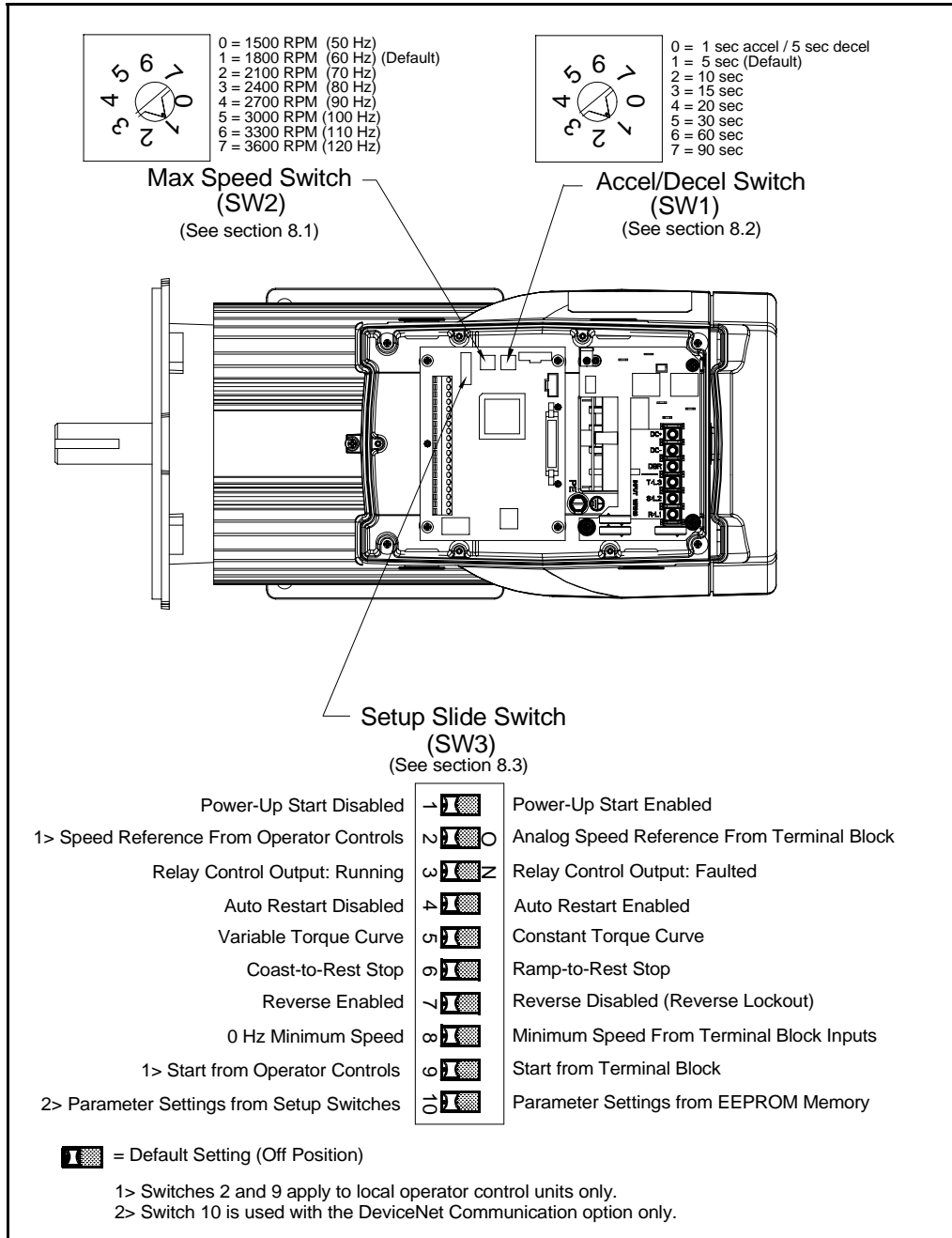

Figure 8.1 – Factory Settings for the Setup Rotary Switches and Slide Switch

8.1 Adjusting the Maximum Speed



ATTENTION: The user is responsible for ensuring that driven machinery and all drive-train mechanisms are capable of safe operation at maximum speed. Failure to observe this precaution could result in severe bodily injury or loss of life.

The maximum speed rotary switch limits the speed reference to the unit. Regardless of what speed reference is supplied, the unit will not command a speed greater than the value selected by this rotary switch.

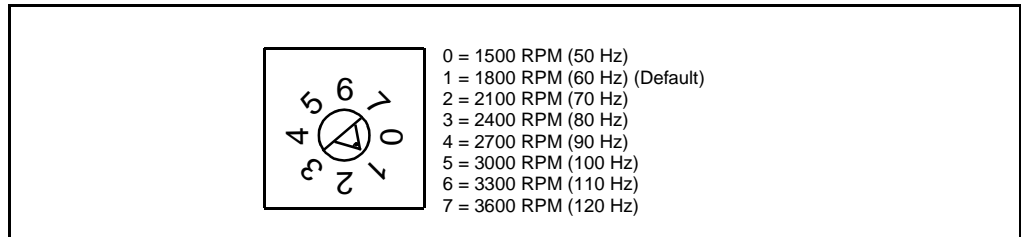

Figure 8.2 – Maximum Speed Rotary Switch

Range: 1500 RPM (50 Hz) to 3600 RPM (120 Hz)

Default: 1800 RPM (60 Hz)

To set the maximum speed:

Step 1. To **increase** the maximum speed, turn the maximum speed rotary switch to a higher position number.

-or-



To **decrease** the maximum speed, turn the maximum speed rotary switch to a lower position number.

Step 2. Connect the display board ribbon cable and replace the cover. Verify that all four cover screws are in place and tightened.

Step 3. Apply AC input power.

Step 4. Set the operator's speed reference signal to maximum.

Standard units: Use the speed potentiometer or other user-supplied external speed reference device.

Local operator control units: Use the  key to increase the speed reference and the  key to decrease the speed reference.

Step 5. Use a handheld tachometer to monitor motor speed.

Step 6. Repeat the adjustment procedure until the desired maximum speed is obtained. Note that changes to the maximum speed setting are recognized only while the drive is stopped.

Important: If speed is erratic or not as expected, verify that only one of the speed reference inputs (0 to 10 VDC or 4 to 20 mA) has been wired.

8.2 Adjusting the Acceleration / Deceleration Time

The acceleration / deceleration time is the amount of time it takes the motor to ramp from stop to the maximum speed setting of the unit. This is also the amount of time it takes the motor to ramp from the maximum speed setting to stop.

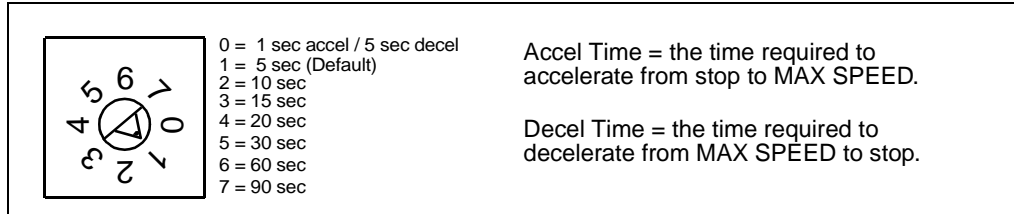
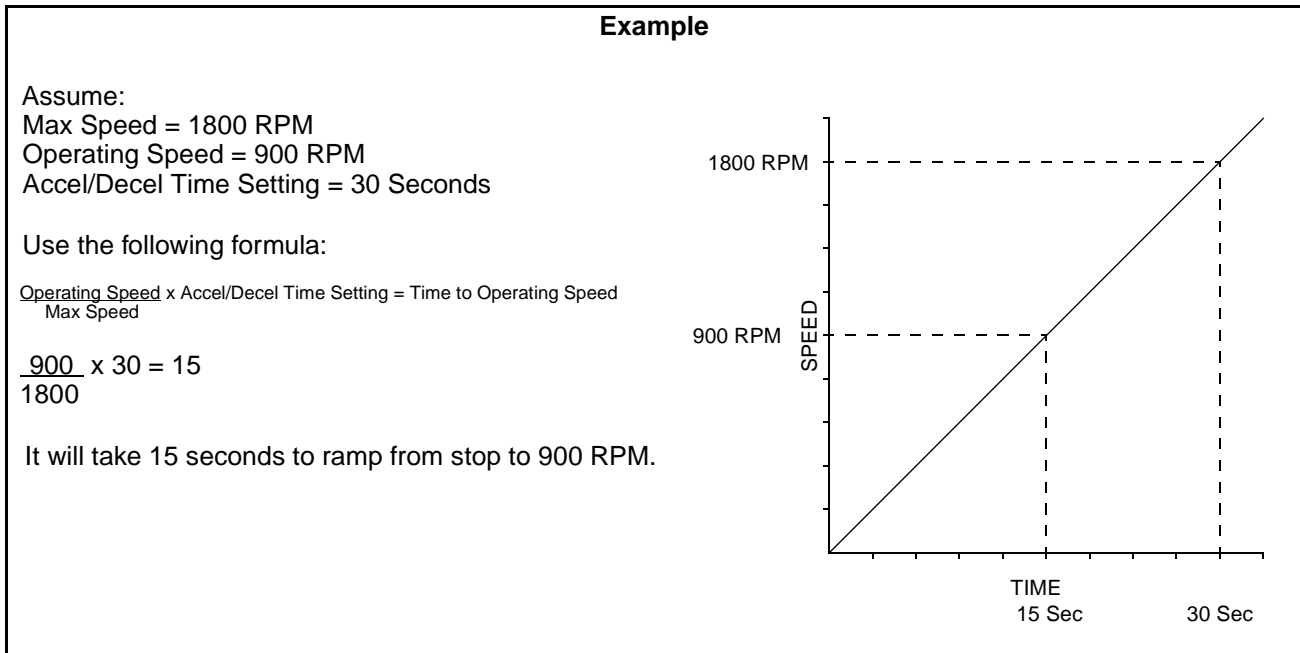

Figure 8.3 – Acceleration / Deceleration Rotary Switch

Range: 1, 5, 10, 15, 20, 30, 60, 90 seconds

Default: 5 seconds

Note that if the operator speed reference setting is less than the maximum speed value, the acceleration / deceleration ramp time is proportionately less than the acceleration / deceleration setting.



To adjust the acceleration / deceleration time:

Step 1. To **increase** the acceleration / deceleration time, turn the accel / decel rotary switch to a higher position number.

-or-

To **decrease** the acceleration / deceleration time, turn the accel / decel rotary switch to a lower position number.

Step 2. Connect the display board ribbon cable and replace the cover. Verify that all four cover screws are in place and tightened.

Step 3. Apply AC input power.

Step 4. Set the desired operating speed.

Standard units: Use the speed potentiometer or other user-supplied external speed reference device.

Local operator control units: Use the ▲ key to increase the speed reference and the ▼ key to decrease the speed reference.

Step 5. Repeat the adjustment procedure until the desired acceleration / deceleration time is obtained. Note that changes to the acceleration / deceleration time are recognized only while the drive is stopped.

Important: If speed is erratic or not as expected, verify that only one of the speed reference inputs (0 to 10 VDC or 4 to mA) has been wired.

8.3 Modifying the Setup Using the Setup Slide Switch

The switches in the 10-position setup slide switch define the characteristics of the VSM500 unit as shown in figure 8.4. The switches are preset at the factory to suit a wide range of applications and normally do not need to be changed. The following sections describe how to modify the setup to suit your specific application, if required.

Important: Changes to the slide switch settings are recognized only while the drive is stopped.

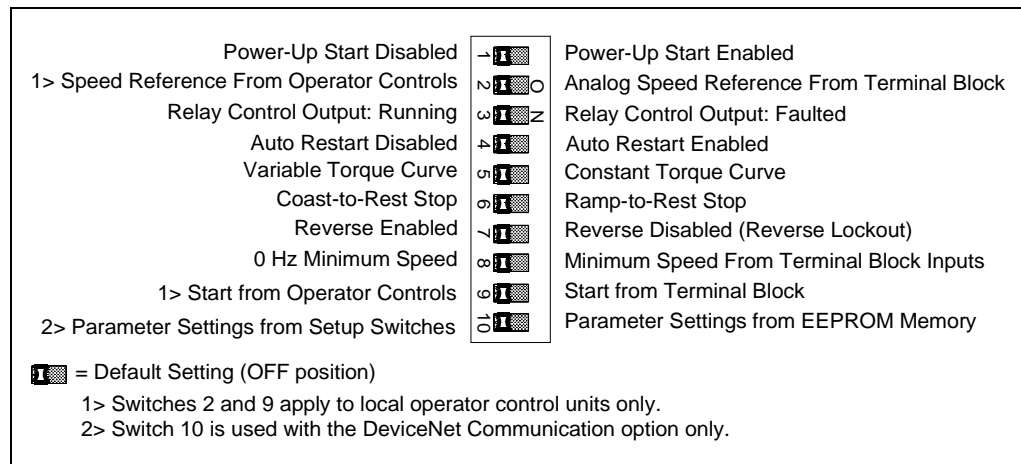

Figure 8.4 – Setup Slide Switch Selections

8.3.1 Power-Up Start (Position 1)



ATTENTION: Enabling this feature causes output power to be applied to the motor section automatically at drive power up. When this feature is enabled, the user must ensure that automatic start up of the driven equipment will not cause injury to the operating personnel or damage to the driven equipment. In addition, the user is responsible for providing suitable audible or visual alarms or other devices to indicate that this function is enabled and the drive may start at any moment. Failure to observe this precaution could result in severe bodily injury or loss of life.

Important: If AC power is lost, the drive will restart without command when power is returned. Under these circumstances, it is the responsibility of the user to ensure that a dangerous condition does not exist when lost AC power returns.

The switch at position 1 enables or disables the power-up start function. When this function is enabled, output power is applied to the motor section automatically at power up if all power-up start permissive conditions are met. These conditions are:

- No faults are active.
- The terminal strip function loss input is closed.
- **For terminal block control:** In addition to the start permissive conditions listed above, the terminal strip Start and Stop inputs must be closed.
- **For local operator control:** The unit will simulate a start signal edge; you do not have to press the green  key.



Settings (Position 1):

OFF position = Power-Up Start Disabled (Default)

ON position = Power-Up Start Enabled

8.3.2 Speed Reference Select (Position 2)

Important: This applies only to local operator control units.

The switch at position 2 is used to select whether the unit gets its speed reference from the operator controls or from the analog input terminals. If this switch is set to the OFF position, the speed reference will come from the operator controls. If this switch is set to the ON position, the speed reference will come from the analog input terminals, and the  and  keys are not functional.

Settings (Position 2):

OFF position = Speed Reference from Operator Controls (Default)

ON position = Speed Reference from Analog Input Terminals

8.3.3 Relay Control Output - Running or Faulted (Position 3)

The switch at position 3 specifies the type of status indication provided by the normally open (N.O.) relay control output (control terminals 19 and 20). See section 7.3 for a description of control terminals 19 and 20. The relay can be used to indicate that the unit is running (power is applied to the motor section) or has faulted (an active drive fault exists).

Switch 3 Position	State of Unit	Relay Control Output Status
OFF (Unit running indication selected)	Running	Closed
	Stopped	Open
ON (Unit faulted indication selected)	No Faults	Closed
	Active Fault	Open

Settings (Position 3):

OFF position = Unit Running Indication (Default)
 ON position = Unit Faulted Indication

8.3.4 Auto Restart (Position 4)



ATTENTION: Enabling this feature causes the unit to restart automatically after auto-restartable faults (see table 8.1) have shut down the unit. When this feature is enabled, the user must ensure that automatic restart of the driven equipment will not cause injury to operating personnel or damage to the driven equipment. Failure to observe this precaution could result in severe bodily injury or loss of life.

The switch at position 4 enables or disables the auto-restart function. If the auto-restart function is enabled, the unit shuts down as usual upon the detection of a fault, waits five seconds, and attempts to start automatically. If the fault reoccurs, the drive section again waits five seconds before trying to start, up to a maximum of four attempts within a five minute period. If the drive section fails all these attempts, it remains in the faulted state and displays the fault it is attempting to clear.

While the unit is counting down the five-second restart period, the display flashes the following pattern to warn of the impending automatic restart of the drive:

Ar05 Ar04 Ar03 Ar02 Ar01

If the Reset input is asserted (or the **RESET** key is pressed) during the countdown, the auto-restart process is canceled. Table 8.1 lists the auto-restartable faults.

Table 8.1 – Auto Restartable Faults

Fault Code	Description
<i>F.DC</i>	Overcurrent
<i>F.DL</i>	Overload
<i>F.HU</i>	High bus voltage
<i>F.LU</i>	Low bus voltage
<i>F.OH</i>	Overtemperature

Settings (Position 4):

OFF position = Auto-Restart Disabled (Default)
 ON position = Auto-Restart Enabled

8.3.5 Torque Curve (Position 5)

The switch at position 5 selects either a variable torque curve or a constant torque curve. The variable torque selection provides a squared V/Hz curve and 110% electronic thermal overload and 110% current limit for one minute. The constant torque selection provides a linear V/Hz curve and 150% electronic thermal overload and 150% current limit for one minute.

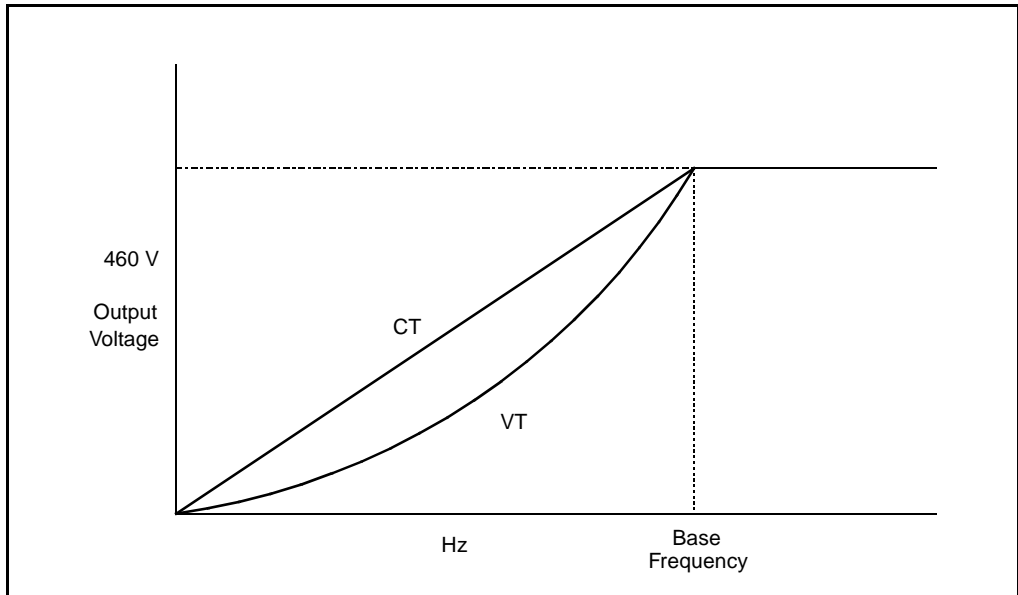



Figure 8.5 – Torque Curves

Settings (Position 5):

OFF position = Variable Torque Curve (Default)
 ON position = Constant Torque Curve

8.3.6 Stop Type (Position 6)

The switch at position 6 selects how the motor will stop when the Stop input is asserted (or the red  key is pressed). A coast-to-rest stop turns off the transistor power device drivers. A ramp-to-rest stop continues to switch the transistor power device drivers until the output frequency equals 0 Hz (decelerating the motor at a rate based on the accel / decel switch setting), and then turns off the power device drivers.

Settings (Position 6):

OFF position = Coast-to-Rest (Default)
ON position = Ramp-to-Rest

8.3.7 Reverse Disable (Position 7)

The switch at position 7 enables or disables reverse rotation of the motor. It is factory-set to enable a forward-to-reverse change of motor direction. If this switch is in the ON position, the reverse direction is disabled (locked out). In other words, the motor can run in the forward direction only.

Settings (Position 7):

OFF position = Reverse Enabled (Forward/reverse change allowed; default)
ON position = Reverse Disabled (Reverse direction prohibited)

8.3.8 Minimum Speed Select (Position 8)



ATTENTION: The VSM500 unit can operate at and maintain zero speed. The user is responsible for assuring safe conditions for operating personnel by providing suitable guards, audible or visual alarms, or other devices to indicate that the drive is operating or may operate at or near zero speed. Failure to observe this precaution could result in severe bodily injury or loss of life.

The switch at position 8 is used to select whether the minimum speed will be 0 RPM (0 Hz) or will be determined by the preset inputs (terminals 8, 9, and 10 on the control terminal block).

Important: Slide switch position 8 defines whether terminals 8, 9, and 10 are used as presets (default) or to define the unit's minimum speed (user option). If you select the ON position (Minimum Speed from the Control Signal Terminal Block), you cannot use the speed reference presets. See section 7.5.1 for information about the preset speed inputs.

Settings (Position 8):

OFF position = 0 RPM (0 Hz) Minimum Speed (Default)
ON position = Minimum Speed from the Control Terminal Block

When the switch in position 8 is ON, the minimum speed will be determined as shown in the following table:

Control Terminal Block			Slide Switch Position 8 = ON
Terminal 8 Status	Terminal 9 Status	Terminal 10 Status	Minimum Speed Setting
Open	Open	Open	0 RPM (0 Hz)
Open	Open	Closed	150 RPM (5 Hz)
Open	Closed	Open	300 RPM (10 Hz)
Open	Closed	Closed	600 RPM (20 Hz)
Closed	Open	Open	900 RPM (30 Hz)
Closed	Open	Closed	1200 RPM (40 Hz)
Closed	Closed	Open	1500 RPM (50 Hz)
Closed	Closed	Closed	1800 RPM (60 Hz)

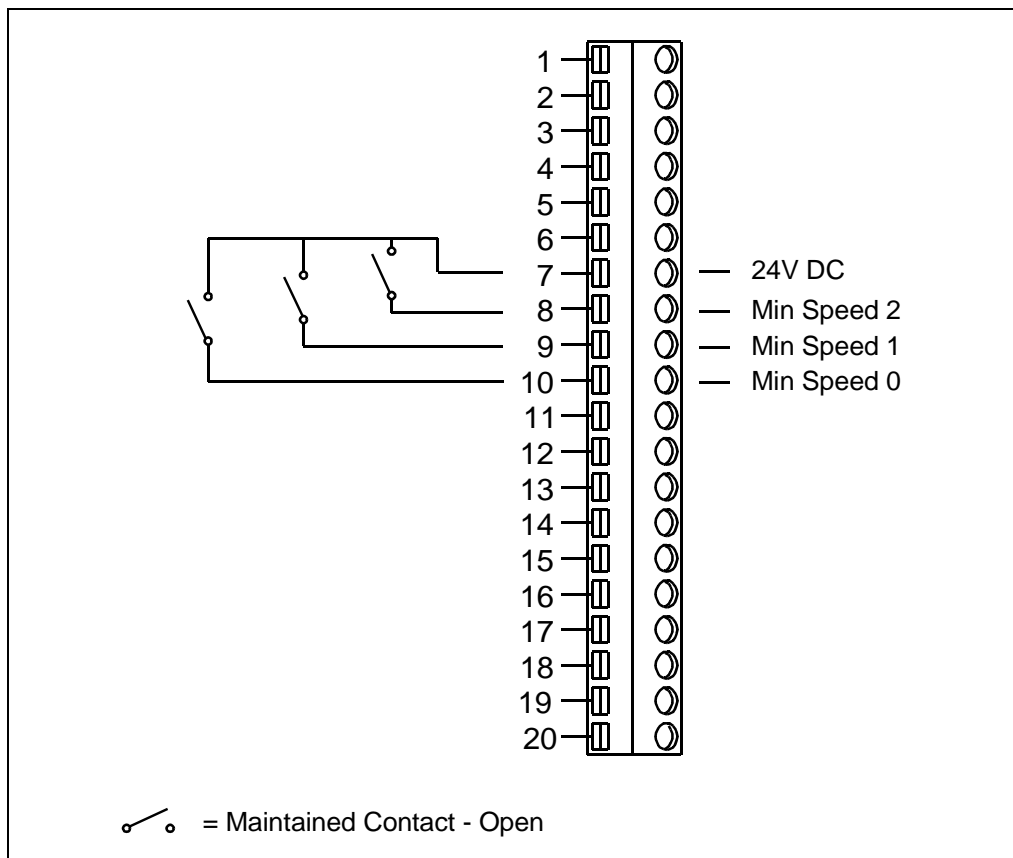



Figure 8.6 – Wiring Minimum Speed

8.3.9 Start Mode Select (Position 9)

Important: This switch applies only to the local operator control units.

The switch at position 9 is used to select whether the unit is controlled from the operator controls or from the terminal block.

Note that if the unit is set up for terminal block control (Start Mode Select = ON), the  and **RESET** keys remains active.

Settings (Position 9)

OFF position = Control from the Operator Controls (default)

ON position = Control from the Terminal Block

Important: The drive will not start when power is applied after changing this setting. The start command must be reasserted in order to start the drive.

8.3.10 Parameter Mode for DeviceNet Option (Position 10)

Important: This switch applies only to the DeviceNet Communication option.

The switch at position 10 is used to select whether the unit gets its parameter settings from the rotary switches and setup slide switch (SW1, SW2, and SW3) or from the EEPROM memory. Refer to the DeviceNet Option board instruction manual (D2-3463) for information on installing and configuring the DeviceNet Option board.

This switch setting is read when power is applied.

Settings (Position 10)

OFF position = Parameter Settings from the Rotary Switches and Setup Slide Switches (SW1, SW2, and SW3).

ON position = Parameter Settings from the EEPROM Memory.

Step 9 - Check the Installation



ATTENTION: Only qualified electrical personnel, familiar with the construction and operation of this equipment and the hazards involved, should install, adjust, operate, and/or service this equipment. Read and understand this manual in its entirety before proceeding. Failure to observe these precautions could result in severe bodily injury or loss of life.

To ensure safe operation, check the installation with the power off before operating the unit. When power is first applied, the direction of rotation, operator speed reference, and operation under load should be tested.

9.1 Checking the Installation with the Power Off



ATTENTION: After disconnecting input power wait five minutes and check with a voltmeter to insure that DC bus capacitors are discharged. The voltmeter should read zero volts. Failure to observe these precautions could result in severe bodily injury or loss of life.

Perform the following checks of the unit installation with the power off:

- Step 1. Turn off, lockout, and tag AC input power to the unit.
- Step 2. If an input disconnect is installed, make sure it is in the OFF position.
- Step 3. Wait five minutes after disconnecting power and verify that the DC bus has discharged to zero volts. See figure 5.2 for the test points used to measure DC bus voltage.
- Step 4. Check that any interlocks installed around the driven machine are operational.
- Step 5. Check that there is adequate clearance around the unit. Refer to figure 2.2.
- Step 6. Check that the wiring to the control signal terminal strip and to the power terminals is correct (figures 5.2 and 7.1 through 7.14).
- Step 7. Check the setup slide switch and the rotary switches are set correctly.
- Step 8. Check that user-supplied branch circuit protection is properly installed and correctly rated.
- Step 9. Check that incoming AC power is correctly rated.
- Step 10. Check that the rating of the transformer (if used) matches the unit requirements and that the transformer is connected for the proper voltage.
- Step 11. Check that a properly sized ground wire is installed and that a suitable earth ground is used. Verify that all ground leads are run unbroken.

9.2 Checking the Direction of Motor Rotation

The VSM500 unit is shipped with the forward direction defined as counterclockwise (CCW) shaft rotation as viewed from the motor shaft end. If this is appropriate for your application, go to section 9.3, Attaching the Cover.

If this is not appropriate for your application, do one of the following:

- Change the direction by using the Forward / Reverse input to select the appropriate direction.
- or-
- Change the definition of forward and reverse by swapping the U/T1 and W/T3 connectors as shown in figure 9.1.

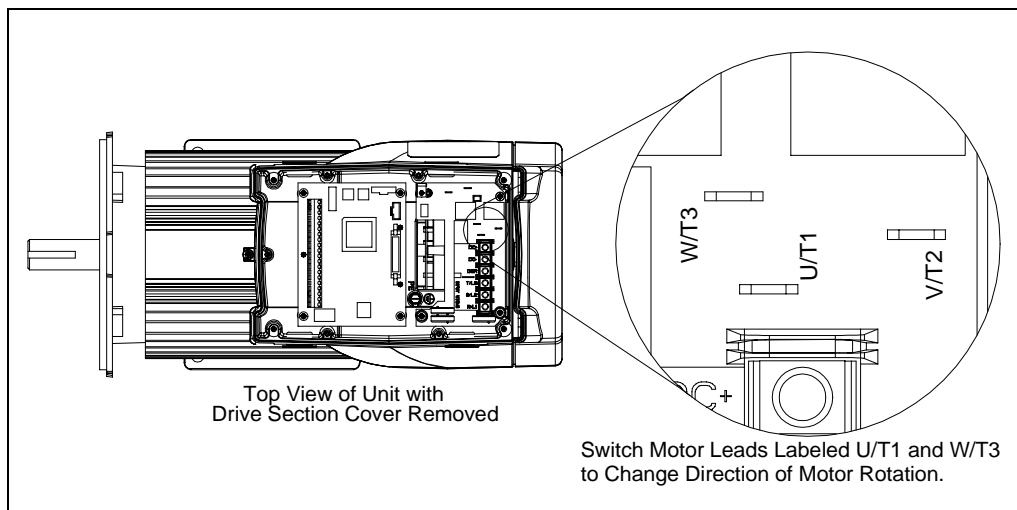

Figure 9.1 – Changing the Definition of Forward and Reverse

9.3 Attaching the Cover



ATTENTION: The cover screws must be securely tightened in order to properly ground the cover. Verify that all four cover screws are tight before applying power to the unit. Failure to observe this precaution could result in severe bodily injury or loss of life.

The cover can be rotated 180° to allow the display and local operator controls to be in the correct orientation regardless of the mounting position. Before attaching the cover, determine the proper cover orientation. If the cover must be rotated, follow the procedure in section 9.3.1.

Before reattaching the cover, be sure the display board ribbon cable is securely connected, then position the cover and tighten the screws. The tightening torque limit for the cover screws is 1.3 to 1.7 Nm (11 to 15 in-lb). Verify that all four screws are securely tightened before applying power.

9.3.1 Rotating the Cover

Before rotating the cover, take the following precautions:

- Step 1. Turn off, lockout, and tag AC input power to the drive.
- Step 2. Remove the cover by loosening the four cover screws. Note that the display board ribbon cable is designed to disconnect when the cover is removed.
- Step 3. Wait five minutes after disconnecting power and verify that DC bus voltage is zero. See figure 5.1 for the location of the DC bus test points.

Refer to figure 9.2 and use the following procedure to rotate the cover:

- Step 1. Remove the display board ribbon cable from the display board. You will need to insert a small screwdriver into the cable latch to release it from the board.
- Step 2. Insert the display board ribbon cable into the opposite side of the display board. Push the cable in until it clicks. Verify the connection by lightly tugging on the cable.
- Step 3. Rotate the cover.
- Step 4. Connect the display board ribbon cable together.
- Step 5. Position the cover and tighten the four cover screws. The tightening torque limit for the cover screws is 1.3 to 1.7 Nm (11 to 15 in-lb). Verify that all four screws are securely tightened before applying power.

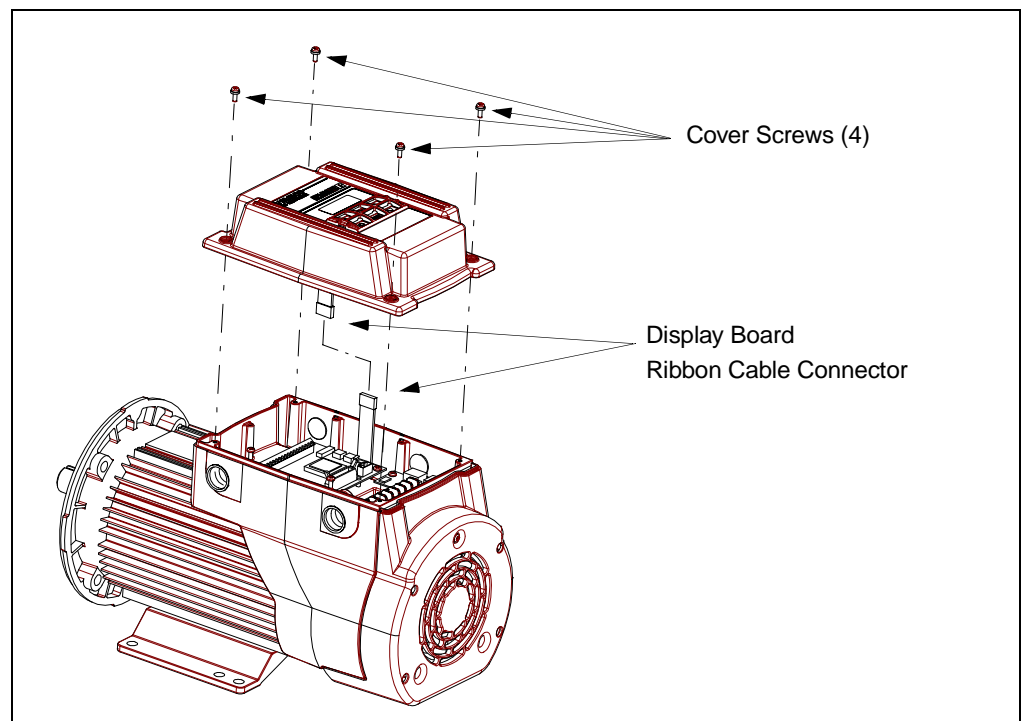

Figure 9.2 – Rotating the Cover

9.4 Checking the Speed Reference



ATTENTION: The following procedures require rotating parts and/or electrical circuits to be exposed. Stay clear if the unit must be running. Disconnect, lockout, and tag the power source if contact must be made. Failure to observe these precautions could result in severe bodily injury or loss of life.

Use the following procedure to check the speed reference:

Step 1. Uncouple the driven equipment from the motor section, if possible.

Step 2. Turn power on to the unit.

Step 3. Set the operator speed reference signal to zero. Note that when the unit is powered up the first time, it uses the factory-set minimum speed setting as the speed reference.

For terminal block speed reference: Use the speed potentiometer or other user-supplied external speed reference device.

For local operator control speed reference: Use the  key to decrease the speed reference.

Step 4. Press the user-installed Start button (section 7.6) or the green  key on local operator control units.

Step 5. Vary the speed reference while running the motor unloaded across the speed range. Use a handheld tachometer to check the speed.

Step 6. If the motor operates satisfactorily, proceed to step 8.
If the motor does not operate satisfactorily, continue with step 7.

Step 7. If the motor does not operate satisfactorily:

- a. Check that the speed reference is wired correctly. See section 7.5, Wiring the Speed Reference.
- b. If the speed reference is correct, and the motor does not operate satisfactorily, refer to chapter 8, Verify the Setup and Adjust the Switches if Required.



Step 8. If the motor operates satisfactorily:



- a. Press the user-installed Stop button (section 7.6) on standard units or the red  key on the local operator control units.
- b. Remove power from the unit.
- c. Couple the driven equipment to the motor section.

Step 10 - Set the Operating Speed

Before starting the unit, set the operating speed as follows:

For standard units: Use the speed potentiometer or other user-supplied external speed reference device.

For local operator control units: As shipped from the factory, the local operator control unit receives its speed reference from the keypad. Use the  key to increase the speed reference and the  key to decrease the speed reference.

To use the analog input terminals for the speed reference, setup switch 2 (Speed Reference Select) must be in the ON position. In this case, the   keys are not used. Refer to section 8.3.2 for more information.

At subsequent power ups, the unit will use the last speed reference setting selected before power was removed.

Important: If speed is erratic or not as expected, verify that only one of the speed reference inputs (0 to 10 VDC or 4 to 20 mA) has been wired.

Diagnostics and Troubleshooting



ATTENTION: Only qualified personnel familiar with the construction and operation of this equipment and the hazards involved should install, adjust, operate, and/or service this equipment. Read and understand this instruction manual in its entirety before proceeding. Failure to observe this precaution could result in severe bodily injury or loss of life.

ATTENTION: After disconnecting input power, wait five minutes and check with a voltmeter to insure that DC bus capacitors are discharged. The voltmeter should read zero volts. Failure to observe these precautions could result in severe bodily injury or loss of life.

ATTENTION: If a megohmmeter (megger) is used, make certain that all leads are disconnected between the motor and the drive. This will prevent damage to electronic circuitry due to high voltage generated by the megger. Use three wires to megger to ground. Failure to observe this precaution could result in damage to, or destruction of, the equipment.

Use the following flowchart to troubleshoot the unit.

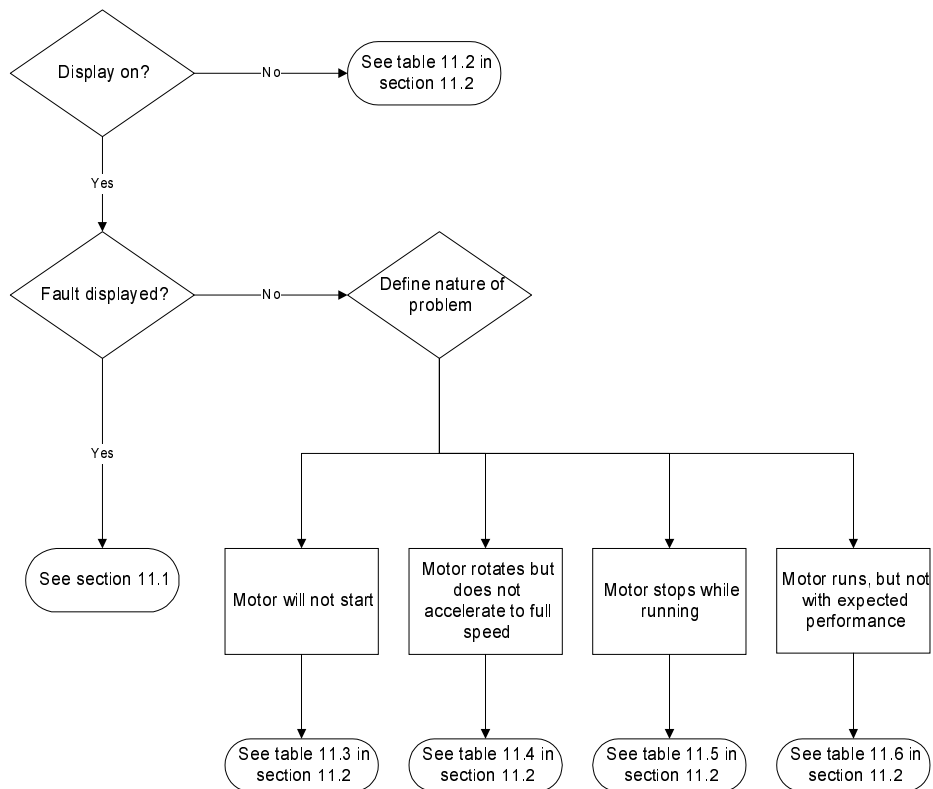

Observe the following precautions when troubleshooting the unit:

- Stop the unit using either the Stop input or Function Loss input.
- Disconnect, tag, and lockout AC power before working on the unit.
- Verify that there is no voltage present at AC input terminals R/L1, S/L2, and T/L3. Refer to figure 5.2 for the location of the terminals.
- Wait five minutes and verify that the DC bus has discharged to zero volts. See figure 5.2 for the location of the DC bus test points.

11.1 Fault Codes and Corrective Actions

The following table describes normal operational faults that may be corrected by the user. For standard units, the corrective action assumes that a Reset pushbutton is wired between control terminals 15 and 13, as described in section 7.8.

If a fault occurs, do the following:

Step 1. Try to clear the fault first by pressing the Reset pushbutton (or **RESET** key on local operator control units). If the fault reoccurs, continue with step 2.

Step 2. Refer to table 11.1 to identify the fault code and the possible causes.

Important: Contact Reliance if the displayed fault code is not in table 11.1.

Step 3. Perform the corrective action(s).

Step 4. Clear the fault by pressing the Reset pushbutton (or **RESET** key).

Table 11.1 – Fault Codes and Corrective Actions

Fault Code	Fault Description	Fault Cause	Corrective Action
<i>F.CL</i>	Communication Loss	Communication cable between the DeviceNet option board and the drive disconnected or opened.	Turn off power to the unit. Verify the cable connection between the Regulator board and the DeviceNet option board. Turn power on to the unit.
<i>F.dCH</i>	Parameter Checksum	Contents of the EEPROM is corrupted.	Reset parameters to default values and cycle power.
<i>F.dcn</i> or <i>F.ddP</i>	Keypad Cable Disconnected	Keypad cable disconnected while unit under power.	Turn off power to the unit. Verify the keypad cable connection. Turn power on to the unit.
<i>F.dnX</i>	DeviceNet Communication Fault where X = E, F, L, P, or U.		Refer to the VSM500 DeviceNet Option Board manual, D2-3463.
<i>F.drc</i>	Keypad Cable Connected	Keypad cable connected while unit under power.	Turn off power to the unit. Verify the keypad cable connection. Turn power on to the unit.

Table 11.1 – Fault Codes and Corrective Actions (Continued)

Fault Code	Fault Description	Fault Cause	Corrective Action
<i>F.dSF</i>	Keypad Redundant Start	Keypad hardware malfunction.	Turn power off to the unit. Verify the keypad cable connection. Turn power on to the unit.
<i>F.FL</i>	Function Loss	Open connection on Function Loss control terminal block inputs (terminals 7 and 11).	Check and restore the Function Loss connection on the control terminal block (see section 7.1). Check the external sensors wired into the Function Loss string.
<i>F.HU</i>	High Bus Voltage	High input line. Deceleration time too fast. Overhauling load.	Check input line to verify voltage is within operating specifications. Increase deceleration time using the accel/decel rotary switch (see section 8.2).
<i>F.Id</i>	EEPROM Drive ID	Contents of the EEPROM is corrupted.	Reset parameters to default values and cycle power. If fault persists, replace unit.
<i>F.LU</i>	Low Bus Voltage	Low input line Temporary loss of input line.	Check input line to verify voltage is within operating specifications.
<i>F.OC</i>	Overcurrent (Current exceeded 200% of rated current.)	Shaft rotation blocked. Excessive driven load. Input power is not correctly wired to the unit. Motor section ground fault.	Check for obstructions to shaft rotation. Reduce excessive load. Increase accel / decel time using the accel/decel rotary switch (see section 8.2). Verify input wiring is correctly connected (see section 5.0). Ohm out motor section to check for ground fault. Replace motor section if a ground fault is detected.
<i>F.OH</i>	Unit Overtemperature	Operating environment is too hot. Blower is blocked or not operating. Excessive driven load.	Check the application site and verify the ambient temperature is within the operating specification. Check for blower obstruction. Replace blower if required. Reduce load or make sure unit matches the application requirement.

Table 11.1 – Fault Codes and Corrective Actions (Continued)

Fault Code	Fault Description	Fault Cause	Corrective Action
<i>F. OL</i>	Electronic Thermal Overload The electronic thermal overload will trip when the current to the motor has exceeded either 110% (variable torque V/Hz curve selected) or 150% (constant torque V/Hz curve selected) of the motor rated current for 60 seconds.	Excessive current to the motor for an extended time due to excessive load or short circuit.	Check for obstructions to shaft rotation. Reduce the driven load. Verify input wiring is correctly connected (see section 5.0). Check for blower obstruction. Replace blower if required.
<i>F. SF</i>	TB Redundant Start	Regulator board malfunction.	Turn off power to unit. Verify the keypad cable connection. Turn power on to the unit.
=NNN	Internal Fault (NNN = a number from 0 to 999) The display flashes the fault code on and off at 1/2 second intervals to indicate an internal fault.	Regulator board failure.	Replace Regulator board. Internal faults cannot be reset.

11.2 Troubleshooting Tables

Use the following tables to troubleshoot the unit. If you cannot resolve the problem using these tables, systematically replace the drive section and the motor section one at a time with a corresponding drive section or motor known to be operating correctly. If the problem is not corrected, contact Reliance.

Table 11.2 – Display Not On

Possible Cause	Corrective Action
Unit is not receiving input power.	Check input power wiring and connections (see section 5.0). Check main power supply.
Display ribbon cable is not connected securely.	Open the cover and verify the cable connection by lightly tugging on the cable at each end. If the cable is disconnected, push the cable in until it clicks.
Display ribbon cable is damaged.	Replace ribbon cable.

Table 11.3 – Motor Will Not Start



Possible Cause	Corrective Action
Drive section has faulted.	See section 11.1.
Unit is not receiving input power.	Check input power wiring and connections (see section 5.0). Check main power supply.
Start input is not asserted.	Check terminal board wiring. Assert Start input on standard unit (see section 7.6) or press green  key on local operator control unit.
Function Loss input wiring is missing or incorrectly wired.	Check Function Loss wiring (see section 7.1).
Stop input is open.	Close Stop input.
Faults have not been cleared. Fault code is displayed.	Clear the faults by pressing the Reset pushbutton (wired between control terminals 13 and 15, see section 7.8) on standard units or pressing the  key on local operator control units.

Table 11.4 – Motor Rotates but Does Not Accelerate to Full Speed

Possible Cause	Corrective Action
Maximum speed is set too low.	Increase maximum speed by turning the maximum speed rotary switch to a higher position (see section 8.1).
Unit is receiving incorrect speed reference.	Verify speed reference wiring (see section 7.5).
Excessive load.	Reduce load; make sure the unit matches the application requirement.

Table 11.5 – Motor Stops While Running

Possible Cause	Corrective Action
Drive section has faulted.	See section 11.1.

Table 11.6 – Motor Runs, But Not with Expected Performance

Symptom	Corrective Action
Motor accelerates too slowly.	Check accel / decel switch setting (see section 8.2). Verify applied voltage. Verify input wiring. Reduce load.
Motor accelerates too quickly.	Check accel / decel switch setting (see section 8.2).
Motor acceleration / deceleration is not smooth.	Check the motor coupling to load.
Motor stops too slowly or too quickly.	Check Stop Type slide switch selection (see section 8.3.6). Check accel / decel switch setting (see section 8.2)
Blower does not operate.	Check wiring. Verify that blower can rotate freely. Verify that input voltage is correct. Replace blower.
High amps; %load indicates > 100%	Verify load is not excessive. Verify input line voltages.
Runs hot	Clean unit. Check input power connections (see section 5.0). Check input power phases. Check input fuses. Check power supply. Check blower.
Noisy	Check bearings; replace if necessary. Check unit mounting (alignment, etc.).
Runs in wrong direction.	Refer to section 9.3 (Checking the Direction of Motor Rotation).
Erratic speed	Verify ground connection (see section 5.1). Verify that only one of the speed reference inputs (0-10 VDC or 0-20 mA) has been wired (see section 7.5.3). Verify that there is no noise on the analog reference signal. Check the speed reference setting and wiring.

11.3 Replacement Parts

Tables 11.7 through 11.9 list the replacement parts for the VSM500 unit. Table 11.10 lists replacement bearings for the motor section.

Table 11.7 – Replacement Parts for 460 VAC Units

Replacement Part	1 HP Unit	2 HP Unit	3 HP Unit	5 HP Unit
Drive Section - 460 VAC, 3-Phase, with Display	10XS4000	21XS4000	32XS4000	52XS4000
Drive Section - 460 VAC, 3-Phase, with Operator Controls	10XW4000	21XW4000	32XW4000	52XW4000
Motor Section - 460 VAC, 3-Phase, NEMA 56	J56Z5411	-	-	-
Motor Section - 460 VAC, 3-Phase, NEMA 140	J14Z5411	J14Z5421	-	-
Motor Section - 460 VAC, 3-Phase, NEMA 180	-	-	J18Z5431	J18Z5451
Blower	164454	164454	22650-002-01	22650-002-01
Blower Cover	164408	164408	164409	164409
Cover with Display (includes display cable)	194431	194431	194431	194431
Cover with Display and Operator Controls (includes display cable)	194432	194432	194432	194432
Optional Short Cover with Display (includes display cable) ¹	195083	195083	195083	195083
Optional Short Cover with Display and Operator Controls (includes display cable) ¹	195084	195084	195084	195084
Regulator Board	194458	194458	194458	194458
Display Cable (Long)	184314	184314	184314	184314

¹The short cover cannot be used with the DeviceNet Communication option.

Table 11.8 – Replacement Parts for 230 VAC Units

Replacement Part	1 HP Unit	2 HP Unit
Drive Section - 230 VAC, 3-Phase with Display	10XS2000	21XS2000
Drive Section - 230 VAC, 3-Phase with Operator Controls	10XW2000	21XW2000
Drive Section - 230 VAC, 1-Phase with Display	10XS3000	21XS3000
Drive Section - 230 VAC, 1-Phase with Operator Controls	10XW3000	21XW3000
Motor Section - 230 VAC, 1- and 3-Phase NEMA 56	J56Z5211	-
Motor Section - 230 VAC, 1- and 3-Phase NEMA 140	J14Z5211	J14Z5221
Blower	164454	164454
Blower Cover	164408	164408
Cover with Display (includes display cable)	194431	194431
Cover with Display and Operator Controls (includes display cable)	194432	194432
Optional Short Cover with Display (includes display cable) ¹	195083	195083
Optional Short Cover with Display and Operator Control (includes display cable) ¹	195084	195084
Regulator Board	194458	194458
Display Cable (Long)	184314	184314

¹The short cover cannot be used with the DeviceNet Communication option.

Table 11.9 – Replacement Parts for 115 VAC Units

Replacement Part	1 HP Unit
Drive Section - 115 VAC, 1-Phase with Display	10XS1000
Drive Section - 115 VAC, 1-Phase with Operator Controls	10XW1000
Motor Section - 115 VAC, 1-Phase NEMA 56	J56Z5111
Motor Section - 115 VAC, 1-Phase NEMA 140	J14Z5111
Blower	164454
Blower Cover	164408
Cover with Display (includes display cable)	194431
Cover with Display and Operator Controls (includes display cable)	194432
Optional Short Cover with Display (includes display cable) ¹	195083
Optional Short Cover with Display and Operator Controls (includes display cable) ¹	195084
Regulator Board	194458
Display Cable (Long)	184314

¹The short cover cannot be used with the DeviceNet Communication option.

Table 11.10 – Replacement Bearings

Motor Frame	Part Number	Quantity	Description
56 or 140	416821-56-F	2	6205 ball bearings; double seals with Chevron SRI #2 grease; ABEC 1 tolerances; AFBMA-3 internal tolerances.
180	416821-56F	1	
	416821-56G	1	

11.4 Replacement Part Compatibility

Table 11.11 – Replacement Part Compatibility

Replacement Part Description	Version	VSM500		
		Version 1.0	Version 2.0	Version 3.0
Control Board Replacement Kit	1.0	Compatible	Not Compatible	Not Compatible
	2.0	Not Compatible	Compatible	Not Compatible
	3.0	Not Compatible	Not Compatible	Compatible
Cover with Display Only	1.0	Compatible	Compatible	Compatible ¹
	2.0	Compatible	Compatible	Compatible ¹
	3.0	Compatible ²	Compatible ²	Compatible
Cover with Display and Operator Controls	1.0	Compatible	Compatible	Compatible ¹
	2.0	Compatible	Compatible	Compatible ¹
	3.0	Compatible ²	Compatible ²	Compatible

¹The DeviceNet Communication LED is not present on the Version 1.0 or 2.0 cover assembly.

²The DeviceNet Communication LED will be illuminated while the unit is powered.

Maintenance Guidelines



ATTENTION: Only qualified personnel familiar with the construction and operation of this equipment and the hazards involved should install, adjust, operate, and/or service this equipment. Read and understand this instruction manual in its entirety before proceeding. Failure to observe this precaution could result in severe bodily injury or loss of life.

ATTENTION: After disconnecting input power, wait five minutes and check with a voltmeter to insure that DC bus capacitors are discharged. The voltmeter should read zero volts. Failure to observe these precautions could result in severe bodily injury or loss of life.

ATTENTION: To insure that the driven equipment is not unexpectedly started, turn off, lockout, and tag power source before proceeding. Failure to observe this precaution could result in bodily injury.

ATTENTION: The surface temperature of the drive and motor may become hot, which may cause injury.

Use the guidelines in this chapter to maintain the unit.

12.1 General Unit Maintenance

Check the following at regular intervals:

- Make sure the exterior is kept dry and free of dust, grease, oil, and dirt.
- Make sure the terminal connections, assembly screws, bolts, and nuts are tight.
- Make sure the unit is securely mounted to minimize vibration.

12.2 Motor Maintenance

Enclosed motors require minimal attention. At regular intervals, verify that external air passages of the motor do not become clogged with foreign material that will restrict the flow of air.

The ball bearings are deep-grooved, double-shielded bearings with sufficient lubricant packed into the bearings. You do not need to re-lubricate the bearings.

Technical Specifications

Unit Ratings

Input Ratings

AC line voltage:

- M/N __X_4_1_ 380 to 460 VAC, 3-phase
- M/N __X_2_1_ 200 to 230 VAC, 3-phase
- M/N __X_3_1_ 200 to 230 VAC, 1-phase
- M/N __X_1_1_ 115 VAC, 1-phase

AC line frequency:

- 48 to 62 Hz

AC line voltage variation:

- +/-10%

AC line current:

M/N	Input Voltage	Unit HP	Input Current
1_X_4_1_	460 VAC	1 HP	2.3 A rms continuous
2_X_4_1_	460 VAC	2 HP	3.7 A rms continuous
3_X_4_1_	460 VAC	3 HP	5.7 A rms continuous
5_X_4_1_	460 VAC	5 HP	9.0 A rms continuous
1_X_2_1_	230 VAC	1 HP	4.5 A rms continuous
2_X_2_1_	230 VAC	2 HP	7.6 A rms continuous
1_X_3_1_	230 VAC, 1-phase	1 HP	5.8 A rms continuous
2_X_3_1_	230 VAC, 1-phase	2 HP	14 A rms continuous
1_X_1_1_	115 VAC	1 HP	14 A rms continuous

Max allowable AC line distribution KVA:

- 100 KVA maximum for 115 VAC to 460 VAC distribution input.

Output Ratings

Horsepower ratings:

- 1, 2, 3 and 5 HP at 460 VAC
- 1, 2 HP at 230 VAC
- 1 HP at 115 VAC

Output voltage:

- M/N __X_4_1_ 380 to 460 VAC, 3-phase
- M/N __X_2_1_ 200 to 230 VAC, 3-phase
- M/N __X_3_1_ 200 to 230 VAC, 3-phase
- M/N __X_1_1_ 115 VAC, 3-phase

Maximum continuous output current:

M/N	Input Voltage	Unit HP	Output Current (Motor Rated Amps)
1_X_4_1_	460 VAC	1 HP	1.7 A
2_X_4_1_	460 VAC	2 HP	3.2A
3_X_4_1_	460 VAC	3 HP	4.5 A
5_X_4_1_	460 VAC	5 HP	6.9 A
1_X_2_1_	230 VAC	1 HP	3.4 A
2_X_2_1_	230 VAC	2 HP	6.4 A
1_X_3_1_	230 VAC, 1-phase	1 HP	3.4 A
2_X_3_1_	230 VAC, 1-phase	2 HP	6.4 A
1_X_1_1_	115 VAC	1 HP	6.8 A

Maximum output current:

M/N	Input Voltage	Unit HP	Maximum Output Current (150% Rated Amps)
1_X_4_1_	460 VAC	1 HP	2.55 A
2_X_4_1_	460 VAC	2 HP	4.8 A
3_X_4_1_	460 VAC	3 HP	6.75 A
5_X_4_1_	460 VAC	5 HP	10.35 A
1_X_2_1_	230 VAC	1 HP	5.1 A
2_X_2_1_	230 VAC	2 HP	9.6 A
1_X_3_1_	230 VAC, 1-phase	1 HP	5.1 A
2_X_3_1_	230 VAC, 1-phase	2 HP	9.6 A
1_X_1_1_	115 VAC	1 HP	10.2 A

Important: Maximum current ratings above are for the CT rating. When VT is selected, the maximum output current will be limited to 110%.

Output frequency:

- 0 to 120 Hz

Carrier frequency:

- 8 kHz

Operating Performance

Frequency regulation:

- 1% (1% of base speed, 180 to 1800 RPM, constant torque)

Speed range:

- 20:1 (90 to 1800 RPM, constant torque)

Voltage regulation:

- 3% of maximum rated voltage

Input power dip ride-through time:

- 500 msec minimum

Drive efficiency:

- >95% (at rated amps, 115 to 460 V, 60 Hz)

Operating Specifications

Operating temperature:

- 0 to 40°C (32°F to 104°F) ambient

Storage temperature:

- -40°C to 85°C (-40°F to 185°F)

Altitude:

- 1000 meters (3300 feet maximum) without derating.

For every 91.4 meters (300 feet) above 1000 meters, derate the current by 1%.
Above 3000 meters (10,000 feet), consult your Reliance Sales Office.

Humidity:

- 5% to 95%, non-condensing

Service factor:

- 1.0

Mechanical Specifications

Motor enclosure type:

- Totally enclosed, 24 VDC blower cooled (TEBC)

Required airflow:

- Required clearance for blower intake = 1 in

Protection rating:

- Drive section is NEMA Type 12, motor is IEC IP54

Nominal power dissipation for motor and drive combined:

Input Voltage	Unit HP	Nominal Watts Loss
460 VAC	1 HP	150 W
460 VAC	2 HP	250 W
460 VAC	3 HP	350 W
460 VAC	5 HP	550 W
230 VAC	1 HP	150 W
230 VAC	2 HP	250 W
230 VAC, 1-phase	1 HP	150 W
230 VAC, 1-phase	2 HP	260 W
115 VAC, 1-phase	1 HP	180 W

Weight:

Input Voltage	Unit HP	Weight
460 VAC	1 HP	38 lb
460 VAC	2 HP	49 lb
460 VAC	3 HP	59 lb
460 VAC	5 HP	59 lb
230 VAC	1 HP	38 lb
230 VAC	2 HP	49 lb
230 VAC, 1-phase	1 HP	38 lb
230 VAC, 1-phase	2 HP	49 lb
115 VAC, 1-phase	1 HP	38 lb

Shock:

- 15 G Operational, 30 G Non-Operational

Vibration:

- 1.0 G Operational, 2.5 G Non-Operational

Drive Protection/Fault Detection

Output overcurrent:

- Trip level = 200% of max peak rated current

Output ground fault:

- Trip level = 200% of max peak rated current DC bus overvoltage:

Line Voltage	Trip Level
460 VAC	830 VDC
230 VAC	415 VDC
115 VAC	208 VDC

Communication Fault (DeviceNet Option):

- Trip on communication loss or malfunction

Motor thermal overload:

- Trip time = 1 minute at 150% of rated current (CT)
- Trip time = 1 minute at 110% of rated current (VT)

DC bus undervoltage:

Line Voltage	Trip Level
460 VAC	435 VDC
380 VAC	358 VDC
230 VAC	218 VDC
115 VAC	109 VDC

I/O Specifications

Important: All signals are isolated from the incoming 3-phase power.

Analog inputs

0 to 10 V
Input impedance: 50 k Ω
Resolution: 0.11%

4 to 20 mA
Input impedance: 250 Ω
Resolution: 0.14%

Analog output

0 to 10 V
Minimum load resistance: 2 k Ω
Resolution: 0.4%

Logic inputs (Stop, Start, Reset, Fwd/Rev, RPM/%Load, Function Loss, Preset Speed)

24 VDC sourcing inputs
Maximum input voltage: 28.8 VDC
Input current @ 24 VDC: 10 mA
Maximum OFF state voltage: 5 VDC
Minimum ON state voltage: 15 VDC

Relay output (1 form A N.O. contact) isolated

Maximum current (resistive or inductive): 1 A
Minimum current: 10 mA
Maximum voltage: 28 VDC, 250 VAC

Product Features

The following features are standard on every VSM500 unit:

- Totally enclosed standard NEMA frame sizes with C-face and foot mounting. IEC frames and flanges are available.
- PWM (pulse-width modulated) drive section with a microprocessor-based V/Hz regulator.
- Design B inverter-duty motor section:
 - Class F non-hygroscopic insulation system resists heat, oil, and water.
 - Double-shielded bearings.
- Four-character, seven-segment LED display to indicate speed, %load, and diagnostic information.
- 0 to 10 VDC or 4 to 20 mA analog input for remote speed reference from a PLC or process controller.
- 0 to 10 VDC analog output to provide remote speed or %load indication.
- Seven selectable preset speeds.
- Form A contact output to indicate drive running or drive faulted condition.
- 500 ms power dip ride-through time.
- Protection features, including sensing for overtemperature, overcurrent, high DC bus voltage, low DC bus voltage, and surge suppression.
- Conduit cover can be rotated 180° to provide the appropriate display view in each application.
- User-selectable coast-to-rest (default) or ramp-to-rest (user option) stop.
- User-selectable variable torque (default) or constant torque (user option) operation.
- 8 kHz carrier frequency for quiet operation.
- Complies with UL 1995.

B.1 New Features in Version 3.0

- **Additional start mode selection.** Local operator control units can be controlled from either the operator controls or the terminal block.
- **Terminal block stop input.** The terminal block stop input and local operator control stop key are active for all start mode selections.
- **Zero speed operation.** The minimum speed has been reduced from 90 RPM (3 Hz) to zero.

- **Storage temperature range extended.** The storage temperature rating has been extended from 70°C to 85°C.
- **CE Mark.** The unit now conforms to the EMC and LVD directives for CE. An optional line filter is required.
- **CE Line Filter Option.** Single- and three-phase line filters can be mounted internally or are packaged for external mounting.
- **DeviceNet Communication Option.** A DeviceNet Option Board, purchased separately, is installed inside the unit. Refer to the DeviceNet Option board instruction manual, D2-3463, for more information.
- **Drive Parameters Added.** Drive display parameters and drive program parameters can be viewed or changed through a DeviceNet connection. Refer to the DeviceNet Communication Option Board instruction manual, D2-3463, for more information.

B.2 Application/Installation Considerations

Keep the following in mind if you are planning to upgrade your unit or are considering additional options:

- If you are replacing a Version 1.0 or 2.0 unit with a Version 3.0 unit, keep in mind that:
 - The minimum speed has been reduced from 90 RPM (3 Hz) to 0 RPM (0 Hz).
 - The terminal block stop input must be present for local operator control units.
- The DeviceNet communication option is not available for Version 1.0 or 2.0 units.
- The CE filter option is compatible with any version of the VSM500 integrated drive/motor; however, only Version 3.0 meets the CE requirement.
- The short cover has been replaced by a tall cover.

VSM500 System Diagram

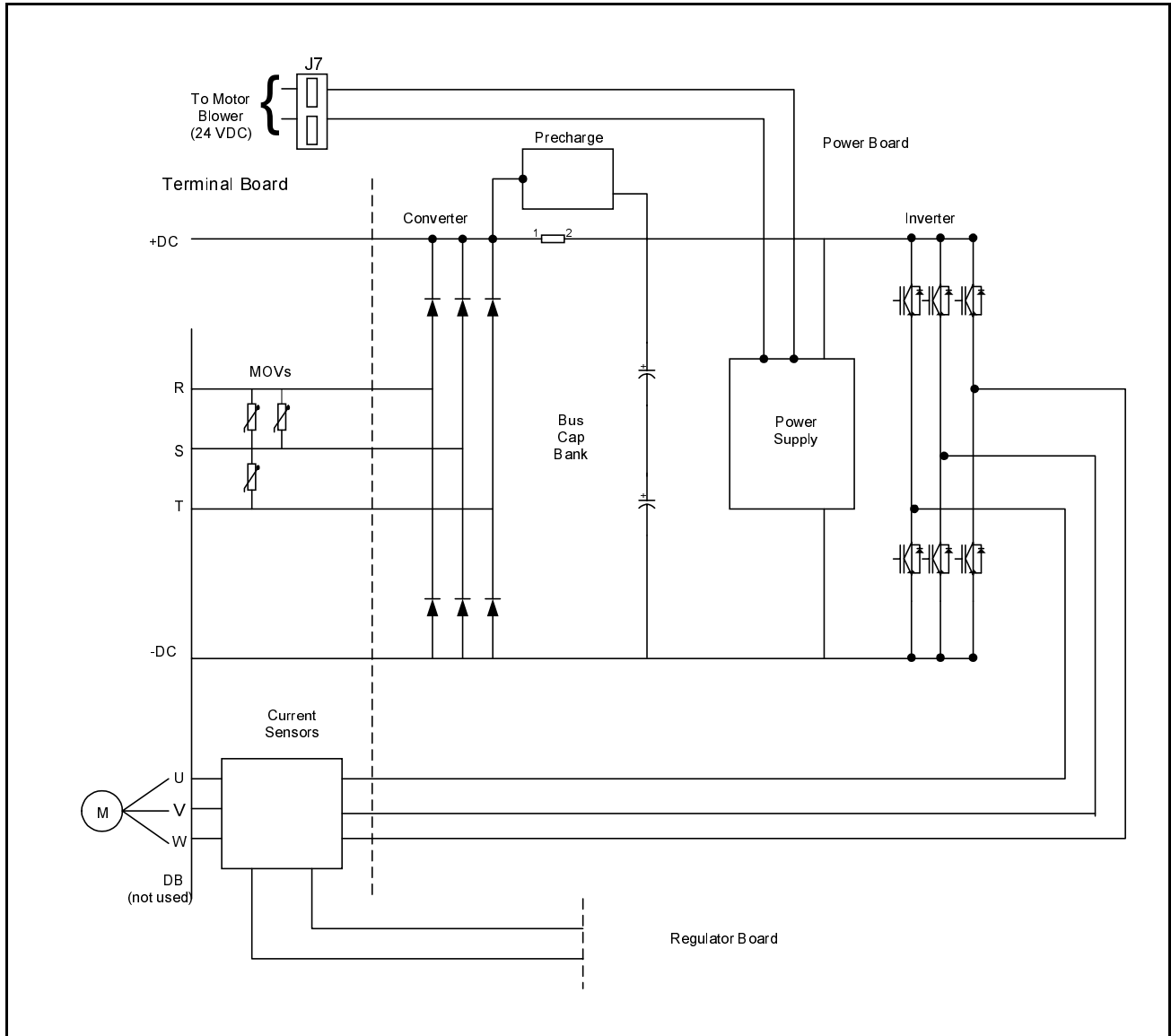
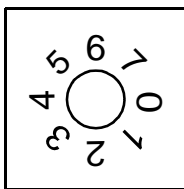

Figure C.1 – VSM500 System Diagram

Installation Record

Model Number:

Record the switch settings for your setup in the diagrams below:



- 0 = 1500 RPM (50 Hz)
- 1 = 1800 RPM (60 Hz)(Default)
- 2 = 2100 RPM (70 Hz)
- 3 = 2400 RPM (80 Hz)
- 4 = 2700 RPM (90 Hz)
- 5 = 3000 RPM (100 Hz)
- 6 = 3300 RPM (110 Hz)
- 7 = 3600 RPM (120 Hz)

**Max Speed Switch
(SW2)**

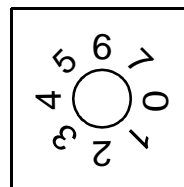

- 0 = 1 sec accel / 5 sec decel
- 1 = 5 sec (Default)
- 2 = 10 sec
- 3 = 15 sec
- 4 = 20 sec
- 5 = 30 sec
- 6 = 60 sec
- 7 = 90 sec

**Accel/Decel Switch
(SW1)**

<p>Power-Up Start Disabled</p> <p>1> Speed Reference From Operator Controls</p> <p>Relay Control Output: Running</p> <p>Auto Restart Disabled</p> <p>Variable Torque Curve</p> <p>Coast-to-Rest Stop</p> <p>Reverse Enabled</p> <p>0 Hz Minimum Speed</p> <p>1> Start from Operator Controls</p> <p>2> Parameter Settings from Setup Switches</p>	<div style="border: 1px solid black; padding: 5px; display: inline-block;"> <table border="0" style="width: 100%; border-collapse: collapse;"> <tr><td style="width: 20px;">→</td><td style="width: 20px;"><input type="checkbox"/></td><td style="width: 20px;"></td></tr> <tr><td>↺</td><td><input type="checkbox"/></td><td style="text-align: right;">Z</td></tr> <tr><td>ω</td><td><input type="checkbox"/></td><td></td></tr> <tr><td>↻</td><td><input type="checkbox"/></td><td></td></tr> <tr><td>↻</td><td><input type="checkbox"/></td><td></td></tr> <tr><td>↻</td><td><input type="checkbox"/></td><td></td></tr> <tr><td>↻</td><td><input type="checkbox"/></td><td></td></tr> <tr><td>↻</td><td><input type="checkbox"/></td><td></td></tr> <tr><td>↻</td><td><input type="checkbox"/></td><td></td></tr> <tr><td>↻</td><td><input type="checkbox"/></td><td></td></tr> <tr><td>↻</td><td><input type="checkbox"/></td><td></td></tr> </table> </div>	→	<input type="checkbox"/>		↺	<input type="checkbox"/>	Z	ω	<input type="checkbox"/>		↻	<input type="checkbox"/>		↻	<input type="checkbox"/>		↻	<input type="checkbox"/>		↻	<input type="checkbox"/>		↻	<input type="checkbox"/>		↻	<input type="checkbox"/>		↻	<input type="checkbox"/>		↻	<input type="checkbox"/>		<p>Power-Up Start Enabled</p> <p>Analog Speed Reference From Terminal Block</p> <p>Relay Control Output: Faulted</p> <p>Auto Restart Enabled</p> <p>Constant Torque Curve</p> <p>Ramp-to-Rest Stop</p> <p>Reverse Disabled (Reverse Lockout)</p> <p>Minimum Speed From Terminal Block Inputs</p> <p>Start from Terminal Block</p> <p>Parameter Settings from EEPROM Memory</p>
→	<input type="checkbox"/>																																		
↺	<input type="checkbox"/>	Z																																	
ω	<input type="checkbox"/>																																		
↻	<input type="checkbox"/>																																		
↻	<input type="checkbox"/>																																		
↻	<input type="checkbox"/>																																		
↻	<input type="checkbox"/>																																		
↻	<input type="checkbox"/>																																		
↻	<input type="checkbox"/>																																		
↻	<input type="checkbox"/>																																		
↻	<input type="checkbox"/>																																		

**Setup Slide Switch
(SW3)**

1> Switches 2 and 9 apply only to local operator control units.
 2> Switch 10 is used only with the DeviceNet Communication Option.

Replacing the Drive Section or the Motor Section



ATTENTION: Only qualified personnel familiar with the construction and operation of this equipment and the hazards involved should install, adjust, operate, and/or service this equipment. Read and understand this instruction manual in its entirety before proceeding. Failure to observe this precaution could result in severe bodily injury or loss of life.

ATTENTION: All adjustments to these components should be made with power removed. Failure to observe this precaution could result in severe bodily injury or loss of life.

ATTENTION: After disconnecting input power, wait five minutes and check with a voltmeter to insure that DC bus capacitors are discharged. The voltmeter should read zero volts. Failure to observe this precaution could result in severe bodily injury or loss of life.

Before beginning the replacement procedure, be sure to take the following precautions:

- Step 1. Turn off, lockout, and tag AC input power to the unit.
- Step 2. Wait five minutes. Then remove the cover and use a voltmeter to verify that the DC bus capacitors are discharged. The voltmeter should read zero volts. Refer to figure 5.2 in chapter 5 for the DC bus test points.

Refer to figure E.1 and use the following procedure to replace the drive section or the motor section of the VSM500 unit.

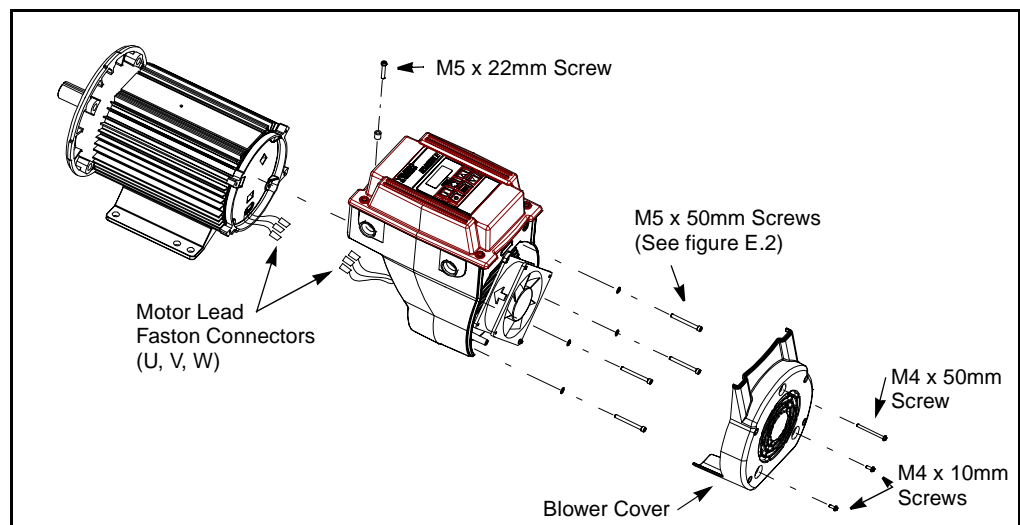

Figure E.1 – Replacing the Drive Section or the Motor Section

- Step 1. Loosen, but do not remove, the M5 x 22mm screw located on the top of the motor section.
- Step 2. Using a 4 mm T-handle hex driver, remove the four M5 x 50mm socket head cap screws that secure the drive section and the motor section together.
- Step 3. Slide the drive section away from the motor section.
- Step 4. Disconnect the motor lead Faston connectors.
- Step 5. Replace either the drive section or the motor section.
- Step 6. Reconnect the Faston motor leads. The wires are labeled on both the motor and drive sections. Connect U to U, V to V, and W to W.
- Step 7. Slide the drive section onto the motor section. Verify that the slot in the top of the drive section fits securely around the screw on the motor section.
- Step 8. Remove the three screws from the blower cover. Remove the blower cover.
- Step 9. Secure the drive section to the motor section using the four M5 x 50mm screws removed in step 2. See figure E.2 for the hole locations. Tighten screws first to 1.5 Nm (13 in-lb). Then torque to 3.9 Nm (35 in-lb) using a cross-rotational pattern.

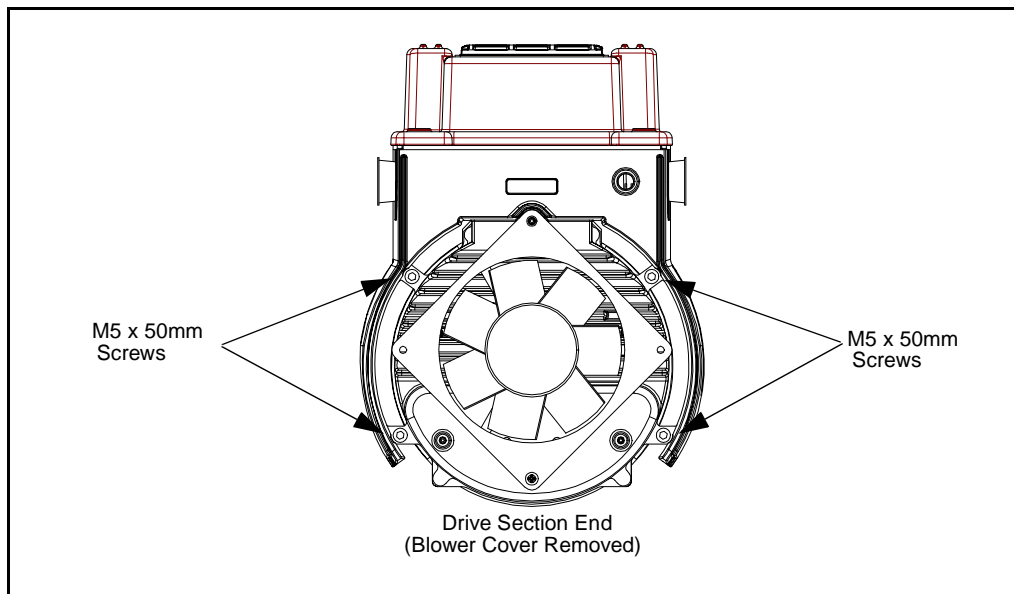

Figure E.2 – Hole Location

- Step 10. Tighten the M5 x 22mm screw on top of the motor section. Torque to 2.3 Nm (20 in-lb).
- Step 11. Place the M4 x 50mm screw (top screw) into the blower cover. Slide the blower cover over the blower using the screw to aid alignment. Insert and tighten the bottom two M4 x 10mm screws on the blower cover. Torque blower cover screws to 2.3 Nm (20 in-lb).

Important: The blower covers on the 1 and 2 HP units have a spacer on the top M4 x 50 mm screw. Verify that this spacer is in place before attaching the blower cover.

CE Conformity

This unit is a component intended for implementation in machines or systems for the industrial environment. It is CE marked for conformity to the Low Voltage (LV) Directive 73/23/EEC when installed as described. It also has been tested to meet the Council Directive 89/336 Electromagnetic Compatibility (EMC). The standards used for this testing are LV: EN50178, EN60204-1, EMC: EN61800-3, EN50081-1, EN50082-2.

Important: The conformity of the drive and filter to any standard does not guarantee that the entire installation will conform. Many other factors can influence the total installation and only direct measurements can verify total conformity. It is therefore the responsibility of the machine manufacturer to ensure that the conformity is met.

Copies of the Declaration of Conformity (DOC) may be obtained by contacting the Rockwell AutoFax service at 440-646-7777.

F.1 Essential Requirements for a Conforming EMC Installation

The following items are required for CE conformance:

- A CE filter (see table 1.2) must be installed to reduce conducted emissions.
- Grounding of equipment and cable shields must be solid, with low impedance connections.
- All control and signal wiring must use shielded cable or be in grounded metal conduit.

F.2 Low Voltage Directive 73/23/EEC Compliance

This product complies with Low Voltage Directive 72/23/EEC when conforming with the following installation requirements:

Review ATTENTION statements throughout this manual prior to installing the product.

Install the product with a fixed connection to the earth. The use of residual-current-operated protective devices (RCDs) or ground fault indicators is not recommended. If unavoidable, the VSM500 unit is compatible with type B RCDs only.

Install the product in an appropriate or suitable enclosure.

A

- AC input disconnect, installing, 4-1
- AC input power terminal block
 - connections, 5-2
 - location, 2-1
 - tightening torque, 5-1
 - wiring, 5-1
- Accel / decel switch
 - adjusting, 8-4
 - location, 2-1, 8-2
- Analog output
 - selecting RPM or %load, 7-7
 - wiring, 7-5
- Application/installation considerations, B-2
- Assistance from Reliance Electric, Checklist -1
- Auto restart switch
 - adjusting, 8-7
 - location, 8-2

B

- Branch circuit protection, installing, 4-1

C

- CE conformity, F-1
- CE filter option kits, 1-5
- COMM LED, 1-3, 1-4
- Communications (COMM) LED, 1-3, 1-4
- Control signal terminal block
 - location, 2-1, 7-2, 7-3
 - wiring, 7-1 to 7-14
- Cover
 - attaching, 9-2
 - clearance, 2-2
 - opening, 5-2
 - rotating, 9-3

D

- Declaration of Conformity, F-1
- Default switch settings, 8-2
- DeviceNet communication option
 - description, B-2
 - option kit model number, 1-5
 - parameter mode selection, 8-11
- Display
 - local operator control unit, 1-4
 - selecting RPM or %load, 7-7
 - standard unit, 1-2
- Display board connector, location, 2-1
- Drive section
 - description, 1-1
 - replacing, E-1

E

- Emergency stop, installing, 6-1
- EN 60204-1 compliance, 6-1

F

- Fault codes, 11-2 to 11-4
- Faults, clearing, 1-5, 11-2
- Features, B-1
 - new features in version 3.0, B-1
- Forward control
 - reverse disable switch, 8-9
 - wiring, 7-13
- Function loss, wiring, 7-4

G

- Grounding, 5-3

H

- Handling and lifting guidelines, 2-4

I

- Identifying your unit, 1-1 to 1-5
- Input isolation transformers, installing, 4-2
- Input line reactors, 4-2
- Installation
 - AC input disconnect, 4-1
 - AC input power, 5-1
 - branch circuit protection, 4-1
 - check with power off, 9-1
 - checklist, Checklist -1
 - considerations, B-2
 - emergency stop, 6-1
 - grounding, 5-3
 - input isolation transformers, 4-2
 - mounting, 3-1 to 3-2
 - planning, 2-1 to 2-2
 - wire routing guidelines, 2-3
- Installation record, D-1

L

- LED, communications (COMM), 1-3, 1-4, 11-9
- LED, reverse, 1-2, 1-4
- Local operating control unit
 - display, 1-4
 - reverse LED, 1-4
- Local operator control unit
 - communications (COMM) LED, 1-4
 - general information, 1-3
 - key descriptions, 1-4
 - using terminal block control, 1-3
 - using the operator controls, 1-3, 1-5
- Low Voltage Directive compliance, F-1

M

- Maintenance guidelines, 12-1
- Maximum speed rotary switch
 - adjusting, 8-3
 - location, 2-1, 8-2
- Minimum speed, setting, 8-9
- Model number format, 1-1
- Motor maintenance, 12-1
- Motor rotation, changing the direction of, 9-2
- Motor section
 - description, 1-1
 - replacing, E-1
- Mounting dimensions, 3-2

N

- NEMA frames, mounting dimensions, 3-2

O

- Operating speed, setting, 10-1
- Option kits, 1-5

P

- Power-up start switch
 - adjusting, 8-6
 - location, 8-2

R

- Relay control output
 - switch, 8-7
 - wiring, 7-6
- Replacement part compatibility, 11-9
- Replacement parts, 11-7
- Reset control, wiring, 7-14
- Reverse control
 - reverse disable, 8-9
 - wiring, 7-13
- Reverse LED, 1-2, 1-4
- Rotary switches
 - adjusting the accel / decel time using, 8-4
 - adjusting the maximum speed using, 8-3

S

- Setup slide switch, location, 2-1
- Slide switch, setup
 - auto restart, 8-7
 - minimum speed select, 8-9
 - parameter mode for DeviceNet option, 8-11
 - power-up start, 8-6
 - relay control output, 8-7
 - reverse disable, 8-9
 - speed reference select, 8-6
 - start mode select, 8-11
 - stop type, 8-9
 - torque curve, 8-8
- Specifications, A-1 to A-5

Speed reference
 0 to 10 VDC external speed reference,
 wiring, 7-10
 4 to 20 mA external speed reference, wiring, 7-
 11
 checking, 9-4
 preset speed inputs, 7-8
 signal potentiometer, 7-9
 wiring, 7-7 to 7-11

Standard unit
 communications (COMM) LED, 1-3
 general information, 1-2
 reverse LED, 1-2

Start control, wiring, 7-9, 7-12

Starting the unit
 using local operator controls, 1-3, 1-5
 using terminal block control, 7-12

Stop control
 stop type, 8-9
 stop type switch location, 8-2
 wiring, 7-12

Stopping the unit
 using local operator controls, 1-3, 1-5
 using terminal block control, 1-3, 7-12

Switch
 accel / decel, 8-4
 maximum speed, 8-3
 setup, 8-5 to 8-11

System diagram, C-1

T

Technical assistance, Checklist -1

Tightening torque
 AC input power terminal block, 5-1
 blower cover screws, E-2
 control signal terminal block, 7-1
 cover screws, 9-2
 drive section screws, E-2
 ground screw, 5-3

Torque curve
 selecting, 8-8
 switch location, 8-2

Troubleshooting, 11-1 to 11-6

V

Verifying the setup, 8-1

W

Wire routing guidelines, 2-3

Wire size
 AC input power terminal terminal block, 5-1
 control signal terminal block, 7-1

Wiring diagrams, Checklist -2, 7-2, 7-3, 7-4 to 7-14

Documentation Improvement Form

Use this form to give us your comments concerning this publication or to report an error that you have found. For convenience, you may attach copies of the pages with your comments. After you have completed this form, please return it to:

Reliance Electric
Technical Documentation
24800 Tungsten Road
Cleveland, Ohio 44117

Fax: 216.266.7785

Publication Name: Installing and Operating the VSM500 Integrated Drive/Motor V3.0	
Publication Number: D2-3400-3	Publication Date: March 2000

Comments: _____

Your Name:	Date:
Company Name:	Phone: ()
Address:	

Thank you for your comments.

Technical Writing Internal Use	
Date:	DIF Number:
Follow-Up Action:	

Reach us now at www.rockwellautomation.com

Wherever you need us, Rockwell Automation brings together leading brands in industrial automation including Allen-Bradley controls, Reliance Electric power transmission products, Dodge mechanical power transmission components, and Rockwell Software. Rockwell Automation's unique, flexible approach to helping customers achieve a competitive advantage is supported by thousands of authorized partners, distributors and system integrators around the world.

Americas Headquarters, 1201 South Second Street, Milwaukee, WI 53204, USA, Tel: (1) 414 382-2000, Fax: (1) 414 382 4444

European Headquarters SA/NV, avenue Hermann Debroux, 46, 1160 Brussels, Belgium, Tel: (32) 2 663 06 00, Fax: (32) 2 663 06 40

Asia Pacific Headquarters, 27/F Citicorp Centre, 18 Whitfield Road, Causeway Bay, Hong Kong, Tel: (852) 2887 4788, Fax: (852) 2508 1846

Reliance Electric Standard Drives Business, 24800 Tungsten Road, Cleveland, OH 44117, USA, Tel: (1) 888 374 8370, Fax: (216) 266 7095



**Rockwell
Automation**