

Installation and Operation of the SP100 A-C Drive Single-Phase Input Three-Phase Output

1 HP @ 230 VAC

M/N 1AU2001

Instruction Manual D2-3355

 **Rockwell** Automation

Reliance Electric

The information in this user's manual is subject to change without notice.

DANGER

ONLY QUALIFIED ELECTRICAL PERSONNEL, FAMILIAR WITH THE CONSTRUCTION AND OPERATION OF THIS EQUIPMENT AND THE HAZARDS INVOLVED, SHOULD INSTALL, ADJUST, OPERATE, AND/OR SERVICE THIS EQUIPMENT. READ AND UNDERSTAND THIS INSTRUCTION MANUAL IN ITS ENTIRETY BEFORE PROCEEDING. FAILURE TO OBSERVE THIS PRECAUTION COULD RESULT IN SEVERE BODILY INJURY OR LOSS OF LIFE.

WARNING

THE USER MUST PROVIDE AN EXTERNAL, HARDWIRED EMERGENCY STOP CIRCUIT OUTSIDE OF THE DRIVE CIRCUITRY. THIS CIRCUIT MUST DISABLE THE SYSTEM IN CASE OF IMPROPER OPERATION. UNCONTROLLED MACHINE OPERATION MAY RESULT IF THIS PROCEDURE IS NOT FOLLOWED. FAILURE TO OBSERVE THIS PRECAUTION COULD RESULT IN BODILY INJURY.

CAUTION: The user is responsible for conforming with all applicable local, national, and international codes. Failure to observe this precaution could result in damage to, or destruction of, the equipment.

Reliance® is a registered trademark of Reliance Electric Company or its subsidiaries.

© Copyright Reliance Electric Industrial Company 1996.

Table of Contents

1.0	Introduction to the SP100	1-1
1.1	General Description	1-1
1.2	Standard Features	1-1
1.3	Operating the Drive	1-2
2.0	Installation and Wiring	2-1
2.1	Mounting the Drive	2-1
2.2	Installing an A-C Input Disconnect	2-4
2.3	Installing Branch Circuit Protection	2-4
2.4	Installing Input Isolation Transformers	2-4
2.5	Wiring A-C Power to the Drive	2-5
2.6	Installing the Motor	2-7
2.7	Grounding the Drive and Motor	2-7
2.8	Installing an Emergency Stop	2-8
2.8.1	Compliance with EN 60204-1: 1992	2-8
2.9	Wiring the Control Terminal Strip	2-8
2.9.1	Relay Output	2-9
2.9.2	Wiring the Speed Reference Signal Potentiometer	2-9
2.9.3	Wiring an External 10 Volt Speed Reference	2-10
2.9.4	Wiring Function Loss To Stop the Drive	2-11
2.9.5	Wiring Forward / Reverse Control	2-12
2.9.6	Wiring Reset Control	2-12
2.9.7	Wiring Start / Stop Control	2-13
3.0	Drive Configuration	3-1
3.1	Adjusting the Maximum Speed	3-2
3.2	Adjusting the Minimum Speed	3-2
3.3	Adjusting the Acceleration / Deceleration Time	3-3
3.4	Adjusting Torque Boost	3-3
3.5	Drive Configuration Switches (SW1)	3-4
3.5.1	Power-Up Start (SW1, Position 1)	3-5
3.5.2	Coast-to-Rest/Ramp-to-Rest (SW1, Position 2)	3-5
3.5.3	Relay Output Select (SW1, Position 3)	3-5
3.5.4	Auto-Restart (SW1, Position 4)	3-5
3.5.5	Carrier Switching Frequency (SW1, Position 5)	3-6
3.5.6	Motor Base Frequency (SW1, Position 6)	3-7
3.5.7	Current Limit (SW1, Positions 7 and 8)	3-7
3.6	Motor Current Selection Switch (SW2)	3-7
4.0	Initial Start-up Procedures	4-1
4.1	Checking the Installation with the Power Off	4-1
4.2	Checking the Direction of Rotation	4-2
4.3	Checking the Speed Reference Voltage	4-3
4.4	Testing the Drive Under Load	4-3
5.0	Diagnostics and Troubleshooting	5-1
5.1	Status LED	5-1
5.2	Internal Diagnostics	5-2
5.3	Troubleshooting Guidelines	5-4

Appendices

Appendix A	
Technical Specifications	A-1
Appendix B	
Component Settings	B-1

List of Figures

Figure 2.1	- Mounting Dimensions	2-3
Figure 2.2	- Component Layout	2-6
Figure 2.3	- Control Terminal Strip	2-9
Figure 2.4	- Speed Reference Potentiometer Installation	2-10
Figure 2.5	- External 10 VDC Speed Reference Wiring	2-11
Figure 2.6	- Function Loss Control Wiring	2-11
Figure 2.7	- Forward / Reverse Control Wiring	2-12
Figure 2.8	- Reset Control Wiring	2-12
Figure 2.9	- Start / Stop Control Wiring	2-13
Figure 3.1	- Drive Configuration DIP Switch (SW1)	3-4
Figure 3.2	- Motor Current Selection Switch (SW2)	3-8

List of Tables

Table 1.1	- SP100 A-C Drive Ratings (M/N 1AU2001)	1-1
Table 2.1	- A-C Branch Circuit Protection	2-4
Table 3.1	- Current Limit Settings	3-7
Table 5.1	- LED Status Indications	5-1
Table 5.2	- Drive Faults	5-2
Table 5.3	- Troubleshooting	5-4

1.0 INTRODUCTION TO THE SP100

The products described in this manual are manufactured and distributed by Reliance Electric Industrial Company.

1.1 General Description

The SP100 A-C drive is an open loop volts/hertz PWM inverter with a single-phase input and a 3-phase output. It controls voltage and frequency to the motor, with the frequency proportional to a commanded 0 to 10 volt reference. Motor speed is dependent on output frequency and load.

The drive can control three-phase A-C motors rated up to 1 HP at 230 VAC. Refer to table 1.1.

Table 1.1 - SP100 A-C Drive Ratings (M/N 1AU2001)

Input (50-60 Hz Single Phase)		Output (Three Phase)	
Volts	Amps	Volts	Amps
115 VAC	9.0	115 VAC	3.6
230 VAC	9.0	230 VAC	3.6

The SP100 drive has a compact, open chassis design, consisting of a single printed circuit board and an integrated power module mounted on a heatsink. It must be installed in an electrical enclosure.

Switches and potentiometers mounted on the printed circuit board are used to configure the drive. The configuration is preset at the factory but can be adjusted by the user for customized applications. A terminal strip is provided for connection to the drive's digital and analog control inputs. All terminal strip inputs are isolated from the A-C line and the D-C bus. A relay contact output can be configured to indicate that the drive is running or that a drive fault has occurred. An LED is provided for diagnostics.

1.2 Standard Features

The SP100 drive has the following features:

- Open-chassis design mounted on a heatsink for installation within electrical enclosures
- Pulse-width modulation (PWM) voltage and frequency control
- IGBT power devices in an integrated power module
- User-selectable carrier switching frequency, 8 KHz or 4 KHz
- Digital inputs for asserting Start, Stop, Forward / Reverse, Fault Reset, and Function Loss commands
- Speed reference using an operator-mounted 5K ohm potentiometer or a remote 0 to 10 VDC signal

- User-selectable relay contact output for Drive Running or Drive Fault indication
- User-selectable power-up start, auto-restart, and coast-to-rest or ramp-to-rest stop functions
- Application adjustments using potentiometers for maximum speed, minimum speed, torque boost, and acceleration / deceleration time
- User-selectable motor base frequency, 50 or 60 Hz
- 16 user-selectable motor current values for overload protection (1.0 - 3.6 amp)
- User-selectable current limiting (50%, 100%, 125%, 150%)
- LED for diagnostics and drive status indication
- Drive protection features include input surge suppression, current limit, output short circuit, output ground fault, D-C bus overload, drive thermal overload, and motor overload
- D-C bus terminations provided for connection to user-supplied snubber in regenerative applications

1.3 Operating the Drive

The operation of the SP100 drive is controlled by the following six input signals, referred to as control signals throughout this manual. The wiring of the control signals is described in chapter 2. Set-up and adjustment is described in chapter 3.

Start: The SP100 drive is designed to start when a momentary pushbutton is pressed, producing a high-to-low transition at the drive's Start input. A maintained contact may be used, but the contact must be opened and reclosed to start the drive again. Both the Stop and Function Loss input signals must be present, and there must be no active faults.

Stop: A signal must be maintained at the Stop input in order for the drive to run. If the signal is interrupted, the drive will coast-to-rest (default) or ramp-to-rest (user option). The signal must be restored and the Start command reasserted in order to restart the drive.

Function Loss: A signal must be maintained at the Function Loss input in order for the drive to run. Interrupting the Function Loss signal will cause the drive to coast-to-rest. The Function Loss signal must be restored and the Start command reasserted in order to restart the drive. Function Loss overrides all other signals and is normally used as a run permissive or interlock.

Reset: A high-to-low transition at the Reset input clears a drive fault once the appropriate corrective action has been taken. After resetting the drive, the Start command must be reasserted.

Forward/Reverse: Switching the Forward/Reverse input causes the motor to coast-to-rest and then accelerate in the opposite direction.

Speed Reference: A speed reference potentiometer or an external 0 to 10 VDC speed reference is used to adjust the motor's speed over the range from the configured minimum speed to the configured maximum speed.

2.0 INSTALLATION AND WIRING

DANGER

ONLY QUALIFIED ELECTRICAL PERSONNEL, FAMILIAR WITH THE CONSTRUCTION AND OPERATION OF THIS EQUIPMENT AND THE HAZARDS INVOLVED, SHOULD INSTALL, ADJUST, OPERATE, AND/OR SERVICE THIS EQUIPMENT. READ AND UNDERSTAND THIS INSTRUCTION MANUAL IN ITS ENTIRETY BEFORE PROCEEDING. FAILURE TO OBSERVE THIS PRECAUTION COULD RESULT IN SEVERE BODILY INJURY OR LOSS OF LIFE.

DANGER

THIS EQUIPMENT IS AT LINE VOLTAGE WHEN A-C POWER IS CONNECTED. DISCONNECT AND LOCKOUT ALL UNGROUNDED CONDUCTORS OF THE A-C POWER LINE BEFORE WORKING ON THE DRIVE. FAILURE TO OBSERVE THESE PRECAUTIONS COULD RESULT IN SEVERE BODILY INJURY OR LOSS OF LIFE.

CAUTION: The user is responsible for conforming with all applicable local, national, and international codes. Failure to observe this precaution could result in damage to, or destruction of, the equipment.

It is the user's responsibility to ensure that this equipment is installed properly according to this manual and in conformance with all applicable codes. The local inspecting agency should be consulted for information about any local, national, or international codes that may apply.

Review all installation and wiring instructions thoroughly before proceeding. Throughout the installation, use figure 2.2 to locate wiring termination points, adjustment potentiometers, and configuration switches.

2.1 Mounting the Drive

WARNING

THE SP100 DRIVE'S HEATSINK CAN REACH A TEMPERATURE OF 110°C (230°F). CARE SHOULD BE TAKEN TO ENSURE THAT MOUNTING SURFACES ARE GUARDED AGAINST COMING INTO CONTACT WITH PERSONNEL OR WITH HEAT-SENSITIVE MATERIALS. FAILURE TO OBSERVE THIS PRECAUTION COULD RESULT IN BODILY INJURY.

The SP100 is an open-chassis drive which must be mounted in a protective electrical enclosure. Planning the installation is necessary to ensure that the drive environment and operating conditions are

satisfactory. Read and follow the requirements given below before proceeding with the installation:

- Locate the drive where it will have unrestricted clearance as shown in figure 2.1. Mount the drive on a flat surface with the fins in a vertical position.
- Make sure that the drive will be kept clean and away from oil, coolants, or other airborne contaminants.
- Check that the enclosure will allow sufficient ventilation for the drive. The temperature within the enclosure must remain between 0 to 55°C (32°F to 131°F). The drive's heatsink must not exceed 110°C (230°F).
- Verify that the relative humidity will be between 5 and 95%, non-condensing.
- Do not install the drive above 1000 meters (3300 ft) without derating. For every 91.4 meters (300 ft) above 1000 meters, derate the current rating by 1%. Consult Reliance Electric for operation above 3,000 meters (10,000 ft).

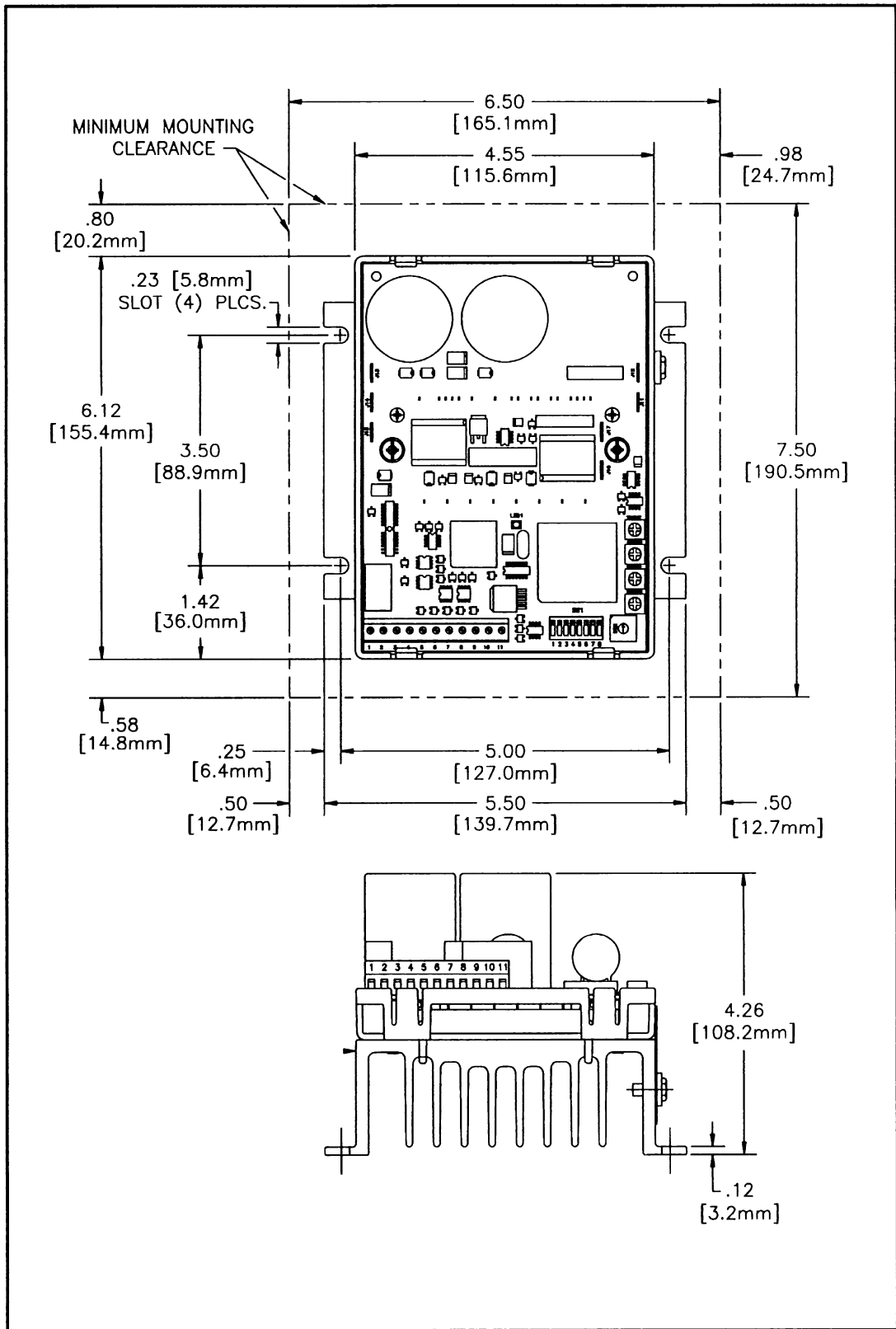

Figure 2.1 - Mounting Dimensions

2.2 Installing an A-C Input Disconnect

DANGER

THE NEC, CEC, AND IEC REQUIRE THAT AN INPUT DISCONNECT BE PROVIDED IN THE INCOMING POWER LINES. FAILURE TO OBSERVE THIS PRECAUTION COULD RESULT IN SEVERE BODILY INJURY OR LOSS OF LIFE.

An A-C input disconnect must be provided in the incoming power lines in accordance with NEC/CEC guidelines. Size the disconnect according to the in-rush current, as well as any additional loads the disconnect may supply. The trip rating for the in-rush current (10 to 12 times full load current) should be coordinated with that of the input transformer, if used. See section 2.4.

2.3 Installing Branch Circuit Protection

DANGER

THE NEC/CEC REQUIRES THAT UPSTREAM BRANCH PROTECTION BE PROVIDED TO PROTECT INPUT POWER WIRING. THE INPUT FUSE RATINGS LISTED IN TABLE 2.1 ARE APPLICABLE FOR ONE DRIVE PER BRANCH CIRCUIT. NO OTHER LOAD CAN BE APPLIED TO THAT FUSED BRANCH CIRCUIT. FAILURE TO OBSERVE THIS PRECAUTION COULD RESULT IN SEVERE BODILY INJURY OR LOSS OF LIFE.

Install the required, user-supplied branch circuit protection fuses according to NEC/CEC guidelines. The fuses must be installed in the A-C line before the drive input terminals. Refer to table 2.1 for fuse ratings.

Table 2.1 - A-C Branch Circuit Protection

Input Voltage	Input Current	Fuse Rating*
115 VAC	9.0 A	15 A
230 VAC	9.0 A	15 A

*Recommended fuse type: UL Class J or CC, 600 V time delay.

2.4 Installing Input Isolation Transformers

CAUTION: Distribution system capacity above the maximum recommended system KVA (25 KVA for 115 VAC single-phase, 50 KVA for 230 VAC single-phase, 5% impedance) requires using an isolation transformer, a line reactor, or other means of adding similar impedance. Failure to observe this precaution could result in damage to, or destruction of, the equipment.

Depending upon the requirements of the application, input isolation transformers might be needed to help eliminate the following:

- Damaging A-C line voltage transients from reaching the drive.
- Line noise from the drive being fed back to the incoming power source.
- Damaging currents that could develop if a point inside the drive becomes grounded.

Observe the following guidelines when installing an input isolation transformer:

- A power-disconnecting device must be installed between the power line and the primary of the transformer.
- If the power-disconnecting device is a circuit breaker, the circuit breaker trip rating must be coordinated with the in-rush of current (10 to 12 times full load current) of the transformer.
- An input transformer rated more than 50 KVA for 230 VAC with less than 5% impedance should **NOT** be used directly ahead of the drive without additional impedance between the drive and the transformer.

2.5 Wiring A-C Power to the Drive

DANGER

IF THE DISTRIBUTION SYSTEM CAPACITY EXCEEDS THE DRIVE'S MAXIMUM SYMMETRICAL FAULT SHORT-CIRCUIT CURRENT OF 5,000 AMPS, ADDITIONAL IMPEDANCE SHOULD BE ADDED TO THE A-C LINE SUPPLYING THE DRIVE TO LIMIT AVAILABLE CURRENT IN THE EVENT OF A FAULT. FAILURE TO OBSERVE THIS PRECAUTION COULD RESULT IN SEVERE BODILY INJURY OR LOSS OF LIFE.

Connect the incoming A-C line to terminals R/L1 and S/L2, on the right side of the drive, as shown in figure 2.2. Observe the following guidelines when wiring A-C power:

- Verify that the input power to the drive corresponds to the drive voltage and frequency and that the plant supply is of sufficient capacity to support the input current requirements. Refer to Appendix A, Technical Specifications.
- Size the A-C line conductors for the drive rating and in accordance with all applicable local, national, and international codes.

NOTE: An optional user-provided single-phase input contactor can be installed between the A-C line source and the drive power input terminals.

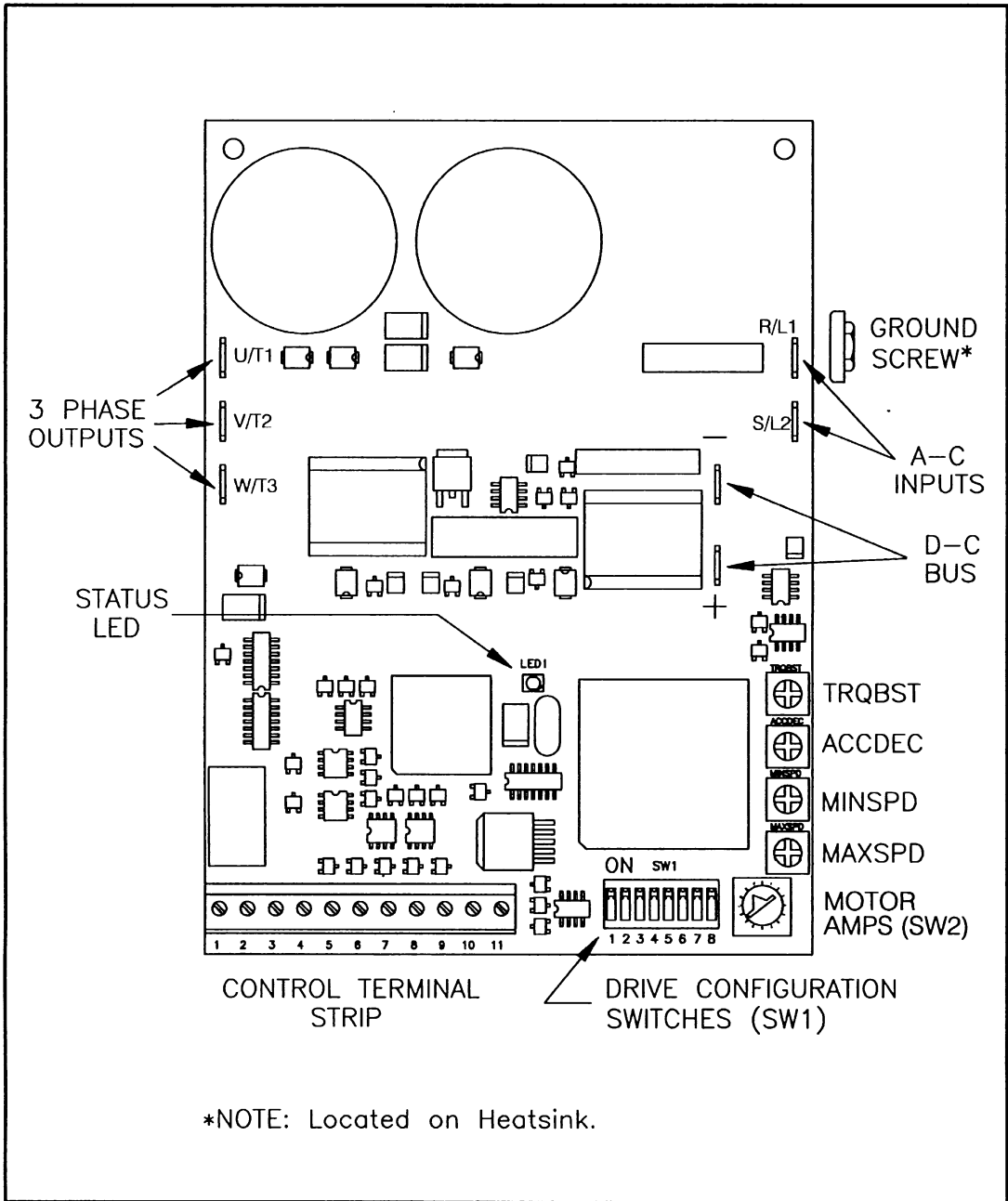

Figure 2.2 - Component Layout

2.6 Installing the Motor

CAUTION: Use of power correction capacitors on the output of the drive can result in erratic operation of the motor, nuisance tripping, and/or permanent damage to the drive. Remove power factor capacitors from the motor before proceeding. Failure to observe this precaution could result in damage to, or destruction of, the equipment.

Connect the motor to drive output terminals, U/T1, V/T2, and W/T3, on the left side of the drive, as shown in figure 2.2.

Observe the following guidelines:

- Verify that the motor has the appropriate rating to match the A-C line voltage. Check the motor nameplate data against table 1.1.
- Install the motor according to the motor's instruction manual.
- Size the motor conductors in accordance with all applicable local, national, and international codes.
- Verify that the total lead length on each phase does not exceed 30 meters (100 ft) per phase.
- Verify that the motor is properly aligned with the driven machine to minimize unnecessary motor loading from shaft misalignment.
- **DO NOT** connect braking resistors to the SP100 drive. The drive has no internal snubber capability. An external dynamic braking kit can be provided if needed. Contact your Reliance Electric representative.

NOTE: An optional user-provided three-phase output contactor can be installed between the drive and the motor.

2.7 Grounding the Drive and Motor

DANGER

THE USER IS RESPONSIBLE FOR CONFORMING WITH ALL LOCAL, NATIONAL, AND INTERNATIONAL CODES APPLICABLE TO THE GROUNDING OF THIS EQUIPMENT. FAILURE TO OBSERVE THIS PRECAUTION COULD RESULT IN SEVERE BODILY INJURY OR LOSS OF LIFE.

Observe the following guidelines to properly ground the drive and motor:

- Connect the ground wire brought in with the incoming A-C power to the drive's grounding screw, located on the heatsink (see figure 2.2).
- Connect a suitable equipment grounding conductor unbroken from the drive to an earth ground.
- Connect a suitable equipment grounding conductor to the motor frame, the drive enclosure, and the transformer (if used). Run each conductor unbroken to the earth ground.
- Connect a suitable grounding conductor from each conduit to the drive ground point.

2.8 Installing an Emergency Stop

WARNING

THE USER MUST PROVIDE AN EXTERNAL, HARDWIRED EMERGENCY STOP CIRCUIT OUTSIDE OF THE DRIVE CIRCUITRY. THIS CIRCUIT MUST DISABLE THE SYSTEM IN CASE OF IMPROPER OPERATION. UNCONTROLLED MACHINE OPERATION MAY RESULT IF THIS PROCEDURE IS NOT FOLLOWED. FAILURE TO OBSERVE THIS PRECAUTION COULD RESULT IN BODILY INJURY.

Depending upon the requirements of the application, the SP100 drive's Stop input can be configured to provide either a coast-to-rest or a ramp-to-rest operational stop without physical separation of the power source from the motor. The drive's Function Loss input provides a coast-to-rest operational stop. A coast-to-rest stop turns off the transistor power device drivers. A ramp-to-rest stop fires the transistor power device drivers until the motor comes to a stop, and then turns off the power devices.

In addition to the operational stop, the user must provide a hardwired emergency stop external to the drive. The emergency stop circuit must contain only hardwired electromechanical components. Operation of the emergency stop must not depend on electronic logic (hardware or software) or on the communication of commands over an electronic network or link.

2.8.1 Compliance with EN 60204-1: 1992

This section applies to users who must comply with EN 60204-1: 1992, part 9.2.5.4, Emergency Stop.

The SP100 coast-to-rest stop is a category 0 operational stop. The ramp-to-rest stop is a category 1 operational stop.

The required external hardwired emergency stop must be either a category 0 or 1 stop, depending on the user's risk assessment of the associated machinery. In order to fully comply with EN 60204-1: 1992, part 9.2.5.4, at least one of the system's stop methods must be a category 0 stop.

2.9 Wiring the Control Terminal Strip

The following sections describe how to wire the control signal I/O (Relay Output, Speed Reference, Function Loss, Forward / Reverse, Reset, and Start / Stop).

These connections are made to the control terminal strip, located at the bottom left of the drive, as shown in figure 2.2. The control terminal connections are listed and illustrated in figure 2.3.

The control terminal strip is isolated from the input power. Route the control wires separately from the power wires. Use 12-22 AWG wire for all control signals. The maximum lead length is 300 meters (1000 ft). Maximum torque is 7 in-lbs.

CONTROL TERMINAL STRIP

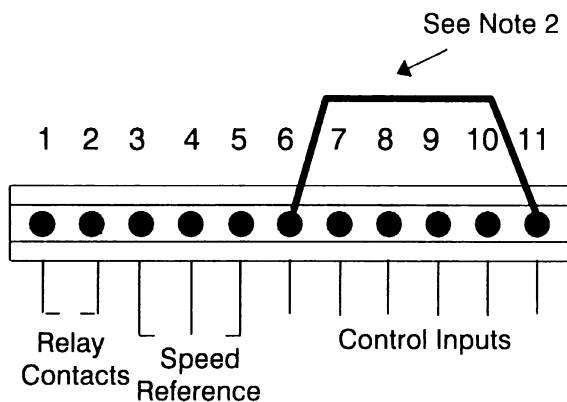

Terminal	Connection
1, 2	N.O. RELAY CONTACTS
3	INTERNAL 10 VOLT REFERENCE
4	SPEED REFERENCE INPUT
5	COMMON ⁽¹⁾
6	FUNCTION LOSS
7	FORWARD / REVERSE
8	RESET
9	START
10	STOP
11	COMMON ⁽¹⁾

(1) Terminals 5 and 11 (commons) are connected internally.

(2) A factory-installed jumper connected to terminals 6 and 11 must be removed when a function loss input, a coast-to-stop pushbutton, or other interlock is installed so that the contact will open to stop the drive.

Figure 2.3 - Control Terminal Strip

2.9.1 Relay Output

A normally open (N.O.) relay is provided at control terminals 1 and 2. The relay can be configured to indicate Drive Running (default) or Drive Fault (user option). Refer to section 3.5.3 for information on configuring the relay output.

2.9.2 Wiring the Speed Reference Signal Potentiometer

The motor speed reference signal can be provided by either a user supplied 5K potentiometer or by an external 0 to 10 VDC supply (see section 2.9.3). Control terminal 3 provides the 10 VDC reference for use with the potentiometer.

Perform the following procedure to wire the potentiometer as the speed reference (refer to figure 2.4):

- Step 1. Mount the speed reference potentiometer at an appropriate operator-accessible location, less than 300 meters (1000 ft) from the drive.
- Step 2. Connect one end of the potentiometer to control terminal 3 (+10V) and the other end to control terminal 5 (signal common).
- Step 3. Connect the potentiometer's wiper to control terminal 4 (speed reference input).

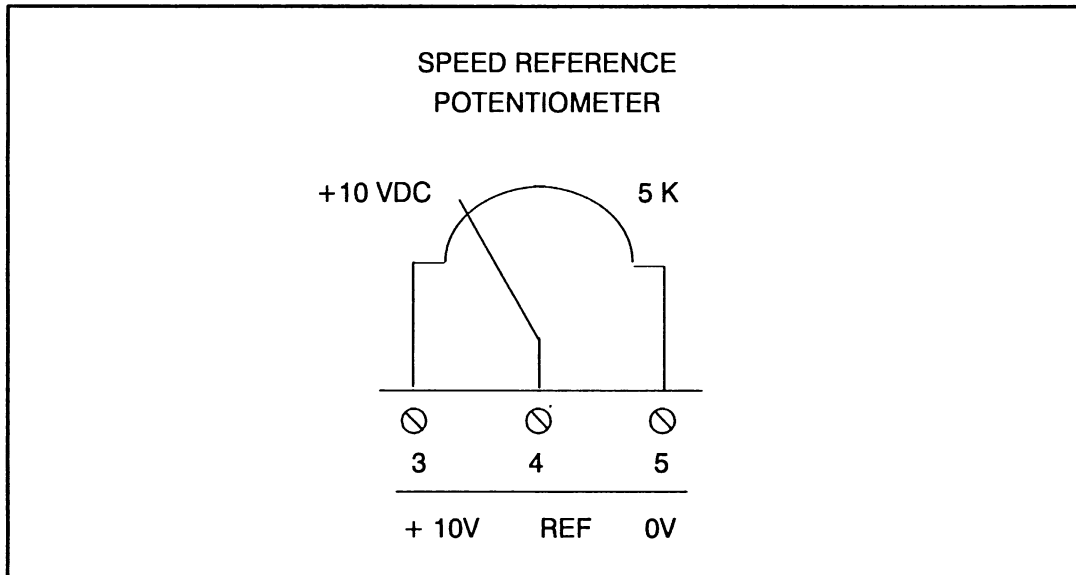

Figure 2.4 - Speed Reference Potentiometer Installation

2.9.3 Wiring an External 10 Volt Speed Reference

An external 0 to 10 VDC signal can be used instead of the potentiometer to set the speed reference. Connect the signal leads for the external speed reference to control terminals 4 and 5 as shown in figure 2.5. Control terminal 3 is not used with an external speed reference.

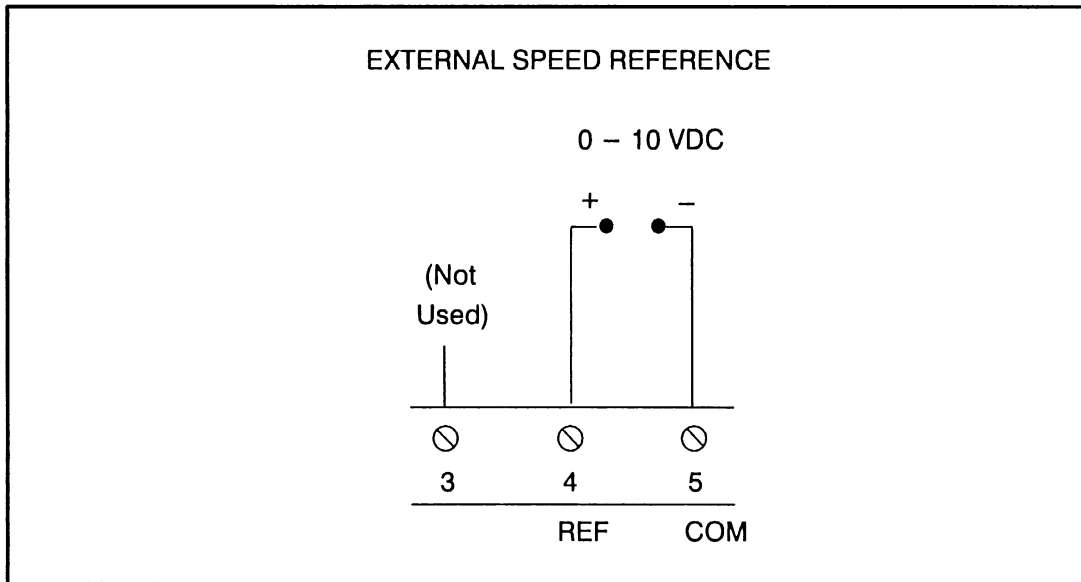

Figure 2.5 - External 10 VDC Speed Reference Wiring

2.9.4 Wiring Function Loss To Stop the Drive

A signal must be present at the Function Loss input (control terminal 6) for the drive to run. If the Function Loss signal is not present, the drive will turn off the power devices and coast-to-rest. The user must install a hardwired, operator-accessible pushbutton that provides a positive interrupt and shuts down the drive.

Function Loss overrides all other inputs. It can be used as a Run Permissive input or with safety interlocks as shown in figure 2.6

NOTE: Function Loss provides an operational stop. It does not fulfill the requirements of an emergency stop. Refer to section 2.8 for information regarding emergency stop requirements.

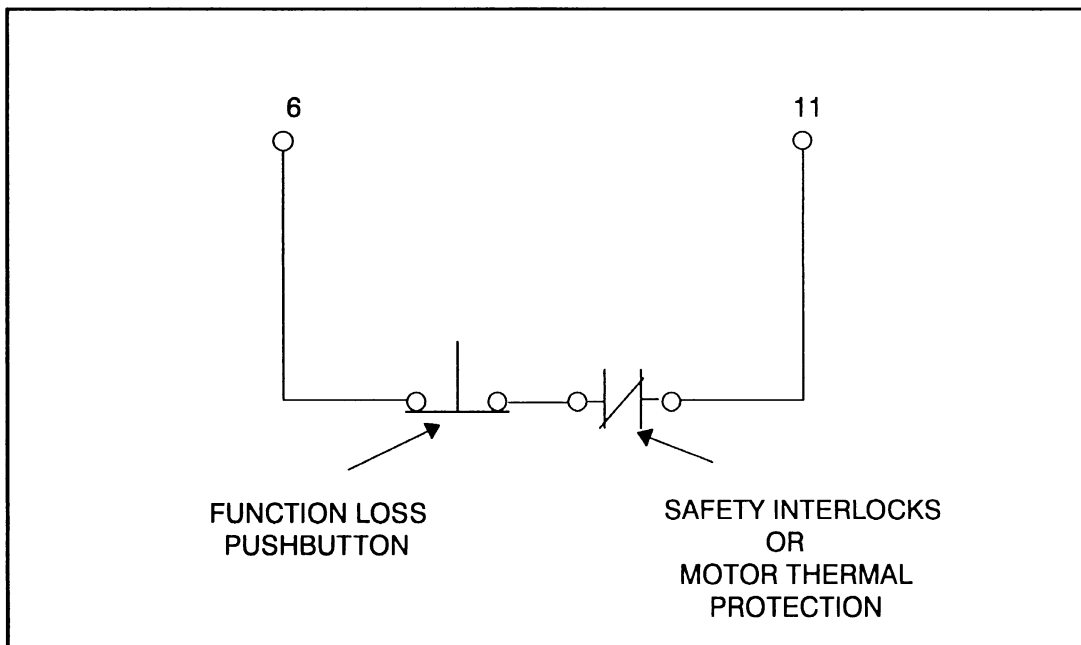

Figure 2.6 - Function Loss Control Wiring

2.9.5 Wiring Forward / Reverse Control

Forward / Reverse control wiring for the SP100 drive is shown in figure 2.7.

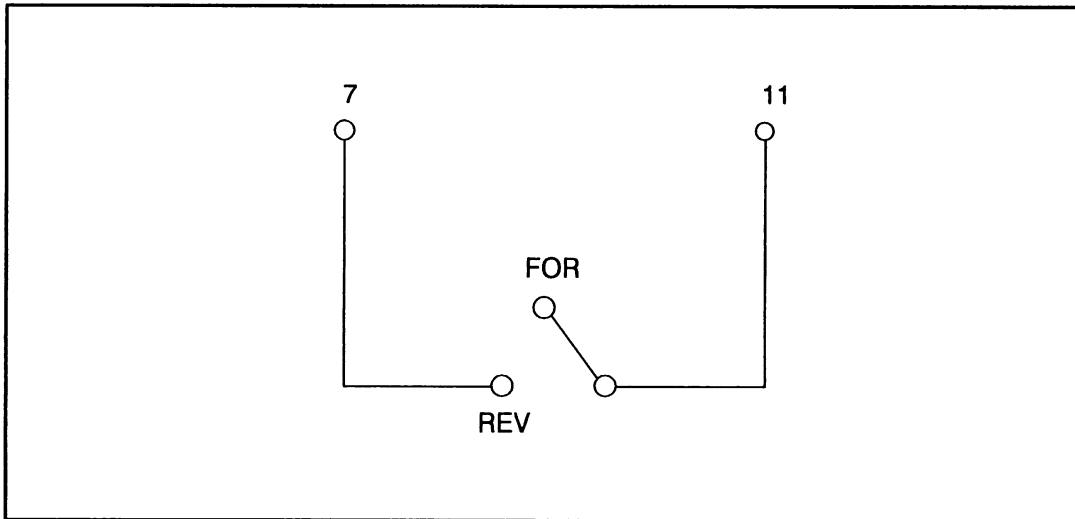

Figure 2.7 - Forward / Reverse Control Wiring

2.9.6 Wiring Reset Control

The Reset input (control terminal 8) is used to clear a fault that has caused the drive to shut down. Wire a N.O. pushbutton between control terminals 8 and 11, as shown in figure 2.8. Refer to Chapter 5, Diagnostics and Troubleshooting, for further information on handling drive faults.

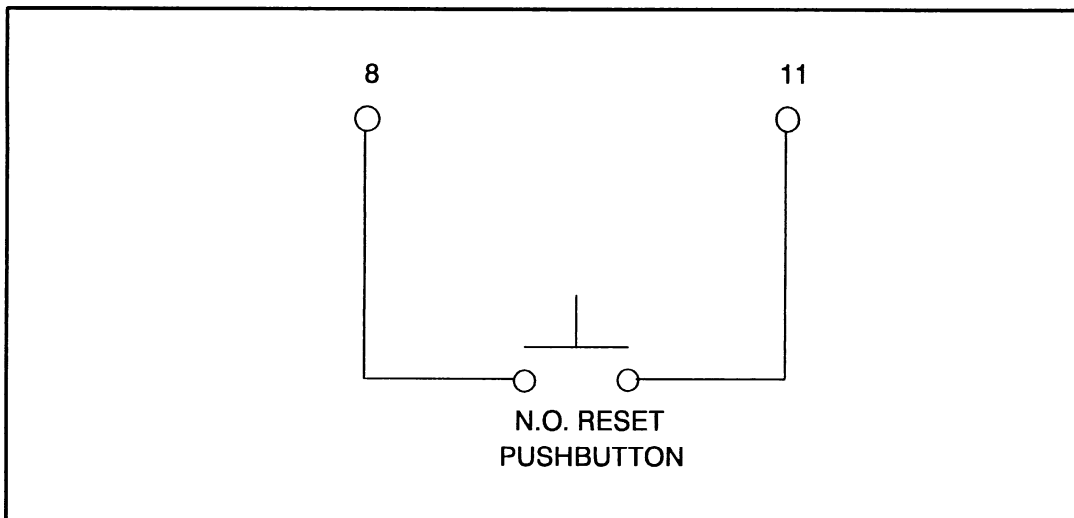

Figure 2.8 - Reset Control Wiring

2.9.7 Wiring Start / Stop Control

The system looks for a high-to-low transition at the Start input before starting the drive. If a maintained Start device is used and power to the drive is lost, the Start device must be opened and reclosed before the drive will start again.

Figure 2.9 illustrates wiring for a maintained 2-wire and for a momentary 3-wire Start/Stop control.

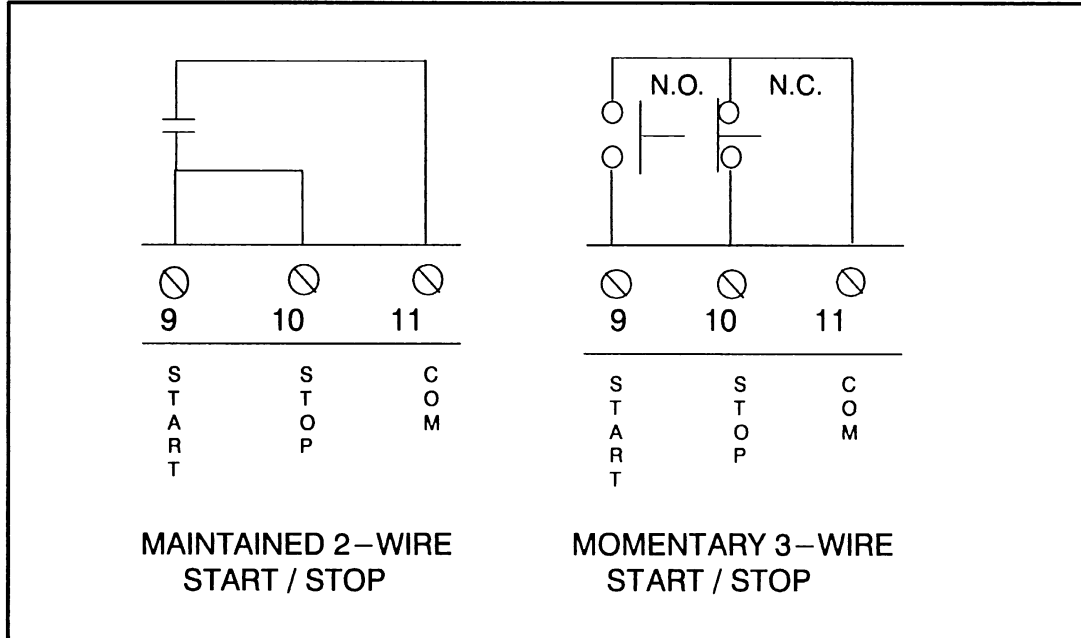

Figure 2.9 - Start / Stop Control Wiring

3.0 DRIVE CONFIGURATION

DANGER

ONLY QUALIFIED PERSONNEL FAMILIAR WITH THE CONSTRUCTION AND OPERATION OF THIS EQUIPMENT AND THE HAZARDS INVOLVED SHOULD INSTALL, ADJUST, OPERATE, AND/OR SERVICE THIS EQUIPMENT. READ AND UNDERSTAND THIS INSTRUCTION MANUAL IN ITS ENTIRETY BEFORE PROCEEDING. FAILURE TO OBSERVE THIS PRECAUTION COULD RESULT IN SEVERE BODILY INJURY OR LOSS OF LIFE.

DANGER

SETUP POTENTIOMETERS AND SWITCHES ARE AT LINE VOLTAGE WHEN POWER IS APPLIED TO THE DRIVE. ALL ADJUSTMENTS TO THESE COMPONENTS SHOULD BE MADE WITH POWER REMOVED. FAILURE TO OBSERVE THIS PRECAUTION COULD RESULT IN SEVERE BODILY INJURY OR LOSS OF LIFE.

DANGER

AFTER DISCONNECTING INPUT POWER WAIT FIVE MINUTES AND CHECK WITH A VOLTMETER TO INSURE THAT D-C BUS CAPACITORS ARE DISCHARGED. THE VOLTMETER SHOULD READ ZERO VOLTS. FAILURE TO OBSERVE THIS PRECAUTION COULD RESULT IN SEVERE BODILY INJURY OR LOSS OF LIFE.

The SP100 drive is configured using potentiometers and switches mounted on the printed circuit board. Normally, no adjustments will be needed to the factory settings. This chapter describes how to make adjustments to these settings, if required.

The default settings are listed in Appendix B. Any adjustments that are made to these settings by the user should be recorded in the appropriate column in Appendix B.

Review all configuration instructions thoroughly before making any adjustments or applying power to the drive.

The drive configuration potentiometers and switches described in the following sections are located in the lower right of the printed circuit board as shown in figure 2.2.

Before making any adjustments to the drive be sure to take the following precautions:

- Step 1. Turn off, lockout, and tag A-C input power to the drive.
- Step 2. Wait five minutes and verify with a voltmeter that the D-C bus capacitors are discharged. The voltmeter should read zero volts. See figure 2.2 for the D-C bus test points.

3.1 Adjusting the Maximum Speed

DANGER

THE USER IS RESPONSIBLE FOR ENSURING THAT DRIVEN MACHINERY AND ALL DRIVE-TRAIN MECHANISMS, ARE CAPABLE OF SAFE OPERATION AT THE MAXIMUM DRIVE FREQUENCY. FAILURE TO OBSERVE THIS PRECAUTION COULD RESULT IN SEVERE BODILY INJURY OR LOSS OF LIFE.

The maximum speed (MAXSPD) potentiometer sets the maximum output frequency of the drive. The operator speed reference setting will always be a value between the minimum output frequency setting (MINSPD) and this maximum value.

Range: 1/2 to 2 times the motor's base frequency (50 or 60 Hz)

Default: 60 Hz

To set the maximum speed:

- Step 1. To increase the maximum output frequency of the drive, turn the MAXSPD potentiometer CW.
-or-
To decrease the maximum output frequency of the drive, turn the MAXSPD potentiometer CCW.
- Step 2. Apply power and set the operator's speed reference signal (control terminal 4) to maximum (10 VDC).
- Step 3. Use a handheld tachometer to monitor motor speed.
- Step 4. Repeat the adjustment until the desired maximum speed is obtained.

3.2 Adjusting the Minimum Speed

DANGER

THE SP100 DRIVE IS INTENDED TO OPERATE THE MOTOR AT A PREDETERMINED MINIMUM SPEED. TO PREVENT INADVERTENT CONTACT WITH OPERATING EQUIPMENT, THE USER MUST VERIFY THAT THE MOTOR OUTPUT SHAFT WILL ROTATE AT ALL COMBINATIONS OF LOAD AND OUTPUT SPEED REQUIRED BY THE APPLICATION. FAILURE TO OBSERVE THIS PRECAUTION COULD RESULT IN SEVERE BODILY INJURY OR LOSS OF LIFE.

The minimum speed potentiometer (MINSPD) sets the minimum output frequency of the drive. The operator speed reference setting will always be a value between this minimum value and the maximum output frequency setting (MAXSPD).

Range: 3 Hz to 1/2 the motor's base frequency

Default: 3 Hz

To set the minimum speed:

- Step 1. To increase the minimum output frequency of the drive, turn the MINSPD potentiometer CW.
-or-
To decrease the minimum output frequency of the drive, turn the MINSPD potentiometer CCW.
- Step 2. Apply power and set the operator's speed reference signal (control terminal 4) to minimum (0 VDC).
- Step 3. Use a handheld tachometer to monitor motor speed
- Step 4. Repeat the adjustment until the desired minimum speed is obtained.

3.3 Adjusting the Acceleration / Deceleration Time

The acceleration time is the amount of time it takes the motor to ramp from stop to the maximum frequency setting of the drive (MAXSPD). The deceleration time is the amount of time it takes the motor to ramp from the maximum frequency setting to stop.

Note that if the operator speed reference setting is less than the maximum frequency value, the acceleration / deceleration ramp time will be proportionately less than the acceleration / deceleration setting.

Range: 1 to 100 seconds.

Default: 10 seconds.

To adjust the acceleration / deceleration (ACCDEC) time:

- Step 1. To increase the acceleration / deceleration time, turn the ACCDEC potentiometer CW.
-or-
To decrease the acceleration / deceleration time, turn the ACCDEC potentiometer CCW.
- Step 2. Apply A-C input power and test the operation of the drive.
- Step 3. Repeat the adjustment until the desired acceleration / deceleration time is obtained.

3.4 Adjusting Torque Boost

Torque boost (TRQBST) may be required to offset the voltage drop of the A-C motor at low speeds. For high inertia loads a high starting torque level may be needed. Torque boost is only effective at speeds lower than one-half the motor's base frequency.

Range: 0% to 10% of output voltage.

Default: 2%.

To adjust the torque boost:

- Step 1. To increase the torque boost, gradually turn the TRQBST potentiometer CW.
-or-
To decrease the torque boost, turn the potentiometer CCW.

- Step 2. Reapply A-C input power and test the operation of the drive.
- Step 3. Repeat the adjustment until the desired torque boost is obtained.

3.5 Drive Configuration Switches (SW1)

The drive configuration switches are located on DIP switch SW1, located near the bottom right of the printed circuit board as shown in figure 2.2.

The individual switches are numbered 1 through 8, from left to right, as shown in figure 3.1. The "ON" position is the factory setting, as described in the following sections. To change a factory setting, move the respective switch to the off position.

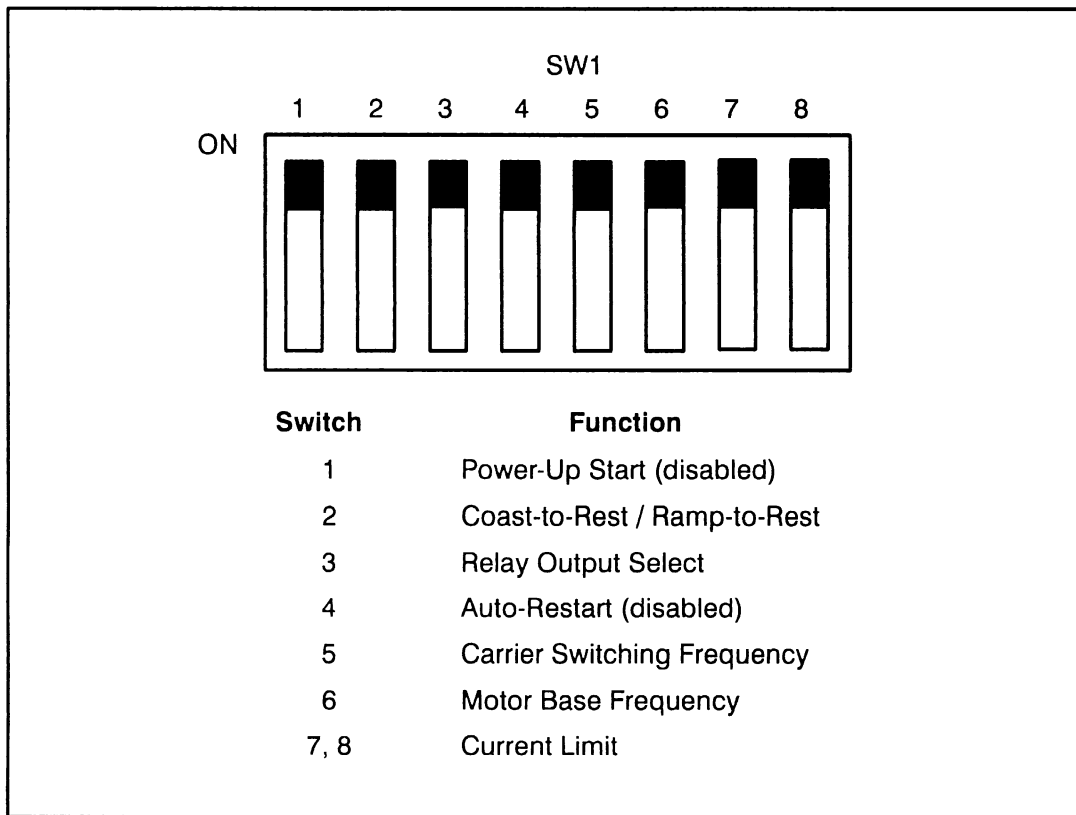

Figure 3.1 - Drive Configuration DIP Switch (SW1)

Observe the precautions of removing power and discharging the D-C bus as described previously in this chapter before making any adjustments.

3.5.1 Power-Up Start (SW1, Position 1)

DANGER

ENABLING THIS FUNCTION CAUSES THE MOTOR TO START AUTOMATICALLY ON POWER-UP. IF THE START INPUT IS MAINTAINED AND NO ACTIVE FAULTS ARE PRESENT, THE MOTOR WILL START WHEN POWER IS APPLIED TO THE DRIVE. THE USER MUST ENSURE THAT AUTOMATIC START-UP OF THE DRIVEN EQUIPMENT WILL NOT CAUSE INJURY TO OPERATING PERSONNEL OR DAMAGE TO THE DRIVEN EQUIPMENT. FAILURE TO OBSERVE THIS PRECAUTION COULD RESULT IN SEVERE BODILY INJURY OR LOSS OF LIFE.

The switch at position 1 on SW1 is factory set to disable the power-up start function. Enabling this function causes the motor to start automatically on power-up. If the start input is maintained and no active faults are present, the motor will start when power is applied to the drive. If A-C power is lost, the drive will restart without command when power is returned.

Under these circumstances, it is the responsibility of the user to ensure that a dangerous condition does not exist when a stop function is reset or lost A-C power returns.

Settings (SW1, Position 1):

ON = Power-Up Start Disabled (DEFAULT)

OFF = Power-Up Start Enabled

3.5.2 Coast-to-Rest/Ramp-to-Rest (SW1, Position 2)

The switch at position 2 on SW1 is used to configure the drive to either coast-to-rest or ramp-to-rest when the Stop input is asserted. A coast-to-rest stop turns off the power device drivers. A ramp-to-rest stop fires the power device drivers until the motor comes to a stop, and then turns off the power devices. The factory setting is coast-to-rest.

Settings (SW1, Position 2):

ON = Coast-to-Rest (DEFAULT)

OFF = Ramp-to-Rest

3.5.3 Relay Output Select (SW1, Position 3)

The switch at position 3 on SW1 is used to configure the N.O. Relay output (control terminals 1 and 2) to indicate Drive Running or Drive Fault. The factory setting is Drive Running.

Settings (SW1, Position 3):

ON = Drive Running Indication (DEFAULT)

OFF = Drive Fault Indication

3.5.4 Auto-Restart (SW1, Position 4)

DANGER

ENABLING THIS FUNCTION CAUSES THE DRIVE TO RESTART AUTOMATICALLY AFTER CERTAIN DRIVE FAULTS HAVE SHUT DOWN THE DRIVE. WHEN THIS FUNCTION IS ENABLED, THE USER MUST ENSURE THAT AUTOMATIC RESTART OF THE DRIVEN EQUIPMENT WILL NOT CAUSE INJURY TO OPERATING PERSONNEL OR DAMAGE TO THE DRIVEN EQUIPMENT. FAILURE TO OBSERVE THIS PRECAUTION COULD RESULT IN SEVERE BODILY INJURY OR LOSS OF LIFE.

The switch at position 4 on SW1 is factory set to disable the auto-restart function. If auto-restart is enabled, the drive will shut down as usual upon the detection of a fault, wait five seconds, and attempt restart automatically. If the fault reoccurs, the drive will again wait five seconds before trying to start, to a maximum of four attempts within a five minute period. If the drive fails all these attempts, it will remain in the faulted state.

Auto-restartable faults include:

- Overcurrent
- Electronic Thermal Overload
- High Bus Voltage
- Low Bus Voltage
- Power Module Overtemperature

Note that if the drive is counting down an auto-restartable fault, and the Reset input is asserted, the auto-restart will be canceled.

Settings (SW1, Position 4):

ON = Auto-Restart Disabled (DEFAULT)

OFF = Auto-Restart Enabled

3.5.5 Carrier Switching Frequency (SW1, Position 5)

The switch at position 5 on SW1 is used to set the carrier switching frequency to 4 KHz or 8 KHz. The factory setting is 8 KHz.

The carrier frequency controls the width of the output pulse and keeps the current smooth to the motor. It can be used to compensate for acoustic noise, heating, and other current problems by adjusting the switching frequency of the IGBTs in the power module.

The 8 KHz carrier frequency will alleviate acoustic noise. The 4 KHz carrier frequency will maximize the continuous power rating of the drive and will generally still result in an acceptable acoustic noise level from the motor.

Settings (SW1, Position 5):

ON = 8 KHz (DEFAULT)

OFF = 4 KHz

3.5.6 Motor Base Frequency (SW1, Position 6)

The switch at position 6 on SW1 sets the motor base frequency to 50 Hz or 60 Hz. The factory setting is 60 Hz.

Settings (SW1, Position 6):

ON = 60 Hz (DEFAULT)

OFF = 50 Hz

3.5.7 Current Limit (SW1, Positions 7 and 8)

The switches at positions 7 and 8 on SW1 are used to set the current limit to 50, 100, 125, or 150% of the selected motor panel rating (see section 3.6). The factory setting is 150%. Refer to table 3.1 for the switch positions.

Current limit provides the means to limit output torque while the motor is running or accelerating. When output current attempts to exceed the preset current limit, motor current is maintained or reduced, or the acceleration / deceleration time is extended. If current limit is set too low or too high relative to the required load, an overcurrent fault may occur.

Table 3.1 - Current Limit Settings

SW1, Position 7	SW1, Position 8	Current Limit
OFF	OFF	50%
OFF	ON	100%
ON	OFF	125%
ON	ON	150% (DEFAULT)

3.6 Motor Current Selection Switch (SW2)

The motor current selection switch (MOTOR AMPS) is located in the lower right corner of the printed circuit board as shown in figure 2.2. It is illustrated in figure 3.2. This switch is used to set the maximum full load current the motor will require. The default setting is 3.4 amps. If this does not match the motor nameplate rating, the correct setting should be selected from figure 3.2.

The overload trip level is 150% of selected motor amps for one minute.

MOTOR AMPS

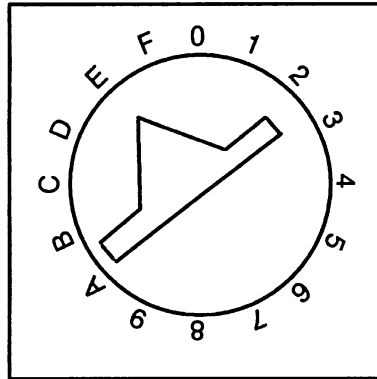

Position	FL Amps	Position	FL Amps
0	1.0	8	2.4
1	1.1	9	2.6
2	1.2	A	2.8
3	1.4	B	3.0
4	1.6	C	3.2
5	1.8	D	3.3
6	2.0	E	3.4 *
7	2.2	F	3.6

* Default Setting: 3.4 amps.

Figure 3.2 - Motor Current Selection Switch (SW2)

To adjust the setting, insert a small screwdriver into the slot and set the switch to one of the 16 positions as listed in figure 3.2.

4.0 INITIAL START-UP PROCEDURES

DANGER

ONLY QUALIFIED ELECTRICAL PERSONNEL, FAMILIAR WITH THE CONSTRUCTION AND OPERATION OF THIS EQUIPMENT AND THE HAZARDS INVOLVED, SHOULD INSTALL, ADJUST, OPERATE, AND/OR SERVICE THIS EQUIPMENT. READ AND UNDERSTAND THIS MANUAL IN ITS ENTIRETY BEFORE PROCEEDING. FAILURE TO OBSERVE THESE PRECAUTIONS COULD RESULT IN SEVERE BODILY INJURY OR LOSS OF LIFE.

To ensure safe operation, check the installation with the power off before operating the drive. When power is first applied, the direction of rotation, operator speed reference voltage, and operation under load should be tested.

4.1 Checking the Installation with the Power Off

DANGER

AFTER DISCONNECTING INPUT POWER WAIT FIVE MINUTES AND CHECK WITH A VOLTMETER TO INSURE THAT D-C BUS CAPACITORS ARE DISCHARGED. THE VOLTMETER SHOULD READ ZERO VOLTS. FAILURE TO OBSERVE THESE PRECAUTIONS COULD RESULT IN SEVERE BODILY INJURY OR LOSS OF LIFE.

Perform the following checks of the drive installation with the power off:

- Step 1. If an input disconnect is installed, make sure it is in the OFF position.
- Step 2. Wait five minutes after disconnecting power and verify that the D-C bus has discharged to zero volts. See figure 2.2 for the test points used to measure D-C bus voltage.
- Step 3. Check that any drive interlocks installed around the driven machine are operational.
- Step 4. Check that the recommended user-installed Function Loss pushbutton (see section 2.9.4) is operational.
- Step 5. Check that there is adequate clearance around the drive. Refer to figure 2.1.
- Step 6. Check that the wiring to the control terminal strip and to the power terminals is correct (figures 2.2 through 2.9)
- Step 7. Check that user-supplied branch circuit protection is properly installed and correctly rated.
- Step 8. Check that incoming A-C power is correctly rated.

- Step 9. Check the motor installation and the length of the motor leads.
- Step 10. Make sure there are no power correction capacitors connected to the motor.
- Step 11. Check that the motor thermal switch (if available) is set.
- Step 12. Check that the rating of the transformer (if used) matches the drive requirements, and that the transformer is connected for the proper voltage.
- Step 13. Check that a properly sized ground wire is installed and that a suitable earth ground is used. Verify that all ground leads are run unbroken.
- Step 14. Check for and eliminate any grounds between the motor frame and the motor power leads.

4.2 Checking the Direction of Rotation

DANGER

THE FOLLOWING PROCEDURES REQUIRE ROTATING PARTS AND/OR ELECTRICAL CIRCUITS TO BE EXPOSED. STAY CLEAR IF THE UNIT MUST BE RUNNING. DISCONNECT, LOCKOUT, AND TAG THE POWER SOURCE IF CONTACT MUST BE MADE. FAILURE TO OBSERVE THESE PRECAUTIONS COULD RESULT IN SEVERE BODILY INJURY OR LOSS OF LIFE.

After verifying that the drive installation is correct, check the direction of rotation of the motor using the following procedure:

- Step 1. Uncouple the driven equipment from the motor, if possible.
- Step 2. Set the operator speed reference signal to zero volts (minimum speed).
- Step 3. Turn power on to the drive.
- Step 4. Press the user-installed Start button (section 2.9.7).
- Step 5. Visually check the direction of shaft rotation. If shaft rotation is correct, proceed to the next section, Checking the Speed Reference Voltage. If shaft rotation is incorrect, continue to step 6.
- Step 6. If shaft rotation is incorrect:
 - a. Stop the drive. Wait for the motor to come to a complete stop.
 - b. Remove power and verify that the D-C bus has discharged.
 - c. Reverse any two of the three motor power leads (U/T1, V/T2, or W/T3).
 - d. Repeat the direction of rotation check beginning with step 2.

4.3 Checking the Speed Reference Voltage

Use the following procedure to check the speed reference voltage:

- Step 1. Vary the operator speed reference voltage and run the motor unloaded across the speed range. Use a handheld tachometer to check the speed.
- Step 2. If the motor operates satisfactorily, proceed to the next section, Testing the Drive Under Load.
If the motor does not operate satisfactorily, continue with step 3:
- Step 3. If the motor does not operate satisfactorily:
 - a. Check that the speed reference potentiometer or external speed reference is wired correctly, and that the speed reference input (control terminal 4) can be varied from 0 to 10 VDC.
 - b. If the speed reference is correct, and the motor does not operate satisfactorily, refer to chapter 3, Drive Configuration.

4.4 Testing the Drive Under Load

Use the following procedure to test the drive under load:

- Step 1. Turn off, lockout, and tag power to the drive. Wait five minutes and verify that the D-C bus has discharged to zero volts.
- Step 2. Couple the driven equipment to the motor.
- Step 3. Turn power on and start the drive.
- Step 4. Run the drive across the required speed range under load.
If the motor does not rotate at minimum speed, increase the torque boost (see section 3.4).
- Step 5. If the drive operates the motor properly:
 - a. Turn off, lockout, and tag power to the drive.
 - b. Verify that the D-C bus has discharged to zero volts.
 - c. Secure the cover of the protective enclosure.
 - d. Record any changes made to component settings in Appendix B.
- Step 6. If the drive does not operate the motor properly:
 - a. Refer to chapter 5, Diagnostics and Troubleshooting.
 - b. Verify the configuration settings again.

5.0 DIAGNOSTICS AND TROUBLESHOOTING

DANGER

ONLY QUALIFIED ELECTRICAL PERSONNEL, FAMILIAR WITH THE CONSTRUCTION AND OPERATION OF THIS EQUIPMENT AND THE HAZARDS INVOLVED, SHOULD INSTALL, ADJUST, OPERATE, AND/OR SERVICE THIS EQUIPMENT. READ AND UNDERSTAND THIS INSTRUCTION MANUAL IN ITS ENTIRETY BEFORE PROCEEDING. FAILURE TO OBSERVE THIS PRECAUTION COULD RESULT IN SEVERE BODILY INJURY OR LOSS OF LIFE.

The SP100 drive is monitored by internal diagnostics. The drive status is indicated by an LED, as described in section 5.1. Refer to section 5.2 for aid in identifying and correcting internal drive faults.

For aid in troubleshooting drive problems not detected by the internal diagnostics, refer to section 5.3.

5.1 Status LED

The status LED is located in the lower right center of the printed circuit board, as shown in figure 2.2. When power is applied, the LED will turn on and remain on continuously while the drive is running properly.

If a fault occurs, the drive will coast-to-rest, and the LED will blink a specific number of times to identify the fault. The blinking is followed by a pause, and then repeated. For example, an overcurrent fault is indicated by a pattern of two blinks, a pause, two blinks, etc. This continues until the fault is corrected and the drive is reset.

If another fault is present, it will be indicated by the LED after the drive is reset.

The drive faults that are user-correctable are described in section 5.2. **All other faults are fatal and require replacement of the drive.** Fatal faults are indicated by the LED repeatedly blinking eight or more times in succession.

Table 5.1 - LED Status Indications

Condition	Indication
Steady ON	Normal operation.
Steady OFF	No power.
Blinking: 1 to 7 times	User-correctable drive fault. See table 5.2.
Blinking: 8 or more times	Fatal error. Drive must be replaced.

5.2 Internal Diagnostics

The following table describes the drive faults that may be correctable by the user. The corrective action assumes that a Reset pushbutton has been wired between control terminals 8 and 11, as described in section 2.9.6.

If the recommended corrective action fails to clear the fault, the drive must be replaced.

Table 5.2 - Drive Faults

LED Indication: 1 blink, repeating continuously	
Fault: Function Loss	
Cause:	Corrective Action:
The Function Loss command has been asserted (control terminals 6 and 11).	Reset the drive. The error will not clear until the Function Loss command is unasserted.
LED Indication: 2 blinks, repeating continuously	
Fault: Overcurrent	
Cause:	Corrective Action:
1. A short in the drive outputs.	1. Check that the input and output wiring to the drive is properly connected.
2. A ground fault.	2a. Check that the input and output wiring to the drive is properly connected. 2b. Check that an output phase is not shorted to ground or to any other voltage source.
3. An instantaneous overcurrent resulting in greater than 200% rated drive current.	3a. Increase the acceleration / deceleration time. (see section 3.3) 3b. Adjust the current limit level, if it is too low or too high, relative to the load. (see section 3.5.7) 3c. Lower the torque boost setting. (see section 3.4)
	Reset the drive.
LED Indication: 3 blinks, repeating continuously	
Fault: Electronic Thermal Overload	
Cause:	Corrective Action:
Excessive motor current. The overload trip level is 150% of selected motor amps (SW2) for 1 minute.	Verify the MOTOR AMPS switch matches the amps rating of the motor. Reset the drive.

LED Indication: 4 blinks, repeating continuously	
Fault: High Bus Voltage	
Cause: The D-C bus charged above the high bus threshold level.	Corrective Action: a. Increase the acceleration / deceleration time to make the deceleration longer (see section 3.3). b. Reduce an overhauling load. Reset the drive. The error will not clear until the bus voltage falls below the high bus level.
LED Indication: 5 blinks, repeating continuously	
Fault: Low Bus Voltage	
Cause: The D-C bus has fallen below the electronic trip threshold level.	Corrective Action: Reset the drive. The error will not clear until the input line voltage is within the proper range.
LED Indication: 6 blinks, repeating continuously	
Fault: Ground Fault	
Cause: An output phase is shorted to earth ground.	Corrective Action: a. Check that an output phase is not shorted to ground or to any other voltage source. b. Check that an output phase is not connected in error to one of the D-C bus terminal points. Reset the Drive.
LED Indication: 7 blinks, repeating continuously	
Fault: Power Module Over Temperature	
Cause: The internal thermostat has caused a trip due to excessive temperature in the drive's power module.	Corrective Action: Check the ambient operating conditions. Reset the drive. The error will not clear until the internal drive temperature is back within range.

5.3 Troubleshooting Guidelines

If the internal diagnostics fail to identify the cause of a problem, review table 5.3 before performing any troubleshooting. If the problem cannot be resolved by the recommended corrective actions in tables 5.2 and 5.3, the drive must be replaced.



AFTER DISCONNECTING INPUT POWER WAIT FIVE MINUTES AND CHECK WITH A VOLTMETER TO INSURE THAT D-C BUS CAPACITORS ARE DISCHARGED. THE VOLTMETER SHOULD READ ZERO VOLTS. FAILURE TO OBSERVE THESE PRECAUTIONS COULD RESULT IN SEVERE BODILY INJURY OR LOSS OF LIFE.

Observe the following precautions when troubleshooting the drive:

- Stop the drive using either the Stop input or Function Loss.
- Disconnect, tag, and lockout A-C power before working on the drive.
- Verify that there is no voltage present at A-C input terminals R/L1 and S/L2. (Refer to figure 2.2)
- Wait five minutes and verify that the D-C bus has discharged to zero volts. See figure 2.2 for the location of the D-C bus test points.

Table 5.3 - Troubleshooting

Indication: Incoming line fuse blows when power is applied to the drive.	
Possible Cause:	Corrective Action:
1. Faulty incoming A-C line wiring or an inadvertent ground in the branch circuit.	1. Check all incoming A-C wires and terminations to the drive. Correct any faulty wiring and remove any unintentional grounds. Replace the blown fuse.
Indication: Incoming line fuse blows when the drive starts.	
Possible Cause:	Corrective Action:
1. Motor stator shorted or grounded.	1. Repair or replace the motor. Replace the blown fuse.
2. Loose or corroded connection, faulty or incorrect wiring.	2. Check that all connections and wiring between the line, drive, and motor are correct. Replace the blown fuse.
3. Sudden, severe application of overload to the motor.	3. Investigate driven equipment for possible cause and correct. Replace the blown fuse.

Indication: Motor does not rotate.

Possible Cause:

1. Faulty or incorrect wiring.
2. Incoming line fuse blown and/or upstream protection devices open.
3. Faulty speed reference signal.
4. Drive current output set lower than applied motor horsepower.

Corrective Action:

1. Check all external wires and termination at the drive. Check all wiring within the motor conduit box. Correct any faulty wiring.
2. Investigate upstream equipment for possible cause and correct. Replace the blown fuse.
3. Check wiring and operation of speed reference potentiometer or external 10 VDC reference.
4. Recheck and reset as necessary.

Indication: Motor does not reach top speed or deliver rated torque.

Possible Cause:

1. Low line voltage.
2. Overload.
3. Drive current output set lower than applied motor horsepower.

Corrective Action:

1. Check for rated line voltage and correct if not within 10% of the input voltage rating.
2. Check for cause of overload and correct.
3. Recheck and reset as necessary.

Appendix A

Technical Specifications

Model Number: 1AU2001

Input Ratings

- A-C line voltage: 115 VAC or 200-230 VAC, +/- 10%
- A-C line frequency: 48 to 62 Hz
- A-C line current: 9.0 A
- Maximum symmetrical RMS fault current: 5,000 A
- Maximum A-C line distribution: 115 VAC, single-phase: 25 KVA
230 VAC, single-phase: 50 KVA

Output Ratings

- Horsepower: 1 HP at 230 VAC
- Output voltage: 115 VAC, 3-phase / 230 VAC, 3-phase
- Maximum continuous output current: 3.6 A
- Maximum output current: 5.4 A (150% of rated, 1 minute overload)
- Output frequency: 3 to 120 Hz
- Output carrier frequency: 4 KHz or 8 KHz

Control Inputs

- Rated voltage: 24 VDC
- Rated current: 6 mA, sinking (input terminal to common)
- Maximum off-state leakage current: 1 mA

Speed Reference Input

- Internal impedance: 50 K ohms

Relay Output

- Rated current and voltage: 1 A maximum at 265 VAC

Operating Performance

- Speed regulation: 0 to 5% (Motor dependent)
- Speed range: 40:1 (3 to 120 Hz)
- Power dip ride through time: 500 msec minimum

Drive Power Loss

- Typical full load power loss: 60 W

Ambient Conditions

- Operating temperature: 0 to 55°C (32°F to 131°F)
- Heatsink temperature (maximum): 110°C (230°F)
- Storage temperature: –40°C to 65°C (–40°F to 149°F)
- Humidity: 5 to 95% non-condensing
- Elevation: 1000 meters (3300 ft) maximum without derating.
For every 91.4 meters (300 ft) above 1000 meters, derate the current by 1%. Above 3000 meters (10,000 ft) consult your Reliance Sales Office.

Dimensions

- Height: 155.4 mm (6.12 inches)
- Width: 140.0 mm (5.50 inches)
- Depth: 108.2 mm (4.26 inches)

Appendix B

Component Settings

Component	Range	Default Setting	User Data	
			Date	Setting
MAXSPD	1/2 to 2X motor base speed	60 Hz		
MINSPPD	3 Hz to motor base speed	3 Hz		
TRQBST	0% to 10% of output voltage	2%		
ACCDEC	1 to 100 seconds	10 secs		
SW1, Pos. 1 Power-Up Start	Enable / Disable	Disable		
SW1, Pos. 2	Coast-to-Rest / Ramp-to-Rest	Coast-to-Rest		
SW1, Pos. 3	Drive Running / Drive Fault Indication	Drive Running		
SW1, Pos. 4 Auto-Restart	Enable / Disable	Disable		
SW1, Pos. 5 Carrier Frequency	4 KHz, 8 KHz	8 KHz		
SW1, Pos. 6 Base Frequency	50 Hz, 60 Hz	60 Hz		
SW1, Pos. 7 & 8 Current Limit	50, 100, 125, or 150% of rated current	150%		
SW2 Motor Amps	1.0 A to 3.6 A.	3.4 A		

A

ACCDEC. See acceleration / deceleration time
Acceleration / Deceleration time, 3-3
Auto-restart, 3-6

B

Branch circuit protection, 2-4

C

Carrier switching frequency, 3-6
Component locations, 2-6
Component settings, B-1
Configuring The Drive See Drive Configuration
Control terminal strip, 2-9
Current limit, 3-7

D

Description, general, 1-1
Diagnostics and troubleshooting, 5-1 to 5-5
 troubleshooting guidelines, 5-4
 troubleshooting table, 5-4, 5-5
 internal diagnostics, 5-2, 5-3
 LED status indications, 5-1
Drive configuration, 3-1
 acceleration/deceleration time adjustment, 3-3
 auto-restart, 3-6
 carrier switching frequency, 3-6
 coast-to-rest/ramp-to-rest, 3-5
 current limit, 3-7
 DIP switch (SW1), 3-4
 maximum speed adjustment, 3-2
 minimum speed adjustment, 3-2, 3-3
 motor base frequency, 3-7
 motor current selection, 3-7, 3-8
 power-up start, 3-5
 relay output select, 3-5
 torque boost adjustment, 3-3, 3-4

E

Emergency stop, 2-8
EN 60204-1 compliance, 2-8

F

Faults. See Diagnostics and troubleshooting
Features, standard, 1-1, 1-2
Forward / Reverse, 1-2
 control wiring, 2-12
Function Loss, 1-2, 2-11

G

Grounding. See installation

I

Input Disconnect, 2-4
Installation, 2-1 to 2-13
 branch circuit protection, 2-4
 checking with power off, 4-1, 4-2
 drive, mounting, 2-1, 2-2
 drive mounting dimensions, 2-3
 emergency stop, 2-8
 grounding drive and motor, 2-7
 input disconnect, 2-4,
 isolation transformers, 2-4, 2-5
 motor. See motor
Isolation transformers, See installation

L

LED, 5-1

M

Maximum speed, 3-2
MAXSPD. See maximum speed
Minimum speed, 3-2, 3-3
MINSPD. See minimum speed

Motor

 base frequency, 3-7
 checking direction of rotation, 4-2
 grounding, 2-7
 installation, 2-7

O

Operating the drive, 1-2

P

Potentiometer
 adjusting, 4-3
 wiring, 2-9, 2-10
Power-up start, 3-5

R

Ratings
 branch circuit protection, 2-4
 current and voltage, 1-1
Relay output, 2-9, 3-5
Reset, 1-2, 2-12
 control wiring, 2-12

S

Specifications, technical, A-1, A-2
Speed Reference, 1-2
 checking, 4-3
 external 10 volt , 2-10, 2-11
 potentiometer, 2-9, 2-10
Start-up procedures, initial, 4-1 to 4-3
Start/Stop, 2-13
Starting the drive, 1-2
Stopping the drive, 1-2
 coast-to-rest/ramp-to-rest, 3-5
Switch
 drive configuration (SW1), 3-4
 motor current selection (SW2), 3-7, 3-8

T

Testing drive under load, 4-3
Torque boost, 3-3, 3-4
Troubleshooting. See diagnostics and troubleshooting
TRQBST. See torque boost

W

Wiring, 2-4 to 2-13
 A-C power, 2-5
 external 10 volt speed reference, 2-10, 2-11
 forward/reverse control, 2-12
 function Loss, 2-11
 reset control, 2-12
 start/stop control, 2-13
 signal and control, 2-8 to 2-13
 speed reference potentiometer, 2-9, 2-10

Reliance Electric / 24703 Euclid Avenue / Cleveland, Ohio 44117 / 216-266-7000

 **Rockwell** Automation
Reliance Electric