



**MD60 AC Drive  
User Manual  
Version 3.0**

---

Instruction Manual D2-3499-3

---

**Rockwell**  
**Automation**

The information in this manual is subject to change without notice.

Throughout this manual, the following notes are used to alert you to safety considerations:



**ATTENTION:** Identifies information about practices or circumstances that can lead to personal injury or death, property damage, or economic loss.

**Important:** Identifies information that is critical for successful application and understanding of the product.



**ATTENTION:** Only qualified personnel familiar with the construction and operation of this equipment and the hazards involved should install, adjust, operate, or service this equipment. Read and understand this document in its entirety before proceeding. Failure to observe this precaution could result in severe bodily injury or loss of life.

**ATTENTION:** The drive contains high voltage capacitors that take time to discharge after removal of mains supply. Before working on the drive, ensure isolation of mains supply from line inputs [R, S, T (L1, L2, L3)]. Wait three (3) minutes for capacitors to discharge to safe voltage levels. Darkened display LEDs is not an indication that capacitors have discharged to safe voltage levels. Failure to observe this precaution could result in severe bodily injury or loss of life.

**ATTENTION:** The drive can operate at and maintain zero speed. The user is responsible for assuring safe conditions for operating personnel by providing suitable guards, audible or visual alarms, or other devices to indicate that the drive is operating, or may operate, at or near zero speed. Failure to observe this precaution could result in severe bodily injury or loss of life.

**ATTENTION:** The drive contains ESD- (Electrostatic Discharge) sensitive parts and assemblies. Static control precautions are required when installing, testing, servicing, or repairing the drive. Erratic machine operation and damage to, or destruction of, equipment can result if this procedure is not followed. Failure to observe this precaution can result in bodily injury.

**ATTENTION:** The user must provide an external, hardwired emergency stop circuit outside of the drive circuitry. This circuitry must disable the system in case of improper operation. Uncontrolled machine operation may result if this procedure is not followed. Failure to observe this precaution could result in bodily injury.

**ATTENTION:** The user is responsible for conforming with all applicable local and national codes. Failure to observe this precaution could result in damage to, or destruction of, the equipment.

**ATTENTION:** An incorrectly applied or installed drive can result in component damage or reduction in product life. Wiring or application errors, such as undersizing the motor, incorrect or inadequate AC supply, or excessive ambient temperatures may result in malfunction of the system.

MD60, VS Utilities, and Reliance are trademarks of Rockwell Automation.

# CONTENTS

---

<b>Chapter 1 Introduction</b>	
1.1 Getting Assistance from Reliance Electric.....	1-1
<b>Chapter 2 About the MD60 Drive</b>	
2.1 Identifying the Drive by Model Number.....	2-1
2.2 MD60 Drive Ratings, Model Numbers, and Frame Sizes .....	2-2
2.3 Kits.....	2-3
2.4 Storage Guidelines .....	2-4
<b>Chapter 3 Mounting the Drive</b>	
3.1 General Requirements for the Installation Site .....	3-1
3.1.1 Operating Conditions.....	3-2
3.1.2 Recommended Mounting Clearances .....	3-2
3.1.3 Mounting Dimensions for the MD60 Drive.....	3-3
3.2 Mounting the Drive.....	3-4
3.2.1 Protecting the Drive from Debris .....	3-4
<b>Chapter 4 Grounding the Drive</b>	
4.1 RFI Filter Grounding .....	4-2
<b>Chapter 5 Installing Power Wiring</b>	
5.1 Opening the Cover.....	5-1
5.2 Verifying Drive AC Input Ratings Match Available Power .....	5-2
5.2.1 Ungrounded Distribution Systems .....	5-2
5.2.2 Input Power Conditioning .....	5-4
5.3 Power Wiring Specifications .....	5-5
5.4 Power Terminal Block Connections.....	5-5
5.5 Fuses and Circuit Breakers .....	5-6
5.6 Motor Cable Types Acceptable for 200-600 Volt Installations .....	5-8
5.7 Reflected Wave Protection .....	5-9
5.8 Output Disconnect .....	5-10
<b>Chapter 6 Installing Control Wiring</b>	
6.1 Stop Circuit Requirements.....	6-1
6.1.1 Compliance with Machinery Safety Standard EN 60204-1:1992 .....	6-2
6.2 Motor Start/Stop Precautions.....	6-2
6.3 I/O Wiring Recommendations.....	6-3
6.3.1 Maximum Cable Length Recommendations.....	6-3
6.4 Wiring the Control Terminal Block .....	6-4
6.4.1 I/O Wiring Examples.....	6-5

6.4.2	Typical Multiple Drive Connection Examples.....	6-7
6.5	Start and Speed Reference Control.....	6-8
6.6	Accel/Decel Selection .....	6-9
<b>Chapter 7</b>	<b>Completing the Installation</b>	
7.1	Checking the Installation Before Applying Power to the Drive .....	7-1
7.2	Powering Up After Installation is Complete.....	7-2
<b>Chapter 8</b>	<b>Using the Integral Keypad to Program and Control the Drive</b>	
8.1	Keypad Components .....	8-1
8.1.1	Display Description .....	8-2
8.1.2	LED Descriptions .....	8-2
8.1.3	Key Descriptions.....	8-3
8.2	About Parameters .....	8-4
8.3	How Parameters are Organized .....	8-4
8.4	Viewing and Adjusting Basic (P) and Advanced (A) Parameters .....	8-5
8.5	Viewing the Display (d) Parameters.....	8-6
<b>Chapter 9</b>	<b>Parameter Descriptions</b>	
9.1	Basic Program Group Parameters.....	9-2
9.2	Advanced Group Parameters .....	9-8
9.3	Display Group Parameters.....	9-27
<b>Chapter 10</b>	<b>Troubleshooting the Drive</b>	
10.1	Fault Codes.....	10-1
10.1.1	Manually Clearing Faults .....	10-2
10.1.2	Automatically Clearing Faults (Auto Restart Feature).....	10-2
10.2	Troubleshooting Tables .....	10-6
10.2.1	Problem: Drive Does Not Start From Terminal Block Start or Run Inputs .....	10-6
10.2.2	Problem: Drive Does Not Start From Integral Keypad .....	10-7
10.2.3	Problem: Drive Does Not Respond to Changes in Speed Command .....	10-7
10.2.4	Problem: Motor and/or Drive Will Not Accelerate to Commanded Speed .....	10-8
10.2.5	Problem: Motor Operation is Unstable.....	10-8
10.2.6	Problem: Drive Will Not Reverse Motor Direction .....	10-9
<b>Appendix A</b>	<b>Technical Specifications .....</b>	<b>A-1</b>
<b>Appendix B</b>	<b>Record of User Settings .....</b>	<b>B-1</b>
<b>Appendix C</b>	<b>Parameters Cross-Referenced by Name .....</b>	<b>C-1</b>

<b>Appendix D</b>	CE Conformance Requirements .....	D-1
<b>Appendix E</b>	Accessories .....	E-1
<b>Appendix F</b>	RS485 (MDI) Protocol.....	F-1
<b>Appendix G</b>	RJ45 Splitter Cable .....	G-1
<b>Index</b>	.....	Index-1



# List of Figures

Figure 2.1 – Identifying the Drive by Model Number.....	2-1
Figure 3.1 – Minimum Mounting Clearances .....	3-2
Figure 3.2 – Drive Dimensions - Front View .....	3-3
Figure 3.3 – Drive Dimensions - Bottom View .....	3-3
Figure 4.1 – Typical Grounding.....	4-1
Figure 5.1 – Opening the Cover.....	5-1
Figure 5.2 – Removing the Finger Guard .....	5-2
Figure 5.3 – Jumper Location (A Frame Shown) .....	5-3
Figure 5.4 – Phase-to-Ground MOV Removal.....	5-3
Figure 5.5 – Power Terminal Block Connections.....	5-5
Figure 6.1 – Wiring the Control Terminal Block .....	6-4
Figure 6.2 – I/O Wiring Examples .....	6-5
Figure 6.3 – Override Priority for the Speed Reference Command .....	6-8
Figure 6.4 – Accel/Decel Selection .....	6-9
Figure 8.1 – Integral Keypad .....	8-1
Figure 9.1 – Accel Time 1 (P039) .....	9-7
Figure 9.2 – Decel Time 1 (P040).....	9-7
Figure 9.3 – Accel Time 2 (A067) .....	9-11
Figure 9.4 – Decel Time 2 (A068).....	9-12
Figure 9.5 – DC Brake Level (A081).....	9-14
Figure 9.6 – S Curve% (A083) Examples .....	9-15
Figure 9.7 – Start Boost (A084) .....	9-16
Figure 9.8 – Motor OL Select (A090) .....	9-17
Figure 9.9 – Derating Guidelines Based on PWM Frequency (A091) Selection .....	9-18
Figure 9.10 – Drive Status (d006) Bit Definitions.....	9-28
Figure 9.11 – Control Source (d012) Bit Definitions .....	9-29
Figure 9.12 – Control Input Status (d013) Bit Definitions.....	9-30
Figure 9.13 – Digital Input Status (d014) Bit Definitions .....	9-30
Figure 9.14 – Comm Status (d015) Bit Definitions.....	9-31



# List of Tables

Table 2.1 – Drive Ratings, Model Numbers, and Frame Sizes.....	2-2
Table 2.2 – Standard Kits .....	2-3
Table 3.1 – Ambient Operating Temperatures and Mounting Clearances.	3-2
Table 3.2 – Mounting Specifications.....	3-4
Table 5.1 – Corrective Actions for Input Power Conditions .....	5-4
Table 5.2 – Power Wiring Specifications .....	5-5
Table 5.3 – Power Terminal Block Specifications.....	5-5
Table 5.4 – Drive, Fuse, and Circuit Breaker Ratings.....	5-7
Table 5.5 – Shielded Motor Cable Types Acceptable for 200-600 Volt Installations .....	5-8
Table 5.6 – Maximum Cable Length Recommendation.....	5-9
Table 6.1 – Recommended Control and Signal Wire.....	6-3
Table 6.2 – I/O Terminal Block Specifications .....	6-3
Table 6.3 – Typical Multiple Drive Connection Examples.....	6-7
Table 8.1 – LED Descriptions .....	8-2
Table 8.2 – Key Descriptions .....	8-3
Table 8.3 – Viewing and Adjusting Basic (P) and Advanced (A) Parameters .....	8-5
Table 8.4 – Viewing the Display (d) Parameters.....	8-6
Table 9.1 – Trip Points for Digital Output Relay.....	9-11
Table 9.2 – Selecting the Reference Source Using Presets.....	9-13
Table 10.1 – Fault Descriptions and Corrective Actions .....	10-3
Table 10.2 – Problem: Drive Does Not Start From Terminal Block Start or Run Inputs .....	10-6
Table 10.3 – Problem: Drive Does Not Start From Integral Keypad .....	10-7
Table 10.4 – Problem: Drive Does Not Respond to Changes in Speed Command .....	10-7
Table 10.5 – Problem: Motor and/or Drive Will Not Accelerate to Commanded Speed.....	10-8
Table 10.6 – Problem: Motor Operation is Unstable.....	10-8
Table 10.7 – Problem: Drive Will Not Reverse Motor Direction .....	10-9



# CHAPTER 1

---

## Introduction

This manual is intended for qualified electrical personnel familiar with installing, programming, and maintaining AC drives.

This manual contains information on:

- Installing and wiring the MD60 drive
- Programming the drive
- Troubleshooting the drive

The latest version of this manual is available from <http://www.theautomationbookstore.com> or [http://www.reliance.com/docs\\_onl/online\\_stdrv.htm](http://www.reliance.com/docs_onl/online_stdrv.htm).

### 1.1 Getting Assistance from Reliance Electric

If you have any questions or problems with the products described in this instruction manual, contact your local Reliance Electric sales office.

For technical assistance, call 1-800-726-8112. Before calling, please review the troubleshooting section of this manual and check the Reliance Standard Drives website for additional information. When you call this number, you will be asked for the drive model number or catalog number and this instruction manual number.



# CHAPTER 2

## About the MD60 Drive

This chapter provides information about the MD60 AC drive, including:

- How to identify the drive
- Descriptions of NEMA ratings

### 2.1 Identifying the Drive by Model Number

Each drive can be identified by its model number, as shown in figure 2.1. The model number is on the shipping label and the drive nameplate. The model number includes the drive and any options. Drive model numbers are provided in table 2.1.

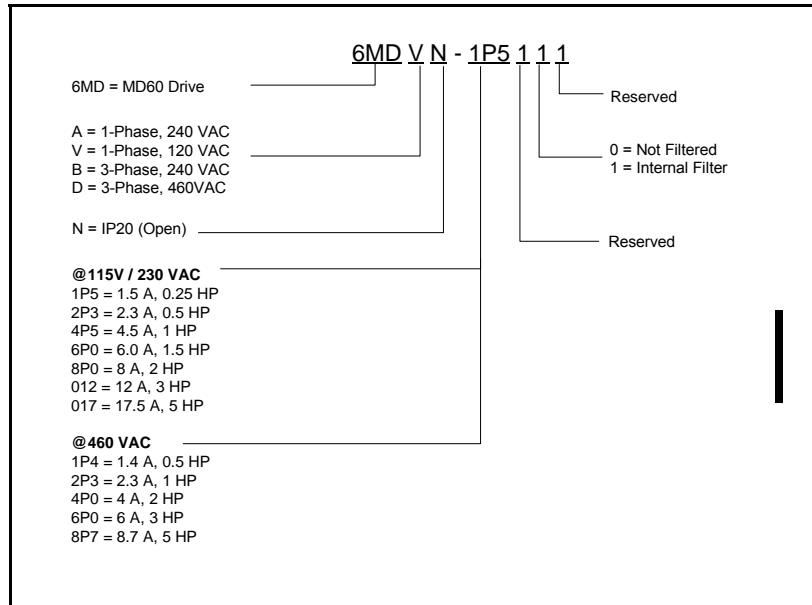

Figure 2.1 – Identifying the Drive by Model Number

## 2.2 MD60 Drive Ratings, Model Numbers, and Frame Sizes

Similar MD60 drive sizes are grouped into frame sizes to simplify re-ordering and dimensioning. Refer to figure 3.2 for the dimensions of each frame size.

Table 2.1 provides MD60 drive ratings, model numbers, and frame sizes.

Table 2.1 – Drive Ratings, Model Numbers, and Frame Sizes

Drive Ratings				Model Number	Frame Size
Input Voltage	kW	HP	Output Current		
115V, 50/60 Hz 1-Phase	0.2	0.25	1.5A	6MDVN-1P5101	A
	0.37	0.5	2.3A	6MDVN-2P3101	A
	0.75	1.0	4.5A	6MDVN-4P5101	B
	1.1	1.5	6.0A	6MDVN-6P0101	B
230V, 50/60 Hz 1-Phase With Integral EMC Filter	0.2	0.25	1.5A	6MDAN-1P5111	A
	0.37	0.5	2.3A	6MDAN-2P3111	A
	0.75	1.0	4.5A	6MDAN-4P5111	A
	1.5	2.0	8.0A	6MDAN-8P0111	B
230V, 50/60 Hz 1-Phase No Filter	0.2	0.25	1.5A	6MDAN-1P5101	A
	0.37	0.5	2.3A	6MDAN-2P3101	A
	0.75	1.0	4.5A	6MDAN-4P5101	A
	1.5	2.0	8.0A	6MDAN-8P0101	B
230V, 50/60 Hz 3-Phase	0.2	0.25	1.5A	6MDBN-1P5101	A
	0.37	0.5	2.3A	6MDBN-2P3101	A
	0.75	1.0	4.5A	6MDBN-4P5101	A
	1.5	2.0	8.0A	6MDBN-8P0101	A
	2.2	3.0	12.0A	6MDBN-012101	B
460V, 50/60 Hz 3-Phase	0.37	0.5	1.4A	6MDDN-1P4101	A
	0.75	1.0	2.3A	6MDDN-2P3101	A
	1.5	2.0	4.0A	6MDDN-4P0101	A
	2.2	3.0	6.0A	6MDDN-6P0101	B
	3.7	5.0	8.7A	6MDDN-8P7101	B

## 2.3 Kits

Table 2.2 lists kits for the MD60 drive. Contact Reliance Electric for more information about these kits.

Table 2.2 – Standard Kits

Kit Description	Model Number
MD60 Serial Converter and cables	MDCOMM-232
VS Utilities Software CD	RECOMM-VSUTIL
MD60 Serial Converter (includes VS Utilities Software)	MDCOMM-VSU232
NEMA 1/IP30 Kit (contains conduit box and converter cover)	6MD-NM1A 6MD-NM1B
Remote LCD OIM Nema 4x/12 (includes 2.9 meter cable)	MD4ALCD <sup>1</sup>
Remote Handheld OIM (Copy Cat Keypad; includes 1.0 meter cable)	MD1CC <sup>1</sup>
Bezel Kit (panel mount for Remote Handheld OIM)	MDBZL-N1
OIM Cable (1.0 meter OIM-to-RJ45 cable)	MDCBL-CC1
OIM Cable (2.9 meter OIM-to-RJ45 cable)	MDCBL-CC3
RJ45 Cable (2.0 meter RJ45-to-RJ45 cable, male-to-male connectors)	MDCBL-RJ45
Serial Cable (2.0 meter serial cable with a locking low profile connector to connect to the serial converter and a 9-pin sub-miniature D female connector to connect to a computer)	RECBL-SFC
RJ45 Splitter Cables	See Appendix G
Terminating Resistors (RJ45 120 Ohm resistors; 2 pieces)	AK-UO-RJ45-TRI
Terminal Block (RJ45 two-position terminal block; 5 pieces)	AK-UO-TB2P
Communications Option Kits	See Appendix E
Dynamic Brake Resistors	AK-R2-xxx <sup>1</sup>
EMI Filters	6MDF-xxx <sup>1</sup>

<sup>1</sup> See Appendix E for more information.

## 2.4 Storage Guidelines

If you need to store the drive, follow these recommendations to prolong drive life and performance:

- Store the drive within an ambient temperature range of -40° to +85° C.
- Store the drive within a relative humidity range of 0% to 95%, non-condensing.
- Do not expose the drive to a corrosive atmosphere.

# CHAPTER 3

## Mounting the Drive

This chapter provides information that must be considered when planning an MD60 drive installation and provides drive mounting information and installation site requirements.



**ATTENTION:** Only qualified electrical personnel familiar with the construction and operation of this equipment and the hazards involved should install, adjust, operate, or service this equipment. Read and understand this manual and other applicable manuals in their entirety before proceeding. Failure to observe this precaution could result in severe bodily injury or loss of life.

**ATTENTION:** Use of power correction capacitors on the output of the drive can result in erratic operation of the motor, nuisance tripping, and/or permanent damage to the drive. Remove power correction capacitors before proceeding. Failure to observe this precaution could result in damage to, or destruction of, the equipment.

**ATTENTION:** The user is responsible for conforming with all applicable local, national, and international codes. Failure to observe this precaution could result in damage to, or destruction of, the equipment.

### 3.1 General Requirements for the Installation Site

It is important to properly plan before installing an MD60 drive to ensure that the drive's environment and operating conditions are satisfactory.

The area behind the drive must be kept clear of all control and power wiring. Power connections may create electromagnetic fields that may interfere with control wiring or components when run in close proximity to the drive.

Read the recommendations in the following sections before continuing with the drive installation.

### 3.1.1 Operating Conditions

Before deciding on an installation site, consider the following guidelines:

- Protect the cooling fan by avoiding dust or metallic particles.
- Do not expose the drive to a corrosive atmosphere.
- Protect the drive from moisture and direct sunlight.
- Verify that the drive location will meet the environmental conditions specified in table 3.1.

Table 3.1 – Ambient Operating Temperatures and Mounting Clearances

Ambient Temperature		Enclosure Rating	Minimum Mounting Clearances
Minimum	Maximum		
-10°C (14°F)	40°C (104°F)	IP 20/Open Type	Use Mounting Option A (figure 3.1)
		IP 30/NEMA 1/ UL Type 1 <sup>1</sup>	Use Mounting Option B (figure 3.1)
	50°C (122°F)	IP 20/Open Type	Use Mounting Option B (figure 3.1)

<sup>1</sup> Rating requires installation of the MD60 NEMA 1/IP30 Kit.

### 3.1.2 Recommended Mounting Clearances

Refer to figure 3.1 for the minimum mounting clearances. Refer to section 3.1.3 for drive mounting dimensions.

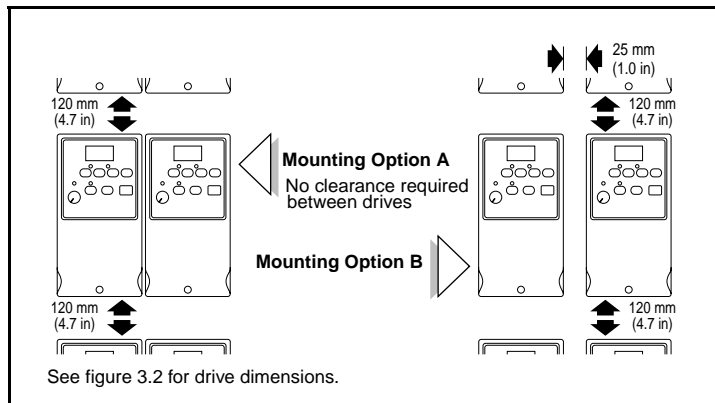

Figure 3.1 – Minimum Mounting Clearances

### 3.1.3 Mounting Dimensions for the MD60 Drive

Overall dimensions and weights are illustrated in figures 3.2 and 3.3 as an aid to calculating the total area required by the MD60 drive. Dimensions are in millimeters and (inches). Weights are in kilograms and (pounds). See table 2.1 for drive ratings by frame.

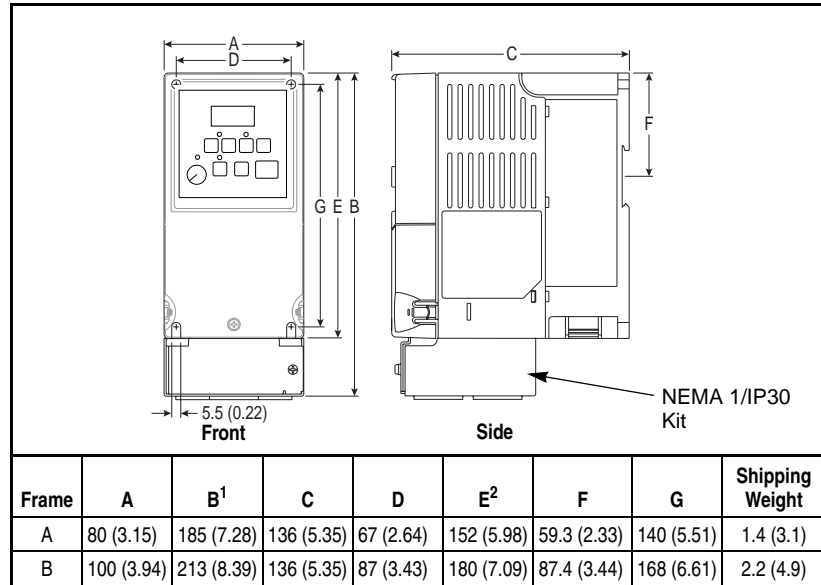

Figure 3.2 – Drive Dimensions - Front View

- <sup>1</sup> Height dimension includes NEMA 1/IP30 Kit; see figure 3.3.
- <sup>2</sup> Height dimension without NEMA 1/IP30 Kit.

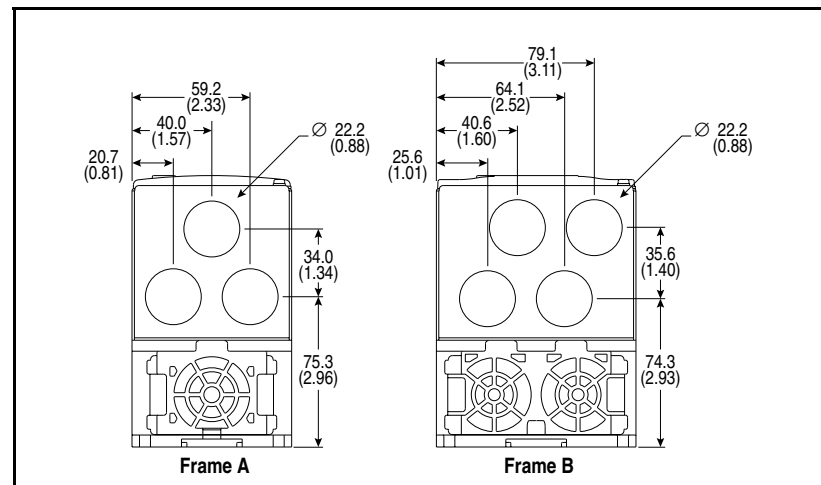

Figure 3.3 – Drive Dimensions - Bottom View

## 3.2 Mounting the Drive

Mount the drive upright on a flat, vertical, and level surface.

- Install on 35 mm DIN rail  
or
- Install with screws (see table 3.2).

Table 3.2 – Mounting Specifications

Minimum Panel Thickness	Screw Size	Mounting Torque
1.9 mm (0.0747 in)	M4 (#8-32)	1.56-1.96 N-m (14-17 in-lb)

### 3.2.1 Protecting the Drive from Debris

A plastic top panel is included with the drive. Install the panel to prevent debris from falling through the vents of the drive housing during installation. Remove the panel for IP 20/Open Type applications.

# CHAPTER 4

## Grounding the Drive



**ATTENTION:** The following information is merely a guide for proper installation. Rockwell Automation cannot assume responsibility for the compliance or the noncompliance to any code, national, local or otherwise for the proper installation of this drive or associated equipment. A hazard of personal injury and/or equipment damage exists if codes are ignored during installation.

The drive Safety Ground -  $\oplus$  must be connected to system ground. Ground impedance must conform to the requirements of national and local industrial safety regulations and/or electrical codes. The integrity of all ground connections should be periodically checked.

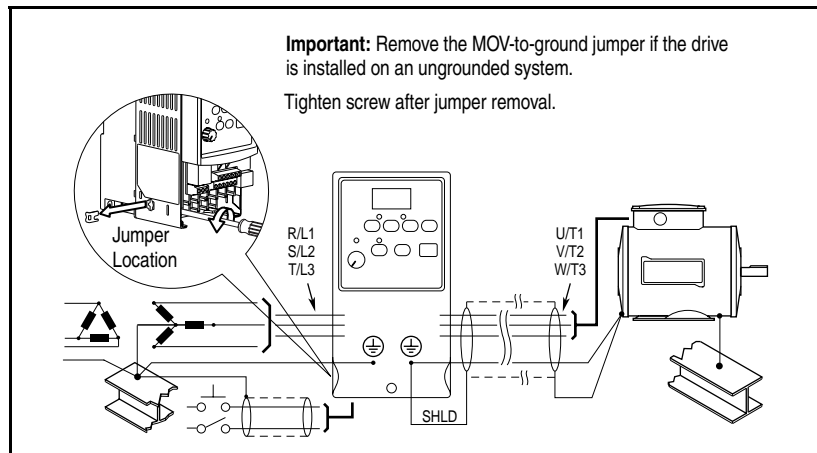

Figure 4.1 – Typical Grounding

For installations within a cabinet, a single safety ground point or ground bus bar connected directly to building steel should be used. All circuits including the AC input ground conductor should be grounded independently and directly to this point/bar.

## Ground Fault Monitoring

If a system ground fault monitor is to be used, only Type B (adjustable) devices should be used to avoid nuisance tripping.

## Safety Ground - (PE)

This is the safety ground for the drive that is required by code. One of these points must be connected to adjacent building steel (girder, joist), a floor ground rod, or bus bar. Grounding points must comply with national and local industrial safety regulations and/or electrical codes.

## Motor Ground

The motor ground must be connected to one of the ground terminals on the drive.

## Shield Termination - SHLD

Either of the safety ground terminals located on the power terminal block provides a grounding point for the motor cable shield. The **motor cable** shield connected to one of these terminals (drive end) should also be connected to the motor frame (motor end). Use a shield terminating or EMI clamp to connect the shield to the safety ground terminal. The NEMA 1/IP30 Kit may be used with a cable clamp for a grounding point for the cable shield.

When shielded cable is used for **control and signal wiring**, the shield should be grounded at the source end only, not at the drive end.

## 4.1 RFI Filter Grounding

Using single-phase drives with integral filter, or an external filter with any drive rating, may result in relatively high ground leakage currents. Therefore, the **filter must only be used in installations with grounded AC supply systems and be permanently installed and solidly grounded** (bonded) to the building power distribution ground.

Ensure that the incoming supply neutral is solidly connected (bonded) to the same building power distribution ground. Grounding must not rely on flexible cables and should not include any form of plug or socket that would permit inadvertent disconnection. Some local codes may require redundant ground connections. The integrity of all connections should be periodically checked.

# CHAPTER 5

## Installing Power Wiring



**ATTENTION:** The user is responsible for conforming with all applicable local and national codes. Failure to observe this precaution could result in damage to, or destruction of, the equipment.

**ATTENTION:** To avoid a possible shock hazard caused by induced voltages, unused wires in the conduit must be grounded at both ends. For the same reason, if a drive sharing a conduit is being serviced or installed, all drives using this conduit should be disabled. This will help minimize the possible shock hazard from “cross-coupled” power leads.

This chapter provides instructions on wiring output wiring to the motor and installing AC input power wiring.

### 5.1 Opening the Cover

To access the power terminal block:

- Step 1. Open the cover.
  - a. Press and hold in the tabs on each side of the cover.
  - b. Pull the cover out and up to release (refer to figure 5.1).

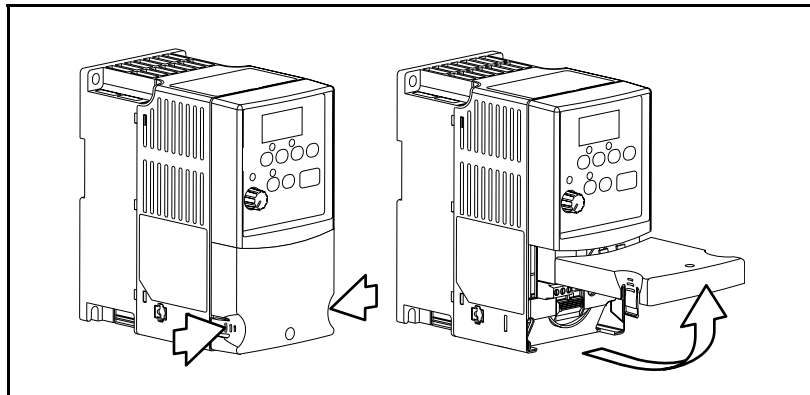

Figure 5.1 – Opening the Cover

- Step 2. Remove the finger guard (refer to figure 5.2).
- a. Press in and hold the locking tab.
  - b. Slide finger guard down and out.

Replace the finger guard when wiring is complete.

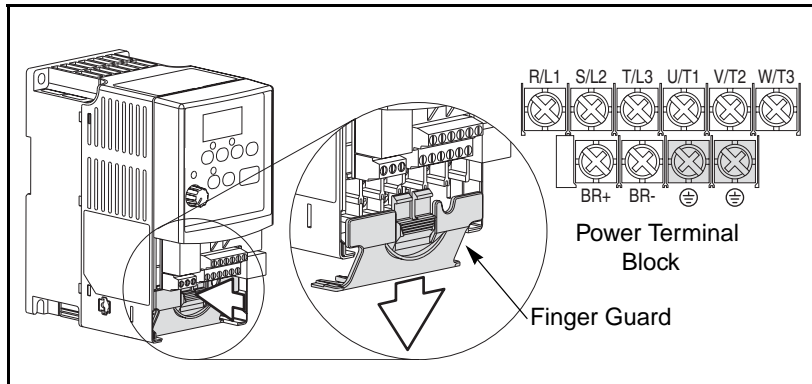

Figure 5.2 – Removing the Finger Guard

## 5.2 Verifying Drive AC Input Ratings Match Available Power

It is important to verify that plant power meets the input power requirements of the drive's circuitry. Refer to table 5.4 for input power rating specifications. Be sure input power to the drive corresponds to the drive nameplate voltage and frequency.

### 5.2.1 Ungrounded Distribution Systems



**ATTENTION:** MD60 drives contain protective MOVs that are referenced to ground. These devices should be disconnected if the drive is installed on an ungrounded distribution system.

To prevent drive damage, the MOVs connected to ground should be disconnected if the drive is installed on an ungrounded distribution system where the line-to-ground voltages on any phase could exceed 125% of the nominal line-to-line voltage.

## Disconnecting MOVs

To disconnect MOVs, you must remove the external jumper located on the lower left side of the front of the drive.

To remove the jumper, use the following procedure and refer to figures 5.3 and 5.4.

- Step 1. Open the cover.
- Step 2. Locate the screw below and to the left of the power terminal block.
- Step 3. Turn the screw counterclockwise to loosen.
- Step 4. Pull the jumper completely out of the drive chassis.
- Step 5. Tighten the screw to keep it in place.

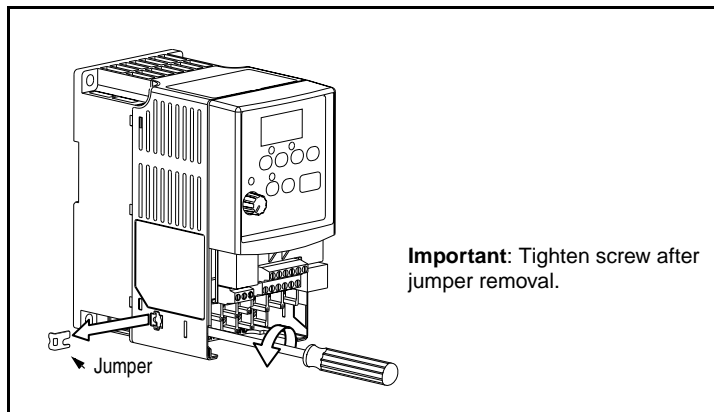

Figure 5.3 – Jumper Location (A Frame Shown)

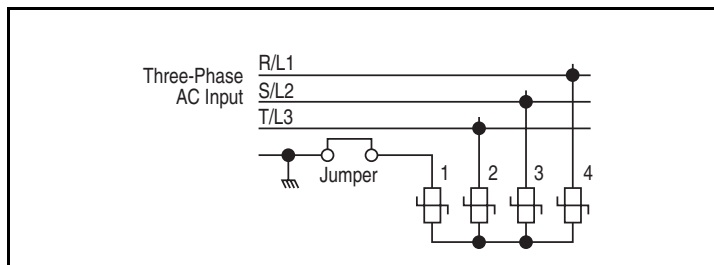

Figure 5.4 – Phase-to-Ground MOV Removal

## 5.2.2 Input Power Conditioning

The drive is suitable for direct connection to input power within the rated voltage of the drive (see table 5.4). Table 5.1 lists certain input power conditions that may cause component damage or reduction in product life. If any of the conditions exist, install one of the devices listed in the "Corrective Action" column in table 5.1 on the line side of the drive.

**Important:** Only one device per branch circuit is required. It should be mounted closest to the branch and sized to handle the total current of the branch circuit.

Table 5.1 – Corrective Actions for Input Power Conditions

Input Power Condition	Corrective Action
Low line impedance (less than 1% line reactance)	<ul style="list-style-type: none"> <li>• Install line reactor<sup>1</sup></li> </ul>
Greater than 120 kVA supply transformer	
Line has power factor correction capacitors	<ul style="list-style-type: none"> <li>• Install isolation transformer</li> </ul>
Line has frequent power interruptions	
Line has intermittent noise spikes in excess of 6000V (lightning)	
Phase-to-ground voltage exceeds 125% of normal line-to-line voltage	<ul style="list-style-type: none"> <li>• Remove MOV jumper to ground and install isolation transformer with grounded secondary, if necessary.</li> </ul>
Ungrounded distribution system	

<sup>1</sup> Contact Reliance Electric for application and ordering information.

## 5.3 Power Wiring Specifications

Table 5.2 – Power Wiring Specifications

Power Wire Rating	Recommended Copper Wire
Unshielded 600V, 75°C (167°F) THHN/THWN	15 mils insulated, dry location
Shielded 600V, 90°C (194°F) RHH/RHW-2	Belden 29501-29507 or equivalent
Shielded Tray rated 600V, 90°C (194°F) RHH/RHW-2	Shawflex 2ACD/3ACD or equivalent

## 5.4 Power Terminal Block Connections

Table 5.3 – Power Terminal Block Specifications

Frame	Maximum Wire Size <sup>1</sup>	Minimum Wire Size <sup>1</sup>	Torque
A	3.3 mm <sup>2</sup> (12 AWG)	0.8 mm <sup>2</sup> (18 AWG)	1.7-2.2 Nm (16-19 in-lb)
B	5.3 mm <sup>2</sup> (10 AWG)	1.3 mm <sup>2</sup> (16 AWG)	

<sup>1</sup> Maximum/minimum sizes that the terminal block will accept. These are not recommendations.

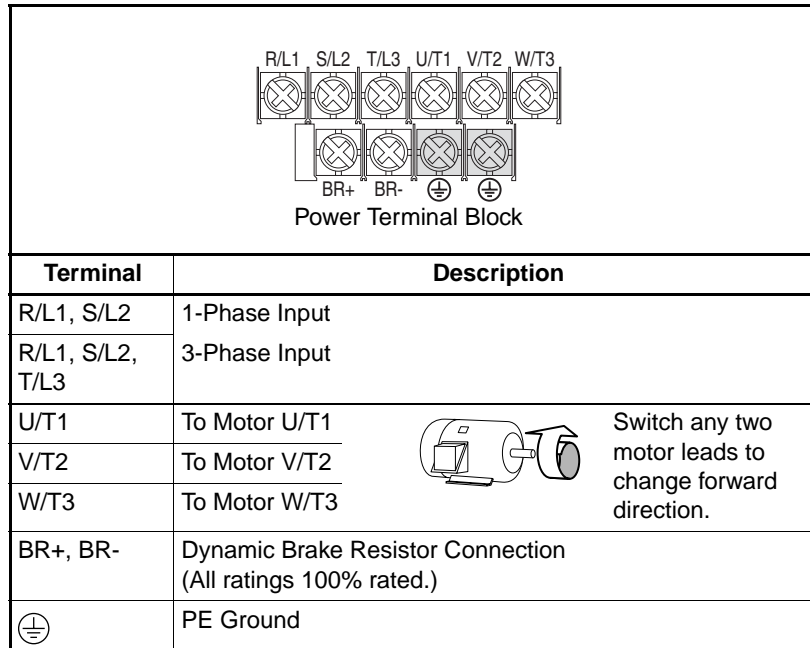

Figure 5.5 – Power Terminal Block Connections

## 5.5 Fuses and Circuit Breakers

The MD60 drive does not provide branch short circuit protection. This product should be installed with either input fuses or an input circuit breaker. National and local industrial safety regulations and/or electrical codes may determine additional requirements for these installations.

Table 5.4 provides drive ratings and recommended AC line input fuse and circuit breaker information. Both types of short circuit protection are acceptable for UL and IEC requirements. Sizes listed are the recommended sizes **based on 40 degree C and the U.S. N.E.C.** Other country, state or local codes may require different ratings.



**ATTENTION:** To guard against personal injury and/or equipment damage caused by improper fusing or circuit breaker selection, use only the recommended line fuses/circuit breakers specified in table 5.4.

### Fuses

The MD60 drive has been UL tested and approved for use with input fuses. The ratings in table 5.4 are the minimum recommended values for use with each drive rating. The devices listed in this table are provided to serve as a guide.

**If fuses are chosen as the desired protection method,** refer to the recommended types listed below. If available amp ratings do not match the tables provided, the **closest** fuse rating that exceeds the drive rating should be chosen.

- IEC – BS88 (British Standard) Parts 1 & 2<sup>1</sup>, EN60269-1, Parts 1 & 2, type gG or equivalent should be used.
- UL Class CC, T or J must be used.<sup>2</sup>

---

<sup>1</sup> Typical designations include, but may not be limited to the following:  
Parts 1 & 2: AC, AD, BC, BD, CD, DD, ED, EFS, EF, FF, FG, GF, GG, GH.

<sup>2</sup> Typical designations include:  
Type CC - KTK-R, FNQ-R  
Type J - JKS, LPJ  
Type T - JJS, JJN

## Circuit Breakers

The “other devices” listings in table 5.4 include both circuit breakers (inverse time or instantaneous trip) and self-protecting motor starters. **If one of these is chosen as the desired protection method**, the following requirements apply.

- IEC and UL – Both types of devices are acceptable for IEC and UL installations.

Table 5.4 – Drive, Fuse, and Circuit Breaker Ratings

Drive Ratings								
Model Number	Output Ratings		Input Ratings			Branch Circuit Protection		Power Dissipation
	kW (HP)	Amps	Voltage Range	kVA	Amps	Fuse Rating	Other Devices	IP20 Open Watts
<b>100 - 115V AC 1-Phase Input; 0 - 230 V, 3-Phase Output</b>								
6MDVN-1P5101	0.2 (0.25)	1.5	90-126	0.75	6.0	10	10	25
6MDVN-2P3101	0.37 (0.5)	2.3	90-126	1.15	9.0	15	15	30
6MDVN-4P5101	0.75 (1.0)	4.5	90-126	2.25	18.0	30	30	50
6MDVN-6P0101	1.1 (1.5)	6.0	90-126	3.0	24.0	40	40	70
<b>200 - 240V AC 1-Phase Input; 0 - 230 V, 3-Phase Output</b>								
6MDAN-1P5111	0.2 (0.25)	1.5	180-265	0.75	5.0	10	5	25
6MDAN-2P3111	0.37 (0.5)	2.3	180-265	1.15	6.0	10	10	30
6MDAN-4P5111	0.75 (1.0)	4.5	180-265	2.25	10.0	15	15	50
6MDAN-8P0111	1.5 (2.0)	8.0	180-265	4.0	18.0	30	25	80
<b>200 - 240V AC 3-Phase Input; 0 - 230 V, 3-Phase Output</b>								
6MDBN-1P5101	0.2 (0.25)	1.5	180-265	0.75	1.8	3	5	25
6MDBN-2P3101	0.37 (0.5)	2.3	180-265	1.15	2.5	6	5	30
6MDBN-4P5101	0.75 (1.0)	4.5	180-265	2.25	5.2	10	7	50
6MDBN-8P0101	1.5 (2.0)	8.0	180-265	4.0	9.5	15	15	80
6MDBN-012101	2.2 (3.0)	12.0	180-265	5.5	15.5	25	25	115
6MDBN-017101	3.7 (5.0)	17.5	180-265	8.6	21.0	35	30	165
<b>380 - 480V AC 3-Phase Input; 0 - 480 V, 3-Phase Output</b>								
6MDDN-1P4101	0.37 (0.5)	1.4	340-528	1.4	1.8	3	3	30
6MDDN-2P3101	0.75 (1.0)	2.3	340-528	2.3	3.2	6	4	40
6MDDN-4P0101	1.5 (2.0)	4.0	340-528	4.0	5.7	10	7	60
6MDDN-6P0101	2.2 (3.0)	6.0	340-528	5.9	7.5	15	10	90
6MDDN-8P7101	3.7 (5.0)	8.7	340-528	8.6	9.0	15	15	145

Note: For carrier frequencies above 4 kHz, see figure 9.9.

## 5.6 Motor Cable Types Acceptable for 200-600 Volt Installations

### General

A variety of cable types are acceptable for drive installations. For many installations, unshielded cable is adequate provided it can be separated from sensitive circuits. As an approximate guide, allow a spacing of 0.3 meters (1 foot) for every 10 meters (32.8 feet) of length. In all cases, long parallel runs must be avoided. Do not use cable with an insulation thickness less than 15 mils (0.4 mm/0.015 in). Do not route more than three sets of motor leads in a single conduit to minimize “cross talk”. If more than three drive/motor connections per conduit are required, shielded cable must be used.

- UL installations in 50°C ambient must use 600V, 75°C or 90°C wire.
- For UL installations in 40°C ambient, 600V, 75°C or 90°C wire is recommended.
- Use copper wire only. Wire gauge requirements and recommendations are based on 75° C. Do not reduce wire gauge when using higher temperature wire.

### Unshielded

THHN, THWN or similar wire is acceptable for drive installation in dry environments provided adequate free air space and/or conduit fill rates limits are provided. **Do not use THHN or similarly coated wire in wet areas.** Any wire chosen must have a minimum insulation thickness of 15 mil and should not have large variations in insulation concentricity.

### Shielded

Refer to table 5.5 for acceptable shielded motor cable types.

Table 5.5 – Shielded Motor Cable Types Acceptable for 200-600 Volt Installations

Location	Rating/Type	Description
Standard (Option 1)	600V, 75°C or 90°C (167°F or 194°F) RHH/RHW-2 Belden 29501-29507 or equivalent	<ul style="list-style-type: none"><li>• Four tinned copper conductors with XLPE insulation</li><li>• Foil shield and tinned copper drain wire with 85% braid coverage</li><li>• PVC jacket</li></ul>

Table 5.5 – Shielded Motor Cable Types Acceptable for 200-600 Volt Installations

Location	Rating/Type	Description
Standard (Option 2)	Tray rated 600V, 75°C or 90°C (167°F or 194°F) RHH/RHW-2 Shawflex 2ACD/3ACD or equivalent	<ul style="list-style-type: none"> <li>• Three tinned copper conductors with XLPE insulation</li> <li>• 5 mil single helical copper tape (25% overlap min.) with three bare copper grounds in contact with shield</li> <li>• PVC jacket</li> </ul>
Class I & II; Division I & II	Tray rated 600V, 75°C or 90°C (167°F or 194°F) RHH/RHW-2	<ul style="list-style-type: none"> <li>• Three tinned copper conductors with XLPE insulation</li> <li>• 5 mil single helical copper tape (25% overlap min.) with three bare copper grounds in contact with shield</li> <li>• PVC copper grounds on #10 AWG and smaller</li> </ul>

## 5.7 Reflected Wave Protection

The drive should be installed as close to the motor as possible. Installations with long motor cables may require the addition of external devices, such as reactors, to limit voltage reflections at the motor (reflected wave phenomena). Contact Reliance Electric for recommendations.

The reflected wave data applies to all frequencies 2 to 16 kHz. For 240 V ratings, reflected wave effects do not need to be considered.

Table 5.6 – Maximum Cable Length Recommendation

Reflected Wave		
380-480V Ratings	Motor Insulation Rating	Motor Cable Only <sup>1</sup>
	1000 Vp-p	15 meters (49 feet)
	1200 Vp-p	40 meters (131 feet)
	1600 Vp-p	170 meters (558 feet)

<sup>1</sup> Longer cable lengths can be achieved by installing devices on the output of the drive. Consult factory for recommendations.

## 5.8 Output Disconnect

The drive is intended to be commanded by control input signals that will start and stop the motor. A device that routinely disconnects then reapplies output power to the motor for the purpose of starting and stopping the motor should not be used. If it is necessary to disconnect power to the motor while the drive is providing output power, an auxiliary contact should be used to simultaneously disable drive control run commands.

# CHAPTER 6

## Installing Control Wiring

This chapter describes how to wire the signal and I/O terminal strip for stop, speed feedback, and remote control signals.

To access the control terminal block, remove the drive cover (refer to chapter 5).

Terminal block connections are detailed in figure 6.1.

### 6.1 Stop Circuit Requirements



**ATTENTION:** You must provide an external, hardwired emergency stop circuit outside of the drive circuitry. This circuit must disable the system in case of improper operation. Uncontrolled machine operation can result if this procedure is not followed. Failure to observe this precaution could result in bodily injury.

Depending upon the requirements of the application, the MD60 drive can be configured to provide either a coast-to-rest or a ramp-to-rest operational stop without physical separation of the power source from the motor. A coast-to-rest stop turns off the transistor power device drivers. A ramp-to-rest stop fires the transistor power device drivers until the motor comes to a stop, and then turns off the power devices.

In addition to the operational stop, you must provide a hardwired emergency stop external to the drive. The emergency stop circuit must contain only hardwired electromechanical components. Operation of the emergency stop must not depend on electronic logic (hardware or software) or on the communication of commands over an electronic network or link.

Note that the hardwired emergency stop you install can be used at any time to stop the drive.

### 6.1.1 Compliance with Machinery Safety Standard EN 60204-1:1992

This section applies to you if you must comply with machinery safety standard EN 60204-1:1992, part 9.2.5.4, Emergency Stop.

The MD60 drive coast-to-rest stop is a category 0 operational stop. The ramp-to-rest stop is a category 1 operational stop. You can also implement a category 2 stop with power maintained to the motor at zero speed.

The required external hardwired emergency stop must be either a category 0 or 1 stop, depending on your risk assessment of the associated machinery. To fully comply with machinery safety standard EN60204-1:1992, part 9.2.5.4, at least one of the two stop methods must be a category 0 stop.

## 6.2 Motor Start/Stop Precautions



**ATTENTION:** A contactor or other device that routinely disconnects and reapplies the AC line to the drive to start and stop the motor can cause drive hardware damage. The drive is designed to use control input signals that will start and stop the motor. If used, the input device must not exceed one operation per minute or drive damage can occur. Failure to observe this precaution can result in damage to, or destruction of, equipment.

**ATTENTION:** The drive start/stop control circuitry includes solid-state components. If hazards due to accidental contact with moving machinery or unintentional flow of liquid, gas or solids exist, an additional hardwired stop circuit may be required to remove the AC line to the drive. When the AC line is removed, there will be a loss of any inherent regenerative braking effect that might be present - the motor will coast to a stop. An auxiliary braking method may be required.

Important points to remember about I/O wiring:

- Always use copper wire.
- Wire with an insulation rating of 600V or greater is recommended.
- Control and signal wires should be separated from power wires by at least 0.3 meters (1 foot).

**Important:** I/O terminals labeled “Common” **are not** referenced to the safety ground (PE) terminal and are designed to greatly reduce common mode interference.



**ATTENTION:** Driving the 4-20 mA analog input from a voltage source could cause component damage. Verify proper configuration prior to applying input signals.

## 6.3 I/O Wiring Recommendations

Table 6.1 – Recommended Control and Signal Wire<sup>1</sup>

Wire Type(s)	Description	Minimum Insulation Rating
Belden 8760/ 9460 (or equiv.)	0.8 mm <sup>2</sup> (18AWG), twisted pair, 100% shield with drain.	300 V 60° C (140° F)
Belden 8770 (or equiv.)	0.8 mm <sup>2</sup> (18AWG), 3 conductor, shielded for remote pot only.	

<sup>1</sup> If the wires are short and contained within a cabinet which has no sensitive circuits, the use of shielded wire may not be necessary, but is always recommended.

Table 6.2 – I/O Terminal Block Specifications

Maximum Wire Size <sup>1</sup>	Minimum Wire Size <sup>1</sup>	Torque
1.3 mm <sup>2</sup> (16 AWG)	0.13 mm <sup>2</sup> (26 AWG)	0.5 to 0.8 Nm (4.4 in-lb)

<sup>1</sup> Maximum / minimum that the terminal block will accept. These are not recommendations.

### 6.3.1 Maximum Cable Length Recommendations

Do not exceed control wiring length of 30 meters (100 feet). Control signal cable length is highly dependent on electrical environment and installation practices. To improve noise immunity, the I/O terminal block Common must be connected to ground terminal/protective earth. If using the RS485 port, Terminal 16 should also be connected to ground terminal/protective earth.



## 6.4.1 I/O Wiring Examples

Input/Output	Connection Example	
<b>Potentiometer</b> 1-10k Ohm Pot. Recommended (2 watt minimum)	P038 (Speed Reference) = 2 "0-10V Input" 	
<b>Analog Input</b> 0 to +10V, 100k ohm impedance 4-20 mA, 100 ohm impedance	Voltage P038 (Speed Reference) = 2 "0-10V Input" 	Current P038 (Speed Reference) = 3 "4-20mA Input" 
<b>2 Wire SRC Control Non-Reversing</b> P036 (Start Source) = 2, 3 or 4 Input must be active for the drive to run. When input is opened, the drive will stop as specified by P037 (Stop Mode). If desired, a User Supplied 24 V DC power source can be used. Refer to the "External Supply (SRC)" example.	Internal Supply (SRC) 	External Supply (SRC) 
<b>2 Wire SNK Control Non-Reversing</b>	Internal Supply (SNK) 	

Figure 6.2 – I/O Wiring Examples

Input/Output	Connection Example	
<p><b>2 Wire SRC Control - Run FWD/Run REV</b></p> <p>P036 (Start Source) = 2, 3, or 4</p> <p>Input must be active for the drive to run. When input is opened, the drive will stop as specified by P037 (Stop Mode).</p> <p>If both Run Forward and Run Reverse inputs are closed at the same time, an undetermined state could occur.</p>	<p>Internal Supply (SRC)</p> 	<p>External Supply (SRC)</p> 
<p><b>2 Wire SNK Control - Run FWD/Run REV</b></p>	<p>Internal Supply (SNK)</p> 	
<p><b>3 Wire SRC Control - Non-Reversing</b></p> <p>P036 (Start Source) = 1</p> <p>A momentary input will start the drive. A stop input to I/O Terminal 01 will stop the drive as specified by P037 (Stop Mode).</p>	<p>Internal Supply (SRC)</p> 	<p>External Supply (SRC)</p> 
<p><b>3 Wire SNK Control - Non-Reversing</b></p>	<p>Internal Supply (SNK)</p> 	
<p><b>3 Wire SRC Control - Reversing</b></p> <p>P036 (Start Source) = 1</p> <p>A momentary input will start the drive. A stop input to I/O Terminal 01 will stop the drive as specified by P037 (Stop Mode). I/O Terminal 03 determines direction.</p>	<p>Internal Supply (SRC)</p> 	<p>External Supply (SRC)</p> 

Figure 6.2 – I/O Wiring Examples

Input/Output	Connection Example
3 Wire SNK Control - Reversing	<p>Internal Supply (SNK)</p>

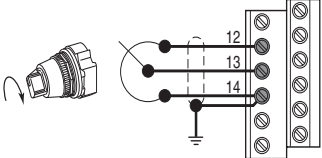
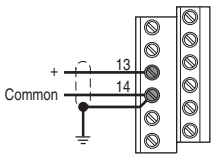
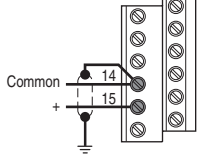
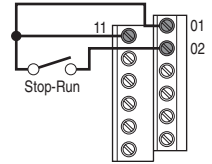
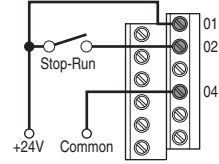
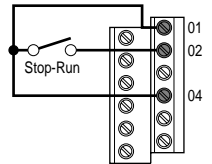
Figure 6.2 – I/O Wiring Examples

## 6.4.2 Typical Multiple Drive Connection Examples

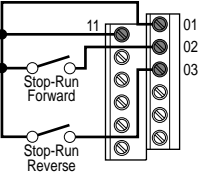
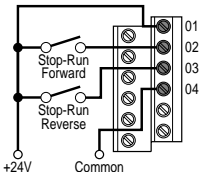
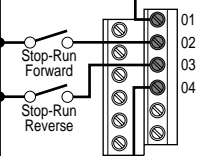
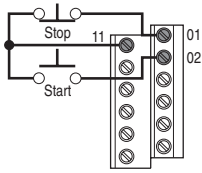
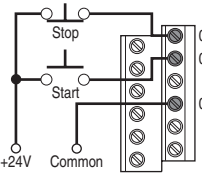
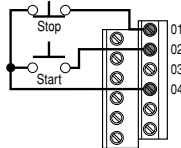
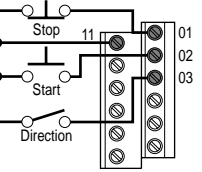
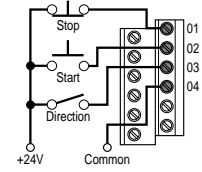
Table 6.3 – Typical Multiple Drive Connection Examples

Input	Connection Example
<p><b>Multiple Digital Input Connections</b></p> <p>Customer Inputs can be wired per External Supply (SRC) or Internal Supply (SNK).</p>	<p>When connecting a single input such as Run, Stop, Reverse or Preset Speeds to multiple drives, it is important to connect I/O Terminal 04 common together for all drives. If they are to be tied into another common (such as earth ground or separate apparatus ground) only one point of the daisy chain of I/O Terminal 04 should be connected.</p>
<p><b>Multiple Analog Connections</b></p>	<p>When connecting a single potentiometer to multiple drives it is important to connect I/O Terminal 14 common together for all drives. I/O Terminal 14 common and I/O Terminal 13 (potentiometer wiper) should be daisy-chained to each drive. All drives must be powered up for the analog signal to be read correctly.</p>

## 6.5 Start and Speed Reference Control

The drive speed command can be obtained from a number of different sources. The source is normally determined by P038 (Speed Reference). However, when A051 or A052 (Digital Inx Select) is set to option 2, 4, 5, or 6, and the digital input is active, A051 or A052 will override the speed reference commanded by P038 (Speed Reference). See figure 6.3 for the override priority.

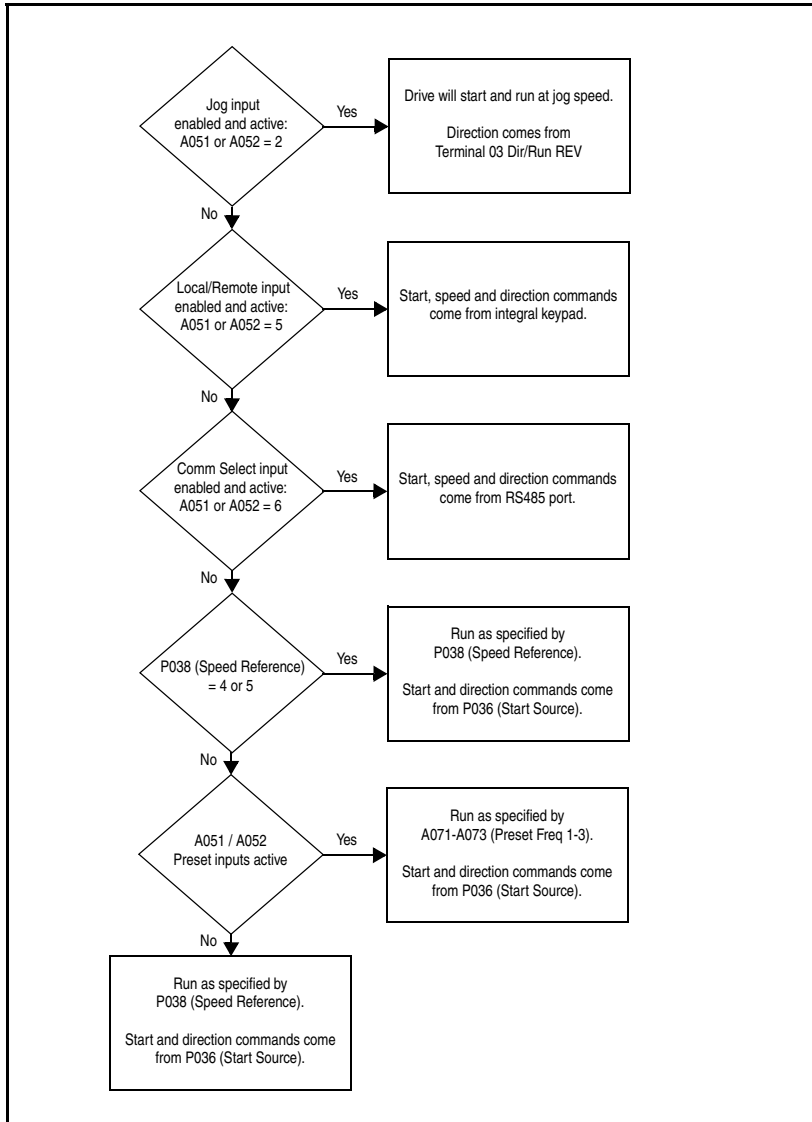

Figure 6.3 – Override Priority for the Speed Reference Command

## 6.6 Accel/Decel Selection

The selection of Accel/Decel rates can be made through digital inputs, RS485 communications and/or parameters. See figure 6.4.

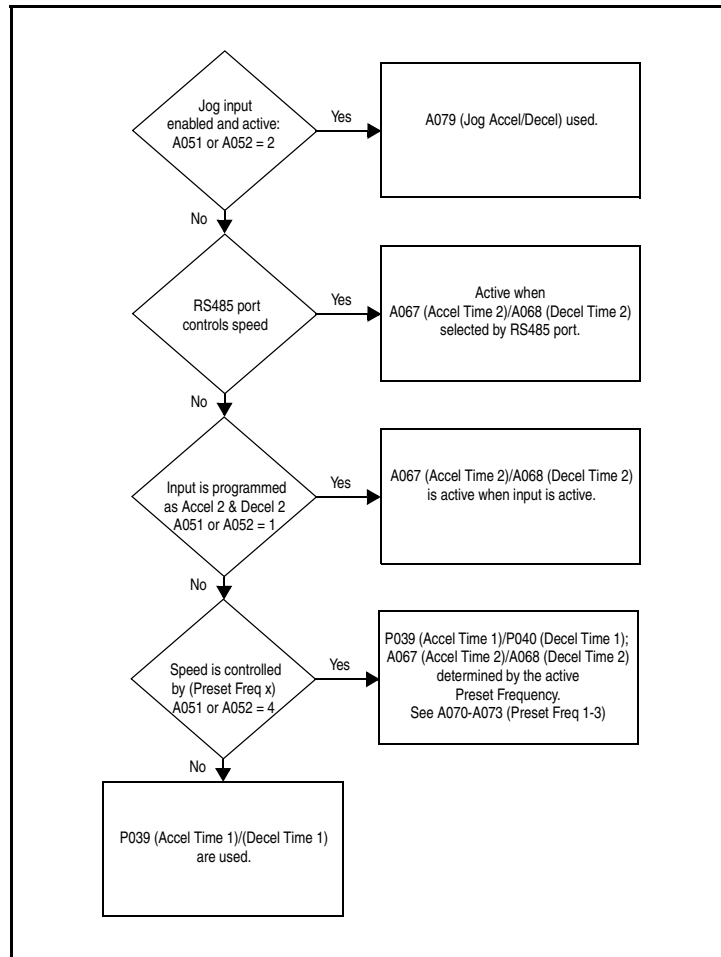

Figure 6.4 – Accel/Decel Selection



# CHAPTER 7

## Completing the Installation

This chapter provides instructions on how to perform a final check of the installation before and after power is applied to the drive.



**ATTENTION:** Only qualified electrical personnel familiar with the construction and operation of this equipment and the hazards involved should start and adjust it. Read and understand this manual in its entirety before proceeding. Failure to observe this precaution could result in severe bodily injury or loss of life.

### 7.1 Checking the Installation Before Applying Power to the Drive



**ATTENTION:** The drive contains high voltage capacitors that take time to discharge after removal of mains supply. Before working on the drive, ensure isolation of mains supply from line inputs [R, S, T (L1, L2, L3)]. Wait three (3) minutes for capacitors to discharge to safe voltage levels. Darkened display LEDs is not an indication that capacitors have discharged to safe voltage levels. Failure to observe this precaution could result in severe bodily injury or loss of life.

**ATTENTION:** You must provide an external, hardwired emergency stop circuit outside of the drive circuitry. This circuit must disable the system in case of improper operation. Uncontrolled machine operation can result if this procedure is not followed. Failure to observe this precaution could result in bodily injury.

To verify the condition of the installation:

- Confirm that all inputs are connected to the correct terminals and are secure.
- Verify that AC line power at the disconnect device is within the rated value of the drive.
- Verify that any external digital control power is 24 volts DC.

- Verify that the Sink (SNK)/Source (SRC) Setup DIP Switch is set to match your control wiring scheme. See figure 6.1 for the location of this switch.

**Important:** The default control scheme is Source (SRC). The Stop terminal is jumpered (I/O Terminals 01 and 11) to allow starting from the keypad. If the control scheme is changed to Sink (SNK), the jumper must be removed from I/O Terminals 01 and 11 and installed between I/O Terminals 01 and 04.

- Verify that the Stop input is present or the drive will not start.

**Important:** If I/O Terminal 01 is used as a stop input, the jumper between I/O Terminals 01 and 11 must be removed.

## 7.2 Powering Up After Installation is Complete

To verify that the drive is installed correctly and is receiving the proper line voltage, apply AC power and control voltages to the drive.

Become familiar with the integral keypad features before setting any parameters. Refer to chapter 8 for information about the integral keypad and programming the drive. To simplify drive setup, the most commonly programmed parameters are organized in the Basic parameter group.

If a fault code appears on power up, refer to chapter 10, Troubleshooting the Drive, for an explanation of the fault code.

# CHAPTER 8

## Using the Integral Keypad to Program and Control the Drive

Factory-default parameter values allow the drive to be controlled from the integral keypad. No programming is required to start, stop, change direction, or control speed directly from the integral keypad.

This chapter provides an overview of the integrated keypad and how to use it to program and control the MD60 drive.

Parameter descriptions are provided in chapter 9.

### 8.1 Keypad Components

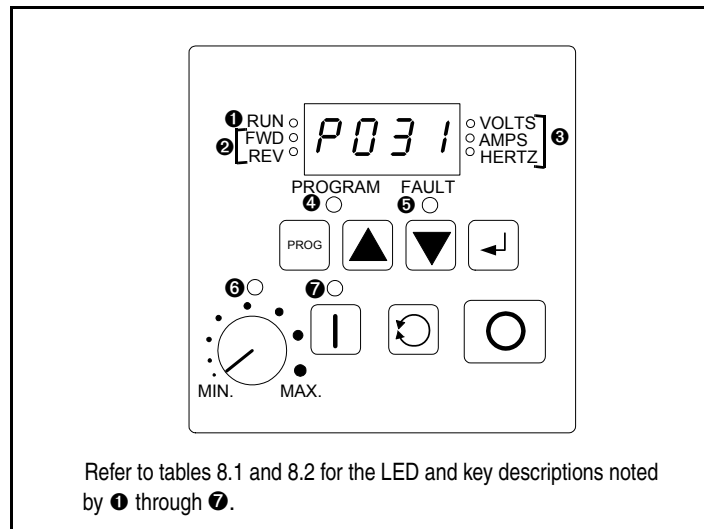

Figure 8.1 – Integral Keypad

## 8.1.1 Display Description

The alpha-numeric display indicates the following:

- Parameter number
- Parameter value
- Fault code

## 8.1.2 LED Descriptions

Refer to figure 8.1 for the location of the LEDs described in table 8.1.







Table 8.1 – LED Descriptions

No.	LED	LED State	Description
①	RUN	Steady Red	Indicates the drive is running.
②	FWD REV	Flashing Red	Drive has been commanded to change direction. Indicates actual motor direction while decelerating to zero.
		Steady Red	Indicates the commanded motor direction.
③	VOLTS AMPS HERTZ	Steady Red	Indicates the units of the parameter value being displayed.
④	PROGRAM	Steady Red	Indicates the drive is in program mode and the parameter value can be changed.
⑤	FAULT	Flashing Red	Indicates drive is faulted.
⑥	Pot Status	Steady Green	Indicates potentiometer on integral keypad is active.
⑦	Start Key Status	Steady Green	Indicates Start key on integral keypad is active. The Reverse key is also active unless disabled by A095 (Reverse Disable).

### 8.1.3 Key Descriptions

Refer to figure 8.1 for the location of the keys described in table 8.2.

Table 8.2 – Key Descriptions

Key	Name	Description
	Program	<ul style="list-style-type: none"> <li>• Enter/exit program mode.</li> <li>• Scroll through parameter groups.</li> <li>• Back up one step in programming menu.</li> <li>• Cancel a change to a parameter value.</li> </ul>
	Up Arrow Down Arrow	<ul style="list-style-type: none"> <li>• Scroll through P and A parameters.</li> <li>• Increase/decrease the value of a flashing digit.</li> <li>• In Display Mode, increases/ decreases internal frequency parameter if that parameter is currently controlling the drive commanded speed.</li> </ul>
	Enter	<ul style="list-style-type: none"> <li>• Display value of P or A parameter.</li> <li>• Save a change to a parameter value.</li> <li>• Scroll through display (d) parameters.</li> </ul>
	Potentiometer	Control drive speed. Default is active. Controlled by parameter P038.
	Start	Start the drive. Default is active. Controlled by parameter P036.
	Reverse	Reverse direction of the motor. Default is active. Controlled by parameters P036 and A095.
	Stop	<ul style="list-style-type: none"> <li>• Stop the drive (if drive is running).</li> <li>• Clear fault (if drive is stopped).</li> </ul> Controlled by parameter P037.

## 8.2 About Parameters

To program the drive for a specific application, you adjust the appropriate parameters. The parameters are used to define characteristics of the drive.

There are three types of parameters:

- **Numbered List Parameters**

Numbered list parameters allow a selection from two or more options. Each item is represented by a number.

Example: Start Source (P036)

- **Bit Parameters**

Bit parameters have individual bits associated with features or conditions. If the bit is 0, the feature is off or the condition is false. If the bit is 1, the feature is on or the condition is true.

Example: Drive Status (d006)

- **Numeric Parameters**

These parameters have a single numerical value (for example, 0.1 volts).

Example: Motor NP Volts (P031)

Parameters are also either configurable or tunable, or read-only.

**Configurable parameters** can be adjusted or changed only while the drive is stopped.

**Tunable parameters** can be adjusted or changed while the drive is running or stopped.

**Read-only parameters** cannot be adjusted.

## 8.3 How Parameters are Organized















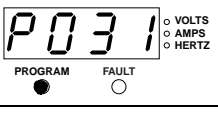

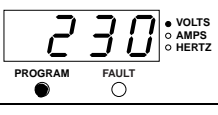

Parameters are organized into three Parameter Groups:

- The Basic Parameter Group, (Pnnn) contains the most commonly used parameters to simplify the start-up process.
- The Advanced Parameter Group (Annn) contains parameters used for more advanced applications.
- The Display Parameter Group (dnnn) contains parameters that indicate actual drive conditions.



## 8.4 Viewing and Adjusting Basic (P) and Advanced (A) Parameters

Use the following procedure to view and adjust the Basic and Advanced parameters.

Table 8.3 – Viewing and Adjusting Basic (P) and Advanced (A) Parameters

Procedure	Sample Display
Step 1. Press  until the desired parameter group is displayed. The PROGRAM LED will turn on to indicate the drive is in program mode.	
Step 2. Press   to scroll through the parameters in the selected parameter group.	
Step 3. Press  to view the value of the displayed parameter.	
Step 4. Press  or   . The adjustable value will flash on the display.	
Step 5. Use   to adjust the value.	
Step 6. Press  to accept the value. The value stops flashing.	
Step 7. Press  to return to the parameter number.	







To adjust additional parameters, repeat steps 2 through 7.

To exit a parameter without saving the value, press  instead of .

## 8.5 Viewing the Display (d) Parameters

Use the procedure in table 8.4 to view Display parameters.

Table 8.4 – Viewing the Display (d) Parameters

Procedure	Sample Display
Step 1. Press  to scroll through the parameter menus until the Display Group parameters are displayed. The PROGRAM LED will be off to indicate the drive is in display mode.	
Step 2. Press  to scroll through the Display Group parameters until the desired Display parameter is displayed.	
Step 3. The parameter value will be displayed 3 seconds after  is released.	

To view additional Display parameters, press  to return to the Display Group parameter list and scroll through the parameter list as described in step 2.

Note that the last user-selected Display parameter is saved when power is removed and is displayed by default when power is re-applied.



# CHAPTER 9

## Parameter Descriptions

The following information is provided for each parameter along with its description:

- Parameter Number:** Unique number assigned to each parameter.
- Parameter Name:** Unique name assigned to each parameter.
- Range:** Predefined parameter limits or selections. Note that a negative Hz value indicates reverse rotation.
- Default:** Factory default setting.
- See also:** Associated parameters that may provide additional or related information.

### What the Symbols Mean

Symbol	Meaning
	Drive must be stopped before changing parameter value.
	32-bit parameter. Parameters marked 32-bit will have two parameter numbers when using RS485 communications and programming software.

The parameters are presented in numerical order in the sections that follow. Refer to Appendix C for a list of parameters cross-referenced by parameter name.

## 9.1 Basic Program Group Parameters

The Basic Program Group contains the most commonly used parameters to simplify the start-up process.

---

### P031 Motor NP Volts



**Range:** 20 VAC to Drive Rated Volts

**Default:** Based on Drive Rating

**See also:** A084

Set to the motor nameplate rated volts.

---

### P032 Motor NP Hertz



**Range:** 10 to 240 Hz

**Default:** 60 Hz

**See also:** A084

Set to the motor nameplate rated frequency.

---

### P033 Motor OL Current

**Range:** 0.0 to (Drive Rated Amps x 2)

**Default:** Based on Drive Rating

**See also:** A089, A090, A098

Set to the maximum allowable motor current. The drive will fault on an F7 Motor Overload if the value of this parameter is exceeded by 150% for 60 seconds or 200% for 3 seconds.

---

### P034 Minimum Frequency

**Range:** 0.0 to 240.0 Hz

**Default:** 0.0 Hz

**See also:** d001, d002, d013, P035, A110, A112, A115

Sets the lowest frequency the drive will output continuously.

---

### P035 Maximum Frequency



**Range:** 0 to 240 Hz

**Default:** 60 Hz

**See also:** d001, d002, d013, P034, A078, A111, A113, A115

Sets the highest frequency the drive will output.

## P036 Start Source



**Range:** 0 = Keypad  
1 = 3-Wire  
2 = 2-Wire  
3 = 2-Wire Level-Sensitive  
4 = 2-Wire High-Speed  
5 = RS485 Port

**Default:** 0 = Keypad

**See also:** d012, P037

Sets the control scheme used to start the drive.

Refer to section 6.6, Start and Speed Reference Control, for details about how other drive settings can override the setting of this parameter.

**Important:** P037 (Stop Mode) does not control I/O Terminal 01 except when P036 (Start Source) is set for 3-Wire Control. In all other instances, I/O Terminal 01 is a coast-to-stop input.

**Important:** For all settings except option 3, the drive must receive a leading edge from the start input for the drive to start after a stop input, loss of power, or fault condition.

**0 = Keypad (Default):** Integral keypad controls drive operation. I/O Terminal 01 (Stop) on terminal block = coast to stop. When 0 is selected, the Reverse key is also active unless disabled by A095 (Reverse Disable).

**1 = 3-Wire:** I/O Terminal 1 “Stop” = stop according to the value set in P037 (Stop Mode). Refer to figure 6.2 for wiring examples.

**2 = 2-Wire:** I/O Terminal 1 “Stop” = coast to stop. Refer to figure 6.2 for wiring examples.

**3 = 2-Wire Level-Sensitive:** Drive will restart after a Stop command when:

- Stop is removed and
- Start is held active.



**ATTENTION:** When P036 (Start Source) is set to option 3, and the Run input is maintained, the Run inputs do not need to be toggled after a Stop input for the drive to run again. A Stop function is provided only when the Stop input is active (open). Failure to observe this precaution could result in severe bodily injury.

**4 = 2-Wire High-Speed:** Outputs are kept in a ready-to-run state. The drive will respond to a Start command within 10 ms. I/O Terminal 01 (Stop) on the terminal block = coast to stop.

**Important:** There is greater potential voltage on the power output terminals (U/T1, V/T2, W/T3) when using this option.

**5 = RS485 Port:** Remote communications. I/O Terminal 01 (Stop) on terminal block = coast to stop.

**The following describes some differences in operation of commanding the drive via RS485 communications for different firmware versions:**

**Important:** When commanding jog via the RS485 communications port on drives with firmware version 1.04 or earlier, the jog command will follow the commanded direction from I/O terminal 03. On firmware version 1.05 and later, the commanded direction will be provided via the RS485 communications port.

**Important:** When sending a continuous start command via the RS485 communications port on drives with firmware version 1.04 or earlier, a maintained stop input is required to stop the drive. Once the stop input is inactive, the drive will restart. On firmware versions 1.05 and later, once a stop input is received, the start command must transition from high to low to high for the drive to start.

## P037 Stop Mode

**Range:** 0 = Ramp, Clear Fault  
1 = Coast, Clear Fault  
2 = DC Brake, Clear Fault  
3 = DC Brake with Shutoff, Clear Fault  
4 = Ramp  
5 = Coast  
6 = DC Brake  
7 = DC Brake with Shutoff

**Default:** 1 = Coast, Clear Fault

**See also:** P036, A080, A081, A082, A105

Active stop mode for all stop sources except as noted below.

When this parameter is set to option 0, 1, 2, or 3, the stop input (i.e., keypad stop, I/O Terminal 01, or RS485 port) can be used to clear an active fault. Refer to chapter 10 for other methods for clearing fault conditions.

**Important:** P037 (Stop Mode) does not control I/O Terminal 01 except when P036 (Start Source) is set for 3-Wire Control. In all other instances, I/O Terminal 01 is a coast-to-stop input.

**Important:** When using options 2, 3, 6, or 7, parameters A080 (DC Brake Time) and A081 (DC Brake Level) must be set to meet application requirements.

**0 = Ramp, Clear Fault:** Ramp to stop. Stop command clears active fault and resets the drive.

**1 = Coast, Clear Fault (Default):** Coast to stop. Stop command clears active fault and resets the drive.

**2 = DC Brake, Clear Fault:** DC injection braking stop. Stop command clears active fault and resets the drive.

**3 = DC Brake w/Shutoff, Clear Fault:** DC injection braking stop with auto shutoff.

- Standard DC injection braking for value set in A080 (DC Brake Time).  
OR
- Drive shuts off if current limit is exceeded.

Stop command clears active fault and resets the drive.

**4 = Ramp:** Ramp to stop.

**5 = Coast:** Coast to stop.

**6 = DC Brake:** DC injection braking stop.

**7 = DC Brake w/Shutoff:** DC injection braking stop with auto shutoff.

- Standard DC injection braking for value set in A080 (DC Brake Time).  
OR
- Drive shuts off if drive detects motor has stopped.

---

## P038 Speed Reference

**Range:** 0 = Drive Potentiometer  
1 = Internal Frequency  
2 = 0 to 10 V Input / Remote Potentiometer  
3 = 4 to 20 mA Input  
4 = Preset Frequency 0 to 3  
5 = RS485 Port

**Default:** 0 = Drive Potentiometer

**See also:** d001, d002, d012, P039, P040, A051, A052, A069, A070-A073, A110-A113

Sets the source of the speed reference to the drive.

**Important:** When A051 or A052 (Digital Inx Select) is set to option 2, 4, 5, or 6, and the digital input is active, A051 or A052 will override the speed reference commanded by this parameter. Refer to section 6.6, Start and Speed Reference Control, for details about how other drive settings can override the setting of this parameter.

**0 = Drive Potentiometer (Default):** Internal frequency command from the potentiometer on the integral keypad.

**1 = Internal Frequency:** Internal frequency command from A069 (Internal Frequency).

**2 = 0 to 10 V Input/Remote Potentiometer:** External frequency command from the 0 to 10 V analog input or remote potentiometer.

**3 = 4 to 20 mA Input:** External frequency command from the 4 to 20 mA analog input.

**4 = Preset Frequency 0 to 3:** External frequency command as defined by A070-A073 (Preset Frequency x) when A051 and A052 (Digital Inx Select) are programmed as "Preset Frequencies," and the digital inputs are active.

**5 = RS485 Port:** External frequency command from the communications port.

### P039 Accel Time 1

**Range:** 0.1 to 600.0 sec

**Default:** 5.0 sec

**See also:** P038, P040, A051, A052, A067, A070-A073

Sets the rate of acceleration for all speed increases. See figure 9.1.

Maximum Frequency / Accel Time = Accel Rate

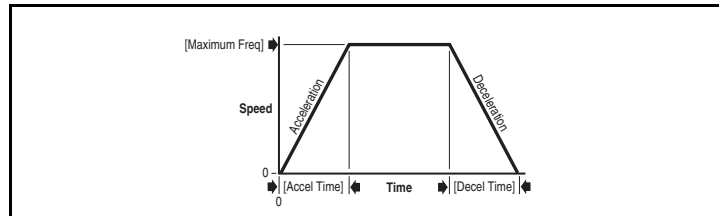

Figure 9.1 – Accel Time 1 (P039)

### P040 Decel Time 1

**Range:** 0.1 to 600.0 sec

**Default:** 5.0 sec

**See also:** P038, P039, A051, A052, A068, A070-A073

Sets the rate of deceleration for all speed decreases. See figure 9.2.

Maximum Frequency / Decel Time = Decel Rate

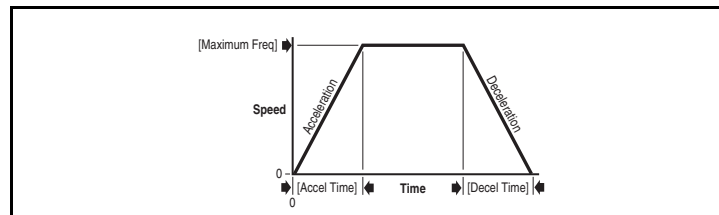

Figure 9.2 – Decel Time 1 (P040)

### P041 Reset to Defaults



**Range:** 0 = Idle State  
1 = Reset Defaults

**Default:** 0 = Idle State

**See also:** N/A

Resets all parameter values to factory defaults. After the reset function is complete, this parameter sets itself back to 0. This selection causes an F48 Params Defaulted fault.

## 9.2 Advanced Group Parameters

**A051 Digital In1 Select (I/O Terminal 05)**

**A052 Digital In2 Select (I/O Terminal 06)**



**Range:**

- 0 = Not Used
- 1 = Accel 2 & Decel 2<sup>1</sup>
- 2 = Jog
- 3 = Auxiliary Fault
- 4 = Preset Frequencies
- 5 = Local
- 6 = RS485 Port<sup>1</sup>
- 7 = Clear Fault
- 8 = Ramp Stop, CF
- 9 = Coast Stop, CF
- 10 = DCIj Stop, CF
- 11 = Jog Forward
- 12 = Jog Reverse
- 13 = 10V In Ctrl
- 14 = 20mA In Ctrl
- 26 = Anlg Invert

**Default:** 4 = Preset Frequencies

**See also:** A067, A068, A070 through A073, A078, A079

<sup>1</sup> Can be tied to only one input.

Selects the function for the digital inputs. Refer to the flowchart in section 6.6 for more information on speed reference control priority.

**0 = Not Used.**

**1 = Accel Time 2 (A067) and Decel Time 2 (A068):** When this option is selected, Accel Time 2 and Decel Time 2 are used for all ramp rates except Jog. Refer to the flowchart in section 6.7 for more information about accel/decel selection.

**2 = Jog:** When input is present, the drive accelerates according to the value set in Jog Accel/Decel (A079) and ramps to the value set in Jog Frequency (A078). When the input is removed, the drive ramps to a stop according to the value set in Jog Accel/Decel. A valid Start command will override this input.

**3 = Auxiliary Fault:** When enabled, an F2 Auxiliary Input fault will occur when the input is removed.

**4 = Preset Frequencies (Default)** See Preset Frequency x (A070 to A073).

**Important:** Digital Input 1 or 2 has priority for frequency control when it is programmed as a Preset Speed and is active.

**5 = Local:** When active, sets the integral keypad as the start source and the potentiometer on the integral keypad as the speed source.

**6 = RS485 Port:** When active, sets communications device as default start/speed command source.

**7 = Clear Fault:** When active, clears an active fault and resets the drive.

**8 = Ramp Stop, CF:** Causes drive to immediately ramp to a stop regardless of how Stop Mode (P037) is set.

**9 = Coast Stop, CF:** Causes drive to immediately coast to a stop regardless of how Stop Mode (P037) is set.

**10 = DCInjStop, CF:** Causes drive to immediately begin a DC Injection stop regardless of how Stop Mode (P037) is set.

**11 = Jog Forward:** Drive accelerates to Jog Frequency (A078) according to Jog Accel/Decel (A079) and ramps to stop when input becomes inactive. A valid start will override this command.

**12 = Jog Reverse:** Drive accelerates to Jog Frequency (A078) according to Jog Accel/Decel (A079) and ramps to stop when input becomes inactive. A valid start will override this command.

**13 = 10V In Ctrl:** Selects 0-10V or +/- 10V control as the frequency reference. Start source is not changed.

**14 = 20mA In Ctrl:** Selects 4-20mA control as the frequency reference. Start source is not changed.

**15-25:** Reserved

**26 = Anlg Invert:** Inverts the scaling of the analog input levels set in Anlg In 0-10V Lo (A110) and Anlg In 0-10V Hi (A111) or Anlg In4-20mA Lo (A112) and Anlg In4-20mA Hi (A113).

---

## A055 Relay Output Select

**Range:**

- 0 = Ready (Not Faulted)
- 1 = At Frequency
- 2 = Motor Running
- 3 = Reverse
- 4 = Motor Overload
- 5 = Ramp Regulated
- 6 = Above Frequency
- 7 = Above Current
- 8 = Above DC Bus Volts
- 9 = Retries Exhausted
- 10 = Above Anlg V
- 20 = Param Control
- 21 = Non Rec Fault

**Default:** 0 = Ready (Not Faulted)

**See also:** P033, A056, A092

Sets the condition that changes the state of the output relay contacts.

**0 = Ready (Not Faulted) (Default):** Relay changes state when power is applied. This indicates that the drive is ready for operation.

**1 = At Frequency:** Drive reaches commanded frequency.

**2 = Motor Running:** Motor is receiving power from the drive.

**3 = Reverse:** Drive is commanded to run in reverse direction.

**4 = Motor Overload:** Motor overload condition exits.

**5 = Ramp Regulated:** Ramp regulator is modifying the programmed accel/decel times to avoid an overcurrent or overvoltage fault from occurring.

**6 = Above Frequency:** Drive exceeds the frequency (Hz) value set in Relay Output Level (A056).

**7 = Above Current:** Drive exceeds the current (% Amps) value set in Relay Output Level (A056).

**Important:** Value for Relay Output Level must be entered in percent of drive rated output current.

**8 = Above DC Bus Volts:** Drive exceeds the DC bus voltage value set in Relay Output Level (A056).

**9 = Retries Exhausted:** Value set in Auto Restart Tries (A092) is exceeded.

**10 = Above Anlg V:** Analog input voltage (I/O Terminal 13) exceeds the value set in Relay Out Level (A056). This parameter setting can also be used to indicate a PTC trip point when the input (I/O Terminal 13) is wired to a PTC and external resistor. Use A056 to set threshold.

**11-19:** Reserved

**20 = ParamControl:** Enables the output to be controlled over network communications by wiring to Relay Out Level (A056). 0=Off, 1=On.

**21 = NonRec Fault:** Value set in Auto Rstrt Tries (A092) is exceeded, is set to zero with drive defaulted, or a non-resettable fault occurs.

## A056 Relay Output Level

32

**Range:** 0.0 to 9999 (see table 9.1)  
**Default:** 0.0  
**See also:** A055

Sets the trip point for the output relay if the value of Relay Output Select (A055) is 6, 7, 8, 10 or 20. See table 9.1.

Table 9.1 – Trip Points for Digital Output Relay

A055 Setting	Range
6 (Above Frequency)	0 to 240 Hz
7 (Above Current)	0 to 180%
8 (Above DC Bus Volts)	0 to 815 V
10	0 to 100%
20	0 to 1

## A067 Accel Time 2

**Range:** 0.0 to 600.0 sec  
**Default:** 10.0 sec  
**See also:** P039

Sets the rate of acceleration for speed increases if A051 or A052 is set to option 1 (Accel 2 and Decel 2). See figure 9.3.

Maximum Frequency / Accel Time = Accel Rate.

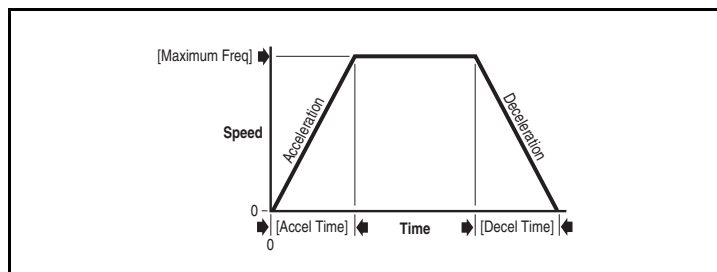

Figure 9.3 – Accel Time 2 (A067)

## A068 Decel Time 2

**Range:** 0.1 to 600.0 sec

**Default:** 10.0 sec

**See also:** P040

Sets the rate of deceleration for speed decreases if A051 or A052 is set to option 1 (Accel 2 and Decel 2). See figure 9.4.

Maximum Frequency / Decel Time = Decel Rate

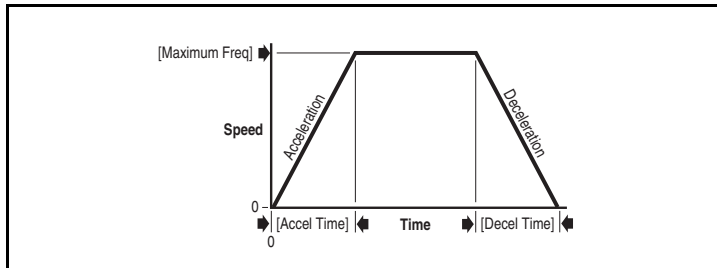

Figure 9.4 – Decel Time 2 (A068)

## A069 Internal Frequency

**Range:** 0.0 to 240 Hz

**Default:** 0.0 Hz

**See also:** P038

Provides the frequency command to the drive when Speed Reference (P038) is set to 1 (Internal Frequency). When enabled, this parameter will change the frequency command in “real time”

using the integral keypad   keys when in program mode.

**A070 Preset Frequency 0<sup>1</sup>**  
**A071 Preset Frequency 1**  
**A072 Preset Frequency 2**  
**A073 Preset Frequency 3**

**Range:** 0.0 to 240.0 Hz

**Default:** 0.0

**See also:** P038, A051, A052

<sup>1</sup> To activate Preset Frequency 0, set P038 (Speed Reference) to option 4 (Preset Frequency 0-3).

Provides a fixed frequency command value when Digital Inx Select (A051, A052) is set to option 4 (Preset 1 & 2). Digital Input 1 and Digital Input 2 determine which of the presets are used. See table 9.2 and refer to figures 6.3 and 6.4.

Table 9.2 – Selecting the Reference Source Using Presets

Input State of Digital In 1 (I/O Terminal 05)	Input State of Digital In 2 (I/O Terminal 06)	Frequency Source	Accel/Decel Parameter Used <sup>1</sup>
0	0	Preset Freq 0	Accel Time 1 / Decel Time 1
1	0	Preset Freq 1	Accel Time 1 / Decel Time 1
0	1	Preset Freq 2	Accel Time 2 / Decel Time 2
1	1	Preset Freq 3	Accel Time 2 / Decel Time 2

<sup>1</sup> When a digital input is set to Accel 2 & Decel 2, that input overrides the settings in this table.

**A078 Jog Frequency**

**Range:** 0.0 to Maximum Frequency

**Default:** 10.0 Hz

**See also:** P035, A051, A052, A079

Sets the output frequency when a jog command is issued. See A051, A052 for information on how to jog the drive.

**A079 Jog Accel/Decel**

**Range:** 0.1 to 600.0 sec

**Default:** 10.0 sec

**See also:** A051, A052, A078

Sets the acceleration and deceleration time when a jog command is issued. Refer to A051, A052 for information on how to jog the drive.

## A080 DC Brake Time

**Range:** 0.0 to 90.0 sec

**Default:** 0.0 sec

**See also:** A081

Sets the length of time DC brake current is “injected” into the motor. Refer to A081 (DC Brake Level).

## A081 DC Brake Level

**Range:** 0.0 to (Drive Amps x 1.8)

**Default:** Amps x 0.5

**See also:** P037, A080

Defines the maximum DC brake current, in amps, applied to the motor when Stop Mode (P037) is set to either DC Brake or Ramp. See figure 9.5.



**ATTENTION:** If a hazard of injury due to movement of equipment or material exists, an auxiliary mechanical braking device must be used.

**ATTENTION:** This feature should not be used with synchronous or permanent magnet motors. Motors may be demagnetized during braking.

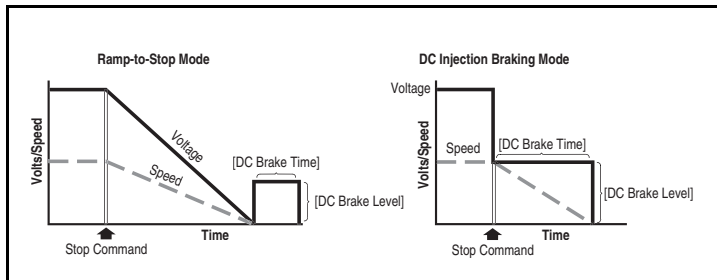

Figure 9.5 – DC Brake Level (A081)

## A082 DB Resistor Select



**Range:** 0 = Disabled  
1 = Reliance Electric Standard Resistor (5% Duty Cycle)  
2 = No Protection (100% Duty Cycle)  
3 to 99 = Duty Cycle Limited (3% to 99% Duty Cycle)

**Default:** 0 = Disabled

**See also:** N/A

Enables/disables external dynamic braking.

## A083 S Curve%

**Range:** 0 to 100%

**Default:** 0% (Disabled)

**See also:** N/A

Sets the percentage of acceleration or deceleration time that is applied to the ramp as S Curve. Time is added, 1/2 at the beginning and 1/2 at the end of the ramp.

For example: If Accel Time = 10 seconds, and the S Curve% setting is 50%, the S Curve time will be  $10 \times 0.5 = 5$  seconds. Total time will be  $10 + 5 = 15$  seconds.

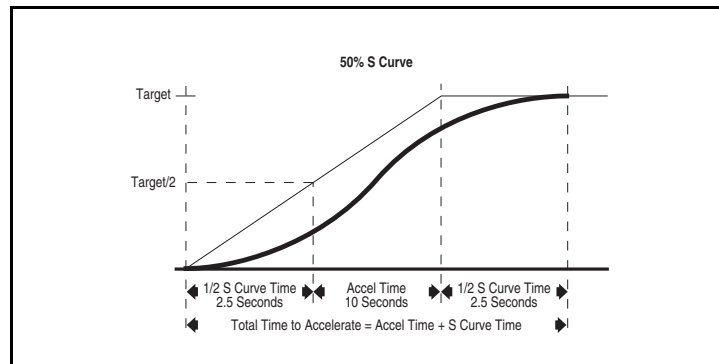

Figure 9.6 – S Curve% (A083) Examples

## A084 Start Boost

**Range:** Settings in% of base voltage at 50% of Motor Nameplate Hertz (P032)

**Variable Torque:**

- 1 = 30.0
- 2 = 35.0
- 3 = 40.0
- 4 = 45.0

**Constant Torque:**

- 5 = 0.0 no IR Compensation
- 6 = 0.0
- 7 = 2.5
- 8 = 5.0
- 9 = 7.5
- 10 = 10.0
- 11 = 12.5
- 12 = 15.0
- 13 = 17.5
- 14 = 20.0

**Default:** 8 = 5.0  
7 = 2.5 (for 5 HP drives only)

**See also:** P031

Sets the boost voltage (% of P031 (Motor NP Volts)) and redefines the Volts per Hz curve. Note that the drive may add additional voltage unless option 5 is selected. See figure 9.7.

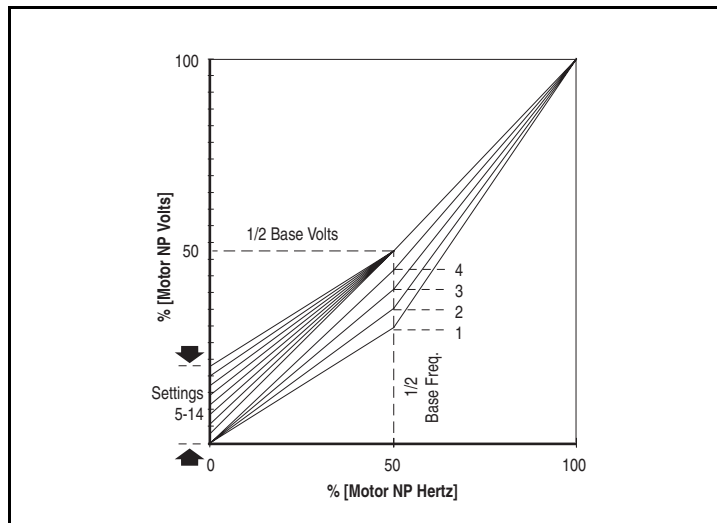

Figure 9.7 – Start Boost (A084)

---

**A088 Maximum Voltage**

**Range:** 20 to Drive Rated Volts  
**Default:** Drive Rated Volts  
**See also:** N/A

Sets the highest voltage the drive will output.

---

**A089 Current Limit**

**Range:** 0.1 to (Drive Rated Amps x 1.8)  
**Default:** Drive Rated Amps x 1.8  
**See also:** N/A

Maximum output current allowed before current limiting occurs.

---

**A090 Motor OL Select**

**Range:** 0 = No Derate  
1 = Minimum Derate  
2 = Maximum Derate  
**Default:** 0 = No Derate  
**See also:** P032

Drive provides Class 10 motor overload protection. Settings 0-2 select the derating factor for the  $I^2t$  overload function. See figure 9.8.

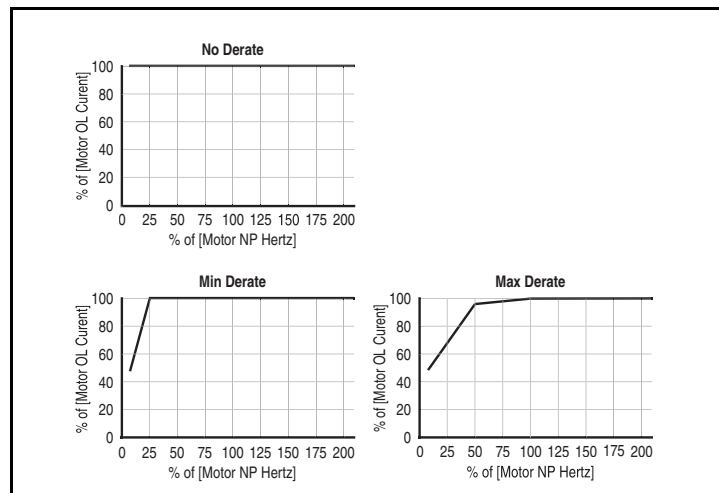

Figure 9.8 – Motor OL Select (A090)

## A091 PWM Frequency

**Range:** 2.0 to 16.0 kHz

**Default:** 4.0 kHz

**See also:** N/A

Sets the carrier frequency for the PWM output waveform. Figure 9.9 provides derating guidelines based on the PWM frequency setting.

**Important:** Ignoring derating guidelines can cause reduced drive performance.

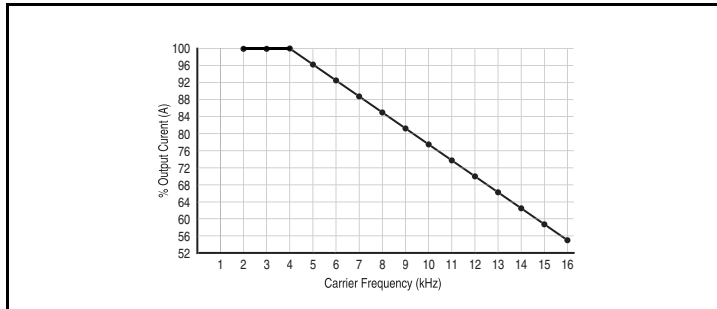

Figure 9.9 – Derating Guidelines Based on PWM Frequency (A091) Selection

## A092 Auto Restart Tries

**Range:** 0 to 9

**Default:** 0

**See also:** A093

Sets the maximum number of times the drive attempts to reset a fault and restart. Refer to section 10.1.2 for more information on the Auto Restart/Run feature.



**ATTENTION:** Equipment damage and/or personal injury may result if this parameter is used in an inappropriate application. Do not use this function without considering applicable local, national, and international codes, standards, regulations, or industry guidelines.

---

**A093 Auto Restart Delay**

**Range:** 0.0 to 120.0 sec  
**Default:** 1.0 sec  
**See also:** A092

Sets the time between restart attempts when Auto Restart Tries (A092) is set to a value other than zero. Refer to section 10.1.2 for more information on the Auto Restart/Run feature.

---

**A094 Start At Power Up**

**Range:** 0 = Disabled  
1 = Enabled  
**Default:** 0 = Disabled  
**See also:** N/A

Enables/disables a feature that allows a Start or Run command to automatically cause the drive to resume running at commanded speed after drive input power is restored. Requires a digital input configured for Run or Start and a valid start contact.

This parameter will not function if parameter P036 (Start Source) is set to option 1 (3-Wire) or option 4 (2-Wire High Speed).



**ATTENTION:** Equipment damage and/or personal injury may result if this parameter is used in an inappropriate application. Do not use this function without considering applicable local, national, and international codes, standards, regulations, or industry guidelines.

---

**A095 Reverse Disable**

**Range:** 0 = Reverse Enabled  
1 = Reverse Disabled  
**Default:** 0 = Reverse Enabled  
**See also:** N/A

Enables/disables the function that allows the direction of motor rotation to be changed. The reverse command may come from a digital command, the keypad, or a serial command. All reverse inputs including two-wire Run Reverse will be ignored with reverse disabled.

---

## A096 Flying Start Enable

**Range:** 0 = Disabled  
1 = Enabled

**Default:** 0 = Disabled

**See also:** N/A

Enables/disables feature that allows the drive to reconnect to a spinning motor at actual RPM.



**ATTENTION:** When starting with this feature enabled, the motor may temporarily run up to the maximum speed setting before settling at the speed setpoint. Stay clear of rotating machinery. Failure to observe this precaution could result in bodily injury.

---

## A097 Compensation

**Range:** 0 = Disabled  
1 = Electrical  
2 = Mechanical  
3 = Both

**Default:** 1 = Electrical

**See also:** N/A

Enables/disables correction options that may improve problems with motor instability.

**Electrical** = Some drive/motor combinations have inherent instabilities which are exhibited as non-sinusoidal motor currents. This setting attempts to correct this condition.

**Mechanical** = Some drive/motor combinations have mechanical resonances which can be excited by the drive current regulator. This setting slows down the current regulator response and attempts to correct this condition.

---

**A098 SW Current Trip**

**Range:** 0.0 to (Drive Rated Amps x 2)  
**Default:** 0.0 (Disabled)  
**See also:** N/A

Enables/disables a software instantaneous (within 100 ms) current trip.

---

**A099 Process Factor (Display Scaling)**

**Range:** 0.1 to 999.9  
**Default:** 30.0  
**See also:** d010

Scales the value displayed by Process Display (d010).

Output Frequency x Process Factor = Process Display

---

**A100 Fault Clear**

**Range:** 0 = Ready/Idle  
1 = Reset Fault  
2 = Clear Buffer (d007 - d009 [Fault x Code])  
**Default:** 0 = Ready  
**See also:** d007 - d009

**1 = Reset Fault:** Clears the active fault and resets the drive.

**2 = Clear Buffer:** Clears fault codes from parameters d007 through d009.

---

**A101 Program Lock**

**Range:** 0 = Unlocked  
1 = Locked  
**Default:** 0 = Unlocked  
**See also:** N/A

Protects parameters against change by unauthorized personnel.

---

### A102 Testpoint Select

**Range:** 0400 to FFFF  
**Default:** 0400  
**See also:** d019

Used by Rockwell Automation field service personnel.

---

### A103 Comm Data Rate

**Range:** 0 = 1200  
1 = 2400  
2 = 4800  
3 = 9600  
4 = 19.2 K  
5 = 38.4 K  
**Default:** 4 = 19.2 K  
**See also:** N/A

Sets the serial port rate for the RS485 port.

**Important:** Cycle power after changing this parameter for the value to take effect.

---

### A104 Comm Node Address

**Range:** 1 to 247  
**Default:** 1  
**See also:** N/A

Sets the drive node address for the RS485 port if using a network connection.

**Important:** Cycle power after changing this parameter for the value to take effect.

---

### A105 Comm Loss Action

**Range:** 0 = Fault  
1 = Coast to Stop  
2 = Stop  
3 = Continue Last Speed  
**Default:** 0 = Fault  
**See also:** d015, P037, A106

Selects the drive's response to a loss of the communication connection or excessive communication errors.

**0 = Fault (Default):** Drive will fault on an F81 Comm Loss and coast to stop.

**1 = Coast to Stop:** Stops the drive via coast to stop.

**2 = Stop:** Stops the drive via the setting in Stop Mode (P037).

**3 = Continue Last Speed:** Drive continues operating at communication commanded speed saved in RAM.

---

### A106 Comm Loss Time

**Range:** 0.1 to 60.0

**Default:** 5.0

**See also:** d015, A105

Sets the time that the drive will remain in communication loss before implementing the option selected in Comm Loss Action (A105).

---

### A107 Comm Format

**Range:** 0 = RTU 8-N-1    3 = RTU 8-N-2  
1 = RTU 8-E-1    4 = RTU 8-E-2  
2 = RTU 8-O-1    5 = RTU 8-O-2

**Default:** 0 = RTU 8-N-1

**See also:** N/A

Determines details related to the specific RS485 protocol used by the drive.

**Important:** Cycle power after changing this parameter for the value to take effect.

## A110 0 - 10 V Analog Input Lo



**Range:** 0.0 to 100.0%  
**Default:** 0.0%  
**See also:** A111, d020

Sets the analog input level that corresponds to Minimum Freq. (P034) if a 0-10V input is used by Speed Reference (P038).

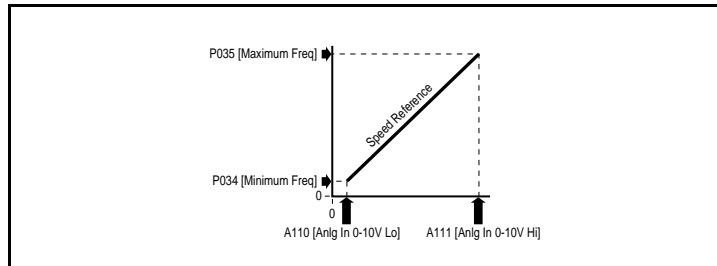

Analog inversion can be accomplished by setting this value larger than Anlg In 0-10V Hi (A111) or by setting Digital Inx Sel (A051-A052) to option 26 "Anlg Invert."

## A111 0 - 10 V Analog Input High



**Range:** 0.0 to 100.0%  
**Default:** 100.0%  
**See also:** A110, d020

Parameters A110 and A111 enable scaling of the 0 - 10 V analog input. The drive reaches maximum frequency at the voltage setting in parameter A111. The value is based on 10V. Therefore, to set the maximum frequency at 9 V, set A111 to 90%.

Use parameter d020 (0 - 10 V Analog Input) to verify the analog input signal.

Setting this parameter to a value less than 0 - 10 V Analog Input Low (A110) inverts the analog signal.

---

**A112 4 - 20 mA Analog Input Low**

**Range:** 0.0 to 100.0%  
**Default:** 0.0%  
**See also:** 113, d021

Parameters A112 and A113 enable scaling of the 4 - 20 mA analog input. The drive reaches minimum frequency at the current setting in parameter A112. The value is based on 4 - 20 mA. Therefore, to set the minimum frequency at 5.6 mA, set A112 to 10%.

Use parameter d021 (4 - 20 mA Analog Input) to verify the analog input signal.

Setting this parameter to a value greater than 4 - 20 mA Analog Input High (A113) inverts the analog signal.

---

**A113 4 - 20 mA Analog Input High**

**Range:** 0.0 to 100.0%  
**Default:** 100.0%  
**See also:** 112, d021

Parameters A112 and A113 enable scaling of the 4 - 20 mA analog input. The drive reaches maximum frequency at the current setting in parameter A113. The value is based on 4 - 20 mA. Therefore, to set the maximum frequency at 18.4 mA, set A112 to 90%.

Use parameter d021 (4 - 20 mA Analog Input) to verify the analog input signal.

Setting this parameter to a value less than 4 - 20 mA Analog Input Low (A112) inverts the analog signal.

---

**A114 Slip Compensation**

**Range:** 0.0 to 10.0 Hz  
**Default:** 2.0 Hz  
**See also:** N/A

Enables compensation for the inherent slip in an induction motor. If motor shaft speed decreases significantly under heavy loads, then increase the value of this parameter. Setting this parameter to 0.0 disables this function.

---

**A115 Process Time Lo**

**Range:** 0.0 to 99.99

**Default:** 0.00

**See also:** N/A

Scales the time value when the drive is running at Minimum Freq. (P034). When set to a value other than zero, Process Display (D010) indicates the duration of the process.

---

**A116 Process Time Hi**

**Range:** 0.0 to 99.99

**Default:** 0.00

**See also:** N/A

Scales the time value when the drive is running at Maximum Freq. (P035). When set to a value other than zero, Process Display (D010) indicates the duration of the process.

## 9.3 Display Group Parameters

---

### d001 Output Frequency

**Range:** 0.0 to Maximum Frequency  
**Default:** Read Only  
**See also:** d002, d010, P034, P035

The output frequency present at terminals T1, T2, and T3 (U, V, and W).

---

### d002 Commanded Frequency

**Range:** 0.0 to Maximum Frequency  
**Default:** Read Only  
**See also:** d001, P034, P035, P038

The value of the active frequency command. Displays the commanded frequency even if the drive is not running.

**Important:** The frequency command can come from a number of sources. Refer to section 6.5, Start and Speed Reference Control, for more information.

---

### d003 Output Current

**Range:** 0.00 to Drive Rated Amps x 2  
**Default:** Read Only  
**See also:** N/A

The output current present at terminals T1, T2, and T3 (U, V, and W).

---

### d004 Output Voltage

**Range:** 0 to Drive Rated Volts  
**Default:** Read Only  
**See also:** P031, A084, A088

The output voltage present at terminals T1, T2, and T3 (U, V, and W).

---

**d005 DC Bus Voltage**

**Range:** Based on Drive Rating  
**Default:** Read Only  
**See also:** N/A

The present DC bus voltage level.

---

**d006 Drive Status**

**Range:** 0 = Condition False  
1 = Condition True  
See figure 9.10  
**Default:** Read Only  
**See also:** A095

The present operating status of the drive.

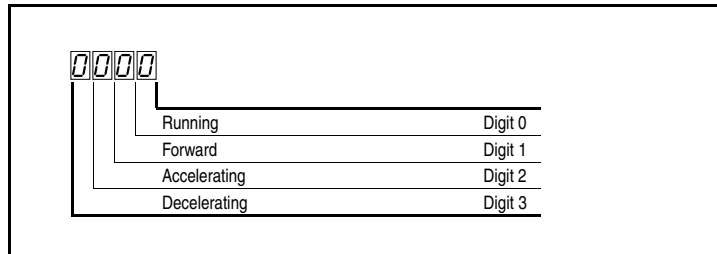

Figure 9.10 – Drive Status (d006) Bit Definitions

---

**d007 Fault 1 Code****d008 Fault 2 Code****d009 Fault 3 Code**

**Range:** F2 to F122  
**Default:** Read Only  
**See also:** N/A

A code that represents a drive fault. The codes will appear in these parameters in the order they occur (that is, Fault 1 Code in d007 will contain the more recent fault). Repetitive faults will be recorded only once. Refer to chapter 10 for the fault code descriptions.

## d010 Process Display

32

**Range:** 0.00 to 99999

**Default:** Read Only

**See also:** d001, A099

The output frequency scaled by A099 (Process Factor).

Output Frequency x Process Factor = Process Display

## d012 Control Source

**Range:** 0 to 9  
See figure 9.11.

**Default:** Read Only

**See also:** P036, P038, A051, A052

Displays the active source of the Start Command and Speed Reference, which are normally defined by the settings of P036 (Start Source) and P038 (Speed Reference), but may be overridden by digital inputs. Refer to the flowcharts in section 6.6 and 6.7 for details.

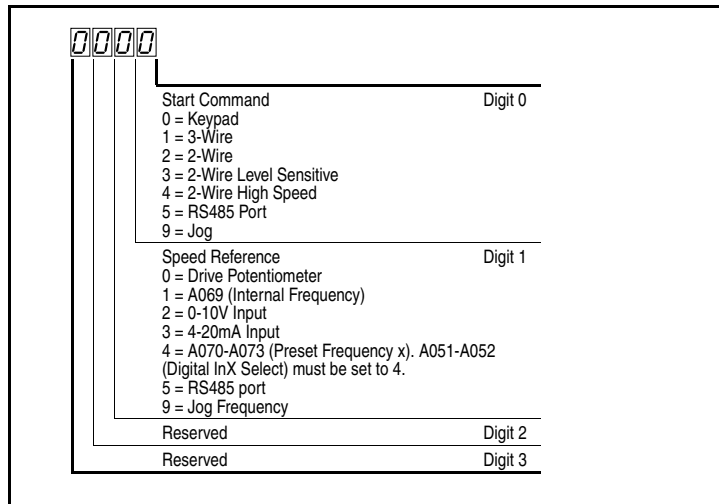

Figure 9.11 – Control Source (d012) Bit Definitions

### d013 Control Input Status

**Range:** 0 = Input Present  
1 = Input Not Present  
See figure 9.12

**Default:** Read Only

**See also:** N/A

The status of the control terminal block control inputs.

**Important:** Actual command may come from a source other than the control terminal block.

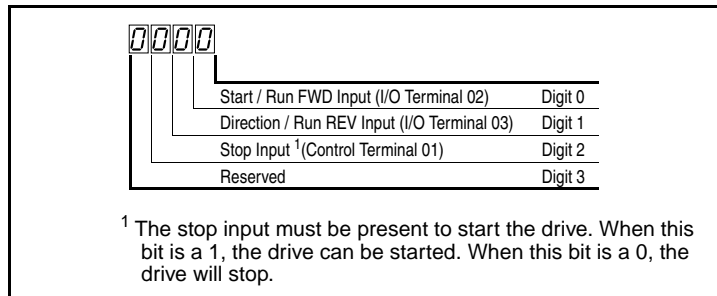

Figure 9.12 – Control Input Status (d013) Bit Definitions

### d014 Digital Input Status

**Range:** 0 = Input Not Present  
1 = Input Present  
See figure 9.13.

**Default:** Read Only

**See also:** A051, A052

The status of the control terminal block digital inputs.

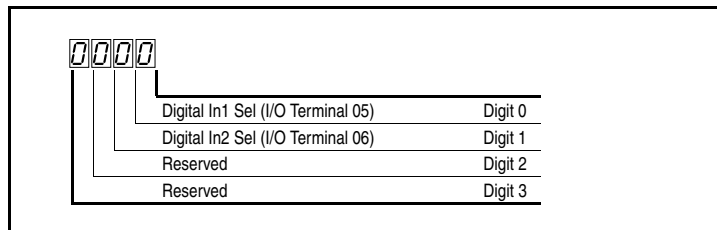

Figure 9.13 – Digital Input Status (d014) Bit Definitions

---

**d015 Comm Status**

**Range:** 0 = Condition False  
1 = Condition True  
See figure 9.14.  
**Default:** Read Only  
**See also:** A103 through A107

The status of the communications device.

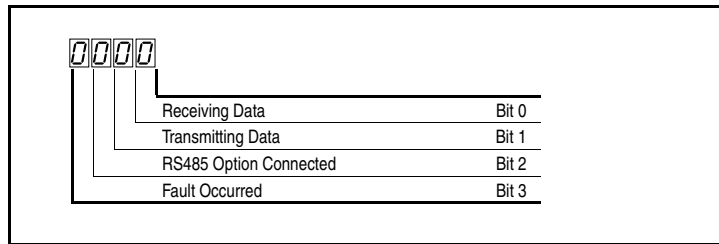

Figure 9.14 – Comm Status (d015) Bit Definitions

---

**d016 Control SW Version**

**Range:** 1.00 to 99.99  
**Default:** Read Only  
**See also:** N/A

The Main Control Board software version.

---

**d017 Drive Type**

**Range:** 1001 to 9999  
**Default:** Read Only  
**See also:** N/A

Used by Rockwell Automation field service personnel.

---

**d018 Elapsed Run Time**

**Range:** 0 to 9999 Hours  
**Default:** Read Only  
**See also:** N/A

The accumulated time drive is outputting power. The time is displayed in 10-hour increments (that is, 1 = 10 hours).

---

**d019 Testpoint Data**

**Range:** 0 to FFFF  
**Default:** Read Only  
**See also:** A102

The present value of the function selected in Testpoint Select (A102).

---

**d020 0 - 10 V Analog Input**

**Range:** 0.0 to 100.0%  
**Default:** Read Only  
**See also:** A110, A111

The value present at the drive's 0 - 10 V analog input.

---

**d021 4 to 20 mA Analog Input**

**Range:** 0.0 to 100.0%  
**Default:** Read Only  
**See also:** A112, A113

The value present at the drive's 4 - 20 mA analog input.

---

**d024 Drive Temp**

**Range:** 0 to 120<sup>0</sup> C  
**Default:** Read Only  
**See also:** N/A

Displays the present operating temperature of the drive power section.

# CHAPTER 10

## Troubleshooting the Drive



**ATTENTION:** The drive contains high voltage capacitors that take time to discharge after removal of mains supply. Before working on the drive, ensure isolation of mains supply from line inputs [R, S, T (L1, L2, L3)]. Wait three (3) minutes for capacitors to discharge to safe voltage levels. Darkened display LEDs is not an indication that capacitors have discharged to safe voltage levels. Failure to observe this precaution could result in severe bodily injury or loss of life.

**ATTENTION:** Only qualified electrical personnel familiar with the construction and operation of this equipment and the hazards involved should install, adjust, operate, or service this equipment. Read and understand this manual and other applicable manuals in their entirety before proceeding. Failure to observe this precaution could result in severe bodily injury or loss of life.

The MD60 constantly monitors its status and provides the following ways to determine the status of the drive and to troubleshoot problems that may occur:

- LEDs on the drive (refer to figure 8.1 and table 8.1 for a description of the LEDs)
- Fault codes

### 10.1 Fault Codes

Faults codes indicate conditions within the drive that require immediate attention. The drive responds to a fault by initiating a coast-to-stop sequence and turning off output power to the motor.

The integral keypad provides visual notification of a fault condition by displaying the following:

- Flashing fault number (code) on the display. (See table 10.1 for the fault code descriptions.)
- Flashing FAULT LED

In addition, parameters d007-d009 act as a fault log. See the parameter descriptions in chapter 9 for more information.

## 10.1.1 Manually Clearing Faults

- Step 1. Note the number of the fault code flashing on the display.
- Step 2. Press  on the integral keypad to acknowledge the fault and remove the fault code from the display. This also resets the drive if the fault is cleared.
- Step 3. Address the condition that caused the fault. Refer to table 10.1 for a description of the fault and corrective actions. The cause must be corrected before the fault can be cleared.
- Step 4. After corrective action has been taken, clear the fault and reset the drive using one of the following methods:
  - Press  if P037 (Stop Mode) is set to a value between 0 and 3.
  - Cycle drive power.
  - Set A100 (Fault Clear) to 1.
  - Cycle digital input if A051-A052 (Digital Inx Select) is set to option 7 (Clear Faults).

## 10.1.2 Automatically Clearing Faults (Auto Restart Feature)

The Auto Restart feature provides the ability for the drive to automatically perform a fault reset followed by a start attempt without user or application intervention. This allows remote or “unattended” operation. This feature can only be used for auto-resettable faults (see table 10.1).

When this type of fault occurs, and A092 (Auto Restart Tries) is set to a value greater than “0,” a user-configurable timer, A093 (Auto Restart Delay), begins. When the timer reaches zero, the drive attempts to automatically reset the fault. If the condition that caused the fault is no longer present, the fault will be reset and the drive will be restarted.

### **To automatically clear an auto-resettable fault and restart the drive:**

- Step 1. Set A092 (Auto Restart Tries) to a value other than 0.
- Step 2. Set A093 (Auto Restart Delay) to a value other than 0.

### **To automatically clear an OverVoltage, UnderVoltage, or Heatsink OverTemp fault without restarting the drive:**

- Step 1. Set A092 (Auto Restart Tries) to a value other than 0.
- Step 2. Set A093 (Auto Restart Delay) to 0.

Use caution when enabling this feature since the drive will attempt to issue its own start command based on user-selected programming.

Table 10.1 – Fault Descriptions and Corrective Actions

No.	Fault	Auto-Reset <sup>1</sup> ?	Description	Action
F2	Auxiliary Input	Y	Auxiliary input interlock is open.	<ul style="list-style-type: none"> <li>• Check remote wiring.</li> <li>• Verify communications programming for intentional fault.</li> </ul>
F3	Power Loss	N	DC bus voltage remained below 85% of nominal.	<ul style="list-style-type: none"> <li>• Monitor the incoming AC line for low voltage or line power interruption.</li> <li>• Check input fuses.</li> </ul>
F4	UnderVoltage	Y	DC bus voltage fell below the minimum value.	Monitor the incoming AC line for low voltage or line power interruption.
F5	OverVoltage	Y	DC bus voltage exceeded maximum value.	Monitor the AC line for high line voltage or transient conditions. Bus overvoltage can also be caused by motor regeneration. Extend the decel time or install dynamic brake option.
F6	Motor Stalled	Y	Drive is unable to accelerate motor.	Increase Accel Time x (P039, A067) or reduce load so drive output current does not exceed the current set by parameter A089 (Current Limit).
F7	Motor Overload	Y	Internal electronic overload trip.	<ul style="list-style-type: none"> <li>• An excessive motor load exists. Reduce load so drive output current does not exceed the current set by parameter P033 (Motor OL Current).</li> <li>• Verify Start Boost (A084) setting.</li> </ul>

Table 10.1 – Fault Descriptions and Corrective Actions (Continued)

No.	Fault	Auto-Reset?	Description	Action
F8	Heatsink OverTemp	Y	Heatsink temperature exceeds a predefined value.	<ul style="list-style-type: none"> <li>• Check for blocked or dirty heat sink fins. Verify that ambient temperature has not exceeded 40°C (104°F) for IP 30/NEMA 1/UL Type 1 installations or 50°C (122°F) for Open type installations.</li> <li>• Check fan.</li> </ul>
F12	HW OverCurrent	N	The drive output current has exceeded the hardware current limit.	Check programming. Check for excess load, improper Start Boost (A084) setting, DC brake volts set too high, or other causes of excess current.
F13	Ground Fault	N	A current path to earth ground has been detected at one or more of the drive output terminals.	Check the motor and external wiring to the drive output terminals for a grounded condition.
F33	Auto Restart Tries	N	Drive unsuccessfully attempted to reset a fault and resume running for the programmed number of Auto Restart Tries in A092.	Correct the cause of the fault and manually clear.
F38	Phase U to Gnd	N	A phase to ground fault has been detected between the drive and motor in this phase.	<ul style="list-style-type: none"> <li>• Check the wiring between the drive and motor.</li> <li>• Check motor for grounded phase.</li> <li>• Replace drive if fault cannot be cleared.</li> </ul>
F39	Phase V to Gnd			
F40	Phase W to Gnd			
F41	Phase UV Short	N	Excessive current has been detected between these two output terminals.	<ul style="list-style-type: none"> <li>• Check the motor and drive output terminal wiring for a shorted condition.</li> <li>• Replace drive if fault cannot be cleared.</li> </ul>
F42	Phase UW Short			
F43	Phase VW Short			

Table 10.1 – Fault Descriptions and Corrective Actions (Continued)

No.	Fault	Auto-Reset <sup>1</sup> ?	Description	Action
F48	Params Defaulted	N	The drive was commanded to write default values to EEPROM.	<ul style="list-style-type: none"> <li>• Clear the fault or cycle power to the drive.</li> <li>• Program the drive parameters as needed.</li> </ul>
F63	SW OverCurrent	Y	Programmed A098 (SW Current Trip) has been exceeded.	Check load requirements and A098 (SW Current Trip) setting.
F64	Drive Overload	N	Drive rating of 150% for 1 minute has been exceeded.	Reduce load or extend Accel Time.
F70	Power Unit	N	Failure has been detected in the drive power section.	<ul style="list-style-type: none"> <li>• Cycle power.</li> <li>• Replace drive if fault cannot be cleared.</li> </ul>
F81	Comm Loss	N	RS485 port stopped communicating.	<ul style="list-style-type: none"> <li>• If module was not intentionally disconnected, check wiring to the port. Replace wiring, port expander, module or complete drive as required.</li> <li>• Check connection.</li> <li>• A module was intentionally disconnected.</li> <li>• Turn off using A105 (Comm Loss Action).</li> </ul>
F100	Parameter Checksum	N	The checksum read from the board does not match the checksum calculated.	Set P041 (Reset to Defaults) to option 1 (Reset Defaults).
F122	I/O Board Fail	N	Failure has been detected in the drive control and I/O section.	<ul style="list-style-type: none"> <li>• Cycle power.</li> <li>• Replace drive if fault cannot be cleared.</li> </ul>

<sup>1</sup> Refer to section 10.1.2 for information about the Auto Restart Feature.

## 10.2 Troubleshooting Tables

Use the following tables to troubleshoot the drive. If you cannot resolve the problem using these tables, contact Reliance Electric.

### 10.2.1 Problem: Drive Does Not Start From Terminal Block Start or Run Inputs

Table 10.2 – Problem: Drive Does Not Start From Terminal Block Start or Run Inputs

Possible Cause(s)	Indication	Corrective Action
Drive is faulted	Flashing red FAULT LED	Clear fault by using one of the following methods: <ul style="list-style-type: none"> <li>• Press Stop</li> <li>• Cycle power</li> <li>• Set A100 (Fault Clear) to 1 (Clear Faults)</li> <li>• Cycle digital input if A051/A052 (Digital Inx Select) is set to option 7 (Clear Fault).</li> </ul>
Incorrect programming. <ul style="list-style-type: none"> <li>• P036 (Start Source) is set to option 0 (Keypad) or option 5 (RS485 Port).</li> <li>• A051/A052 (Digital Inx Select) is set to option 5 “Local” and the input is active.</li> </ul>	None	Check parameter settings.
Incorrect input wiring. See figure 6.2 for wiring examples. <ul style="list-style-type: none"> <li>• 2-wire control requires Run Forward, Run Reverse or Jog input.</li> <li>• 3-wire control requires Start and Stop inputs</li> <li>• Stop input is always required.</li> </ul>	None	Wire inputs correctly and/or install jumper.

## 10.2.2 Problem: Drive Does Not Start From Integral Keypad

Table 10.3 – Problem: Drive Does Not Start From Integral Keypad

Cause(s)	Indication	Corrective Action
Integral keypad is not enabled.	Start Key Status LED is not on.	<ul style="list-style-type: none"> <li>Set parameter P036 (Start Source) to option 0 (Keypad).</li> <li>Set parameter A051/A052 (Digital Inx Select) is set to option 5 (Local) and activate the input.</li> </ul>
I/O Terminal 01 “Stop” input is not present.	None	Wire inputs correctly and/or install jumper.

## 10.2.3 Problem: Drive Does Not Respond to Changes in Speed Command

Table 10.4 – Problem: Drive Does Not Respond to Changes in Speed Command

Cause(s)	Indication	Corrective Action
No value is coming from the source of the command.	The RUN LED is on and output is 0 Hz.	<ul style="list-style-type: none"> <li>Check d012 (Control Source) for correct source.</li> <li>If the source is an analog input, check wiring and use a meter to check for presence of signal.</li> <li>Check d002 (Commanded Frequency) to verify correct command.</li> </ul>
Incorrect reference source is being selected via remote device or digital inputs.	None	<ul style="list-style-type: none"> <li>Check d012 (Control Source) for correct source.</li> <li>Check d014 (Digital Input Status) to see if inputs are selecting an alternate source. Verify settings for A051/A052 (Digital Inx Select).</li> <li>Check P038 (Speed Reference) for the source of the speed reference. Reprogram as necessary.</li> <li>Review the Speed Reference Control chart in section 6.6.</li> </ul>

## 10.2.4 Problem: Motor and/or Drive Will Not Accelerate to Commanded Speed

Table 10.5 – Problem: Motor and/or Drive Will Not Accelerate to Commanded Speed

Cause(s)	Indication	Corrective Action
Acceleration time is excessive.	None	Reprogram P039 (Accel Time 1) or A067 (Accel Time 2).
Excess load or short acceleration times force the drive into current limit, slowing or stopping acceleration.	None	<ul style="list-style-type: none"> <li>• Compare d003 (Output Current) with A089 (Current Limit).</li> <li>• Remove excess load or reprogram P039 (Accel Time 1) or A067 (Accel Time 2).</li> <li>• Check for improper A084 (Start Boost) setting.</li> </ul>
Speed command source or value is not as expected.	None	<ul style="list-style-type: none"> <li>• Verify d002 (Commanded Frequency).</li> <li>• Check d012 (Control Source) for the proper Speed Command.</li> </ul>
Programming is preventing the drive output from exceeding limiting values.	None	Check P035 (Maximum Frequency) to ensure that speed is not limited by programming.

## 10.2.5 Problem: Motor Operation is Unstable

Table 10.6 – Problem: Motor Operation is Unstable

Cause(s)	Indication	Corrective Action
Motor data was incorrectly entered.	None	<ol style="list-style-type: none"> <li>1. Correctly enter motor nameplate data into P031, P032 and P033.</li> <li>2. Enable A097 (Compensation).</li> <li>3. Use A084 (Start Boost) to reduce boost level.</li> </ol>

## 10.2.6 Problem: Drive Will Not Reverse Motor Direction.

Table 10.7 – Problem: Drive Will Not Reverse Motor Direction

Cause(s)	Indication	Corrective Action
Digital input is not selected for reversing control.	None	Check (Digital Inx Select). Choose correct input and program for reversing mode.
Digital input is incorrectly wired.	None	Check input wiring.
Motor wiring is improperly phased for reverse.	None	Switch two motor leads.
Reverse is disabled.	None	Check A095 (Reverse Disable).



# APPENDIX A

## Technical Specifications

<b>Environment</b>	
Altitude:	1000 m (3300 ft) maximum without derating
Ambient Operating Temperature Without Derating:	IP 20: -10° C (14° F) to 50° C (122° F) NEMA 1/IP30: -10° C (14° F) to 40° C (104° F)
Storage Temperature (all const.):	-40° C (-40° F) to 85° C (185° F)
Relative Humidity:	0% to 95%, non-condensing
Shock (Operating):	15 G peak for 11 ms duration (+/-1.0 ms)
Vibration (Operating):	1 G peak, 5 to 2000 Hz
<b>Control</b>	
Carrier Frequency:	2-16 kHz. Drive rating based on 4 kHz.
Frequency Accuracy	<ul style="list-style-type: none"><li>• Digital Input: Within +/-0.05% of set output frequency.</li><li>• Analog Input: Within 0.5% of maximum output frequency.</li></ul>
Speed Regulation - Open Loop with Slip Compensation:	+/-2% of base speed across a 40:1 speed range.
Stop Modes:	Multiple programmable stop modes including: Ramp, Coast, DC-Brake, Ramp-to-Hold, and S Curve.
Accel/Decel:	Two independently programmable accel and decel times. Each time may be programmed from 0-600 seconds in 0.1 second increments.
Intermittent Overload	<ul style="list-style-type: none"><li>• 150% Overload capability for up to 1 minute.</li><li>• 200% Overload capacity for up to 3 seconds</li></ul>
Electronic Motor Overload Protection:	Class 10 protection with speed-sensitive response.

<b>Input/Output Rating</b>	
Output Frequency:	0-240 Hz (Programmable)
Efficiency:	97.5% (Typical)
<b>Digital Control Inputs (Inputs Current = 6 mA)</b>	
SRC (Source) Mode:	18-24 V = ON 0-6 V = OFF
SNK (Sink) Mode:	0-6 V = ON 18-24 V = OFF
<b>Analog Control Inputs</b>	
4-20 mA Analog:	250 ohm input impedance
0-10 V DC Analog:	100k ohm input impedance
External Pot:	1-10 k ohms, 2 Watt minimum
<b>Control Output</b>	
Programmable Output (form C relay)	
Resistive Rating:	3.0 A at 30 V DC, 3.0 A at 125 V AC, 3.0 A at 240 V AC
Inductive Rating:	0.5 A at 30 V DC, 0.5 A at 125 V AC, 0.5 A at 240 V AC
<b>Fuses and Circuit Breakers</b>	
Recommended Fuse Type:	UL Class J, CC, T or Type BS88; 600 V (550 V) or equivalent.
Recommended Circuit Breakers:	HMCP circuit breakers or equivalent.
<b>Protective Features</b>	
Motor Protection:	I <sup>2</sup> t overload protection - 150% for 60 sec, 200% for 3 sec (Provides Class 10 protection)
Overcurrent:	200% hardware limit, 300% instantaneous fault
Over Voltage:	<ul style="list-style-type: none"> <li>• 100-120 V AC Input – Trip occurs at 405 V DC bus voltage (equivalent to 150 V AC incoming line)</li> <li>• 200-240 V AC Input – Trip occurs at 405 V DC bus voltage (equivalent to 290 V AC incoming line)</li> <li>• 380-460 V AC Input – Trip occurs at 810 V DC bus voltage (equivalent to 575 V AC incoming line)</li> </ul>

Under Voltage:	<ul style="list-style-type: none"> <li>• 100-120 V AC Input – Trip occurs at 210 V DC bus voltage (equivalent to 75 V AC incoming line)</li> <li>• 200-240 V AC Input – Trip occurs at 210 V DC bus voltage (equivalent to 150 V AC incoming line)</li> <li>• 380-480 V AC Input – Trip occurs at 390 V DC bus voltage (equivalent to 275 V AC incoming line)</li> </ul>
Control Ride-Through:	Minimum ride-through is 0.5 sec - typical value 2 sec
Faultless Power Ride-Through:	100 milliseconds
<b>Dynamic Braking</b>	
Internal brake IGBT included with all ratings.	
<b>Approvals</b>	
 <p>UL UL508C    UL CSA 22.2    ✓</p> <p>CE EMC Directive 89/336  LV: EN 50178, EN 60204  EMC: EN 61800-3, EN 50081-1, EN 50082-2</p>	



# APPENDIX B

## Record of User Settings

### B.1 Basic Parameter Group

No.	Parameter Name	Default Value	Page No.	User Setting
P031	Motor NP Volts	Varies	9-2	
P032	Motor NP Hertz	60 Hz	9-2	
P033	Motor OL Current	Varies	9-2	
P034	Minimum Frequency	0 Hz	9-2	
P035	Maximum Frequency	60 Hz	9-2	
P036	Start Source	0 = Keypad	9-3	
P037	Stop Mode	1 = Coast, Clear Fault	9-5	
P038	Speed Reference	0 = Drive Potentiometer	9-6	
P039	Accel Time 1	5.0 sec	9-7	
P040	Decel Time 1	5.0 sec	9-7	
P041	Reset to Defaults	0 = Idle State	9-7	

## B.2 Advanced Parameter Group

No.	Parameter Name	Default Value	Page No.	User Setting
A051	Digital In1 Select	4 = Preset Frequencies	9-8	
A052	Digital In2 Select	4 = Preset Frequencies	9-8	
A055	Relay Output Select	0 = Ready (Not Faulted)	9-9	
A056	Relay Output Level	0.0	9-11	
A067	Accel Time 2	10.0 sec	9-11	
A068	Decel Time 2	10.0 sec	9-12	
A069	Internal Frequency	0.0 Hz	9-12	
A070	Preset Frequency 0	0.0 Hz	9-13	
A071	Preset Frequency 1	0.0 Hz	9-13	
A072	Preset Frequency 2	0.0 Hz	9-13	
A073	Preset Frequency 3	0.0 Hz	9-13	
A078	Jog Frequency	10.0 Hz	9-13	
A079	Jog Accel/Decel	10.0 sec	9-13	
A080	DC Brake Time	0.0 sec	9-14	
A081	DC Brake Level	Amps x 0.5	9-14	
A082	DB Resistor Select	0 = Disabled	9-15	
A083	S Curve%	0% (Disabled)	9-15	
A084	Start Boost	8 = 5.0	9-16	
A088	Maximum Voltage	Rated Volts	9-17	
A089	Current Limit	Amps x 1.8	9-17	
A090	Motor OL Select	0 = No Derate	9-17	
A091	PWM Frequency	4.0 kHz	9-18	
A092	Auto Restart Tries	0	9-18	
A093	Auto Restart Delay	1.0 sec	9-19	
A094	Start At Power Up	0 = Disabled	9-19	
A095	Reverse Disable	0 = Reverse Enabled	9-19	
A096	Flying Start Enable	0 = Disabled	9-20	
A097	Compensation	1 = Electrical	9-20	
A098	SW Current Trip	0.0 (Disabled)	9-21	
A099	Process Factor (Display Scaling)	30.0	9-21	

<b>No.</b>	<b>Parameter Name</b>	<b>Default Value</b>	<b>Page No.</b>	<b>User Setting</b>
A100	Fault Clear	0 = Ready	9-21	
A101	Program Lock	0 = Unlocked	9-21	
A102	Testpoint Select	0000	9-22	
A103	Comm Data Rate	4 = 19.2 K	9-22	
A104	Comm Node Address	1	9-22	
A105	Comm Loss Action	0 = Fault	9-22	
A106	Comm Loss Time	5.0	9-23	
A107	Comm Format	0 = RTU 8-N-1	9-23	
A110	0 - 10 V Analog Input Low	0.0%	9-24	
A111	0 - 10 V Analog Input High	100.0%	9-24	
A112	4 - 20 mA Analog Input Low	0.0%	9-25	
A113	4 - 20 mA Analog Input High	100.0%	9-25	
A114	Slip Compensation	2.0 Hz	9-25	
A115	Process Time Lo	0.00	9-26	
A116	Process Time Hi	0.00	9-26	



# APPENDIX C

## Parameters Cross-Referenced by Name

Parameter Name	No.	Parameter Group	Default Value	Page No.
0 - 10 V Analog Input	d020	Display	Read Only	9-32
0 - 10 V Analog Input High	A111	Advanced	100.0%	9-24
0 - 10 V Analog Input Low	A110	Advanced	0.0%	9-24
4 - 20 mA Analog Input	d021	Display	Read Only	9-32
4 - 20 mA Analog Input High	A113	Advanced	100.0%	9-25
4 - 20 mA Analog Input Low	A112	Advanced	0.0%	9-25
Accel Time 1	P039	Basic	5.0 sec	9-7
Accel Time 2	A067	Advanced	10.0 sec	9-11
Auto Restart Delay	A093	Advanced	1.0 sec	9-19
Auto Restart Tries	A092	Advanced	0	9-18
Comm Data Rate	A103	Advanced	4 = 19.2 K	9-22
Comm Format	A107	Advanced	0 = RTU 8-N-1	9-23
Comm Loss Action	A105	Advanced	0 = Fault	9-22
Comm Loss Time	A106	Advanced	5.0	9-23
Comm Node Address	A104	Advanced	1	9-22
Comm Status	d015	Display	Read Only	9-31
Commanded Frequency	d002	Display	Read Only	9-27
Compensation	A097	Advanced	1 = Electrical	9-20
Control Input Status	d013	Display	Read Only	9-30
Control Source	d012	Display	Read Only	9-29
Control SW Version	d016	Display	Read Only	9-31
Current Limit	A089	Advanced	Amps x 1.8	9-17

Parameter Name	No.	Parameter Group	Default Value	Page No.
DB Resistor Select	A082	Advanced	0 = Disabled	9-15
DC Brake Level	A081	Advanced	Amps x 0.5	9-14
DC Brake Time	A080	Advanced	0.0 sec	9-14
DC Bus Voltage	d005	Display	Read Only	9-28
Decel Time 1	P040	Basic	5.0 sec	9-7
Decel Time 2	A068	Advanced	10.0 sec	9-12
Digital Input Status	d014	Display	Read Only	9-30
Digital In1 Select	A051	Advanced	4 = Preset Frequencies	9-8
Digital In2 Select	A052	Advanced	4 = Preset Frequencies	9-8
Drive Status	d006	Display	Read Only	9-28
Drive Temp	d024	Display	Read Only	9-32
Drive Type	d017	Display	Read Only	9-31
Elapsed Run Time	d018	Display	Read Only	9-31
Fault 1 Code	d007	Display	Read Only	9-28
Fault 2 Code	d008	Display	Read Only	9-28
Fault 3 Code	d009	Display	Read Only	9-28
Fault Clear	A100	Advanced	0 = Ready	9-21
Flying Start Enable	A096	Advanced	0 = Disabled	9-20
Internal Frequency	A069	Advanced	0.0 Hz	9-12
Jog Accel/Decel	A079	Advanced	10.0 sec	9-13
Jog Frequency	A078	Advanced	10.0 Hz	9-13
Maximum Frequency	P035	Basic	60 Hz	9-2
Maximum Voltage	A088	Advanced	Rated Volts	9-17
Minimum Frequency	P034	Basic	0 Hz	9-2
Motor NP Hertz	P032	Basic	60 Hz	9-2
Motor NP Volts	P031	Basic	Varies	9-2
Motor OL Current	P033	Basic	Varies	9-2
Motor OL Select	A090	Advanced	0 = No Derate	9-17
Output Current	d003	Display	Read Only	9-27
Output Frequency	d001	Display	Read Only	9-27
Output Voltage	d004	Display	Read Only	9-27
Preset Frequency 0	A070	Advanced	0.0 Hz	9-13
Preset Frequency 2	A072	Advanced	0.0 Hz	9-13
Preset Frequency 3	A073	Advanced	0.0 Hz	9-13

<b>Parameter Name</b>	<b>No.</b>	<b>Parameter Group</b>	<b>Default Value</b>	<b>Page No.</b>
Preset Frequency 1	A071	Advanced	0.0 Hz	9-13
Process Display	d010	Display	Read Only	9-29
Process Factor	A099	Advanced	30.0	9-21
Process Time Lo	A115	Advanced	0.00	9-26
Process Time Hi	A116	Advanced	0.00	9-26
Program Lock	A101	Advanced	0 = Unlocked	9-21
PWM Frequency	A091	Advanced	4.0 kHz	9-18
Relay Output Level	A056	Advanced	0.0	9-11
Relay Output Select	A055	Advanced	0 = Ready (Not Faulted)	9-9
Reset to Defaults	P041	Basic	0 = Idle State	9-7
Reverse Disable	A095	Advanced	0 = Reverse Enabled	9-19
S Curve%	A083	Advanced	0% (Disabled)	9-15
Slip Compensation	A114	Advanced	2.0 Hz	9-25
Speed Reference	P038	Basic	0 = Drive Potentiometer	9-6
Start At Power Up	A094	Advanced	0 = Disabled	9-19
Start Boost	A084	Advanced	8 = 5.0	9-16
Start Source	P036	Basic	0 = Keypad	9-3
Stop Mode	P037	Basic	1 = Coast, Clear Fault	9-5
SW Current Trip	A098	Advanced	0.0 (Disabled)	9-21
Testpoint Data	d019	Display	Read Only	9-32
Testpoint Select	A102	Advanced	0000	9-22



# APPENDIX D

---

## CE Conformance Requirements

Conformity with the Low Voltage (LV) Directive and Electromagnetic Compatibility (EMC) Directive has been demonstrated using harmonized European Norm (EN) standards published in the Official Journal of the European Communities. The MD60 AC drive complies with the EN standards listed below when installed according to the User Manual.

CE Declarations of Conformity are available online at:  
<http://www.reliance.com/certification/>.

### **Low Voltage Directive (73/23/EEC)**

- EN50178 Electronic equipment for use in power installations.

### **EMC Directive (89/336/EEC)**

- EN61800-3 (Second Environment) Adjustable speed electrical power drive systems Part 3: EMC product standard including specific test methods.

### **General Notes**

- If the top panel is removed or the optional conduit box is not installed, the drive must be installed in an enclosure with side openings less than 12.5 mm (0.5 in) and top openings less than 1.0 mm (0.04 in) to maintain compliance with the LV Directive. Refer to figure 3.1.
- The motor cable should be kept as short as possible in order to avoid electromagnetic emission as well as capacitive currents.
- The use of line filters in ungrounded systems is not recommended.
- Conformity of the drive with CE EMC requirements does not guarantee an entire machine installation complies with the CE EMC requirements. Many factors can influence total machine/installation compliance.

## Essential Requirements for CE Compliance

The following conditions **must be** satisfied for MD60 drives to meet the requirements of **EN61800-3**.

- Grounding as described in figure D.1. Refer to chapter for additional grounding recommendations.
- Output power, control (I/O) and signal wiring must be braided, shielded cable with a coverage of 75% or better, metal conduit or equivalent attenuation.
- Allowable cable length in table D.1 is not exceeded.

Table D.1 – Allowable Cable Length<sup>1</sup>

<b>Filter Type</b>	<b>EN61800-3 First Environment<sup>3</sup> Restricted Distribution or Second Environment</b>	<b>EN61800-3 First Environment Unrestricted Distribution<sup>4</sup></b>
Integral	5 meters (16 feet)	1 meter (3 feet)
External - Short <sup>2</sup>	5 meters (16 feet)	1 meter (3 feet)
External - Long <sup>2</sup>	100 meters (328 feet)	5 meters (16 feet)

<sup>1</sup> Testing of longer cable lengths is pending.

<sup>2</sup> Contact Reliance Electric for details on optional external filters.

<sup>3</sup> Equivalent to EN55011 Class A.

<sup>4</sup> Equivalent to EN55011 Class B.

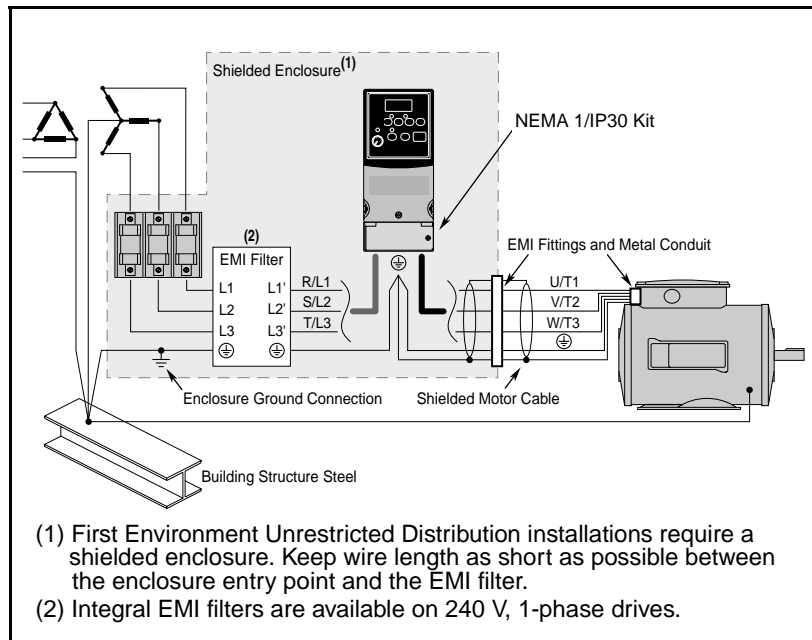

Figure D.1 – Connections and Grounding

### EN61000-3-2

- 0.75 kW (1 HP) 240 V 1-phase and 3-phase drives and 0.37 kW (1/2 HP) 240 V 1-phase drives are suitable for installation on a private low-voltage power network. Installations on a public low-voltage power network may require additional harmonic mitigation.
- Other drive ratings meet the current harmonic requirements of EN61000-3-2 without additional external mitigation.



# APPENDIX E

## Accessories

### E.1 Dynamic Brake Modules

Table E.1 – Dynamic Brake Modules

Drive Ratings				Minimum Resistance (ohms)	Model Number <sup>1</sup>
Input Voltage	kW	HP			
120V 50/60 Hz 1-Phase	0.2	0.25	-	-	AK-R2-091P500
	0.75	1.0	-	-	AK-R2-091P500
	0.75	1.0	60	60	AK-R2-091P500
	1.1	1.5	60	60	AK-R2-091P500
240V 50/60 Hz 1-Phase	0.2	0.25	-	-	AK-R2-091P500
	0.4	0.5	-	-	AK-R2-091P500
	0.75	1.0	60	60	AK-R2-091P500
	1.5	2.0	60	60	AK-R2-091P500
240V 50/60 Hz 3-Phase	0.2	0.25	-	-	AK-R2-091P500
	0.4	0.5	-	-	AK-R2-091P500
	0.75	1.0	60	60	AK-R2-091P500
	1.5	2.0	60	60	AK-R2-091P500
	2.2	3.0	48	48	AK-R2-047P500
	3.7	5.0	32	32	AK-R2-047P500
480V 50/60 Hz 3-Phase	0.4	0.5	-	-	AK-R2-360P500
	0.75	1.0	121	121	AK-R2-360P500
	1.5	2.0	121	121	AK-R2-360P500
	2.2	3.0	97	97	AK-R2-120P1K2
	3.7	5.0	97	97	AK-R2-120P1K2

<sup>1</sup> The resistors listed in this table are rated for 5% duty cycle.

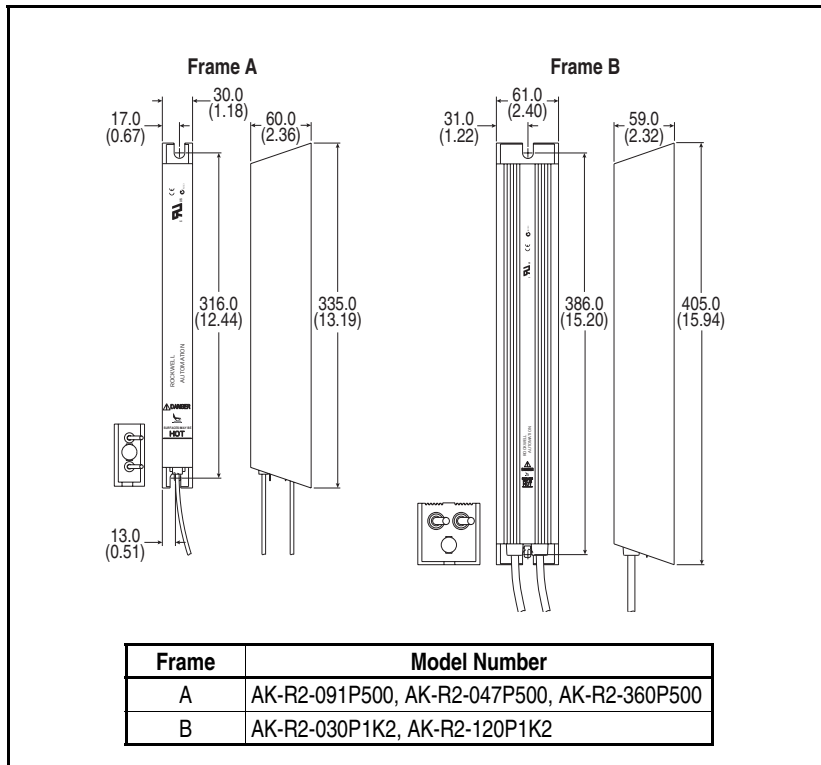

Figure E.1 – Dynamic Brake Modules: Dimensions

## E.2 EMC Line Filters

Table E.2 – EMC Line Filters

Drive Ratings			S Type Filter Model Number <sup>1</sup>	L Type Filter Model Number <sup>6</sup>
Input Voltage	kW	HP		
120V 50/60 Hz 1-Phase	0.2	0.25	–	6MDF-010AL
	0.4	0.5	–	6MDF-010AL
	0.75	1.0	–	6MDF-018BL
	1.1	1.5	–	6MDF-025CL
240V 50/60 Hz 1-Phase	0.2	0.25	<sup>2</sup>	6MDF-010AL
	0.4	0.5	<sup>3</sup>	6MDF-010AL
	0.75	1.0	<sup>2</sup>	6MDF-010AL
	1.5	2.0	<sup>2</sup>	6MDF-018BL
240V 50/60 Hz 3-Phase	0.2	0.25	6MDF-021BS <sup>4</sup>	6MDF-9P5AL
	0.4	0.5	6MDF-021BS <sup>5</sup>	6MDF-9P5AL
	0.75	1.0	6MDF-021BS <sup>3</sup>	6MDF-9P5AL
	1.5	2.0	6MDF-021BS <sup>3</sup>	6MDF-9P5AL
	2.2	3.0	6MDF-021BS <sup>3</sup>	6MDF-021BL
	3.7	5.0	6MDF-021BS <sup>3</sup>	6MDF-021BL
480V 50/60 Hz 3-Phase	0.4	0.5	6MDF-012BS	6MDF-5P7AL
	0.75	1.0	6MDF-012BS	6MDF-5P7AL
	1.5	2.0	6MDF-012BS	6MDF-5P7AL
	2.2	3.0	6MDF-012BS	6MDF-012BL
	3.7	5.0	6MDF-012BS	6MDF-012BL

<sup>1</sup> This filter is suitable for use with a cable length of at least 10 meters (33 feet) for Class A and 1 meter for Class B environments.

<sup>2</sup> These ratings can be ordered with internal “S Type” filters.

<sup>3</sup> These ratings can be ordered with internal “S Type” filters.

<sup>4</sup> Filter must be Series B.

<sup>5</sup> Filter must be Series B.

<sup>6</sup> This filter is suitable for use with a cable length of at least 100 meters for Class A and 5 meters for Class B environments.

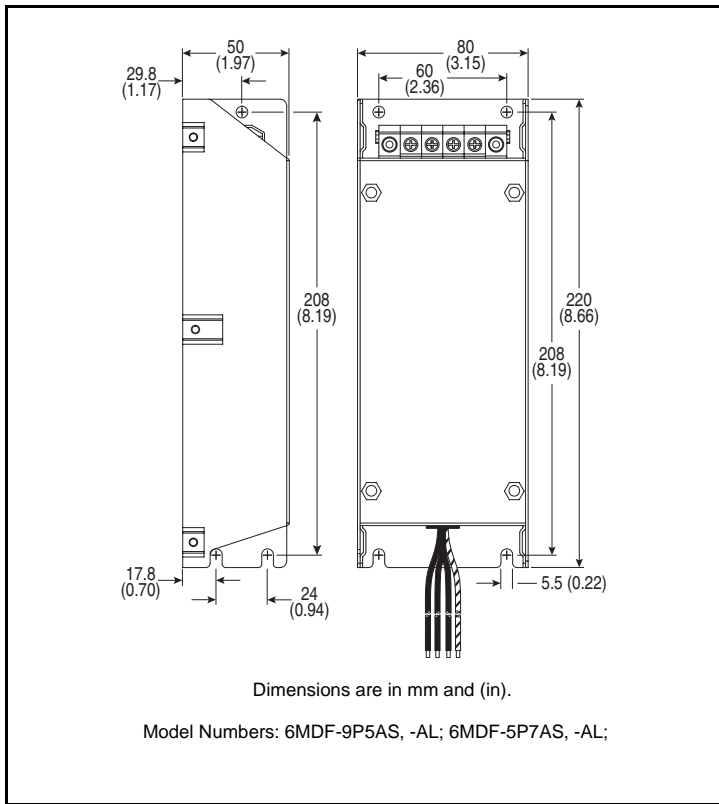

Figure E.2 – Frame A EMC Line Filters: Dimensions

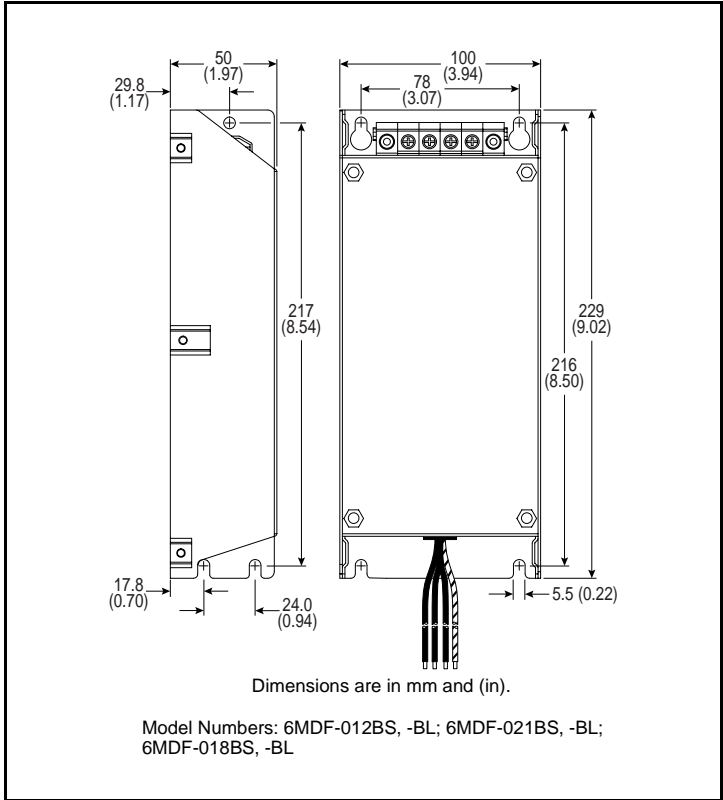

Figure E.3 – Frame B EMC Line Filters: Dimensions

## E.3 Operator Interface Modules (OIMs)

Table E.3 – Operator Interface Modules/Accessories

<b>Description</b>	<b>Model Number</b>
Remote Panel-Mount OIM (digital speed control, CopyCat capable, IP66 (NEMA 4x12) indoor use only, includes 2.9 meter cable)	MD4ALCD
Remote Handheld OIM (digital speed control, full numeric keypad, CopyCat capable, IP30 (NEMA Type 1); includes 1.0 meter cable; panel-mount with optional Bezel Kit)	MD1CC
Bezel Kit (panel mount for Remote Handheld OIM)	MDBZL-N1
OIM Cable (1.0 meter OIM-to-RJ45 cable)	MDCBL-CC1
OIM Cable (2.9 meter OIM-to-RJ45 cable)	MDCBL-CC3

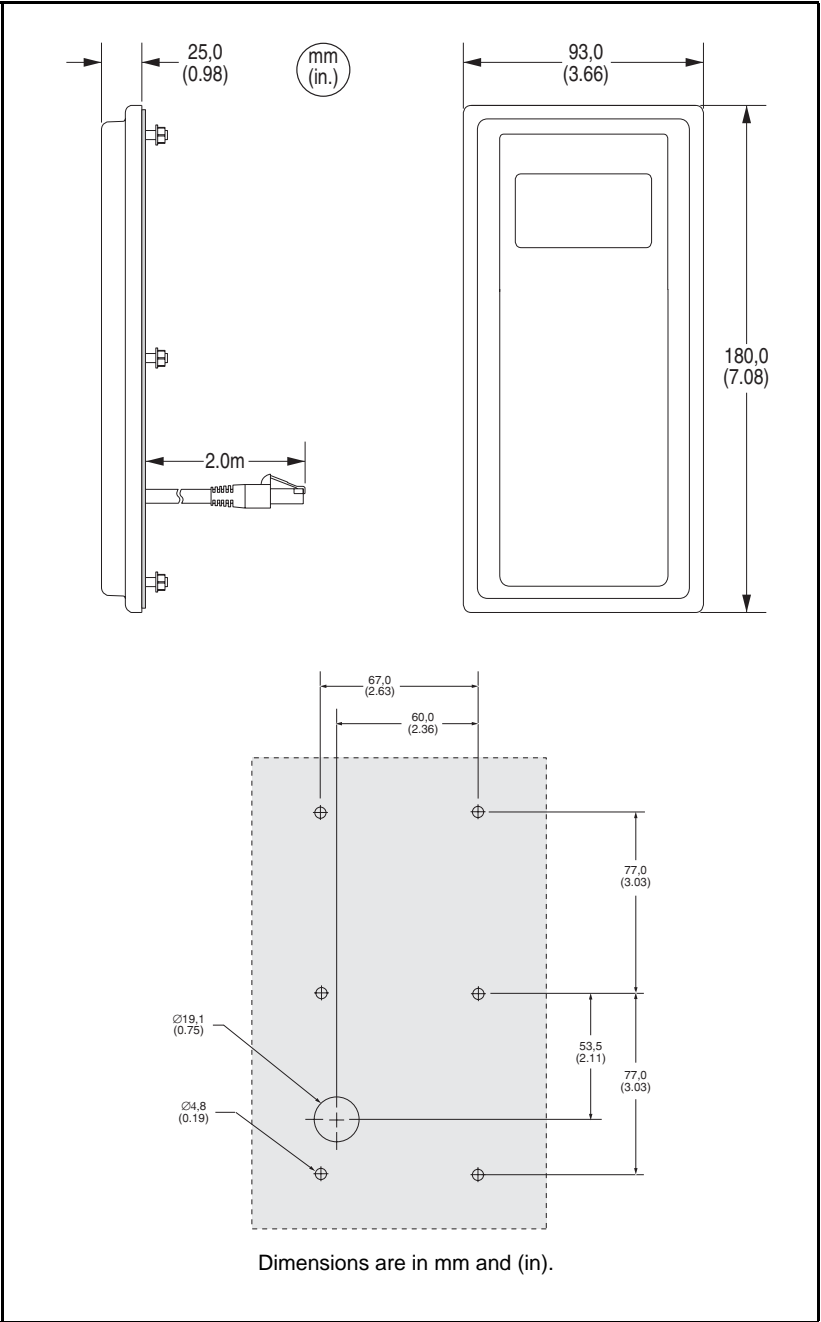

Figure E.4 – Remote OIM (M/N MD4ALCD)

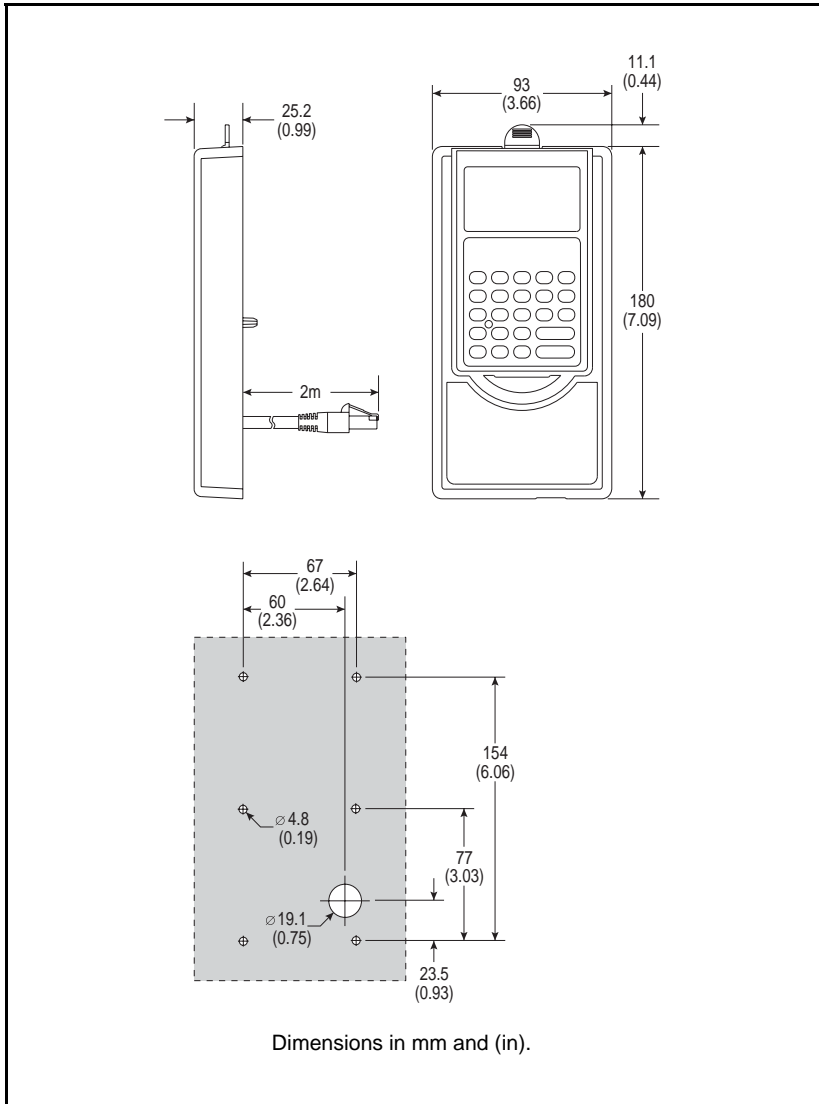

Figure E.5 – NEMA Type 1 Bezel (M/N MDBZL-N1): Dimensions

# APPENDIX F

## RS485 (MDI) Protocol

MD60 drives support the RS485 (MDI) protocol to allow efficient operation with Rockwell Automation peripherals. In addition, some Modbus functions are supported to allow simple networking. MD60 drives can be multi-dropped on an RS485 network using Modbus protocol in RTU mode.

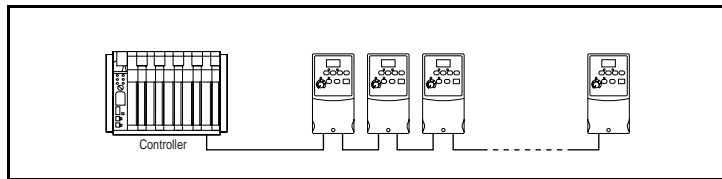

Figure F.1 – Sample Network

For information regarding DeviceNet or other communication protocols, refer to the appropriate user manual.

### Network Wiring

Network wiring consists of a shielded 2-conductor cable that is daisy-chained from node to node. See figure F.2.

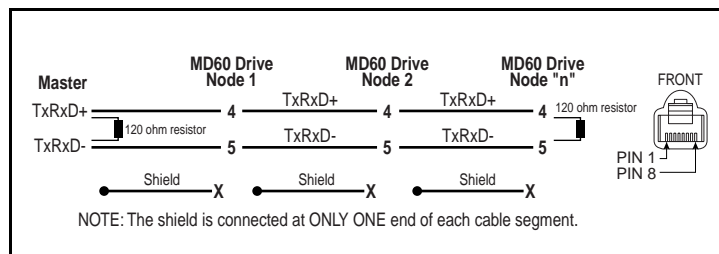

Figure F.2 – Network Wiring Diagram

Only pins 4 and 5 on the RJ45 plug should be wired. The other pins on the MD60 RJ45 socket contain power, etc., for other Rockwell Automation peripheral devices and must not be connected.

Wiring terminations on the master controller will vary depending on the master controller used and “TxRxD+” and “TxRxD-” are shown for illustration purposes only. Refer to the master controller’s user manual for network terminations. Note that there is no standard for the “+” and “-” wires, and consequently Modbus device manufacturers interpret them differently. If you have problems with initially establishing communications, try swapping the two network wires at the master controller.

Standard RS485 wiring practices apply. Termination resistors need to be applied at each end of the network cable. RS485 repeaters may need to be used for long cable runs, or if greater than 32 nodes are needed on the network.

Control Terminal 16 on the MD60 must also be connected to PE ground (there are two PE terminals on the drive).

### Parameter Configuration

The following MD60 parameters are used to configure the drive to operate on a network.

Table F.1 – MD60 Network Parameters

Parameter	Details
P036 (Start Source)	Set to 5 “RS485 (MDI) Port” if Start is controlled from the network.
P038 (Speed Reference)	Set to 5 “RS485 (MDI) Port” if the Speed Reference is controlled from the network.
A103 (Comm Data Rate)	Sets the data rate for the RS485 (MDI) Port. All nodes on the network must be set to the same data rate.
A104 (Comm Node Addr)	Sets the node address for the drive on the network. Each device on the network requires a unique node address.
A105 (Comm Loss Action)	Selects the drive’s response to communication problems.
A106 (Comm Loss Time)	Sets the time that the drive will remain in communication loss before the drive implements A105 (Comm Loss Action).
A107 (Comm Format)	Sets the transmission mode, data bits, parity and stop bits for the RS485 (MDI) Port. All nodes on the network must be set to the same setting.

## Supported Modbus Function Codes

The peripheral interface (MDI) used on MD60 drives supports some of the Modbus function codes.

Table F.2 – Supported Modbus Function Codes

Modbus Function Code	Command
03	Read Holding Registers
06	Preset (Write) Single Register

**Important:** Modbus devices can be 0-based (registers are numbered starting at 0) or 1-based (registers are numbered starting at 1). Depending on the Modbus Master used, the register addresses listed on the following pages may need to be offset by +1. For example, Logic Command may be register address 8192 for some master devices (e.g., ProSoft 3150-MCM SLC Modbus scanner) and 8193 for others (e.g., PanelViews).

## Writing (06) Logic Command Data

The MD60 drive can be controlled via the network by sending Function Code 06 writes to register address 8192 (Logic Command). P036 (Start Source) must be set to 5 "RS485 (MDI) Port" in order to accept the commands.

Table F.3 – Logic Commands

Logic Command			
Address (Decimal)	Bit(s)	Description	
8192	0	1 = Stop, 0 = Not Stop	
	1	1 = Start, 0 = Not Start	
	2	1 = Jog, 0 = No Jog	
	3	1 = Clear Faults, 0 = Not Clear Faults	
	5,4	00	No Command
		01	Forward Command
		10	Reverse Command
		11	Change Direction (Toggle)
	6	Not Used	
	7	Not Used	
	9,8	00	No Command
		01	Accel Rate 1 Enable
		10	Accel Rate 2 Enable
		11	Hold Accel Rate Selected
	11,10	00	No Command
		01	Decel Rate 1 Enable
		10	Decel Rate 2 Enable
		11	Hold Decel Rate Selected
	14,13,12	000	No Command
		001	Freq. Source = P036 (Start Source)
010		Freq. Source = A069 (Internal Freq)	
011		Freq. Source = Comms (Addr 8193)	
100		A070 (Preset Freq 0)	
101		A071 (Preset Freq 1)	
110		A072 (Preset Freq 2)	
111		A073 (Preset Freq 3)	
15	Not Used		

## Writing (06) Reference

The Speed Reference to a MD60 drive can be controlled via the network by sending Function Code 06 writes to register address 8193 (Reference). P038 (Speed Reference) must be set to 5 “RS485 (MDI) Port” in order to accept the Speed Reference.

Table F.4 – Reference

Reference	
Address (Decimal)	Description
8193	A decimal value entered as xxx.x where the decimal point is fixed. For example, a decimal “100” equals 10.0 Hz and “543” equals 54.3 Hz.

## Reading (03) Logic Status Data

The MD60 Logic Status data can be read via the network by sending Function Code 03 reads to register address 8448 (Logic Status).

Table F.5 – Logic Status Data

Logic Status		
Address (Decimal)	Bit(s)	Description
8448	0	1 = Ready, 0 = Not Ready
	1	1 = Active (Running), 0 = Not Active
	2	1 = Cmd Forward, 0 = Cmd Reverse
	3	1 = Rotating Forward, 0 = Rotating Reverse
	4	1 = Accelerating, 0 = Not Accelerating
	5	1 = Decelerating, 0 = Not Decelerating
	6	1 = Alarm, 0 = No Alarm
	7	1 = Faulted, 0 = Not Faulted
	8	1 = At Reference, 0 = Not At Reference
	9	1 = Reference Controlled by Comm
	10	1 = Operation Cmd Controlled by Comm
	11	1 = Parameters have been locked
	12	Digital Input 1 Status
	13	Digital Input 2 Status
	14	Not Used
15	Not Used	

## Reading (03) Feedback

The Feedback (Output Frequency) from the MD60 drive can be read via the network by sending Function Code 03 reads to register address 8451 (Feedback).

Table F.6 – Feedback

Feedback <sup>1</sup>	
Address (Decimal)	Description
8451	A xxx.x decimal value where the decimal point is fixed. For example, a decimal "123" equals 12.3 Hz and "300" equals 30.0 Hz.

<sup>1</sup> Returns the same data as Reading (03) Parameter d001 (Output Freq).

### Reading (03) Drive Error Codes

The MD60 Error Code data can be read via the network by sending Function Code 03 reads to register address 8449 (Drive Error Codes).

Table F.7 – Error Codes

Logic Status		
Address (Decimal)	Value (Decimal)	Description
8449	0	No Fault
	2	Auxiliary Input
	3	Power Loss
	4	Undervoltage
	5	Overvoltage
	6	Motor Stalled
	7	Motor Overload
	8	Heatsink Overtemperature
	12	HW Overcurrent (300%)
	13	Ground Fault
	29	Analog Input Loss
	33	Auto Restart Tries
	38	Phase U to Ground Short
	39	Phase V to Ground Short
	40	Phase W to Ground Short
	41	Phase UV Short
	42	Phase UW Short
	43	Phase VW Short
	63	Software Overcurrent
	64	Drive Overload
70	Power Unit Fail	
80	AutoTune Fail	
81	Communication Loss	
100	Parameter Checksum Error	
122	I/O Board Fail	

### **Reading (03) and Writing (06) Drive Parameters**

To access drive parameters, the Modbus register address equals the parameter number. For example, a decimal "1" is used to address parameter d001 (Output Freq) and decimal "39" is used to address parameter P039 (Accel Time 1).

# APPENDIX G

## RJ45 Splitter Cable

The MD60 drive provides a RJ45 port to allow the connection of a single peripheral device. The RJ45 Splitter Cable can be used to connect a second MDI peripheral device to the drive.

### Connectivity Guidelines



**ATTENTION:** The peripherals may not perform as intended if these Connectivity Guidelines are not followed. Precautions should be taken to follow these Connectivity Guidelines. Failure to observe these precaution may result in damage to, or destruction of, the equipment.

- Two peripherals maximum can be attached to a drive.
- If a single peripheral is used, it must be connected to the Master port (M) on the splitter and configured for “Auto” (default) or “Master.” Parameter 9 (Device Type) on the OIM keypads and parameter 1 (Module Cfg) on the Serial Converter are used to select the type (Auto / Master / Slave).
- **Do not use the RJ45 Splitter Cable with a drive that has an internal network communication module installed.** Since only one additional peripheral can be added, the second peripheral can be connected directly to the RJ45 port on the drive. The internal Comm is always the Master, therefore the external peripheral must be configured as “Auto” (for temporary connections) or “Slave” (for permanent connections).
- If two peripherals will be powered up at the same time, one must be configured as the “Master” and connected to the Master port (M) and the other must be connected as the “Slave” and connected to the Slave port (S).

## Cable Accessories

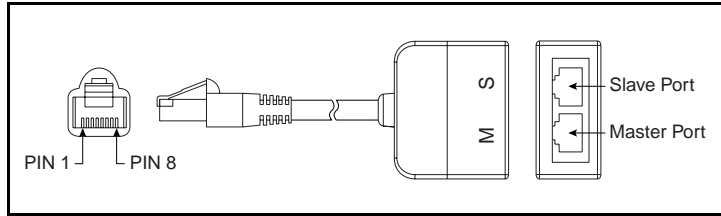

Figure G.1 – RJ45 Splitter Cable (M/N AK-U0-RJ45-SCI)

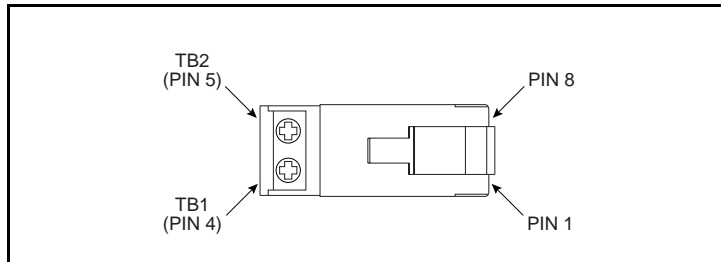

Figure G.2 – RJ45 Two-Position Terminal Block Module  
M/N AK-U0-RJ45-TB2P

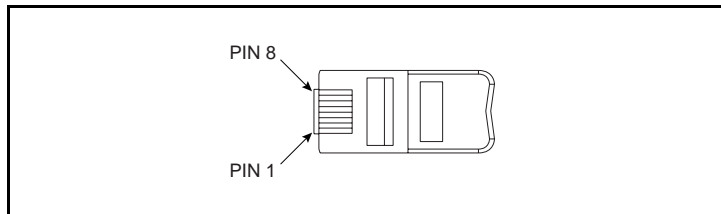

Figure G.3 – RJ45 Module With Integrated Termination Resistor  
(M/N AK-U0-RJ45-TR1)

### Connecting One Temporary Peripheral

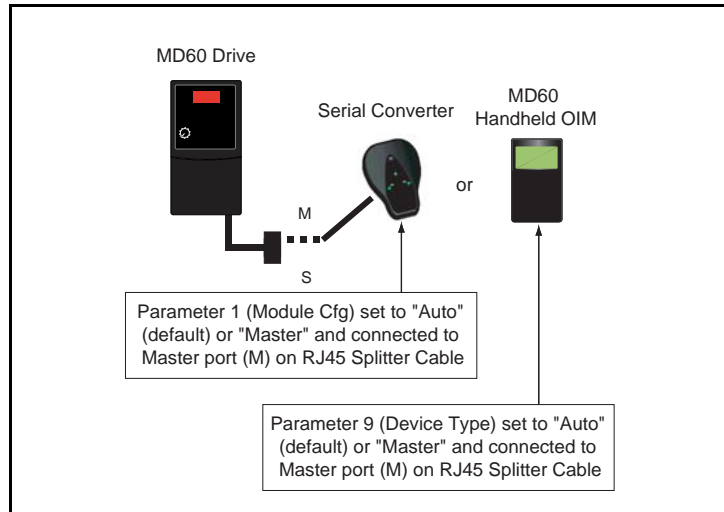

Figure G.4 – Connecting One Temporary Peripheral

### Connecting One Temporary Peripheral and One Permanent Peripheral

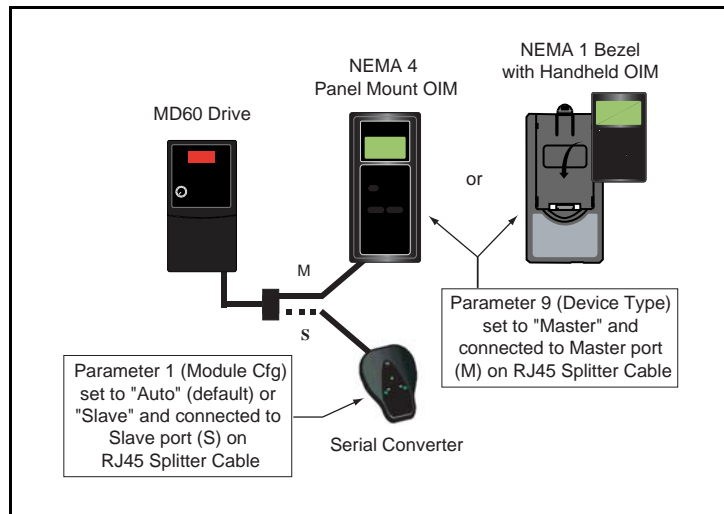

Figure G.5 – Connecting One Temporary Peripheral and One Permanent Peripheral

## Connecting Two Permanent Peripherals

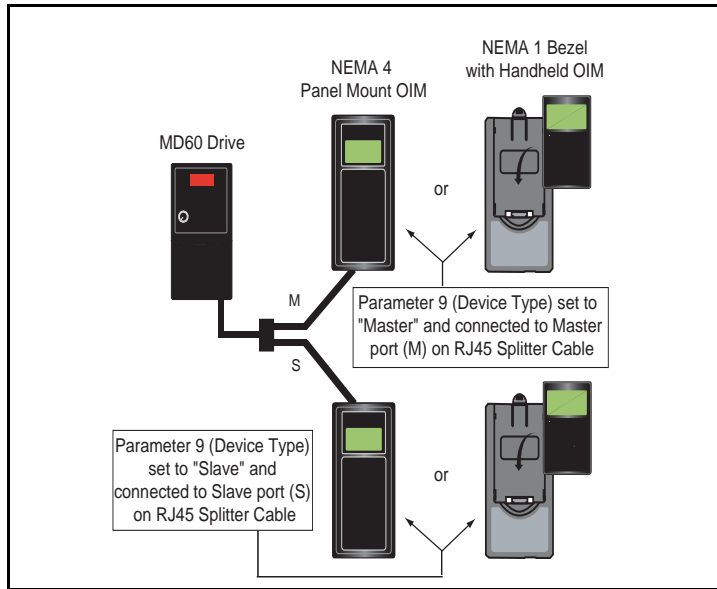

Figure G.6 – Connecting Two Permanent Peripherals

## Connecting an RS485 Network

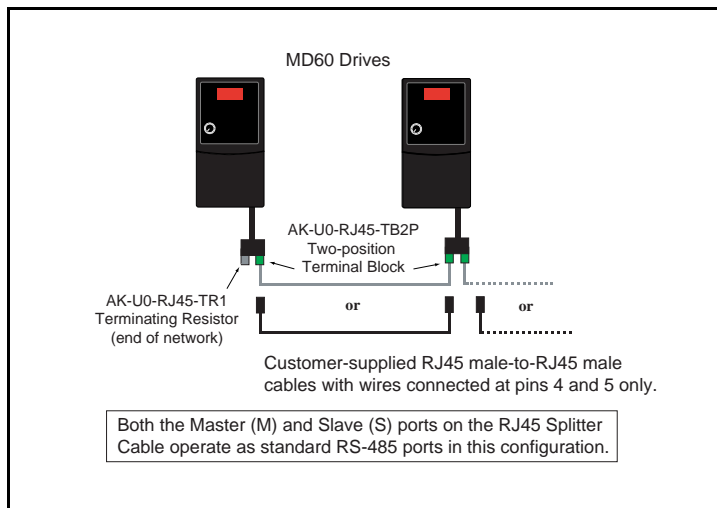

Figure G.7 – Connecting an RS485 Network

# INDEX

---

## Numerics

0 - 10 V Analog Input (d020), 9-32  
0 - 10 V Analog Input High (A111), 9-24  
0 - 10 V Analog Input Low (A110), 9-24  
4 - 20 mA Analog Input High  
(A113), 9-25  
4 - 20 mA Analog Input Low (A112), 9-25  
4 to 20 mA Analog Input (d021), 9-32

## A

A parameters, 9-8 to 9-26  
Accel Time 1 (P039), 9-7  
Accel Time 2 (A067), 9-11  
accel/decel selection, 6-9  
accessories, E-1 to E-8  
Advanced parameters, 9-8 to 9-26  
Auto Restart Delay (A093), 9-19  
Auto Restart feature, 10-2  
Auto Restart Tries (A092), 9-18  
Auto Restart Tries fault, 10-4  
Auxiliary Input fault, 10-3

## B

Basic parameters, 9-2 to 9-7  
Bezel Kit, E-6, E-8

## C

CE conformance requirements, D-1 to  
D-3  
circuit breakers, 5-6 to 5-7, A-2  
Comm Data Rate (A103), 9-22  
Comm Format (A107), 9-23  
Comm Loss Action (A105), 9-22  
Comm Loss fault, 10-5  
Comm Loss Time (A106), 9-23  
Comm Node Address (A104), 9-22  
Comm Status (d015), 9-31  
Commanded Frequency (d002), 9-27  
Compensation (A097), 9-20  
control and signal wiring

recommendations, 6-3  
Control Input Status (d013), 9-30  
Control Source (d012), 9-29  
Control SW Version (d016), 9-31  
control terminal block  
wiring, 6-4  
control wiring, installing, 6-1 to 6-9  
control, 2- and 3-wire, 6-7  
Current Limit (A089), 9-17

## D

d parameters, 9-27 to 9-32  
DB Resistor Kit, 2-3  
DB Resistor Select (A082), 9-15  
DC Brake Level (A081), 9-14  
DC Brake Time (A080), 9-14  
DC Bus Voltage (d005), 9-28  
Decel Time 1 (P040), 9-7  
Decel Time 2 (A068), 9-12  
Digital In1 Select (A051), 9-8  
Digital In2 Select (A052), 9-8  
Digital Input Status (d014), 9-30  
dimensions, drive, 3-3  
Display parameters, 9-27 to 9-32  
Display Scaling (Process Factor  
(A099)), 9-21  
drive  
frame size, 2-2  
model numbers, 2-2  
operating conditions, 3-2  
powering up after installing, 7-2  
ratings, 2-2  
storage guidelines, 2-4  
troubleshooting, 10-1 to 10-9  
Drive Overload fault, 10-5  
Drive Status (d006), 9-28  
Drive Temperature (d024), 9-32  
Drive Type (d017), 9-31  
Dynamic Brake Modules, E-1

## E

Elapsed Run Time (d018), 9-31  
EMC Line Filters, E-3  
EMC/RFI  
    grounding, filter, 4-2  
EMI filters, 2-3

## F

fault  
    buffers, *see*, Fault n Code  
        (d007-d009)  
    clearing automatically, 10-2  
    clearing manually, 10-2  
    codes, 10-1  
    descriptions and corrective  
        actions, 10-3  
    log, *see*, Fault n Code (d007-d009)  
Fault 1 Code (d007), 9-28  
Fault 2 Code (d008), 9-28  
Fault 3 Code (d009), 9-28  
Fault Clear (A100), 9-21  
faults  
    Auto Restart Tries, 10-4  
    Auxiliary Input, 10-3  
    Comm Loss, 10-5  
    Drive Overload, 10-5  
    Ground Fault, 10-4  
    Heatsink OverTemp, 10-4  
    HW OverCurrent, 10-4  
    I/O Board Fail, 10-5  
    Motor Overload, 10-3  
    Motor Stalled, 10-3  
    OverVoltage, 10-3  
    Parameter Checksum, 10-5  
    Phase Short, 10-4  
    Phase to Ground Short, 10-4  
    Power Loss, 10-3  
    Power Unit, 10-5  
    SW OverCurrent, 10-5  
    UnderVoltage, 10-3  
filter, RFI, 4-2  
Flying Start Enable (A096), 9-20  
frames and ratings, 2-2  
fuses, 5-6 to 5-7, A-2

## G

Ground Fault, 10-4  
ground fault monitoring, 4-2  
grounding the drive, 4-1 to 4-2

## H

Heatsink OverTemp fault, 10-4  
HW OverCurrent fault, 10-4

## I

I/O Board Fail fault, 10-5  
I/O wiring, 6-4  
I/O wiring examples, 6-5, 6-7  
input potentiometer, 6-5  
input power conditioning, 5-4  
installation, 7-1  
Internal Frequency (A069), 9-12

## J

Jog Accel/Decel (A079), 9-13  
Jog Frequency (A078), 9-13

## K

key descriptions, 8-3  
keypad components, 8-1  
kits, 2-3

## L

LED descriptions, 8-2

## M

machinery safety standard, compliance  
    with, 6-2  
Maximum Frequency (P035), 9-2  
Maximum Voltage (A088), 9-17  
Minimum Frequency (P034), 9-2  
model numbers, 2-1  
motor cable length, 5-9  
motor cable types, 200-600 V  
    installations, 5-8  
Motor NP Hertz (P032), 9-2  
Motor NP Volts (P031), 9-2  
Motor OL Current (P033), 9-2  
Motor OL Select (A090), 9-17  
Motor Overload fault, 10-3  
Motor Stalled fault, 10-3  
motor start/stop precautions, 6-2  
mounting clearances, 3-2  
mounting specifications, 3-4  
mounting the drive, 3-1 to 3-4  
MOVs, 5-3

## N

NEMA 1/IP30 Kit, 2-3

## O

OIMs, E-6  
operating conditions, 3-2  
Operator Interface Modules (OIMs), E-6  
Output Current (d003), 9-27  
output disconnect, 5-10  
Output Frequency (d001), 9-27  
Output Voltage (d004), 9-27  
OverVoltage fault, 10-3

## P

P parameters, 9-2 to 9-7  
Parameter Checksum fault, 10-5  
parameters  
    A, 9-8 to 9-26  
        about, 8-4  
        Advanced, 9-8 to 9-26  
        Basic, 9-2 to 9-7  
        cross-referenced by name, C-1 to C-3  
        d, 9-27 to 9-32  
        descriptions, 9-1 to 9-32  
        Display, 9-27 to 9-32  
        P, 9-2 to 9-7  
        record of user settings, B-1 to B-3  
        viewing and adjusting Basic (P) and Advanced (A), 8-5  
        viewing Display (d), 8-6  
PE ground, 4-2  
Phase Short fault, 10-4  
Phase to Ground fault, 10-4  
potentiometer, wiring, 6-5  
Power Loss fault, 10-3  
power terminal block  
    connections, 5-5  
    specifications, 5-5  
Power Unit fault, 10-5  
power wiring specifications, 5-5  
power wiring, installing, 5-1 to 5-10  
power-off checks, 7-1  
Preset Frequency 0 (A070), 9-13  
Preset Frequency 1 (A071), 9-13  
Preset Frequency 2 (A072), 9-13  
Preset Frequency 3 (A073), 9-13  
Process Display (d010), 9-29  
Process Factor (A099), 9-21

Process Time Hi (A116), 9-26  
Process Time Lo (A115), 9-26  
Program Lock (A101), 9-21  
protective features, A-2  
PWM Frequency (A091), 9-18

## R

reflective wave protection, 5-9  
Relay Output Level (A056), 9-11  
Relay Output Select (A055), 9-9  
Reset to Defaults (P041), 9-7  
Reverse Disable (A095), 9-19  
RJ45 Splitter Cable, G-1 to G-4  
RS485 (MDI) protocol, F-1 to F-8  
RWR (Reflective Wave Reducer), 5-9

## S

S Curve % (A083), 9-15  
safety ground, 4-2  
Serial Converter, MD60, 2-3  
shield termination, 4-2  
shielded motor cable, 5-8  
Slip Compensation (A114), 9-25  
specifications, technical, A-1  
Speed Reference (P038), 9-6  
speed reference control, 6-8  
Start At Power Up (A094), 9-19  
Start Boost (A084), 9-16  
Start Source (P036), 9-3  
starting up the drive, 7-1  
stop circuit requirements, 6-1  
Stop Mode (P037), 9-5  
storage guidelines, 2-4  
SW Current Trip (A098), 9-21  
SW OverCurrent fault, 10-5

## T

technical assistance, 1-1  
terminal block  
    control, 6-4  
    power, 5-5  
Testpoint Data (d019), 9-32  
Testpoint Select (A102), 9-22  
three-wire control, 6-7  
troubleshooting tables, 10-6 to 10-9  
troubleshooting the drive, 10-1 to 10-9  
two-wire control, 6-7

## U

UnderVoltage fault, 10-3  
ungrounded distribution systems, 5-2  
unshielded power cables, 5-8

## W

weight, drive, 3-3  
wiring  
    I/O examples, 6-7  
wiring specifications  
    control and signal, 6-3  
    power, 5-5

# DIF

## Documentation Improvement Form

Use this form to give us your comments concerning this publication or to report an error that you have found. For convenience, you may attach copies of the pages with your comments. After you have completed this form, please return it to:

Reliance Electric  
Standard Drives - Technical Documentation  
6040 Ponders Court  
Greenville, SC 29617

Fax: 864-284-5483

Publication Name: <b>MD60 AC Drive User Manual</b>	
Publication Number: <b>D2-3499-3</b>	Publication Date: September 2003

Comments:

---

---

---

---

---

Your Name:	Date:
Company Name:	Phone: (    )
Address:	
E-mail:	

Thank you for your comments.

<b>Technical Writing Internal Use</b>	
Date:	DIF Number:
Follow-Up Action:	

**Rockwell**  
Automation





[www.rockwellautomation.com](http://www.rockwellautomation.com)

**Corporate Headquarters**

Rockwell Automation, 777 East Wisconsin Avenue, Suite 1400, Milwaukee, WI, 53202-5302 USA, Tel: (1) 414.212.5200, Fax: (1) 414.212.5201

**Headquarters for Allen-Bradley Products, Rockwell Software Products and Global Manufacturing Solutions**

Americas: Rockwell Automation, 1201 South Second Street, Milwaukee, WI 53204-2496 USA, Tel: (1) 414.382.2000, Fax: (1) 414.382.4444  
Europe: Rockwell Automation SA/NV, Vorstlaan/Boulevard du Souverain 36-BP 3A/B, 1170 Brussels, Belgium, Tel: (32) 2 663 0600, Fax: (32) 2 663 0640  
Asia Pacific: Rockwell Automation, 27/F Citicorp Centre, 18 Whitfield Road, Causeway Bay, Hong Kong, Tel: (852) 2887 4788, Fax: (852) 2508 1846

**Headquarters for Dodge and Reliance Electric Products**

Americas: Rockwell Automation, 6040 Ponders Court, Greenville, SC 29615-4617 USA, Tel: (1) 864.297.4800, Fax: (1) 864.281.2433  
Europe: Rockwell Automation, Brühlstraße 22, D-74834 Elztal-Dallau, Germany, Tel: (49) 6261 9410, Fax: (49) 6261 1774  
Asia Pacific: Rockwell Automation, 55 Newton Road, #11-01/02 Revenue House, Singapore 307987, Tel: (65) 351 6723, Fax: (65) 355 1733

Reliance Electric Standard Drives Business, P.O. Box 248019, Mayfield Heights, OH 44124-8019 USA, Tel: (1) 888.374.8370, Fax: 440.646.7317

Publication D2-3499-3 - September 2003

© 2003 Rockwell International Corporation. All rights reserved.