

**GV3000/SE AC Drive
Hardware Reference, Installation,
and Troubleshooting
75-200 HP @ 460 VAC
Version 6.04**



Instruction Manual D2-3392-3

**Rockwell
Automation**

The information in this manual is subject to change without notice.

Throughout this manual, the following notes are used to alert you to safety consideration:



ATTENTION: Identifies information about practices or circumstances that can lead to personal injury or death, property damage, or economic loss.

Important: Identifies information that is critical for successful application and understanding of the product.



ATTENTION: Only qualified electrical personnel familiar with the construction and operation of this equipment and the hazards involved should install, adjust, operate, or service this equipment. Read and understand this manual and other applicable manuals in their entirety before proceeding. Failure to observe this precaution could result in severe bodily injury or loss of life.

ATTENTION: DC bus capacitors retain hazardous voltages after input power has been disconnected. After disconnecting input power, wait five (5) minutes for the DC bus capacitors to discharge and then check the voltage with a voltmeter to ensure the DC bus capacitors are discharged before touching any internal components. Failure to observe this precaution could result in severe bodily injury or loss of life.

ATTENTION: The drive can operate at and maintain zero speed. The user is responsible for assuring safe conditions for operating personnel by providing suitable guards, audible or visual alarms, or other devices to indicate that the drive is operating or may operate at or near zero speed. Failure to observe this precaution could result in severe bodily injury or loss of life.

ATTENTION: Do not install modification kits with power applied to the drive. Disconnect and lock out incoming power before attempting such installation or removal. Failure to observe this precaution could result in severe bodily injury or loss of life.

ATTENTION: The user must provide an external, hardwired emergency stop circuit outside of the drive circuitry. This circuit must disable the system in case of improper operation. Uncontrolled machine operation may result if this procedure is not followed. Failure to observe this precaution could result in bodily injury.

ATTENTION: The user is responsible for conforming with all applicable local, national, and international codes. Failure to observe this precaution could result in damage to, or destruction of, the equipment.

DeviceNet is a trademark of the Open DeviceNet Vendor Association.

ControlNet is a trademark of ControlNet International Ltd.

PROFIBUS is a trademark of PROFIBUS International.

GV3000/SE, AutoMax, ControlNet, and Reliance are trademarks of Rockwell International.

© 1999 Rockwell International Corporation.

CONTENTS

Chapter 1	Becoming Familiar with the Manual	
1.1	Finding Information	1-1
1.2	Assumptions About the Audience	1-2
1.3	Understanding Terms Used in this Manual	1-2
1.4	If You Want to Know More	1-2
1.5	Getting Assistance from Reliance Electric	1-2
Chapter 2	About the Drive	
2.1	Identify the Drive by Model Number	2-1
2.2	Enclosures	2-2
2.3	75-200 HP GV3000/SE Drive Component Locations	2-3
2.4	Regulator Board Description	2-6
2.4.1	Jumper Locations and Settings	2-8
2.4.1.1	Analog Input Speed Reference Jumper (J4)	2-8
2.4.1.2	Analog Output Jumper (J17)	2-9
2.4.2	Wiring the Terminal Strip	2-10
2.4.3	RS-232 Communication Port	2-11
2.4.4	Option Board Connector	2-11
2.4.5	Operator Interface Module Connector	2-11
2.4.6	Keypad/Display	2-12
2.5	Jumpers on Base Board (PISC-75/75A)	2-12
2.6	Drive Kit Options	2-13
Chapter 3	Planning Before Installing	
3.1	Requirements for the Installation Site	3-1
3.1.1	Making Sure Environmental Conditions are Met	3-1
3.1.2	Determining Total Area Required Based on Drive Dimensions	3-2
3.1.3	Verifying the Site Provides for Recommended Air Flow Clearances	3-4
3.1.4	Verifying Power Module AC Input Ratings Match Supplied Power	3-5
3.2	Wiring Requirements for the Drive	3-5
3.2.1	Meeting Terminal Strip Input and Output Specifications	3-5
3.2.2	Determining Wire Size Requirements	3-5
3.2.2.1	Recommended Power Wire Sizes	3-5
3.2.2.2	Recommended Control and Signal Wire Sizes	3-6
3.2.2.3	Recommended Motor Lead Lengths	3-6
3.2.2.4	Recommended Serial Communication Cable Lengths	3-8
3.2.3	Selecting AC Input Line Branch Circuit Fuses, Circuit Breakers, and AC Reactors	3-8
3.2.4	Meeting Encoder Specifications (FVC Regulation Only)	3-9
3.2.4.1	Encoder Wiring Guidelines	3-9
3.2.5	Verifying Power Module Output Current Rating is Greater Than Motor Full Load Amps	3-9

Chapter 4	Mounting the Drive, Grounding, and Finding Wire Routing Locations	
4.1	Mounting the Drive	4-1
4.1.1	Verifying the Drive's Watts Loss Rating	4-1
4.2	Routing Input, Motor Output, Ground, and Control Wiring for the Drive	4-1
4.3	Grounding the Drive	4-2
Chapter 5	Installing Input Power Wiring	
5.1	Installing Transformers and Reactors (Optional)	5-1
5.2	Installing Fuses for Branch Circuit Protection	5-2
5.3	Installing a Required External/Separate Input Disconnect	5-2
5.4	Installing Power Wiring from the AC Input Line to the Drive's Power Terminals	5-5
5.5	Installing Power Wiring from an External DC Bus to the Drive's Internal DC Bus Terminals	5-5
Chapter 6	Installing Output Power Wiring	
6.1	Installing Output Contactors (Optional)	6-1
6.2	Installing Mechanical Motor Overload Protection (Optional)	6-1
6.3	Installing Output Wiring from the Drive Output Terminal to the Motor	6-1
Chapter 7	Wiring the Regulator Board Terminal Strip	
7.1	Stopping the Drive	7-6
7.2	Wiring the Encoder Feedback Device (FVC Regulation Only)	7-6
7.3	Wiring the Signal and Control I/O	7-9
Chapter 8	Completing the Installation	
8.1	Checking the Installation	8-1
8.2	Powering Up After Installation is Complete	8-2
Chapter 9	Troubleshooting the Drive	
9.1	Test Equipment Needed to Troubleshoot	9-1
9.2	Drive Alarms and Faults	9-1
9.3	Verifying That DC Bus Capacitors are Discharged	9-1
9.4	Checking Out the Power Module with Input Power Off	9-2
9.5	Replacement Parts	9-4
Appendix A	Technical Specifications	A-1
Appendix B	75-200 HP GV3000/SE System Wiring Diagram	B-1

List of Figures

- Figure 2.1 – Identifying the Drive Model Number 2-1
- Figure 2.2 – 75 and 100 HP Drive Component Locations 2-3
- Figure 2.3 – 125 HP Drive Component Locations 2-4
- Figure 2.4 – 150 and 200 HP Drive Component Locations 2-5
- Figure 2.5 – Regulator Board Component Locations 2-7
- Figure 2.6 – Jumper J4 Settings for Analog Input Speed Reference 2-9
- Figure 2.7 – Jumper J17 Settings for Analog Outputs 2-10
- Figure 2.8 – Typical Terminal Strip Connections 2-11
- Figure 2.9 – Keypad/Display 2-12
- Figure 2.10 – Base Board Jumper Locations 2-13

- Figure 3.1 – Drive Dimensions 3-3
- Figure 3.2 – Recommended Air Flow Clearances 3-4
- Figure 3.3 – How to Measure Motor Lead Lengths 3-7

- Figure 4.1 – Terminal Locations 4-3

- Figure 5.1 – Typical AC Input Electrical Connections 5-3
- Figure 5.2 – Typical DC Bus Electrical Connections 5-4

- Figure 7.1 – Two-Wire Start/Stop Sample Control Wiring 7-4
- Figure 7.2 – Three-Wire Start/Stop Sample Control Wiring 7-5
- Figure 7.3 – Encoder Wiring Connections 7-8

- Figure 9.1 – DC Bus Voltage Terminals 9-2

List of Tables

Table 2.1 – Power Ratings	2-2
Table 2.2 – Settings of Jumpers on Base Board	2-12
Table 2.3 – Available Kits and Options	2-13
Table 3.1 – Ambient Conditions	3-2
Table 3.2 – Drive Dimensions and Weights	3-2
Table 3.3 – Recommended Power Wire Sizes for 75 and 100 HP Drives	3-5
Table 3.4 – Recommended Power Wire Sizes for 125 HP Drive	3-6
Table 3.5 – Recommended Power Wire Sizes for 150 and 200 HP Drives	3-6
Table 3.6 – Recommended Terminal Strip Wire Sizes	3-6
Table 3.7 – Motor Lead Lengths	3-7
Table 3.8 – Reactors	3-7
Table 3.9 – AC Input Line Fuse Selection Values	3-8
Table 3.10 – Circuit Breaker Selection Values	3-9
Table 3.11 – AC Reactor Selection Values	3-9
Table 5.1 – AC Line Reactors	5-2
Table 7.1 – RS-232 Connections (Terminals 1-3)	7-1
Table 7.2 – Encoder Connections (Terminals 4-9)	7-1
Table 7.3 – Analog Output Connections (Terminals 10 and 11)	7-2
Table 7.4 – Analog Speed/Torque Reference Connections (Terminals 12-15)	7-2
Table 7.5 – Digital Input Connections (Terminals 16-25)	7-2
Table 7.6 – Snubber Resistor Braking Connections (Terminals 26 and 27) ...	7-3
Table 7.7 – Status Relay Connections (Terminals 28-31)	7-3
Table 7.8 – Wiring Signal and Control I/O to the Terminal Strip	7-9
Table 9.1 – Resistance Checks	9-3
Table 9.2 – Replacement Parts for the GV3000/SE Drives	9-4
Table A.1 – Service Conditions	A-1
Table A.2 – Environmental Condition	A-2
Table A.3 – Terminal Strip Input Specifications	A-2
Table A.4 – Terminal Strip Output Specifications	A-2
Table A.5 – Terminal Strip RS-232 Specifications	A-3
Table A.6 – Encoder Feedback Device Specifications (FVC Regulation Only)	A-3
Table A.7 – Input Signal Response Times (Maximum)	A-4

Becoming Familiar with the Manual

This chapter provides help in finding information in the manual and describes the intended audience. Also included are references to other related publications and instructions on receiving assistance from Reliance Electric.

1.1 Finding Information

This instruction manual describes the GV3000/SE drive's Power Module and regulator hardware. It does not cover the GV3000/SE software. For software information, refer to the GV3000/SE 460 VAC General Purpose (V/Hz) and Vector Duty Drive Software Start-Up and Reference Manual (D2-3391).

As an aid in finding information in this manual, each chapter is briefly described below:

- Chapter 1 - Becoming Familiar with the Manual
Provides information on how the manual is organized and where to find additional information.
- Chapter 2 - About the Drive
Identifies drive components and shows their locations.
- Chapter 3 - Planning Before Installing
Presents information that must be considered when planning a drive installation.
- Chapter 4 - Mounting the Drive, Grounding, and Finding Wire Routing Locations
Describes how to mount the drive and properly ground it.
- Chapter 5 - Installing Input Power Wiring
Describes incoming AC and DC line components and how to properly connect them.
- Chapter 6 - Installing AC Output Power Wiring
Describes output AC line components and how to properly connect them to the motor.
- Chapter 7 - Wiring the Regulator Board Terminal Strip
Provides information on the I/O wiring that connects the terminal strip on the Regulator board.
- Chapter 8 - Completing the Installation
Provides instructions on how to perform a final check of the installation before power is applied.
- Chapter 9 - Troubleshooting the Drive
Describes the equipment that is needed to troubleshoot the drive and how to measure DC bus voltage. A replacement part list is also provided.

- Appendix A - Technical Specifications
Lists drive specifications in table form.
- Appendix B - 75-200 HP GV3000/SE System Wiring Diagram
Provides additional wiring information for the 75-200 HP drives.

1.2 Assumptions About the Audience

This manual is intended for qualified electrical personnel. It is task-oriented and is organized according to a logical progression of steps to be followed to install and troubleshoot the drive.

1.3 Understanding Terms Used in this Manual

The following terms are defined according to the way they are used in this manual:

- GV3000/SE drives will typically be referenced by horsepower. If additional clarity is required, drive model numbers will also be included.
- Parameters will be referenced either as parameter (P.030) or Elapsed Time Meter Reset (P.030).

1.4 If You Want to Know More

Refer to the following related publications as necessary for more information:

- GV3000/SE 460 VAC General Purpose (Volts/Hertz) and Vector Duty Drive Software Start-up and Reference manual (D2-3391).
- Instruction manuals listed in Table 2.3.

1.5 Getting Assistance from Reliance Electric

If you have any questions or problems with the products described in this instruction manual, contact your local Reliance Electric sales office. For technical assistance, call 1-800-726-8112.

CHAPTER 2

About the Drive

This chapter describes how to identify the drive using the model number matrix. Major components of each drive are also shown.

The GV3000/SE AC drive is a PWM (Pulse-Width-Modulation) drive that provides vector and general purpose regulation for a wide range of applications.

Using vector regulation, the drive can provide high dynamic response, maintain full rated motor torque to zero speed, and precisely control motor speed in both directions. The drive can provide this functionality either with encoder feedback (flux vector control or FVC) or without (sensorless vector control or SVC).

Using general purpose (volts/hertz or V/Hz) regulation, the drive is suited for a broad range of applications requiring adjustable speed control of motors.

2.1 Identify the Drive by Model Number

Each GV3000/SE AC Drive can be identified by its model number. See figure 2.1. This number appears on the shipping label and on the drive's nameplate. The drive's model number includes the Power Module and the regulator. Drive power ratings are provided in table 2.1.

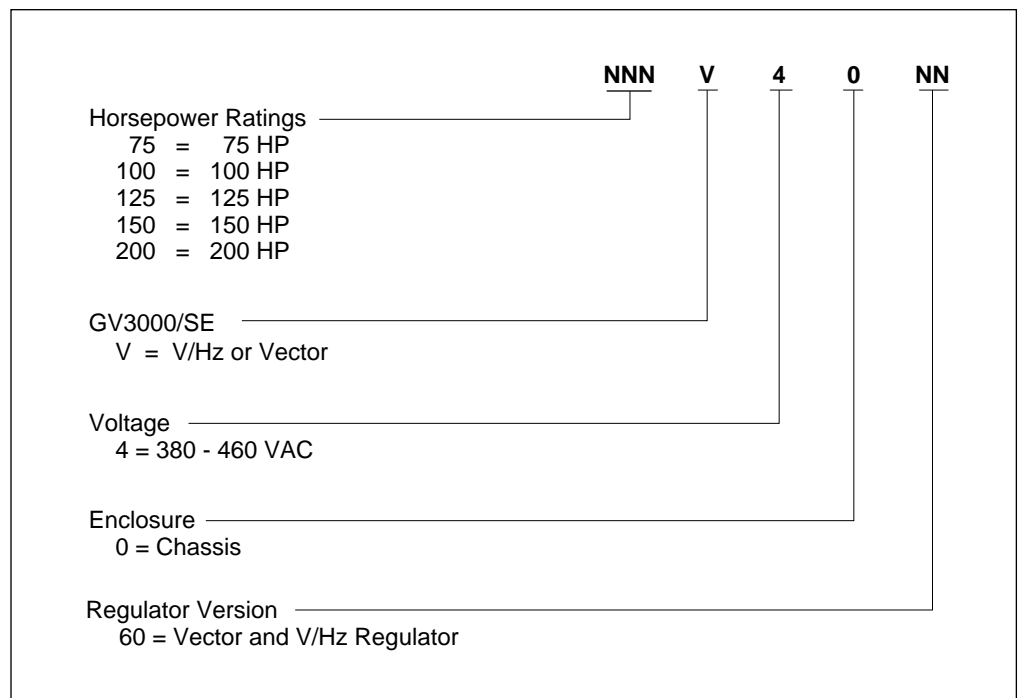

Figure 2.1 – Identifying the Drive Model Number

Table 2.1 – Power Ratings

Model Number	Input Volts (AC)	Input KVA	Input Amps (Maximum)	Output Amps (Maximum) ^{(1) (2)}	Power Loss Watts (Full Load)
75V4060	380-460 VAC +/- 10%	79.7	100 A 380-460 V	100 A 360-460 V	1350
100V4060	380-460 VAC +/- 10%	111.5	140 A 380-460 V	140 A 360-460 V	1650
125V4060	380-460 VAC +/- 10%	135.4	170 A 380-460 V	170 A 360-460 V	2250
150V4060	380-460 VAC +/- 10%	159.3	200 A 380-460 V	200 A 360-460 V	2700
200V4060	380-460 VAC +/- 10%	191.2	240 A 380-460 V	240 A 360-460 V	3300

⁽¹⁾ With vector regulation, 150% output current capability for one minute.

⁽²⁾ These values are for operation with 4 kHz carrier frequency. For operation with 8 kHz carrier frequency, derating by 20% is required.

2.2 Enclosures

This manual describes GV3000/SE chassis style drives. These drives should be installed in cabinets.

2.3 75-200 HP GV3000/SE Drive Component Locations

The 75-200 HP GV3000/SE drives have the following main components. The identification numbers provided correspond to the number used in figures 2.2 to 2.4. Replacement parts are listed in chapter 9.

1. Fan Assembly
2. Membrane Switch (Keypad/Bracket)
3. Regulator Printed Circuit Board
4. Base Board (PISC Board)
5. Bus Capacitor
6. Internal Fan Assembly.

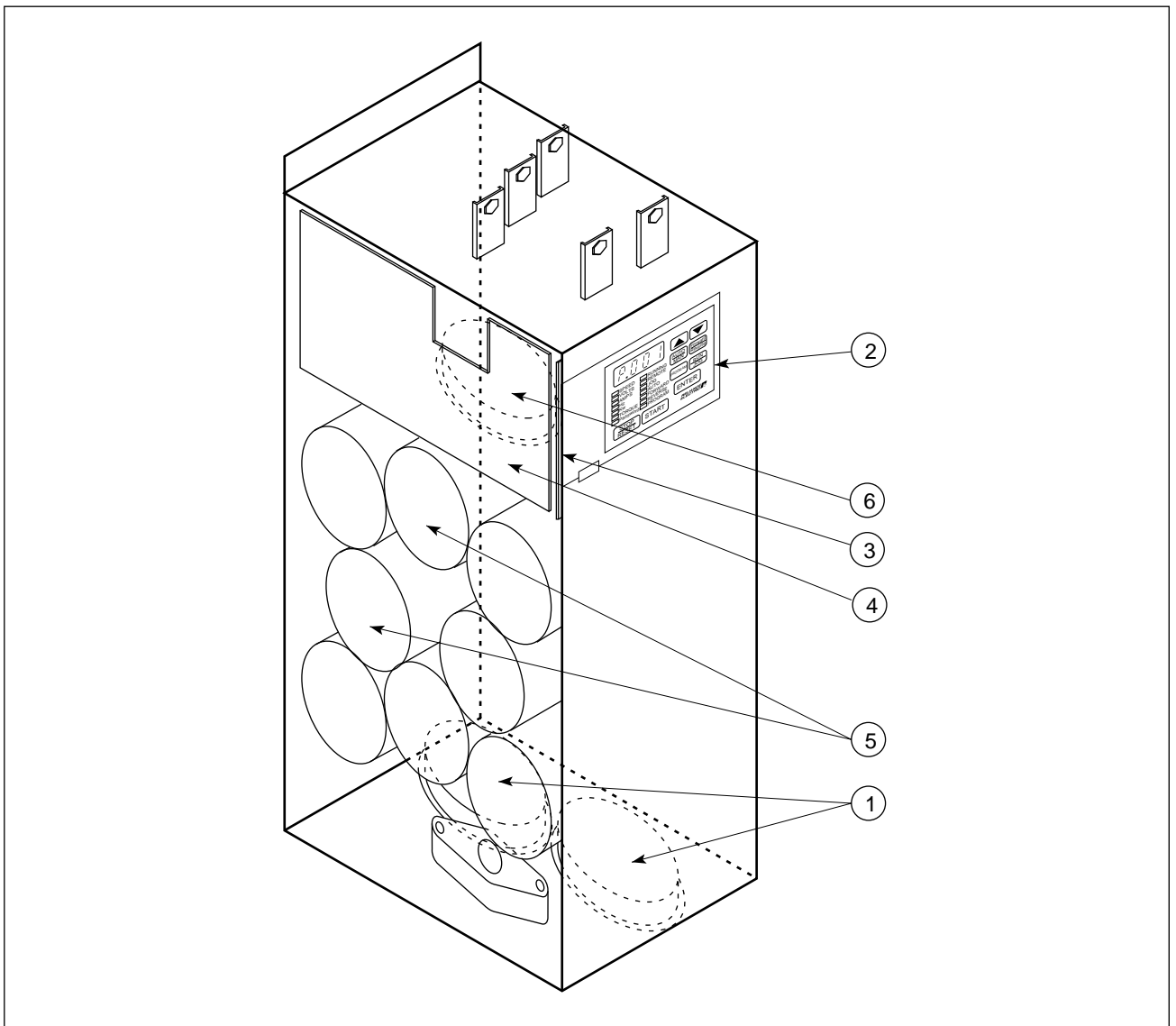

Figure 2.2 – 75 and 100 HP Drive Component Locations

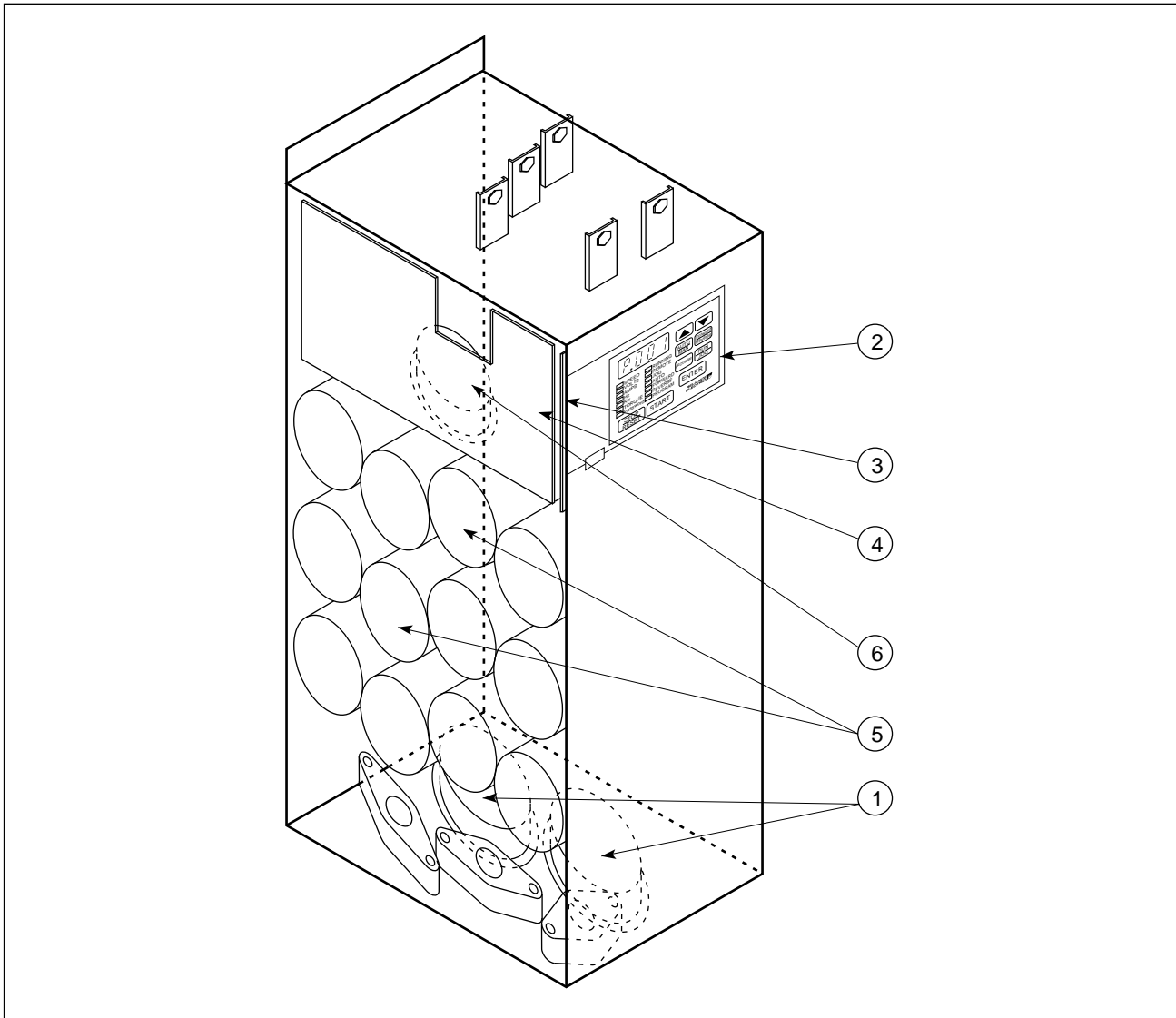

Figure 2.3 – 125 HP Drive Component Locations

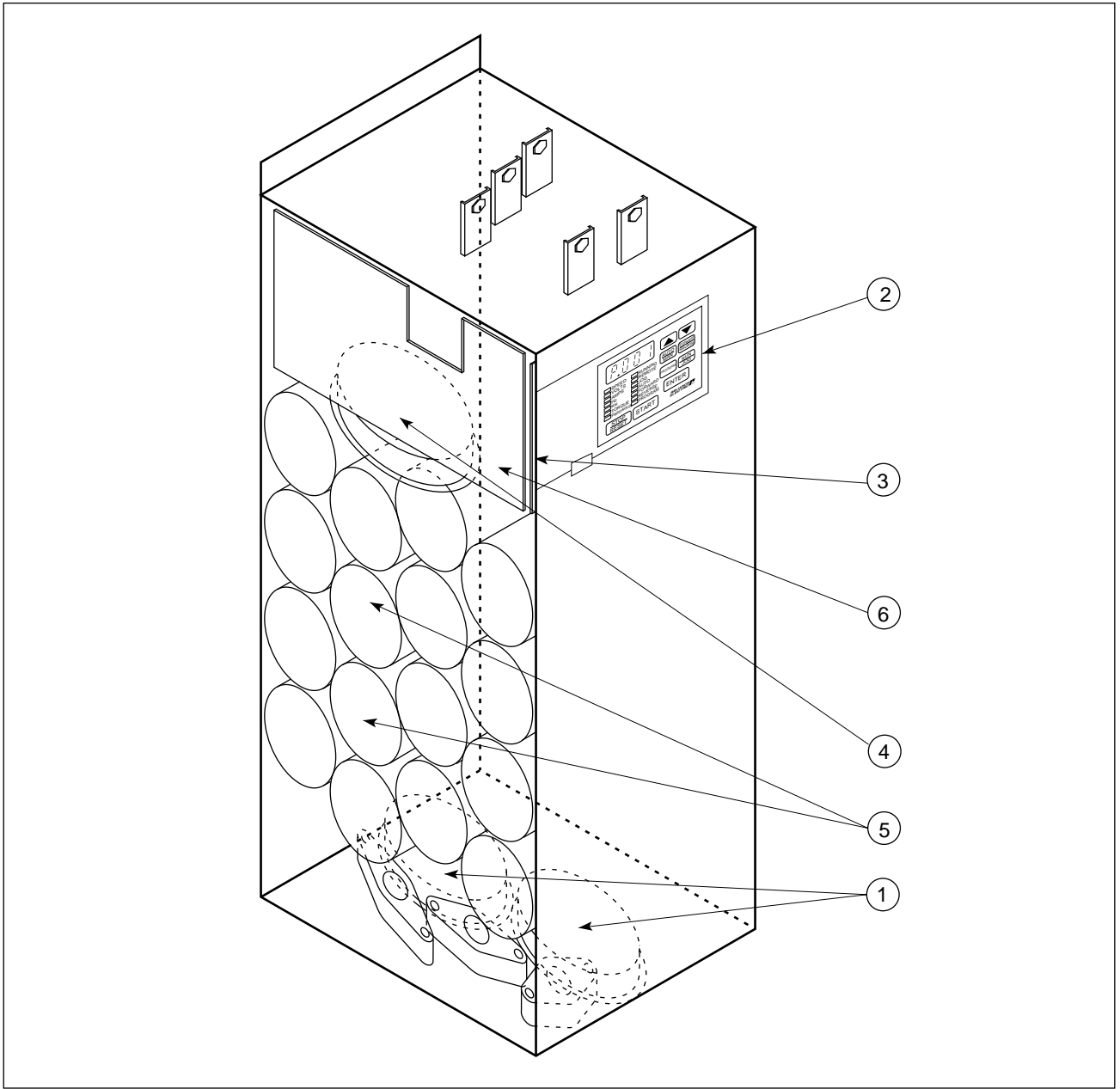

Figure 2.4 – 150 and 200 HP Drive Component Locations

2.4 Regulator Board Description

GV3000/SE drive regulation is performed by a microprocessor on the Regulator board. See figure 2.5. Drive operation is adjusted by the parameters entered through the keypad. The Regulator board accepts power circuit feedback signals and an external speed reference signal, as well as data from encoder that is attached to the motor when set up for FVC regulation. The Regulator board provides:

- PWM gating signals to the IGBT power devices

Based on the output of the control loop, the regulator sends PWM gating signals through the Current Feedback board to isolated drivers on the Gate Driver board. These drivers switch the Insulated Gate Bi-polar Transistors (IGBTs), producing a pulse-width-modulated (PWM) waveform that corresponds to the speed (FVC regulation) or frequency (volts/hertz regulation) reference. The IGBTs can be switched at either a 2, 4 or 8 kHz carrier frequency.

- Form A and B contacts for drive status indicators

The Form A and B contacts are under control of the user via programmable parameters. A Form A or B transition can indicate drive status. The contacts are rated for 5 amps resistive load at 250 VAC/ 30 VDC and are made available through the terminal strip.

- Display data for a four-character display and fourteen indicator LEDs

The four-character display is used to indicate drive parameters, parameter values, and fault codes. The fourteen single LEDs indicate drive status and mode, as well as identifying drive outputs whose values are displayed on the four-character display.

- An analog output

The analog output is a scaled voltage (0-10 VDC) or current (4-20 mA) signal proportional to either motor speed (RPM) or motor torque or current (%TORQUE). The current signal selection (via jumper J17) requires a power supply for operation. The power can be sourced from the encoder terminals (4 and 9) or from an external 15V power supply. See table 7.8, terminals 10 and 11, for more information. The analog output signal is available through the terminal strip.

- A snubber resistor braking signal

The Regulator board provides a signal for use by an optional snubber resistor braking kit. The signal is available through the terminal strip.

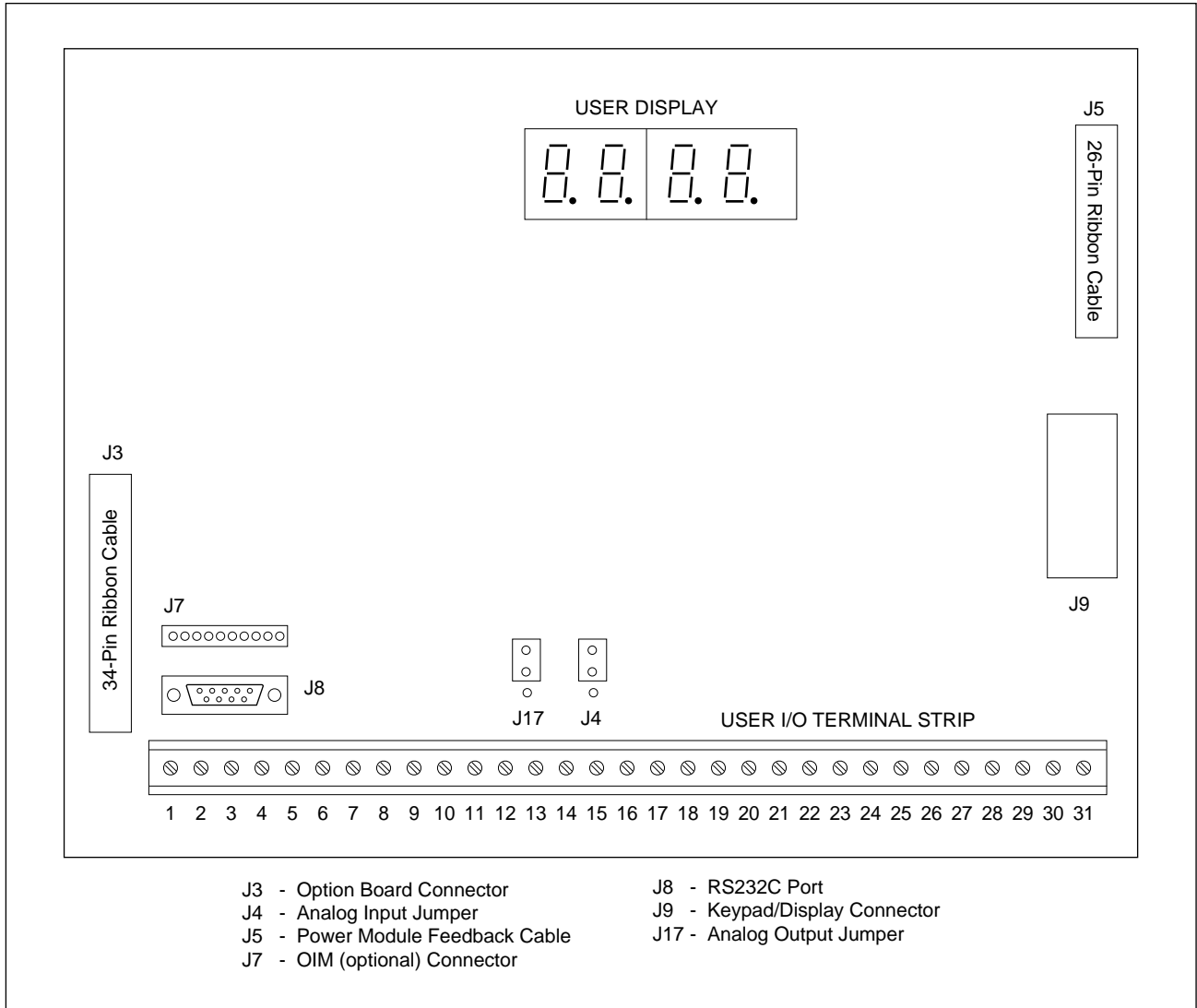

Figure 2.5 – Regulator Board Component Locations

2.4.1 Jumper Locations and Settings

Jumpers J4 and J17 on the Regulator board are factory-set for voltage in and voltage out signals. Refer to figure 2.5 for their locations on the Regulator board. If you need to change the jumpers' settings, use the following procedures.



ATTENTION: Do not alter the setting of any jumper not described in this instruction manual. Failure to observe this precaution could result in damage to, or destruction of, the equipment.

2.4.1.1 Analog Input Speed Reference Jumper (J4)

Jumper J4 is the analog speed/torque (U.000) reference jumper. This jumper selects either +/- 10 VDC or 0-20 mA input. Parameters P.009, P.010, and P.011 are used in conjunction with the jumper. Note that if the position of jumper J4 is changed after the parameters are programmed, the software will not recognize that the input reference or polarity has been changed. Be sure to verify that parameters P.009, P.010, and P.011 are correct before starting the drive. Refer to the GV3000/SE Software Start-Up and Reference manual for more information.

Use the following procedure to set jumper J4:



ATTENTION: DC bus capacitors retain hazardous voltages after input power has been disconnected. After disconnecting input power, wait five (5) minutes for the DC bus capacitors to discharge and then check the voltage with a voltmeter to ensure the DC bus capacitors are discharged before touching any internal components. Failure to observe this precaution could result in severe bodily injury or loss of life.

- Step 1. Turn off input power to the drive and wait five minutes.
- Step 2. Remove the cover from the drive by unscrewing the four attaching screws.
- Step 3. Verify that the DC bus voltage is zero by following the procedure in section 9.3.
- Step 4. Locate jumper J4 on the Regulator board. Refer to figure 2.5.
- Step 5. Locate pin 1 on jumper J4. Move the jumper to the desired setting as shown in figure 2.6.
- Step 6. Reattach the cover.
- Step 7. Reapply input power.
- Step 8. Verify that the Terminal Strip Analog Input Offset (P.009), Terminal Strip Analog Input Gain (P.010), and Terminal Strip Analog Input Configure (P.011) are correctly set. Note that the jumper settings must match the software settings otherwise the reference value may differ from what is expected. Refer to the GV3000/SE Software Start-Up and Reference manual for more information.

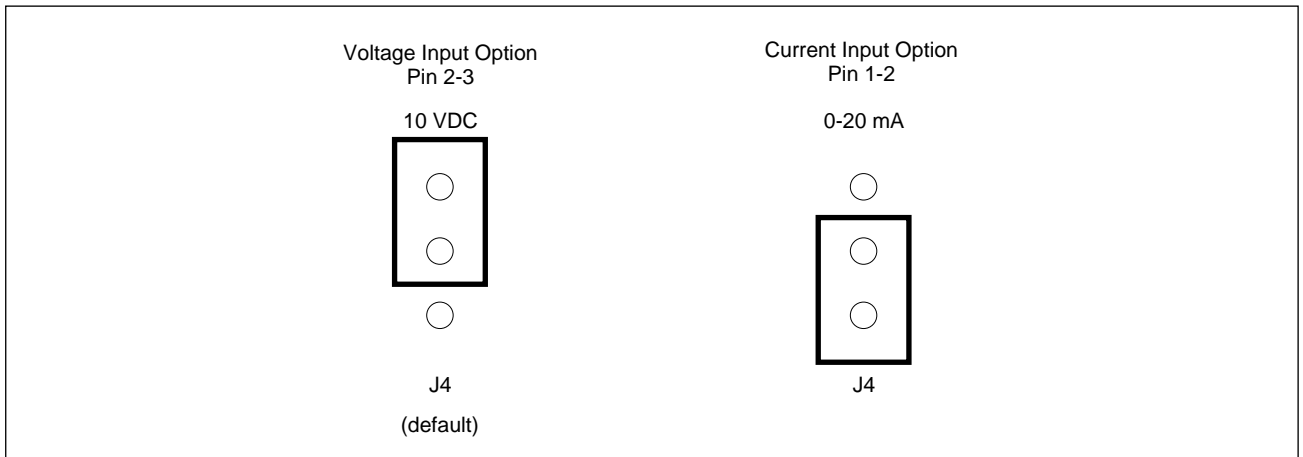

Figure 2.6 – Jumper J4 Settings for Analog Input Speed Reference

2.4.1.2 Analog Output Jumper (J17)

Jumper J17 is the analog output jumper. This jumper selects either a 0-10 VDC or 4-20 mA scaled signal output that is programmable for either speed or torque, parameter P.012. The jumper only selects a 0-10 VDC source voltage or 4-20 mA sink current to represent speed or torque. Note that the 4-20 mA current selection requires a power supply for operation as shown in table 7.8, terminals 10 and 11.

Use the following procedure to set jumper J17:



ATTENTION: DC bus capacitors retain hazardous voltages after input power has been disconnected. After disconnecting input power, wait five (5) minutes for the DC bus capacitors to discharge and then check the voltage with a voltmeter to ensure the DC bus capacitors are discharged before touching any internal components. Failure to observe this precaution could result in severe bodily injury or loss of life.

- Step 1. Turn off input power to the drive and wait five minutes.
- Step 2. Remove the cover from the drive by unscrewing the four attaching screws.
- Step 3. Verify that the DC bus voltage is zero by following the procedure in section 9.3.
- Step 4. Locate jumper J17 on the Regulator board. Refer to figure 2.5.
- Step 5. Locate pin 1 on jumper J17. Move the jumper to the desired setting as shown in figure 2.7.
- Step 6. Reattach the cover.
- Step 7. Reapply input power.
- Step 8. Verify that parameter P.012 is set correctly for either speed or torque.

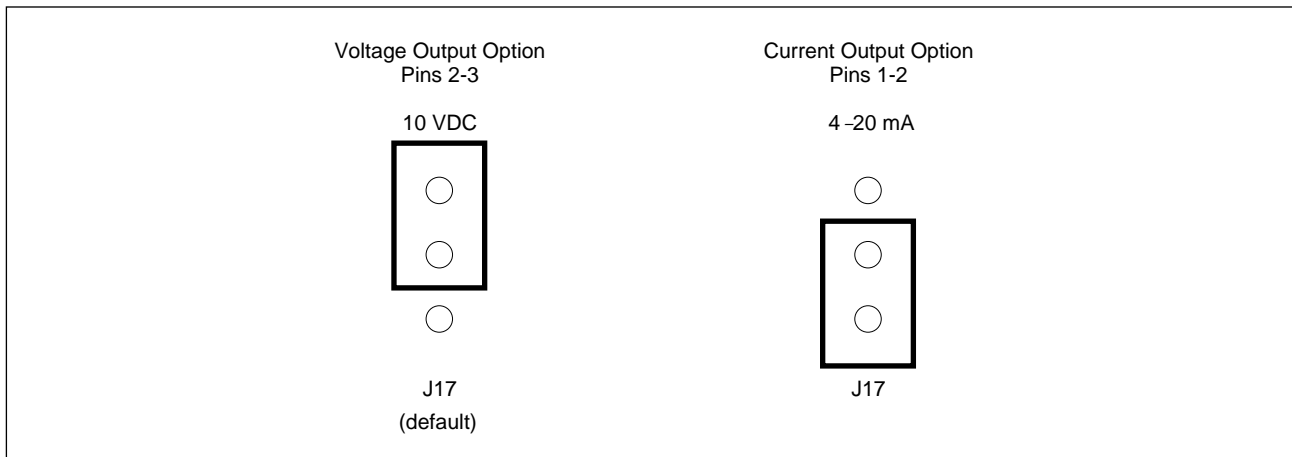

Figure 2.7 – Jumper J17 Settings for Analog Outputs

2.4.2 Wiring the Terminal Strip

The terminal strip on the Regulator board provides terminals for connecting customer I/O devices. See figures 2.5 and 2.8. The following terminals are provided:

- Terminals 1-3 : RS-232 connections
- Terminals 4-9 : encoder connections
- Terminals 10-11: analog output connections
- Terminals 12-15: analog speed/torque reference connections
- Terminals 16-25: 24 VDC digital input connections
- Terminals 26-27: snubber resistor braking control connections for older Snubber Resistor Braking Kits (for example, the M/N 2DB4010 series)
- Terminals 28-31: status relay connections

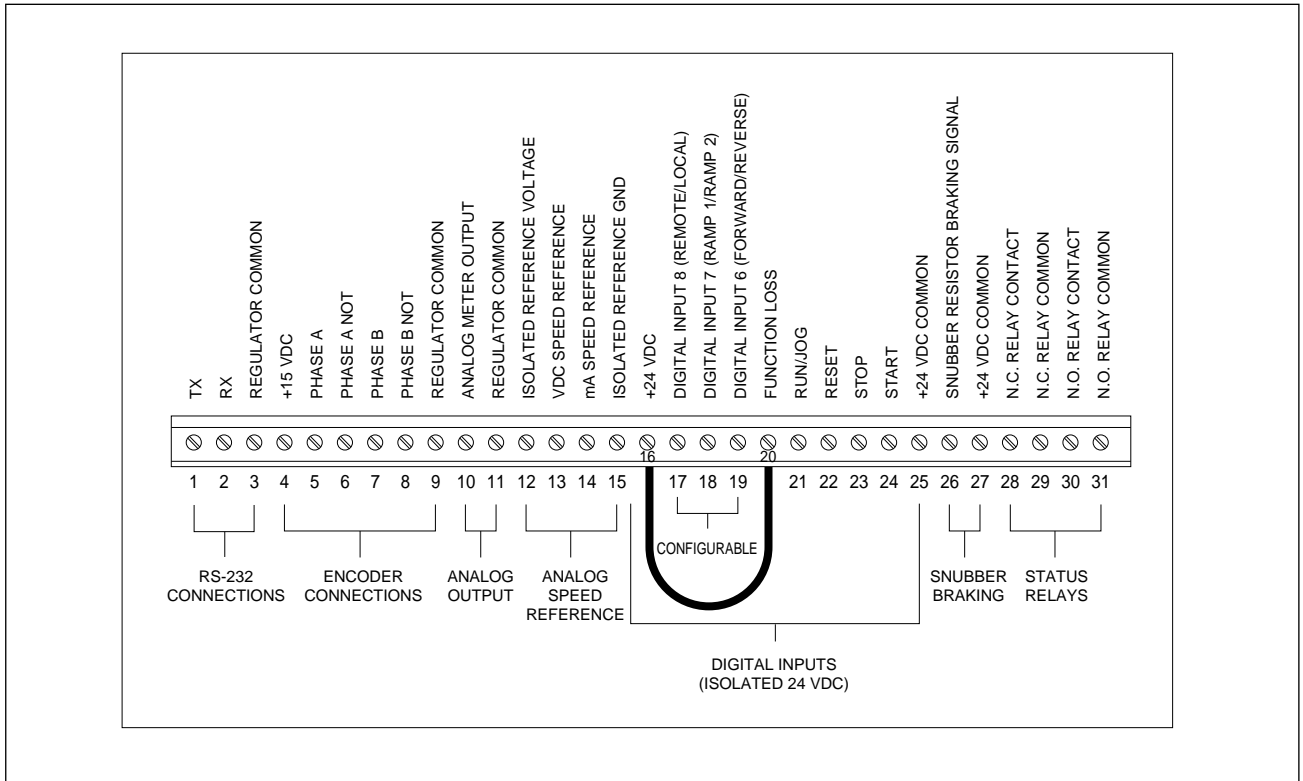

Figure 2.8 – Typical Terminal Strip Connections

2.4.3 RS-232 Communication Port

The Regulator board contains a 9-pin D-shell RS-232 communication port (J8). This port provides RS-232 communication between the GV3000/SE drive and a personal computer running the Control and Configuration (CS3000) software. See figure 2.5. Refer to instruction manual D2-3348, for more information about the CS3000 software.

2.4.4 Option Board Connector

The flat-ribbon cable connector (J3) on the left side of the Regulator board is a parallel bus connection port that provides a means of attaching optional boards such as the DeviceNet Option board, the RMI board, or the AutoMax Network Option board, or similar boards to the GV3000/SE drive. See figure 2.5. The option board is mounted below the Regulator board inside the drive. Refer to the appropriate board instruction for more information. Refer to section 2.5 of this manual for more information on optional drive kits.

2.4.5 Operator Interface Module Connector

The flat-ribbon connector J7 provides a means of attaching the optional Operator Interface Module (OIM). The OIM is available for use as a remote keypad for the GV3000/SE drive.

2.4.6 Keypad/Display

The front panel keypad/display is used to program and operate the GV3000/SE drive. See figure 2.9. Refer to the GV3000/SE Software Start-Up and Reference manual for more information.

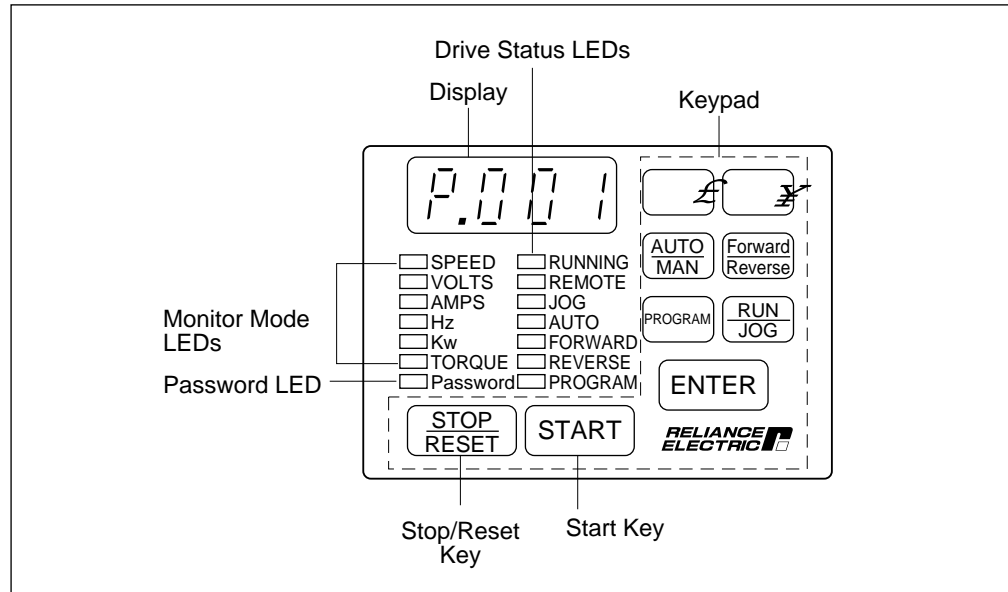

Figure 2.9 – Keypad/Display

2.5 Jumpers on Base Board (PISC-75/75A)

Jumpers JP1 through JP4 on the Base board (PISC-75/75A) are used for selection of current feedback gain as shown in table 2.2. On the Base board, there is another jumper, JP6, to be used for selection of ON/OFF level of precharge relay. Table 2.2 also shows the factory settings of these jumpers. For the locations of these jumpers, see figure 2.10.

Table 2.2 – Settings of Jumpers on Base Board

Jumpers	Description	Factory Setting
JP1 (for U-phase) JP2 (for V-phase) JP3 (for bus current) JP4 (for bus current)	These jumpers are used for selection of current feedback gain as follows: OPEN: for 75 HP and 100 HP units A: for 125 HP unit B: for 150 HP and 200 HP units	For 75 HP and 100 HP units: OPEN For 125 HP unit: A For 150 HP and 200 HP units: B
JP6	This jumper is used for selection of ON/OFF level of precharge relay as follows: A: ON at 350 V, OFF at 310 V B: ON at 440 V, OFF at 400 V	Set to A position

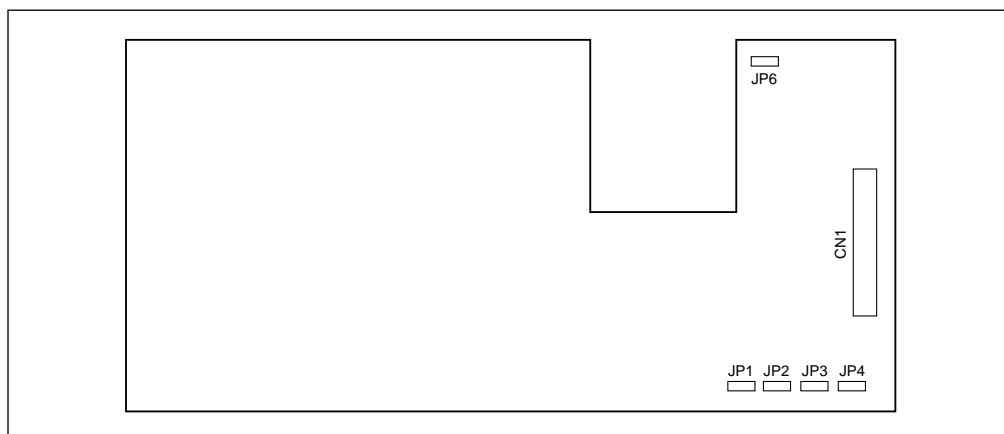

Figure 2.10 – Base Board Jumper Locations

2.6 Drive Kit Options

Table 2.3 provides a listing of the available GV3000/SE kit options.

Table 2.3 – Available Kits and Options

Kit Description ⁽¹⁾	Option Kit Model Number	Instruction Manual
Snubber Resistor Braking ⁽²⁾	2SR40700	D2-3401
Motor Encoder Cable	2TC3025 ⁽³⁾ 2TC3075 ⁽³⁾ 2TC4025 ⁽³⁾ 2TC4075 ⁽³⁾ 2TC4100 ⁽⁴⁾ 2TC4300 ⁽⁴⁾	D2-3305
ControlNet Network Option Board	2CN3000	D2-3390
Interbus-S Network Option Board	2NB3000	49'1333
AutoMax Network Option Board with 762 mm (30") of Cable	2AX3000	D2-3308
AutoMax RS-232 Adapter Cable	2CA3001	D2-3348
Super Remote Meter Interface (RMI)	2SI3000	D2-3341
DeviceNet Network Option Board	2DV3000	HE-HGV3DN
Operator Interface Module (OIM)	2RK3000	D2-3342
CS3000 Control and Configuration Software	2CS3000	D2-3348
CS3000 RS-232 Computer Cable	2CA3000	D2-3348
115 VDC Interface Option Board	2LB3000	D2-3376
PROFIBUS™ Interface Board	2PB3000	49.1355

⁽¹⁾ Consult the factory for options desired when not shown. Option kits are subject to change for feature or performance enhancements.

⁽²⁾ Up to two snubber kits can be connected to a drive in parallel.

⁽³⁾ These cables are for use with Reliance NEMA Vector Inverter Duty Motors (encoder connector and exposed wire pairs).

⁽⁴⁾ These cables are for use with Reliance NEMA Vector Inverter Duty Motors (exposed wire pairs on both ends).

Planning Before Installing

This chapter provides information that must be considered when planning a GV3000/SE drive installation. Installation site requirements, drive requirements, and wiring requirements are presented.



ATTENTION: Only qualified electrical personnel familiar with the construction and operation of this equipment and the hazards involved should install, adjust, operate, or service this equipment. Read and understand this manual and other applicable manuals in their entirety before proceeding. Failure to observe this precaution could result in severe bodily injury or loss of life.

ATTENTION: When the level-sense start feature is enabled (P.054 = ON), the user must ensure that automatic start up of the driven equipment will not cause injury to operating personnel or damage to the driven equipment. In addition, the user is responsible for providing suitable audible or visual alarms or other devices to indicate that this function is enabled and the drive may start at any moment. Refer to the GV3000/SE Software Start-Up and Reference manual for additional information. Failure to observe this precaution could result in severe bodily injury or loss of life.

ATTENTION: Use of power correction capacitors on the output of the drive can result in erratic operation of the motor, nuisance tripping, and/or permanent damage to the drive. Remove power correction capacitors before proceeding. Failure to observe this precaution could result in damage to, or destruction of, the equipment.

ATTENTION: The user is responsible for conforming with all applicable local, national, and international codes. Failure to observe this precaution could result in damage to, or destruction of, the equipment.

3.1 Requirements for the Installation Site

It is important to properly plan before installing a GV3000/SE drive to ensure that the drive's environment and operating conditions are satisfactory. Note that no devices are to be mounted behind the drive. This area must be kept clear of all control and power wiring. Read the following recommendations before continuing with drive installation.

3.1.1 Making Sure Environmental Conditions are Met

Before deciding on an installation site, consider the following guidelines:

- Verify that drives can be kept clean, cool, and dry.
- The area chosen should allow the space required for proper air flow as defined in section 3.1.3.

- Be sure that drives are away from oil, coolants, or other airborne contaminants.
- Do not install the drive above 1000 meters (3300 feet) without derating output power. For every 91.4 meters (300 feet) above 1000 meters (3300 feet), derate the output current 1%.
- Verify that the drive location will meet the environmental conditions specified in table 3.1.

Table 3.1 – Ambient Conditions

Condition	Specification
Operating Temperature (Ambient)	0° to 55°C (32° to 131°F)
Storage Temperature (Ambient)	-40° to +65°C (-40° to +149°F)
Humidity	5 to 95% (non-condensing)

3.1.2 Determining Total Area Required Based on Drive Dimensions

Drive dimensions and weights are listed in table 3.2. Overall drive dimensions are illustrated in figure 3.1 as an aid in calculating the total area required by the GV3000/SE drives.

Table 3.2 – Drive Dimensions and Weights

GV3000/SE Drive	Dim. H1	Dim. H2	Dim. H3	Dim. H4	Dim. W	Dim. D	Weight
75V40XX 100V40XX	634 mm 25.0"	654 mm 25.7"	594 mm 23.4"	696 mm 27.4"	235 mm 9.3"	354 mm 13.6"	35 kg 77 lbs
125V40XX	714 mm 28.1"	734 mm 28.9"	674 mm 26.5"	776 mm 30.6"	245 mm 9.6"	366 mm 14.4"	45 kg 99 lbs
150V40XX 200V40XX	875 mm 34.4"	914 mm 36.0"	774 mm 30.5"	866 mm 34.1"	281 mm 11.1"	366 mm 14.4"	55 kg 121 lbs

GV3000/SE Drive	Dim. A1	Dim. A2	Dim. A3	Dim. A4	Dim. B1	Dim. B2	Dim. C1	Dim. C2	Dim. C3	Dia. d
75V40XX 100V40XX	10 mm 0.4"	30 mm 1.2"	10 mm 0.4"	30 mm 1.2"	51 mm 2.0"	51 mm 2.0"	100 mm 3.9"	100 mm 3.9"	9 mm 0.35"	9 mm 0.35"
125V40XX	10 mm 0.4"	30 mm 1.2"	10 mm 0.4"	30 mm 1.2"	51 mm 2.0"	51 mm 2.0"	200 mm 7.9"	200 mm 7.9"	9 mm 0.35"	9 mm 0.35"
150V40XX	14 mm 0.6"	70 mm 2.8"	25 mm 1.0"	70 mm 2.8"	46 mm 1.8"	46 mm 1.8"	216 mm 8.5"	216 mm 8.5"	13 mm 0.51"	13 mm 0.51"

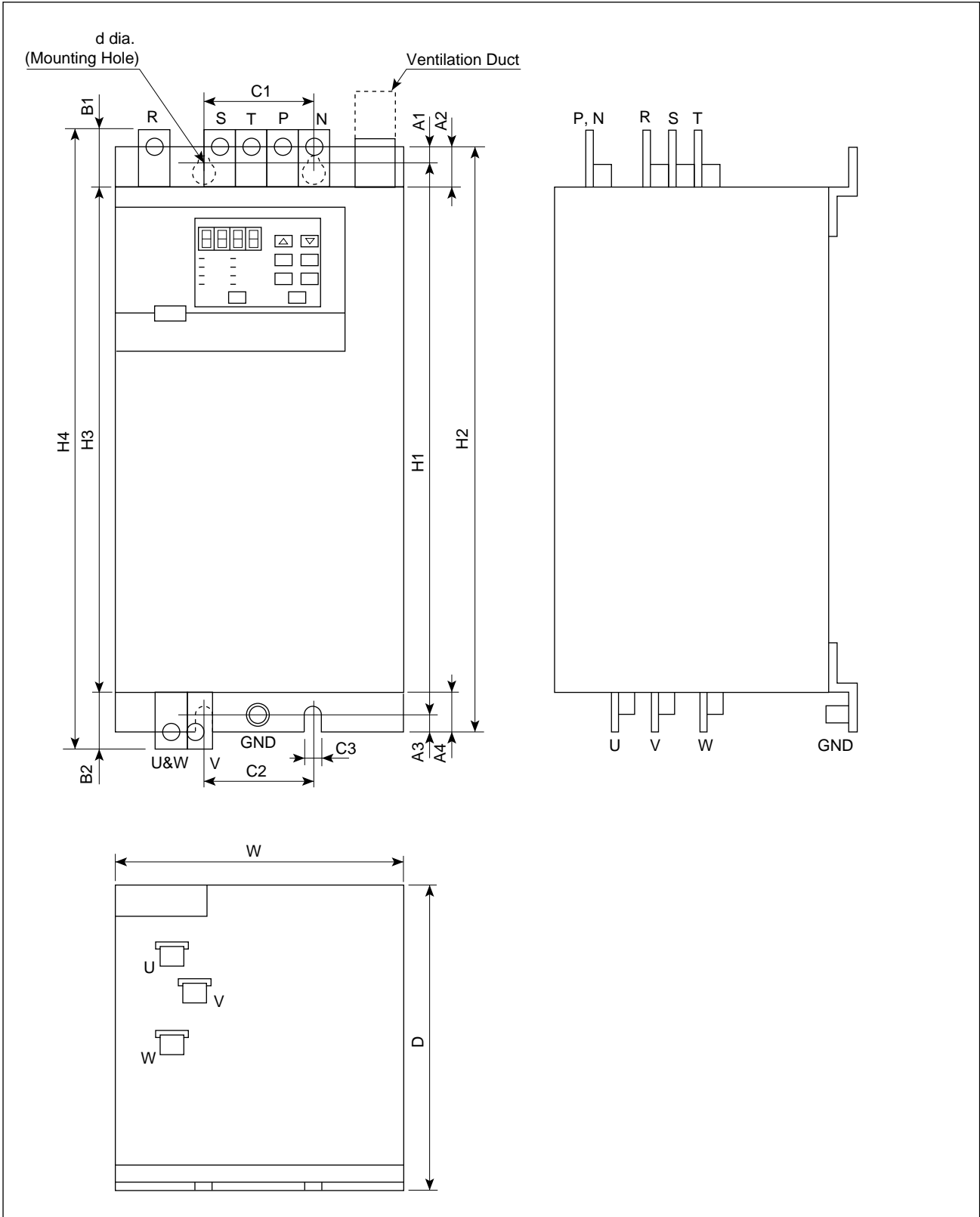

Figure 3.1 – Drive Dimensions

3.1.3 Verifying the Site Provides for Recommended Air Flow Clearances

Be sure there is adequate clearance for air ventilation around the drive. For best air movement, do not mount GV3000/SE drives directly above each other. Note that no devices are to be mounted behind the drive. This area must be kept clear of all control and power wiring. Refer to figure 3.2 for recommended air flow clearances.

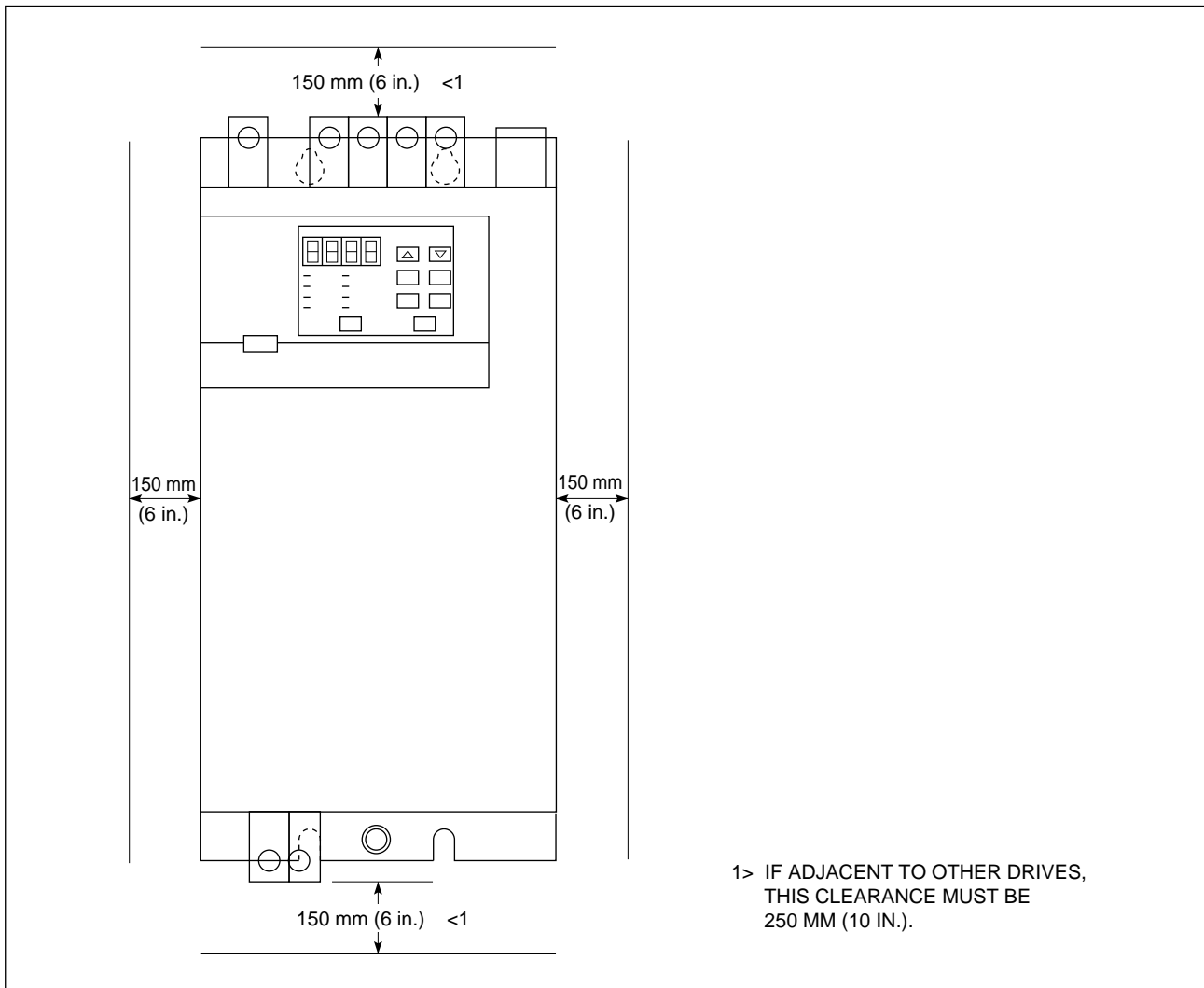

Figure 3.2 – Recommended Air Flow Clearances

When installing a GV3000/SE drive, prepare an opening for its ventilating duct at the top of the cabinet and, if necessary, provide an extension of the duct to connect between the opening and the duct.

3.1.4 Verifying Power Module AC Input Ratings Match Supplied Power

It is important to verify that plant power will meet the input power requirements of the GV3000/SE drive's Power Module circuitry. Refer to table 2.1 for input power rating specifications. Be sure input power to the drive corresponds to the drive nameplate voltage and frequency.

3.2 Wiring Requirements for the Drive

Certain drive requirements should be checked before continuing with the drive installation. Wire sizes, branch circuit protection, speed feedback (for FVC regulation), and E-stop wiring (see chapter 7), are all areas that need to be evaluated.

3.2.1 Meeting Terminal Strip Input and Output Specifications

The terminal strip on the Regulator board provides terminals for 24 VDC power for the eight remote control inputs. Refer to tables A.3 and A.4 for control input and output specifications.

3.2.2 Determining Wire Size Requirements

Wire size should be determined based on applicable local, national, and international codes (e.g., NEC/CEC regulations).



ATTENTION: The user is responsible for conforming with all applicable local, national, and international codes. Failure to observe this precaution could result in damage to, or destruction of, the equipment.

3.2.2.1 Recommended Power Wire Sizes

Input power wiring should be sized according to applicable codes to handle the drive's continuous-rated input current. Output wiring should be sized according to applicable codes to handle the drive's continuous-rated output current. See tables 3.3 to 3.5 for recommended power wire sizes.

Important: Use only copper (Cu) wire with a temperature rating of 60/75°C.

Table 3.3 – Recommended Power Wire Sizes for 75 and 100 HP Drives

Type of Wiring	Terminals	Size of Wire (Maximum)
AC Input Power	R/L1, S/L2, T/L3	2/0 AWG (or 60 mm ²)
Output Power	U/T1, V/T2, W/T3	
DC Input Power	P, N	

Table 3.4 – Recommended Power Wire Sizes for 125 HP Drive

Type of Wiring	Terminals	Size of Wire (Maximum)
AC Input Power	R/L1, S/L2, T/L3	4/0 AWG (or 150 mm ²)
Output Power	U/T1, V/T2, W/T3	
DC Input Power	P, N	

Table 3.5 – Recommended Power Wire Sizes for 150 and 200 HP Drives

Type of Wiring	Terminals	Size of Wire (Maximum)
AC Input Power	R/L1, S/L2, T/L3	350 Kcmil (or 200 mm ²)
Output Power	U/T1, V/T2, W/T3	
DC Input Power	P, N	

3.2.2.2 Recommended Control and Signal Wire Sizes

The recommended wire size to connect I/O signals to the terminal strip on the Regulator board are shown in table 3.6. Recommended terminal tightening torque is 0.5 Newton-meters (4.5 in-lb). Operator controls can be up to 303 meters (1000 feet) from the GV3000/SE drive.

Table 3.6 – Recommended Terminal Strip Wire Sizes

Terminals	Wire Size
1 to 31	20 to 14 AWG (or 0.5 to 2 mm ²)

3.2.2.3 Recommended Motor Lead Lengths

The following motor lead lengths are recommended to reduce line disturbances and noise. See figure 3.3.

- For applications using one motor, motor lead length should not exceed 76 meters (250 feet). Note that drives using vector regulation can only be connected to one motor at a time.
- For applications with multiple motors, total motor lead length should not exceed 76 meters (250 feet).

When total lead length exceeds 76 meters (250 feet), nuisance trips can occur, caused by capacitive current flow to ground. Note that these capacitively-coupled currents should be taken into consideration when working in areas where drives are running. If the motor lead length must exceed these limits, the addition of output line reactors or other steps must be taken to correct the problem. See table 3.7 and 3.8. Note that the motor lead lengths shown in table 3.7 are only guidelines. Your application may be restricted to shorter lead length due to:

- the type of wire
- the placement of wire (for example, in conduit or a cable tray)
- the type of line reactor
- the type of motor.

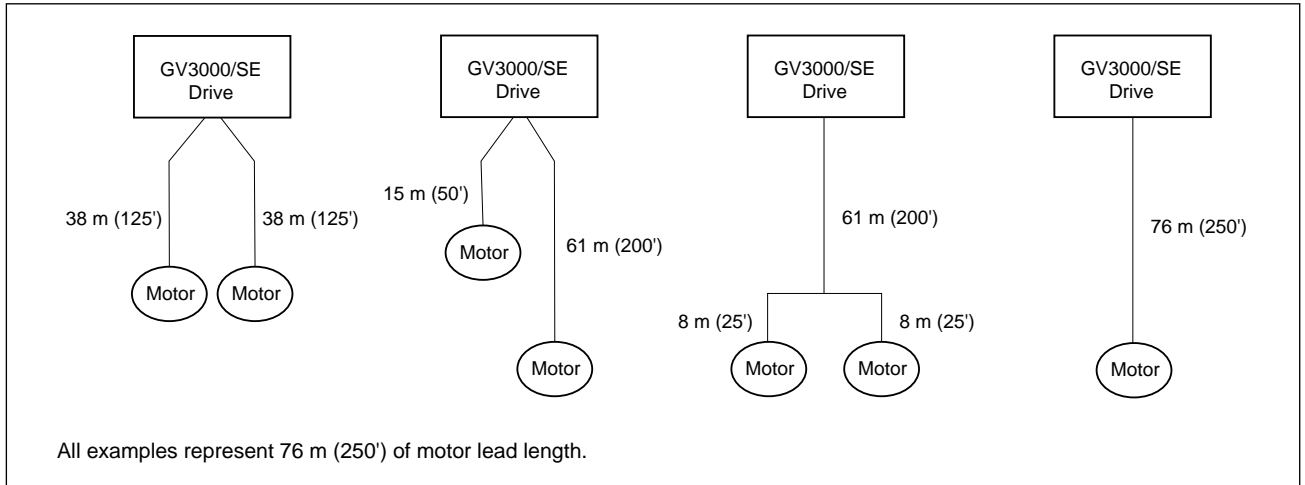

Figure 3.3 – How to Measure Motor Lead Lengths

Table 3.7 - Motor Lead Lengths

GV3000/SE HP Rating	Filter Type	Maximum Lead Length in Feet with 460 VAC Motor		
		Carrier Frequency		
		2 kHz	4 kHz	8 kHz
75 to 100	None	800	500	500
125 to 150		800	500	500
200		1000	1000	1000
75 to 100	A 5% MTE reactor/filter at the drive.	1000	1000	1000
125 to 150		1000	1000	1000
200		1000	1000	1000

Note that the lead lengths listed are valid with Reliance Electric inverter duty motors.

Table 3.8 - Reactors

GV3000/SE HP Rating	480 Volt 5% MTE Reactor		GV3000/SE HP Rating	480 Volt 5% MTE Reactor
75	RL-10003		150	RL-20003
100	RL-13003		200	RL-25003
125	RL-16003			

These part numbers are for a reactor with a capacitor filter.
MTE standard reactors can be used on GV3000/SE drives with carrier frequency settings up to 8 kHz.
All reactors listed are UL-recognized (UL-506 File #E53094) and CSA certified (CSA File #LR29753).

3.2.2.4 Recommended Serial Communication Cable Lengths

Connector J8 on the Regulator boards is an RS-232 serial communication port. This connector allows the GV3000/SE drive to communicate with external devices such as a personal computer using RS-232 protocol. See table A.5.

Two RS-232 cables are available from Reliance: a 3 meter (10 feet) D-shell 9-pin to 9-pin cable (M/N 2CA3000) and a 0.3 meter (1 foot) D-shell 9-pin to 25-pin adapter cable (M/N 2CA3001). User-constructed cables can be up to 15 meters (50 feet) in length.

Note that for communication between a GV3000/SE drive and a personal computer, the Control and Configuration software must also be used. Refer to instruction manual D2-3348 for more information about the CS3000 Software.

The Regulator boards have one set of RS-232 transmit/receive lines. These lines can be accessed by only one device at a time: connector J8, the RS-232 terminals (1-3) on the terminal strip, or an Operator Interface Module (OIM).

3.2.3 Selecting AC Input Line Branch Circuit Fuses, Circuit Breakers, and AC Reactors



ATTENTION: Most codes require that upstream branch circuit protection be provided to protect input power wiring. Install the fuses recommended in table 3.9. Do not exceed the fuse ratings. Failure to observe this precaution could result in damage to, or destruction of, the equipment.

Input line branch circuit protection fuses must be used to protect the input power lines. See figures 5.1 and 5.2. Recommended fuse values are shown in table 3.9. The input fuse ratings listed in table 3.9 are applicable for one drive per branch circuit. No other load may be applied to that fused circuit.

Table 3.9 – AC Input Line Fuse Selection Values

Model Number	Horsepower Rating	Input AC Fuse Rating ⁽¹⁾
75V4060	75 HP	175 A
100V4060	100 HP	250 A
125V4060	125 HP	300 A
150V4060	150 HP	400 A
200V4060	200 HP	450 A

⁽¹⁾ Recommended fuse type: UL Class J, 600V, time-delay, or equivalent.

AC reactor must be installed in the AC input line. Tables 3.10 and 3.11 show selection values for the circuit breakers and the AC reactors respectively.

Table 3.10 - Circuit Breaker Selection Values

Model Number	Horsepower Rating	Circuit Breaker Rating
75V4060	75 HP	125 A
100V4060	100 HP	150 A
125V4060	125 HP	200 A
150V4060	150 HP	250 A
200V4060	200 HP	300 A

Table 3.11 - AC Reactor Selection Values

Model Number	Horsepower Rating	AC Reactor
75V4060	75 HP	LS3-100/6-1 (100 A/216 μ H)
100V4060	100 HP	LS3-160/6-1 (160 A/132 μ H)
125V4060	125 HP	LS3-200/6-1 (200 A/108 μ H)
150V4060	150 HP	LS3-200/6-1 (200 A/108 μ H)
200V4060	200 HP	LS3-250/6-1 (250 A/84 μ H)

3.2.4 Meeting Encoder Specifications (FVC Regulation Only)

GV3000/SE drives set up for FVC regulation require an encoder for closed loop operation. Encoder specifications are provided in table A.6. Drives set up for V/Hz or SVC regulation do not require an encoder for feedback because they operate in open loop mode.

3.2.4.1 Encoder Wiring Guidelines

Encoder connections are considered signal level wiring and, therefore, must be run separate from control and power wiring. Reliance Electric recommends 18 AWG unshielded twisted pair wires with 2-3 twists per inch for applications to maximum distance of 303 meters (1000 feet). The recommended Reliance Electric part number is 417900-207CG, 18 AWG, 6 conductors (3 twisted pairs).

3.2.5 Verifying Power Module Output Current Rating is Greater Than Motor Full Load Amps

Verify that the GV3000/SE output current rating is greater than the motor's full load current (amps). Table 2.1 lists the output current values.

Mounting the Drive, Grounding, and Finding Wire Routing Locations

This chapter shows how to mount the drive and properly ground it.

4.1 Mounting the Drive

Attach the drive to the vertical surface selected using the four (4) mounting holes provided. In order to maintain a flat mounting surface and to ensure that bolt tightness is maintained, use washers under the bolt heads. Refer to figure 3.1 and table 3.2 for drive mounting dimensions. Use the following user-supplied mounting bolts and washers:

- 75 HP and 100 HP drive: M8 (5/16")
- 125 HP drive: M8 (5/16")
- 150 HP and 200 HP drives: M10 (3/8").

4.1.1 Verifying the Drive's Watts Loss Rating

When mounting the drive inside of another enclosure, you should determine the watts loss rating of the drive shown in table 2.1. This table lists the typical full load power loss watts value under all operating carrier frequencies. Ensure adequate ventilation is provided based on the drive's watts loss rating.

4.2 Routing Input, Motor Output, Ground, and Control Wiring for the Drive

All wiring should be installed in conformance with the applicable local, national, and international codes (e.g., NEC/CEC). Signal wiring, control wiring, and power wiring must be routed in separate conduits to prevent interference with drive operation. Note that no wires are to be routed behind the drive. Figure 4.1 shows the locations of the power terminals and the grounding terminals of the GV3000/SE drives.



ATTENTION: Do not route signal and control wiring with power wiring in the same conduit. This can cause interference with drive operation. Failure to observe this precaution could result in damage to, or destruction of, the equipment.

Do not route more than three sets of motor leads through a single conduit. This will minimize cross-talk that could reduce the effectiveness of noise reduction methods. If more than three drive/motor connections per conduit are required, shielded cable must be used. If possible, each conduit should contain only one set of motor leads.



ATTENTION: Unused wires in conduit must be grounded at both ends to avoid a possible shock hazard caused by induced voltages. Also, if a drive sharing a conduit is being serviced or installed, all drives using this conduit should be disabled to eliminate the possible shock hazard from cross-coupled motor leads. Failure to observe these precautions could result in bodily injury.

4.3 Grounding the Drive



ATTENTION: The user is responsible for conforming with all applicable local, national, and international codes. Failure to observe this precaution could result in damage to, or destruction of, the equipment.

Use the following steps to ground the drive:

- Step 1. Remove the drive's cover.
- Step 2. Run a suitable equipment grounding conductor unbroken from the drive's ground terminal to the motor's ground terminal and then to earth ground. See figures 4.1, 5.1 and 5.2.
- Step 3. Connect a suitable grounding conductor to the motor frame, the remote control station (if used), and the transformer. Run each conductor **unbroken** to earth ground.

When adding more than one grounding conductor wire to a single chassis ground, twist the conductors together.

- Step 4. Reattach the drive's cover.

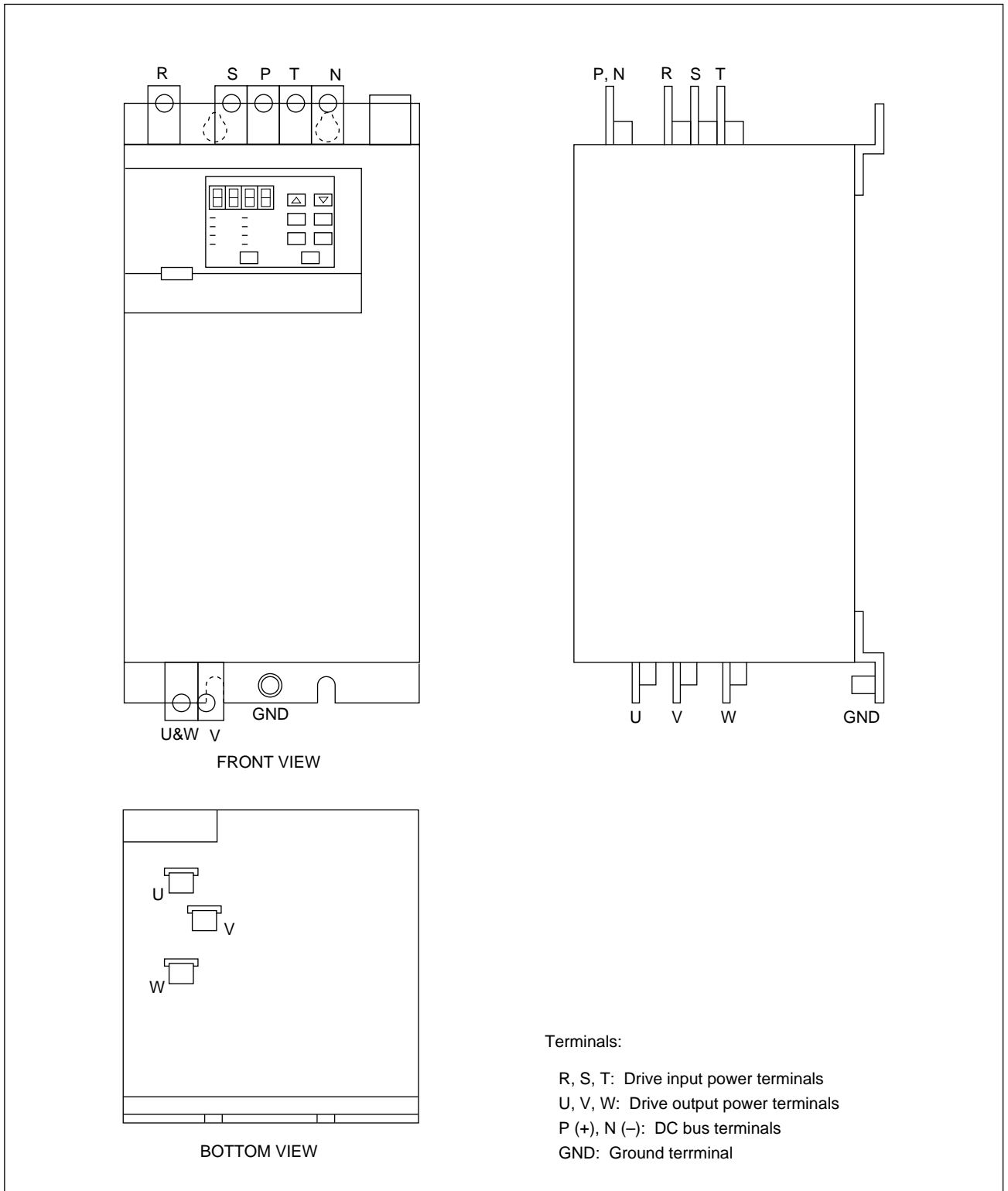

Figure 4.1 – Terminal Locations

Installing Input Power Wiring

This chapter describes incoming line components and how to install them.

5.1 Installing Transformers and Reactors (Optional)

Input isolation transformers might be needed to help eliminate the following:

- Damaging line voltage transients from reaching the drive.
- Line noise from the drive back to the incoming power source.
- Damaging currents that could develop if a point inside the drive becomes grounded.

Observe the following guidelines when installing an isolation transformer:

- A power disconnecting device must be installed between the power line and the primary of the transformer.
- If the power disconnecting device is a circuit breaker, the circuit breaker trip rating must be coordinated with the inrush current (10 to 12 times full load current) of the transformer.
- An additional impedance is required between the drive and the transformer. An appropriate three-phase AC line reactor should be used as shown in table 5.1.



ATTENTION: Distribution system capacity above the maximum recommended system KVA (1000 KVA for 460 VAC) requires the use of an isolation transformer, a line reactor, or other means of adding similar impedance to the drive power input. Failure to observe these precautions could result in damage to, or destruction of, the equipment.

ATTENTION: When the AC line is shared directly with other SCR-rectified drives, an optional snubber resistor braking kit might be required to alleviate excess DC bus voltage. Failure to observe these precautions could result in damage to or destruction of the equipment.

The GV3000/SE AC line distribution system capacity is 1000 KVA, three-phase with 30,000 amps symmetrical fault current capacity with a line impedance of less than 5%. The symmetrical fault current may be increased to 85,000 amps if the appropriate three-phase AC line reactor is used as shown in table 5.1.

Table 5.1 – AC Line Reactors

GV3000/SE Drive	Line Reactor Inductance (+/-10%)
75 HP	216 μ H
100 HP	132 μ H
125 HP	108 μ H
150 HP	108 μ H
200 HP	84 μ H

5.2 Installing Fuses for Branch Circuit Protection

Install the required, user-supplied branch circuit protection fuses according to the applicable local, national, and international codes (e.g., NEC/CEC). The fuses must be installed in the line before the drive input terminals. See figures 5.1 and 5.2. Fuse value selections are provided in table 3.7.



ATTENTION: Most codes require that upstream branch protection be provided to protect input power wiring. Failure to observe this precaution could result in severe bodily injury or loss of life.

5.3 Installing a Required External/Separate Input Disconnect

An input disconnect must be installed in the line before the drive input terminals in accordance with local, national, and international codes (e.g., NEC/CEC). The disconnect should be sized according to the in-rush current as well as any additional loads the disconnect might supply. The trip rating for the inrush current (10-12 times full load current) should be coordinated with that of the input isolation transformer, if used. Refer to section 5.1 for additional information.

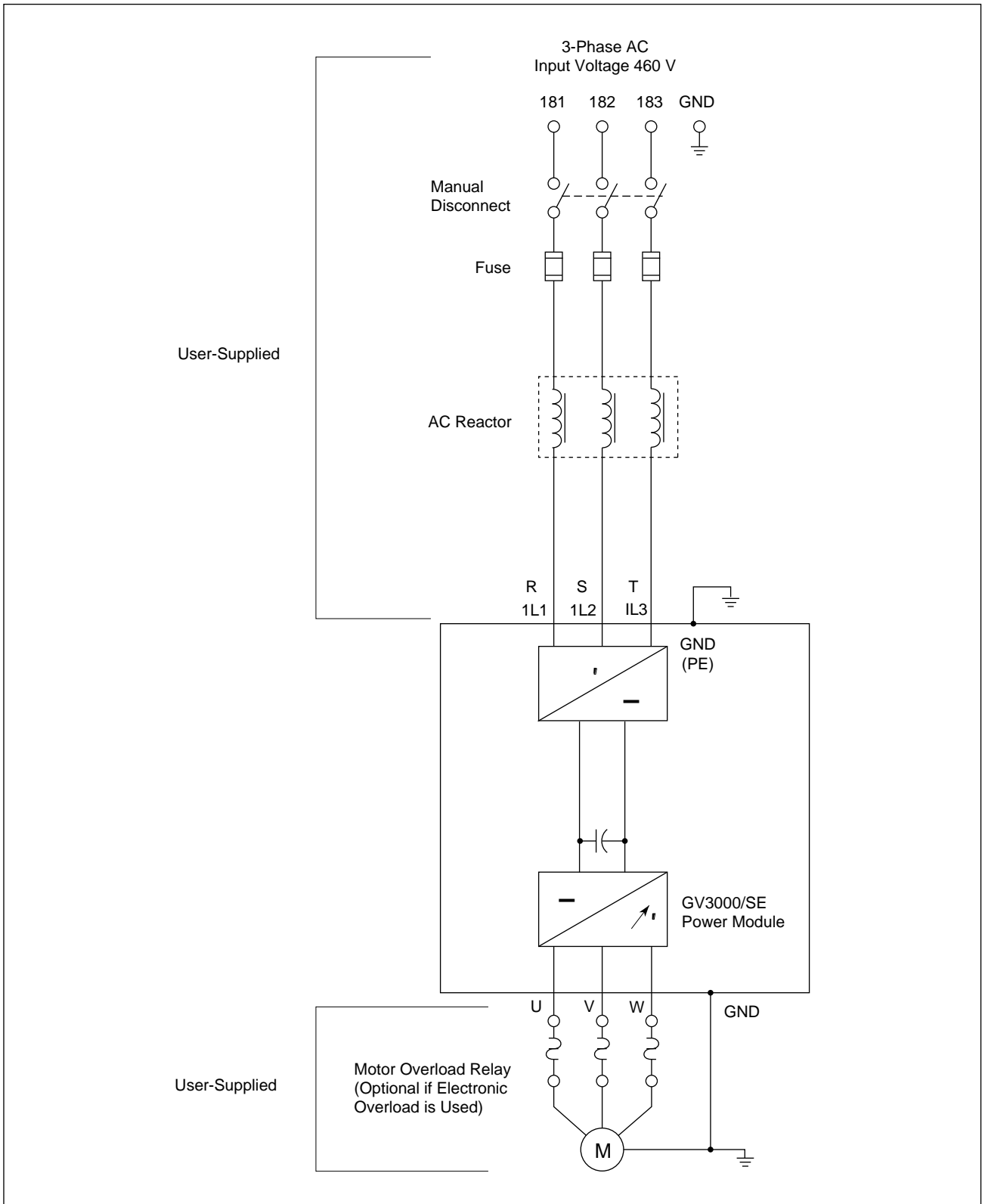

Figure 5.1 – Typical AC Input Electrical Connections

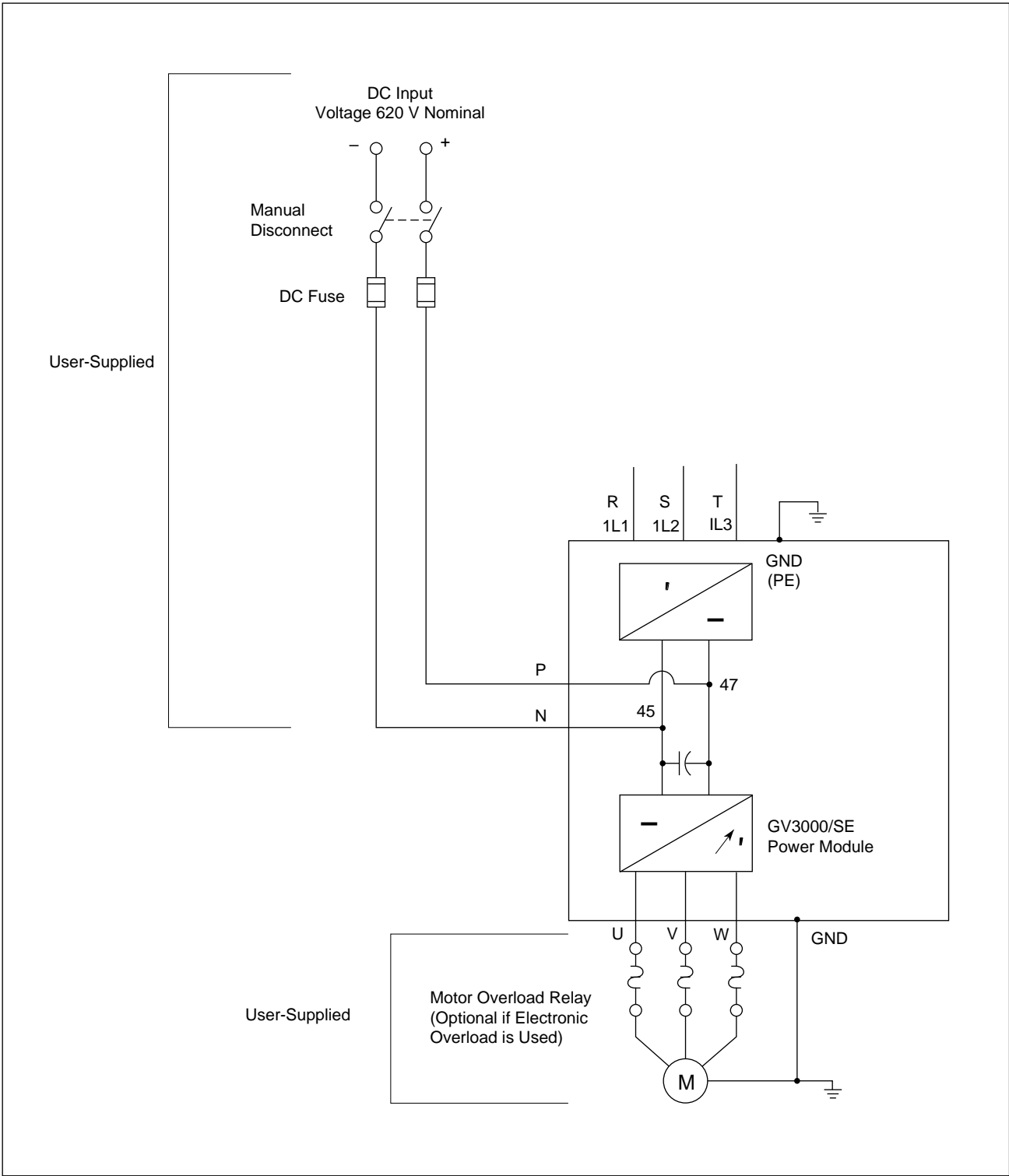

Figure 5.2 – Typical DC Bus Electrical Connections

5.4 Installing Power Wiring from the AC Input Line to the Drive's Power Terminals

Use the following steps to connect AC input power to the drive:

Step 1. Wire the AC input power leads. Tables 3.3 and 3.4 contain the recommended power wiring sizes.



ATTENTION: Do not route signal and control wiring in the same conduit with power wiring. This can cause interference with drive operation. Failure to observe this precaution could result in damage to, or destruction of, the equipment.

Step 2. Connect the three-phase AC input power leads (three-wire 380-460 VAC) to terminals R/L1, S/L2, T/L3. Refer to figure 4.1 for the locations of the terminal.

Step 3. Tighten the AC input power terminals to 9.8-11.7 Newton-meters (87-104 lb-in) for 75-200 HP drives.

5.5 Installing Power Wiring from an External DC Bus to the Drive's Internal DC Bus Terminals

Use the following steps to connect DC input power to the drive:

Step 1. Wire the DC input power leads. Tables 3.3 and 3.4 contain the recommended power wiring sizes.



ATTENTION: Do not route signal and control wiring in the same conduit with power wiring. This can cause interference with drive operation. Failure to observe this precaution could result in damage to, or destruction of, the equipment.

ATTENTION: If the GV3000/SE drive is connected to an external DC bus, the user is responsible for DC bus short-circuit protection. Failure to observe this precaution could result in damage to, or destruction of, the equipment.

Step 2. Connect the DC input power leads (two-wire 620 VDC nominal) to terminals + and -. See figure 4.1 for the locations of the terminals.

Note that the maximum discharge rate of the DC bus supply should be 200 V/second.

Step 3. Tighten the DC input power terminals to 9.8-11.7 Newton-meters (87-104 lb-in) for 75-200 HP drives.

Installing Output Power Wiring

This chapter provides instructions on wiring output contactors, motor overload protection, and output wiring to the motor.

6.1 Installing Output Contactors (Optional)

Output contactors provide a positive means of disconnecting the motor from the drive. If the application requires the use of output contactors, contact Reliance Electric for assistance.

6.2 Installing Mechanical Motor Overload Protection (Optional)

To provide the motor with overload protection, local, national, and international codes (e.g., NEC/CEC) require that a motor thermostat, internal to the motor, be installed or an electronic thermal motor overload relay, sized to protect the motor, be installed between the motor and the drive's output terminals.

The Motor Overload Enable parameter (P.040) can be used in place of the electronic thermal motor overload relays in single motor applications. Note, however, that temperature measuring devices integral to the motor are the best way to thermally protect AC motors under all conditions. Parameter P.040 must be enabled to provide overload protection. Refer to the GV3000/SE Software Start-Up and Reference manual for more information.

In multiple motor applications (V/Hz regulation only), each motor must have its own user-supplied overload protection.

6.3 Installing Output Wiring from the Drive Output Terminals to the Motor

Use the following steps to connect the AC output power wiring from the drive to the motor:

Step 1. Wire the three-phase AC output power motor leads. Tables 3.3 and 3.4 contain the recommended power wiring sizes.

Do not route more than three sets of motor leads through a single conduit. This will minimize cross-talk that could reduce the effectiveness of noise reduction methods. If more than three drive/motor connections per conduit are required, shielded cable must be used. If possible, each conduit should contain only one set of motor leads.



ATTENTION: Do not route signal and control wiring with power wiring in the same conduit. This can cause interference with drive operation. Failure to observe this precaution could result in damage to, or destruction of, the equipment.

ATTENTION: Unused wires in conduit must be grounded at both ends to avoid a possible shock hazard caused by induced voltages. Also, if a drive sharing a conduit is being serviced or installed, all drives using this conduit should be disabled to eliminate the possible shock hazard from cross-coupled motor leads. Failure to observe these precautions could result in bodily injury.

- Step 2. Connect the three-phase AC output power motor leads to terminals U/T1, V/T2, W/T3. See Figure 4.1 for the locations of the terminals.
- Step 3. Tighten the three-phase AC output power terminals to 9.8-11.9 Newton-meters (87-104 lb-in) for 75-200 HP drives.

CHAPTER 7

Wiring the Regulator Board Terminal Strip

This chapter describes how to wire the Regulator board terminal strip for stop, encoder feedback, and remote control signals.

The signals available through the terminal strip are shown in tables 7.1 to 7.7 and figures 7.1 and 7.2. Table 7.8 provides additional information.

Note that when the Control Source parameter (P.000) is set to remote (rE), the drive will be controlled by the signals connected to the terminal strip. Refer to the GV3000/SE Software Start-Up and Reference manual for more information on how parameter P.000 is used to specify where the drive is controlled from.

Table 7.1 – RS-232 Connections (Terminals 1-3)

Terminal #	Signal
1	Transmit (Tx)
2	Receive (Rx)
3	Regulator Common

Notes: The RS-232 terminals should only be used when the RS-232 communication port (J8) or an Operator Interface Module (OIM) are not being used, as all three devices use the same transmit/receive lines.

Table 7.2 – Encoder Connections (Terminals 4-9)

Terminal #	Signal
4	+15 VDC
5	Phase A
6	Phase A Not
7	Phase B
8	Phase B Not
9	Regulator Common

Notes: An encoder feedback device must be installed if FVC regulation is used.

Table 7.3 – Analog Output Connections (Terminals 10 and 11)

Terminal #	Signal
10	Analog Meter Output
11	Regulator Common
<p>Notes: The output of this terminal is either 0-10 VDC or 4-20 mA as determined by the setting of jumper J17 on the Regulator board. The analog output must also be programmed via parameter P.012 for an indication of speed and direction or percent of torque.</p>	

Table 7.4 – Analog Speed/Torque Reference Connections (Terminals 12-15)

Terminal #	Signal
12	Isolated Reference Voltage
13	VDC Speed/Torque Reference
14	mA Speed/Torque Reference
15	Isolated Reference Common
<p>Notes: The analog speed/torque (P.008/U.000) reference is either +/-10 VDC or +/-20 mA, as determined by the setting of jumper J4 on the Regulator board. The analog reference can be adjusted using parameters P.009, P.010, and P.011.</p>	

Table 7.5 – Digital Input Connections (Terminals 16-25)

Terminal #	Signal
16	+24 VDC (Current Limited) (For remote control digital inputs only)
17	Digital Input 8 (Remote/Local) - Programmable
18	Digital Input 7 (Ramp 1/Ramp 2) - Programmable
19	Digital Input 6 (Forward/Reverse) - Programmable
20	Function Loss
21	Run/Jog
22	Reset
23	Stop
24	Start
25	+24 VDC Common
<p>Notes: When a user-installed function loss input, a coast-to-stop push-button, or another external interlock is installed, the factory-installed jumper connecting terminals 16 and 20 must be removed so that a contact, when open, will stop the drive.</p> <p>Terminals 17, 18, and 19 (remote control inputs 8, 7, and 6) are programmed using parameters P.007, P.008, and P.031 through P.038. Factory default settings are shown here in parentheses. Refer to the GV3000/SE Software Start-Up and Reference manual for more information.</p>	

Table 7.6 – Snubber Resistor Braking Connections (Terminals 26 and 27)

Terminal #	Signal
26	Snubber Resistor Braking Signal
27	+24 VDC Common
Notes: These terminals are used with older Snubber Resistor Braking kits that require a gate turn-on signal from the drive (for example, the M/N 2DB4010 series).	

Table 7.7 – Status Relay Connections (Terminals 28-31)

Terminal #	Signal
28	N.C. Relay Contact
29	N.C. Relay Common
30	N.O. Relay Contact
31	N.O. Relay Common
Notes: Relay contact closure is programmable through parameter P.013. Refer to the GV3000/SE Software Start-Up and Reference manual for more information.	

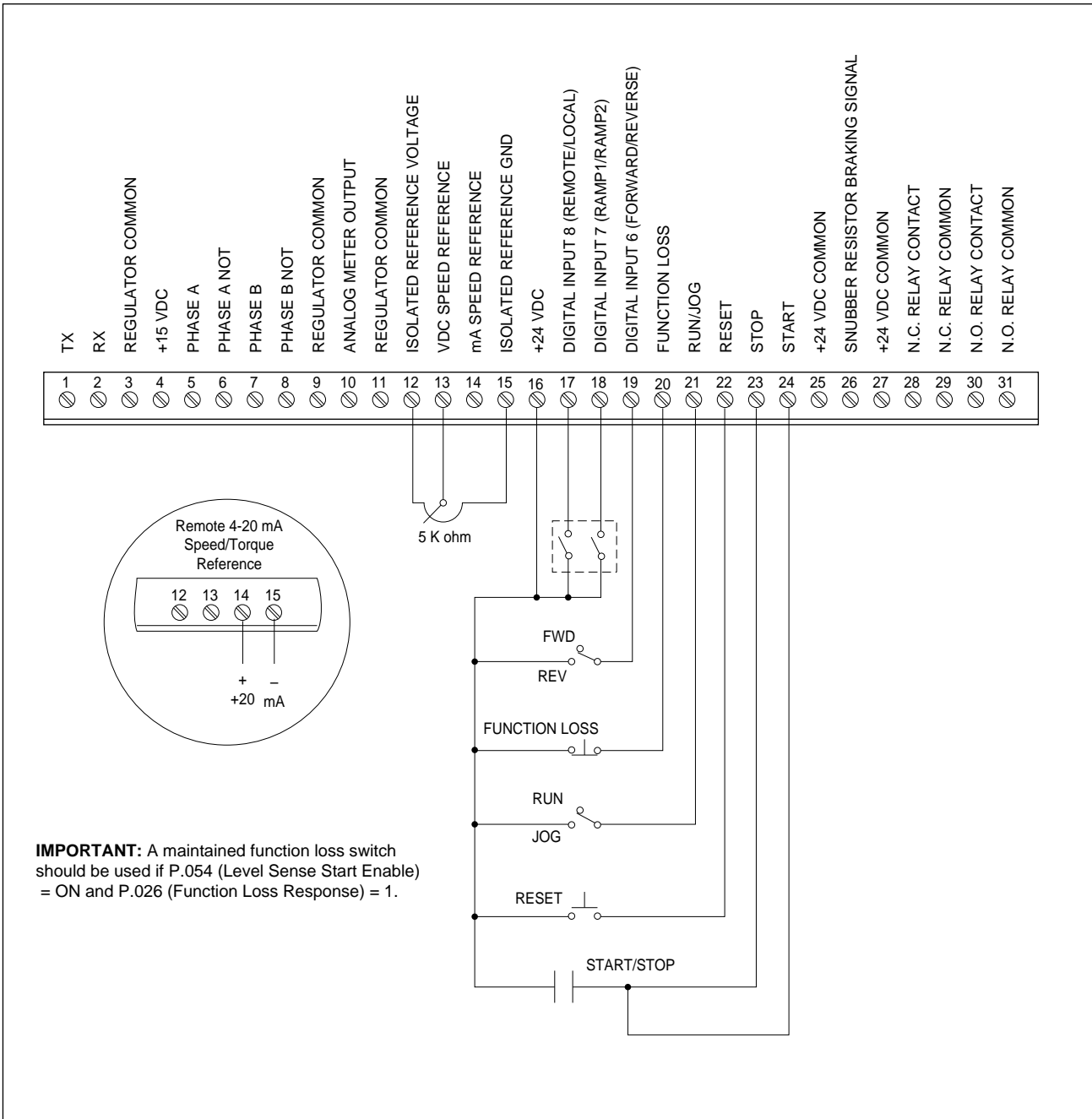

Figure 7.1 – Two-Wire Start/Stop Sample Control Wiring

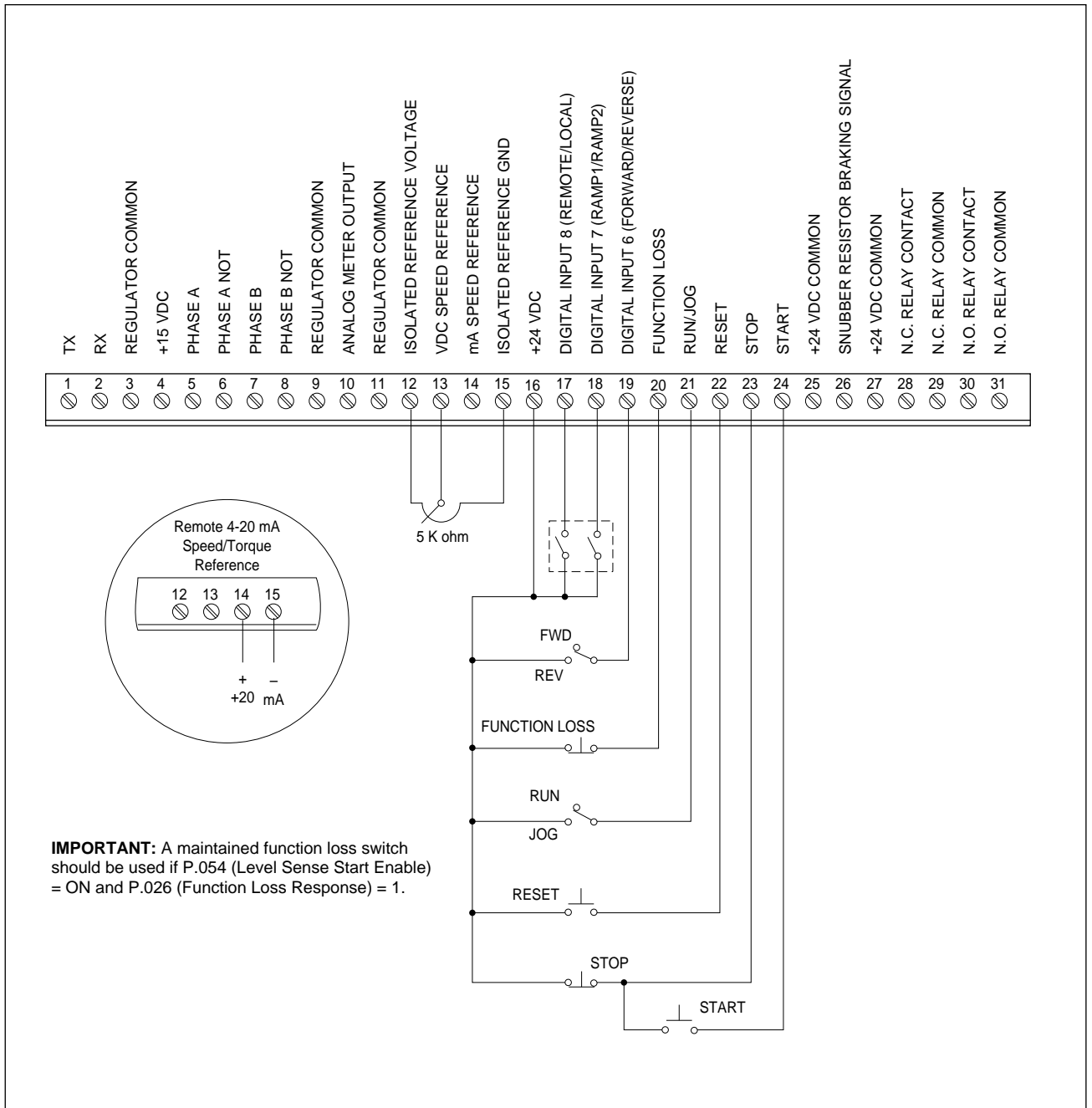

Figure 7.2 – Three-Wire Start/Stop Sample Control Wiring

7.1 Stopping the Drive



ATTENTION: The user must provide an external, hardwired emergency stop circuit outside of the drive circuitry. This circuit must disable the system in case of improper operation. Uncontrolled machine operation may result if this procedure is not followed. Failure to observe this precaution could result in bodily injury.

ATTENTION: When P.055 is set to ON, the STOP/RESET key is functional only from the selected control source. As a safety precaution, Reliance Electric recommends that an emergency stop push button be located near the drive in an easily accessible location. As a further safety precaution, you should post a warning on the drive to alert personnel that the STOP/RESET key is not functional. Failure to observe this precaution could result in severe bodily injury or loss of life.

Depending upon the requirements of the application, the GV3000/SE drive can be programmed to provide either a coast-to-rest or a ramp-to-rest operational stop without physical separation of the power source from the motor. A coast-to-rest stop turns off the transistor power device drivers. A ramp-to-rest stop fires the transistor power device drivers until the motor comes to a stop, and then turns off the power devices. The user can also program zero speed with power maintained to the motor, but in this condition, the drive is not actually stopped. See the description of terminal 23 and 24 or Stop Type (P.025) for more information on how to program the operational stop.

In addition to the operational stop, the user must provide a hardwired emergency stop external to the drive. The emergency stop circuit must contain only hardwired electromechanical components. Operation of the emergency stop must not depend on electronic logic (hardware or software) or on the communication of commands over an electronic network or link.

Parameter P.055 (STOP/RESET Key Disable) can be used to change the operation of the STOP/RESET key. See the parameter P.055 description in the software manual for more information.

Note that the user-installed hardwired emergency stop may be used at any time to stop the drive.

7.2 Wiring the Encoder Feedback Device (FVC Regulation Only)

If the GV3000/SE drive is programmed to provide FVC regulation, an encoder must be installed. Drives using V/Hz or SVC regulation do not require the use of an encoder feedback device. The encoder connects to terminals 4 to 9 of the regulator's terminal strip:

- Terminal 4: Encoder Supply +15 VDC (250 mA capacity)
- Terminal 5: Encoder Phase A Differential Input
- Terminal 6: Encoder Phase A Not Differential Input

- Terminal 7: Encoder Phase B Differential Input
- Terminal 8: Encoder Phase B Not Differential Input
- Terminal 9: Encoder/Regulator Common

Use the following procedure to connect an encoder to the regulator's terminal strip:

Step 1. Connect the encoder's wires to terminals 4 through 9 of the terminal strip. See figure 7.3. See table A.6 for additional encoder specifications. Refer to section 3.2.4.1 for encoder wiring guidelines.

Step 2. Set the following parameters to establish the maximum motor speed:

- P.004: Maximum Speed
- U.001: Encoder PPR
- U.002: Motor Poles
- U.003: Motor Nameplate Base Frequency
- U.005: Motor Nameplate RPM
- U.017: Motor Top Speed

Refer to the GV3000/SE Software Start-Up and Reference manual for more information.

REAR OF ENCODER CONNECTOR
 Tamagawa FA Style
 (M/N 2TC4025 and 2TC4075)

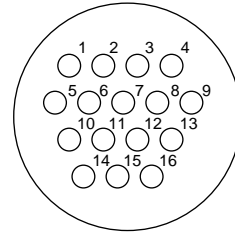

Regulator Terminal Strip		Connector/Cable End
Terminal 6	WHITE/ORANGE	Pin 1 Phase A
Terminal 5	ORANGE	Pin 2 Phase A Not
Terminal 4	BROWN	Pin 6 0 VDC
Terminal 9	WHITE/BROWN	Pin 12 +15 VDC
Terminal 8	WHITE/GREEN	Pin 8 Phase B
Terminal 7	GREEN	Pin 9 Phase B Not

REAR OF ENCODER CONNECTOR
 Dynapar H20 Style
 (M/N 2TC3025 and 2TC3075)

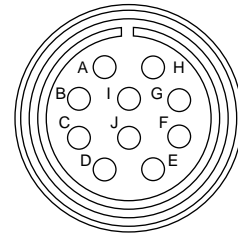

Regulator Terminal Strip		Connector/Cable End
Terminal 6	WHITE/ORANGE	Pin A Phase A
Terminal 5	ORANGE	Pin H Phase A Not
Terminal 4	RED	Pin F 0 VDC
Terminal 9	WHITE/RED	Pin D +15 VDC
Terminal 7	BROWN	Pin B Phase B
Terminal 8	WHITE/BROWN	Pin I Phase B Not

REAR OF ENCODER CONNECTOR
 Lakeshore SL56 and RL67 Style Slim-Tach Encoder

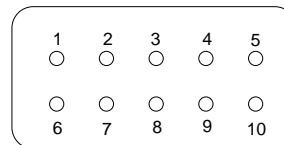

Regulator Terminal Strip		Connector/Cable End
Terminal 6	WHITE/ORANGE	Pin 3 Phase A
Terminal 5	ORANGE	Pin 8 Phase A Not
Terminal 4	RED	Pin 1 0 VDC
Terminal 9	WHITE/RED	Pin 6 +15 VDC
Terminal 7	BROWN	Pin 2 Phase B
Terminal 8	WHITE/BROWN	Pin 7 Phase B Not

Figure 7.3 - Encoder Wiring Connections

7.3 Wiring the Signal and Control I/O

Wire the drive's signal and control I/O to the terminal strip as shown in table 7.8.

Table 7.8 – Wiring Signal and Control I/O to the Terminal Strip





Terminal Number	Description	Parameters/Wiring Connections						
Wiring RS-232 Signals								
1	RS-232 Transmit	<p>Note that RS-232 communication between the GV3000/SE drive and a personal computer requires the use of the Control and Configuration software. Refer to instruction manual D2-3348 for more information.</p> <p>These terminals should only be used when the RS-232 port (J8) or an Operator Interface Module (OIM) are not being used, as all three devices use the same transmit/receive lines.</p> <div style="border: 1px solid black; padding: 5px; margin: 10px 0;"> <table style="width: 100%; border-collapse: collapse;"> <tr> <td style="width: 50%; border-right: 1px solid black; padding: 5px;"> <p style="text-align: center;">TERMINAL STRIP</p>  </td> <td style="width: 50%; padding: 5px;"> <p style="text-align: center;">PERSONAL COMPUTER</p> <p style="text-align: center;">25 PIN D-SHELL, MALE –OR– 9 PIN D-SHELL, PLUG</p>  </td> </tr> <tr> <td style="border-right: 1px solid black; padding: 5px;"> <p>TXD [DATA OUT] TERMINAL 1 ○</p> <p>RXD [DATA IN] TERMINAL 2 ○</p> <p>COMMON TERMINAL 3 ○</p> </td> <td style="padding: 5px;"> <p>○ PIN-2 RXD [DATA IN]</p> <p>○ PIN-3 TXD [DATA OUT]</p> <p>○ COMMON</p> <p>○ PIN-7 (25-PIN D-SHELL)</p> <p style="text-align: center;">–OR–</p> <p>○ PIN-5 (9-PIN D-SHELL)</p> </td> </tr> <tr> <td colspan="2" style="text-align: center; padding: 5px;"> <p>WIRE LENGTH – 50 FEET [MAX]</p> </td> </tr> </table> </div>	<p style="text-align: center;">TERMINAL STRIP</p> 	<p style="text-align: center;">PERSONAL COMPUTER</p> <p style="text-align: center;">25 PIN D-SHELL, MALE –OR– 9 PIN D-SHELL, PLUG</p> 	<p>TXD [DATA OUT] TERMINAL 1 ○</p> <p>RXD [DATA IN] TERMINAL 2 ○</p> <p>COMMON TERMINAL 3 ○</p>	<p>○ PIN-2 RXD [DATA IN]</p> <p>○ PIN-3 TXD [DATA OUT]</p> <p>○ COMMON</p> <p>○ PIN-7 (25-PIN D-SHELL)</p> <p style="text-align: center;">–OR–</p> <p>○ PIN-5 (9-PIN D-SHELL)</p>	<p>WIRE LENGTH – 50 FEET [MAX]</p>	
<p style="text-align: center;">TERMINAL STRIP</p> 	<p style="text-align: center;">PERSONAL COMPUTER</p> <p style="text-align: center;">25 PIN D-SHELL, MALE –OR– 9 PIN D-SHELL, PLUG</p> 							
<p>TXD [DATA OUT] TERMINAL 1 ○</p> <p>RXD [DATA IN] TERMINAL 2 ○</p> <p>COMMON TERMINAL 3 ○</p>	<p>○ PIN-2 RXD [DATA IN]</p> <p>○ PIN-3 TXD [DATA OUT]</p> <p>○ COMMON</p> <p>○ PIN-7 (25-PIN D-SHELL)</p> <p style="text-align: center;">–OR–</p> <p>○ PIN-5 (9-PIN D-SHELL)</p>							
<p>WIRE LENGTH – 50 FEET [MAX]</p>								
2	RS-232 Receive							
3	RS-232 Signal/Regulator Common							
Wiring Encoder Inputs								
4-9	Encoder Wiring	See section 7.2.						

Table 7.8 – Wiring Signal and Control I/O to the Terminal Strip (Continued)

Terminal Number	Description	Parameters/Wiring Connections
Wiring Analog Outputs		
10	0-10 VDC or 4-20 mA Analog Output Reference	<p>The setting of parameter P.012 selects the terminal strip analog output source (either speed or torque). Jumper J17 must also be set. See figure 2.7.</p>
11	Regulator Common	<p>The 4-20 mA current selection requires a power supply for operation. The power can be sourced from the encoder supply, terminal 4 (15 VDC), or from an external 15 V power supply. Note that the maximum supply current from terminal 4 is 250 mA (encoder and current source) at 15 V. Terminals 9 and 11 are internally connected.</p> <div style="text-align: right; margin-right: 100px;">Terminal Strip</div>  <p style="text-align: center;">Load (Meter or Analog Input)</p> <p style="text-align: center;">+ -</p> <p style="text-align: center;">Connection to the negative side of the power supply is only required when an external 15 V power supply is used.</p>

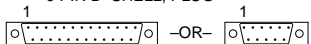
Table 7.8 – Wiring Signal and Control I/O to the Terminal Strip (Continued)

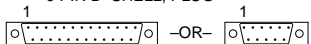
Terminal Number	Description	Parameters/Wiring Connections
Wiring Analog Speed Reference Inputs		
12	Isolated Reference Voltage (+10 VDC)	<p>Related parameters:</p> <p>P.000: Control Source P.009: Terminal Strip Analog Input Offset P.010: Terminal Strip Analog Input Gain P.011: Terminal Strip Analog Input Configure</p> <p>Refer to the GV3000/SE Software Start-Up and Reference manual for additional parameter information.</p> <p>Jumper J4 must also be set. See figure 2.6.</p>
13	Analog Speed/Torque Reference Input Voltage (+/- 10 VDC)	
14	Analog Speed/Torque Reference Input Current (0-20 mA)	
15	Isolated Speed/Torque Reference Common (Voltage/Current)	
		 <p style="text-align: center;">INPUT SPEED REFERENCE</p>

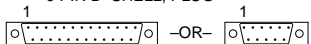
Table 7.8 – Wiring Signal and Control I/O to the Terminal Strip (Continued)

Terminal Number	Description	Parameters/Wiring Connections
Wiring a Remote/Local Input		
16	+24 VDC Power Supply	Current limited for remote input logic use only.
17	Digital Input 8 (Default - Remote/Local)	Digital input 8 is control function programmable through parameter P.007.
	ATTENTION: If a maintained start contact is used when the control source = rE, switching from local to remote from the terminal strip will cause power to be applied to the motor if the remote start contact is closed. Stay clear of rotating machinery in this case. Failure to observe this precaution could result in bodily injury.	
		<p>The following parameters must be set:</p> <ul style="list-style-type: none"> P.000: Control Source (Only active when P.000 = rE) P.006: Second Menu Password P.007: Terminal Strip Digital Inputs Configure (Selects and assigns a control function to digital inputs 6 to 8). P.008: Terminal Strip Speed Reference Source (Analog, Motor Operated Potentiometer (MOP), or Preset Speeds) <p>Note that based on the settings of parameters P.000, P.007, P.008, and r.030 if an RMI board is used, the following parameters can affect digital input 8.</p> <ul style="list-style-type: none"> P.023: MOP Accel/Decel Time P.024: MOP Reset Configuration P.031 to P.038: Preset Speeds 1-8 <p>Refer to the GV3000/SE Software Start-Up and Reference manual for additional information.</p> <div data-bbox="690 1150 1075 1354" style="border: 1px solid black; padding: 10px; margin: 10px auto; width: fit-content;">  </div> <p>Terminal 17 On = Local Control Diagram shows factory setting.</p>

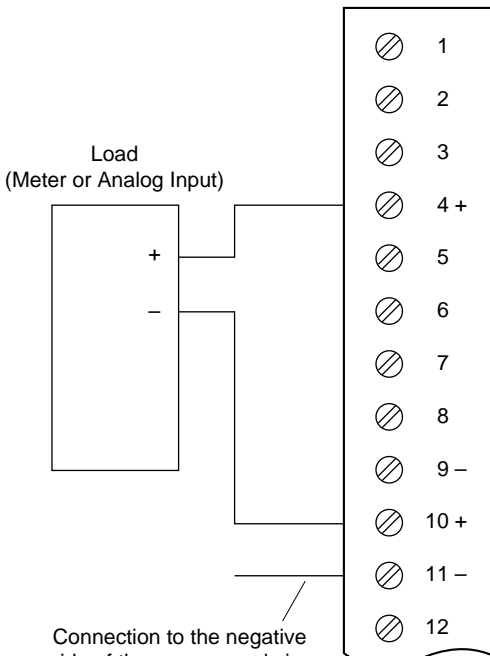
Table 7.8 – Wiring Signal and Control I/O to the Terminal Strip (Continued)

Terminal Number	Description	Parameters/Wiring Connections
Wiring an Additional Ramp Input		
18	Digital Input 7 (Default - Ramp 1/Ramp 2)	<p>Digital input 7 is control function programmable through parameter P.007. The following parameters must be set:</p> <ul style="list-style-type: none"> P.000: Control Source P.001: Accel Time 1 (Ramp 1) P.002: Decel Time 1 (Ramp 1) P.006: Second Menu Password P.007: Terminal Strip Digital Inputs Configure (Selects and assigns a control function to digital inputs 6 to 8). P.008: Terminal Strip Speed Reference Source (Analog, Motor Operated Potentiometer (MOP), or Preset Speeds) P.017: Accel Time 2 (Ramp 2) P.018: Decel Time 2 (Ramp 2) <p>Note that based on the settings of parameters P.000, P.007, P.008, and r.030 if an RMI board is used, the following parameters can affect digital input 7.</p> <ul style="list-style-type: none"> P.023: MOP Accel/Decel Time P.024: MOP Reset Configuration P.031 to P.038: Preset Speeds 1-8 <p>Refer to the GV3000/SE Software Start-Up and Reference manual for additional information.</p> <div data-bbox="837 989 1222 1192" style="text-align: center; border: 1px solid black; padding: 5px;"> </div> <p>Terminal 18 On = Ramp 2 Diagram shows factory setting.</p>

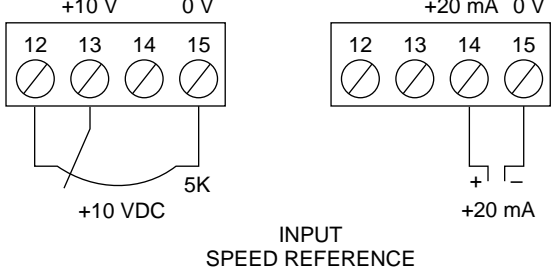
Table 7.8 – Wiring Signal and Control I/O to the Terminal Strip (Continued)

Terminal Number	Description	Parameters/Wiring Connections
Wiring a Forward/Reverse Input		
19	Digital Input 6 (Default - Forward/Reverse)	<p>Digital input 6 is control function programmable through parameter P.007. The following parameters must be set:</p> <ul style="list-style-type: none"> P.000: Control Source P.006: Second Menu Password P.007: Terminal Strip Digital Inputs Configure (Selects and assigns a control function to digital inputs 6 to 8). P.008: Terminal Strip Speed Reference Source (Analog, Motor Operated Potentiometer (MOP), or Preset Speeds) P.027: Forward/Reverse Configuration <p>Note that based on the settings of parameters P.000, P.007, P.008, and r.030 if an RMI board is used, the following parameters can affect digital input 6.</p> <ul style="list-style-type: none"> P.023: MOP Accel/Decel Time P.024: MOP Preset Configuration P.031 to P.038: Preset Speeds 1-8 <p>Refer to the GV3000/SE Software Start-Up and Reference manual for additional information.</p> <div data-bbox="735 905 1118 1108" style="border: 1px solid black; padding: 5px; margin: 10px auto; width: fit-content;"> <p style="text-align: center; font-size: small;">IF P.027 = 1, FORWARD DIRECTION ONLY</p> </div> <p>Terminal 19 On = Reverse Direction Diagram shows factory setting. From the encoder end of the motor, clockwise rotation indicates forward motor movement.</p>

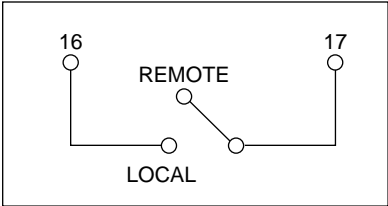
Table 7.8 – Wiring Signal and Control I/O to the Terminal Strip (Continued)

Terminal Number	Description	Parameters/Wiring Connections
Wiring a Function Loss Input		
20	Digital Input 5 (Function Loss)	<p>The following parameters must be set:</p> <p>P.026: Function Loss Response</p> <p>A signal must be present at terminal 20 for the drive to be able to start. See figures 7.1 and 7.2 The drive is shipped from the factory with a jumper between terminals 16 and 20 which provides the signal. The function loss input should be in series with the drive's external interlocks. In this case, the jumper must be removed before the connections are made. See figure 2.8.</p> <div data-bbox="873 617 1399 898" style="border: 1px solid black; padding: 10px; text-align: center;"> <p>TERMINAL STRIP</p> <p>REMOVE FACTORY FUNCTION LOSS JUMPER HERE.</p> <p>FUNCTION LOSS COAST-STOP PUSH-BUTTON</p> <p>SAFETY INTERLOCKS</p> </div> <p>Terminal 20 On = No Function Loss</p> <p>IMPORTANT: A maintained function loss switch should be used if P.054 (Level Sense Start Enable) = ON and P.026 = 1.</p>
Wiring a Run/Jog Input		
21	Digital Input 4 (Run/Jog)	<p>The following parameters must be set:</p> <p>P.000: Control Source</p> <p>P.020: Jog Speed Reference</p> <p>P.021: Jog Ramp Accel Time</p> <p>P.022: Jog Ramp Decel Time</p> <div data-bbox="906 1264 1292 1470" style="border: 1px solid black; padding: 10px; text-align: center;"> </div> <p>Terminal 21 On = Jog Operation</p>

Table 7.8 – Wiring Signal and Control I/O to the Terminal Strip (Continued)

Terminal Number	Description	Parameters/Wiring Connections
Wiring the Reset Input		
22	Digital Input 3 (Reset)	<p>The following parameter must be set:</p> <p>P.000: Control Source</p>  <p>Terminal 22 On = Reset</p>
Wiring the Stop/Start Inputs		
23	Digital Input 2 (Stop)	<p>The following parameters must be set:</p> <p>P.000: Control Source</p> <p>P.025: Stop Type</p>  <p>Terminal 23 Off = Stop Terminal 24 On Transition = Start</p>
25	24 VDC Isolated Common	
Wiring the Snubber Resistor		
26	Snubber Resistor Braking Control Signal	<p>Used with older Snubber Resistor Braking Kits that require a gate turn-on signal from the drive (for example, the M/N 2DB4020 series).</p> <p>Note that terminals 26 and 27 are not to be used with Snubber Resistor Braking Kits M/N 2SR40400, 2SR40600, 2SR41200, 2SR41800, and 2SR40700.</p>
27	+24 VDC Isolated Common	

Table 7.8 – Wiring Signal and Control I/O to the Terminal Strip (Continued)

Terminal Number	Description	Parameters/Wiring Connections
Wiring the Output Status Relays		
28	Normally-Closed Contact (Form B)	Both Form A and Form B contacts are rated for 250 VAC/30 VDC at 5 amps resistive or 2 amps inductive load.
29	Normally-Closed Contact Common (Form B)	The following parameter must be set: P.013: Output Relay Configuration
30	Normally-Open Contact (Form A)	Note that depending on the setting of parameter P.013, the relay coil will energize (the normally-open contact will close and the normally-closed contact will open). Refer to the GV3000/SE Software Start-Up and Reference manual for more information.
31	Normally-Open Contact Common (Form A)	
 <p>PARAMETER P.013 SELECTS OUTPUT INDICATION</p>		

Completing the Installation

This chapter provides instructions on how to perform a final check of the installation before power is applied to the drive.

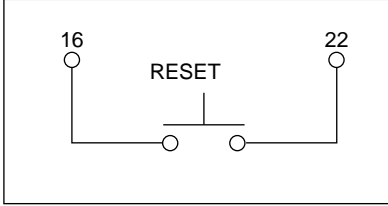
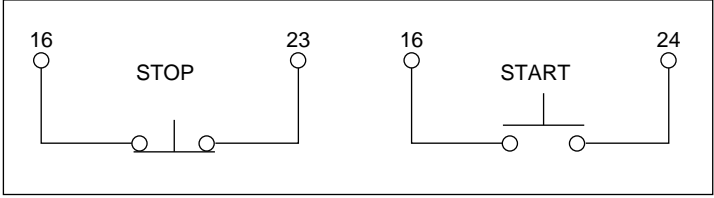
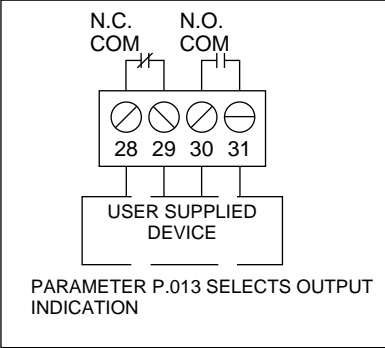

ATTENTION: Only qualified electrical personnel familiar with the construction and operation of this equipment and the hazards involved should start and adjust it. Read and understand this manual in its entirety before proceeding. Failure to observe this precaution could result in severe bodily injury or loss of life.

8.1 Checking the Installation

Use the following procedure to verify the condition of the installation:



ATTENTION: DC bus capacitors retain hazardous voltages after input power has been disconnected. After disconnecting input power, wait five (5) minutes for the DC bus capacitors to discharge and then check the voltage with a voltmeter to ensure the DC bus capacitors are discharged before touching any internal components. Failure to observe this precaution could result in severe bodily injury or loss of life.

- Step 1. Turn off, lock out, and tag the input power to the drive. Wait five minutes.
- Step 2. Verify that the DC bus voltage is zero. Refer to section 9.3.
- Step 3. If a function loss coast-stop push-button has been installed, verify that it has been wired correctly. Be sure the factory-installed jumper at terminals 16 and 20 has been removed so that the coast-stop push-button will work.



ATTENTION: The user must provide an external, hardwired emergency stop circuit outside of the drive circuitry. This circuit must disable the system in case of improper operation. Uncontrolled operation may result if this procedure is not followed. Failure to observe this precaution could result in bodily injury.

- Step 4. Remove any debris, such as metal shavings, from around the drive.
- Step 5. Check that there is adequate clearance around the drive.
- Step 6. Verify that the wiring to the terminal strip and the power terminals is correct.
- Step 7. Check that the wire size is within terminal specification and that the wires are tightened properly.

- Step 8. Check that user-supplied branch circuit protection is installed and correctly rated.
- Step 9. Check that the incoming power is rated correctly.
- Step 10. Check the motor installation and length of motor leads.
- Step 11. Disconnect any power correction capacitors connected between the drive and the motor.
- Step 12. Check that the rating of the transformer (if used) matches the drive requirements and is connected properly.
- Step 13. Verify that a properly-sized ground wire is installed and a suitable earth ground is used. Check for and eliminate any grounds between the motor frame and the motor power leads. Verify that all ground leads are unbroken.
- Step 14. Uncouple the motor from any driven machinery to initially start the drive.

8.2 Powering Up After Installation is Complete

Use the following procedure to verify that the drive is installed correctly and is receiving the proper line voltage:

- Step 1. Turn the drive's input power disconnect to the On position.
- Step 2. Apply power to the drive.
- Step 3. Follow the start-up procedure in the GV3000/SE Software Start-Up and Reference manual.

Troubleshooting the Drive

This chapter describes how to troubleshoot the drive and the equipment that is needed to do so. Also provided are replacement part lists and information on clearing faults.

9.1 Test Equipment Needed to Troubleshoot

An isolated multimeter will be needed to measure DC bus voltage and to make resistance checks. Note that dedicated troubleshooting test points are not provided.

9.2 Drive Alarms and Faults

The drive will display alarm and fault codes to assist in troubleshooting when a problem develops during self-tuning or drive operation.

If an alarm condition occurs, the drive will continue to run and a 2- or 3-digit alarm code will flash on the display.

If a fault occurs, the drive will coast-to-rest stop and a 2- or 3-digit fault code will flash on the display.

Refer to the GV3000/SE Software Start-up and Reference manual for more information on drive alarms and faults.

9.3 Verifying That DC Bus Capacitors are Discharged



ATTENTION: DC bus capacitors retain hazardous voltages after input power has been disconnected. After disconnecting input power, wait five (5) minutes for the DC bus capacitors to discharge and then check the voltage with a voltmeter to ensure the DC bus capacitors are discharged before touching any internal components. Failure to observe this precaution could result in severe bodily injury or loss of life.

The GV3000/SE drive's DC bus capacitors retain hazardous voltage after input power has been disconnected. Perform the following steps before touching any internal components:

- Step 1. Turn off and lock out AC input power. Wait five minutes.
- Step 2. Remove the drive's cover.

- Step 3. Verify that there is no voltage at the drive's input power terminals.
- Step 4. Measure the DC bus potential with a voltmeter at the DC bus power terminals while standing on a non-conductive surface and wearing insulated gloves (600 V). See figure 9.1.
- Step 5. Once the drive has been serviced, reattach the drive's cover.
- Step 6. Reapply AC input power.

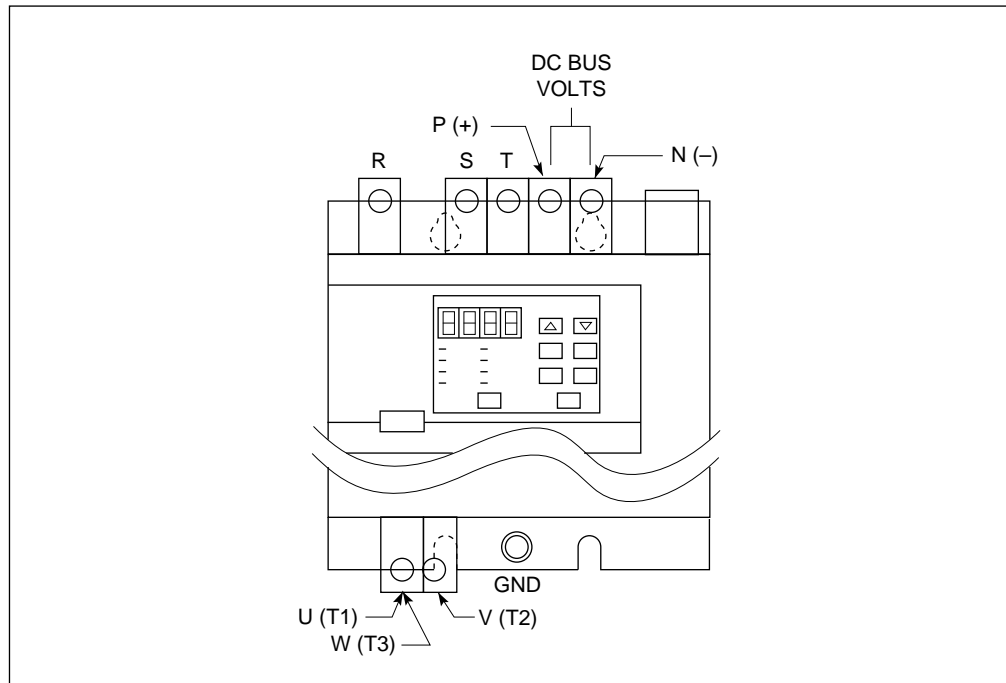

Figure 9.1 – DC Bus Voltage Terminals

9.4 Checking Out the Power Module with Input Power Off

Use the following procedure to check the drive's Power Module circuitry with power off:



ATTENTION: DC bus capacitors retain hazardous voltages after input power has been disconnected. After disconnecting input power, wait five (5) minutes for the DC bus capacitors to discharge and then check the voltage with a voltmeter to ensure the DC bus capacitors are discharged before touching any internal components. Failure to observe this precaution could result in severe bodily injury or loss of life.

- Step 1. Turn off and lock out input power. Wait five minutes.
- Step 2. Remove the drive's cover.
- Step 3. Verify that there is no voltage at the drive's input terminals.

Step 4. Check the DC bus potential with a voltmeter as described in section 9.3 to ensure that the DC bus capacitors are discharged.

Step 5. Disconnect the motor from the drive.

Step 6. Check all AC line and DC bus fuses.

Step 7. If a fuse is open, use a multimeter to check the input diodes and output IGBTs. See table 9.1.

Note that the drives do not have replaceable transistor modules: the entire drive must be replaced if a transistor malfunctions.

Step 8. Reconnect the motor to the drive.

Step 9. Reattach the drive's cover.

Step 10. Reapply input power.

Table 9.1 – Resistance Checks

Input Diode No.	Meter Connection		Component is OK if resistance (R) is:	Component is defective if:
	(+)	(-)		
1	*	R/L1	50 kΩ < R < 10 MΩ	Continuity (short circuit) or open when the meter is connected with reversed polarity
2	*	S/L2		
3	*	T/L3		
4	R/L1	**		
5	S/L2	**		
6	T/L3	**		
* (+) DC Bus Volts power terminal ** (-) DC Bus Volts power terminal				

Input Diode No.	Meter Connection		Component is OK if resistance (R) is:	Component is defective if:
	(+)	(-)		
1	*	W/T3	50 kΩ < R < 10 MΩ	Continuity (short circuit) or open when the meter is connected with reversed polarity
2	*	V/T2		
3	*	U/T1		
4	W/T3	**		
5	V/T2	**		
6	U/T1	**		
* (+) DC Bus Volts power terminal ** (-) DC Bus Volts power terminal				

9.5 Replacement Parts

Table 9.2 lists the replacement parts that are available from Reliance Electric. See figures 2.2 to 2.4 for the location of the parts.

Table 9.2 – Replacement Parts for the GV3000/SE Drives

Description	Part Number	Power Module					
		75V4060	100V4060	125V4060	150V4060	200V4060	
Regulator Board	0-56921-XXX	1	1	1	1	1	
Base Board ⁽¹⁾	PISC-75	827707	1	1	1	–	–
	PISC-75A	827710	(1)	(1)	(1)	1	1
Membrane Switch Keypad/Bracket Assembly	907016	1	1	1	1	1	
Internal Fan Assembly	907017	1	1	1	1	1	
Diode Module Fan Assembly	907018	2	2	2	–	–	
	907019	–	–	–	1	1	
IGBT Module Fan Assembly	907020	2	2	2	2	2	
IGBT Module	536663	3	3	–	–	–	
	534903	–	–	6	–	–	
	534941	–	–	–	6	6	
Diode Bridge	512783	1	1	–	–	–	
	512901	–	–	2	–	–	
	514705	–	–	–	6	6	
DC Bus Fuse	286323	1	1	–	–	–	
	286326	–	–	1	–	–	
	286327	–	–	–	1	1	
DC Bus Capacitor	453136B	8	8	12	16	16	

⁽¹⁾ For 75 HP, 100 HP and 125 HP drives, either Base Board PISC-75 or PISC-75A can be used. But for 150 HP and 200 HP drives, use Base Board PISC-75A only.

APPENDIX A

Technical Specifications

Table A.1 – Service Conditions

AC Line Distribution System Capacity (maximum) for 460 VAC Units	Three-phase with 85,000 amps symmetrical fault current capacity with AC line reactor with a line impedance of less than 5%.
Control Method	All-digital vector, sinusoidal pulse-width-modulated (PWM)
Displacement Power Factor	0.96
Line Frequency	50 ± 5 Hz or 60 ± 5 Hz
Line Voltage Variation	–10% to +10%
Line Dip Ride Through	Maximum 500 milliseconds - FVC Adjustable up to 999.9 seconds (See P.042) - V/Hz, SVC
Motor Lead Lengths	76 meters (250 feet) total
Remote Operator Control Wire Length	Up to 303 meters (1000 feet) from the drive
Analog Speed Reference Resolution	1/1024 (10 bits) 0.1%
Acceleration Adjustment Range	0.1 to 999.9 seconds (within the ability of current)
Carrier Frequency	2 kHz, 4 kHz, or 8 kHz, software-selectable
Current Limit Adjustment	U.006 to 150% (based on motor nameplate rating) - vector 50 to 100% (based on motor nameplate rating) - V/Hz ⁽¹⁾
Service Factor	1.0
Speed Adjustable Range	From 0 RPM to maximum speed (vector)
Speed Regulation	Vector - 0.01% FVC, 0.5% SVC (steady-state) V/Hz - motor slip-dependent
Speed Setpoint Resolution	1 RPM with local keypad, –4095 to +4095 counts with a network or serial reference
Torque Control Response	180 to 220 Hz
Torque Linearity	±3% with optimal parameter setting (typical) (see parameter U.005)

⁽¹⁾ For V/Hz regulation, the overload current is limited to 100% of the drive nameplate rating.
(For vector regulation, the overload current is limited to 150% of the drive nameplate rating.)

Table A.2 – Environmental Condition

Condition	Specification
Operating Temperature (Ambient)	0° to 40°C (32° to 104°F)
Storage Temperature (Ambient)	–40° to 65°C (–40° to 149°F)
Humidity	5 to 95% non-condensing

Table A.3 – Terminal Strip Input Specifications

Signal Type	Terminal(s)	Specification
Speed Reference Input	12-15	5 KW potentiometer (0 to +/- 10 VDC @ 50 K Ω input impedance) or 0-20 mA (@250 Ω input impedance) with 10-bit resolution. (Jumper-selectable by jumper J4; refer to section 2.4.1.) Note that the drive provides +15 VDC buffered through a 1.875 K Ω resistor.
Digital Inputs (1 - 8)	16	+24 VDC Isolated Supply
	17	Remote/Local (Default)
	18	Ramp1/Ramp2 (Default)
	19	Forward/Reverse (Default)
	20	Function Loss
	21	Run/Jog
	22	Reset
	23	Stop
	24	Start

Table A.4 - Terminal Strip Output Specifications

Signal Type	Terminal(s)	Specification
Analog Output	10 - 11 scaled signal	0-10 VDC or 4-20 mA
Snubber Resistor	26-27	Used with older Snubber Resistor Braking Kits such as M/N 2DB4010 series that requires a gate turn-on signal from the drive.

Table A.5 – Terminal Strip RS-232 Specifications

Signal Type	Terminal(s)	Specification
RS-232 Communications	1	XMIT
	2	RECV
	3	COMMON

Table A.6 – Encoder Feedback Device Specifications (FVC Regulation Only)

Specification	Rating
Motor Poles	2, 4, 6, or 8 poles
Overcurrent IET	200% load (based on drive nameplate rating)
Overload Current Rating	150% for 1 minute (based on drive nameplate rating)
Speed Control Range	1:600 with 1024 PPR
Speed Control Response	15 Hz (typical)
Encoder Feedback	15 V differential quadrature, encoder incremental (512 PPR, 1024 PPR, 2048 PPR, 4096 PPR)
Service Factor	1.0

Table A.7 – Input Signal Response Times (Maximum)

Signal Type and Source	Volts/Hertz Regulation ⁽¹⁾	Vector Regulation ⁽¹⁾
Keypad START	150 milliseconds	130 milliseconds
Terminal Strip:		
START	126 milliseconds	105 milliseconds
STOP, RESET, FL	75 milliseconds	75 milliseconds
Preset Speeds	75 milliseconds	75 milliseconds
Analog Speed/Trim Reference	16 milliseconds	5 milliseconds
Analog Torque Reference	N/A	0.5 milliseconds
Network:		
START	46 milliseconds + network transport time	25 milliseconds + network transport time
STOP, RESET, FL	26 milliseconds + network transport time	25 milliseconds + network transport time
Analog Speed/Trim Reference	5 milliseconds + network transport time	5 milliseconds + network transport time
	N/A	0.5 milliseconds + network transport time

⁽¹⁾ These are the maximum times from transitioning the input to the drive reacting to the input.

75-200 HP GV3000/SE System Wiring Diagram

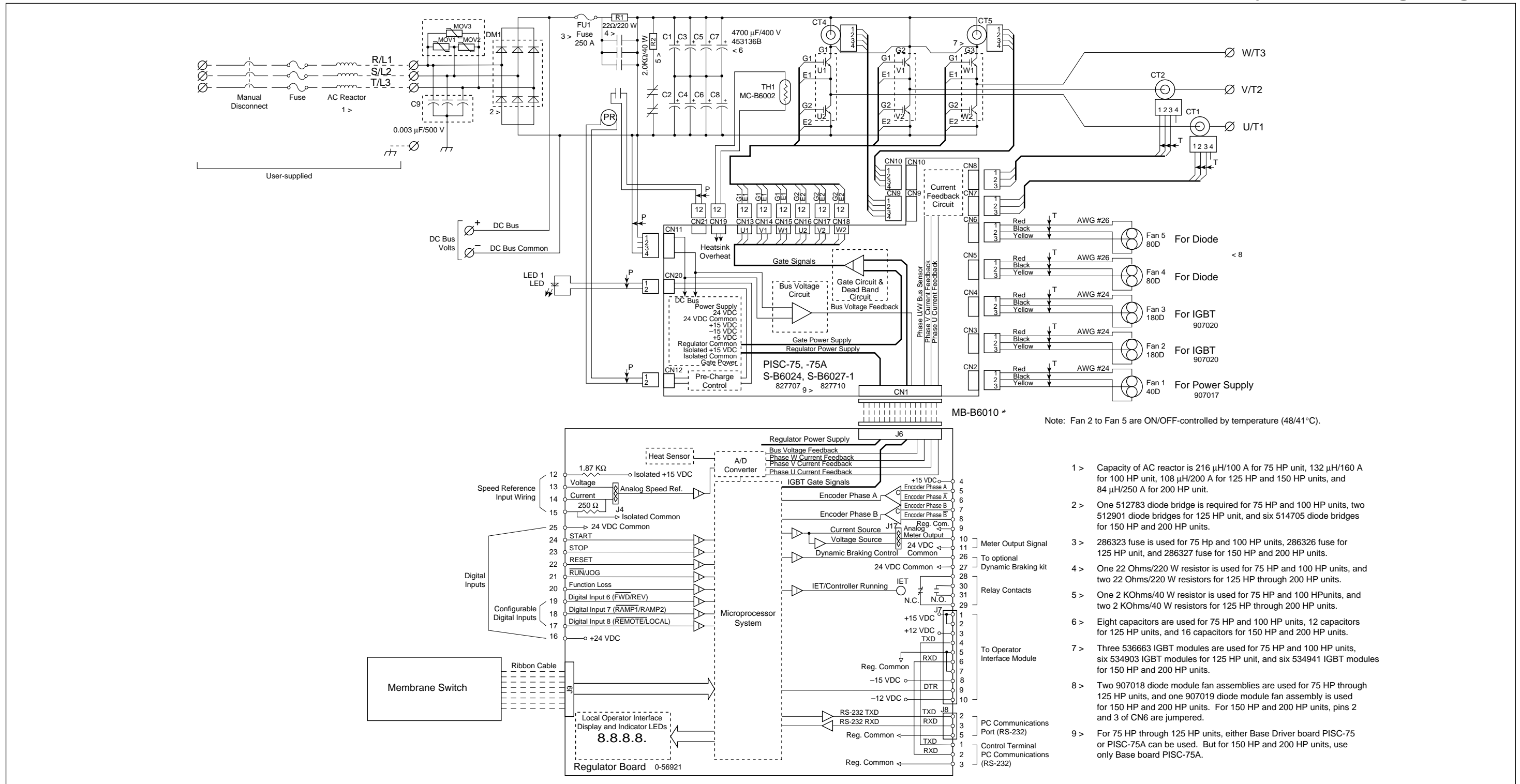

- 1 > Capacity of AC reactor is 216 μH/100 A for 75 HP unit, 132 μH/160 A for 100 HP unit, 108 μH/200 A for 125 HP and 150 HP units, and 84 μH/250 A for 200 HP unit.
- 2 > One 512783 diode bridge is required for 75 HP and 100 HP units, two 512901 diode bridges for 125 HP unit, and six 514705 diode bridges for 150 HP and 200 HP units.
- 3 > 286323 fuse is used for 75 Hp and 100 HP units, 286326 fuse for 125 HP unit, and 286327 fuse for 150 HP and 200 HP units.
- 4 > One 22 Ohms/220 W resistor is used for 75 HP and 100 HP units, and two 22 Ohms/220 W resistors for 125 HP through 200 HP units.
- 5 > One 2 KOhms/40 W resistor is used for 75 HP and 100 HP units, and two 2 KOhms/40 W resistors for 125 HP through 200 HP units.
- 6 > Eight capacitors are used for 75 HP and 100 HP units, 12 capacitors for 125 HP units, and 16 capacitors for 150 HP and 200 HP units.
- 7 > Three 536663 IGBT modules are used for 75 HP and 100 HP units, six 534903 IGBT modules for 125 HP unit, and six 534941 IGBT modules for 150 HP and 200 HP units.
- 8 > Two 907018 diode module fan assemblies are used for 75 HP through 125 HP units, and one 907019 diode module fan assembly is used for 150 HP and 200 HP units. For 150 HP and 200 HP units, pins 2 and 3 of CN6 are jumpered.
- 9 > For 75 HP through 125 HP units, either Base Driver board PISC-75 or PISC-75A can be used. But for 150 HP and 200 HP units, use only Base board PISC-75A.

Reach us now at www.rockwellautomation.com

Wherever you need us, Rockwell Automation brings together leading brands in industrial automation including Allen-Bradley controls, Reliance Electric power transmission products, Dodge mechanical power transmission components, and Rockwell Software. Rockwell Automation's unique, flexible approach to helping customers achieve a competitive advantage is supported by thousands of authorized partners, distributors and system integrators around the world.



Americas Headquarters, 1201 South Second Street, Milwaukee, WI 53204, USA, Tel: (1) 414 382-2000, Fax: (1) 414 382-4444
European Headquarters SA/NV, avenue Herrmann Debroux, 46, 1160 Brussels, Belgium, Tel: (32) 2 663 06 00, Fax: (32) 2 663 06 40
Asia Pacific Headquarters, 27/F Citicorp Centre, 18 Whitfield Road, Causeway Bay, Hong Kong, Tel: (852) 2887 4788, Fax: (852) 2508 1846

**Rockwell
Automation**