

# Fuji Inverter FVR-E7S-AX

**200 V 3 $\Phi$  Series, 0.1 to 3.7 kW (1/8 to 5HP)**

**200 V 1 $\Phi$  Series, 0.1 to 2.2 kW (1/8 to 3HP)**

**400 V 3 $\Phi$  Series, 0.4 to 3.7 kW (1/2 to 5HP)**

## Instruction Manual

### Contents

- 
- |   |      |   |
|---|------|---|
| 1. Warning and Caution .....                    | p.1  | (3) Selecting Operation Method                  |
| 2. Introduction .....                           | p.2  | (4) Setting Data Codes                          |
| 3. Inspection Upon Receipt .....                | p.2  | (5) Control Circuit Connection<br>And Operation |
| 4. Construction And Handling .....              | p.3  | (6) Actual Operation                            |
| (1) Part Name                                   |      |   |
| (2) Installation And Removing<br>Terminal Cover |      | 9. Function Explanation .....                   |
| 5. Installation Instructions .....              | p.4  | (1) Function Code Tables                        |
| (1) Installation Conditions                     |      | (2) Function Explanation                        |
| (2) Mounting Direction And Space                |      | 10. Maintenance And Inspection .....            |
| (3) Mounting Screws And Holes                   |      | (1) Inspection Items                            |
| (4) Removing the ventilation covers             |      | (2) Periodic Replacement Part                   |
| 6. Wiring .....                                 | p.5  | (3) Measurement Points And<br>Meters            |
| (1) Main Circuit Wiring                         |      | 11. Troubleshooting .....                       |
| (2) Control Circuit Wiring                      |      | (1) Protective Function                         |
| (3) Basic Wiring Diagram                        |      | (2) Troubleshooting                             |
| 7. Keypad Panel .....                           | p.8  | 12. Appendix .....                              |
| (1) Part Name And Function                      |      | (1) Standard Specifications                     |
| (2) Controlling Method of Keypad<br>Panel       |      | (2) External Dimensions                         |
| (3) Display And Key Operation                   |      | (3) Application of Wiring And<br>Equipment      |
| 8. Operation .....                              | p.16 | (4) Terminal Function                           |
| (1) Pre-Operation Inspection                    |      | (5) Control Block Diagram                       |
| (2) Test Run Check Points                       |      |   |
-

# 1. Warning and Caution

Mis-Wiring will result in damage to, and failure of the unit.

Please carefully note the items listed below, and use the unit as indicated.

## Warning

- ① Hazard of electrical shock, disconnect incoming power before working on this control. Dangerous voltage exist until CRG-LED is off. Maintenance and Inspection should be performed only after CRG-LED has gone out.
- ② Do not impress power supply voltage that exceeds the standard specification voltage permissible fluctuation. If excessive voltage is applied to the inverter, damage to the internal elements will result.
- ③ Do not connect power supply to the output terminal (U, V, W). Connect power supply only to the power terminals (2AX, 4AX:L1, L2, L3 7AX:L1, L2).
- ④ Do not connect power supply to the breaking resistor connection terminals (P (+), DB). Never shortcircuit between P (+) – DB terminals, and do not connect any resistance with an ohm and/or wattage value less than standard application breaking resistor.
- ⑤ Do not connect power supply to the control circuit terminals (except 30A, 30B, 30C).
- ⑥ For RUN and STOP, use the FWD-CM (forward) and REV-CM (reverse) terminals. Avoid using a magnetic contactor (ON/OFF) installed on the line side of the inverter for RUN and STOP.
- ⑦ Do not use a magnetic contactor on the output side of the inverter for ON/OFF operation.
- ⑧ Use only power capacity within the inverter capacity range of 1.5 times to 500 kVA. If a power capacity greater than 500 kVA is to be used, install a coordination reactor (ACR...option) on the line side of the inverter.
- ⑨ Do not connect a power factor correcting capacitor to the output side of the inverter.
- ⑩ Do not operate without the ground wire connected.
- ⑪ If the inverter protective function is activated, consult Section 11 "Troubleshooting", and after correcting the problem, resume operation. Do not reset the alarm automatically by external sequence, etc.
- ⑫ Do not perform a megger test between the inverter terminals or on the control circuit terminals.
- ⑬ RUN and STOP keys function only keypad operation mode. (Function code F 02 setting is 0).

## Caution

- ① When terminal operation mode (Function code F 02 setting is 1) – RUN and STOP being controlled by a maintained contact (e.g., selector switch, toggle switch, etc.) which is connected between the terminals CM and FWD or REV – is employed:
  - Closing/opening the maintained contact starts/stops the inverter – driven motor with power supply impressed.
  - Power up and down starts and stops the inverter – driven motor, respectively, with the maintained contact closed, and
  - Resetting fault starts the inverter driven motor with power supply impressed, and the maintained contact closed.
- ② Function code F 02 setting can be changed only when connection between the terminals CM and FWD or REV is open. (i.e. STOP MODE)
- ③ When "Restart after momentary power failure" is disabled – function code F 14 setting is 0, with the terminals CM-FWD or REV closed – resetting the inverter after power supply has been recovered will start the inverter-driven motor.
- ④ Total wiring between the inverter and the motor must not exceed the length shown below.

Function F 12 data	200 V series						400 V series						
	001	002	004	008	015	022	037	004	008	015	022	037	
F 12=0, 1, 2 or 3	100 m						50 m	70 m	100 m				
F 12=4 or 5							20 m						

- ⑤ Error in current detection may become large when;
  - a) A specially designed motor is used.
  - b) An inverter capacity is 2 ranks or more larger than a motor capacity.

## 2. Introduction

Thank you for purchasing the Fuji "FVR-E7S" inverter. This inverter uses a 32-bit DSP for multi-function and high performance in a variety of applications.

This instruction manual is included with the inverter and equipment, and is provided for the convenience of the end user. Please be sure it accompanies the inverter.

## 3. Inspection Upon Receipt

Please inspect the following items upon receipt of your inverter.

- ① Check the nameplate to insure that the specifications correspond to those ordered.
- ② Inspect the unit for damage which may have occurred during shipping.

If you have any problems or questions regarding the inverter, please contact the nearest Fuji sales office or the distributor where the unit was purchased.

Nameplate

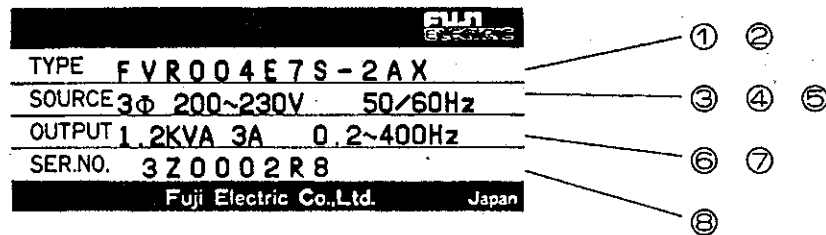

### ① Applicable Motor:

- 001 : 1/8 HP (0.1 kW)
- 002 : 1/4 HP (0.2 kW)
- 004 : 1/2 HP (0.4 kW)
- 008 : 1 HP (0.75 kW)
- 015 : 2 HP (1.5 kW)
- 022 : 3 HP (2.2 kW)
- 037 : 5 HP (3.7 kW)

- ### ② Power Series:
- 2AX : 200 V 3Φ Series
  - 7AX : 200 V 1Φ Series
  - 4AX : 400 V 3Φ Series

- ### ③ Phase : 3Φ = 3 phase
- 1Φ = Single phase

- ### ④ Voltage range
- 200 ~ 230 V : 200 V 3Φ Series
  - 200 V 1Φ Series
  - 380 ~ 460 V : 400 V 3Φ Series

- ### ⑤ Frequency: 50/60 Hz

### ⑥ kVA: Rated capacity

Indicated according to the rated current shown below at an output voltage of 230 V (200 V Series), 460 V (400 V Series).

### ⑦ Rated output current\*

AC 200 V Series	AC 400 V Series
0.8A → 001 (1/8 HP)	1.6A → 004 (1/2 HP)
1.5A → 002 (1/4 HP)	2.5A → 008 (1 HP)
3A → 004 (1/2 HP)	3.7A → 015 (2 HP)
5A → 008 (1 HP)	5.5A → 022 (3 HP)
8A → 015 (2 HP)	9A → 037 (5 HP)
11A → 022 (3 HP)	
17A → 037 (5 HP)	

- ### ⑧ Output frequency range: 0.2 to 400 Hz

- ### ⑨ Serial No.

\* When motor running sound  $F \square \square \square = \square \square \square \square$ ,  $\square \square \square \square$ ,  $\square \square \square \square$  or  $\square \square \square \square$ . Standard values indicated in parentheses.

# 4. Construction And Handling

## (1) Part Names

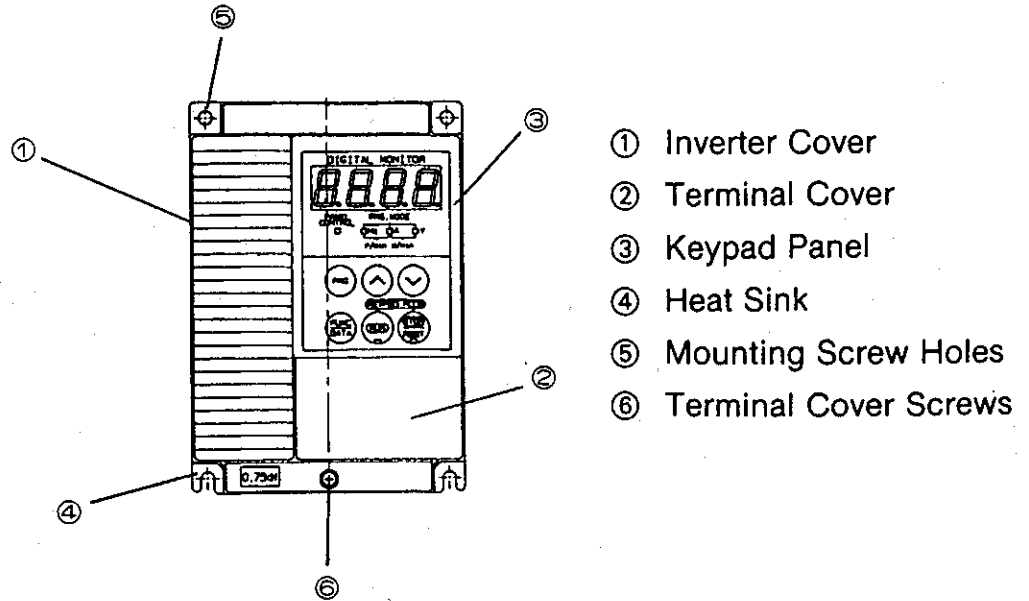

## (2) Installing and Removing Terminal Cover

Remove the terminal cover using the following procedure. Reverse the procedure to install the cover.

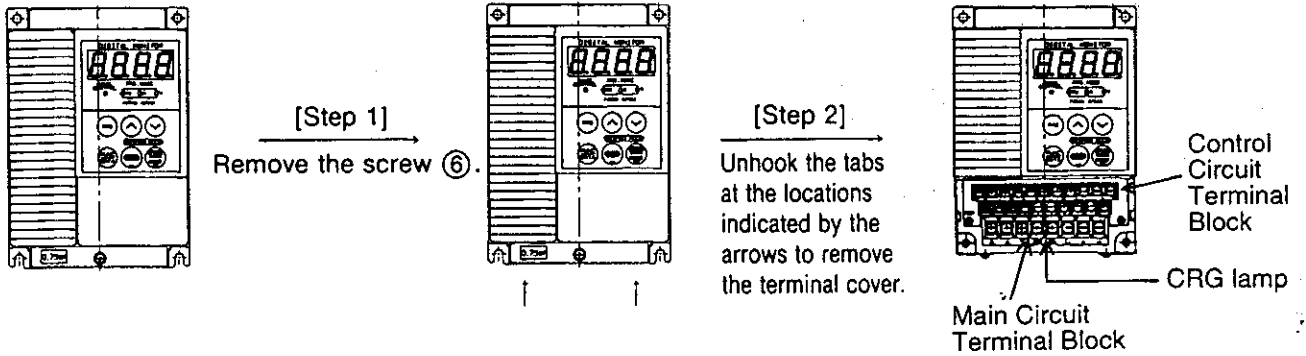

## 5. Installation Instructions

### (1) Installation Conditions

Install the inverter in a location which meets the following requirements.

- ① The ambient temperature should be between  $-10^{\circ}\text{C}$  and  $+50^{\circ}\text{C}$ .
- ② The humidity should be between 20 and 90% RH. Avoid any location subject to dew condensation, freezing or where the inverter would come into contact with any liquids.
- ③ Do not install in any location subject to any of the following conditions: direct sunlight, dust, corrosive gas, inflammable gas or oil mist.
- ④ The inverter should be installed at an elevation below 1000 m, and vibration should be less than  $5.9\text{ m/s}^2$  (0.6 G).

### (2) Mounting Direction and Space

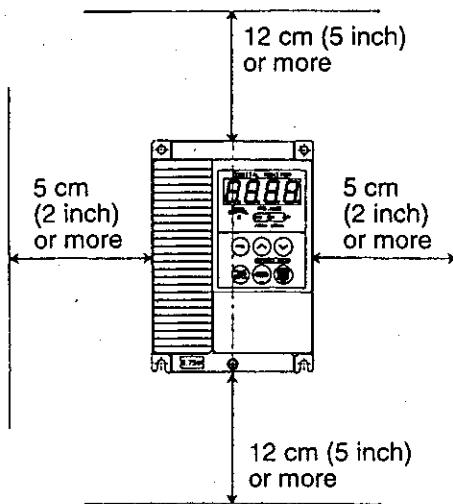

- ① **Direction**  
Install the inverter vertically. Horizontal or other positional installation will cause overheat of the inverter.
- ② **Space**  
The inverter will generate heat during operation. Allow sufficient space around the unit as shown in the figure on the left.
- ③ **Mounting plate**  
Heat sink temperature will reach around  $+90^{\circ}\text{C}$  during operation. Please use thermostable material for inverter mounting plate.
- ④ **Multi-mounting**  
When 2 or more inverters are installed within an inverter switchboard, arrange them side by side, also keeping the spacing (shown on the left) between each inverter. If the inverters must be lined up vertically, provide adequate ventilation so that the hot air from each inverter will not affect the one above it.

### (3) Mounting Screws And Holes

- ① Mounting screws or bolts should be M5
- ② For the location of mounting holes, see "External Dimensions" in Section 12.

#### NOTICE

The durability and reliability of the inverter will be affected by the ambient temperature. Do not place the unit where ambient temperature is not proper.

### (4) Removing the ventilation covers

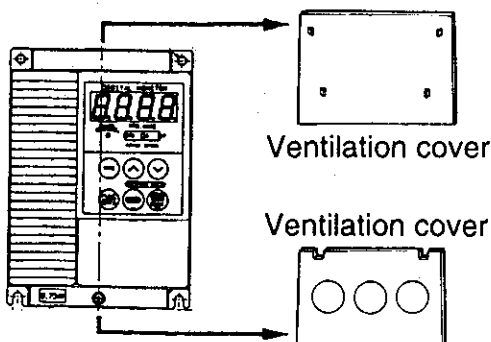

When the temperature around the inverter exceeds  $40^{\circ}\text{C}$ , remove the ventilation cover installed on the top and bottom surfaces of the main body cover before use. When the inverter is used without the ventilation covers, keep the ambient temperature below  $50^{\circ}\text{C}$ .

## 6. Wiring

### (1) Main Circuit Wiring

- ① Power supply connection (2AX, 4AX:L1, L2, L3 7AX:L1, L2): Connection can be made regardless of phase rotation.
- ② Motor wiring (U, V, W): When connected normally, the motor will rotate counter-clockwise when viewed from the load side. If the motor rotates in reverse, either interchange any two of the U, V, W connections or use the control signal REV (reverse-direction operation command) in place of FWD (forward-direction operation command).
- ③ Wiring the External Braking Resistor Unit (option)  
When frequent braking or high torque braking is required, connect the optional braking resistor as shown in the figure at right.

Note:

Models 001E7S and 002E7S are not equipped with terminals P (+) and DB.

200V 3Ø Series, 400V 3Ø Series (2AX, 4AX)

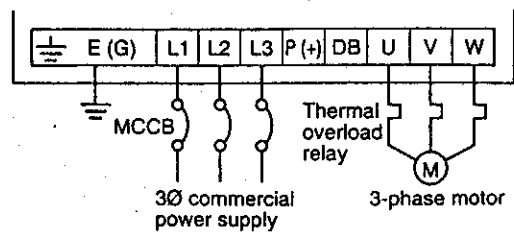

200V 1Ø Series (7AX)

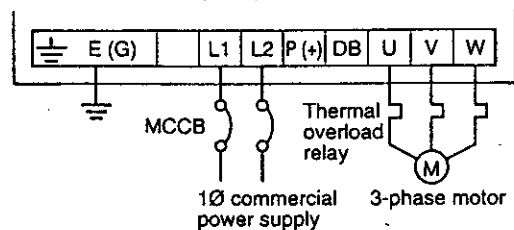

3Ø Series (2AX, 4AX)

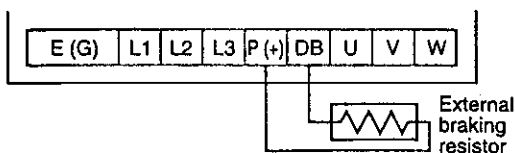

1Ø Series (7AX)

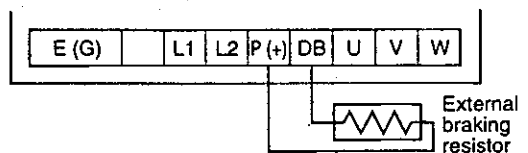

#### Caution:

1. Do not short-circuit terminals P (+) and DB; doing so will damage the inverter.
2. An external braking resistor cannot be connected to Models FVR001E7S-2AX, FVR002E7S-2AX, FVR001E7S-7AX and FVR002E7S-7AX.
3. If the external braking resistor is used frequently, it will become quite hot, therefore route the wiring so that there are no combustible materials near the resistor.
4. Whenever making changes in the wiring or doing any other work, first switch off the power supply and then wait until the charge indication lamp goes out.  
To see the charge indication lamp, remove the terminal cover.

- ④ Ground terminal connection (  $\perp$  E (G) ): For safety reasons, do not operate without the inverter being grounded.  
The ground wire must be as thick and short as possible (See Applicable Wiring Equipment List Section 12 "Appendix").
- ⑤ For model FVR001E7S-2AX and 7AX, if the total wiring length between the inverter and the motor exceeds 50 to 100 m, the indicated current value may be slightly higher than the actual value.
- ⑥ A current value may be indicated when the inverter is operated without the motor wiring being connected to it.

#### Caution:



Do not connect the power supply to terminals U, V, and W or to terminals P (+) and DB.

## (2) Control Circuit Wiring

### ① Factory pre-wiring (jumper) at time of shipment

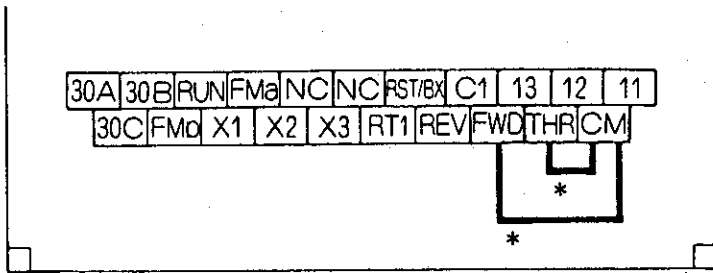
As wired at the factory, starting/stopping and frequency settings can be performed via the keypad panel.



-  : Starts operation
-  : Stops operation
-  : Frequency setting

### ② Operation through control circuit terminals (external operation)

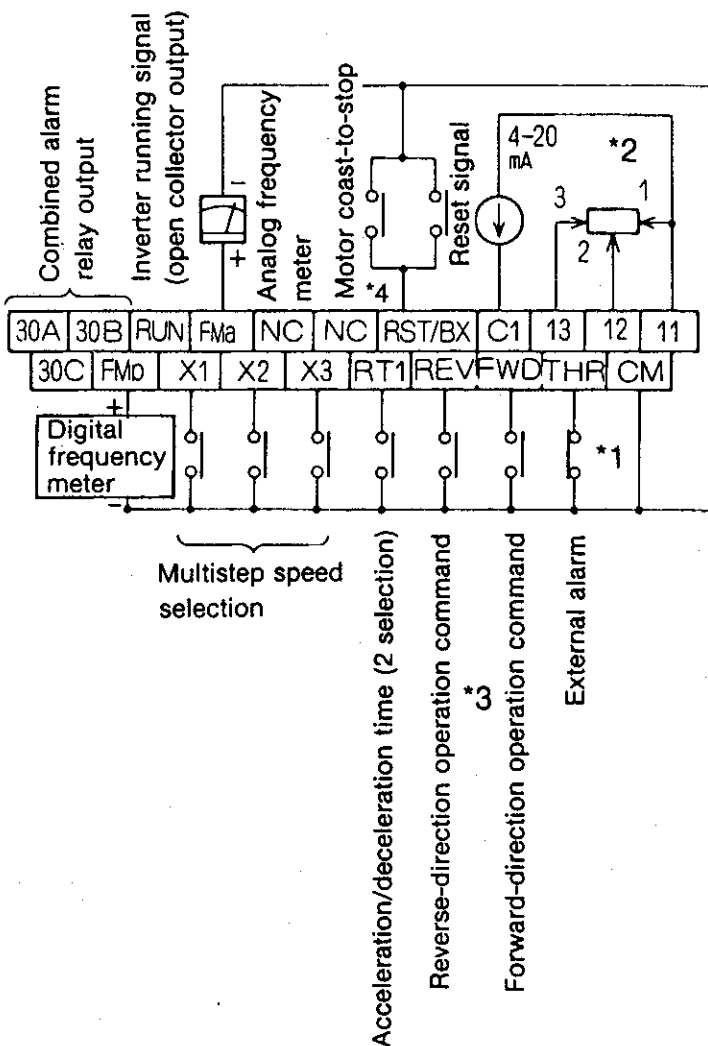

- \*1 Thermal contact (NC) of the external braking resistor, etc.
- \*2 When the current setting and the voltage setting are input at the same time, the setting will be their resultant total value.  
(When the function setting is  $F \square \square i = \square \square \square i$ .)
- \*3 When the FWD and REV signals close at the same time, the inverter will decelerate and stop.
- \*4 Do not connect any wire on NC terminals.

### (3) Basic Wiring Diagram

1Ø 200V Series

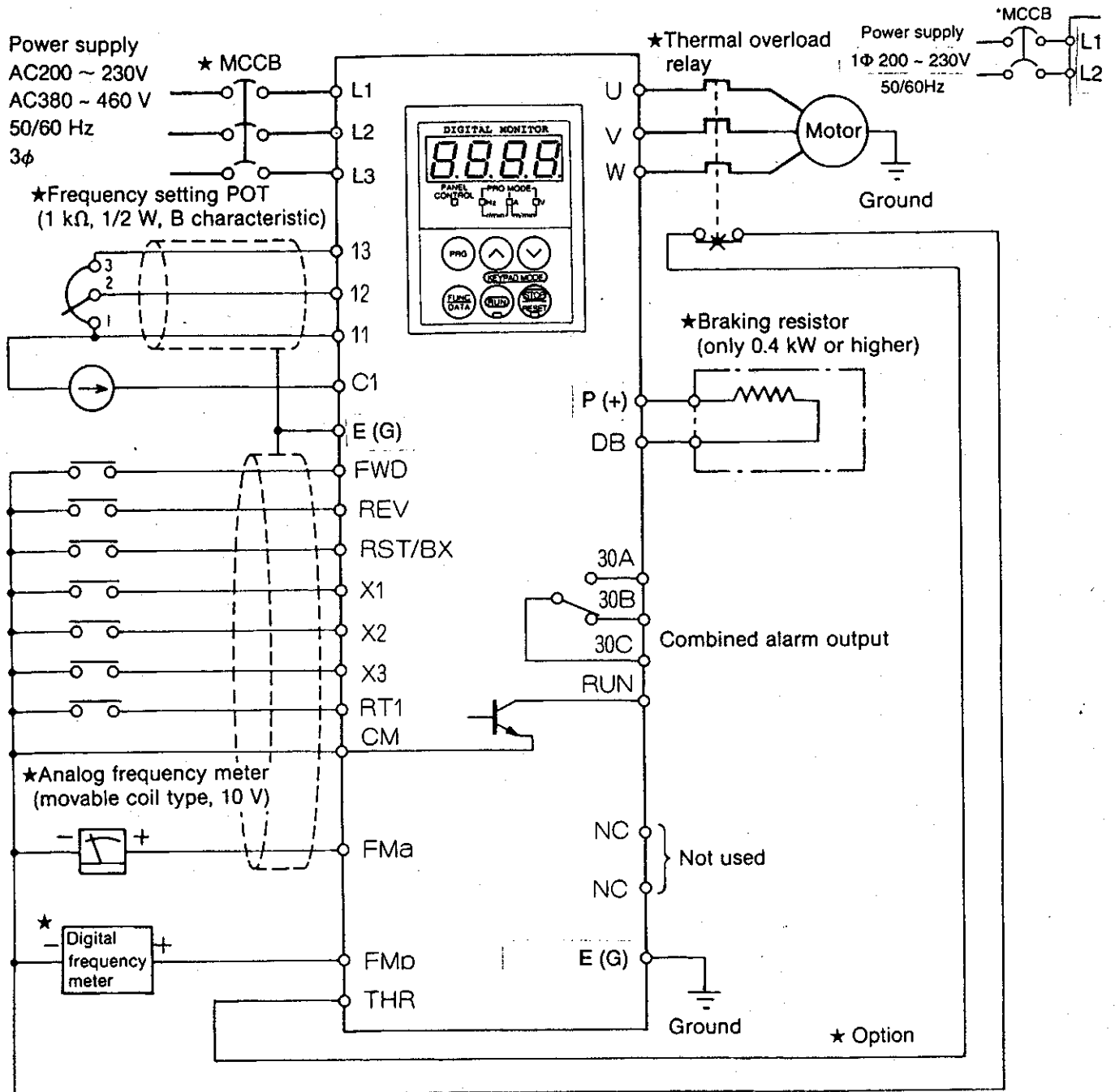

#### [Caution]

- ① The control circuit terminal wiring should be kept as far as possible from the main circuit wiring to prevent operational error due to noise interference. Never install them in the same duct or conduit. (A separation distance of 10 cm or more is recommended.) If the control circuit wiring must cross the main circuit wiring, make sure it crosses at a right angle.
- ② Use shielded wire for the control circuit wiring, which should be as short as possible (20 m or less). (Connect shield to the inverter ground terminal and leave the other end open.)
- ③ Install a surge absorber in parallel with any magnet contactors, solenoids, relays or timer coils, which are close to the inverter.

## 7. Keypad Panel

### (1) Part Names and Functions

#### Digital monitor

Displays the various function codes and data values during setting of the program. During operation, it displays the output frequency, current, voltage, etc. If a fault occurs, the causes of the problem will be displayed as a code.

#### Program (PRG) key

Normal mode or program setting mode select key.

#### Function key (data key)

During the normal mode, this key can be used to change the display unit while operation is either stopped or running.

During the program mode, this key can be used to read and write the function codes and the data.

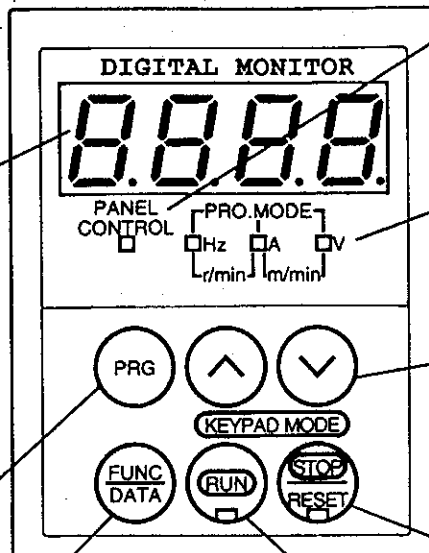

#### RUN key

Key used for starting operation. The LED (green) lights up during operation. This key does not function when terminal operation control  $F02 = 0$  is selected.

#### Operation mode indicator

The LED (green) lights up when keypad panel operation is  $F02 = 0$ .

#### Unit display

Unit information is displayed by LED (red). LEDs also light up to indicate that the unit is in the program mode.

#### UP/DOWN keys

These keys increase or decrease the frequency. When unit is in program setting mode, they change the function code or data values.



#### STOP key (RESET key)

This key is used for stopping operation. While operation is stopped, the LED (red) lights up. The key does not function when terminal operation  $F02 = 0$  is selected. When the protection function is activated, this key is used to reset the fault.

### (2) Controlling Method For Keypad Panel

#### 1) Keypad Panel operation

When the power supply is activated, the keypad panel display will be as shown in the figure on the right.

If the  key is pressed, the inverter will start and accelerate up to 60 Hz according to the factory setting. Use the  key to stop operation.

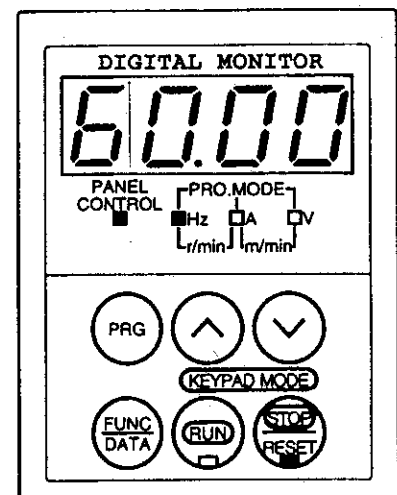

#### WARNING

**RUN AND STOP KEYS FUNCTION ONLY IN KEYPAD OPERATION MODE. (FUNCTION CODE F02 SETTING IS 0)**

## 2) Operation modes

There are 5 operation modes as shown below. The mode can be changed with the keys on the keypad panel.

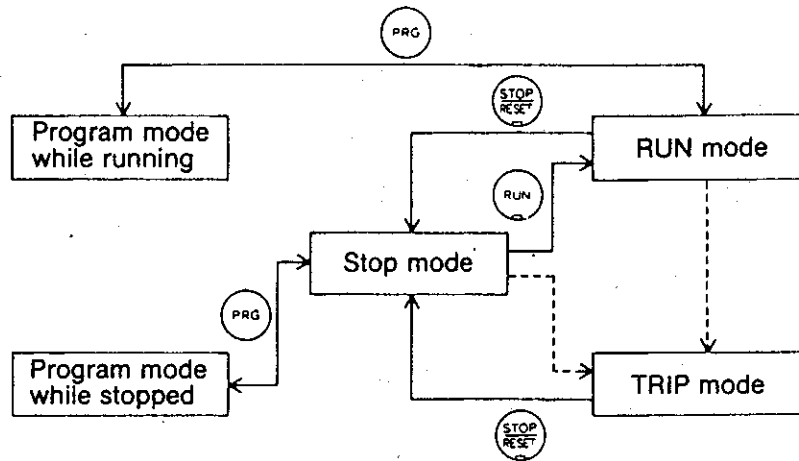

## 3) Data setting

### ① STOP mode

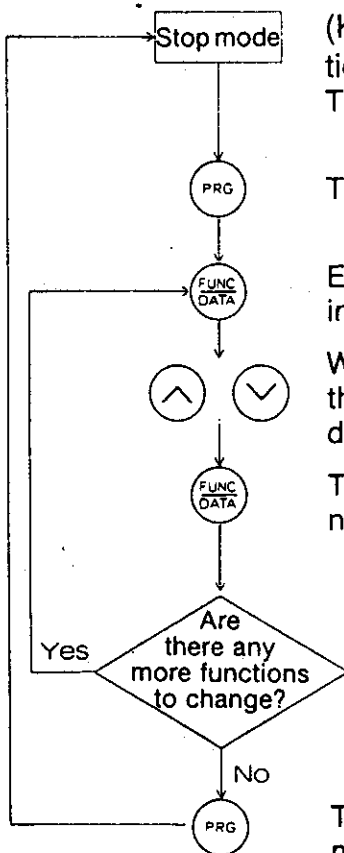

This is the state in which all operation signals (  signal (Keypad operation), FWD and REV signals (Terminal operation)) are OFF.

The reference frequency display flashes repeatedly. 

The mode is switched to function setting mode. 

Each time the key is pressed, the display changes between indication of a function code and its data.







When these keys are pressed while the function code is displayed, the function code No. will change. By pressing them while data is displayed, the data can be changed.

The data is memorized and the function code advances to the next function code No.

For change of other data, repeat the above procedure.

The program mode is ended and the inverter returns to STOP mode.

### ② RUN mode

It is possible to change data during the RUN mode according to the procedure described in ① above only for function codes  to ,  to , ,  and . However, it is possible to confirm the data of all function codes.

### (3) Display and Key Operation

#### 1) Operations and displays in each mode

The keypad panel modes can generally be classified into five types. The operation method and the display contents of each mode are shown below.

##### ① STOP mode

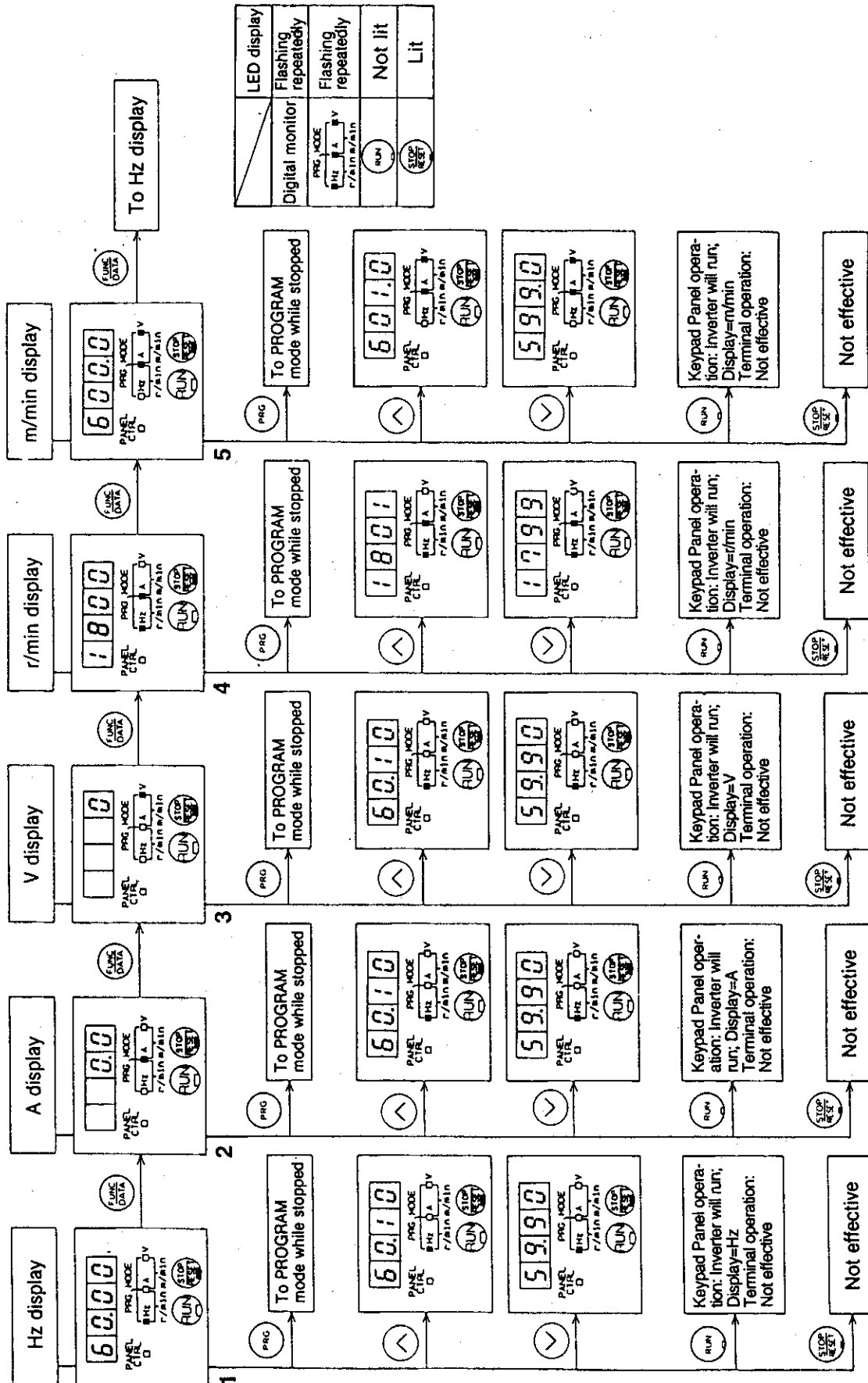

② RUN mode

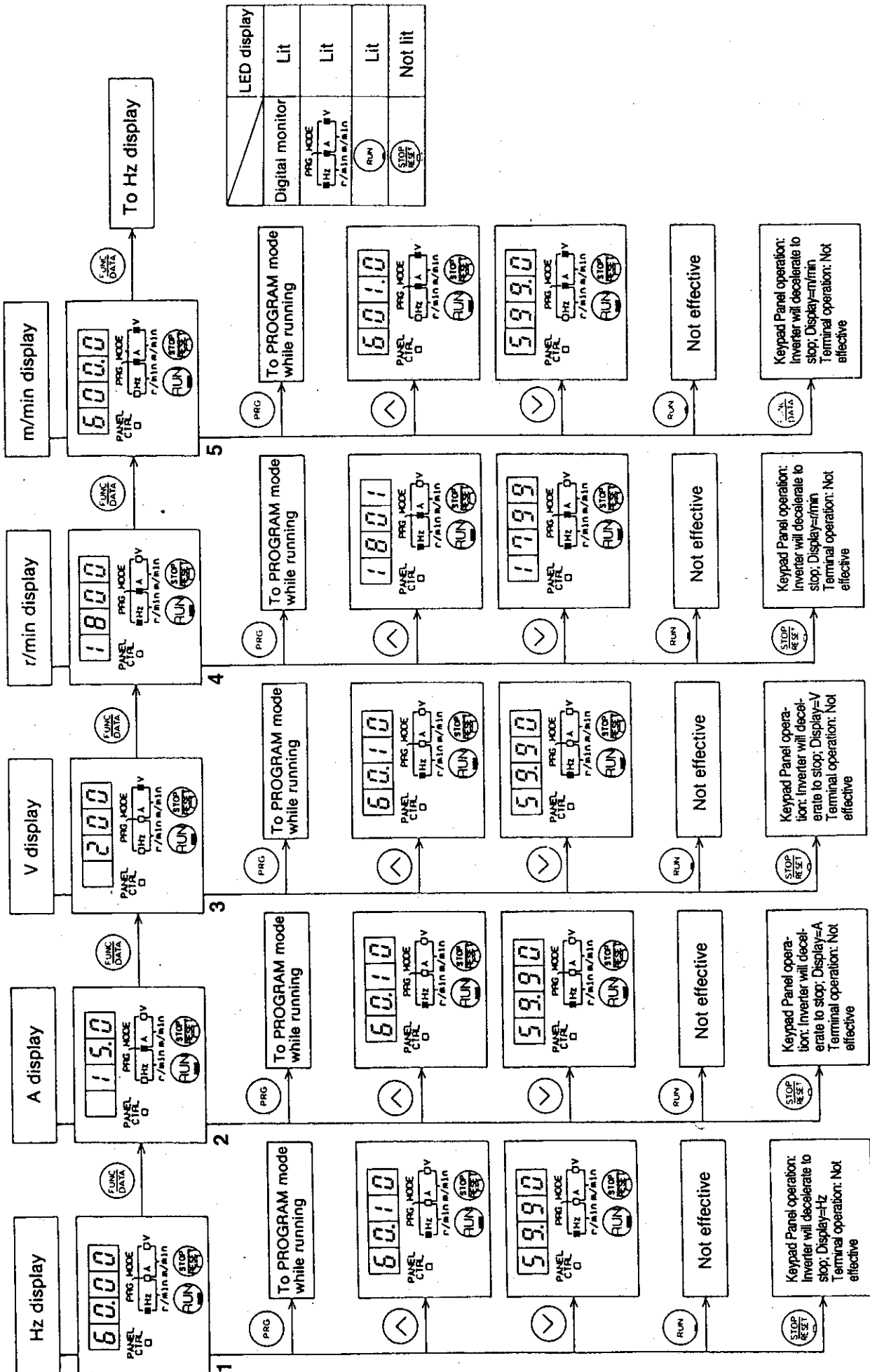

③ PROGRAM mode while stopped (example: changing the torque boost data value)

Function code is incremented by 1.

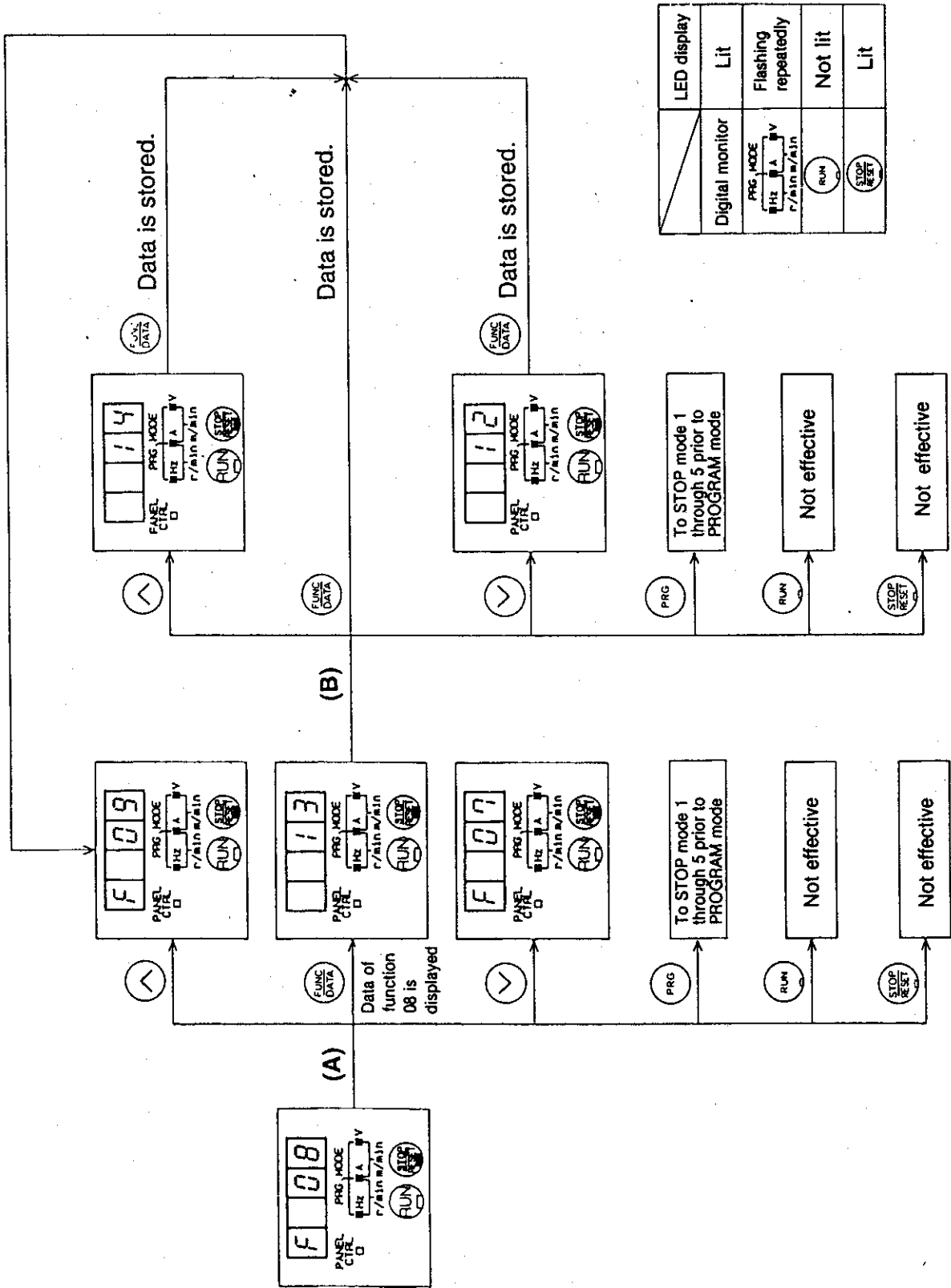

④ PROGRAM mode while running (example: changing the torque boost setting)

Function code is incremented by 1.

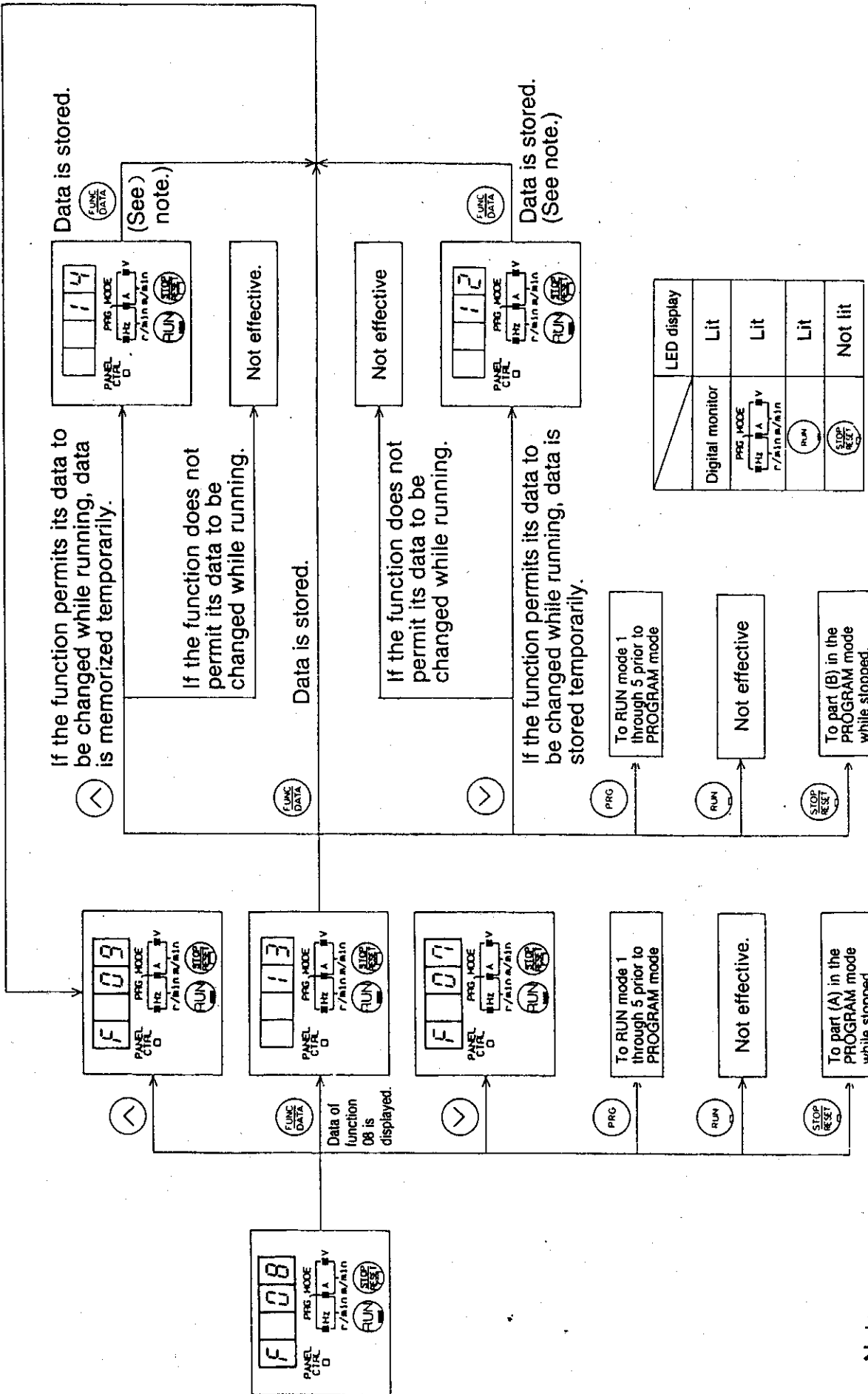

Note:

After changing function data with **PRG** keys, the **PRG** key must be pressed. If this is not done, the data will not be stored. If the **PRG** key is pressed before the **STOP/RESET** key is pressed, the changed data will be canceled and operation will continue with the previous data.

⑤ TRIP mode

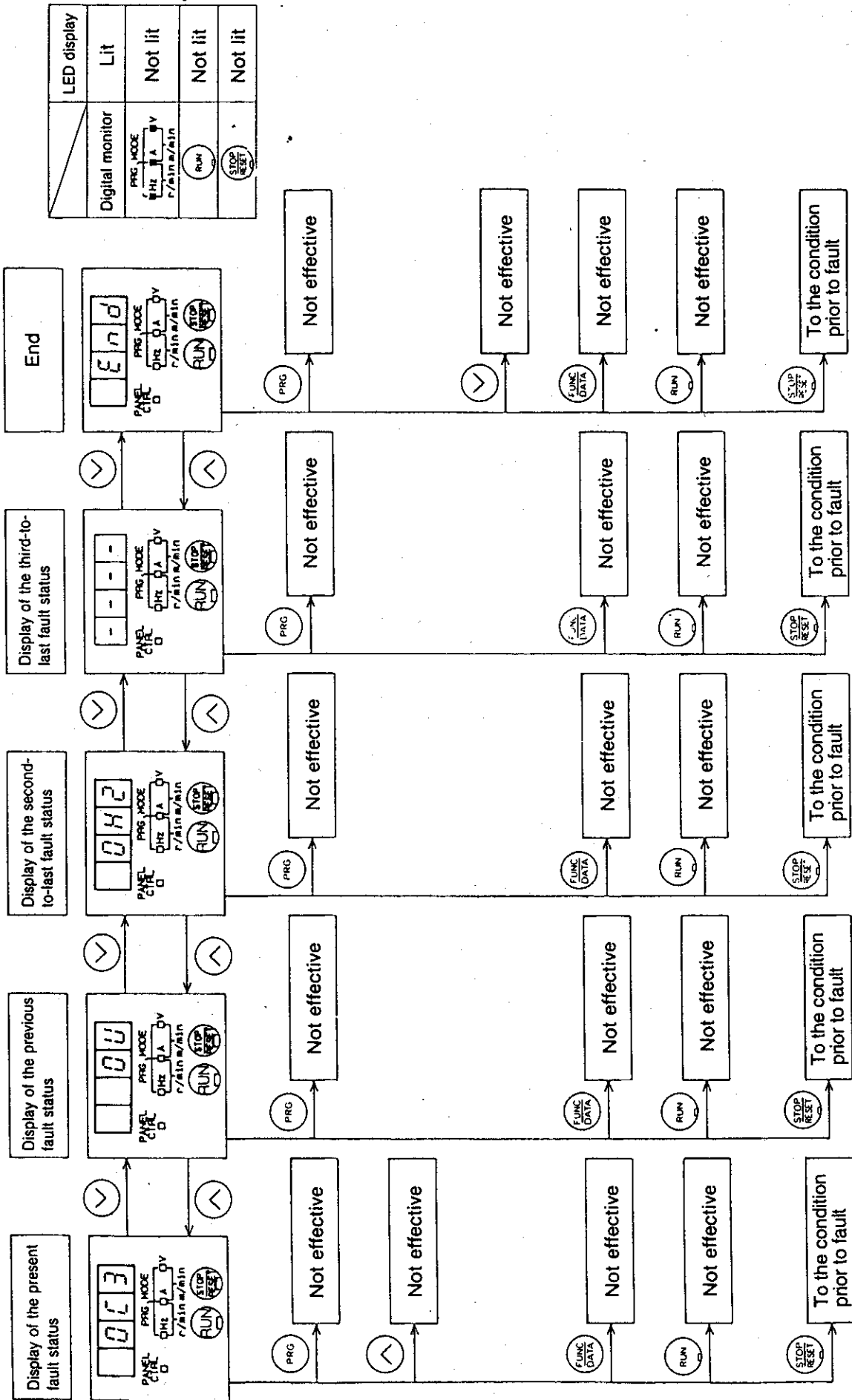

Note:  
Past fault records also can be displayed with function code 29.

2) Summary of each operation mode

The following table shows a summary of the various modes.

Indicators and keys		Mode	STOP mode	RUN mode	PROGRAM mode while stopped	PROGRAM mode while running	TRIP mode	
Display		Function	Display of output frequency, output current, output voltage, motor speed and line speed.		Display of function codes and data.		Display of fault status and fault memory.	
		Indication	Flashing repeatedly		Lit			
Keys		Function	Display of the unit for output frequency, output current, output voltage, motor speed and line speed.		Indication of PROGRAM mode while stopped		None	
		Indication	Flashing repeatedly				None	
		Function	Frequency:	 Flashing repeatedly	Flashing repeatedly			
		Indication	Current:	 Flashing repeatedly	Flashing repeatedly			
		Function	Voltage:	 Flashing repeatedly	Flashing repeatedly			
		Indication	Revolution speed:	 Flashing repeatedly	Flashing repeatedly			
Keys		Function	Line speed:	 Flashing repeatedly	Flashing repeatedly			Not lit
		Indication	Indication of whether keypad panel operation or terminal operation has been selected		Lit during keypad panel operation			None
		Function	Indication of stopped status		Indication of running status	Indication of stopped status	Indication of running status	Indication of fault status (stopped)
		Indication	Not lit Lit Change to PROGRAM mode while stopped.	Lit Not lit Change to PROGRAM mode while running.	Lit Lit Change to STOP mode.	Lit Not lit Change to RUN mode.	Not lit Lit Not effective	Not lit Not lit Not effective
		Function	Switch display of digital monitor and unit indication LED		Switch display between function code and data memorizing and function code incrementing Stores the data and renews the function code.			Not effective
		Function	Incrementing and decrementing of frequency, motor speed, and line speed settings		Incrementing and decrementing of function codes and data (stores the data temporarily)			Display of the fault memory
		Function	Change to RUN mode	Change to RUN mode	Not effective	Change to PROGRAM mode while stopped	Change to PROGRAM mode while stopped	TRIP mode cancellation, change to STOP mode or RUN mode
		Function	Not effective	Not effective	Not effective	Not effective	Not effective	Not effective
		Function	Change to RUN mode	Change to RUN mode	Not effective	Change to PROGRAM mode while stopped	Change to PROGRAM mode while stopped	TRIP mode cancellation, change to STOP mode or RUN mode
		Function	Not effective	Not effective	Not effective	Not effective	Not effective	Not effective

## 8. Operation

### (1) Pre-Operation Inspection

After completion of installation and wiring work, inspect the following items before the power supply to the inverter is switched on.

- ① Check for wiring errors. (Especially the main circuit wiring: connection of the three (single) phase AC power supply to the terminals L1, L2, L3 (L1, L2).)
- ② Check that all loose wire stands, metal chips and unnecessary screws, etc. have been removed.
- ③ Check that no screws, terminals, etc. are loose.
- ④ Check that the wire ends of crimp terminals are not in contact with other terminals

### Caution

#### Megger test:

**Do not conduct megger tests between the inverter main circuit terminals, or control circuit terminals. Refer to Section 10 "Inspection and Maintenance."**







### (2) Test Run Check Points

Use a low reference frequency setting of about 5 Hz for test operation to avoid danger. Please confirm the following items.

- ① Smooth rotation
- ② Correct rotation direction
- ③ No abnormal vibrations and noise from the motor
- ④ Smooth acceleration and deceleration

### (3) Selecting Operation Method

With the FVR-E7S Series, the following methods can be selected to input the run/stop signals and for frequency setting.

	Run/Stop	Data *1	Frequency setting	Data
1	Keypad panel operation		  keys	F 0 1 = □ □ □ □
2	  keys	F 0 2 = □ □ □ □	Analog signal (4 to 20 mA DC) + (0 to 10 V DC)	F 0 1 = □ □ □ □
3			Multistep speed selection by terminals X1, X2, and X3 *2	Either of the above data is acceptable.
4	Terminal operation (operation by external signal, FWD, REV terminals)	F 0 2 = □ □ □ □	  keys	F 0 1 = □ □ □ □
5			Analog signal (4 to 20 mA DC) + (0 to 10 V DC)	F 0 1 = □ □ □ □
6			Multistep speed selection by terminals X1, X2, and X3 *2	Either of the above data is acceptable.

#### Notes

\*1 : F 0 2 cannot be changed when there is a short circuit between either FWD-CM or REV-CM.

\*2 : Multistep speed operation (up to 8 steps are possible)

The frequencies of step 1 to step 7 are set with the function codes F 2 1 to F 2 7 and selected with the terminals X1, X2 and X3.

If input signals are provided to terminals X1, X2 and X3, then data setting of F 0 1 and F 0 2 and other settings made by keypad panel or analog signal are ignored, and multistep speed operation is controlled by these terminal signals.

#### (4) Setting Data Codes

Set data according to the following procedure with reference to "Controlling method" of Section 7 "Keypad Panel."

- ① Press the **PRG** key to switch to PROGRAM mode.
- ② Each time the **FUNC DATA** key is pressed, the display changes between indication of a function code and indication of the corresponding data.  
( **F 000** → **000** → **F 001** → **000** → --- )
- ③ Whenever data is displayed, it can be changed with the **▲** and **▼** keys.
- ④ When the **FUNC DATA** key is pressed, the changed data will be stored and the function code will be incremented.
- ⑤ When a function code is displayed as in step ② above, if the **▲** and **▼** keys are pressed, the function code is changed sequentially.  
( **F 000** → **F 001** → **F 002** → **F 003** → --- )

#### Notes:

1. To control run/stop and frequency setting through the control circuit terminals, set function codes 1 and 2 as follows:  
**F 001** = **0001** and **F 002** \* = **0001** .
2. To control run/stop through the keypad panel and frequency setting through the control circuit terminals, set function codes 1 and 2 as follows:  
**F 001** = **0001** and **F 002** \* = **0000** .
3. To control run/stop through the control circuit terminals and frequency setting through the keypad panel, set function codes 1 and 2 as follows:  
**F 001** = **0000** and **F 002** \* = **0001** .

\* To change **F 002**, open the connections between both FWD-CM and REV-CM terminals.

#### Note:

In order to achieve optimum operation of the inverter (including the motor), several other settings should be changed in addition to **F 001** and **F 002** .  
Although detailed information on the data settings is given in Section 9 "Function Explanation," in addition to **F 001** and **F 002** , it is important to check the values for the basic functions, **F 003** , **F 004** , **F 005** , **F 006** , **F 007** , etc.

#### (5) Control Circuit Connection And Operation

- ① Factory connections

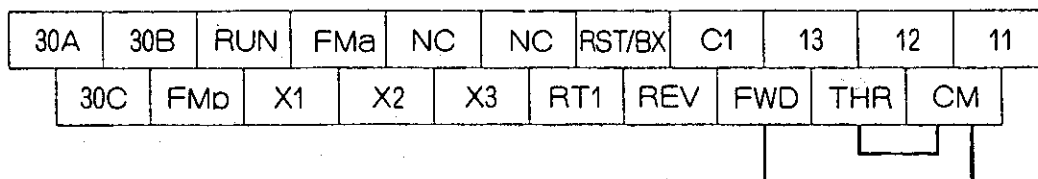

**F 001** = **0000** , **F 002** = **0000**

Basic connection required for keypad operation.

② Common terminal connection example irrespective of operation method

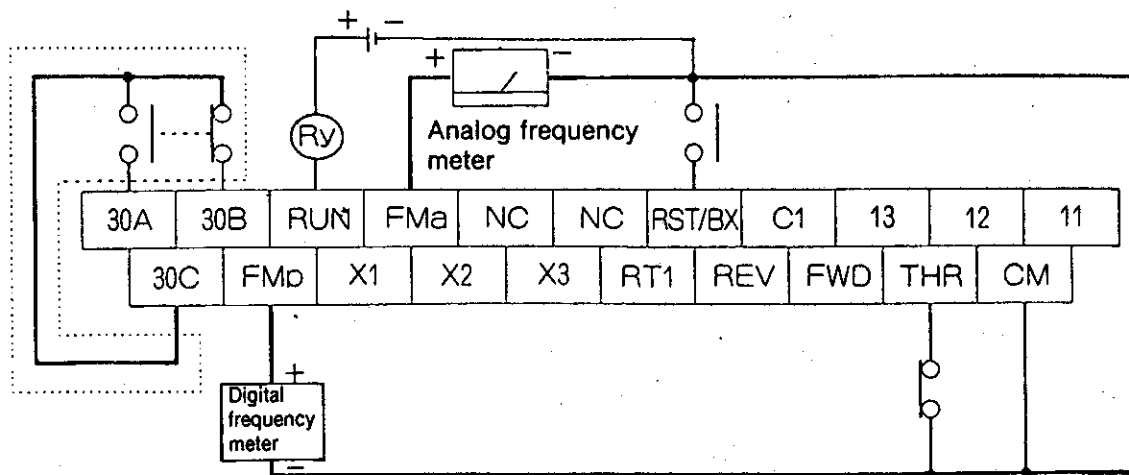

Internal circuit

30A, 30B, 30C ... When the inverter protection function is active and the inverter is stopped, the contact signal (SPDT contact) is output. This is used for alarm circuits etc.

FMa ..... Used when the frequency is to be displayed with an external analog meter.

FMp ..... Used when the frequency is to be displayed with an external digital counter. Note: However, simultaneous use of FMa and FMp is not possible, so only one should be selected. (Function code 28)

THR ..... At the time of shipping, this is connected to the terminal CM. When the inverter is to be stopped by an external signal, connect a NC (normally closed) contact.

RST/BX ..... Connect the NO (normally open) contact signal to cancel fault condition, or to cause the motor to coast to a stop while running.

RUN ..... When the inverter is running, the transistor is turned on: open collector output.

③ Operation through keypad panel (for  $F002 = \square\square\square$ )

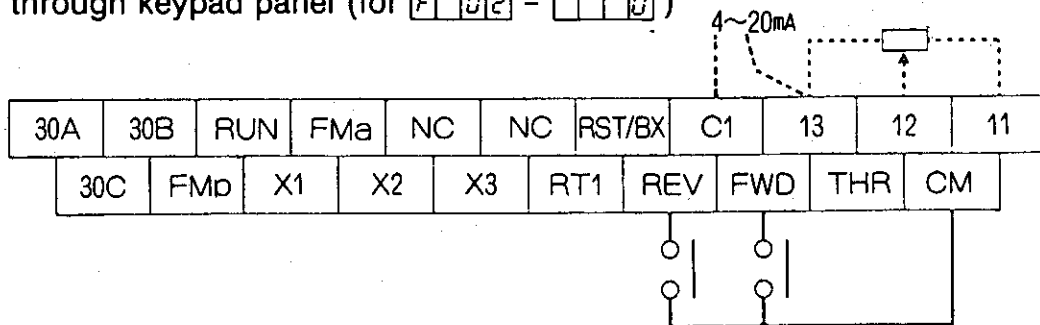

- The connection of the common terminals is the same as explained in section 5- ② above.
- The direction of rotation is forward when short-circuited between FWD and CM, and reverse when short-circuited between REV and CM.
- For the setting of the frequency, either of the following two methods can be selected by using function code  $F001$ .

$\square\square\square$  : Digital setting using the  $\Delta$  and  $\nabla$  keys.

$\square\square\square$  : Setting by adding the DC current signal of 4 to 20 mA between terminals C1 and 11 (C1 is the plus side) and the DC voltage signal of DC 0 to +10 V between terminals 12 and 11 (12 is plus polarity).

d. Operation example (for  $F01 = 0$ )

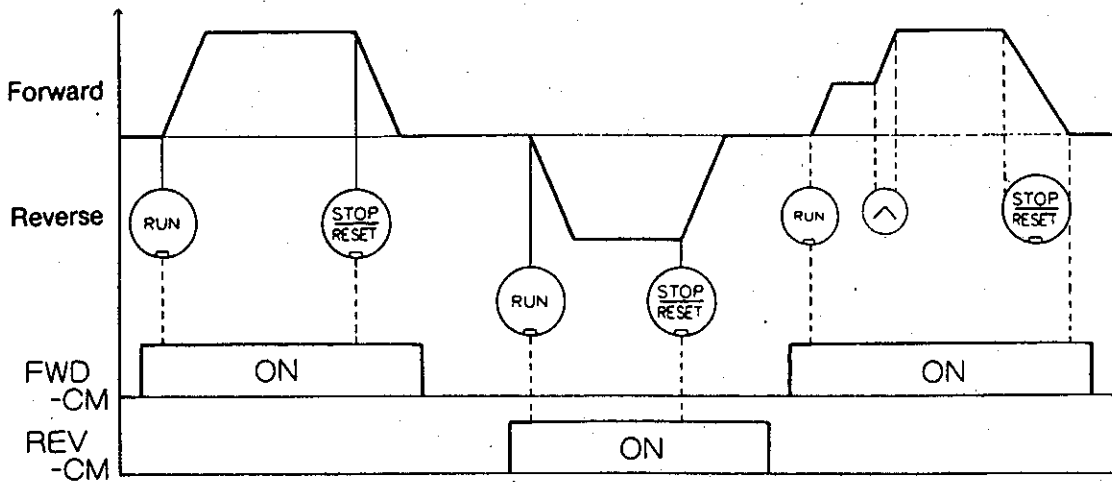

If both FWD-CM and REV-CM are either ON or OFF, inverter will decelerate to stop.

④ External Signal Operation (when  $F02 = 1$ )

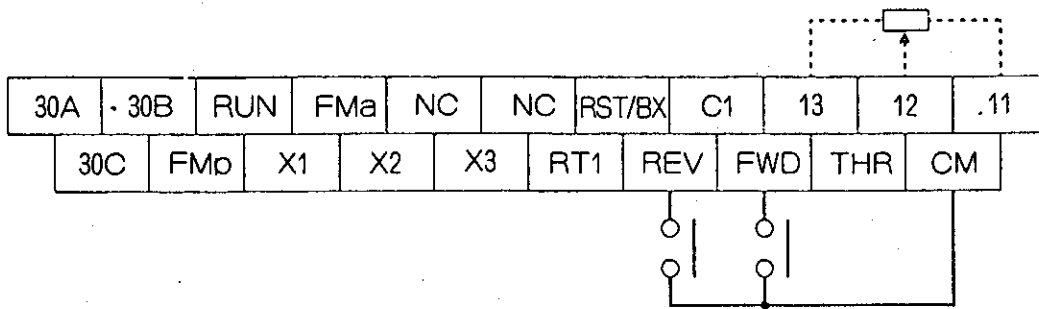

- The connection of the common terminals is the same as explained in section 5- ② above.
- The direction of rotation is forward when short-circuited between FWD and CM, and reverse when short-circuited between REV and CM.
- For the setting of the frequency, either of the two methods can be selected as described in section 5- ③.
- Operation example

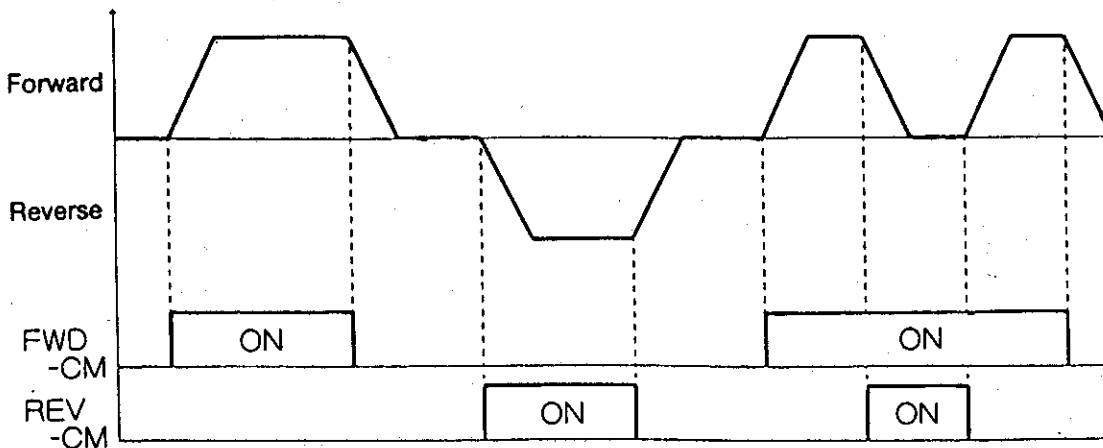

If both FWD-CM and REV-CM are either ON or OFF, inverter will decelerate to stop.

## (6) Actual Operation

- ① Multistep speed operation (application of terminals X1, X2, and X3)  
 Multistep speed operation is possible in 8 steps.

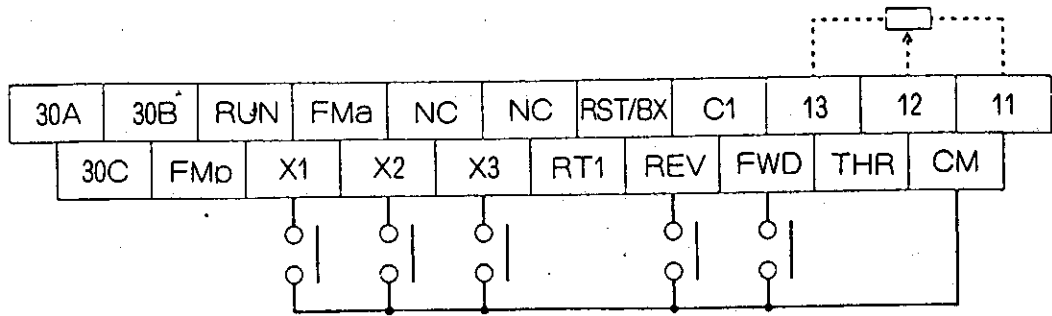

- Operation control method is selected by  $F \square 0 \square 2$ , and the frequency setting method is selected between keypad panel setting or analog setting by  $F \square 0 \square 1$ .
- Multistep speed settings 1 through 7 are set by  $F \square 2 \square 1$  through  $F \square 2 \square 7$ , respectively.
- Selection between forward operation and reverse operation is possible by switching between FWD-CM being ON and REV-CM being ON.
- Operation example

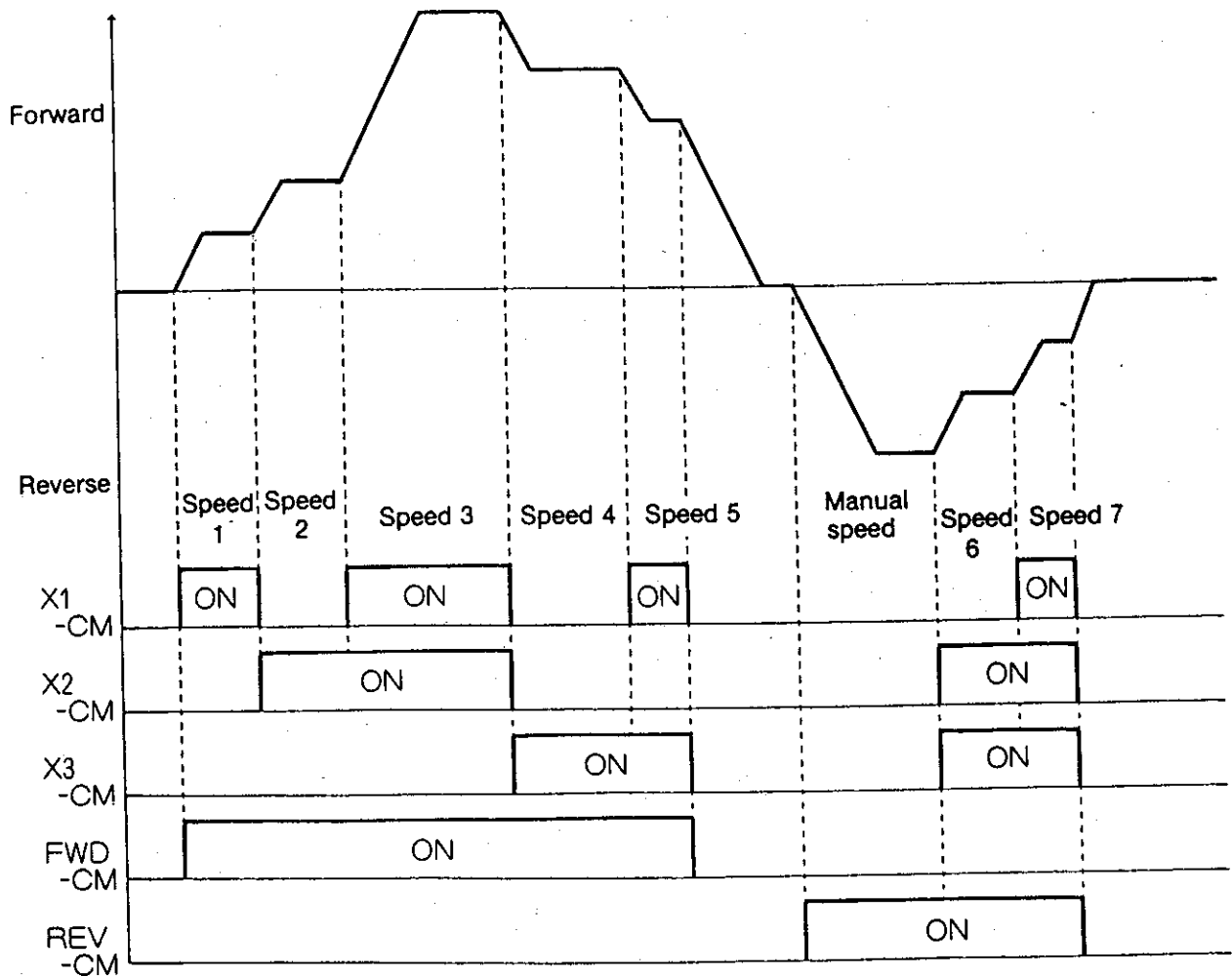

- ② Alternative Acceleration/Deceleration Operation (Terminal RT1)  
 The acceleration and deceleration time can be switched by an external signal.

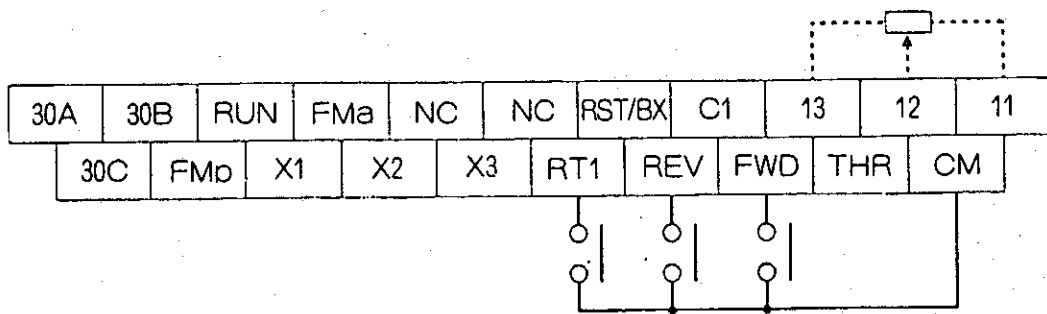

- Operation control method is selected by  $F \square 0 \square 2$ , and the frequency setting method is selected by  $F \square 0 \square 1$ .
- Acceleration time 1 is set by  $F \square 0 \square 5$ , deceleration time 1 is set by  $F \square 0 \square 7$ , and acceleration/deceleration time 2 is set by  $F \square 1 \square 3$ .  
 For acceleration/deceleration time 2, the acceleration time and the deceleration time are the same.
- Can also be used in combination with the multistep frequency operation described in ① above.
- Operation example

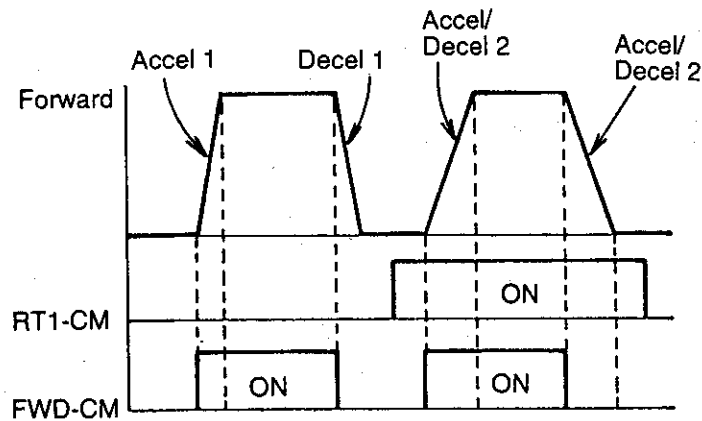

## 9. Function Explanation

### (1) Function Code Tables







Function code	Function	Data code, range	Units	Factory setting	Change during operation	Remarks
F 00	Data protection	0 : Data change possible 1 : Data change not possible	—	0	Not possible	If "Data change not possible" is selected, changes will not be possible for any codes other than F 00 and F 29.
F 01	Frequency command	0 : Keypad panel setting 1 : Analog setting (voltage + current)	—	0		
F 02	Operation command	0 : Keypad panel operation 1 : Terminal operation	—	0		Possible to change when FWD-CM or REV-CM is open.
F 03	Maximum frequency	0 ~ 400 Hz	1 Hz	60		
F 04	Base frequency	0 ~ 400 Hz	1 Hz	60		
F 05	Maximum output voltage	0 : Output voltage is proportional to the power supply voltage 1 ~ 240 V: AVR is active 2 ~ 460 V: AVR is active	1 V 2 V	230 460		
F 06	Acceleration time 1	0.01 ~ 3600s	0.01s	6.00	Possible	
F 07	Deceleration time 1	0.01 ~ 3600s	0.01s	6.00		
F 08	Torque boost	0 ~ (code)	—	13		
F 09	FMA terminal output level calibration	0 ~ 31 (code)	—	85		Effective only when F 28 = 0000 is selected.
F 10	Number of motor poles	2 : 2 poles 8 : 8 poles 4 : 4 poles 10 : 10 poles 6 : 6 poles 12 : 12 poles	—	4		Motor synchronous speed (r/min) display.
F 11	Line speed display coefficient	0.01 ~ 200	0.01	0.01		Coefficient for displaying m/min.
F 12	Motor running sound (Carrier frequency change)	0 ~ 5 (code)	—	3		When changing from 3 to 4 or from 4 to 3, first stop the inverter, and then make the change.

Function code	Function	Data code, range	Units	Factory setting	Change during operation	Remarks
F 1 3	Acceleration/ deceleration time 2	0.01 ~ 3600s	0.01s	10.00	Possible	Effective when RT1- CM is closed.
F 1 4	Restart after momentary power failure	0 : Inactive 1 : Active	—	0	Not possible	
F 1 5	Electronic ther- mal overload relay	0 : Inactive 1, 2 : Active	—	0		1 : For standard 4 pole motor 2 : For Fuji FV motor
F 1 6	Electronic ther- mal overload relay level	30 ~ 105%	1%	90		
F 1 7	DC brake	0 : Inactive 1 : Active	—	0		
F 1 8	DC brake starting frequency	0 ~ 60 Hz	1Hz	0		
F 1 9	DC brake voltage	0 ~ 15 (code)	—	0		
F 2 0	DC braking time	0.01 ~ 30s	0.01s	0.10		
F 2 1	Multistep speed setting 1	0.00 ~ 400 Hz	0.01 Hz	10.00		Possible
F 2 2	Multistep speed setting 2			20.00		
F 2 3	Multistep speed setting 3			30.00		
F 2 4	Multistep speed setting 4			40.00		
F 2 5	Multistep speed setting 5			50.00		
F 2 6	Multistep speed setting 6			60.00		
F 2 7	Multistep speed setting 7			60.00		
F 2 8	Frequency meter output	0: Analog output (FMa) 1: Pulse output (FMp)	—	0	Not possible	

Function code	Function	Data code, range	Units	Factory setting	Change during operation	Remarks
F 29	Fault memory	The current and previous 3 fault events are displayed in order of occurrence.	—	—	Possible	
F 30	Starting frequency	0 ~ 15 Hz	1 Hz	1	Not possible	
F 31	Operating mode of current limiting	0 : Inactive 1 : Active (mode 1) 2 : Active (mode 2)	—	0		In mode 2 it is possible to set the F 33 response time.
F 32	Current limiting level	30 ~ 150%	1%	150		
F 33	Response time for current limiting mode 2	0 ~ 99	1	0		Setting for current limiting mode 2
F 34	Bias frequency	0 ~ 100%	1%	0		
F 35	Gain for frequency setting signal	0 ~ 200%	1%	100	Possible	
F 36	High limiter	0 ~ 100%	1%	100	Not possible	
F 37	Low limiter	0 ~ 100%	1%	0		
F 38	Motor characteristics	0 ~ 10	1	5	Possible	
F 39	Data initialization	0 : Inactive 1 : Active	—	0	Not possible	

## (2) Function Explanation

### ① Initial setting

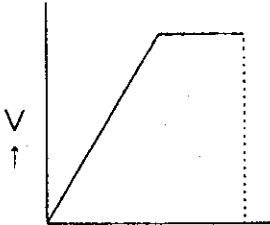
Function code	Data display	Function description	Factory set data
<p><b>F 00</b></p> <p>Data Protection</p>	<p><b>000</b></p> <p><b>000</b></p>	<p>The set data can be locked so that it will not be changed by mistake.</p> <p>Data change possible</p> <p>Data change not possible</p> <p>For this function only, the data is changed by simultaneously pressing the  key and either the  or  key.</p>	<b>000</b>
<p><b>F 01</b></p> <p>Frequency Command</p>	<p><b>000</b></p> <p><b>000</b></p>	<p>Either or the following two frequency setting methods can be selected.</p> <p>Keypad panel setting (  and  keys)</p> <p>Analog setting (sum of DC 0 to 10 V and DC 4 to 20 mA)</p>	<b>000</b>
<p><b>F 02</b></p> <p>Operation Command</p>	<p><b>000</b></p> <p><b>000</b></p>	<p>Either or the following two control methods can be selected.</p> <p>Keypad panel operation</p> <p>(  and  keys)</p> <p>Terminal operation (FWD, REV)</p> <p>Data can be changed when terminals FWD and REV on the terminal board are both OFF.</p> <p>The "PANEL CONTROL" LED will light up when data is set to <b>000</b>, and will remain off when set to <b>000</b>. (Refer to precaution on page 1.)</p>	<b>000</b>
<p><b>F 03</b></p> <p>Maximum Frequency</p>	<p><b>000</b></p> <p><b>400</b></p>	<p>Sets the maximum value for the output frequency.</p> <div style="text-align: center;">  <p>Maximum frequency → f</p> </div> <p>Frequency can be set in increments of 1 Hz within a range of 0 to 400 Hz.</p> <p>Multipurpose motors and other motors which are designed to operate at low speed can be damaged if operated at high frequency. Be sure to set the frequency to match the characteristics of the motor. <b>CAUTION: Consult Fuji For Operation Above 120 Hz.</b></p>	<b>0060</b>

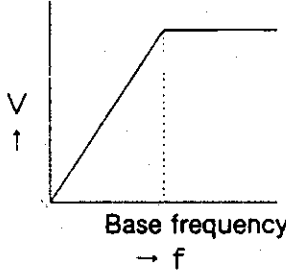
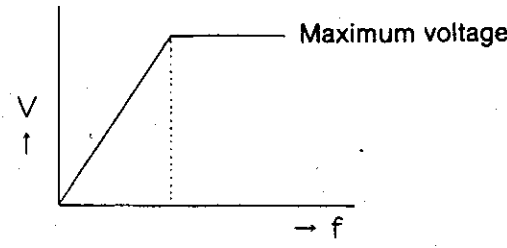
Function code	Data display	Function description	Factory set data										
<p>F 04</p> <p>Base Frequency</p>	<p>□ □ □ 0</p> <p>4 0 0</p>	<p>Sets the base frequency (the frequency which is the divergent point of the specified torque characteristics and the specified output characteristics).</p>  <p>Frequency can be set in increments of 1 Hz within a range of 0 to 400 Hz.</p> <ol style="list-style-type: none"> <li>① Set to match the characteristics of the motor. (Normally set to the rated frequency of the motor.)</li> <li>② Although the base frequency may exceed the maximum frequency, in that case the voltage will be decreased accordingly.</li> </ol>	<p>□ □ 6 0</p>										
<p>F 05</p> <p>Maximum Output Voltage</p>	<p>□ □ □ 0</p> <p>□ □ □ 1</p> <p>2 4 0</p> <p>□ □ □ 2</p> <p>4 6 0</p>	<p>Sets the maximum value for the output voltage.</p>  <p>If set to 0 V, the voltage proportional to the power supply voltage will be output.</p> <p>AVR operation. Voltage can be set in increments of 1 V (2V) within a range of 1 to 240 V. (2 to 460V)</p> <p>Output voltage cannot be higher than the power supply voltage.</p> <p>( ) : 400 V Series</p>	<p>□ □ 2 3 0</p> <p>□ □ 4 6 0</p>										
<p>F 06</p> <p>Acceleration Time 1</p> <p>F 07</p> <p>Deceleration Time 1</p>	<p>□ □ 0 0 1</p> <p>3 6 0 0</p>	<p>The time required to reach the maximum output frequency can be set within a range of 0.01 s to 3600 s.</p> <table border="1" data-bbox="635 1758 1316 2027"> <thead> <tr> <th>Set time</th> <th>Setting increments</th> </tr> </thead> <tbody> <tr> <td>0.01 ~ 9.99s</td> <td>0.01s</td> </tr> <tr> <td>10.00 ~ 99.90s</td> <td>0.1s</td> </tr> <tr> <td>100.0 ~ 999.0s</td> <td>1s</td> </tr> <tr> <td>1000 ~ 3600s</td> <td>10s</td> </tr> </tbody> </table> <p>Valid when RT1-CM is OFF.</p>	Set time	Setting increments	0.01 ~ 9.99s	0.01s	10.00 ~ 99.90s	0.1s	100.0 ~ 999.0s	1s	1000 ~ 3600s	10s	<p>□ □ 6 0 0</p> <p>□ □ 6 0 0</p>
Set time	Setting increments												
0.01 ~ 9.99s	0.01s												
10.00 ~ 99.90s	0.1s												
100.0 ~ 999.0s	1s												
1000 ~ 3600s	10s												

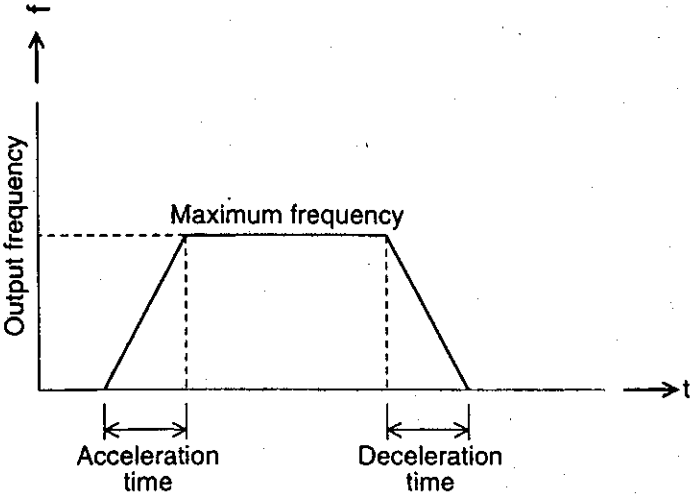
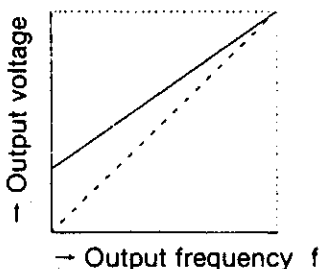
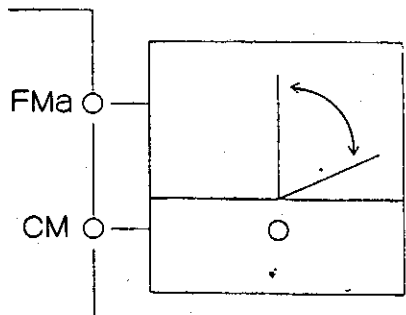
Function code	Data display	Function description	Factory set data
		<p>The set time is indicated as the time required to go from 0 Hz to the set maximum frequency value (set via <b>F 03</b>)</p> 	
<p><b>F 08</b> Torque Boost</p>	<p><b>0</b> <b>1</b> <b>2</b> <b>31</b></p>	<p>Can be set from among 32 different levels in accordance with the type of load, the characteristics of the motor, etc.</p> <p>For a reduced torque load (fan, pump, etc.).</p> <p>Low ↓ High</p>  <p>When using a Fuji FV motor designed for use with an inverter, set to <b>F 08</b>.</p>	<p><b>13</b></p>
<p><b>F 09</b> FMa Terminal Output Level Calibration</p>	<p><b>0</b> <b>99</b></p>	<p>Adjusts the level of the voltage output to terminal FMa for the frequency meter.</p> <p>Approx. 6.5 V ↓ Approx. 10.3 V</p> <p>Can be adjusted in increments of 0.01 V within this range.</p>  <p>This adjustment is valid only when <b>F 28</b> = <b>000</b> (analog output).</p>	<p><b>F 85</b></p>

Function code	Data display	Function description	Factory set data								
<p><b>F 10</b></p> <p>Number of Motor Poles</p>	<p><b>2</b></p> <p><b>4</b></p> <p><b>6</b></p> <p><b>8</b></p> <p><b>10</b></p> <p><b>12</b></p>	<p>Set the number of poles of the motor being used in order to provide rotation speed display synchronized with the motor.</p> <p>Example: Display when a 4-pole motor is operated at 60 Hz. <b>1800</b></p>	<p><b>4</b></p>								
<p><b>F 11</b></p> <p>Line Speed Display Coefficient</p>	<p><b>001</b></p> <p><b>200</b></p>	<p>The coefficient K for display of the line speed (m/min). Display value (m/min) = Output frequency (Hz) x K</p> <table border="1" data-bbox="901 788 1321 999"> <thead> <tr> <th>K</th> <th>Increments</th> </tr> </thead> <tbody> <tr> <td>0.01 ~ 9.99</td> <td>0.01</td> </tr> <tr> <td>10.00 ~ 99.90</td> <td>0.1</td> </tr> <tr> <td>100.0 ~ 200.0</td> <td>1.0</td> </tr> </tbody> </table> <p>Output frequency x 0.01 is displayed. } Output frequency x 200 is displayed. }</p> <p>If the value of the output frequency x K exceeds 9999, the display will read 9999.</p> <p>Example: When the output frequency is 100 Hz and K = 200. 100 Hz x K = 20000 → Display = <b>9999</b></p>	K	Increments	0.01 ~ 9.99	0.01	10.00 ~ 99.90	0.1	100.0 ~ 200.0	1.0	<p><b>001</b></p>
K	Increments										
0.01 ~ 9.99	0.01										
10.00 ~ 99.90	0.1										
100.0 ~ 200.0	1.0										
<p><b>F 12</b></p> <p>Motor Running Sound (Carrier Frequency Change)</p>	<p><b>0</b></p> <p><b>5</b></p>	<p>The sound of the motor operation can be changed by changing the carrier frequency.</p> <p>Select from among six levels in accordance with the usage conditions.</p> <p>Data code 0 to 3: Standard operation sound for a standard motor. 4: Low operation sound for a high-speed motor. 5: Low operation sound for a standard motor.</p> <p>Note that when using data code 4 or 5 for this function, it is recommended that the torque boost value be set to a lower value. When using data code 4 or 5, the inverter's continuous current rating as shown in "(1) Standard Specifications" in Section 12 "Appendix". When changing the data code from 3 to 4 or from 4 to 3, stop the inverter before making the change. (If this change is made while the inverter is operating, a trip will occur.)</p>	<p><b>3</b></p>								

Function code	Data display	Function description	Factory set data																																
F13 Acceleration/ Deceleration Time 2	0.01 3600	<p>Acceleration/deceleration time 2 can be set within a range of 0.01 s to 3600 s. However, the acceleration time and the deceleration time are the same.</p> <table border="1"> <thead> <tr> <th>Set time</th> <th>Setting increments</th> </tr> </thead> <tbody> <tr> <td>0.01 ~ 9.99s</td> <td>0.01s</td> </tr> <tr> <td>10.00 ~ 99.90s</td> <td>0.1s</td> </tr> <tr> <td>100.0 ~ 999.0s</td> <td>1s</td> </tr> <tr> <td>1000 ~ 3600s</td> <td>10s</td> </tr> </tbody> </table> <p>Acceleration/deceleration time 2 is valid when RT1-CM is ON.</p>	Set time	Setting increments	0.01 ~ 9.99s	0.01s	10.00 ~ 99.90s	0.1s	100.0 ~ 999.0s	1s	1000 ~ 3600s	10s	1000																						
Set time	Setting increments																																		
0.01 ~ 9.99s	0.01s																																		
10.00 ~ 99.90s	0.1s																																		
100.0 ~ 999.0s	1s																																		
1000 ~ 3600s	10s																																		
F14 Restart After Momentary Power Failure	0 1	<p>It is possible to select whether or not to restart operation when power supply is resumed after a momentary power failure.</p> <p>Inactive (If there is no operation command when power supply is restored: inverter stops. If there is an operation command after power supply is restored: undervoltage trip.)</p> <p>Active (After power supply is restored, the rotation speed of the free-running motor will be picked up and operation will be smoothly restarted.)</p> <p>Data code 1 is valid only if power supply is restored while LU is lit. The length of time that LU will remain lit after a power failure occurs is as follows.</p> <table border="1"> <thead> <tr> <th>Inverter model</th> <th>001</th> <th>002</th> <th>004</th> <th>008</th> <th>015</th> <th>022</th> <th>037</th> </tr> </thead> <tbody> <tr> <td>1Φ 200 V Series</td> <td>2.5s</td> <td>4.0s</td> <td>7.3s</td> <td>11s</td> <td>9s</td> <td>12s</td> <td>-</td> </tr> <tr> <td>3Φ 200 V Series</td> <td>0.7s</td> <td>0.7s</td> <td>1.4s</td> <td>1.4s</td> <td>2.0s</td> <td>3.5s</td> <td>3.5s</td> </tr> <tr> <td>3Φ 400 V Series</td> <td>-</td> <td>-</td> <td>0.9s</td> <td>1.7s</td> <td>1.7s</td> <td>1.9s</td> <td>2.3s</td> </tr> </tbody> </table>	Inverter model	001	002	004	008	015	022	037	1Φ 200 V Series	2.5s	4.0s	7.3s	11s	9s	12s	-	3Φ 200 V Series	0.7s	0.7s	1.4s	1.4s	2.0s	3.5s	3.5s	3Φ 400 V Series	-	-	0.9s	1.7s	1.7s	1.9s	2.3s	0
Inverter model	001	002	004	008	015	022	037																												
1Φ 200 V Series	2.5s	4.0s	7.3s	11s	9s	12s	-																												
3Φ 200 V Series	0.7s	0.7s	1.4s	1.4s	2.0s	3.5s	3.5s																												
3Φ 400 V Series	-	-	0.9s	1.7s	1.7s	1.9s	2.3s																												
<p><b>CAUTION</b> WHEN "RESTART AFTER MOMENTARY POWER FAILURE" IS DISABLED — FUNCTION CODE F14 SETTING IS 0, WITH THE TERMINALS CM-FWD OR REV CLOSED — RESETTING THE INVERTER, AFTER POWER SUPPLY HAS BEEN RECOVERED, WILL START THE INVERTER-DRIVEN MOTOR.</p>																																			
F15 Electronic Thermal Overload Relay	0 1 2	<p>Overheating protection is possible for a standard 4-pole motor and a Fuji FV motor designed for inverter use. (Protection possible across the entire frequency range.)</p> <p>Inactive</p> <p>Active (electronic thermal overload relay protection): For a standard 4-pole motor</p> <p>Active (electronic thermal overload relay protection): For a Fuji FV motor</p>	0																																

Function code	Data display	Function description	Factory set data
F 15 Electronic Thermal Overload Relay Level	30 105	Sets the operation level for the electronic thermal overload relay. Setting range: 30 to 105% (increments of 1%) $\text{Setting value (\%)} = K^{*1} \times \frac{\text{Motor's rated current}}{\text{Inverter's rated current}^{*2}}$	90

\*1 For models shown below, if the length of wiring between the inverter and the motor is long, use the values shown in the table below as compensation for the leakage current.

Series	Type	F 12 data	0 m	20 m	40 m	50 m	70 m	100 m	200 m
2EX 7EX	001	All data	K=1.2	K=1.2	K=1.2		External thermal OL relay is recommended.		
	002	All data	K=1	K=1	K=1	K=1.1	K=1.1	K=1.2	K=1.2
	004	All data	K=1	K=1	K=1	K=1	K=1	K=1.1	K=1.1
4EX	004	0, 1, 2 or 3	K=1	K=1	K=1	K=1	Not available		
		4 or 5	K=1	K=1.1	Not available				
	008	0, 1, 2 or 3	K=1	K=1	K=1	K=1	K=1	K=1	Not available
		4 or 5	K=1	K=1	Not available				

Note: For the other models, normally use K=1.

\*2 Use the normal rated output current values shown in the chart on page 43.

De-rating characteristics for the continuously allowable current

1) For a standard 4-pole motor ( )

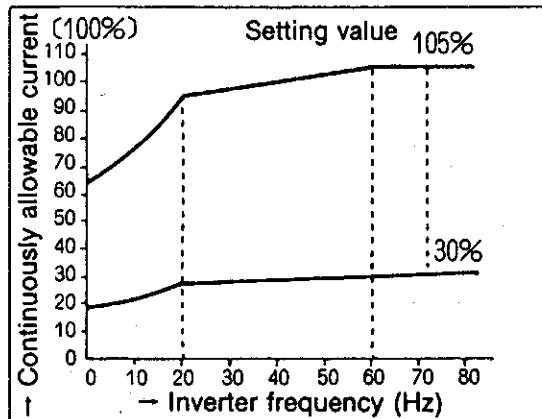

2) For a Fuji FV motor ( )

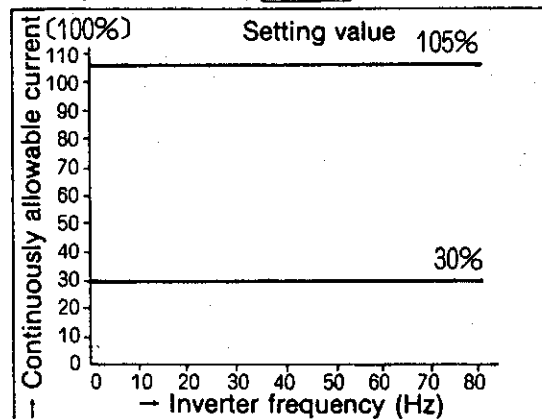

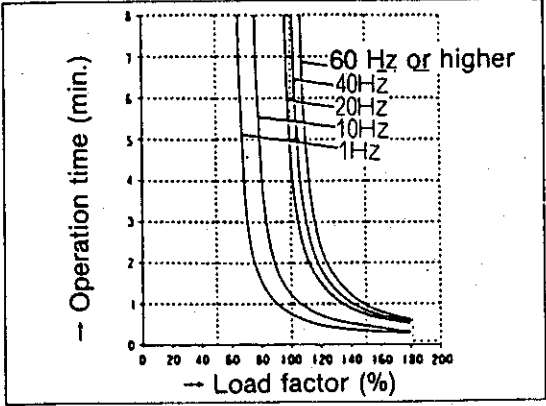
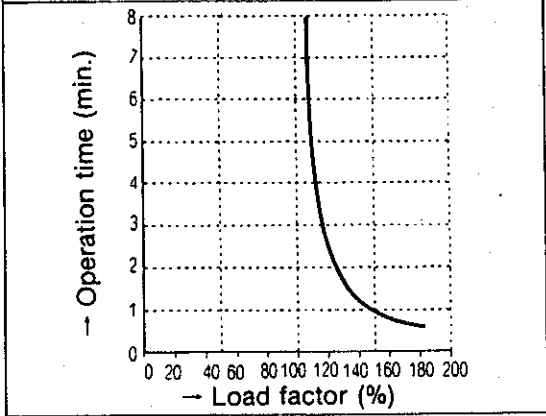
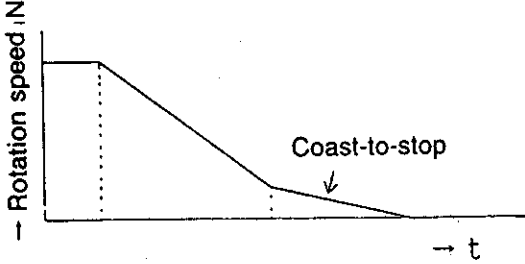
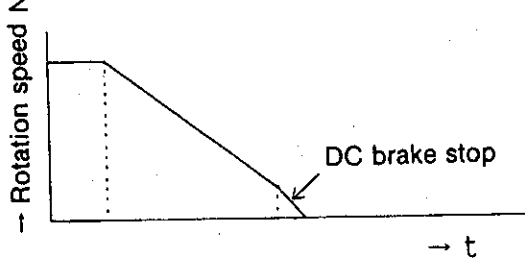
Function code	Data display	Function description	Factory set data
		<p>Electronic Thermal Overload Relay Operation Characteristics</p> <p>1) For a standard 4-pole motor ( <input type="text" value=""/><input type="text" value=""/><input type="text" value="1"/> )</p>  <p>2) For a Fuji FV motor ( <input type="text" value=""/><input type="text" value=""/><input type="text" value="2"/> )</p> 	
<p><input type="text" value="F"/><input type="text" value="1"/><input type="text" value="7"/></p> <p>DC Brake</p>	<p><input type="text" value=""/><input type="text" value="0"/></p> <p><input type="text" value=""/><input type="text" value="1"/></p>	<p>Selects whether or not the DC brake will operate.</p> <p>Inactive</p>  <p>Active</p> 	<p><input type="text" value=""/><input type="text" value="0"/></p>





Function code	Data display	Function description	Factory set data																				
F 1 8 DC Brake Starting Frequency	[ ][ ][ ] 0 [ ][ ] 5 0	The frequency at which DC braking starts can be set. DC brake starting frequency can be set in increments of 1 Hz within a range of 0 to 60 Hz. 	[ ][ ][ ] 0																				
F 1 9 DC Brake Voltage	[ ][ ][ ] 0 [ ][ ] 1 5	Weak ↓ Strong } DC brake strength can be set from among 16 levels. The strength of the brake will change in accordance with the characteristics of the motor.	[ ][ ][ ] 0																				
F 2 0 DC Braking Time	[ ][ ] 0 0 1 3 0 0 0	The braking time can be set within a range of 0.01 to 30 s. <table border="1"> <thead> <tr> <th>Setting range</th> <th>Setting increments</th> </tr> </thead> <tbody> <tr> <td>0.01 ~ 9.99s</td> <td>0.01s</td> </tr> <tr> <td>10.00 ~ 30.00s</td> <td>0.1s</td> </tr> </tbody> </table>	Setting range	Setting increments	0.01 ~ 9.99s	0.01s	10.00 ~ 30.00s	0.1s	[ ][ ] 0 1 0														
Setting range	Setting increments																						
0.01 ~ 9.99s	0.01s																						
10.00 ~ 30.00s	0.1s																						
F 2 1 Multistep Speed Setting 1 F 2 2 Multistep Speed Setting 2 F 2 3 Multistep Speed Setting 3 F 2 4 Multistep Speed Setting 4 F 2 5 Multistep Speed Setting 5 F 2 6 Multistep Speed Setting 6 F 2 7 Multistep Speed Setting 7	[ ][ ] 0 0 0 4 0 0 0	Multistep speeds can be set for 7 steps within a range of 0 to 400 Hz. Setting resolution <table border="1"> <thead> <tr> <th>Multistep setting resolution value</th> <th>0 ~ 1.000Hz</th> <th>1.000 ~ 10.00Hz</th> <th>10.00 ~ 100.0Hz</th> <th>100.0 ~ Hz</th> </tr> </thead> <tbody> <tr> <td>Maximum frequency</td> <td></td> <td></td> <td></td> <td></td> </tr> <tr> <td>300 Hz or less</td> <td>0.01Hz</td> <td>0.01Hz</td> <td>0.1Hz</td> <td>1Hz</td> </tr> <tr> <td>Above 300 Hz</td> <td>0.02Hz</td> <td>0.02Hz</td> <td>0.1Hz</td> <td>1Hz</td> </tr> </tbody> </table>	Multistep setting resolution value	0 ~ 1.000Hz	1.000 ~ 10.00Hz	10.00 ~ 100.0Hz	100.0 ~ Hz	Maximum frequency					300 Hz or less	0.01Hz	0.01Hz	0.1Hz	1Hz	Above 300 Hz	0.02Hz	0.02Hz	0.1Hz	1Hz	F 2 1    1 0 0 0 F 2 2    2 0 0 0 F 2 3    3 0 0 0
Multistep setting resolution value	0 ~ 1.000Hz	1.000 ~ 10.00Hz	10.00 ~ 100.0Hz	100.0 ~ Hz																			
Maximum frequency																							
300 Hz or less	0.01Hz	0.01Hz	0.1Hz	1Hz																			
Above 300 Hz	0.02Hz	0.02Hz	0.1Hz	1Hz																			

Function code	Data display	Function description	Factory set data																																																																																										
		(Relationship between terminals and multistep frequency 1 through 7)																																																																																											
		<table border="1"> <thead> <tr> <th>Function code</th> <th>01</th> <th>21</th> <th>22</th> <th>23</th> <th>24</th> <th>25</th> <th>26</th> <th>27</th> </tr> </thead> <tbody> <tr> <td>Multi-step frequency</td> <td>Keypad panel or analog signal</td> <td>Speed 1</td> <td>Speed 2</td> <td>Speed 3</td> <td>Speed 4</td> <td>Speed 5</td> <td>Speed 6</td> <td>Speed 7</td> </tr> <tr> <td>X1-CM</td> <td>OFF</td> <td>ON</td> <td>OFF</td> <td>ON</td> <td>OFF</td> <td>ON</td> <td>OFF</td> <td>ON</td> </tr> <tr> <td>X2-CM</td> <td>OFF</td> <td>OFF</td> <td>ON</td> <td>ON</td> <td>OFF</td> <td>OFF</td> <td>ON</td> <td>ON</td> </tr> <tr> <td>X3-CM</td> <td>OFF</td> <td>OFF</td> <td>OFF</td> <td>OFF</td> <td>ON</td> <td>ON</td> <td>ON</td> <td>ON</td> </tr> </tbody> </table>	Function code	01	21	22	23	24	25	26	27	Multi-step frequency	Keypad panel or analog signal	Speed 1	Speed 2	Speed 3	Speed 4	Speed 5	Speed 6	Speed 7	X1-CM	OFF	ON	OFF	ON	OFF	ON	OFF	ON	X2-CM	OFF	OFF	ON	ON	OFF	OFF	ON	ON	X3-CM	OFF	OFF	OFF	OFF	ON	ON	ON	ON	<table border="1"> <tr><td>F</td><td>2</td><td>4</td></tr> <tr><td colspan="3">  </td></tr> <tr><td>4</td><td>0</td><td>0</td></tr> <tr><td colspan="3">  </td></tr> <tr><td>F</td><td>2</td><td>5</td></tr> <tr><td colspan="3">  </td></tr> <tr><td>5</td><td>0</td><td>0</td></tr> <tr><td colspan="3">  </td></tr> <tr><td>F</td><td>2</td><td>6</td></tr> <tr><td colspan="3">  </td></tr> <tr><td>6</td><td>0</td><td>0</td></tr> <tr><td colspan="3">  </td></tr> <tr><td>F</td><td>2</td><td>7</td></tr> <tr><td colspan="3">  </td></tr> <tr><td>6</td><td>0</td><td>0</td></tr> </table>	F	2	4				4	0	0				F	2	5				5	0	0				F	2	6				6	0	0				F	2	7				6	0	0
Function code	01	21	22	23	24	25	26	27																																																																																					
Multi-step frequency	Keypad panel or analog signal	Speed 1	Speed 2	Speed 3	Speed 4	Speed 5	Speed 6	Speed 7																																																																																					
X1-CM	OFF	ON	OFF	ON	OFF	ON	OFF	ON																																																																																					
X2-CM	OFF	OFF	ON	ON	OFF	OFF	ON	ON																																																																																					
X3-CM	OFF	OFF	OFF	OFF	ON	ON	ON	ON																																																																																					
F	2	4																																																																																											
4	0	0																																																																																											
F	2	5																																																																																											
5	0	0																																																																																											
F	2	6																																																																																											
6	0	0																																																																																											
F	2	7																																																																																											
6	0	0																																																																																											
		<p>① If X1-CM, X2-CM, and X3-CM are all OFF, the setting is made by either the keypad panel (⊙ and ⊙ keys) or the analog signal (sum of DC 0 to +10 V plus 4 to 20 mA), as selected via function <b>F 0 1</b>.</p> <p>② The setting cannot exceed the maximum frequency set by function <b>F 0 3</b>. If the maximum frequency setting is lower than a multistep speed setting, the multistep speed will automatically be set to the same value as the maximum frequency, and the previously set value will be erased.</p>																																																																																											
<b>F 2 8</b> Frequency Meter Output	<table border="1"> <tr><td> </td><td> </td><td> </td><td>0</td></tr> <tr><td> </td><td> </td><td> </td><td>1</td></tr> </table>				0				1	<p>The output frequency signal type can be selected.</p> <p>Analog voltage output from terminal FMa (for an analog frequency meter). The voltage is adjusted by function <b>F 0 9</b>.</p> <p>Pulse voltage output from terminal FMp (for a digital frequency meter).</p>	<table border="1"> <tr><td> </td><td> </td><td> </td><td>0</td></tr> </table>				0																																																																														
			0																																																																																										
			1																																																																																										
			0																																																																																										

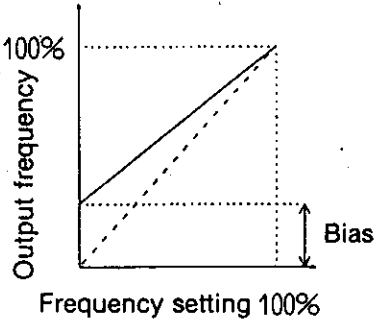
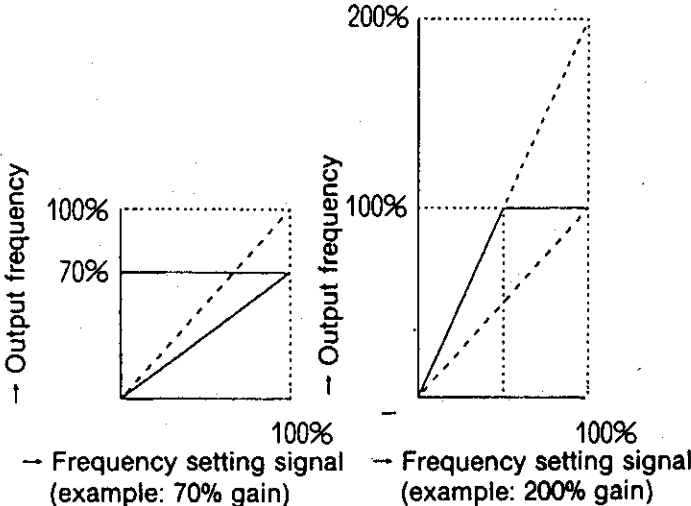
Function code	Data display	Function description	Factory set data																												
<p data-bbox="204 183 320 226">F 2 9</p> <p data-bbox="124 237 312 271">Fault memory</p>		<p data-bbox="592 192 1318 327">The current and previous 3 fault events are stored in memory. The data for each can be displayed by using the <math>\odot</math> key. The procedure for displaying the data is as follows.</p> <table border="1" data-bbox="592 353 1326 1238"> <thead> <tr> <th>No.</th> <th>Procedure</th> <th>Display example</th> <th>Remarks</th> </tr> </thead> <tbody> <tr> <td>1</td> <td>Display F 2 9</td> <td>F 2 9</td> <td></td> </tr> <tr> <td>2</td> <td>Press the <math>\odot</math> key. ↓ Press the <math>\triangle</math> key.</td> <td>0 0 0</td> <td>The information for the latest trip will be displayed.</td> </tr> <tr> <td>3</td> <td>Press the <math>\odot</math> key. ↓ Press the <math>\triangle</math> key.</td> <td>0 H 2</td> <td>The information for the first preceding trip will be displayed.</td> </tr> <tr> <td>4</td> <td>Press the <math>\odot</math> key. ↓ Press the <math>\triangle</math> key.</td> <td>0 E 1</td> <td>The information for the second preceding trip will be displayed.</td> </tr> <tr> <td>5</td> <td>Press the <math>\odot</math> key. ↓ Press the <math>\triangle</math> key.</td> <td>- - -</td> <td>The information for the third preceding trip will be displayed. (In this example, there is no history of a third preceding trip.)</td> </tr> <tr> <td>6</td> <td>Press the <math>\odot</math> key.</td> <td>E n d</td> <td></td> </tr> </tbody> </table> <p data-bbox="592 1274 1299 1444">The information for any new trip will be stored in the area for the "information for the latest trip" shown above, each trip history will be moved downward, and the "information for the third preceding trip" will be erased.</p>	No.	Procedure	Display example	Remarks	1	Display F 2 9	F 2 9		2	Press the $\odot$ key. ↓ Press the $\triangle$ key.	0 0 0	The information for the latest trip will be displayed.	3	Press the $\odot$ key. ↓ Press the $\triangle$ key.	0 H 2	The information for the first preceding trip will be displayed.	4	Press the $\odot$ key. ↓ Press the $\triangle$ key.	0 E 1	The information for the second preceding trip will be displayed.	5	Press the $\odot$ key. ↓ Press the $\triangle$ key.	- - -	The information for the third preceding trip will be displayed. (In this example, there is no history of a third preceding trip.)	6	Press the $\odot$ key.	E n d		<p data-bbox="1358 183 1474 226">- - -</p>
No.	Procedure	Display example	Remarks																												
1	Display F 2 9	F 2 9																													
2	Press the $\odot$ key. ↓ Press the $\triangle$ key.	0 0 0	The information for the latest trip will be displayed.																												
3	Press the $\odot$ key. ↓ Press the $\triangle$ key.	0 H 2	The information for the first preceding trip will be displayed.																												
4	Press the $\odot$ key. ↓ Press the $\triangle$ key.	0 E 1	The information for the second preceding trip will be displayed.																												
5	Press the $\odot$ key. ↓ Press the $\triangle$ key.	- - -	The information for the third preceding trip will be displayed. (In this example, there is no history of a third preceding trip.)																												
6	Press the $\odot$ key.	E n d																													
<p data-bbox="212 1487 331 1529">F 3 0</p> <p data-bbox="132 1541 384 1574">Starting Frequency</p>	<p data-bbox="451 1798 568 1841">0</p> <p data-bbox="451 1861 568 1904">15</p>	<p data-bbox="592 1496 1326 1599">The starting frequency can be set in increments of 1 Hz within a range of 0 to 15 Hz. However, when set to 0, starting will occur at 0.2 Hz.</p> <p data-bbox="592 1599 1310 1668">Note that stopping will also occur at the frequency set by this function.</p> <div data-bbox="820 1720 1235 1980"> <p data-bbox="820 1720 847 1944">Output frequency</p> <p data-bbox="820 1798 847 1832">0.2 Hz</p> <p data-bbox="820 1861 847 1895">15 Hz</p> <p data-bbox="1007 1854 1235 1888">Starting frequency</p> <p data-bbox="1134 1951 1190 1980">t</p> </div> <p data-bbox="592 2024 1177 2060">Set to 2 Hz when using a high-speed motor.</p>	<p data-bbox="1362 1487 1479 1529">0 0 1</p>																												

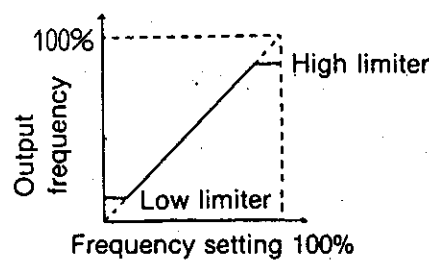
Function code	Data display	Function description	Factory set data
<p><b>F 3 1</b></p> <p>Operating mode of current limiting</p>	<p>□ □ □ 0</p> <p>□ □ □ 1</p> <p>□ □ □ 2</p>	<p>When the output current reaches the current limiting level, the output frequency will be automatically lowered in order to avoid an overcurrent trip.</p> <p>Inactive</p> <p>Active (mode 1): Operates with respect to the increase in the output current during acceleration and during fixed speed.</p> <p>Active (mode 2): Operates with respect to the increase in the output current during fixed speed.</p> <p>For the rate of decrease of the frequency during current limiting operation, for mode 1 it is proportional to a value determined using the set deceleration time as a base. For mode 2, it is set by function <b>F 3 3</b>.</p> <div data-bbox="673 741 1216 1153" data-label="Figure"> </div>	<p>□ □ □ 0</p>
<p><b>F 3 2</b></p> <p>Current Limiting Level</p>	<p>□ □ □ 30</p> <p>□ □ □ 50</p>	<p>Can be set in increments of 1% within a range of 30 to 150% of the inverter's rated current (standard value). The current limiting function will operate until the output current reaches the value set by this function.</p>	<p>□ □ □ 150</p>
<p><b>F 3 3</b></p> <p>Response Time For Current Limiting Mode 2</p>	<p>□ □ □ 1</p> <p>□ □ □ 99</p>	<p>Sets the rate of decrease of the output frequency during operation of the current limiting function. Valid only when <b>F 3 1</b> = □ □ □ 2.</p> <p>Note that when the restart after momentary power failure function is used (<b>F 1 4</b> = □ □ □ 1), this set value is also used for the rate of decrease of the frequency when the power supply is restored.</p> <p>Fast</p> <p>↓</p> <p>Slow (good stability)</p> <p>The frequency is decreased using as a base the time calculated by:</p> <p>(Data value +1) x 0.2 s for data codes 0 through 48</p> <p>(Data value -49) x 2 + 10 s for data codes 49 through 99</p>	<p>□ □ □ 0</p>

Function code	Data display	Function description	Factory set data
<p><b>F 34</b></p> <p>Bias Frequency</p>	<p>□ □ □ 0</p> <p>□ 1 0 0</p>	<p>Outputs a bias frequency with respect to the analog frequency setting.</p> <p>Set as a percentage of the maximum frequency in increments of 1% within a range of 0 to 100%.</p> 	<p>□ □ □ 0</p>
<p><b>F 35</b></p> <p>Gain For Frequency Setting Signal</p>	<p>□ □ □ 0</p> <p>□ 2 0 0</p>	<p>Outputs a frequency which is a proportional ratio of the analog frequency setting.</p> <p>Set as a percentage of the maximum frequency in increments of 1% within a range of 0 to 200%. (However, a frequency higher than the maximum frequency is not output.)</p> <p>Capable of handling a range of DC 0 to +5 V.</p>  <p>When used together with the frequency setting bias (<b>F 34</b>), this frequency setting gain takes priority, and the bias is applied to the frequency after the gain has been applied.</p>	<p>□ 1 0 0</p>

Function code	Data display	Function description	Factory set data								
<p>F 3 6</p> <p>High limiter</p> <p>F 3 7</p> <p>Low limiter</p>	<p>□ □ □ 0</p> <p>□ □ □ 0</p>	<p>The upper and lower limits of the output frequency can be set.</p> <p>Set as a percentage of the maximum frequency in increments of 1% within a range of 0 to 100%.</p>  <p>If the value set for the low limiter is higher than that set for the high limiter, the high limiter will take priority and the low limiter will be ignored. Thus, operation will always be in accordance with the high limiter value regardless of the frequency setting.</p>	<p>□ □ □ 0</p> <p>□ □ □ 0</p>								
<p>F 3 8</p> <p>Motor characteristics</p>	<p>□ □ □ 0</p> <p>□ □ □ 0</p>	<p>Used to adjust in the event that a problem such as current vibration, etc., occurs in the output current.</p> <p>Low setting value</p> <p>High setting value</p> <p>If current vibration occurs, refer to the following information to adjust the set value.</p> <table border="1" data-bbox="598 1344 1308 1467"> <tr> <td>Number of motor poles</td> <td>Higher → 4 → lower</td> <td>Load</td> <td>High → low</td> </tr> <tr> <td>Setting value</td> <td>0 → 10</td> <td>Setting value</td> <td>0 → 10</td> </tr> </table>	Number of motor poles	Higher → 4 → lower	Load	High → low	Setting value	0 → 10	Setting value	0 → 10	<p>□ □ □ 5</p>
Number of motor poles	Higher → 4 → lower	Load	High → low								
Setting value	0 → 10	Setting value	0 → 10								
<p>F 3 9</p> <p>Data initialization</p>	<p>□ □ □ 0</p> <p>□ □ □ 1</p>	<p>Resets the data for all of the functions to the values set at the factory.</p> <p>Inactive</p> <p>Resets to the values set at the factory.</p> <p>From the □ □ □ 0 display, by simultaneously pressing  and , the display will change to □ □ □ 1. By pressing  in this state, the data will be reset to the values set at the factory, and the mode will automatically change to the  frequency display mode.</p>	<p>□ □ □ 0</p>								

## 10. Maintenance and Inspection

In order to ensure a long service life and proper operation of the inverter, and also to prevent problems before they occur, carry out the following inspections.

### Caution:

**Before inspecting the inverter, switch off the power supply and confirm that the "CRG" lamp has gone out.  
To see the "CRG" lamp, remove the terminal cover (see page 3).**

### Megger test

- ① When conducting a megger test on external circuits, disconnect all of the inverter terminals and perform the test in such a manner that the test voltage is not applied to the inverter.
- ② To conduct a megger test on the inverter itself, perform the test only on the main circuit using the procedure shown below. Do not perform a megger test on the control circuits.
- ③ To perform a continuity test on the control circuits, use a tester (high-resistance range type), and do not use a megger or a buzzer.

Megger test outline for 2AX, 4AX

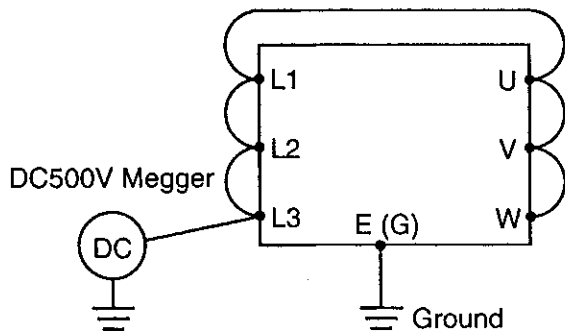

Megger test outline for 7AX

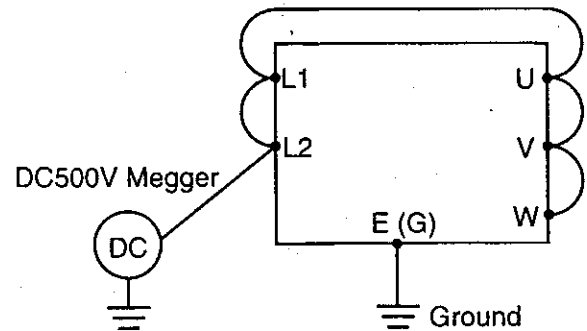

### (1) Inspection Items

Inspection Point	Inspection Item	Object of Inspection	Correction
Condition	Power Supply Voltage	Within permissible range (2AX: 170 to 253 V, 7AX: 170 to 253 V, 4AX: 323 to 506 V)	Adjust the power supply voltage
	Ambient Temperature	Within permissible range (-10°C to 50°C)	Investigate the cause and adjust to within the specified range
	Ambient Humidity	Within permissible range (20 to 90% RH)	
		Dew condensation or freezing	
Vibration	Within permissible limit (5.9 m/s <sup>2</sup> or less)		
Other	Smell	Smell of burning	Contact the dealer from which the inverter was purchased
	Dust	Accumulation of dust on the cooling fins or cooling fan Accumulation of dust on the control circuit board	Clean Blow with compressed air
	Connectors	Loose connectors	Tighten connectors
	Screws	Loose Screws	Tighten securely

## (2) Periodic Part Replacement

Although the service life will vary according to the environment in which the inverter is installed and the amount of time it is operated, when operated continuously under environmental conditions that are within the allowable ranges, the service life of the electrolytic capacitor is normally approximately 5 years. It is recommended, however, that it be replaced before problems occur.

## (3) Measurement Points and Meters

Because the inverter's input and output voltages and currents contain high frequencies, incorrect selection of the measurement instruments will lead to substantial errors. When using a CT (current detection transformer) to measure the current, if the frequency is low, the size of the error will increase, so use a CT with as large a capacity as possible.

### Measurement Points And Meters

Item		Simple Measurement	Precision Measurement
Input	Voltage	Circuit tester	Moving-iron type voltmeter
	Current	Clamp meter	Moving-iron type ammeter
	Power	—	Electrodynamometer type wattmeter
Output	Voltage	Circuit tester	Rectifier type voltmeter
	Current	Clamp meter	Moving-iron type ammeter
	Power	—	Electrodynamometer type wattmeter

### Example Of Measurement Points And Meters

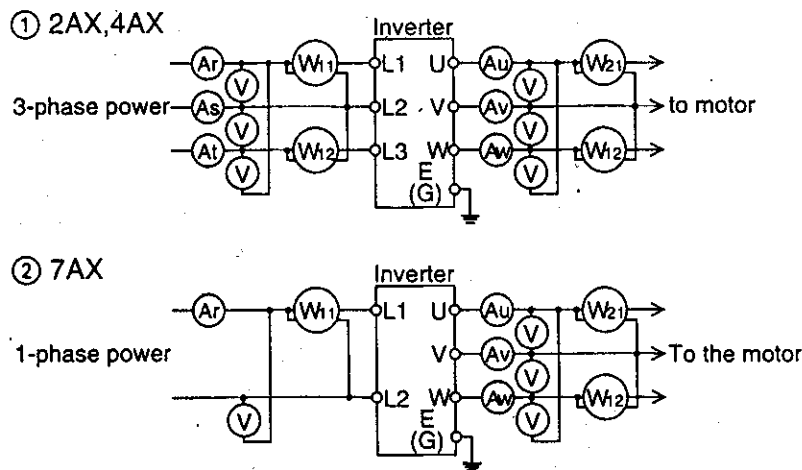

Type of measurement device

↑ Moving-iron type ammeter

↑ Moving-iron type voltmeter

↑ Electrodynamometer type wattmeter

↑ Moving-iron type ammeter

↑ Rectifier type voltmeter

↑ Electrodynamometer type wattmeter

# 11. Troubleshooting

## (1) Protective Function



Protection function	Function Explanation	Display	Protective Operation
Overcurrent protection	Protects the inverter when the current flow momentarily reaches the specified protection level. OC1 : During acceleration OC2 : During deceleration OC3 : During constant-speed operation	OC1 OC2 OC3	<ul style="list-style-type: none"> <li>Stops inverter output.</li> <li>Coast to stop of the motor.</li> <li>Combined alarm (1c) output.</li> <li>Maintains internal alarm signal until alarm reset command is received.*1</li> </ul>
Momentary power failure protection	The inverter may stop if the input voltage falls to AC 165 V or below for 15 ms or longer. If the power failure is shorter than 15 ms, operation will continue. (However, when the restart after momentary power failure function has been selected, operation will automatically be restarted when the power supply is resumed, regardless of how long the duration of the voltage drop. If the LU indication is lit during the power interruption, it will go out when the power supply is resumed. The combined alarm will not be output.)	LU	<ul style="list-style-type: none"> <li>Stops inverter output.</li> <li>Combined alarm (1c) output when power supply is resumed.</li> <li>Maintains internal alarm signal until alarm reset command is received.*1</li> </ul>
Undervoltage protection			
Overvoltage protection	Protects the inverter in the event that an excessive voltage (regenerative overload voltage) as high as the overload voltage protection level occurs.	OU	<ul style="list-style-type: none"> <li>Stops inverter output.</li> <li>Coast to stop of the motor.</li> <li>Combined alarm (1c) output.</li> <li>Alarm signal is held internally until alarm reset command is received.*1 (If the restart after momentary power failure function has been selected, the combined alarm (1c) will not be output.)</li> </ul>
Faulty frequency setting signal	Detects a malfunction in the analog frequency setting circuit (overload of the +10 V power supply for the potentiometer and reverse polarity of the current signal).	OH1	
Inverter overheating	Detects overheating of the inverter caused by an overload, primarily during low-speed operation.		
Inverter overload	Detects the condition where the load exceeds the inverter's rated overload current.		
External alarm	Stops output as an external alarm when a thermal overload relay connected between terminals THR-CM switches from ON to OFF.	OH2	
Electronic thermal overload	When used with a Fuji multipurpose 4-pole motor or 4-pole FV motor, motor overload protection is provided even if there is no external thermostat.	OL1	
Setting error	Displayed when incompatible function codes are selected.	Err1	
Communication error	Displayed when faulty communication between the inverter and the keypad panel occurs continuously.	Err2	
DSP error	Displayed when there is an error in the operation of the internal DSP as a result of external noise interference or an excessively high ambient temperature.	Err3	

(Note 1) Alarm signal hold\*1

When a protection function has been activated and the alarm signal is being output, if the MCCB provided on the power supply side is switched off, the inverter's control power will not be supplied, and the alarm signal will not be held.

(Note 2) Reset command

Press the  key on the keypad panel or turn on the control terminals RST-CM ON to reset the alarm condition.

(Note 3) Information on the last four protection function trips will be stored in memory. After calling up , press the  key to display the information for the first, second and third preceding protection function trips.



(Note 4) The history of past protection function trips can also be displayed by pressing the  key during the display for a current protection function trip.

(Note 5) If the inverter stops with none of the error messages described above being displayed, try switching the power off and then back on.

## (2) Troubleshooting

### ① Procedures for dealing with a protection function display

Display	Check Point	Corrective Measures
OC1	① Power supply voltage within permissible limits ..... ② Output line short-circuited ..... ③ Proper torque boost ..... ④ Proper acceleration time ..... ⑤ Other than ① through ④ above. ....	Adjust the power supply voltage. Check the output cable and the motor's insulation. Adjust to the proper value. Increase the acceleration time. Increase the capacity of the inverter.
OC2	① Power supply voltage within permissible limits ..... ② Output line short-circuited ..... ③ Proper deceleration time ..... ④ Other than ① through ③ above. ....	Adjust the power supply voltage. Check the output cable and the motor's insulation. Increase the deceleration time. Connect a braking resistor (optional). Increase the capacity of the inverter.
OC3	① Power supply voltage within Permissible limits ..... ② Output line short-circuited ..... ③ Sudden change in load ..... ④ Torque boost too high ..... ⑤ Other than ① through ④ above. ....	Adjust the power supply voltage. Check the insulation of the output line and conduct a megger test on the motor. Eliminate sudden changes in the load. Increase the capacity of the inverter. Decrease the torque boost. Investigate for noise intrusion.
OU	① Power supply voltage within permissible limits ..... ② Proper deceleration time ..... ③ Other than ① and ② above. ....	Adjust the power supply voltage. Increase the deceleration time. Connect a braking resistor (optional).
OH1	① Load exceeds the capacity of terminal 13 ..... ② Terminals C1-CM or 12-11 connected in reverse ..... ③ Load is over permissible limits .....	Reduce the load on terminal 13. Connect correctly. Reduce the load.
OH2	① Proper wiring between terminals THR-CM ..... ② Thermal overload relay activated .....	Correct the wiring. Reduce the load.
LU	① Power supply voltage within permissible limits ..... ② MCCB is closed ..... ③ Open phase in the power supply circuit ..... ④ Other than ① through ③ above. ....	Adjust the power supply voltage. Close MCCB. Correct the wiring. Check the power supply capacity.
OL1	① Electronic thermal overload set incorrectly ..... ② Load is over permissible limits ..... ③ Motor is a 4-pole motor .....	Change the electronic terminal overload setting. Reduce the load, or increase the capacity of the motor and the inverter. If there are more or less than 4 poles, add an external thermal overload relay.
Err1	① Correct function code selection .....	Verify function code setting.
Err2	① Noise source close to inverter .....	Noise prevention measures should be considered.
Err3	② Abnormally high ambient temperature .....	Use within the allowable temperature range.

When a protection function is displayed, the motor will coast to a stop. After correcting the cause as described above, press the  key on the keypad panel to reset. (Be sure that the motor is stopped before pressing the  key.) Reset the alarm by switching ON the control circuit terminals RST-CM. When the power is switched on and off, the "LU" display will appear, but this does not indicate a malfunction.

## ② Troubleshooting charts

### i) Motor does not run

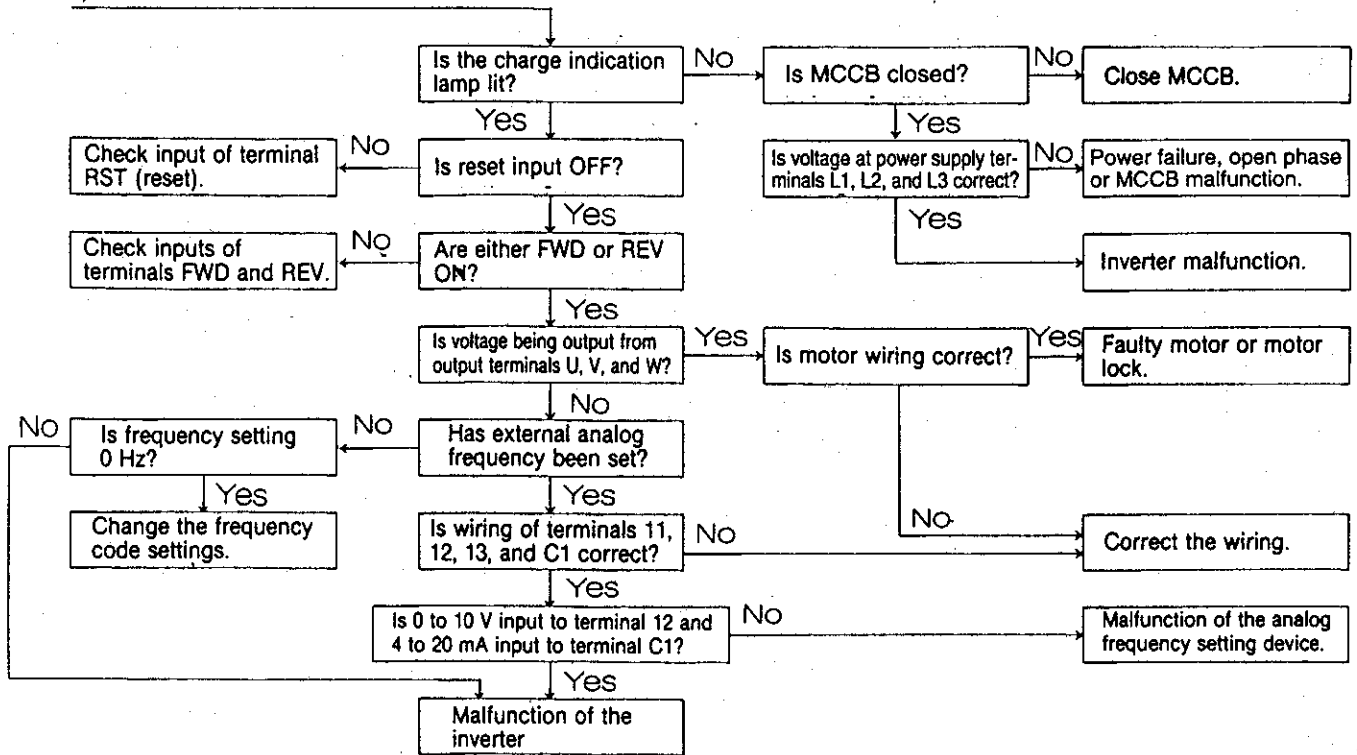

### ii) Motor runs, but speed does not change

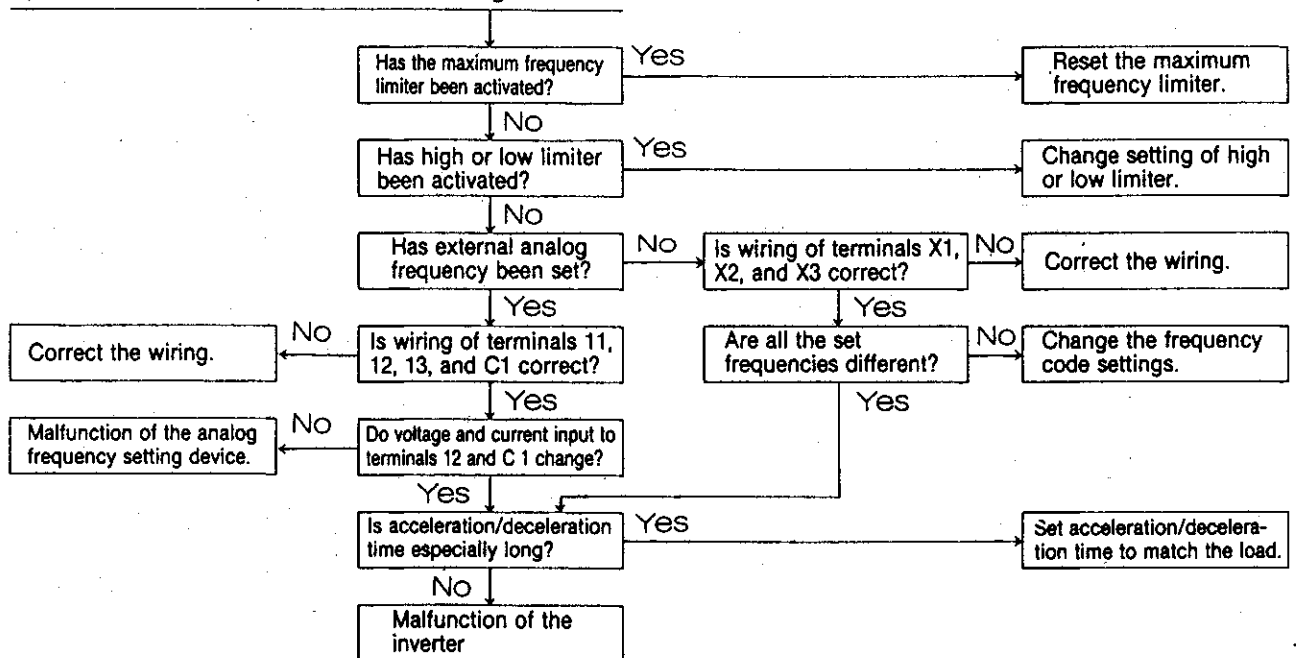

### iii) Motor runs, but not smoothly

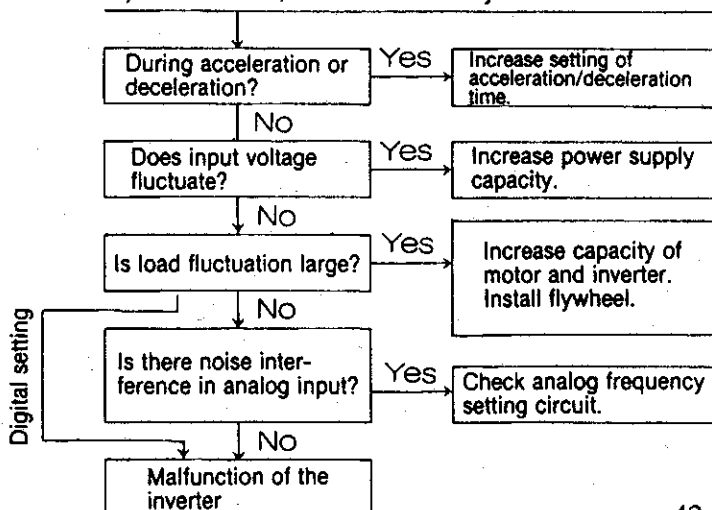

### iv) Motor overheats

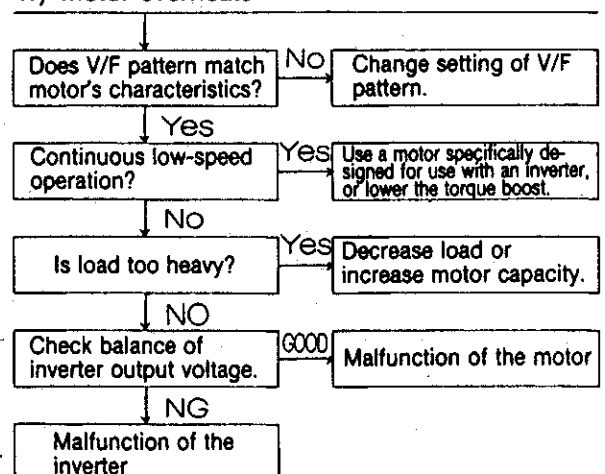

# 12. Appendix

## (1) Standard Specifications

### ① FVR-E7S-2AX

Item	FVR001 E7S-2AX	FVR002 E7S-2AX	FVR004 E7S-2AX	FVR008 E7S-2AX	FVR015 E7S-2AX	FVR022 E7S-2AX	FVR037 E7S-2AX
Applicable motor output [HP]	1/8	1/4	1/2	1	2	3	5
Inverter output at 230 V [kVA]	0.32	0.60	1.2	2.0	3.2	4.4	6.8
Cont. output current [A]	Low carrier frequency	0.8	1.5	3.0	5.0	8.0	11
	High carrier frequency	0.7	1.3	2.5	4.0	7.0	16.5
Input ratings	Power supply	3-phase 3-wire 200 to 230 V 50/60 Hz					
	Allowable variation	Voltage : +10%, -15%    Imbalance in power supply voltage : 3% Frequency : ±5%					
Output ratings	Output Voltage *1	3-phase 3-wire 200 to 230 V					
	Output freq.	50 to 400 Hz					
	Overload capacity	150% for 1 minute, 200% for 0.5s (Inverse time characteristics)					
Braking Torque	Standard *2	100%		70%		40%	
	Option	— *3		150%		100%	

### ② FVR-E7S-7AX

Item	FVR001 E7S-7AX	FVR002 E7S-7AX	FVR004 E7S-7AX	FVR008 E7S-7AX	FVR015 E7S-7AX	FVR022 E7S-7AX	—
Applicable motor output [HP]	1/8	1/4	1/2	1	2	3	—
Inverter output at 230 V [kVA]	0.32	0.60	1.2	2.0	3.2	4.4	—
Cont. output current [A]	Low carrier frequency	0.8	1.5	3.0	5.0	8.0	11
	High carrier frequency	0.7	1.3	2.5	4.0	7.0	10
Input ratings	Power supply	Single-phase 2-wire 200 to 230 V 50/60 Hz					
	Allowable variation	Voltage : ±10% Frequency : ±5%					
Output ratings	Output Voltage *1	3-phase 3-wire 200 to 230 V					
	Output freq.	50 to 400 Hz					
	Overload capacity	150% for 1 minute, 200% for 0.5s (Inverse time characteristics)					
Braking Torque	Standard *2	100%		70%		40%	
	Option	— *3		150%		100%	

### ③ FVR-E7S-4AX

Item	FVR004 E7S-4AX	FVR008 E7S-4AX	FVR015 E7S-4AX	FVR022 E7S-4AX	FVR037 E7S-4AX	
Applicable motor output [HP]	1/2	1	2	3	5	
Inverter output at 460 V [kVA]	1.3	2.0	2.9	4.4	7.2	
Cont. output current [A]	Low carrier frequency	1.6	2.5	3.7	5.5	9.0
	High carrier frequency	1.4	2.1	3.7	5.3	8.7
Input ratings	Power supply	3-phase 3-wire 380 to 460 V 50/60 Hz				
	Allowable variation	Voltage : +10%, -15%    Imbalance in power supply voltage : 3% Frequency : ±5%				
Output ratings	Output Voltage *1	3-phase 3-wire 380 to 460 V				
	Output freq.	50 to 400 Hz				
	Overload capacity	150% for 1 minute, 200% for 0.5s (Inverse time characteristics)			*4	
Braking Torque	Standard *2	70%		40%		
	Option	150%		100%		

Note: \*1 Output voltage cannot exceed the power supply voltage.

\*2 Average torque when the standard 4-pole motor decelerates from 60 Hz to stop.

\*3 Not provided with external resistor terminals.

\*4 150% for 1 minute, 200% for 0.5s in low carrier frequency mode (F12 data code is 0, 1, 2 or 3). 150% for 1 minute in high carrier frequency mode (F12 data code is 4 or 5). (Inverse time characteristics)

④ Common Specifications

Item		Specification
Control	Control system	Sinusoidal PWM control with AVR function
	Frequency control range	0.2 to 400 Hz (minimum frequency adjustable between 0.2 and 15 Hz)
	Output frequency stability	Keypad setting: $\pm 0.01\%$ of maximum frequency ( $-10^{\circ}\text{C}$ to $+50^{\circ}\text{C}$ )
		Analog setting: $\pm 0.2\%$ of maximum frequency (at $25^{\circ}\text{C} \pm 10^{\circ}\text{C}$ )
	Frequency setting resolution	Keypad setting: 0.01 Hz (up to 9.99 Hz), 0.1 Hz (10 to 99.9 Hz), 1 Hz (100 Hz and over)
		Analog setting: 0.02 Hz step (at maximum frequency 60 Hz)
	Voltage/frequency characteristic	200 V series Volt.: 200 to 230 V, Freq.: 0 to 400 Hz
		400 V series Volt.: 380 to 460 V, Freq.: 0 to 400 Hz
	Torque boost	32 modes selectable (variable torque mode selectable)
	Accel./decel. characteristic	0.01 to 3600s (Independently adjustable accel. and decel. ) (Alternative acc/dec time available)
DC braking	Starting freq.: 0.2 to 60 Hz, Operating time: 0.01 to 30s, Voltage: 16 notches	
Standard function	Current limiting, Restart after momentary power failure, Multistep seep setting (7 step), High and low limiter, Bias frequency, Carrier frequency selection	
Protection		Stall prevention, Overcurrent, Overvoltage, Undervoltage, Momentary power failure, Inverter overload, Inverter overheating, Motor overload (Electronic thermal OL relay trip), External fault (External thermal OL relay trip), DSP error
Operation	Frequency setting input	Frequency setting potentiometer, Voltage input: 0 to +10 V DC (0 to +5 V DC) (Gain adjustable between and 200%) Current input: 4 to 20 mA DC
	Input signal	Forward command, Reverse command, Multistep speed selection, Alternative acc/dec time selection, External fault, Alarm reset, coast-to-stop command
	External output signal	Relay output Alarm (SPDT, 250 V AC, 0.3A, $\cos=0.3$ )
		Open collector output Inverter running
Indication	Frequency meter output signal	Analog: 0 to +10 DC (Adjustable between 6.5 to 10.3 V) Pulse: 1440 Hz/Maximum frequency
Keypad panel	Running	Output frequency, Reference frequency, Output current, Output voltage, Motor synchronous speed, Machine speed
	Setting	Function code and data code
	Fault	Overcurrent during acceleration (OC1), Overcurrent during deceleration (OC2), Overcurrent during running at constant speed (OC3), Overvoltage (OU), Undervoltage (LU), Inverter overload/overheating (OH1), Motor overload (Electronic thermal OL relay trip) (OL1), External fault (OH2), Setting error (Err1), DSP error (Err3), Fault memory (Immediately previous 4 faults)
Charge lamp		DC intermediate circuit voltage
Conditions	Installation location	Indoor, not more than 1000 m above sea level. Do not install in a dusty location or expose to corrosive grases or direct sunlight
	Ambient temp humidity	$-10^{\circ}\text{C}$ to $+50^{\circ}\text{C}$ (Remove the cover to allow use at $+40^{\circ}\text{C}$ to $+50^{\circ}\text{C}$ ) 20 to 90% RH (Non-condensing)
	Vibration	$5.9 \text{ m/s}^2$ (0.6 G) or less (Conforming to JIS C0911)
	Storage temp.	$-25^{\circ}\text{C}$ to $+65^{\circ}\text{C}$
	Degree of protection	IP40 enclosure (cooling fan: IP20)
Installation method		Inside switchboard, External cooling

(2) External Dimension

① Inverter Cabinet

Model		001	002	004	008	015	022	037
2AX	Front view	Fig. 1	Fig. 1	Fig. 1	Fig. 5	Fig. 5	Fig. 8	Fig. 8
	Side view	Fig. 2	Fig. 3	Fig. 4	Fig. 6	Fig. 7	Fig. 9	Fig. 10
7AX	Front view	Fig. 1	Fig. 1	Fig. 5	Fig. 5	Fig. 8	Fig. 8	-
	Side view	Fig. 2	Fig. 3	Fig. 6	Fig. 7	Fig. 9	Fig. 9	-
4AX	Front view	-	-	Fig. 5	Fig. 5	Fig. 8	Fig. 8	Fig. 8
	Side view	-	-	Fig. 7	Fig. 7	Fig. 9	Fig. 9	Fig. 10

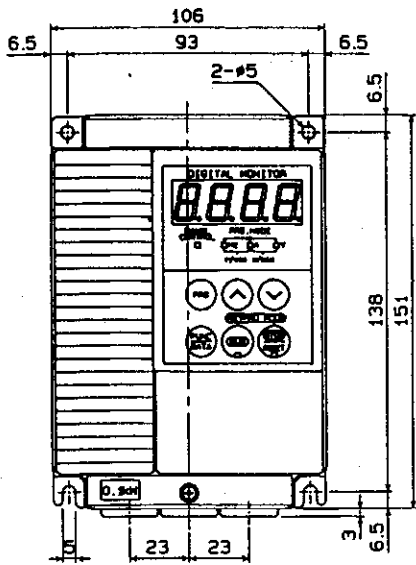

Fig. 1

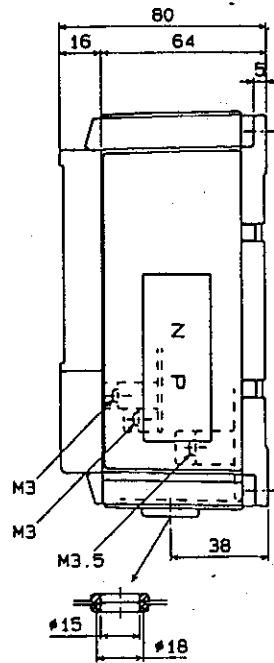

Fig. 2

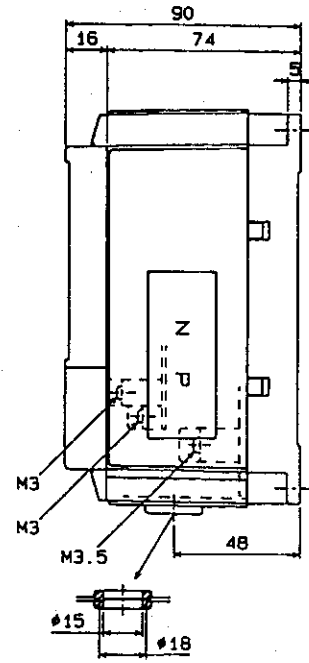

Fig. 3

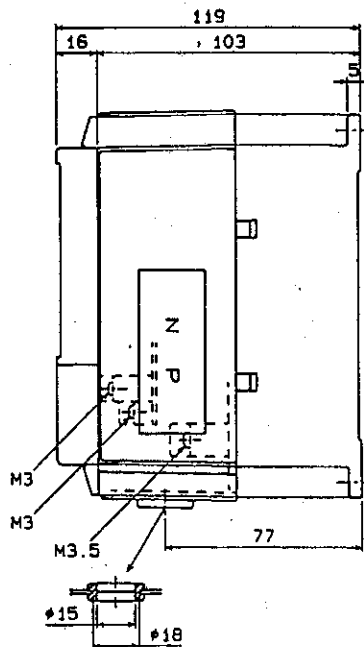

Fig. 4

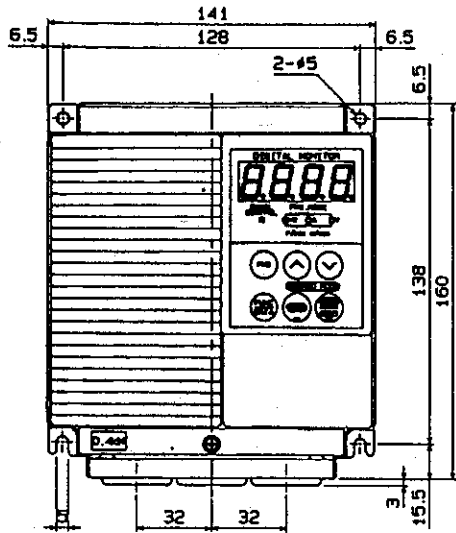

Fig. 5

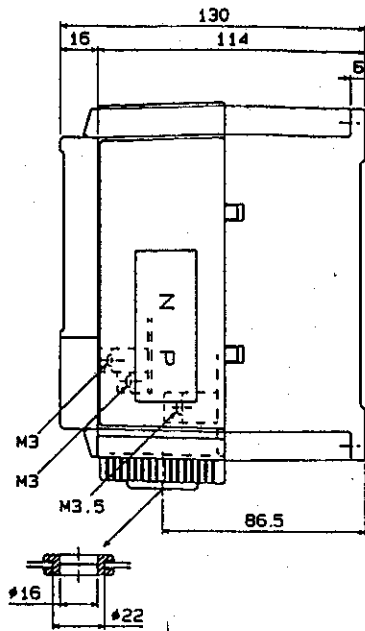

Fig. 6

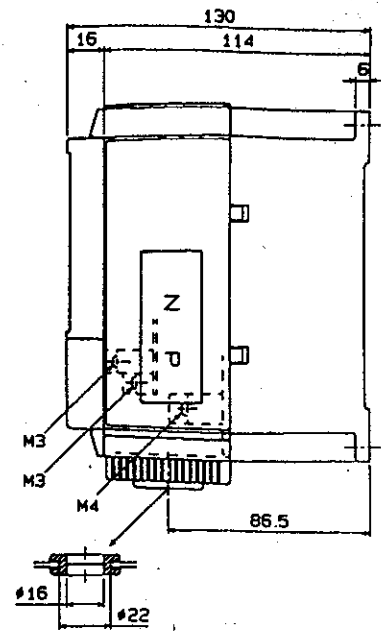

Fig. 7

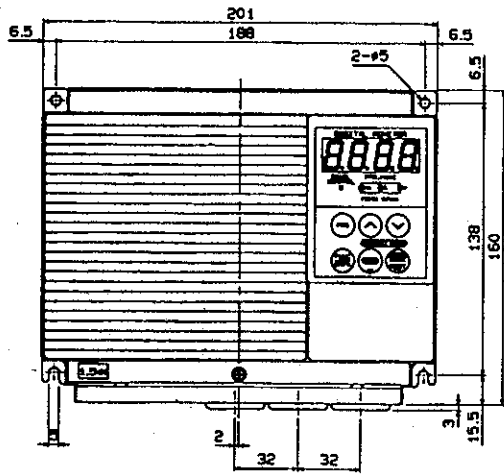

Fig. 8

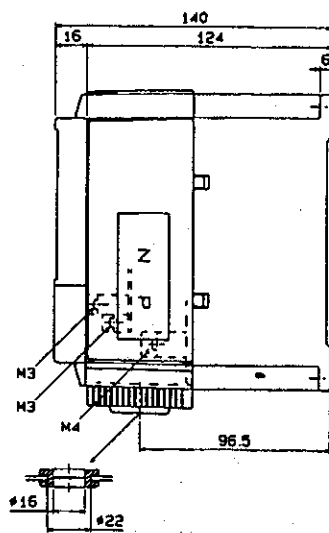

Fig. 9

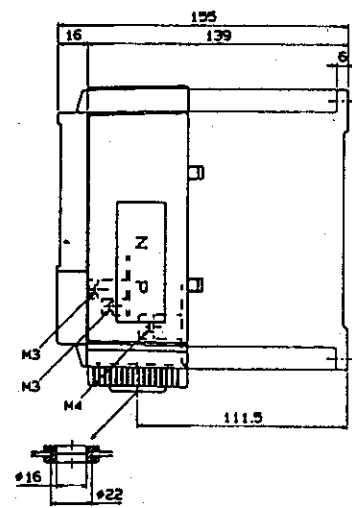
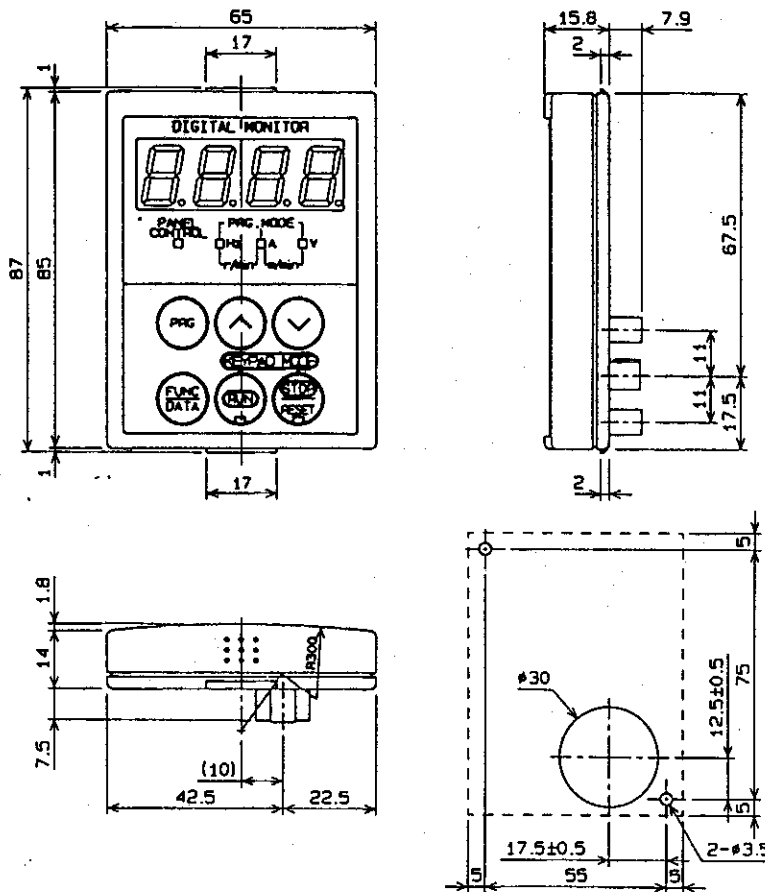

Fig. 10

## ② Keypad Panel



Dimensions for cutting  
of the keypad panel mounting holes

## (3) Application Of Wiring And Equipment

Motor output [HP]		1/8	1/4	1/2	1	2	3	5	
Inverter type		001	002	004	008	015	022	037	
Applicable wire size [mm]	2AX	L1, L2, L3		3.5			5.5		
		U, V, W		3.5			5.5		
	7AX	L1, L2		3.5			5.5		
		U, V, W		3.5			5.5		
	4AX	L1, L2, L3		-			3.5		-
		U, V, W		-			3.5		-
		(+), DB		-			3.5		-
GND (PE)		-			2.0			-	
Control circuit		-			1.25			-	
Fuji MCCB	2AX	SA33B/15			SA33B/20		SA53B/30		
	7AX	SA32B/30			SA52B/40		-		
	4AX	-		SA33B/5	SA33B/10	SA33B/15			
Fuji ELCB	2AX	SG33B/15			SG33B/20		SG53B/30		
	7AX	SG32B/30			SG52B/40		-		
	4AX	-		SG33B/5	SG33B/10	SG33B/15			
Fuse [A]**	2AX	5 (20A <sup>2</sup> s)		5 (70A <sup>2</sup> s)	10 (120A <sup>2</sup> s)	20		30	
	7AX	20 (70A <sup>2</sup> s)	20 (120A <sup>2</sup> s)	20 (150A <sup>2</sup> s)	20	30	40	-	
	4AX	-		5		10		20	
Fuji magnetic contactor	2AX	SC-1N			SC-05		SC-5-1		
	7AX	SC-1N			SC-05	SC-5-1	SC-1N		
	4AX	-		SC-05					
Fuji thermal relay	2AX	TR-1SN (0.95 - 1.45)		TR-1SN (1.7 - 2.6)	TR-1SN (2.8 - 4.2)	TR-1SN (5 - 8)	TR-1SN (7 - 11)	TR-1SN (12 - 18)	
	7AX	TR-1SN (0.95 - 1.45)		TR-1SN (1.7 - 2.6)	TR-1SN (2.8 - 4.2)	TR-1SN (5 - 8)	TR-1SN (7 - 11)	TR-1SN (12 - 18)	
	4AX	-		TR-1SN (0.95 - 1.45)	TR-1SN (1.4 - 2.2)	TR-1SN (2.8 - 4.2)	TR-1SN (4 - 6)	TR-1SN (6 - 9)	
Spark killer		S2-A-0 (for magnetic contactor), S1-B-0 (for mini control relay and timer)							

Notes: 1. The above tables are based on Fuji standard motors.

2. Wire size are based on 600 V voltage 1 V wire.

\*1 ( ) minimum I<sup>2</sup>t values.

#### (4) Terminal Function

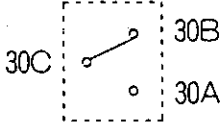
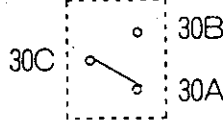
	Terminal Code	Terminal Name	Explanation
Main circuit	L1, L2, L3	3 $\Phi$ commercial power supply input terminal	Connection for commercial power supply AC 200 to 230 V or AC 380 to 460 V.
	L1, L2	1 $\Phi$ commercial power supply input terminal	Connection for commercial power supply AC 200 to 230 V.
	U, V, W	Inverter output terminals	For connection of a 3-phase induction motor.
	P (+), DB	External braking resistor terminals	For connection of an external braking resistor (400 W or higher).
	E (G)	Ground	For connection of the ground wire.
Control input terminals	11	Frequency setting common terminal	Reference electric potential for voltage setting and current setting.
	12	Frequency setting voltage input	When DC 0 to 10 V (0 to 5 V) is input, the maximum frequency is reached at +10 V (5 V) and it remains proportional to the voltage down to 0 V. Input resistance is 22 k $\Omega$ . (The 5 V level is for when the frequency setting gain is set to 200%.)
	13	Power supply for frequency setting	Stabilized power supply of DC+10 V, 10 mA or less (for terminal 11).
	C1	Frequency setting current input (+)	When DC 4 to 20 mA is input, the maximum frequency is reached at 20 mA and it remains proportional to the current down to 4 mA.
	CM	Control circuit common terminal	Reference electric potential for the control input/output signals.
	FWD REV	Forward command input terminal Reverse command input terminal	Forward command when FWD-CM is closed and reverse command when REV-CM is closed. (Inverter decelerates and stops when FWD-CM and REV-CM are both closed.)
	X1 X2 X3	Multistep speed selection terminal 1 Multistep speed selection terminal 2 Multistep speed selection terminal 3	Examples: Multistep speed 1 when X1-CM is closed. Multistep speed 2 when X2-CM is closed. Multistep speed 7 when X1-X2-X3-CM is closed. (When there is no input to X1, X2, or X3, operation will be at the frequency set via the keypad panel or via the analog signal.)
	RT1	Acceleration/deceleration time 2 selection terminal	Acceleration/deceleration time 2 is selected when RT1-CM is closed. Note: When there is no input to RT1, operation will be at acceleration or deceleration time 1.
	THR	External alarm terminal	Motor will coast-to-stop when THR-CM is opened. (If there is no external alarm, the inverter cannot be operated unless THR-CM is short-circuited.)
	RST/BX	Reset/Motor coast-to-stop input terminals	When a trip occurs, the protection function is reset by short-circuiting RST-CM (closed) for 0.1 s or longer. (If there is input to FWD or REV, operation is restarted simultaneous with the reset.) If BX-CM is closed during operation, a free-run stop will occur. (Used when applying a mechanical brake.)
Control output terminals	FMa	Analog frequency meter terminal	Outputs +10 V at the maximum frequency, and remains proportional to the output frequency down to 0 V. DC voltmeter (7 to 10 V): Internal resistance of 10 k $\Omega$ or greater. DC ammeter (1 mA): Adds 10 k $\Omega$ 1/2 W in series.
	FMb	Digital frequency meter terminal	Outputs 1440 Hz at the maximum frequency, and remains proportional to the output frequency down to 0 Hz. (Pulse voltage: Peak 5 v, 50% duty)
	RUN	Operation-in-progress signal terminal	Switches on RUN-CM when the inverter's output frequency is 1 Hz or higher. (Open collector output, DC 27 V, 20 mA or less)
	30A 30B 30C	Combined alarm terminals	Output via contact 1c to indicate that the inverter's protection function has been activated. (Contact capacity AC 250 V, 0.3 A, $\cos\phi = 0.3$ )  <div style="display: flex; justify-content: space-around; align-items: center;"> <div style="text-align: center;">  <p>(Normal)</p> </div> <div style="text-align: center;">  <p>(During trip)</p> </div> </div>
	NC	Unused terminal	Do not connect anything to this terminal.

(5) Control Block Diagram

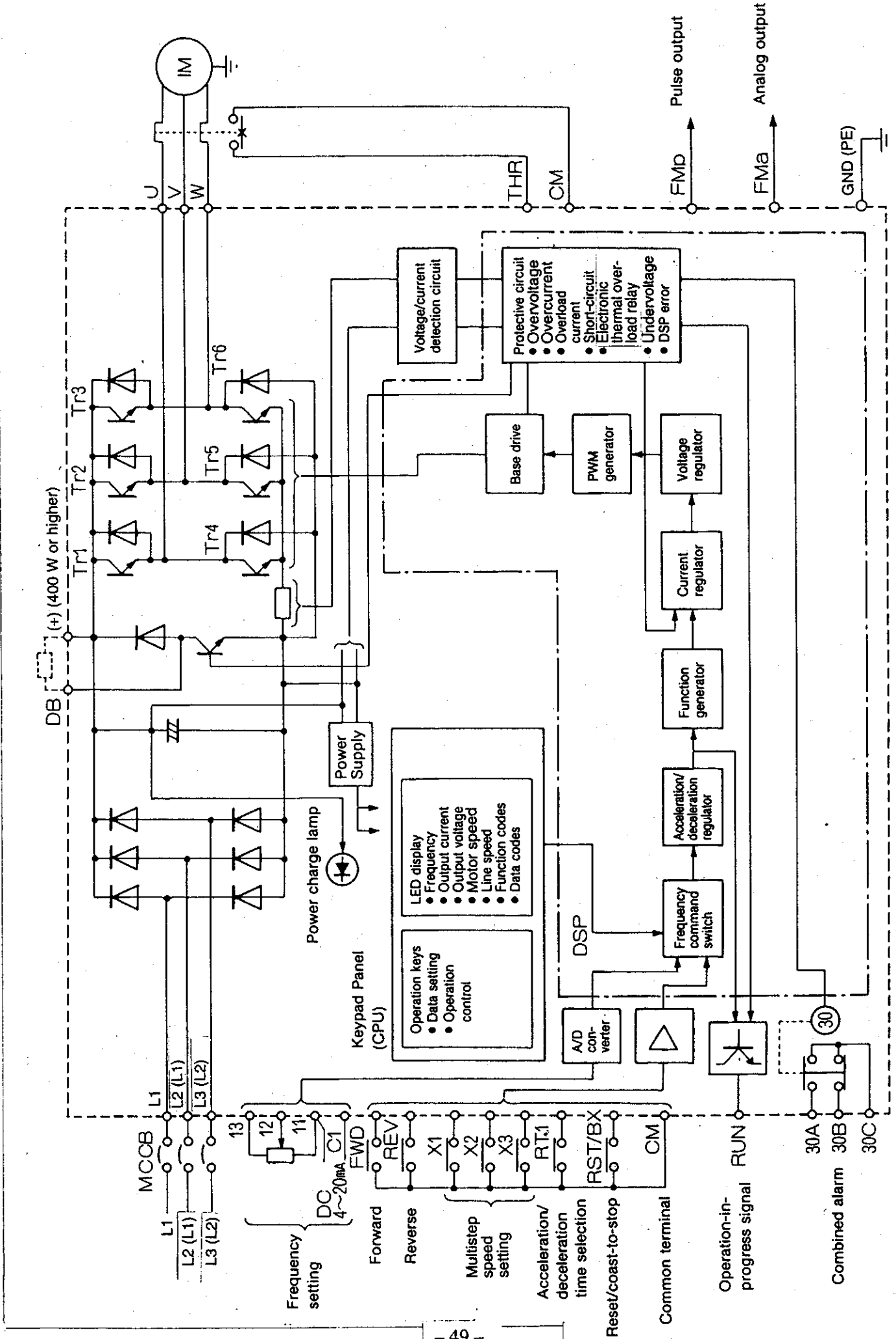

## Function Code Table

Function code	Function	Data code, range	Factory setting	Function code	Function	Data code, range	Factory setting
F 00	Data protection	0 : Data change possible 1 : Data change not possible	0	F 20	DC braking time	0.01 ~ 30s	0.10
F 01	Frequency command	0 : Keypad panel setting 1 : Analog setting (voltage + current)	0	F 21	Multistep speed setting 1	0.00 ~ 400 Hz	10.00
F 02	Operation command	0 : Keypad panel operation 1 : Terminal operation	0	F 22	Multistep speed setting 2		20.00
F 03	Maximum frequency	0 ~ 400 Hz	60	F 23	Multistep speed setting 3		30.00
F 04	Base frequency	0 ~ 400 Hz	60	F 24	Multistep speed setting 4		40.00
F 05	Maximum output voltage	0 : Output voltage is proportional to the power supply voltage. 1 to 240V, 2 to 460V : AVR	230 460	F 25	Multistep speed setting 5		50.00
F 06	Acceleration time 1	0.01 ~ 3600s	6.00	F 26	Multistep speed setting 6		60.00
F 07	Deceleration time 1	0.01 ~ 3600s	6.00	F 27	Multistep speed setting 7		60.00
F 08	Torque boost	0 ~ 31 (code)	13	F 28	Frequency meter output	0 : Analog output (FMa) 1 : Pulse output (FMa)	0
F 09	FMA terminal output level calibration	0 ~ 99 (code)	85	F 29	Fault memory	The last four fault statues are displayed sequentially.	—
F 10	Number of motor poles	2 : 2 poles 8 : 8 poles 4 : 4 poles 10 : 10 poles 6 : 6 poles 12 : 12 poles	4	F 30	Starting frequency	0 ~ 15 Hz	1
F 11	Line speed display coefficient	0.01 ~ 200	0.01	F 31	Operating mode of current limiting	0 : Inactive 1 : Active (Mode 1) 2 : Active (Mode 2)	0
F 12	Motor running sound	0 ~ 5 (code)	3	F 32	Current limiting level	30 ~ 150%	150
F 13	Acceleration/deceleration time 2	0.01 ~ 3600s	10.00	F 33	Response time for current limiting mode 2	0 ~ 99 (code)	0
F 14	Restart after momentary power failure	0 : Inactive 1 : Active	0	F 34	Bias frequency	0 ~ 100%	0
F 15	Electronic thermal overload relay	0 : Inactive 1 : Active (for standard motor) 2 : Active (for FV motor)	0	F 35	Gain for frequency setting signal	0 ~ 200%	100
F 16	Electronic thermal overload relay level	30 ~ 105%	90	F 36	High limiter	0 ~ 100%	100
F 17	DC brake	0 : Inactive 1 : Active	0	F 37	Low limiter	0 ~ 100%	0
F 18	DC brake starting frequency	0 ~ 60 Hz	0	F 38	Motor characteristics	0 ~ 10	5
F 19	DC brake voltage	0 ~ 15 (code)	0	F 39	Data initialization	0 : Inactive 1 : Active	0

(Note) During operation, function code data 06 to 13, 21 to 27, 29, 35 and 38 is possible. Also, all function codes and data verification is possible.