

Sine Wave Modulating Type Transistor Inverter

**NEW**

**FRENIC<sup>®</sup> 5000G**

**OPERATION MANUAL**

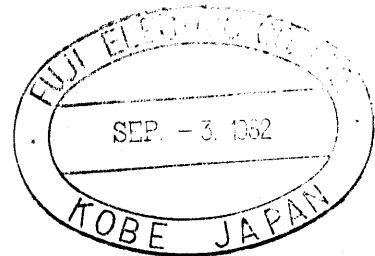

## CONTENTS

1.	General .....	1
	1-1 Introduction .....	1
	1-2 Checking at Acceptance .....	1
	1-3 Installation .....	1
	1-4 Standard Specification .....	3
2.	Construction and Wiring .....	5
	2-1 Construction of Control Unit .....	5
	2-2 Wiring Connection .....	6
	2-3 Table of Input/Output Terminals .....	10
	2-4 Terminals Arrangement and Connector's Terminals Arrangement .....	12
	2-5 Table of Main Circuit Equipments and Wire Application .....	13
	2-6 Dynamic Braking Unit (Option) .....	14
3.	Trial Run .....	17
	3-1 Preparation for Operation .....	17
	3-2 Trial Run .....	17
4.	Adjustment and Checking .....	20
	4-1 Preparation of Meters .....	20
	4-2 Adjusting Procedure .....	21
	4-3 List of Checking Terminals .....	25
5.	Maintenance .....	27
	5-1 Daily Maintenance .....	27
	5-2 Fault Diagnosis .....	28
	5-3 Table of Fault Diagnosis .....	29

## 1. General

### 1-1 Introduction

FRENIC 5000G requires to be handled properly to exhibit its performance most successfully.

You are therefore requested to peruse this manual before you are using the device.

### 1-2 Checking at Acceptance

Upon reaching of this device to your place, affirm the following items:

- (1) Specifications and accessories exactly meet with your order.
- (2) The device has not been inflicted with any damage during transportation.
- (3) Every screw, nut and connector, etc. are not loosened.

Note: [1] The device should be handled cautiously lest be damaged during unpacking and carriage.

[2] In the case of a long-term storage of this device, store it leaving intact with the packing under clean and dry environment in suitable temperature prevented from direct sunshine.

### 1-3 Installation

As adequacy of installation has much effect on the life of equipment, take care of the following items:

- (1) The place in high temperature, high humidity or under frequent vibration must be avoided for the installation.

- (2) Dusty or oily area, as well as places containing corrosive gas and the like, must also be avoided.
- (3) The unit should be mounted vertically.
- (4) As this device is a heat-generating member, it should be prevented from being stored in a compact sealed casing or where mass of parts and heat-generating items, etc. are around the device, with rise of temperature inside the panel taking into account. And also it should be recommended that some spaces shall be maintained on upper, lower and both sides of the device for installation, as shown in the figure given below. (Specially the right side requires a space of 15cm or more to enable opening of the control printed board.)

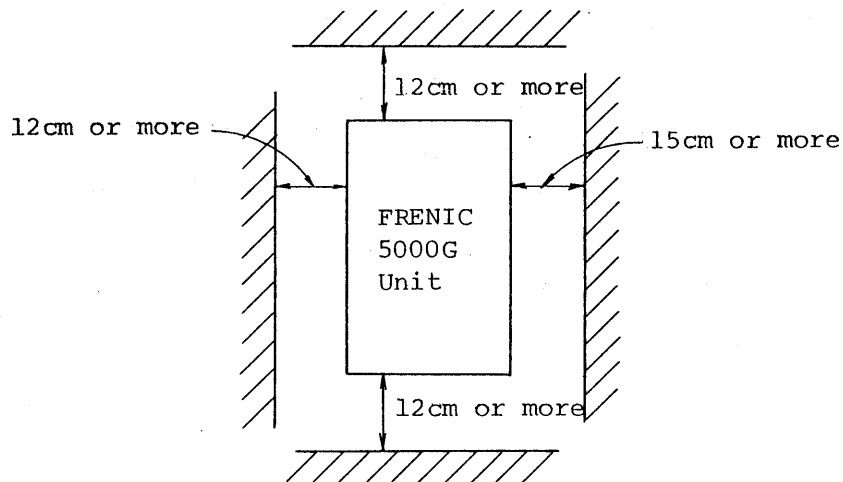

Standard Specification for FRENIC 5000G

ITEM	INDIVIDUAL SPECIFICATION							
	RKNNG 809-2	RKNNG 110-2	RKNNG 150-2	RKKNNG 200-2	RKKNNG 300-2	RKKNNG 400-2	RKKNNG 500-2	RKNNG 600-2
Unit Type								
Output of applied motor [kW]	5.5	7.5	11	15	22	30	37	45
Capacity of inverter [kVA]	8	11	15	20	30	40	50	60
Rated output current [A]	23	32	44	57	86	115	143	173
Weight of unit [kg]	19	26	36	36	55	70	87	115
Unit generating thermal loss [kW]	0.3	0.4	0.55	0.75	1.1	1.5	1.9	2.3

ITEM		COMMON SPECIFICATIONS
Electricity source	Input power voltage	AC 200/220V
	Frequency, No. of phases	50/60 Hz, 3 $\phi$
	Allowable volt. fluctuation	-10% ~ +15%
	Allowable freq. fluctuation	$\pm$ 5%
	Rated power capacity	Applied motor output x 1.5
Environment	Place of application	Installed in indoor panel
	Above sea level	1000 m or less
	Environmental temperature	-10 ~ +40°C (Temperature around the unit is, however, to be +50°C or less.)
	Humidity	Relative humidity 90% or less (To be no dewing).

	ITEM	COMMON SPECIFICATION
Control specifications	Rated output voltage	3-phase, 3 wires type 200V (under input: 220V $\pm$ 10%). [Note: For 200V of input voltage, output voltage may fluctuate due to power fluctuation.]
	Rated output frequency	50 Hz, 60 Hz, 100 Hz, 120 Hz. (Changeover with the switch [FRE].) *
	Control system	Sine wave PWN control
	Frequency control range	1:20 (Constant output range 1:2, Constant torque characteristic 1:10) (Max. frequency is adjusted up to +5%)
	Accuracy of frequency	$\pm$ 0.5% of max. frequency (at 25°C $\pm$ 10°C)
	V/F ratio	Change-over of V/F in "Constant", "Higher" and "Const. output" (with switch [TORQUE]).
	Anti-overcurrent capacity	150% per 1 min.
	Soft start/stop time	Change-over in 2~20, 20~200 sec. (Independently adjustable for both times of start and stop.)
	Operation system	Reversible operation
	Efficiency of converter	95% or more
	Speed setting signal	DC 0 ~ -10V (input resistance 10K ohms) [with minimum speed limiter]
	Protective function	Current limitation, overvoltage suppression, overcurrent tripping, overvoltage tripping, inverter overload, stall prevention, cooling fin overheat, fuse failure, thermal trip input terminal, dynamic brake resistance overheat contact input terminal.
	Faults alarm	Individual indication of faults. (Lamp lights in fault).  Overcurrent trip (OC) Overvoltage trip (OV) Inverter overload: To trip for 1 min. at 150% overcurrent (OL)  Fuse failure (OC) Cooling fin overheat (HT) Motor thermal relay operates (MOL) Dynamic brake resistance overheat (RT)  Faults alarm relay 30 (1C contact) operates by any one of above actions.
Unit specifications	Painting color	Mancel No. NI. 2, semi-glossy
	Wiring	Bar, IV cable, VSF cable
	Cable color	Main circuit : Black Control circuit : Yellow Base circuit : Red, white, blue Earthing line : Green
	Terminals process	Round pressed adhesion, soldering.
	Cooling mode	Air cooling

\* See page 24 for selecting method of V/f pattern.

## 2. Composition and Wiring

### 2-1 Composition of control unit

Names of each part of the control unit are shown as follows:

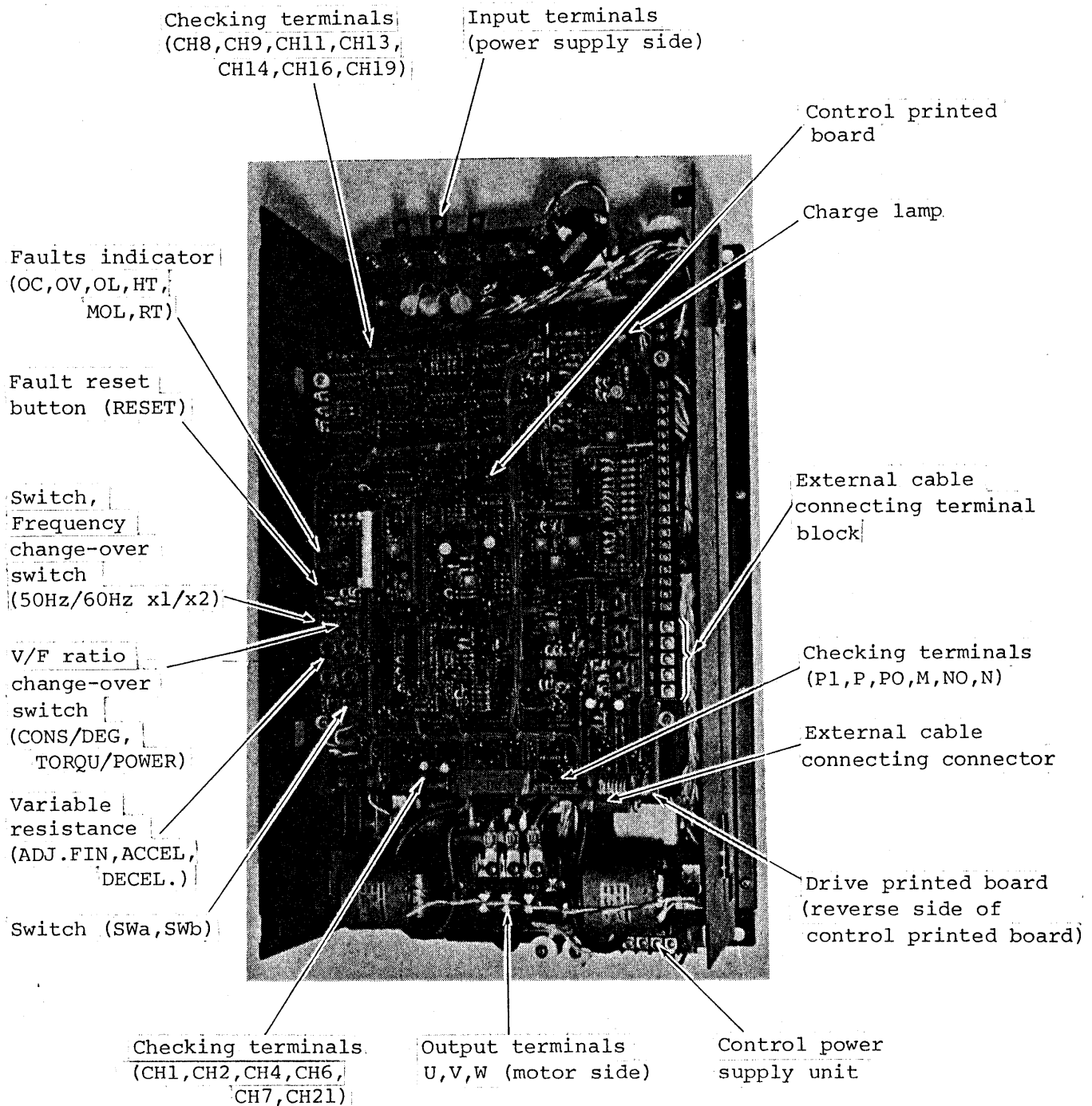

## 2-2 Wire Connection

Wiring is to be made correctly referring to the diagram given in the next page, and care must be taken for the following points.

- (1) Working power supplying equipments (MCCB, MC, etc.), sequence RY, frequency adjuster and frequency meter, etc. are to be employed of our recommending brand or equivalence.
- (2) In case using ELB (Earth Leake Breaker), employ of the impulsive wave non-reactive type and in the moderate sensitive type [our example of SG series and EG-A series (used for inverter)]. If the one not having impulsive wave non-reactive performance or in high sensitive type (15mA~100mA) is used, there is possible occurrence of erroneous operation of ELB according to the main circuit wiring.
- (3) In order to prevent noise, connect in parallel the CR filters (in case of A.C. operating circuit) or the reverse parallel diodes (in case of D.C. operating circuit) to coils for MC (magnetic contactor) and RY. Wiring example is shown in page 8.

### a) Application of CR filters and diodes (Circuit voltage: 250V or less)

Objective equipment		CR filter or diode
Magnetic contactor (Main circuit)	AC	S2-A or equivalence
	DC	Diode or S2-A
Aux. relay	AC	S1-B or equivalence
	DC	Diode or S1-B
Fluorescent lamp		S1-B
Solenoid Brake Clutch	AC	S2-A
	DC	Diode

3#  
200/220V  
50/60Hz

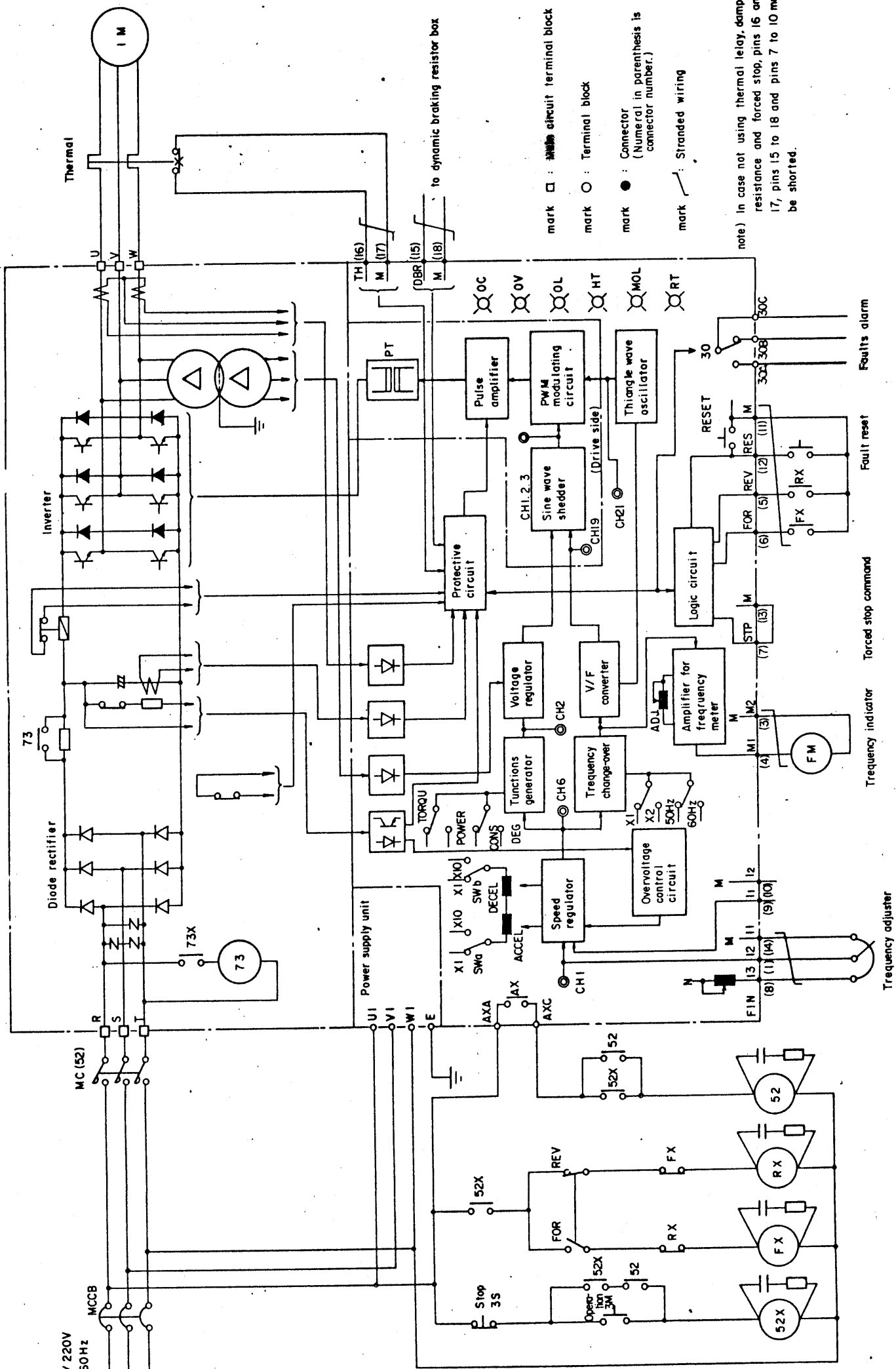

- mark □ : ~~Wiring~~ circuit terminal block
- mark ○ : Terminal block
- mark ● : Connector (Numerical in parenthesis is connector number.)
- mark / : Stranded wiring

(note) In case not using thermal relay, damping resistance and forced stop, pins 16 and 17, pins 15 to 18 and pins 7 to 10 must be shorted.

Standard wiring Diagram

① Capacity of CR filter

S2-A C : 0.2 $\mu$ F 500VDC  
(Made by Nippon Tsushin Kogyo)

R : 500 ohms

S1-B C : 0.1 $\mu$ F 500VDC  
(Made by Nippon Tsushin Kogyo)

R : 200 ohms

② Capacity of diode

(for 1A or less of operating coil current)

ERB24-06C 600V 1A  
(Surge: 45A/10mS)

b) Wiring Example

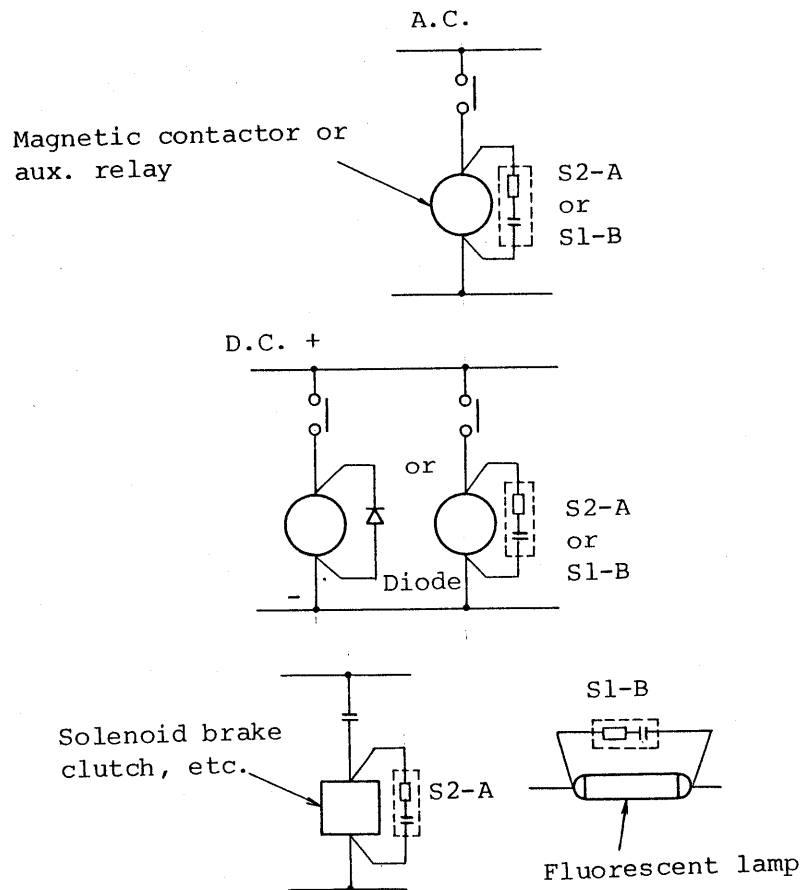

CR filters and diodes for against spark are to be connected directly to spark shedding portion and wirings must be made as short as possible.

- (4) For capacity of power supply and cables for power circuit, use respectively of suitable to capacity of the inverter and loading motor output. (See 2-5 "Table of main circuit equipments and applicable cables".)
- (5) Stranded wire or shield wire is to be used for wiring to the frequency adjuster circuit and the frequency indicator, and to be separated as far as possible from the power circuit to prevent from being incorporated into the same duct.
- (6) Connect wiring for the motor circuit, with turning direction affirming. (Even if the order of phase in the inverter input side is interchanged, turning direction of the motor can not be changed.)
- (7) The device (including the motor) must be provided with earthing to prevent electric shock. Other parts than this and terminals, etc. should never be earthed.
- (8) Insertion of a surge killer, etc. between output terminals of the inverter may result in some disorder. Avoid any insertion as which is not needed specially.
- (9) Provision of a phase advancing condenser on output terminal (loading side) of the inverter is never permitted.
- (10) Upon completion of wiring, check on that the wiring has been correctly accomplished. Thorough care must be taken to that any erroneous wiring has possibility causing not only a faulty operation but damage to the equipment.  
(Do never make error in connection of the power supply input terminals R, S and T and the motor output terminals U, V and W.).

2-3 Table of Input/Output Terminals

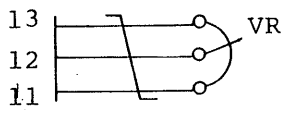
No.	Symbol	Use	Description	Remarks
TB1	R	3-phase AC power input	3 $\phi$ , 200/220V, 50/60Hz. Order of phase needs not to be matched specially.	See page 12 for terminals of power circuit.
	S			
	T			
	U	VVVF inverter output terminals	3 $\phi$ , 2.5~50Hz 5~100Hz Approx. 20V~200V 3~60Hz 6~120Hz Connect them in accordance with phase order of the motor.	
	V			
W				
TB2	U1	Power for control circuit	3 $\phi$ , 200/220V, 50/60 Hz Phase order needs not to be matched specially.	
	V1			
	W1			
	E	Earthing terminal	Connect to earthing bus.	
	13(8)	Frequency adjuster input	 VR: 1k ohm Input impedance: 10k ohms	Figure in ( ) is connector pin No.
	12(1)			
	11(14)			
CN1	11(9)	Aux. input	0~-10V DC (input impedance 10 k ohms) (0V input added to frequency adjustment is, however, even to be 5%.)	{ Frequency indicator outputs at 60Hz/100% for 50/60Hz selection, and at 120Hz/100% for 100Hz/120Hz selection.
	12(10)			
	M1(4)	Frequency indicator	Connect with 10V/100% 1mA meter. (Take care to max. frequency scale.)	
	M2(3)			
	FOR(6)	Operation command	<ul style="list-style-type: none"> <li>. Normal operation is set with FOR-M contact.</li> <li>. Reverse operation is set with REV-M contact.</li> <li>. Put both FOR and REV open for stop.</li> <li>. Fault reset is able by RES-M contact.</li> <li>. (However, reset is unable if frequency command is issued.)</li> <li>. Contacts capacity is to be 24VDC 5mA or more.</li> </ul>	
	REV(5)			
	RES(12)			
	M(11)			
STP(7)	Forced stop of inverter	<ul style="list-style-type: none"> <li>. Inverter is forcibly stopped at STP-M opening.</li> <li>. Make short circuit between STP-M if unused.</li> <li>. Contacts capacity is to be 24VDC 5mA or more.</li> </ul>		
M(13)				

No.	Symbol	Use	Description	Remarks
CN1	TH(16)	Thermal relay connection	<ul style="list-style-type: none"> <li>. Connect the contacts being opened at operation of thermal relay.</li> <li>. Make short circuit between TH-M if unconnected.</li> <li>. Contacts capacity is to be 24VDC 5mA or more.</li> </ul>	
	M(17)			
	DBR(15)	Brake resistance overheat	<ul style="list-style-type: none"> <li>. This is a contact input opened at brake resistance overheat.</li> <li>. Makes short circuit with these contacts if brake circuit is unused.</li> <li>. Contacts capacity is to be 24VDC 5mA or more.</li> </ul>	
	M(18)			
TB3	AXA	Operation signal	<ul style="list-style-type: none"> <li>. Dry contact output contact capacity is to be AC250V, 7.5A or over.</li> <li>. To be in contact by operation command.</li> <li>. To be opened when frequency of inverter falls into zero after given stop command.</li> <li>. To be opened at tripping of 0V and 0C as inverter fails, and at zero of frequency for occurrence of OL, HT and MOL.</li> </ul>	
	AXC			
	30A	Fault signal	<ul style="list-style-type: none"> <li>. Coil is excited in fault.</li> <li>30A-30C contact</li> <li>30B-30C open</li> <li>. Contacts capacity is to be AC 250V, 7.5A</li> </ul>	
	30B			
	30C			

## 2-4 Terminals Arrangement and Connector's Terminals Arrangement

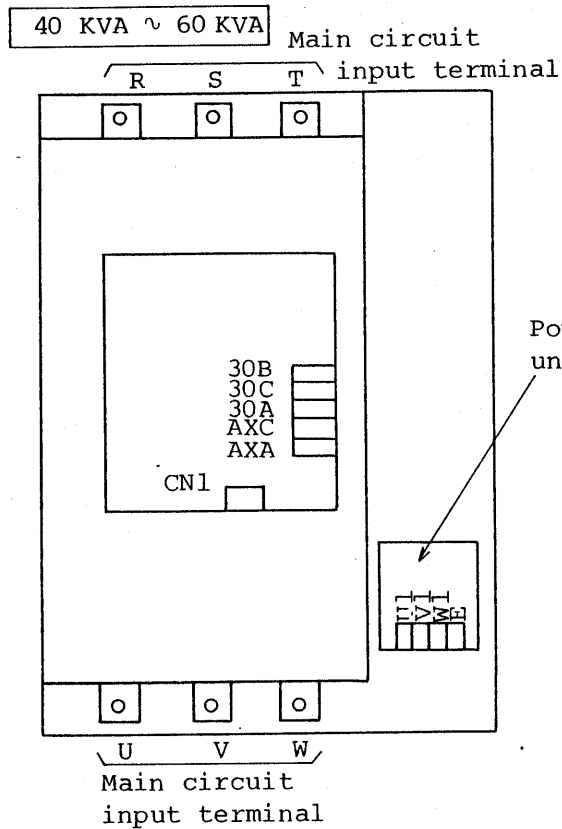
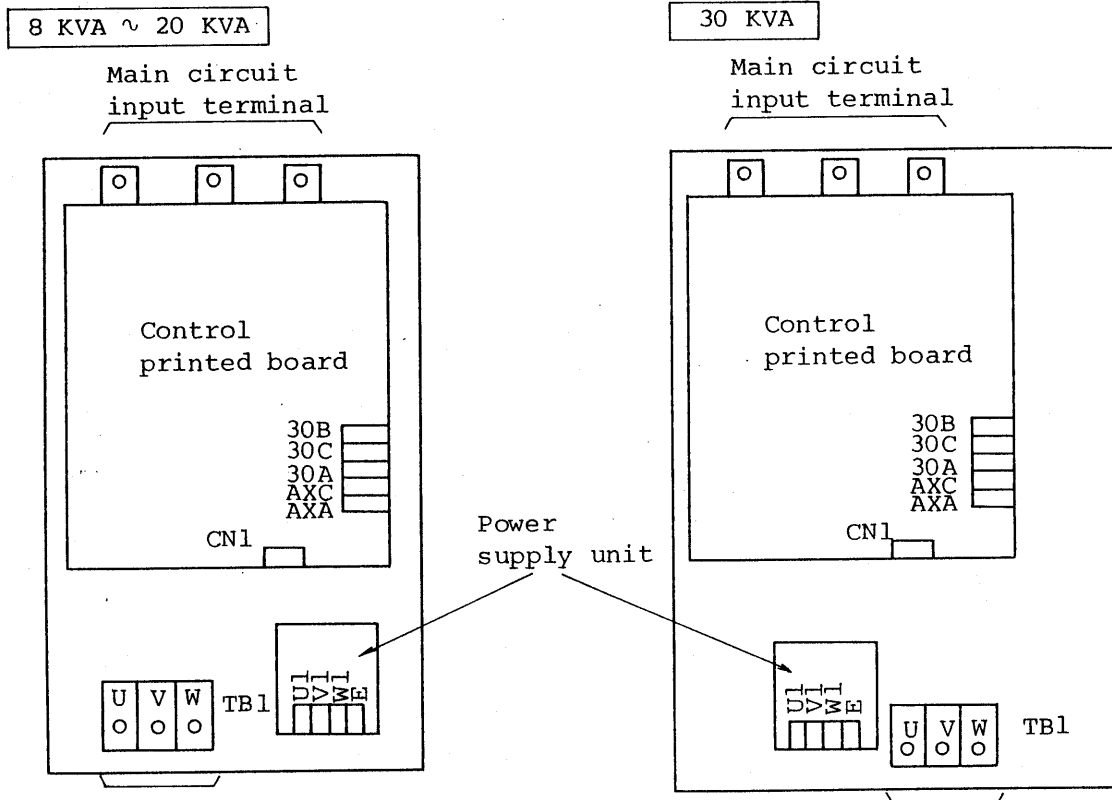

Connector's pin No. Terminal symbol

Connector CN1 terminals arrangement

1	2	3	4	5	6	7
12		M2	M1	REV	FOR	STP
	8	9	10	11	12	13
	13	11	12	M	RES	M
14	15	16	17	18	19	20
11	DBR	TH	M	M		

2-5. Table of Main Circuit Equipments and Wire Application

Interter type	RKNNG 809-2	RKNNG 110-2	RKNNG 150-2	RKKNG 200-2	RKKNG 300-2	RKKNG 400-2	RKKNG 500-2	RKKNG 600-2
Interter's capacity [kVA]	8	11	15	20	30	40	50	60
Rated output current [A]	23	32	44	57	86	115	143	173
Applied motor [kW]	5.5	7.5	11	15	22	30	37	45
Main circuit *1	8mm <sup>2</sup> ( " )	8mm <sup>2</sup> ( " )	14mm <sup>2</sup> ( " )	22mm <sup>2</sup> (30mm <sup>2</sup> )	22mm <sup>2</sup> (30mm <sup>2</sup> )	30mm <sup>2</sup> (80mm <sup>2</sup> )	50mm <sup>2</sup> (100mm <sup>2</sup> )	60mm <sup>2</sup> (150mm <sup>2</sup> )
Terminal's Input screw size Output	M5 M5	M5 M5	M5 M6	M5 M6	M8 M6	M8 M8	M8 M8	M8 M8
Control circuit	2mm <sup>2</sup>	2mm <sup>2</sup>	2mm <sup>2</sup>	2mm <sup>2</sup>	2mm <sup>2</sup>	2mm <sup>2</sup>	2mm <sup>2</sup>	2mm <sup>2</sup>
Terminal's screw size	M3	M3	M3	M3	M3	M3	M3	M3
Stranded wiring part (Soldered to connector)	0.3mm <sup>2</sup> solder -ed	0.3mm <sup>2</sup> solder -ed	0.3mm <sup>2</sup> solder -ed	0.3mm <sup>2</sup> solder -ed	0.3mm <sup>2</sup> solder -ed	0.3mm <sup>2</sup> solder -ed	0.3mm <sup>2</sup> solder -ed	0.3mm <sup>2</sup> solder -ed
MCCB	SA53i/ 80	SA63i/ 120	SA103 Hi/140	SA103 Hi/140	SA203 Hi/300	SA203 Hi/300	SA203 Hi/300	SA203 Hi/450
MC (52)	SRC 3631 -5-2	SRC 3631 -2	SC-2S	SC-3	SC-4S	SC-6	SC-8	SC-8
Fuse inside of unit	CS5F- 40	CS5F- 75	CS5F- 100	CS5F- 100	CS5F- 150	CS5F- 200	CS5F- 250	CS5F- 300
Applied thermal relay *2	TR-1S (20A~ 26A)	TR-3 (24A~ 36A)	TR-3 (34A~ 50A)	TR-3 (45A~ 67A)	TR-6 (65A~ 95A)	TR-6 (85A~ 125A)	TR-10H (110A~ 160A)	TR-10H (125A~ 185A)

\*1 Shows wire size for W11 cable application.

Use wire size in ( ) for 600V vinyl cable application.

\*2 Applied thermal relays are example for Fuji Electric standard 4P motor. For other than such case, thermal relays are to be chosen according to rated current value of the motor.

2-6 Dynamic Braking Unit (Option)

The dynamic braking unit consists of a dynamic brake power regulator (incorporated in the inverter unit subject to optional specification) and a dynamic brake resistor box (mounted outside of the inverter unit), and provides 5%ED of allowable dynamic brake frequency.

(1) Connection for dynamic brake resistor box (option)

It must be noted that the dynamic brake resistor box can be connected only with an inverter unit equipped with the dynamic brake power regulator. Still, the resistor box to be connected with must be one which is suitable to the inverter unit.

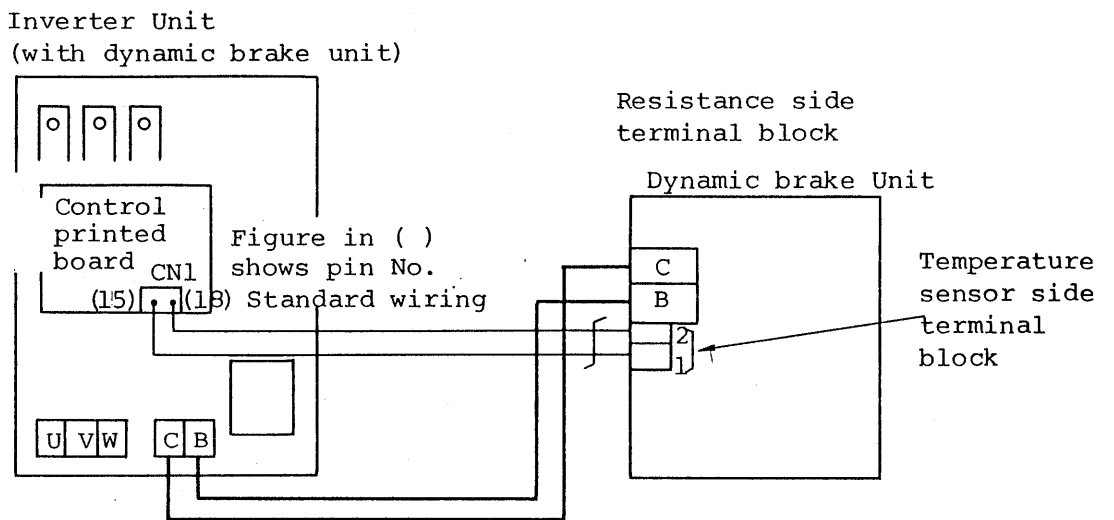

Connect as shown in above diagram.

Terminals arrangement

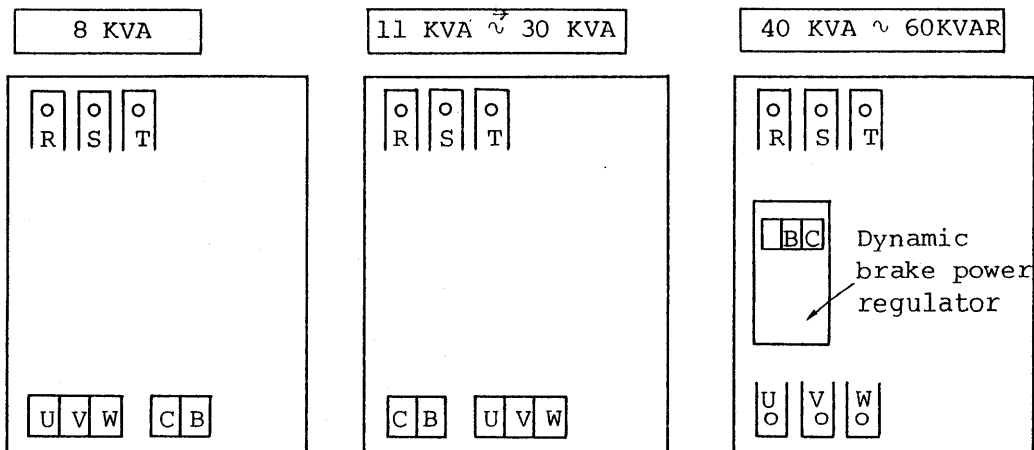

(2) Specification of Dynamic Braking Unit

Dynamic braking unit	Applied output max. kW	Resistance		Dimension [mm]					Mounting hole	Weight (kg)	Terminal block					
		kW	Resistance (ohm)	A	B	D	E	F			Terminal side			Temp. sensor side		
											Type	Screw size	Used wire size	Type	Screw size	Used wire size
DB-7.5B	5.5	1.2	16	280	140	248	368	248	4.8	BT-25	M4	LMFC 600V 3.5mm <sup>2</sup>	BT-25	M4	VSF 0.5mm <sup>2</sup>	
DB-10B	7.5	1.2	12													
DB-20B	15	2.4	6	400	660	628	240	8.6	8.6	AYBN 023-5	M4	LMFC 600V 5.5mm <sup>2</sup>	BT-25	M4	VSF 0.5mm <sup>2</sup>	
DB-30B	22	3.0	5													
DB-40B	30	3.6	4	660	660	628	240	10.3	10.3	AYBN 043-5	M5	LMFC 600V 8mm <sup>2</sup>	BT-25	M5	VSF 0.5mm <sup>2</sup>	
DB-50B	37	4.8	3													
DB-60B	45	6	2.4						16.0							

(3) Outside drawing of dynamic brake resistor box

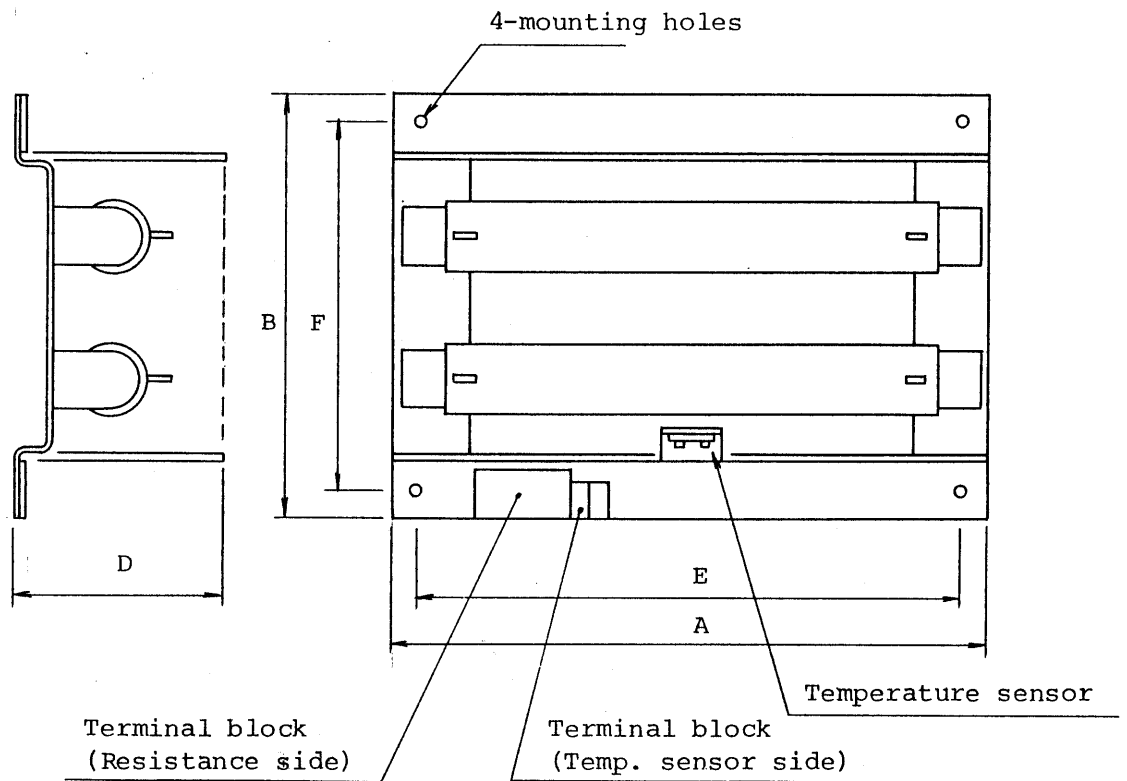

### 3. Trial Run

#### 3-1 Preparation for Operation

Make checking without fail on the following items prior to carrying out a trial run.

- (1) Input AC power meets to the rating. (3 $\phi$ , 200/220V, 50/60 Hz).
- (2) Input and output for the power circuit are correctly connected. (Input power with R, S, T and the motor with U, V, W).
- (3) Wiring for power circuit and control circuit is not earthed or not shorted.
- (4) Nothing of foreign substances such as chips of metal and wire mingled or stucked in the panel.
- (5) Affirm operation of the external sequence circuit.

#### 3-2 Trial Run

Upon making the trial run, by all means the following treatments should be prevented.

- . Connection of power supply with the inverter output terminals (U, V, W).
- . Earthing of the electrified part of main circuit or control circuit.

On account of ensuring security, make preparation separating the coupling and bolts, etc. which connect motor with machine so that the motor will be operable independently.

In the case of operating the motor keeping it in direct coupling with the machine, thorough care must be taken for safety.

- (1) Put every operation switch in off. Select the specified side for output frequency changeover switches of 50/60/100/120Hz. (They have been set into 60 Hz when shipped from the shop.)
- (2) Set the frequency adjuster in minimum.
- (3) Put in the breaker for wiring (then control circuit and sequence circuit will be activated), and observe the circumstances for a few minutes to check to see if there is nothing of abnormalities (heating, smoking and stench) in control circuit and sequence circuit, etc.
- (4) By pressing the operation push button, the main contactor can be put in with a command from the inverter. (The motor goes into running condition to rotate in revolutions about 1/20 of the rated speed.)

Under this condition ensure that the motor is running in correct direction. If the running direction is not correct, stop it once and change connection with order of phases at either side of the motor or the inverter output after putting the power off.

- (5) With setting VR raising slowly after confirmation of the running direction, check to see if running speed of the motor is meeting to the specified value at maximum notch position as well as if the motor terminal voltage then is in the specified value.
- (6) After making above confirmations, stop the motor once and set the setting VR in somewhat higher rate to check on acceleration and deceleration to be operated smoothly. Thus the trial run is completed, so that operation in coupling with the load can be made.

When any readjustment is required as the result of trial run, make adjustment referring to Section 4 "Adjustment and checking".

Note] Inverter output voltage, frequency and accelerating/decelerating time have been set at shipment as follows:

If any setting requires to be changed, make adjustment referring to Section 4 "Adjustment and checking".

Output frequency 60 Hz

Output voltage 200V, Constant torque feature

[ Page 24 V/f selection pattern ]  
[ No.3 ]

Acceleration time approx. 20 sec.

[ Switch [SWa] - "X1" side ]  
[ Volume [ACCEL] Maximum notch ]

Deceleration time approx. 20 sec.

[ Switch [SWb] - "X1" side ]  
[ Volume [DECEL] Maximum notch ]

#### 4. Adjustment and Checking

This transistor inverter has been completely adjusted at shipment in our factory.

Basically any adjustment at site will not be required, but take notice to the following points if any adjustment is needed on account of changing working condition, etc.

- (1) Use properly suitable meters.
- (2) Avoid careless turning of adjuster VR during operation.
- (3) By all means consult us if you need any adjustment other than those for FIN (for fine adjustment of frequency setting voltage), ADJ. (for adjustment of frequency indicator), ACCEL. (for acceleration time adjustment), DECEL. (for deceleration time adjustment), SWa (acceleration time multiplying factor change-over), SWb (deceleration time multiplying factor change-over), TORQUE (V/F ratio change-over) and FRE. (50 Hz, 60 Hz, 100 Hz, 120 Hz output frequency change-over).

##### 4-1 Preparation of Meters

In making adjustment and checking, suitable meters should be used to prevent cause of faulty adjustment and damage to the device and the meter.

Name of meter	Application	Notice on usage
Tester	Measurement of resistance. Judgement of condition of semi-conductor element.	
Digital volt-meter	Measurement of AC, DC voltage.	Take care so as not to contact with the adjacent pins.
Synchroscope	Measurement of AC, DC voltage waveform	
AC voltmeter	Measurement of AC voltage	Measurement of inverter output voltage is to be made with rectifying type voltmeter. To measure output current with movable iron piece type, use CT in larger VA.
AC ammeter	Measurement of AC current	
Frequency counter	Adjustment of frequency.	

#### 4-2 Adjusting Procedure

FIN (fine adjustment of frequency setting)

This is used when VR for frequency setting is externally connected. Make fine adjustment so that the frequency is come into 100% when VR for external setting is set into 100%.

Frequency increases by clockwisely turn. (Adjustable up to 105% maximum.)

ACCEL. (acceleration time adjustment)

DECEL. (deceleration time adjustment)

Although either of these provides adjustable range in 2 to 20 sec. for "x1" of SWa and SWb, and in 20 to 200 sec. for "x10", they are required to be adjusted of time according to each load.

If the frequency indicator is unstable during acceleration which shows excessively shortness of acceleration time, turn ACCEL in clockwise to lengthen the acceleration time. If OV trip lamp lights during deceleration, which shows excessively shortness of deceleration time, turn DECEL in clockwise to lengthen the deceleration time.

ADJ. (adjustment of frequency indicator)

Use a frequency meter provided with the scale of 60 Hz/120 Hz maximum respectively according to their specifications in the inverter output frequency 50, 60 Hz/100, 120 Hz.

Make fine adjustment so that the indication may come into 100% frequency during operation under 100% frequency. Clockwise turn increases the indication. In case of connecting two or more of the frequency indicators, make adjustment after connecting designated number of them. Difference in connected number of units causes difference in indication values.

SWa (acceleration time multiplying factor change-over),  
SWb (deceleration time multiplying factor change-over)

Put into "x1" side for adjustable range of 2 to 20 (sec.),  
and into "x10" side for 20 to 200 (sec.).

Either time of acceleration or deceleration is independently variable.

FRE (frequency change-over), 50Hz/60Hz/100Hz/120Hz

This is used for selection of the inverter rated output frequency. Frequency and multiplying factor will be selected in depressed side of the switch. For instance, the inverter rated output frequency can be set in "60 Hz" by putting 50Hz-60Hz selecting switch into 60Hz side and x1-x2 selecting switch into "x1". If "x2" is selected, the inverter rated output frequency will be set into "120Hz".

TORQUE (change-over in "T/F constant", "V/F higher" and "constant output")

This is used for selection of V/F ratio. V/F ratio is selected in depressed side of the switch.

Selection for FRE and TORQUE switches and variation of output V/F pattern therewith are shown in Table 1.

Above-mentioned regulating volume, change-over switch, fault indicator lamp and fault reset push button are arranged centralizing on the control printed board. The arrangement is shown in the next page.

## Arrangement of Adjuster Section

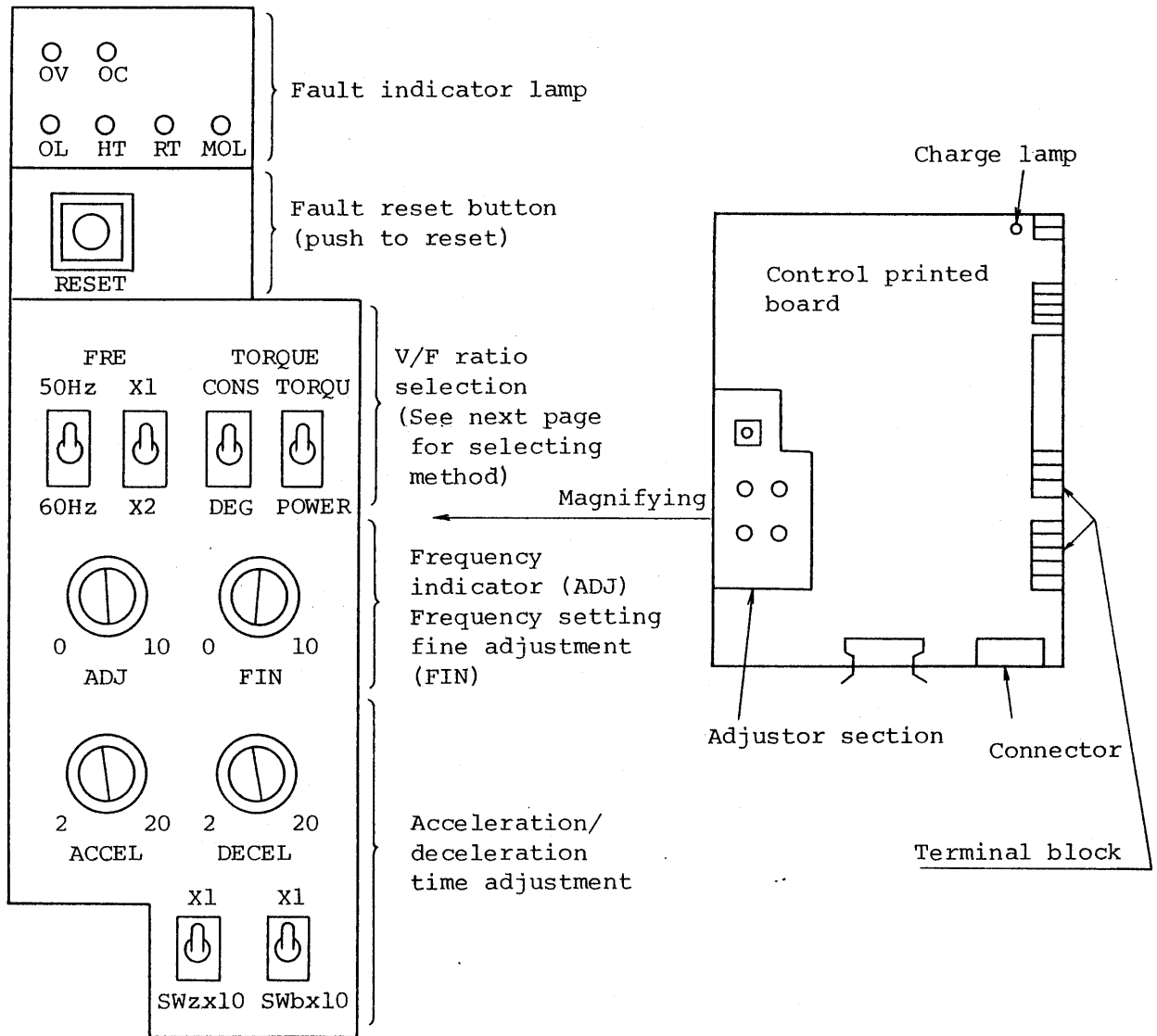

Table 1 Kind and Selecting Method of V/F Pattern

No.	Frequency change-over switch FRE		V/F ratio change-over sw. TORQUE		Inverter output V/F pattern	Remarks
	50Hz / 60Hz	X1 / X2	CONS / DEG	TORQU / POWER		
1	50Hz	X1	CONS	TORQU		Constant torque load
2	50Hz	X1	DEG	TORQU		
3	60Hz	X1	CONS	TORQU		Constant torque load
4	60Hz	X1	DEG	TORQU		
5	50Hz	X2	CONS	TORQU		To be applied for the motor in 200V, 100Hz rating
6	50Hz	X2	DEG	TORQU		Ditto
7	60Hz	X2	CONS	TORQU		To be applied for the motor in 200V, 120Hz rating
8	60Hz	X2	DEG	TORQU		Ditto
9	50Hz	X1 or X2	CONS or DEG	POWER		5 ~ 50Hz constant torque 5 ~ 100Hz constant output
10	60Hz	X1 or X2	CONS or DEG	POWER		6 ~ 60Hz constant torque 60 ~ 120Hz constant output

[Note] In handling these change-over switches, by all means changeover them with the motor inverter keeping in stop condition.

#### 4-3 List of Checking Terminals

Use a measuring instrument in high input impedance (digital voltmeter, synchroscope, etc.) for checking, where care must be taken to let it not contact with adjacent terminals.

Control Printed Board EP-2060			
Check pin	Name of function, Object of use	Adjustment, Voltage, Waveform	Adjuster VR
CH1	Frequency setting voltage	0 ~ -10V -10V/100% at max. notch of adjuster VR.	FIN
CH2	V/F functions generator output	+10V/100% min. voltage adjustment at max. notch of adjuster VR.	VR10
CH4	Voltage regulator output	0 ~ -6V	
CH6	Accel./Decel. regulator output	Accel./Decel. time regulation (2 ~ 20 sec, 20 ~ 200 sec.) adjustable for output voltage 0 ~ +10V max. +8V ~ +10.5V.	ACCEL. SWa DECEL. SWb
CH7	Output of amplifier for frequency meter	+10V/100% or 10V, 1mA meter.	ADJ
CH8	Current detecting output	0 ~ -4V	VR12
CH9	Synchronizing triangle wave output	Triangle wave peak adjustment	VR7
CH11	Forcibly synchronizing triangle wave output	Triangle wave peak adjustment	VR8
CH13	Reversing command	Reversing command "H".	
CH14	Normal run command	Normal run command "H".	
CH16	Base cut-off signal	"L" in base cut-off.	
CH19	Frequency zero detection	"L" in approx. 4% detection.	
CH21	Modulating triangle wave	-3V ~ +3V	VR15
P1	Control power	+24V ±2V	
P		+15V ±0.5V	
P <sub>0</sub>		+10V ±1V	
M	Standard voltage	0V (connect 0V of measuring instrument)	
N <sub>0</sub>	Control power	-7V ±1V	
N		-15V ±0.5V	

[Note] Measurable check pins with a tester or a digital voltmeter are CH1, CH2, CH7, P1, P, PO, NO and N. Other check pins than above are to be measured with a synchroscope, etc. Do never touch volumes and switches besides those on the controlling section.

Drive Printed Board EP-1991		
Check pin	Name of function Object of use	Adjustment, Voltage, Waveform
CH1	Output (Phase U)	
CH2	Output (Phase V)	
CH3	Output (Phase W)	
CH4	Modulating output (Phase U)	
CH5	" (Phase V)	
CH6	" (Phase W)	
CH10	" (Phase U)	
CH11	" (Phase W)	
CH7	Comb teeth form wave output	<p>Approx. 63 kHz <math>T_1 : T_2 = 2 : 1</math></p>
CH8	Base cut-off signal	"L" in base cut-off
CH9	Clock signal	24 x (inverter output frequency)

## 5. Maintenance

### 5-1 Daily Maintenance

Favorable maintenance and inspection are required for the device to successfully exhibit its performance and to continue highly reliable operation for a long term preventing it from occurrence of any trouble.

Care must be taken to the following points upon carrying out checking.

- (1) By all means cut off the power supply.
- (2) The smoothing condenser (an electrolysis condenser in larger capacity) can not discharge directly even after power supply cut off.

Prior to setting out with checking work, cut off the power supply and wait for several minutes to assure that the charge lamp fails. (Approx. 24V under the condition where charge lamp has been failed.)

- (3) In fitting or removal of connectors, hold the housing of connector by hand without fail.
- (4) Checking items

No.	Checking Item	Cycle	Contents	Trouble shooting
1	Magnetic connector Relay		. Are not contacts worn? . Is the operation smooth and sure?	Replacement
2	Transistor Diode Smoothing condenser Printed board		. Is not there any discoloration or stench? . Are not chips of metal or wire, etc. mingling therein?	Replace faulty parts after checking
3	Unit cooling fan		. Is it dynamically rotating after electrified? . Does not bearing part sound unusually?	Replace the fan
4	Terminals Connector		. Are not they loosened?	Further tightening

Remarks:

When mass of dust and dirt is accumulated therein, remove them blowing with compressed air lest any shock may not affect to the parts thereof. In case electric conductive dust or powder which may possibly cause faulty contact of relays are accumulated, however, suck off them by use of an electric vacuum cleaner.

5-2 Fault Diagnosis

By any chance if any abnormal phenomenon occurs during or upon operation, be not flurried and grasp the exact condition of the phenomenon to deal with it referring to the table of fault diagnosis under observation of the following notices. If still you can not restore the normal condition or you find out any damage to the parts, consult us directly.

(1) Notices

- a) Repair and adjustment of the device must be made only by the responsible person or persons.
- b) Checking of circuit etc. should be accomplished by use of such suitable instruments as tester, digital voltmeter, synchroscope and so on.
- c) Do never make removal and fitting of wiring under electrified condition as they may result in a short-circuit.
- d) Do not make adjustment of pre-adjusted VR without reason. When inevitably you are making adjustment, keep record of the position (number of notches) prior to adjustment so that it may exactly be restored to the original condition.

### 5-3 Table of Fault Diagnosis

- In case fault indicator lamp lights -

Note) When it is necessary to access inside of the unit in such the case of checking and trouble shooting, put MCCB off and wait for several minutes to ensure the charge lamp fails.

Kind	Cause of failure	Operation of inverter	Operation of motor	Check point	Trouble shooting
OC	Over-current	Base cut-off "Ax" off	Free run	Is not fuse broken?	Any diode or transistor possibly be broken. Check on them according to the clause separately given.
				Is not there any short circuit?	Removal of shorted circuit.
				Any rapid acceleration?	Lengthen acceleration time.
				Any rapid acceleration during usage of dynamic braking unit?	Lengthen deceleration time.
OV	Intermediate circuit over-voltage	Ditto	Ditto	Is not it a rapid decelerating operation?	Make deceleration time longer. (Deceleration time to correspond with $GD^2$ of load.)
				May not it be turned from load?	It is not applicable to continuous damping load.
				Is any momentary stop during operation?	Resume operation after assuring that both of motor and inverter are stopping.
OL	Inverter overload	Cut off base after deceleration. "Ax" off	Decelerate to stop	Is not inverter used under overload?	Remove overload factor.
HT	Cooling fin overheat			Has unit cooling fan been running normally? Is temperature in the panel normal?	Unit cooling fan is needed to be replaced. If abnormal, lower temperature in the panel by providing a vent hole, etc.
MOL	Motor thermal operation			Is not motor used under overload?	Remove overload factor.
RT	Dynamic brake resistance overheat			Is not dynamic brake circuit used under overload? Is frequency of application of dynamic brake circuit adequate?	Reduce frequency of applying dynamic brake circuit.

Example of trouble

Check point

Trouble shooting

MCCB trips at the same time as putting input MCCB on.

- . Error in external connection ...
- . Short circuit due to wire chips, etc. in MCCB secondary side. ...
- . Difference in input power voltage from AC200/220V ±10%. ..

- Correction of wiring.
- Removal of short circuit.
- Note) Difference in input may possibly cause damage to the device.

MCCB trips by pressing push button after putting MCCB on.

- . Improper current capacity of MCCB. ...
- . Short circuit in secondary side of 52, or short circuit or earthing of inverter output. Broken fuse in inverter. ...
- . Discolored or broken parts in inverter. ...

- Check it up with the table of application to individual machine type.
- Consult us with damaged condition.

Motor does not run even by pressing operating push button.

- . Erroneous wiring of circuit (Notice to connectors specially) ...
- . A switch between inverter output and motor, if provided. ...

- Correct the wiring, reset-in connectors.
- Close the switch after affirming that voltage is not imposed on inverter output through the switch.

Reverse turning direction of motor.

- . Removal of lock bolt for motor. ...
- . Locking of motor from load side. (too heavy load) ...
- . Erroneous order of phases for inverter output. ...
- . Erroneous selection of input for normal turn command and reverse turn command. ...

- Fit in a plug bolt after removing lock bolt.
- Make load lighter.
- Interchange between 2 phases of output causes reverse turn. (U-W-V → U-V-W)
- Reverse each input for normal turn command and reverse turn command.

Example of trouble

Check point

Trouble shooting

Motor can not be accelerated.	. Incorrect frequency setting ... . Too heavy load. ....	CH1 increases (-) with adjuster VR turned clockwise. Reduce the load.
Unsmooth acceleration for motor.	. Too short acceleration time. ...	Adjust acceleration time longer, with adjuster VR turning slowly by hand, after affirming availability of acceleration. (Turn VR of ACCEL in clockwise).
Unusually higher or lower rate of motor speed.	. Number of poles and specification of voltage. ... . Incorrectness in accel./decel. ratio on gears, etc. . Improper voltage for frequency setting. ... . Extremely dropped voltage between each motor terminal. ... . Unmatching selection of V/F pattern with specification. ...	Check them up with specifications and name plate.  Adjust it with FIN. Check on it under putting in CH6.  Special care must be taken when output transformer or ACL, etc. is provided therewith.  Affirm switching operation of V/F ratio.
Unstable speed during operation.	. Improper voltage for frequency setting. . Faulty contact of operation signal (52X) contacts. ... . Too heavy load. ... . Oscillating output of speed regulator. ...	Replace the relay. Reduce the load. Consult us after confirming the failure. (Measure CH6 with the synchroscope.)

Example of trouble

Check point

Trouble shooting

The motor naturally stopped with 52 falling into off.

- . Being used under overload. ...
- . Injammed load or the like. ...
- . If it occurred during decelerating operation. ...
- . Occurrence of power failure ..

- Remove overload factor.
- Adjust deceleration time longer. (Turn VR of DECEL in clockwise.)
- Restart after stopping the motor once.

Input MCCB tripped during operation.

- . Discoloration or breakage inside of inverter. ...
- . Improper temperature inside of the panel. ...
- . Unit cooling fan is not running. ...
- . Short circuit or earthing in output side. ...
- . Other load than of inverter in secondary side of MCCB. ...

- Transistors and diodes are possible to be broken. Check on them according to the clause separately given.
- If improper, provide a vent hole.
- Check on for elements.

Motor does not stop even with stop button pressed.

- . Erroneous wiring to external sequence circuit. ...
- . Fault in operation signal (52X) ...
- . Oscillation of output of speed regulator. ...
- . Repeating acceleration and deceleration. ...

- Correct the wiring.
- Replace the relay.
- Consult us after confirming the failure. (Measure CH6 with the synchroscope.)
- Press operation button once more and make deceleration time longer. (Turn VR of DECEL in clockwise.)

In spite of deceleration by use of dynamic braking unit, motor can not stop within deceleration time but inverter only stops.

- . Too much larger  $GD^2$  of load ...

- Make deceleration time correspond to  $GD^2$  of load. (To be within capacity range of dynamic braking unit.)