

VFK1 / VFN1 Series Adjustable Frequency A.C. Motor Drives

INSTRUCTION MANUAL



820 Lakeside Drive - Gurnee, IL 60031
PH: 847-855-9150 FAX: 847-855-9650
800-374-8266

www.drivecon.com E-mail: drive.sales@drivecon.com

k1-n1man.p65
Rev. 12-24-98

Table of Contents

Section 1 Introduction	
1.1 General	2
1.2 Receiving	2
Section 2 Installation	
2.1 Location	3
2.2 Clearance	3
2.3 Mounting Dimensions	4
2.4 Specifications	8
Section 3 Wiring	
3.1 Interconnection	11
3.2 Wire size & circuit breaker selection	12
3.3 Grounding	13
3.4 Motor thermal overload relay	14
3.5 Brake motor magnetic contactor	14
3.6 Special warning for wiring	14
Section 4 Remote control function	
4.1 Location of main parts	16
4.2 Function description of main circuit terminal (TM1)	18
4.3 Function description of control terminal (TM2)	19
4.4 Function description of jumper	24
Section 5 Digital operator control	
5.1 Introduction and configuration	25
5.2 Function parameter setting	29
5.3 Function description	30
5.4 Special function setting	53
Section 6 Test run	
6.1 Precaution checks before test run	56
6.2 Test run	57
Section 7 Setting and adjustment	
7.1 General description of settings and adjustments	58
7.2 Example of digital operator control and frequency command	59
Section 8 Fault indications	61
Section 9 Maintenance	65
Reference	
a. Measurement of voltage and current	66
b. Troubleshooting procedure.	67
c. Electromagnetic compatibility (EMC) of inverter.	69
Appendix A Peripheral - Ground Fault Protection	73
Appendix B Peripheral - Digital Operator Extension	74
Appendix C Peripheral D61530 / D61531 input isolator	75
User Program List	80
Terminal Function List	82

Warning!

The VFK/VFN inverter contains hazardous internal voltages and should be serviced only by qualified personnel. Most components are not user serviceable therefore, consult Drivecon if a problem should arise.

**Drivecon
820 Lakeside Drive
Gurnee, IL 60031 USA**

**Phone: (847) 855-9150
Fax: (847) 855-9650**

Definitions:

Qualified Person:

For the purpose of this instruction manual and product labels, a QUALIFIED PERSON is one who is familiar with the installation, construction, operation and maintenance of the equipment, and the hazards involved. In addition, the person must have the following qualifications:

1. Is trained and authorized to energize, de-energize, clear, ground and tag circuits and equipment in accordance with established safety practices.
2. Is trained in the proper care and use of protective equipment such as rubber gloves, hard hat, safety glasses or face shields, flash clothing, etc., in accordance with established safety practices.
3. Is trained in rendering first aid.

DANGER: For the purpose of this manual and product labels, DANGER indicates loss of life, severe personal injury or substantial property damage WILL result if proper precautions are not taken.

WARNING: For the purpose of this manual and product labels, WARNING indicates loss of life, severe personal injury or substantial property damage CAN result if proper precautions are not taken.

CAUTION: For the purpose of this manual and product labels, CAUTION indicates minor personal injury or property damage can result if precautions are not taken.

NOTE: For the purpose of this manual and product labels, NOTES merely call attention to information that is especially significant in understanding and operating the drive.

Inverter K1/N1 Series

Thank you for purchasing this Drivecon inverter / variable frequency AC motor drive.

Note: Please read and understand this manual before operating the inverter.

Danger!: Make sure all sources of power are removed from inverter and internal capacitors are discharged or personal injury may result.

This will ensure safe and reliable operation of the inverter.

Quick setup and operation procedure.

Warning: Insure only qualified personnel install and operate this inverter. Installation must comply with NEC and all appropriate local codes.

1. AC mains power L1, L2, and L3
Motor connections T1, T2, and T3

Control wiring - Terminal strip TM2 - note numbering on page 14.

Select either keypad or remote terminal strip operation.

2. **Keypad operation**

The following functions must be set.

Fn10, Fn11 = 0. Fn6 = 60Hz and Fn25 = Operating frequency.

3. **Remote operation**

Install forward, reverse, speed reference and other connections to terminal strips TM2 - refer to interconnection diagram page 9.

The following functions must be set:

Fn10, Fn11 = 1, Fn6=60Hz

Fn26, Fn27, Fn28, Fn29, Fn30 as required - refer to manual pages 42 and 43.

4. **CAUTION:** When connecting a potentiometer to terminals 12, 13, and 14 this should be in strict compliance with wiring detail on page 21. Incorrect wiring will damage the inverter.

5. **Control supply voltage**

On K1-4110, K1-4150 and K1-4220 set the supply voltage by removing the front cover and repositioning the link on the supply transformer. A caution label indicates this must be done prior to operation of the inverter.

THE ABOVE ARE MINIMUM SETTINGS TO OPERATE THE INVERTER. MANY OTHER OPERATING FEATURES ARE AVAILABLE AND ARE DETAILED IN THIS MANUAL.

IT IS STRONGLY RECOMMENDED THAT THIS MANUAL BE READ AND UNDERSTOOD TO OBTAIN OPTIMUM PERFORMANCE FROM YOUR INVERTER. SHOULD ANY QUESTIONS EXIST PLEASE FEEL FREE TO CONTACT DRIVECON CORPORATION AT (847) 918-1406.

Thank You!

We at Drivecon and affiliated dealer appreciate your purchase of this inverter or, adjustable frequency drive. When properly installed, operated and maintained, the inverter will provide a lifetime of reliable operation. It is mandatory that the person who operates, inspects, and maintains this equipment thoroughly read and understand this manual.

This instruction manual has been designed to serve as a self-supporting guide for the proper installation, operation, and maintenance of the inverter adjustable frequency drive. If you require additional assistance please feel free to contact either your local supplier or Drivecon at (847) 855-9150.



DONOT touch any circuit components while AC main power is on or immediately after the main AC power is disconnected from the unit. You must wait until the red charge lamp (LED 101) on the main control board goes out before servicing the inverter or motor.

DONOT make any interconnection or contact with the circuit before inverter is disconnected from AC power line. Failure to adhere to this warning could result in serious or personal injury.

Section 1: Introduction

1.1 General

K1/N1 series are high performance 230V or 460V general purpose inverters which incorporate a high efficiency Pulse Width Modulated (PWM) design. The output closely approximates a sinusoidal current waveform to allow variable speed control of any conventional 3 phase squirrel cage induction motor.

1.2 Receiving

This unit has been put through strict Q.C. tests at the factory prior to shipment.

Before unpacking please check the following:

Please compare the description of the product found on the name plate with your purchase order.

Inspect for transport damage (serious damage of carton may lead to unit damage)

Please check the following after unpacking:

If the specifications (current and voltage) on the front cover name plate matches your application requirements.

Check all the electrical connections and screws.

Verify that there is no visible damage to any of the components.

Note: If any part of the inverter is damaged or lost, please notify the carrier and Drivecon immediately.

Caution: Should damage occur during transportation, installation and power supply connection may lead to further damage.

Section 2: Installation

2.1 Location

Proper location of the inverter is imperative to achieve specified performance & normal operation life expectancy. Inverter should always be installed in areas where the following conditions exist:

Ambient operating temperature range:

Enclosed type: -10° to 40°C (14 to 104°F)

Open chassis type: -10° to 50°C (14 to 122°F)

Rating of enclosure N1, 204, 207, 215, 222 all rated at NEMA1/IP20. K1-207, 215, 222, 237, K1-407, 415, 422, 437 all rated protected chassis IP00. K1 255-2220, 455-4220 all are NEMA1/IP20.

Protected from rain and moisture.

Shielded from direct sunlight.

Free from metallic particles and corrosive gas.

Free from excessive vibration. (Below 0.5G)

2.2 Clearance

For cooling and maintenance purpose, sufficient clearance (as shown in figure 2.1) around inverter is necessary to keep effective ventilation. Inverter must be installed with heat sink fins oriented vertically.

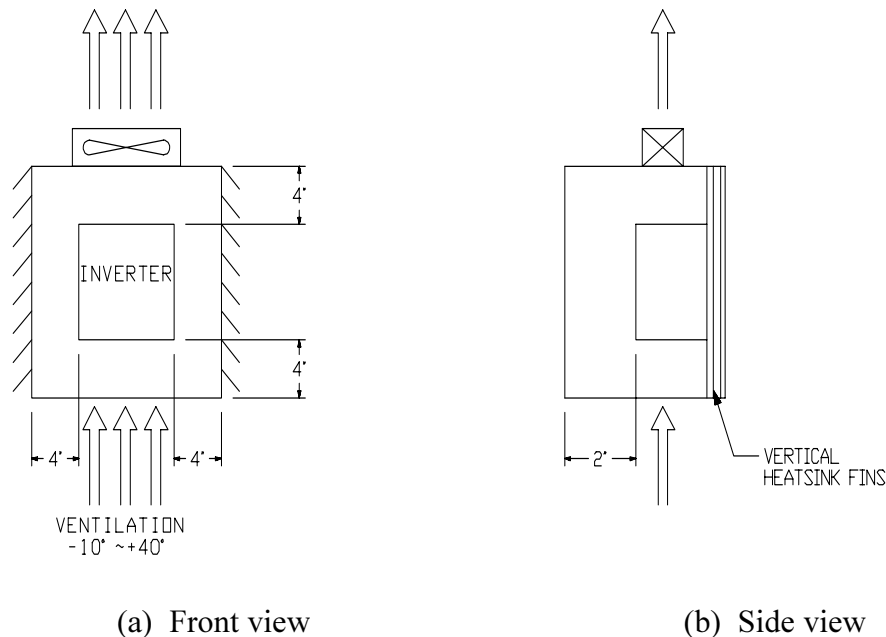

Fig. 2.1 Location and Positioning of inverter.

2.3 Mounting Dimensions

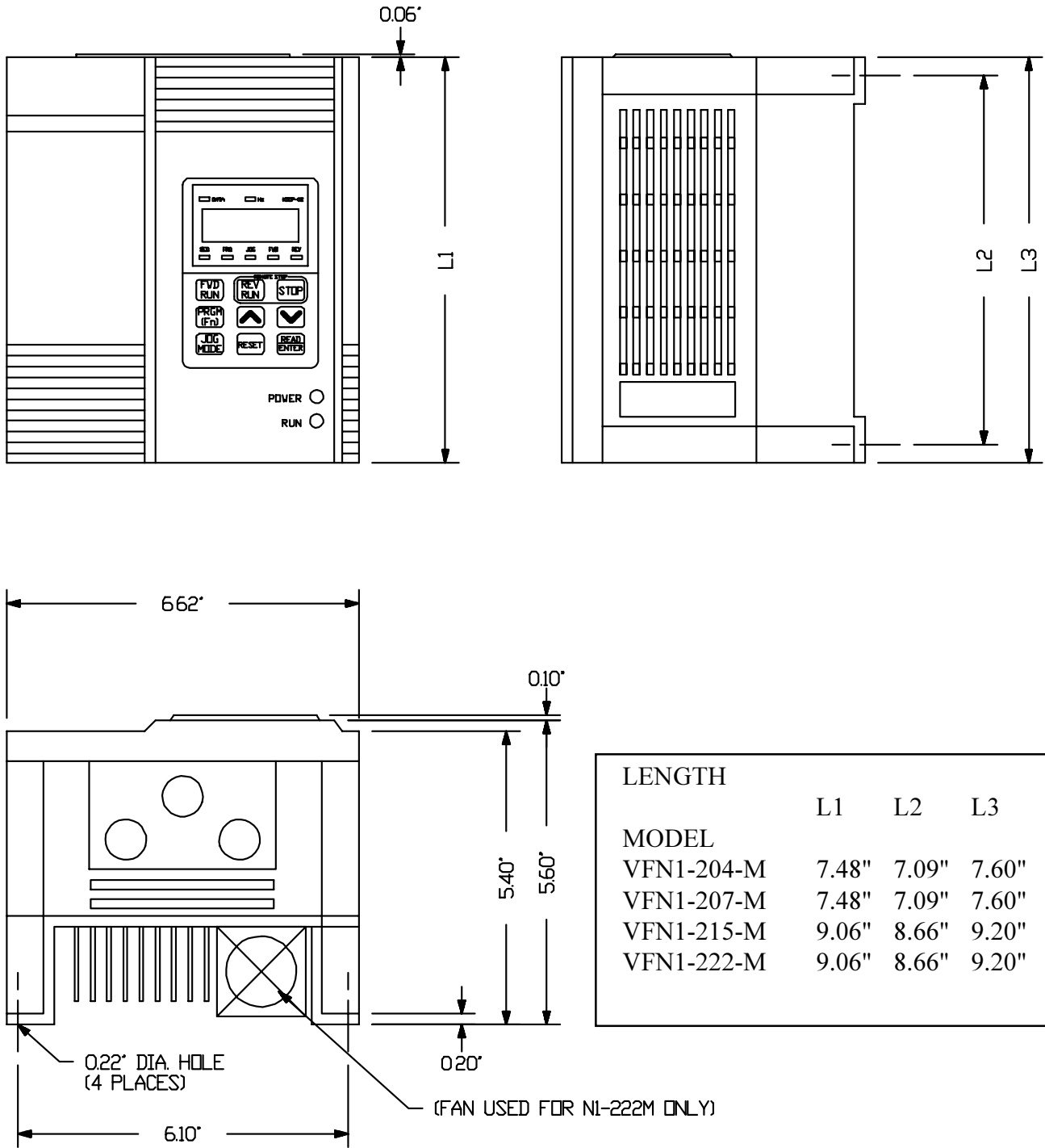
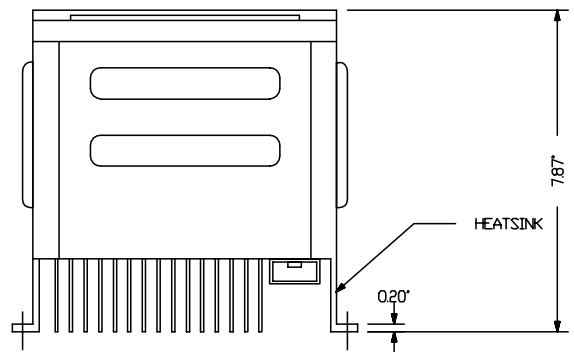
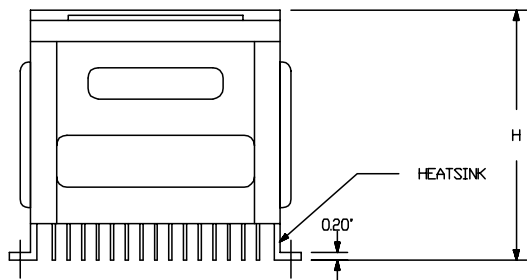
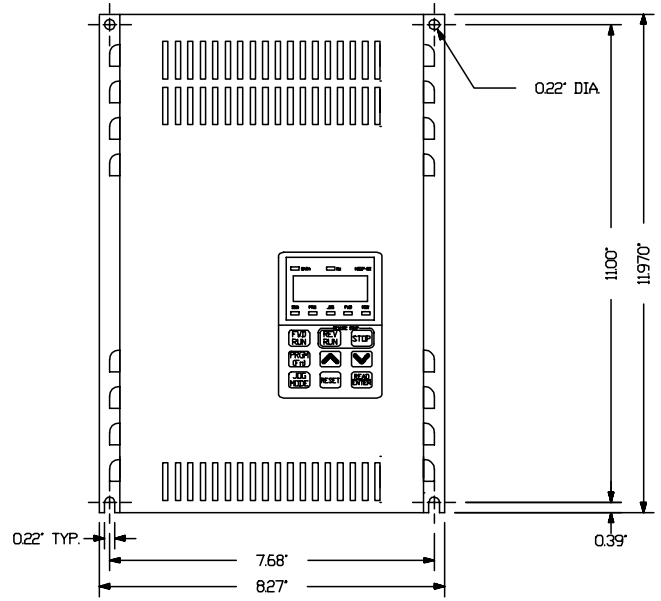
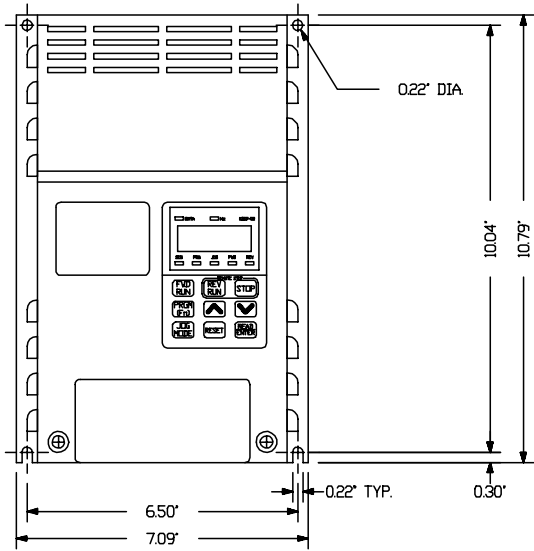

Fig. 2.2 Mounting Dimension of VFN1 204-222



VFK1-207-M, 215-M, 222-M
 VFK1-237-M3
 VFK1-407-M3, 415-M3, 422-M3

VFK1-437-M3

MODEL #	H
VFK1-207-M, 215-M	6.00"
VFK1-222-M, 237-M3	7.00"
VFK1-407, 415, 422-M3	6.00"

Fig. 2.3a Mounting Dimension of VFK1 207-237, 407-437

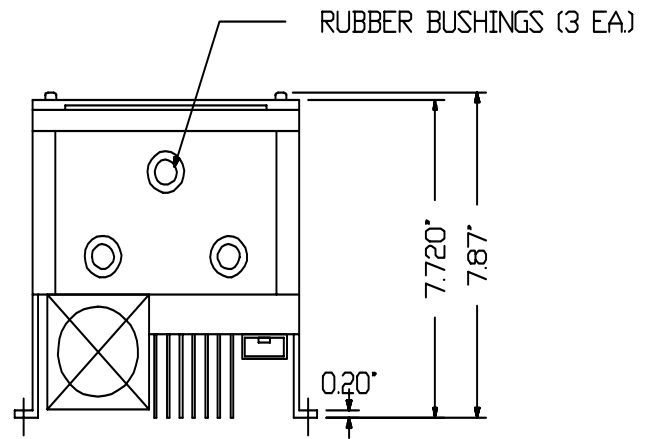
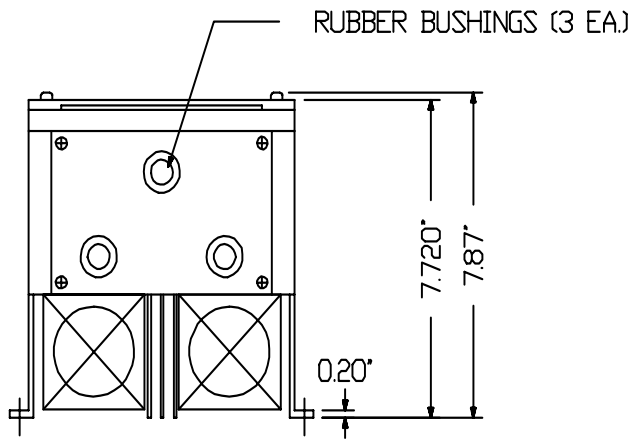
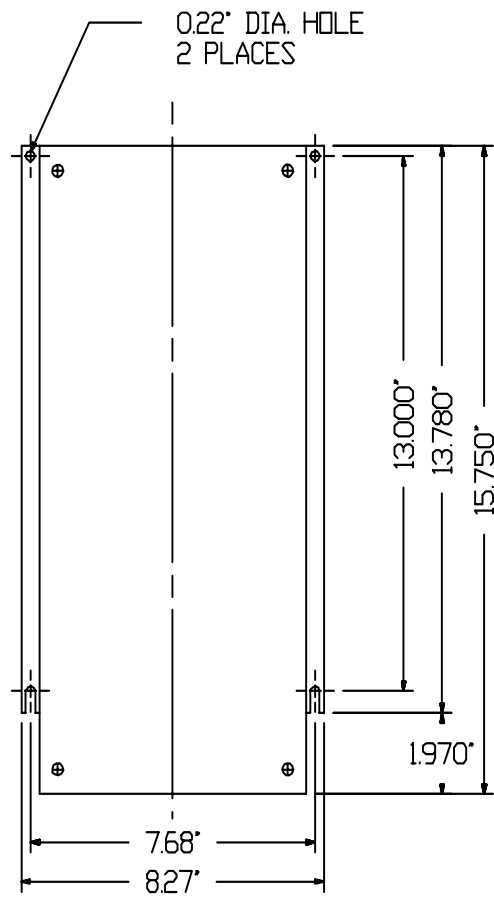
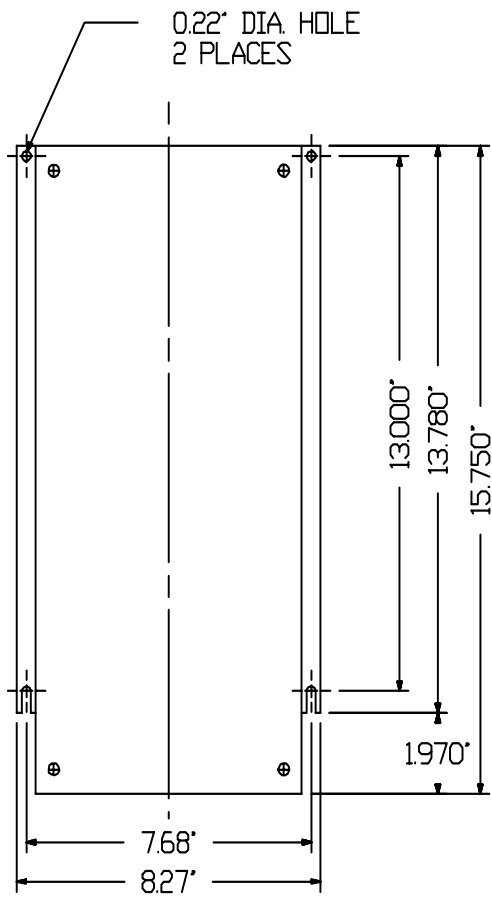

VFK1-275-M3

VFK1-255-M3
VFK1-455-M3
VFK1-475-M3

Fig. 2.3b Mounting Dimension of VFK1 255-275, 455-475

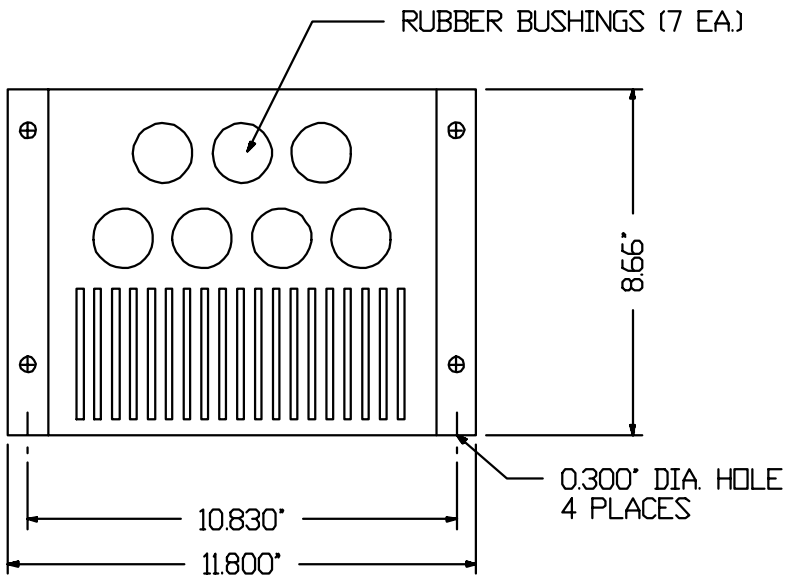
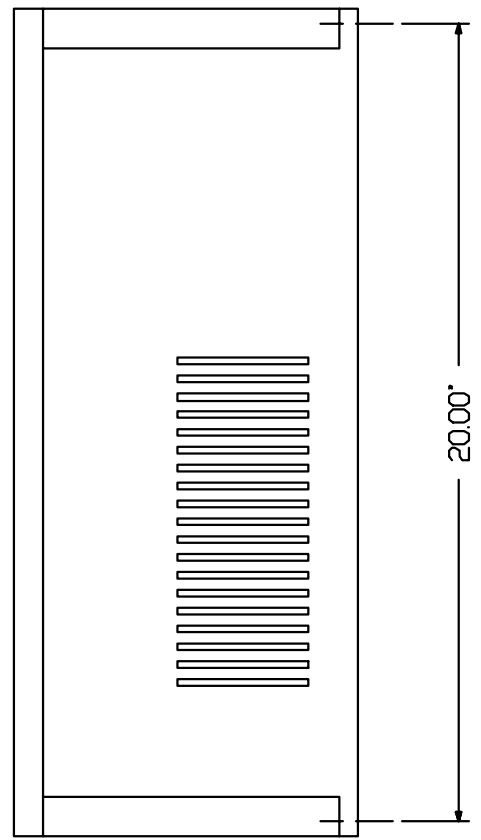
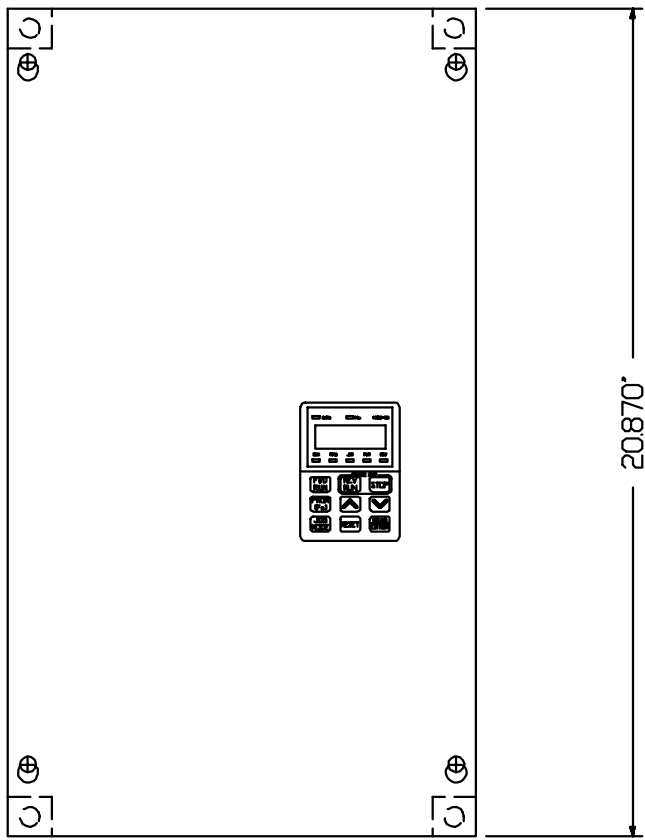

VFK1-2110-M3, VFK1-2150-M3
 VFK1-2220-M3
 VFK1-4110-M3, VFK1-4150-M3
 VFK1-4220-M3

Fig. 2.3c Mounting Dimension of VFK1 2110-2220, 4110-4220

Standard Specifications

Model	N1-204-M	N1-207-M	N1-215-M	N1-222-M
Motor Rating (KW)	0.4	0.75	1.5	2.2
Constant Torque Motor Rating (HP)	0.5	1	2	3
Variable Torque Motor Rating (HP)	0.5	1	2	3
Constant Torque Rated Current (A) (1)	3.1	4.5	7.5	10.5
Variable Torque Rated Current (A) (2)	3.6	5.2	8.6	12.0
Rated Output (KVA)	1.2	1.7	2.9	4
Weight (Kg)	2.2	2.2	2.2	5.5
Input Voltage	1 phase / 3 phase, 200-240 VAC (+ - 10%), 50/60 Hz (+ - 5%)			
Output Voltage	3 phase, 200-240 VAC			

Model	K1-207-M	K1-215-M	K1-222-M	K1-237-M3	K1-255-M3	K1-275-M3	K1-2110-M3	K1-2150-M3	K1-2220-M3
Motor Rating (KW)	0.75	1.5	2.2	3.7	5.5	7.5	11.2	15	22.4
Constant Torque Motor Rating (HP)	1	2	3	5	7.5	10	15	20	30
Variable Torque Motor Rating (HP)	1	2	3	5/7.5	10	15	20	30	40
Constant Torque Rated Current (A) (1)	4.5	7.5	10.5	17.5	26	35	52	70	105
Variable Torque Rated Current (A) (2)	3.6	8.6	12.0	22.0	30.0	42.0	60.0	81.0	121.0
Rated Output (KVA)	1.7	2.9	4	6.7	9.9	13.3	19.8	26.7	40
Weight (Kg)	3.5	3.7	5.5	5.8	9.4	10	19.5	21.5	22.5
Input Voltage	3 phase, 200-240 VAC (+ / - 10%), 50/60 Hz (+ / - 5%)								
Output Voltage	3 phase, 200-240 VAC								

Model	K1-407-M3	K1-415-M3	K1-422-M3	K1-437-M3	K1-455-M3	K1-475-M3	K1-4110-M3	K1-4150-M3	K1-4220-M3
Motor Rating (KW)	0.75	1.5	2.2	3.7	5.5	7.5	11.2	15	22.4
Constant Torque Motor Rating (HP)	1	2	3	5	7.5	10	15	20	30
Variable Torque Motor Rating (HP)	1	2	3	5/7.5	10	15	20	30	40
Constant Torque Rated Current (A) (1)	2.3	3.8	5.2	8.8	13	17.5	26	35	52
Variable Torque Rated Current (A) (2)	2.6	4.4	6.0	11.0	15.0	21.0	30.0	40.0	60.0
Rated Output (KVA)	1.7	2.9	4	6.7	9.9	13.3	19.8	26.7	40
Weight (Kg)	4.2	4.2	4.2	8.4	10	10	20.5	21.5	22.5
Input Voltage	3 phase, 380-460 VAC (+ / - 10%), 50/60 Hz (+ / - 5%)								
Output Voltage	3 phase, 380-460 VAC								

- (1) 150% overload for 60 seconds
 (2) 120% overload for 30 seconds

		Heat loss of inverter (Watts) at full load	H: Calori-Metric value of heat radiated by inverter. (K cal/hr.)	Q: Necessary ventilation volume $\Delta t = 10^{\circ}\text{C}$ (tt ³ /min.)	S: Vent port area (Minimum value (in ²))	Minimum surface area in ² steel enclosure without venting 40° Amb. $\Delta t=10^{\circ}\text{C}$	Minimum surface area in ² plastic enclosure without venting 40° Amb. $\Delta t=10^{\circ}\text{C}$
Model	kW						
N1-204-M	0.4	35	30.1	6.1	2.3	1,085	1,550
N1-207-M	0.75	45	38.7	7.9	2.3	1,255	1,984
N1-215-M	0.15	65	55.9	11.4	2.9	1,829	2,883
N1-222-M	2.2	90	77.4	15.7	5.4	2,542	3,985
K1-207-M3 K1-407-M3	0.75	40	34.4	7.1	2.3	1,131	1,767
K1-215-M3 K1-415-M3	1.5	60	51.6	10.7	2.8	1,689	2,650
K1-222-M3 K1-422-M3	2.2	70	60.2	12.5	3.4	1,968	3,100
K1-237-M3 K1-437-M3	4.0	135	116.1	23.6	11.5	3,782	5,983
K1-255-M3 K1-455-M3	5.5	190	163.4	37.6	15.3	5,349	8,418
K1-275-M3 K1-475-M3	7.5	240	206.4	42.5	20.0	6,760	10,620
K1-2110-M3 K1-4110-M3	11	310	266.6	54.6	25.6	9,612	13,736
K1-2150-M3 K1-4150-M3	15	453	389.6	80.0	37.5	14,050	20,062
K1-2220-M3 K1-4220-M3	22	673	578.8	118.9	55.8	20,868	29,813

Common Specifications

Control Mode	Sinusoidal Wave PWM Control	
Frequency	Accuracy	+ / - 0.5% (-10°C~40°C)
	Resolution	0.1 Hz
	Range	1-180Hz
	Start Frequency	1 Hz
	Adjustment	Digital Operator; external variable resistor 10K ohm; 1~5VDC, 4~20mA DC, 0-10VDC
	Multispeed	7 steps (0-180Hz)
	Upper Limit	1-180 Hz
	Lower Limit	0-180 Hz
Accel / Decel Time	0.1-800 sec. independently programmable dual set points	
Jog Frequency	0-180 Hz	
V/F Pattern	16 pre-defined patterns, One Curve Programmable	
Braking Torque	100% with external D.B. resistor, 20% K1 2110, K1 4110 or larger.	
DC Braking Injection Frequency	1-10 Hz	
Alarm Signal	N/O or N/C Fault Relay (250V/1 Amp)	
Multi-Function O/P	Open Collector Output (35V / 50mA DC)	
Frequency Signal O/P	0-10 VDC Digital Meter, 1 mA Full Scale Moving Coil Meter	
Stop Mode	Decelerate or Free Run to Stop	
Reset	Closed Contact Point or Pressing RESET	
Display	4 Digits 7 Segments LED & Status LED's	
Protection	Overcurrent, Overvoltage, Overtemperature, (except N1 series) Low voltage, stall prevention. (Ground fault protection: ZCT2)**	
D.B. Voltage	379 VDC off, 385 VDC on (200 series); 760 VDC off, 770 VDC on (400 series)	
Communication	RS232, RS485* (32 units maximum)	
Overload (1) Constant torque (2) Variable torque	(1) 150%, 1 minute (2) 120% for 30 seconds	
Overcurrent	200% peak trip	
Transient Power Failure Ride Through	16 ms	
Operation Temperature	-10~+40°C (+50°C with cover removed)	
Humidity	0-95% non-condensing	
Vibration	Below 0.5G	
Environment	Dust free, dry, non-corrosive	

* Optional

** Optional for models VFK/N 204-275, VFN 407-475

Section 3 Wiring

3.1 Interconnection

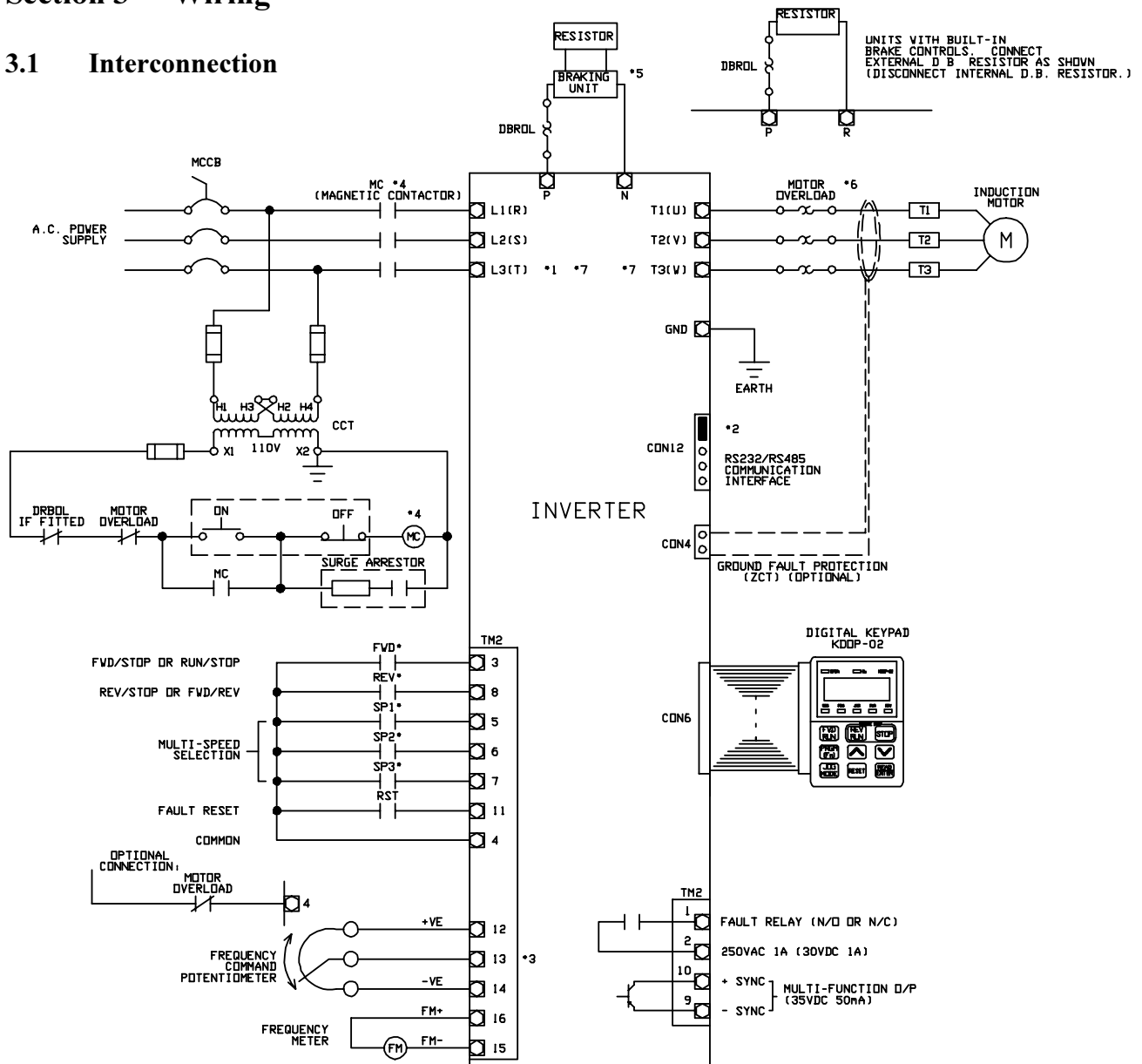

- * Note:
- In single phase applications, connect AC power supply to L1 & L2 of the inverter.
 - Use jumper to short PIN1 and PIN2 when CON12 is not used.
 - Do not connect wiper of frequency command potentiometer to terminal 12 or 14 of TM2. This will damage the inverter.
 - MC use is optional depending upon application if not used; wire motor overload contacts in series with terminal 4 common of inverter's control wiring.
 - Built in brake unit not provided on units VFK1-2110M, VFK1-4110M and larger. Connect braking unit and resistors as shown. (Consult factory for details)
 - See page 14 section 3.4 on required motor thermal overload relay.
 - See page 12,13 for tightening torque values of TM1 screw terminals.
 - Terminations to inverter must be made with either listed field wiring lug kits or listed crimp type ring terminals.
 - NEC requires thermal overload protection for motor branch circuits.
 - Ground fault protection is standard on start only. Optional Ground Fault protection while running is shown.

3.2 Wire Size and Circuit Breaker Selection

3.2.1 Circuit Breaker Selection

Caution: To guarantee the safety of equipment, circuit disconnecting means and branch circuit protection between power source and inverter is necessary. The branch circuit protection can either be in the form of thermal magnetic moulded case circuit breaker (MCCB) or current limiting time delay fuse protection. Please follow all national and local electric codes.

Units rated for 240VAC input are suited for use on a circuit capable of delivering not more than 5000 RMS symmetrical amperes, 240V maximum. Units rated for 480VAC input are suitable for use on a circuit capable of delivering not more than 5000 RMS symmetrical amperes, 480V maximum.

DO NOT connect power source to inverter output terminal (T1, T2, T3) otherwise the unit will be damaged.

NEVER install Magnetic Contactor (MC) between inverter output terminal and motor. The transient de-energizing surge of magnetic contactor will destroy the unit or lead inverter to trip.

Table 3.1, 3.2, 3.3 shown below provides the suggested rating of MCCB or MC for each of the inverter ratings.

You should install RC surge absorbers across the coils of any control relays or contactors installed within the system of the inverter. Metal Oxide Varistors (MOV's) alone are not acceptable. See figure below for the proper surge absorbers.

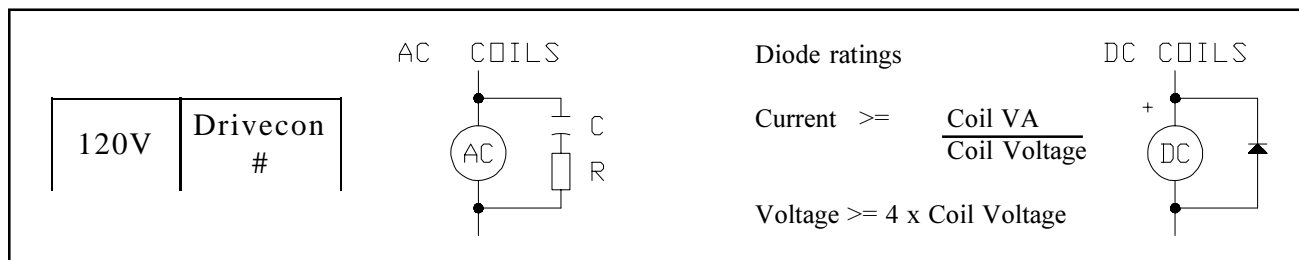

3.2.2 Wire Size

The wire used in the main power circuit should be sized according to Table 3.1, 3.2, 3.3 shown below. Use copper conductors only, size field wiring based on 75°C wire only.

Table 3.1 Specification of N1-2XX series

Inverter type		N1-204-M	N1-207-M	N1-215-M	N1-222-M
MCCB / Fuse rating		10A		20A	30A
MC (A/B IEC rated)		100A09ND3			100A12ND3
Wire Size *1 (minimum)	TM1	14 AWG			
	TM2	18 AWG			
Screw *2 Terminal size	TM1 (torque)	M4-(24in.-lbs.)			
	TM2	M3 (7in.-lbs.)			

Table 3.2 K1-2XX Series

Inverter type		207M	215M	222M	237M3	255M3	275M3	2110M3	2150M3	2220M3	
MCCB		10A	20A		30A	40A	50A	80A	100A	150A	
MC (A/B IEC rated)		100A09ND3		100A12ND3	100A18ND3	100A30ND3	100A38ND3	100A60ND3	100A75ND3	100B110ND3	
Wire Size *1 (minimum)	TM1	14 AWG		12 AWG		10 AWG	8 AWG	6 AWG	4 AWG	2 AWG	
	TM2	18 AWG									
Screw *2 Terminal size	TM1 (torque)	M4 (10.5 in.-lbs.)				M6 (39 in.-lbs.)		M6 (22 in.-lbs.)	M8 (53in.-lbs.)	M8 (53in.-lbs.)	
	TM2	M3 (7in.-lbs.)									

Table 3.2 K1-4XX Series

Inverter type		407M	415M	422M	437M3	455M3	475M3	4110M3	4150M3	4220M3
MCCB		10A			15A	20A	30A	40A	50A	75A
MC (A/B IEC rated)		100A09ND3			100A12ND3	100A18ND3	100A30ND3	100A38ND3	100A45ND3	
Wire Size *1 (minimum)	TM1	14 AWG			12 AWG		10 AWG	8 AWG	4 AWG	
	TM2	18 AWG								
Screw *2 Terminal size	TM1 (torque)	M4 (16 in.-lbs)					M6 (22 in.-lbs.)			
	TM2	M3 (7in.-lbs.)								

Note: *1 Use copper conductors only, minimum size listed, size field wiring based on 75°C wire only.

*2 Use only U.L. listed field wiring lug kits or U.L. listed ring terminals.

3.3 Grounding

Connect positive ground using terminal E on the Main Circuit terminal (TM1).

- * Wire size should be at least 14 AWG minimum. The lead length should be kept as short as possible.
- * Ground resistance should be below 100 ohm.
- * **NEVER** ground inverter along with welding machines, large current motors....etc.
- * Where several inverter units are used together all of them should be directly grounded to a common point. Please follow the grounding instructions shown in Fig. 3.2.
- * **CAUTION:** Never ground or connect terminal N of inverter to neutral.

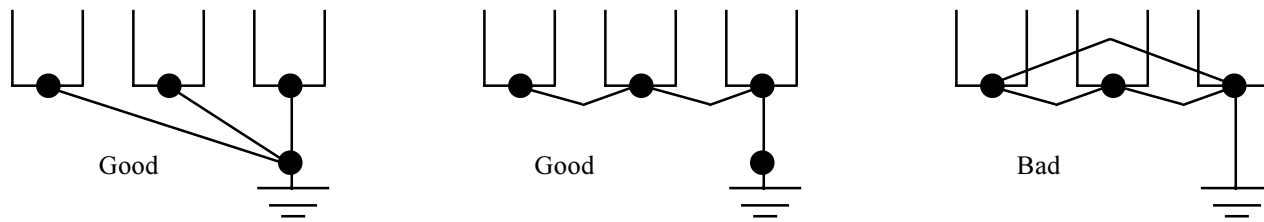

Fig. 3.2 Grounding of Multiple inverter.

3.4 Motor Thermal Overload Relay

To prevent the motor from overheating and to adhere to UL and NEC requirements, an external thermal relay (MOL) should be mounted between the inverter output terminal (T1, T2, T3) and the motor. (See Fig. 3.1)

- * Thermal overload relay is not required when using motor with thermal detectors embedded in the windings of the motor. TEFC fan cooled motors will overheat in low speed operation. The use of thermal detectors in the motor is recommended when using TEFC fan cooled motors. Thermal detectors will always provide a level of protection not available with conventional thermal overload relay.
- * The thermal overload relay should be adjusted to match the motor's full load rating.
- * When multiple motors are being driven by a single inverter a separate thermal overload relay should be provided for each motor.

3.5 Brake motor Magnetic Contactor

Inverter generates a variable voltage output. For this reason, when using a brake motor with inverter, the brake power supply must be connected directly to the AC line power...DO NOT connect to inverter output. This branch circuit should be fused in accordance with NEC regulations.

- * A suitable surge absorber is strongly recommended to be installed across the brake coil to prevent transient surge when the brake contactor is de-energized the brake contactor coil should also be suppressed.

For AC coil brakes, please use R-C supressor such as Drivecon number KVFCC-3

For DC coil brakes, please use diode type supressor.

3.6 Special Warning for Wiring

- * DO NOT connect AC power source to inverter output terminal (T1, T2, T3). This will seriously damage the unit.
- * DO NOT install magnetic contactor (MC) between the inverter output terminal and motor. Closing of such unit while inverter is in run mode will result in large transient current to damage the unit or lead inverter to trip. Consult Drivecon if such a contactor is required.
- * DO NOT install power factor correction capacitor between inverter output terminal (T1, T2, T3) and motor.
- * DO NOT megger the motor leads while inverter is connected to motor. The semiconductor output module (TRM) will be destroyed by high test voltage.
- * Source KVA must be limited to < 500 KVA to protect against premature rectifier assembly

failure. If Source KVA exceeds 500 KVA, then installation of appropriate reactor is required. If multiple inverter are used, installation of individual reactors is required - one reactor capable of combined amperage is not recommended. (see Table 3.4) Drivecon also recommends the use of line reactors in retrofit installations when the VFK1 is driving an older vintage wound rotor motor or NEMA design D motor. Please consult Drivecon if questions exist regarding line reactor applications.

Table 3.4 Specification of reactor for constant torque use, 3% impedance *

Type	Current (Amp)	Inductance (mH)	Drivecon Model #
N1-204-M	3	3.7	KLR3BTB
N1-207-M, K1-207-M	4	2.7	KLR4BTB
K1-215-M, N1-215-M	8	1.4	KLR8BTB
K1-222-M, N1-222-M	12	0.92	KLR12BTB
K1-237-M3	16	0.69	KLR16BTB
K1-255-M3	25	0.44	KLR25BTB
K1-275-M3	35	0.31	KLR35BTB
K1-2110-M3	55	0.245	KLR55BTB
K1-2150-M3	80	0.200	KLR80BTB
K1-2220-M3	110	0.138	KLR110BTB
K1-407-M3	2	11.0	KLR2ATB
K1-415-M3	4	5.5	KLR4ATB
K1-422-M3	6	3.6	KLR6ATB
K1-437-M3	8	2.7	KLR8ATB
K1-455-M3	12	1.8	KLR12ATB
K1-475-M3	16	1.3	KLR16ATB
K1-4110-M3	25	0.88	KLR25ATB
K1-4150-M3	35	0.63	KLR35ATB
K1-4220-M3	55	0.49	KLR55ATB

* 3% impedance is recommended on light duty applications.
 Use 5% impedance for maximum benefit and inverter protection. Substitute 'A' for 'B' in 3rd to last digit of 230V units or 'C' for 'A' in 3rd to last digit of 460V units.

Diagram 3.4 Input line reactor connections

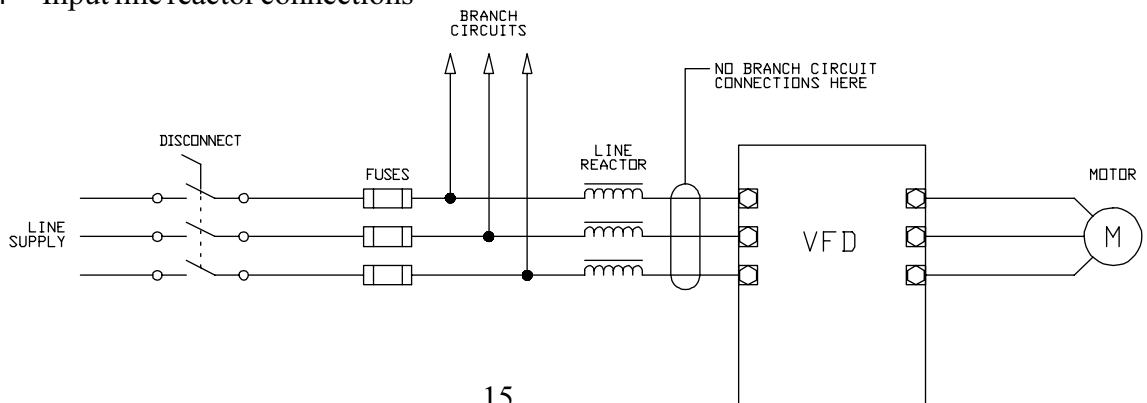

Section 4 Remote Control Function

4.1a Location of Main Parts of K1

The main parts of K1 series inverter are illustrated in Fig. 4.1a

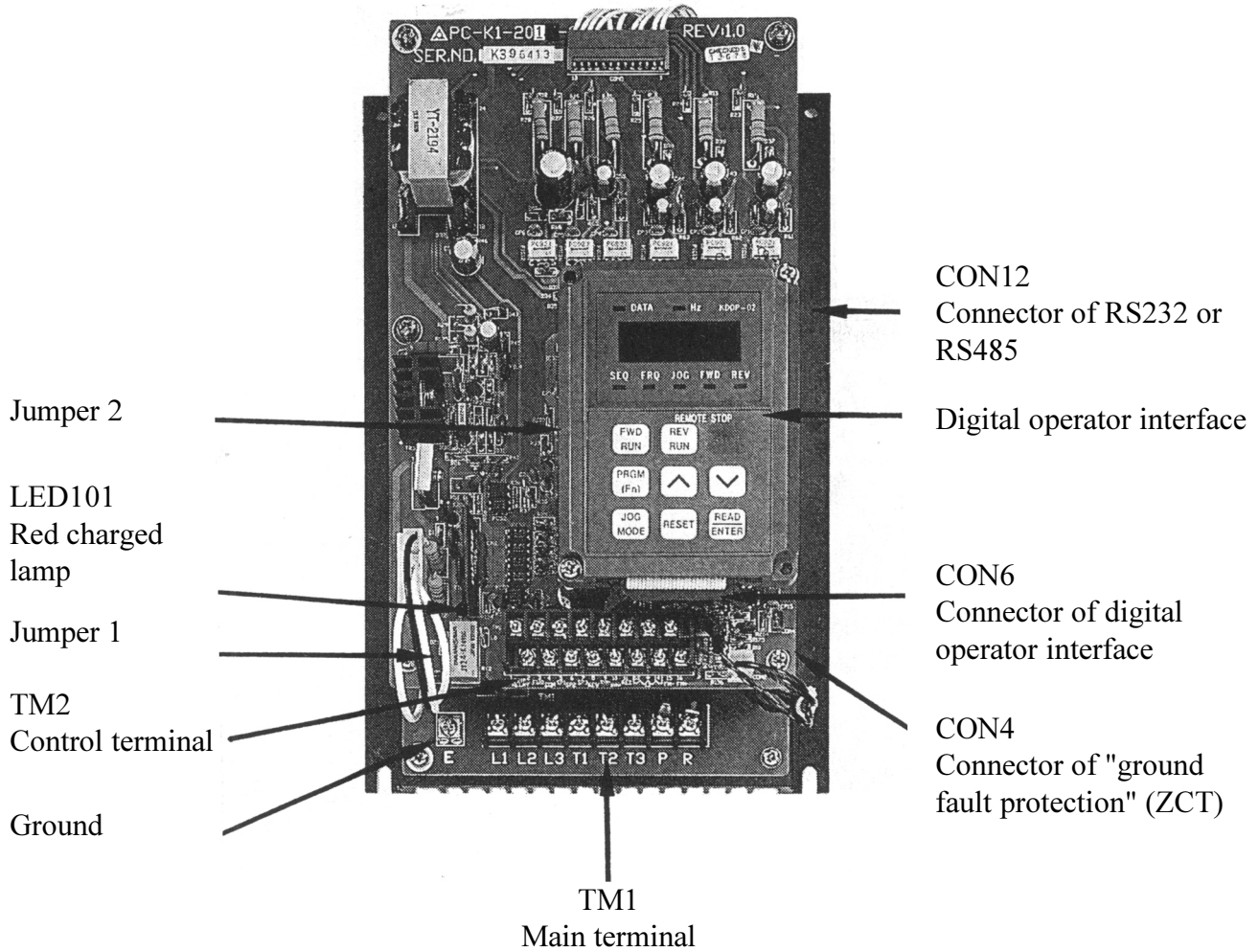
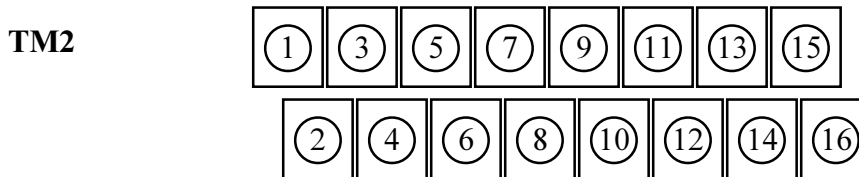
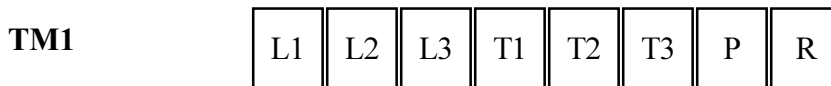

Fig. 4.1 Location of Main parts

Control terminal block (TM2) description.



Power terminal block (TM1) description.



VFK/N 204-275,
401-475

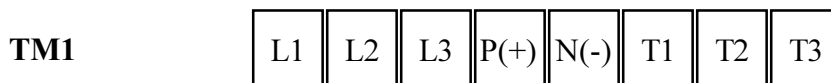

VFK 2110-2220,
4110-4220

4.1b Location of Main Parts of N1

The main parts of N1 series inverter are illustrated in Fig. 4.1b

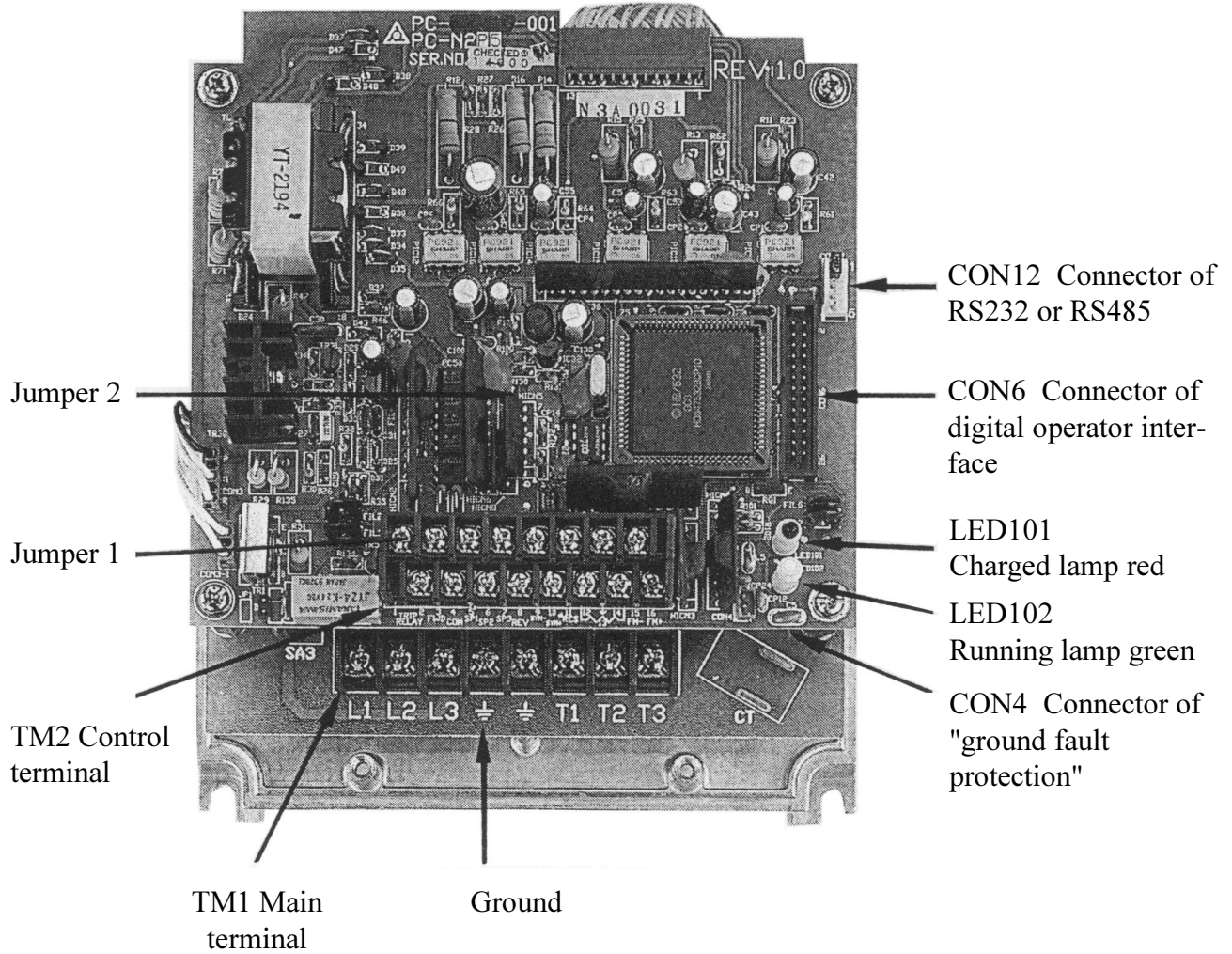
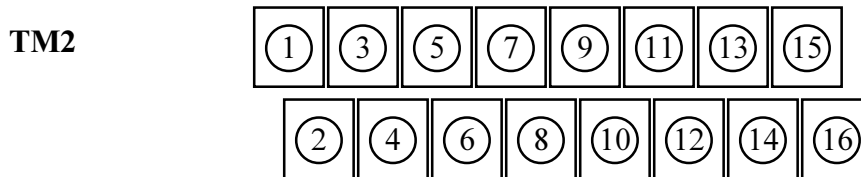
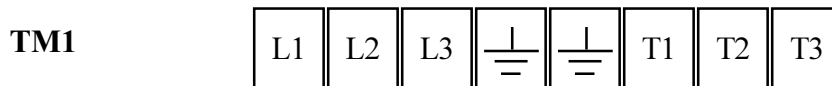

Fig. 4.1b Location of Main parts
Control terminal block (TM2) description.



Power terminal block (TM1) description.



4.2 Function and Description of Main Circuit Terminal (TM1)

Table 4.1 Function and description of TM1

Terminal Designation	Terminal Description	Function	Comments
L1(R) L2(S) L3(T)	Input terminals of AC line power	K1-200 (N1-200) series: 1 phase/ 3 phase, 200-240 VAC +/- 10% *1 50/60 Hz +/- 5% K1-400 series: 3 phase, 380-460 VAC +/- 10% 50/60 Hz +/- 5%	Use L1 and L2 Single Phase Input
T1(U) T2(V) T3(W)	Output terminals	K1-200 (N1-200) series: 3 phase, 200-230VAC K1-400 series: 3 phase, 380-460VAC	Never connect line power to motor terminals.
P/R P/N *3	External braking resistor connection terminals. Consult factory for details.	With the application of successive braking the inverter braking resistor may overheat. Please replace the built-in braking resistor with a resistor of larger watt rating externally. Replacement Procedures: *2, wires * Detach the built in resistor from P/R terminal and insulate exposed ends. *Install another resistor with the same resistance (ohm) but larger capacity (watt) * The standard resistance of inverter braking resistor is shown in table 4.2.	Used to connect the optional external Dynamic Brake Package.
E 	Ground terminal	Earth Grounding	Connect to earth ground

Note: Connect AC line power to terminals L1 and L2 in single phase application.

- *1. Single phase input only appropriate for VFN1 204-222 models.
- *2. The braking resistor of N1 series is soldered on the PC Board and can not be replaced.
- *3. There is no built-in brake unit in VFK1 models of 15HP and larger. An external brake unit; VFDB and resistor must be added for 100% brake torque.
- *4. Terminations to inverter must be made with either listed field wiring lug kits or listed crimp type ring terminals.

Table 4.2 Specifications of inverter Braking Resistor

Type	Resistance (ohm)	Capacity of build-in resistor (Watt)	Braking torque %
N1-204-M K1-207-M N1-207-M	150	20	285
		30	152
K1-215-M N1-215-M	120	30	103
K1-222-M N1-222-M	100	100	86
K1-237-M3 K1-255-M3 K1-275-M3	62	100	84
			63
			52
K1-2110-M3	Without braking resistor or module		20
K1-2150-M3			
K1-2220-M3			
K1-407-M3 K1-415-M3	620	20	148
K1-422-M3	500	30	73
K1-437-M3 K1-455-M3 K1-475-M3	150	150	126
			91
			73
K1-4110-M3	Without braking resistor or module		20
K1-4150-M3			
K1-4220-M3			

4.3 Function Description of Control Terminal (TM2)

4.3.1 Terminals 1 and 2

Function: Fault Relay.

Terminal 1 & 2 of TM2 are N.O. (Fn13=0) or N.C. (Fn13=1) relay contact to output alarm signal when protective circuit is activated.

Contact rating: 250 VAC/ 1 Amp or 30 VDC/ 1 Amp.

4.3.2 Terminals 3 and 8

Function: RUN/STOP, FWD/REV or FWD/STOP, REV/STOP Operation (effective in remote control Fn 10 = 1 only).

Inverter provides 2 methods of remote operation. This unique function allows the use of either RUN/STOP FWD/REV or FWD/STOP, REV/STOP, operation method to fit suit different application requirements.

These two operation methods are selected via Fn 3. Please refer to table 4.3 & Fig. 4.2 for details.

NOTE: MAINTAINED CONTACTS ARE REQUIRED FOR CONTINUOUS OPERATION.

Table 4.3 Remote operation via terminal 3 and 8

Fn10	Operation Mode	Fn3	Operation Method	S 3	S 4	Output
1	Remote Control	0	FWD / STOP REV / STOP	OFF	OFF	STOP
				ON	OFF	FORWARD
				OFF	ON	* REVERSE
				ON	ON	STOP
		1	FWD / REV RUN / STOP	OFF	OFF	STOP
				ON	OFF	FORWARD
				OFF	ON	STOP
				ON	ON	* REVERSE
0	Digital Operator Control	X	X	X	X	X

* Reverse run is allowed when Fn33=0

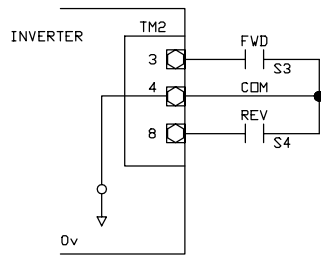

Fig. 4.2a Circuit connection

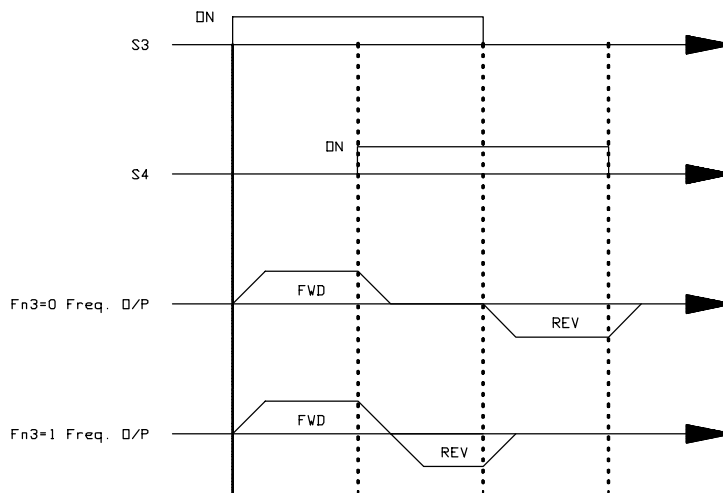

Fig. 4.2b Operation method selection example

4.3.3 Terminal 4 and 9

Function: Logic Common

Terminal 4 is the common for terminal 3-8, and 11.

Terminal 9 is the common for terminal 10 only.

4.3.4 Terminals 3, 5, 6 and 7

Function: Multi-speed operation, multi-function terminals.

Inverter allows selection of up to seven pre-set speeds. The frequency (speed) of each point is set by digital operator interface. Multi-speed control is described by table 4.4 & fig. 4.3. Terminals 5, 6, and 7 are also used to select the second acceleration and deceleration times, stop the inverter in either base block coast or deceleration stop. Refer to Fn46, Fn47, Fn48.

Table 4.3 Multi-speed operation

SP1	SP2	SP3	Inverter frequency output	Reference
OFF	OFF	OFF	Set by external signal or digital operator control	2
ON	OFF	OFF	Frequency set by Fn17	3
OFF	ON	OFF	Frequency set by Fn18	4
ON	ON	OFF	Frequency set by Fn19	5
OFF	OFF	ON	Frequency set by Fn20	6
ON	OFF	ON	Frequency set by Fn21	7
OFF	ON	ON	Frequency set by Fn22	8
ON	ON	ON	Frequency set by Fn23	9

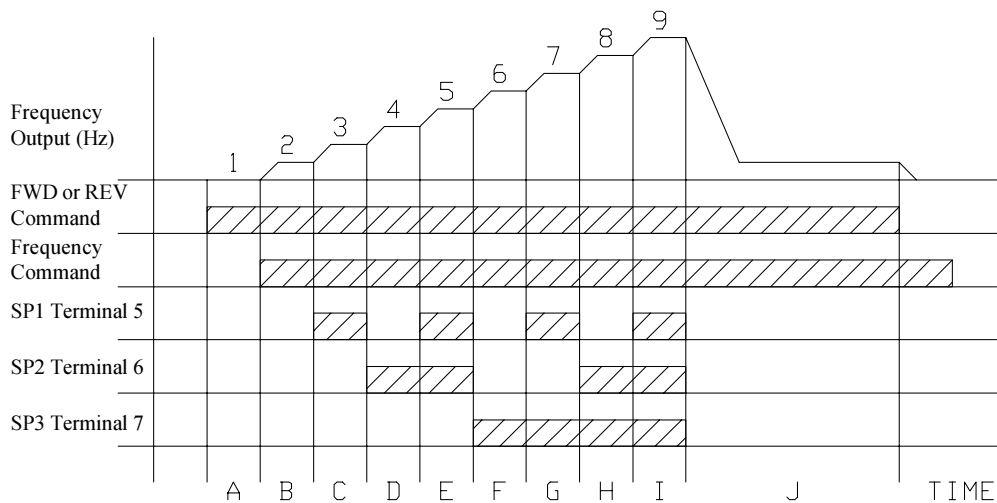

Table 4.4 Multi-speed operation example

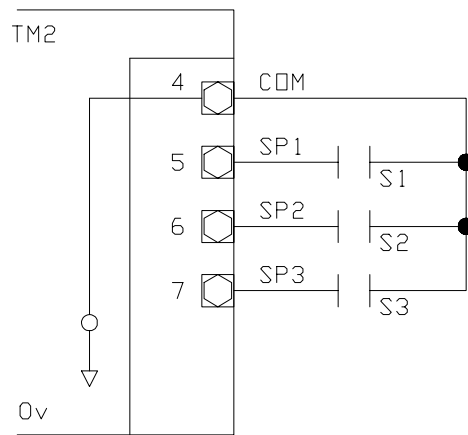

Fig. 4.3 Connection diagram

Time A: Frequency output is zero if **Fn7** is set to zero, otherwise inverter will run at setting of low limit (**Fn7**)

Time B: Run FWD/REV at remote frequency command (set by 10K ohm variable resistor or remote analog freq. signal) - Frequency output increases (or decreases) to frequency of remote frequency command and continues to run at constant frequency.

Time C: Frequency output increases to setting of **Fn17**, and continues to run at constant frequency.

Time D: Frequency output increases to setting of **Fn18**, and continues to run at constant frequency.

Time E: Frequency output increases to setting of **Fn19**, and continues to run at constant frequency.

Time F: Frequency output increases to setting of **Fn20**, and continues to run at constant frequency.

Time G: Frequency output increases to setting of **Fn21**, and continues to run at constant frequency.

Time H: Frequency output increases to setting of **Fn22**, and continues to run at constant frequency.

Time I: Frequency output increases to setting of **Fn23**, and continues to run at constant frequency.

Time J: Frequency output is at the same as Time B.

Note: The frequencies set by **Fn17** to **23** do not have to be in either ascending or descending order. **Fn17** to **23** can be set at any required frequencies between minimum and maximum frequency limits.

4.3.5 Terminal 10

Function: Open collector multi-function output

The software function of inverter allows the open collector output in either "run" mode, "constant speed" mode or when frequency output is greater or equal to **Fn9**. (Please refer to Fig. 4.4)

- a: "Run" mode output (when $F_{n8}=0$)
Level of terminal 10 will be changed from high to low whenever inverter enters into "run" mode.
- b: Constant speed mode (when $F_{n8}=1$)
Level of terminal 10 will be changed from high to low in inverter keeps running at constant frequency (between accel. and decel.).
- c: Output frequency is greater than or equal to F_{n9} (when $F_{n8}=2$)
Level of terminal 10 will be changed from high to low if the frequency output of the inverter is greater than or equal to F_{n9} .

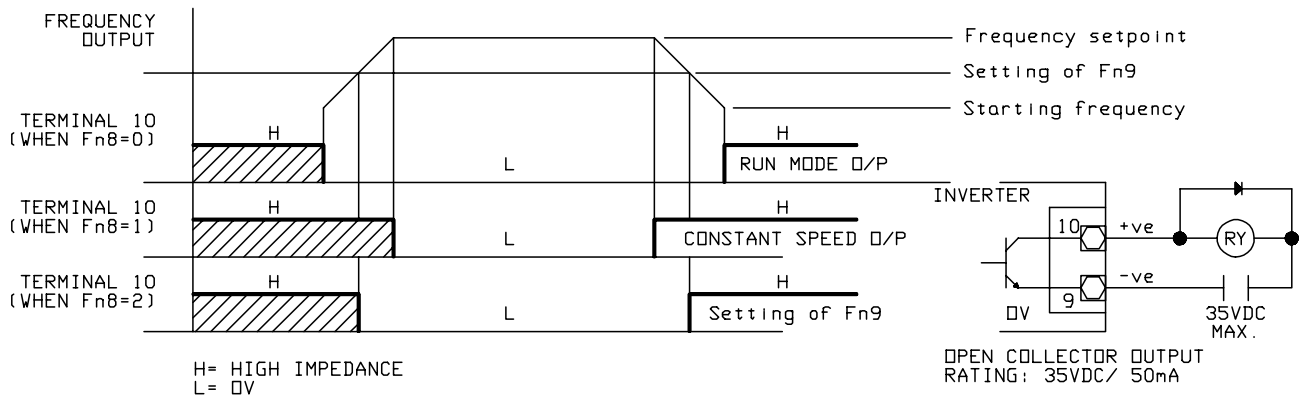

Fig. 4.4 Multi-function output

4.3.6 Terminal 11

Function: Reset of VFD

Reset inverter by connecting terminal 11 to ground common (terminal 4). Effective in both remote control ($F_{n10}=1$) and digital operator control ($F_{n10}=0$).

4.3.7 Terminal 12, 13 and 14

Function: Remote frequency command terminals (refer to Fig. 3.1)

Terminal 12: 5V positive terminals of 10K ohm frequency command potentiometer.

Terminal 13: Wiper of 10K ohm frequency command potentiometer or 0-10V, 1-5V, 4-20mA analog signal command positive terminal.

Terminal 14: Negative terminal of 10K ohm frequency command potentiometer or 0-10V, 1-5V, 4-20mA analog signal command negative terminal.

4.3.8 Terminals 15 and 16

Function remote frequency meter output.

Terminal 15: Negative terminal of full scale moving coil (DC 1mA) frequency meter or 0-10V digital frequency meter.

Terminal 16: Positive terminal of frequency meter.

4.4 Function Description of Jumper

Jumper 1 & 2 used in conjunction with Fn29 & Fn30 to select remote frequency command signal.
(Refer to Fn30 for details)

For instance, jump pin 1 & pin 2 of Jumper 1 to select 0-10V analog control signal.

Refer to Fig. 4.1 to find the location of Jumper 1 & 2.

Table 4.5 Function of jumper

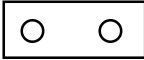
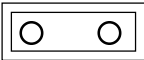
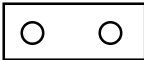
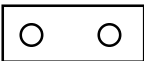
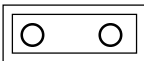
Fn30	Jumper 1	Jumper 2	Remote frequency command signal	Remark
1			0-10V analog signal	Effective in remote frequency command (Fn11=1) only.
0			10K ohm variable resistor 1-5VDC analog signal	
0			4-20mA analog signal	

Note: Jumper 1 is just a storage space for jumper connector. It contains no electrical connections.

Section 5 Digital Operator Control

5.1 Introduction and configuration

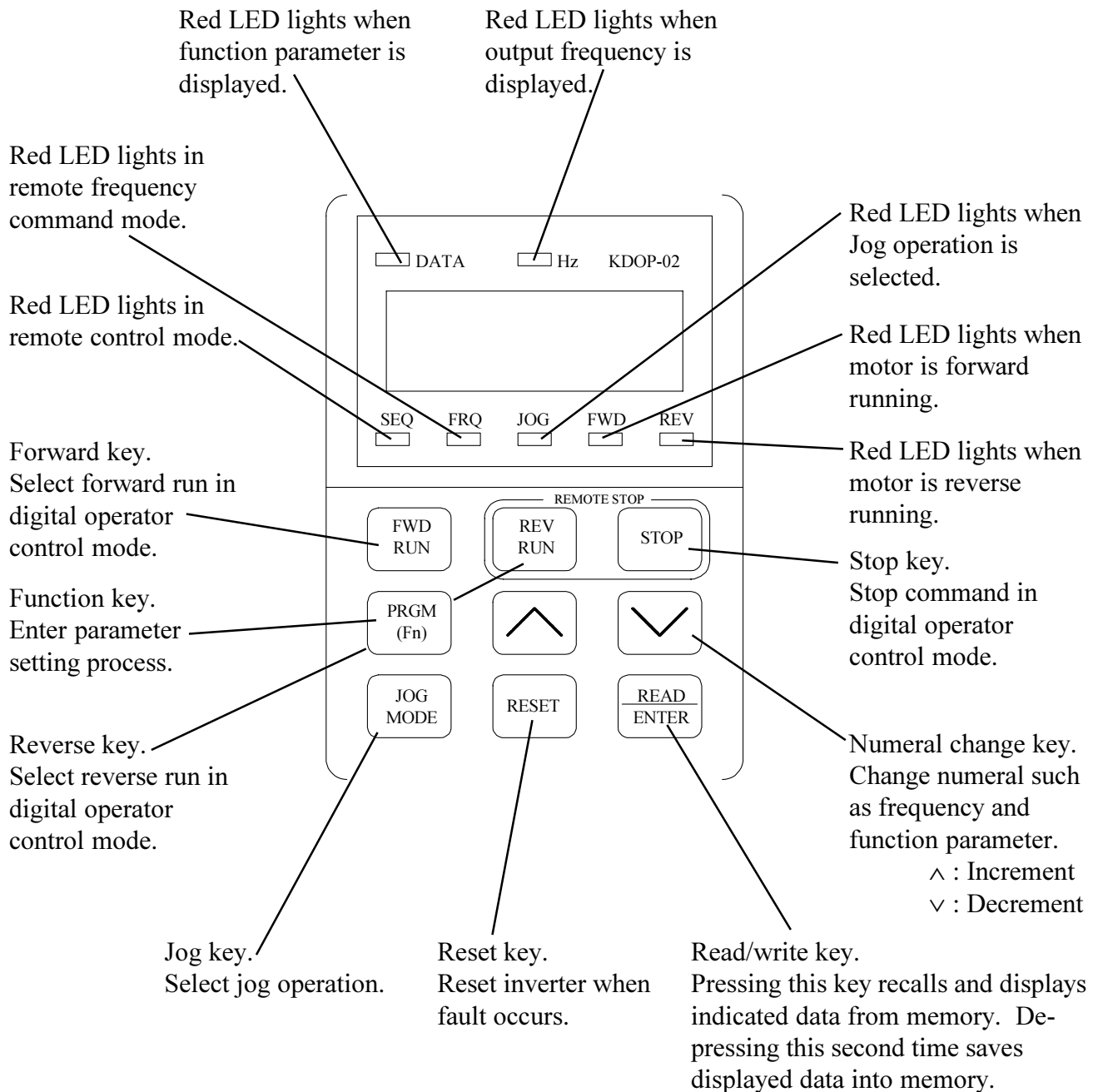

- * Factory setting for N1 series inverter remote control mode (Fn10=1, Fn11=1)
- * Factory setting for K1 series inverter is digital operator control mode (Fn10=0, Fn11=0)
- * Increase and decrease by pressing increment & decrement keys is only effective in local frequency command mode (Fn11=0)

NOTE: Important!

- * In remote control mode, press **STOP** and **REV** simultaneously for emergency stop.

5.1.1 Function List

CODE	DESCRIPTION	RANGE	SET UNIT	DEFAULT	REMARK
F _n 00	Communication ID No.	0-32		1	
F _n 01	Accel Time 1	0.1-800.0 sec.	0.1 sec.	5 sec. (10)	***
F _n 02	Decel Time 1	0.1-800.0 sec.	0.1 sec.	5 sec. (10)	***
F _n 03	Remote Operation Select	0: FWD/STOP, REV/STOP 1: FWD/REV RUN/STOP		0	
F _n 04	50/60 Hz ID no.			1	**
F _n 05	V/F Pattern Select	0-15		1	
F _n 06	Freq. Output Upper Limit	1-180Hz	0.1 Hz	60 Hz	
F _n 07	Freq. Output Lower Limit	0-180Hz	0.1 Hz	0 Hz	
F _n 08	Multi- Function Output	0: Run Mode 1: Constant Speed 2: Set frequency		0	
F _n 09	Set Frequency	1-180Hz	0.1 Hz	5 Hz	
F _n 10	Control Mode Select	0: Digital operator Frequency command 1: Remote control		0	*
F _n 11	Freq. Command Method Select	0: Digital operator frequency command 1: Remote frequency command.		0	*
F _n 12	Stall prevention level	0 or 110%-200%	1%	170%	**
F _n 13	Fault Relay Preset	0: Normally open N/O 1: Normally close N/C		0	
F _n 14	Reset	0: Disable 1: Enable		0	
F _n 15	Stall Prevention	1: Disable 2-8: Extend 2-8 times		1 (N/A)	***
F _n 16	Direct Start Inhibit	0: Disable 1: Enable		0	
F _n 17	Multi-Speed 1	0-180Hz	0.1 Hz	5 Hz	***
F _n 18	Multi-Speed 2	0-180Hz	0.1 Hz	10 Hz	***
F _n 19	Multi-Speed 3	0-180Hz	0.1 Hz	20 Hz	***
F _n 20	Multi-Speed 4	0-180Hz	0.1 Hz	30 Hz	***
F _n 21	Multi-Speed 5	0-180Hz	0.1 Hz	40 Hz	***
F _n 22	Multi-Speed 6	0-180Hz	0.1 Hz	50 Hz	***
F _n 23	Multi-Speed 7	0-180Hz	0.1 Hz	60 Hz	***
F _n 24	Jog Freq. Reference	0-180Hz	0.1 Hz	2 Hz	***
F _n 25	Master Freq. Reference	0-180Hz	0.1 Hz	5 Hz	***
F _n 26	BIAS of Freq. Reference	0-180Hz	0.1 Hz	0 Hz	***
F _n 27	Positive/Negative BIAS	0: Positive 1: Negative		0	***
F _n 28	Max. Speed set by full freq. ref.	1-180 Hz	0.1 Hz	60 Hz	***
F _n 29	Reverse freq. command select	0: Direct Signal 1: Reverse Signal		0	
F _n 30	Remote freq. command select	0: 1-5V, 4-20mA 10 Kohm V.R 1: 0-10V		0	
F _n 31	Con. Speed Stall Prevn. Enable Freq.	1-180Hz	0.1 Hz	60 Hz	(N/A)
	Con. Speed Stall Prevn. Enable level	0-160%	1%	160%	**
F _n 32	Con. Speed Stall Prevn. Decel. Time	0.1-800 sec.	0.1 sec.	0.8 sec. (3)	***
F _n 33	Reverse run prohibit	0: Disable 1: Enable		0	
F _n 34	Auto restart interval	0-800 sec.	0.1 sec.	5 sec.	
F _n 35	Auto restart times	0-10		0	
F _n 36	Scan times	0-9999		1001	***
F _n 37	Max. freq.	50-180Hz	0.1 Hz	60 Hz	
F _n 38	Max. voltage ratio	0-100%	0.1%	100%	
F _n 39	Mid. frequency	1-180Hz	0.1 Hz	3 Hz	
F _n 40	Mid. voltage ratio	0-100%	0.1%	7.5% (4.2)	
F _n 41	Min. frequency	1-180Hz	0.1 Hz	1.0 Hz	
F _n 42	Min. voltage ratio	0-100%	0.1%	7.5%	
F _n 43	Carrier frequency select	1440-3600 Hz	1 Hz	2880 Hz	

5.1.1 Function List (Continued)

CODE	DESCRIPTION	RANGE	SET UNIT	DEFAULT	REMARK
Fn44	Full Scale Meter Output	1-180Hz	0.1 Hz	60 Hz	***
Fn45	Meter Output Calibration	0-250	1	5	***
Fn46	Multi-input 1	0: SP1 1: Accel #2/ Decel #2 Enable 2: Accel #2/ Decel #2 Stop		0	
Fn47	Multi-input 2	0: SP2 1: Coast to Stop N/O 2: Coast to Stop N/C		0	
Fn48	Multi-input 3	0: SP3 1: Decl. to Stop N/O 2: Decl. to Stop N/C		0	
Fn49	Accel time 2	0.1-800 sec.	0.1 sec.	10 sec.	***
Fn50	Decel time 2	0.1-800 sec.	0.1 sec.	10 sec.	***
Fn51	Display mode	0: Hz 1-4: RPM for motor 5-8: Line speed 9: Motor amps		0	*** **
Fn52	Linear Speed Display	0-9999		1800	***
Fn53	DC Braking time	0.1-25.5 sec.	0.1 sec.	0.5 sec.	
Fn54	DC Braking injection frequency	0-10 Hz 0: Free run to stop	0.1 Hz	2 Hz	
Fn55	DC Braking level	0-20%	0.1%	8% (6)	
Fn56	Baud rate of communication	0: 2400 bps 1: 4800 bps 2: 9600 bps 3: 19200 bps		2	
Fn57	Communication command response mode	0-15		1	
Fn58	Communication transmit object	0-33		0	***
Fn59	Frequency lock select	0: Disable 1: Enable		0	***
Fn60	Parameter lock select	0: Disable 1: Enable		0	***
Fn61	Fault sequence reference	1: XXX, 2: XXX, 3: XXX			
Fn64	CPU version				
Fn65	Prohibited Frequency (1)	0-180 Hz	0.1 Hz	0 Hz	**
Fn66	Prohibited Frequency (2)	0-180 Hz	0.1 Hz	0 Hz	**
Fn67	Prohibited Frequency (3)	0-180 Hz	0.1 Hz	0 Hz	**
Fn68	Prohibited Frequency Range	0-5 Hz	0.1 Hz		**
Fn69	Motor Type	0: Standard Motor 1: Special Motor		0	**
Fn70	Motor Rated Current		0.1A		**
Fn71	Inverter Capacity Select	K1-2110-M3 K1-2150-M3 K1-2220-M3 K1-4110-M3 K1-4150-M3			**

* The factory setting of N1 is 1

** This function is only available on VFK1 2110-2220, 4110-4220 models

*** The setting can be changed in "Run" mode

() Setting of VFK1 2110-2220 and VFK1 4110-4220 only.

Reserved for your notes:

5.2 Function Parameter Setting (effective in program mode)

5.2.1 Changing the Function Parameter





	Key Operation	Description	Digital Operator Display
1	PRGM (Fn)	*Enter program mode *Display the current function code	Fn 0
2	▲ or ▼ keys	*Press up or down keys to select the desired function code.	Fn 2
3	READ ENTER	*Display the current function parameter. *DATA lamp light	DATA 1.00
4	▲ or ▼ keys	*Press up or down keys to change the displayed function parameter data.	DATA 1.00
5	READ ENTER	*Press READ/ENTER to save the displayed function parameter into memory. *DATA lamp goes out *Digital operator displays the current frequency.	End ↓ 0.5 sec. Hz XXXX
6	Repeat steps 1-5	*Changing another function parameter.	
7	STOP	*Function parameter setting procedure ends. *Enter stopping mode. *Digital operator displays the current frequency.	Hz XXXX

∟ ∟ indicates blinking display.

Note: **XXXX** display the current frequency set on **Fn17-23, Fn24, Fn25 (Fn11=0)** or terminal 12-14 (**Fn11=1**). It depends on which frequency mode is in use. The display of the digital operator will blink.

5.2.2 Function Parameter Reference (effective in program mode)

Example: Check frequency reference upper limit (Fn6) & lower limit (Fn7)

	Key Operation	Description	Digital Operator Display
1	PRGM (Fn)	*Enter program mode *Display the current function code	FnXX
2	 or  keys	*Select the Fn6 by pressing up or down keys to select the desired function code.	Fn 6
3	READ ENTER	*Display the parameter of Fn6 *DATA lamp light	 DATA 60.0
4	Repeat steps 1-3	*Display the parameter of Fn7 *DATA lamp lights	 DATA 0.0
5	STOP	*Function parameter reference procedure ends. *Enter stopping mode *Digital operator displays the current	 Hz ·XXXX·

* If function parameters can't be changed and "LOC" is displayed, this means function parameter is locked. Please set Fn59 or Fn60 to 0 to release function parameter lock.

5.3 Function Description

Fn0: Communication ID number (0-32)

Fn0 identify the number of each inverter for RS232 and RS485 communication. Please refer to communication operator manual.

Fn1: Acceleration time 1

Fn2: Deceleration time 1

The set time indicates the interval required before the frequency output reaches the frequency reference upper limit (Fn6). The accel/decel time are effective in digital operator and remote control. The accel/decel time is effective in FWD, REV, Jog and Multi-speed operation and can be set from 0.1 to 800 seconds.

If the inverter is operated in Speed range below the max Frequency. Set by Fn6, the accel/decel times will be reduced proportionately.

Fn3: Remote operation select (effective in remote control Fn10=1)

Inverter offers two methods of remote operation. - FWD/STOP, REV/STOP & FWD/REV, RUN/STOP. Terminal 3 & 8 of TM2 can incorporate with Fn3 to select required remote operation method.

Table 5.1 Remote operation select

Fn10	Operation Mode	Fn3	Operation Method	S 3	S 4	Output
1	Remote Control	0	FWD / STOP REV / STOP	OFF	OFF	STOP
				ON	OFF	FORWARD
				OFF	ON	* REVERSE
				ON	ON	STOP
		1	FWD / REV RUN / STOP	OFF	OFF	STOP
				ON	OFF	FORWARD
				OFF	ON	STOP
				ON	ON	* REVERSE
0	Digital Operator Control	X	X	X	X	X

* Reverse run is allowed when Fn33=0

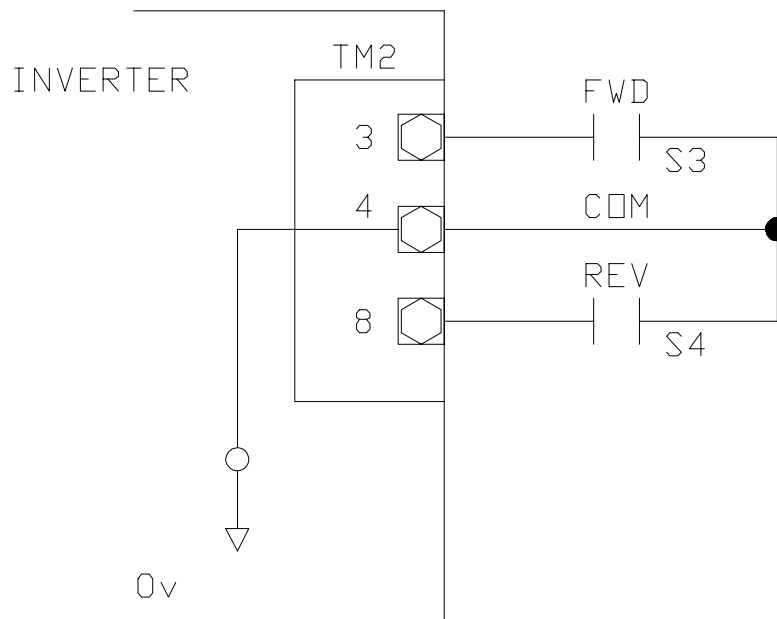

Fig. 5.1a Connection diagram

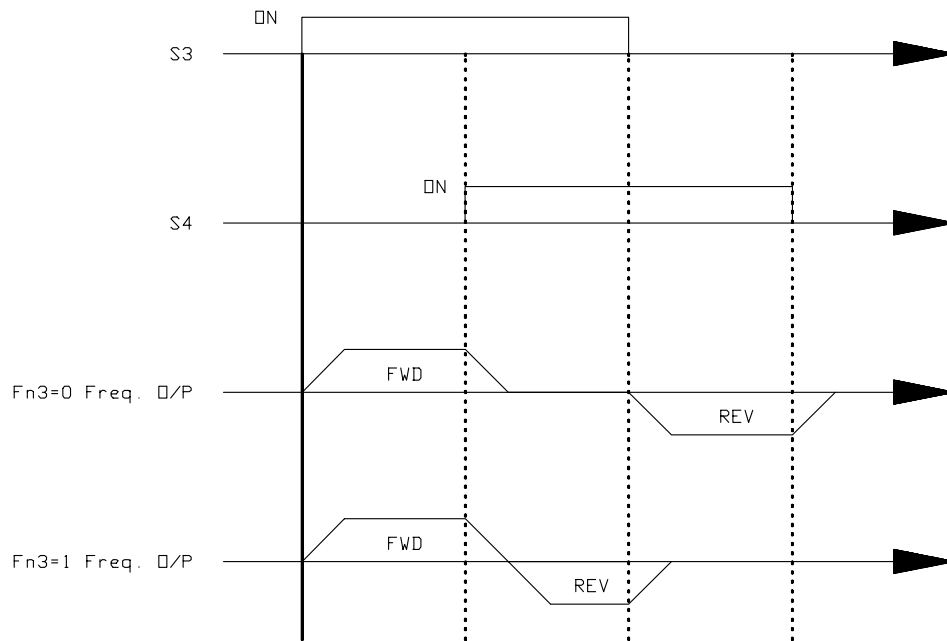

Fig. 5.1b Remote operation example

Fn4: 50/60 Hz ID No. (For VFK1 2110-2220, 4110-4220 only)

Fn4=0 for 50 Hz main supply, Fn5=0 for factory default

Fn4=1 for 60 Hz main supply, Fn5=1 for factory default

Fn5: Voltage/Frequency pattern select

Inverter offers 16V/F patterns for all varieties of applications. **Fn5** determines which pattern is applied. User can design a V/F pattern when **Fn5=15**. (Refer to Fn37-42).

Application notes for choosing optimum V/F pattern.

- * For general purpose operation, set **Fn5=0~3** V/F pattern in Table 5.2
- * For variable torque operation, set **Fn5=4~7** V/F pattern in Table 5.3
- * For high starting torque operation, set **Fn5=8~11** V/F pattern in Table 5.4
- * For contact HP operation, set **Fn5=12~14** V/F pattern in Table 5.5
- * If operation is successful, then setting is satisfactory.
- * If operation is not successful, then try again at another value of the same application reference numbers.
- * If there is no suitable V/F pattern in Table 5.2~5.5, set **Fn5=15**, then design V/F pattern to match the load. (Refer to **Fn37-42**)

Table 5.2 V/F pattern for general purpose

Specifications	Fn5 Reference #	V/F Pattern
50 Hz	0	
60 Hz Saturation	1 15	
50 Hz Saturation	2	
60 Hz	3	

Table 5.3 V/F pattern for variable torque operation (fans & pumps)

Specifications		Fn5 Reference #	V/F Pattern
50 Hz	Variable Torque 1	4	
	Variable Torque 2	5	
60 Hz	Variable Torque 1	6	
	Variable Torque 2	7	

It is generally not recommended to operate fans or pumps above 60Hz.

Table 5.4 V/F pattern for high starting torque

Specifications		Fn5 Reference #	V/F Pattern
50 Hz	Starting Torque Low	11	
	Starting Torque High	12	
60 Hz	Starting Torque Low	13	
	Starting Torque High	14	

Table 5.5 V/F pattern for constant HP operation (machine tools)

Specifications	Fn5 Reference #	V/F Pattern
60 Hz	12	
60 Hz	13	
60 Hz	14	

Fn5	A		B		C	
0	100%	50 Hz	7.5%	2.5 Hz	7.5% (4.4)	1.0 Hz
1		60 Hz		3.0 Hz	7.5% (4.2)	
2		50 Hz		3.6 Hz	7.5% (3.9)	
3		60 Hz		17.5%	25 Hz	
4		50 Hz	25%	7.5% (4.7)		
5		60 Hz	17.5%	30 Hz	7.5% (3.8)	
6			25%		7.5% (4.6)	
7		50 Hz	9%	2.5 Hz	7.5% (5.3)	
8			11.5%		7.5% (5.9)	
9			9%	3.0 Hz	7.5% (5.7)	
10		11.5%	8.2%			
11		60 Hz	7.5%	4.5 Hz	7.5% (3.5)	
12			17.5%	6.0 Hz	7.5% (3.3)	
13			15%		7.5% (7.0)	
14						

() factory setting of VFK1 models 2110-2220, 4110-4220

* Example **Fn5=0**

When input voltage is 220VAC, the voltage of points A, B, C are:

A: $220 \times 100\% = 220V$

B: $220 \times 7.5\% = 16.5V$

C: $220 \times 7.5\% = 16.5V$

Fn6: Frequency output upper limit (setting range: 1-180Hz)

Fn7: Frequency output lower limit (setting range: 0-180Hz)

The frequency output will be limited between the upper and lower limits. Operation at the lower limit setpoint **Fn7** begins immediately when "run" command is input.

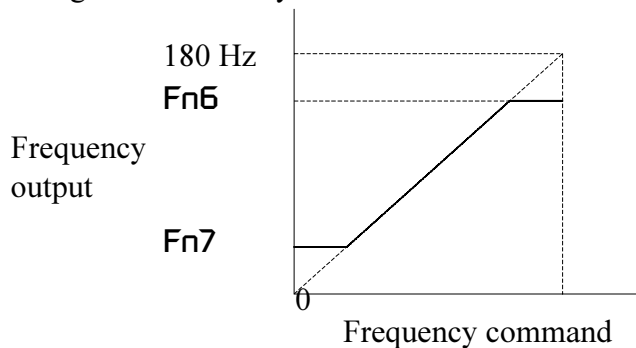

Fig. 5.2 Frequency Output Upper & Lower Limit

Important!

If **Fn7=0** Hz, inverter output will be stopped immediately if frequency command is set to 0 Hz.

If **Fn7>0** Hz, inverter output will run at the frequency of **Fn7** if frequency command is lower than the frequency of **Fn7**.

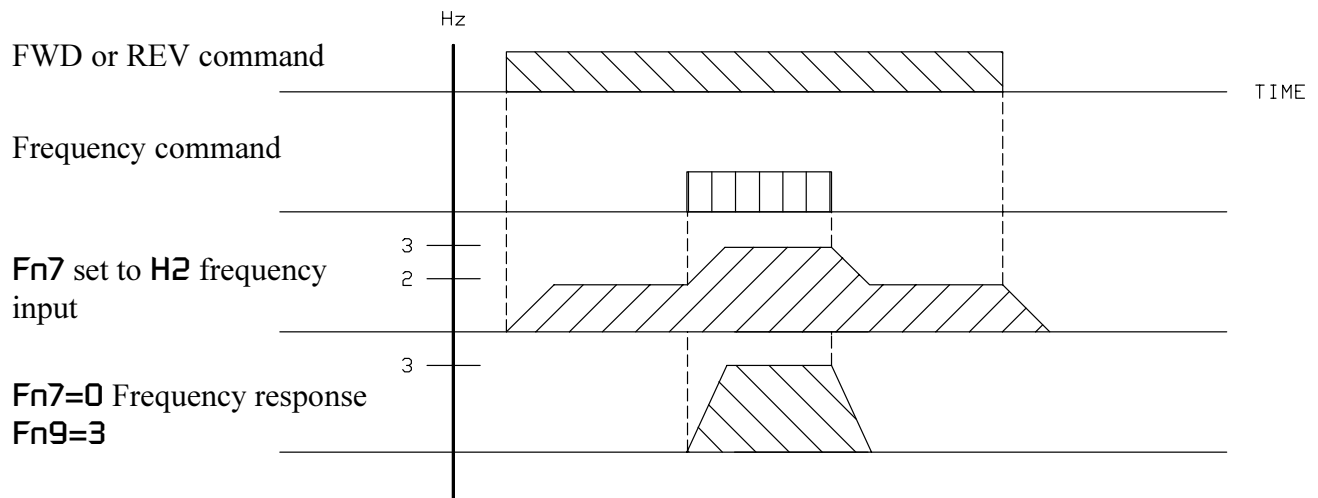

Fig. 5.3 Zero speed stop.

Fn8: Multi-function output

Terminal 10 of TM2 is an open collector output, its level will be switched from high to low when **Fn8** is set as described below:

Fn8=0: Enters "RUN" mode.

Fn8=1: Running at constant frequency.

Fn8=2: Frequency output is greater than or equal to setting of **Fn9**.
(Please refer to section 4,3,5 for details)

Fn9: Set frequency. (setting range: 1-180Hz)
(Please refer to **Fn8** for details)

Fn10: Control method select

Fn10=0: Inverter is operated by: FWD, REV, STOP keys on digital operator. SEQ LED is off.

Fn10=1: Inverter is operated by remote control switches (FWD, REV) through TM2, SEQ LED is on. (Please refer to table 5.1)

Fn11: Frequency command method select.

Fn11=0: Frequency output is set by digital operator interface. FRQ LED is off. Frequency is set in **Fn25** or changed by press up and down arrow keys. (effective when **Fn59=0**)

Fn11=1: Frequency output is set by external 10K ohm variable resistor or 0-10V, 1-5V, 4-20mA analog signals. FRQ LED lights. (Please refer to **Fn26-30** and jumper 2.)

Fn12: Motor stall prevention during acceleration and deceleration (0 and 110%-200%)

Applicable only to VFK1 2110-2220 and VFK1 4110-4220.

Fn12=0: Stall prevention is disabled.

CAUTION: It is suggested to disable this function in applications where acceleration or deceleration time must be maintained at preset times. ie: lifting or lowering machines.

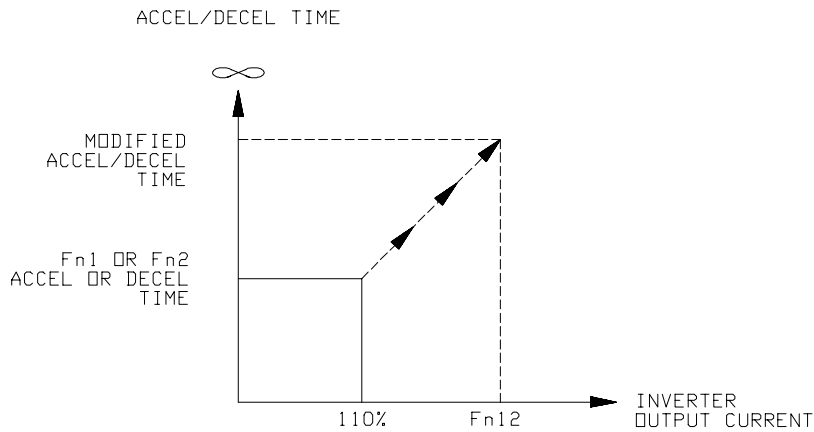

Fig. 5.4 Fn12 example

Fn13: Fault relay preset

Fn13=0: Fault relay is preset normally open. (N/O)

Fn13=1: Fault relay is preset normally closed. (N/C)

When inverter is without power, contact is normally open. (N/O)

Fn14: Reset (effective in both digital operator and remote control operation. Fn10=0 or Fn10=1)

If **Fn14** is disabled, inverter can't be reset via digital operator reset key or reset switch. (Terminal 11) of TM2 unless stop command is input.

Fn14=0: Reset is invalid unless inverter is stopped.

Fn14=1: Reset is effective.

Note: Important!

If the application condition allows, it is strongly recommended to disable this function to prevent injury to personnel and equipment damage.

Fn15: Stall trip prevention. (This function is only available on inverter models VFK/N1 204-275, 407-475.

Inverter will extend the accel/decel time automatically if the current increases over 180% rating.

CAUTION: It is suggested to disable this function if the application must maintain the preset acceleration or deceleration time. ie: lifting or lowering machine.

When **Fn15=**

1: Stall prevention is disabled.

2-8: Stall prevention enabled. Inverter will extend the accel./decel. time automatically to 2-8 times. When the situation of stall disappears, inverter will accel rate to the preset frequency or deceleration rate to 0 with previous speed.

Fn16: Direct start prohibit. (effective in remote control only, Fn10=1)

If this function is enabled, inverter will not start immediately after power switched on. Inverter must acknowledge the lack of run command first.

Note: Important! If the application condition allows, it is strongly recommended to enable this function to prevent injury to personnel and equipment damage.

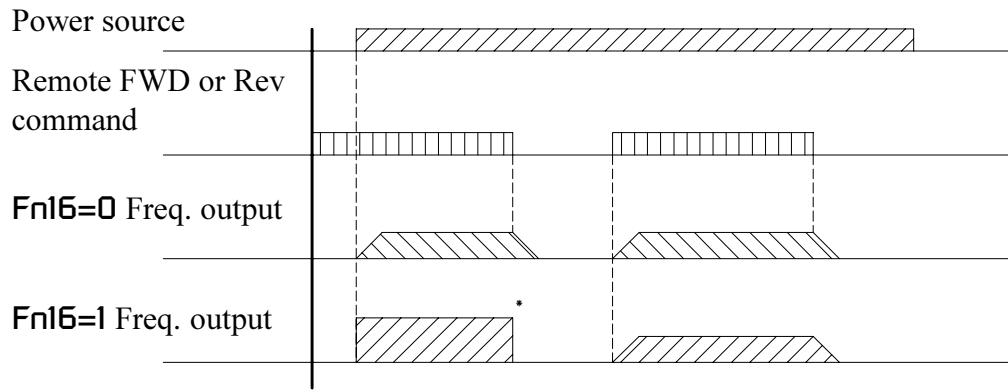

Table 5.4 Priority of running command.

Note: * Inverter's output is OFF and display is blinking "STP1" until stop command is given or RESET key is pressed.

- Fn17: Multi-speed frequency reference number 1**
- Fn18: Multi-speed frequency reference number 2**
- Fn19: Multi-speed frequency reference number 3**
- Fn20: Multi-speed frequency reference number 4**
- Fn21: Multi-speed frequency reference number 5**
- Fn22: Multi-speed frequency reference number 6**
- Fn23: Multi-speed frequency reference number 7**

Note: * Fn17-23 are effective in both remote command mode and digital operator control mode. Multi-speed frequencies can be changed by pressing the up or down arrow keys directly, without the need to set the function code to Fn17-23 when inverter is in multi-speed operation.

* The range of Fn17-23 is set from 0 to 180Hz
(Please refer to section 4.3.4 for details)

Table 5.6 Multi-speed operation.

SP1	SP2	SP3	Inverter frequency output	Reference
OFF	OFF	OFF	Set by external signal or digital operator control	2
ON	OFF	OFF	Frequency set by Fn17	3
OFF	ON	OFF	Frequency set by Fn18	4
ON	ON	OFF	Frequency set by Fn19	5
OFF	OFF	ON	Frequency set by Fn20	6
ON	OFF	ON	Frequency set by Fn21	7
OFF	ON	ON	Frequency set by Fn22	8
ON	ON	ON	Frequency set by Fn23	9

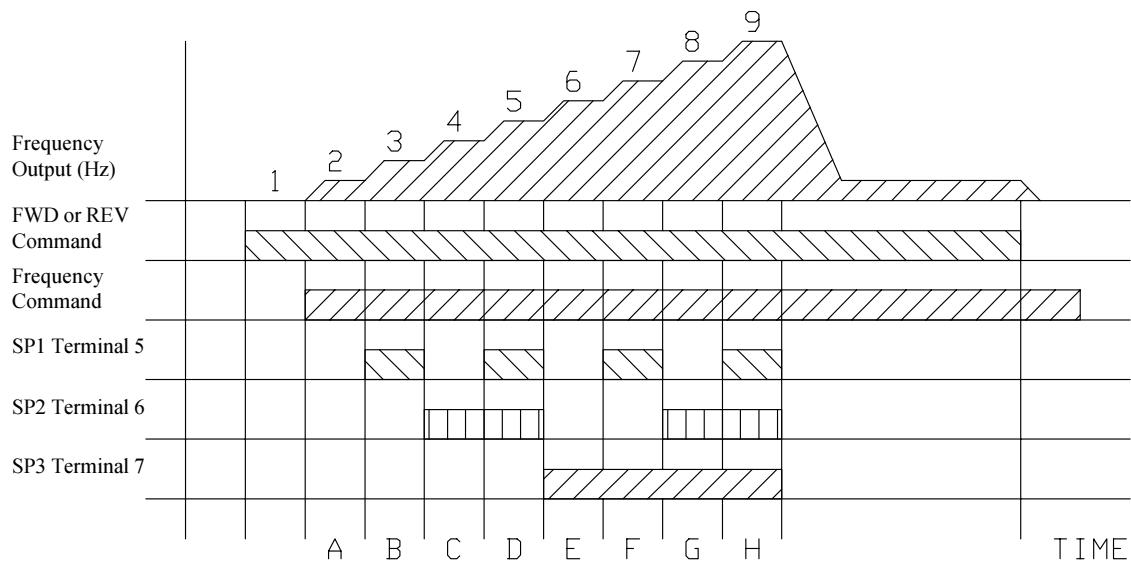
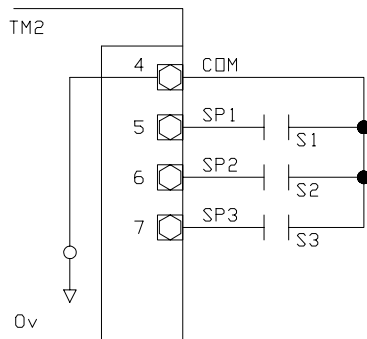

Fig. 5.5 Multispeed operation



Fn24: Jog Frequency Reference (0-180Hz)

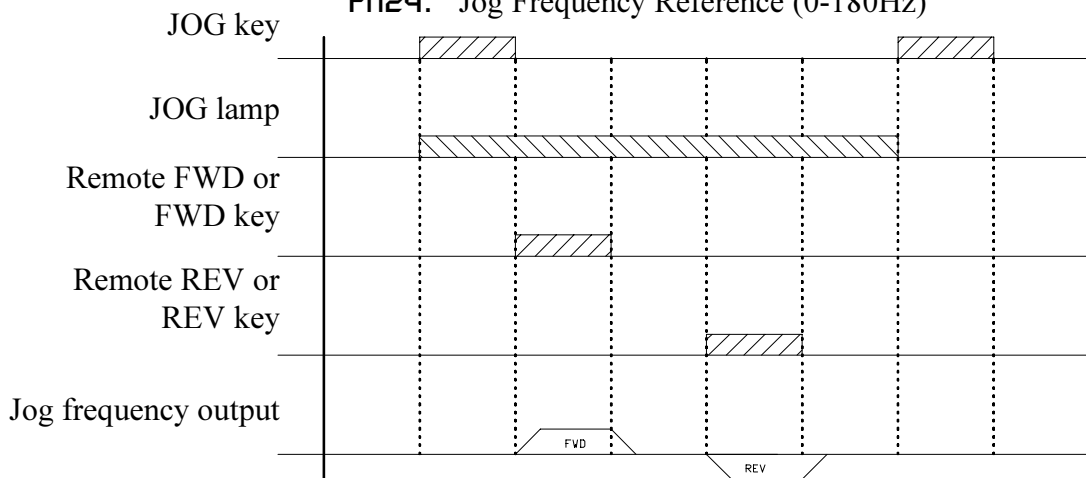

Fig. 5.6 Jog operation in digital operator control

Note:

- * Jog operation is effective in both digital operator or remote control.
- * In "stop" mode, jog command is effective; in "run" mode, jog command is ineffective.
- * The jog frequency can be changed when inverter is in jog operation by pressing up or down keys directly, without the need to set the function code to **Fn24**.

* In jog operation, absence of FWD or REV command will cause inverter to STOP. Inverter will free run or brake to stop.

Fn25: Master frequency reference.

Master frequency reference is used in digital operator control (Fn11=0)

Note: * The master frequency can be changed when inverter is in run operation without the need to set the function code to Fn25.

Priority of Frequency Operation Mode

There are three frequency operation modes and the priority of each is as follows:

1. Jog mode (Fn24)
2. Multi-speed frequency mode (Fn17-23)
3. Master frequency mode (Fn25, when Fn11=0; Terminal 12-14, when Fn11=1)

Example:

When JOG key is pressed, inverter will run in jog mode no matter which frequency mode is in use. If JOG key is pressed again, inverter will return to last frequency mode. Also, if inverter is running in master frequency mode, frequency can be changed to multi-speed operation by turning on SP1 (or SP2, SP3). Refer to Fn17-25.

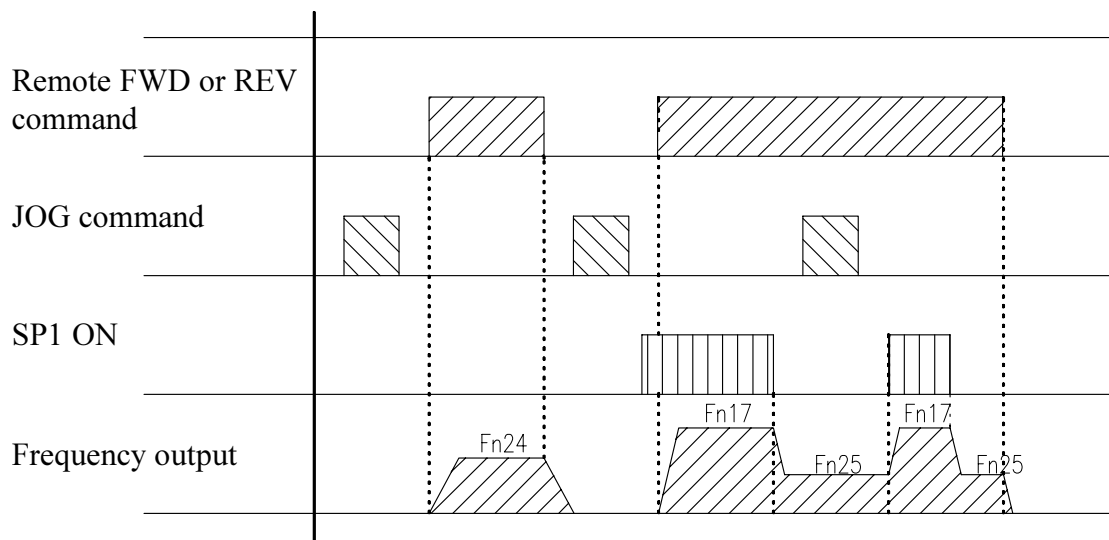

Fig. 5.7 Priority of frequency operation
 Note: * In "run" mode, jog command is ineffective.

Fn26: BIAS of frequency reference.

Positive or negative frequency offset magnitude at starting point.

Fn27: Positive / Negative BIAS

Fn27=0: Positive Bias of frequency reference.

Fn27=1: Negative Bias of frequency reference.

Fn28: Output frequency set by full frequency reference.

Fn26-28 are used to customize the remote frequency command (speed reference) to obtain the desired inverter frequency output.

The BIAS (**Fn26**), polarity (**Fn27**) and maximum frequency output (**Fn28**) of the remote frequency command are as follows:

Curve	Fn26	Fn27	Fn28
A	Any value	0	0-180 Hz
B	0	0	
C	Obtain from formula	1	

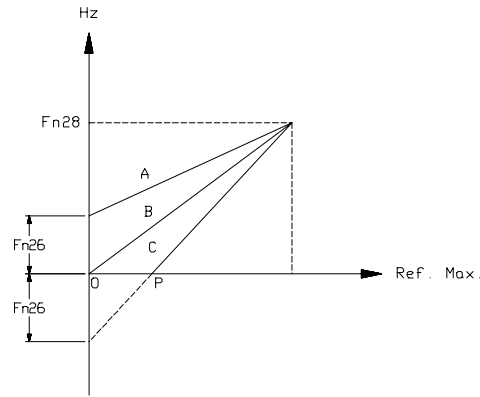

Example of operation shown by line A.

Set **Fn26**= minimum frequency output when the speed reference is zero.
 Set **Fn27**=0
 Set **Fn28**= maximum frequency when the speed reference is at maximum.

Example of operation shown by line B.

Set **Fn26**=0
 Set **Fn27**=0
 Set **Fn28**= maximum frequency when the speed reference is at maximum.

Example of operation shown by line C.

$$\text{Set } \mathbf{Fn26} = \mathbf{Fn28} \times \frac{\mathbf{P}}{\text{Ref. max.} - \mathbf{P}}$$

Where **Fn28** is the maximum frequency when the speed reference is at maximum.
 P is the value of speed reference where output frequency is zero.
 Reference maximum is the maximum speed reference. (refer to setting of **Fn28** above)

EXAMPLE:

Speed range required 0-50Hz with a 4-20mA signal. What are the values for **Fn26**, **Fn27** and **Fn28**.

Fn28=50Hz (maximum frequency with maximum speed reference)

Fn27=1

$$\mathbf{Fn26} = \mathbf{Fn28} \times \frac{\mathbf{P}}{\text{Ref. max.} - \mathbf{P}}$$

P=4: Speed reference where output frequency is zero.
 Reference maximum = 20: Maximum speed reference.

$$Fn26 = 50 \times \frac{4}{20-4} = \frac{50}{4}$$

$$Fn26=12.5$$

Therefore, if inverter is required to operate from 0-50Hz with a 4-20mA signal $Fn26=12.5Hz$, $Fn27=1$ and $Fn28=50Hz$.

Fn29: Remote frequency command reverse signal select (Fn11=1)

Jumper 1, 2 (refer to 4.4), $Fn29$ & $Fn30$ used to select 0-10V, 1-5V & 4-20mA (direct or reverse) remote control frequency command signal.

$Fn29=0$: Direct proportion signal

$Fn29=1$: Reverse proportion signal

Fn30: Remote frequency command select (Fn11=1)

$Fn30=0$: 1-5, 4-20mA analog signal

$Fn30=1$: 0-10V analog signal

Table 5.7 Remote frequency command select via $Fn29$ & $Fn30$

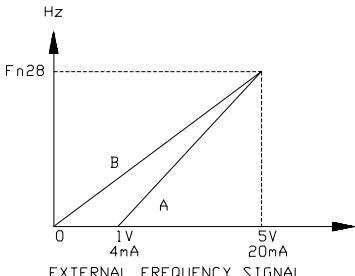
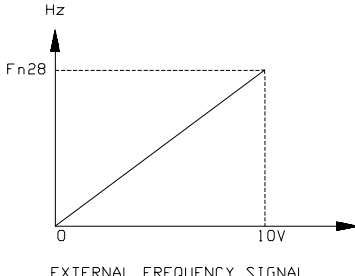
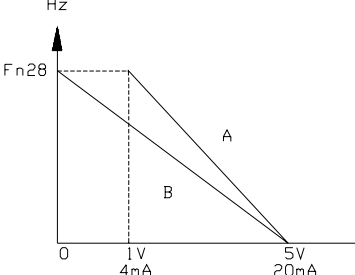
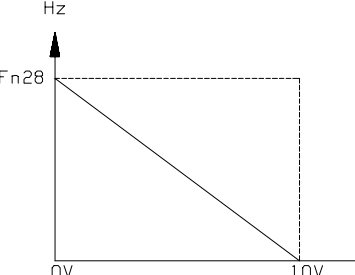
$Fn30$ $Fn29$	0	1
0		
1		

Fn31: Constant speed stall trip prevention or constant speed stall trip prevention enable level (0-160% rated current) for VFK1 2110-2220, VFK1 4110-4220 enable frequency (1-180Hz) for VFK/N1 204-275 and VFK1 407-475 models. Please refer to $Fn32$ for details.

F_n32: Constant speed stall trip prevention deceleration time (0.1-800 sec.)

When inverter runs in constant speed, if the current increases over 90% of OC level (VFK/N 204-275 and VFK/N 407-475) or over **F_n31** enable level (VFK 2110-2220 and VFK 4110-4220), and output frequency exceeds the frequency of **F_n31** (for VFK/N 204-275 and VFK/N 407-475 only, there is no such limit for VFK 2110-2220 and VFK 4110-4220) Inverter will decelerate to prevent trip. **F_n32** is used to set the deceleration time.

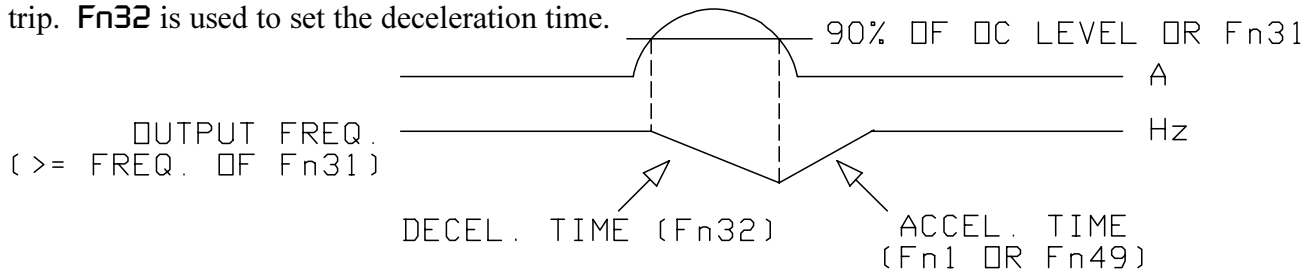

Fig. 5.8 Constant speed stall prevention

F_n33: Reverse run prohibit.

Reverse run is prohibited if this function is enabled.

F_n33=0: Forward and reverse run are allowed.

F_n33=1: Reverse run is prohibited.

F_n34: Auto restart interval (0-800 sec.)

Refer to **F_n35** for operation details.

F_n35: Auto restart times (0-10 times)

F_n34 and **F_n35** are used for auto restart. Two separate methods of operation are available.

1. "SPEED SEARCH" **F_n34=0, F_n35=1-10**

The inverter will attempt a restart 0.5 sec. after a trip caused by any of the following protection functions: OC-A, OC-C, OV-C, LV-C, OH-C.

The inverter will match the speed of the tripped motor - that is "Speed search" then accelerate the motor to the preset speed reference.

F_n35 sets the number of restart attempts and can be set to 1-10 times.

2. "AUTO RESTART" **F_n34 >= motor coast stop time, F_n35: 1-10**

The inverter will attempt a restart after a trip caused by the above protection functions after a time interval set by **F_n34**. **F_n34** must be set at a time greater than the motor takes to coast (free run) to a stop with load inverter.

F_n35 sets the number of restart attempts and can be set to 1-10 times.

NOTE:

* Auto restart and speed search is effective whether **F_n10=0** or **1**.

* Auto restart is ineffective when a trip occurs while the motor is decelerating or braking to a stop.

* Auto restart and speed search times - **F_n35** will be reset when:

(i) Inverter operates trip free for 10 minutes.

(ii) "Reset" command is input, either from remote terminal (terminal 11) or digital operator.

(iii) When the inverter is stopped.

F_n36: Scan times (0000-9999)

The times inverter scans the input signal before responding.

The left two digits= The times inverter scans the status of on/off switches (terminal 3, 5, 6, 7, 8, 11 of TM2) before responding. For instance, when these two digits are set to 10, inverter will respond only if results of 10 successive scans are the same.

The right two digits= The times inverter scans the analog frequency command (terminal 13 of TM2) before responding. For instance, when these two digits are set to 03, inverter will respond only if results of 3 successive scans are the same. For VFK1 2110-2220 and VFK1 4110-4220 inverters, the inverter scans the analog frequency command (terminal 13 of TM2) and responds to the average of 10 times the right two digits. For example, when these two digits are set to 07, inverter will respond to the average of $7 \times 10 = 70$ scans.

Note:

- * Unit scan time of inverter: 2 ms
- * When **F_n36=0**, inverter will respond after each scan.

CAUTION: Important!

This function will extend or shorten the response time of inverter. Except for some applications requiring fast response time, we recommended not to change the factory setting to secure high electrical noise immunity level.

For N1 series and K1 series (VFK1 204-275 and VFK1 407-475) inverters, if **RESET** and **ENTER** keys are pressed simultaneously, **F_n36** will be set to **1007**. To secure inverter correction operation, we recommend to change **1007** back to the original setting **1001**.

F_n37: Maximum frequency (50-180Hz)

F_n38: Maximum voltage ratio (0-100%)

F_n39: Mid. frequency (1-180Hz)

F_n40: Mid. voltage ratio (0-100%)

F_n41: Minimum frequency (1-180Hz)

F_n42: Minimum voltage (0-100%)

F_n37-42 are used to design the most suitable V/F pattern for application conditions. (**F_n5=15** only)

Example:

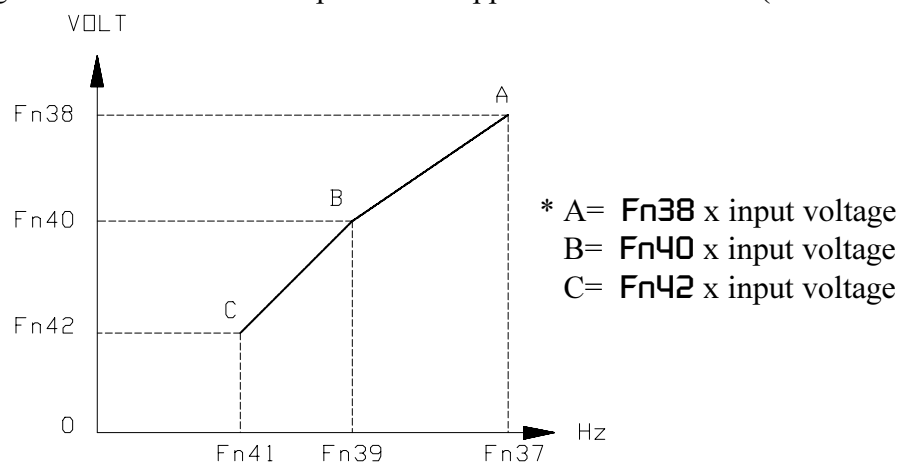

Fig. 5.9 V/F pattern designed by user.

* Regulation: $F_{n37} > F_{n39} > F_{n41}$, $F_{n38} \geq F_{n40} \geq F_{n42}$
 $\frac{F_{n38}-F_{n40}}{F_{n37}-F_{n39}} \leq 65$ $\frac{F_{n40}-F_{n42}}{F_{n39}-F_{n41}} \leq 65$

F_{n43}: Carrier frequency (1440-3600Hz)

When the inverter output causes irregular motor noise, a different carrier frequency may be set by **F_{n43}**.

F_{n44}: Full scale meter output (1-180Hz)

The output frequency scale of terminal 16 can be set in the range of 1-180Hz by using this function. The method is the same as **F_{n28}**. Which one of the following figures is dependent on what kind of meter is used.

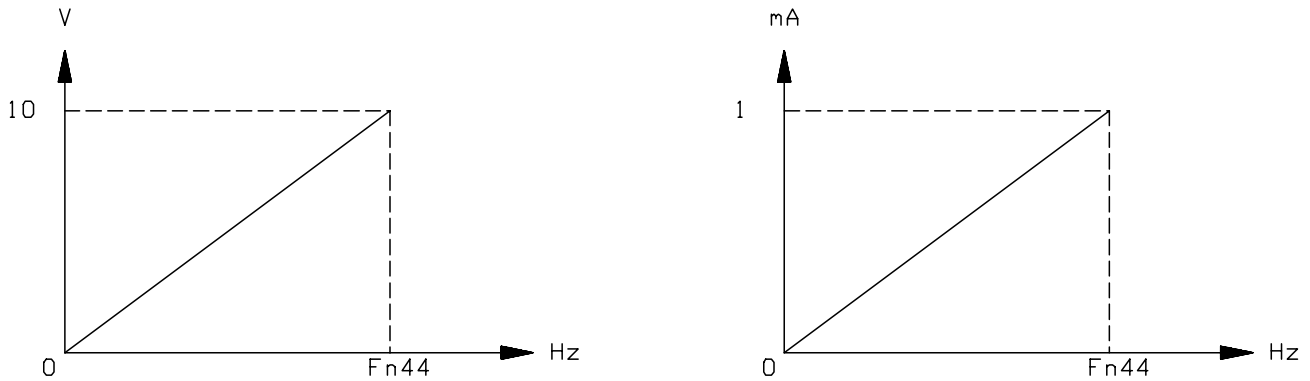

Fig. 5.10 Full scale D/A output

F_{n45}: Meter output calibration (0-250)

When **F_{n44}** is set, output errors may occur. **F_{n45}** is used to calibrate the output. Setting range 0-250. Refer to fig. 5.11.

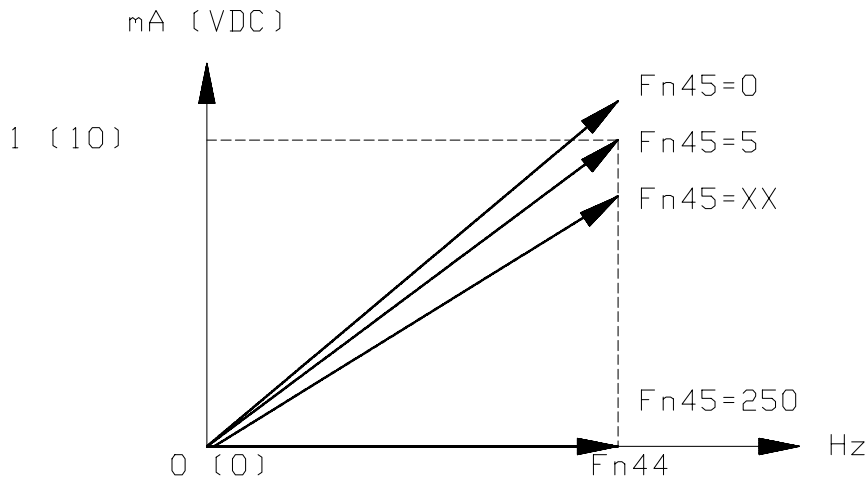

Fig. 5.11

F_n46: Multi-input 1

F_n46=0: Terminal 5 (SP1) is used for multi-speed operation (Please refer to 4.3.4)

F_n46=1: When SP1 is closed, F_n46 initiates the second accel / decel time set by F_n49 and F_n50.
(Please refer to Fig. 5.12 & F_n49, F_n50)

F_n46=2: When SP1 is closed F_n46 stops automatic acceleration/deceleration. (Please refer to Fig. 5.13)

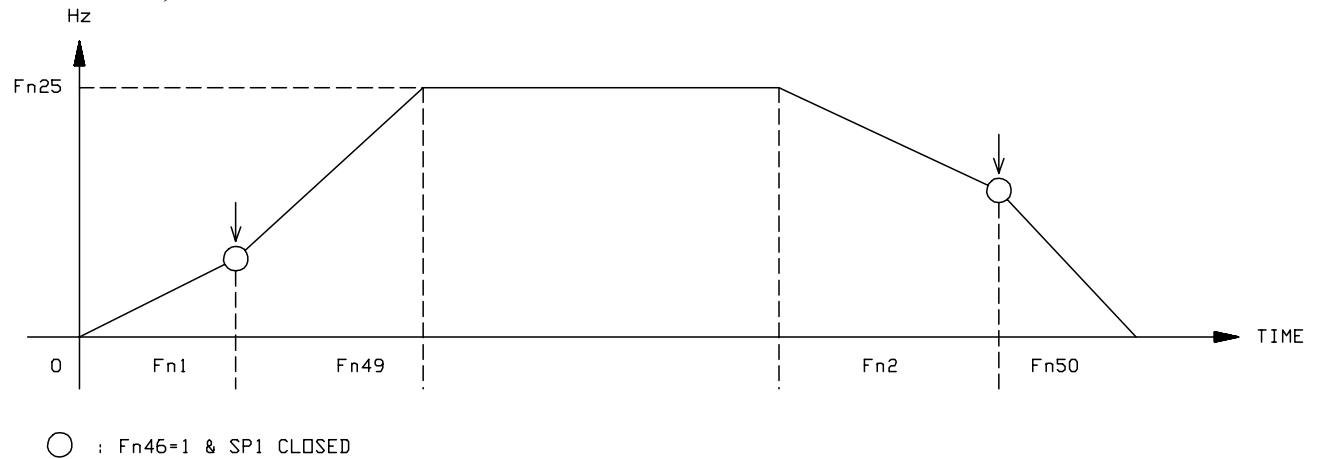

Fig. 5.12 The secondary acceleration and deceleration

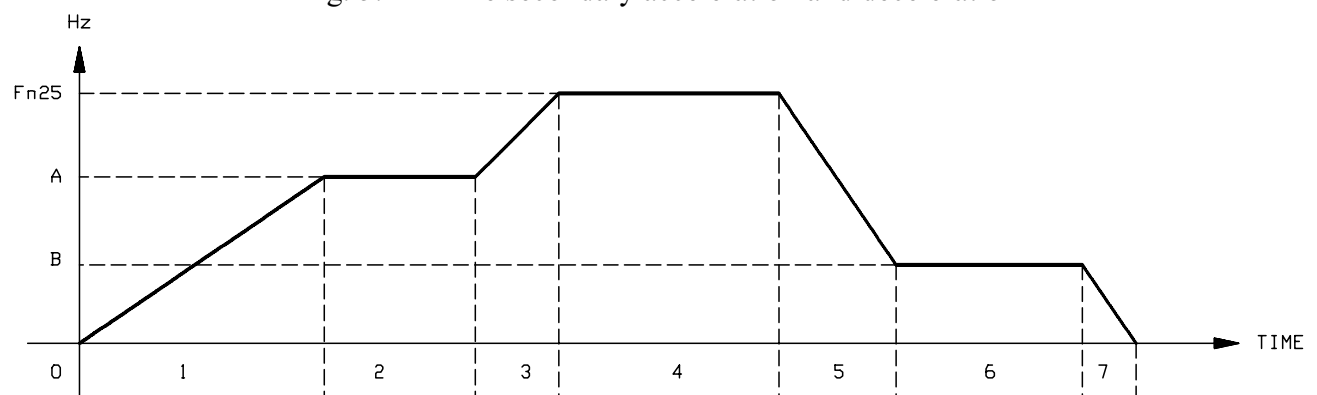

Fig. 5.13 Stop acceleration / deceleration in remote control mode

Time 2: F_n46=2 & SP1 is closed, inverter stops accelerating and runs at constant speed A.

Time 3: SP1 is open, inverter continues to accelerate to frequency of F_n25. The intervals of Time 1 & Time 3 are equal to the accel. time set on F_n1.

Time 4: Inverter runs at constant speed set on F_n25.

Time 5: Inverter decelerates.

Time 6: F_n46=2 & SP1 is closed, inverter stops decelerating and runs at constant speed B.

Time 7: SP1 is open, inverter continues to decelerate to the frequency of lower limit. The intervals of Time 5 & Time 7 are equal to the decel time set on F_n2.

Fn47: Multi-input 2

Fn47=0: Terminal 6 (SP2) is used to for multi-speed operation.

Fn47=1: When SP2 is closed, inverter is base blocked. When SP2 is open, inverter will restart from 1 Hz.

Fn47=2: When SP2 is open, inverter will be base blocked. When SP2 is closed, inverter will restart. (When inverter is baseblocked, motor is in free run mode.)

Note: * **Fn47=1, 2** is effective no matter **Fn10=0** or 1.

Fn48: Multi-input 3

Fn48=0: Terminal 7 (SP3) is used for multi-speed operation.

Fn48=1: When SP3 is closed, inverter will decelerate to stop. When SP3 is closed inverter will restart from 1Hz.

Fn48=2: When SP3 is open, inverter will decelerate to stop. When SP3 is closed inverter will restart. (The deceleration time is as the same as **Fn2** or **Fn50**, it depends on which deceleration time is used.)

Note: * **Fn48=1, 2** is effective no matter **Fn10=0** or 1.

* Inverter will free run to stop, if **Fn54=0**.

Fn49: Acceleration time 2 (0.1-800 sec.)

The operation method is as the same as **Fn1**. (Please refer to **Fn46**)

Fn50: Deceleration time 2 (0.1-800 sec.)

The operation method is the same as **Fn2**. (Please refer to **Fn46**)

Fn51: Display mode select

Fn51=0: Inverter displays output frequency (Hz)

Fn51=1-4: Inverter displays the motor shaft speed in rpm according to the formula below:
RPM=120 x inverter output frequency / motor pole.

Fn51=1: for 2 pole motor.

Fn51=2: for 4 pole motor.

Fn51=3: for 6 pole motor.

Fn51=4: for 8 pole motor.

Fn51=5-8: Inverter displays content of **Fn52** with seven segment display arranged as:

Fn51=5: XXXX

Fn51=6: XXX.X

Fn51=7: XX.XX

Fn51=8: X.XXX

Fn51=9: Inverter display of motor amp draw (only available on VFK1-2110~2220 and VFK1-4110~4220)

Fn52: Linear speed display (effective when Fn51=5-8)

Fn52 defines the linear relationship between **Fn52** and **Fn6** (upper limit).

For instance, set **Fn6=60** Hz and **Fn52=1,800**. **Fn52** will be **1,800** when inverter output freq. = 60 Hz. Because of the linear relationship, **Fn52** will be **900** when inverter output frequency = 30Hz.

Fn53: DC braking time (unit 0.1 sec.)

Setting range 0-25.5 sec.

DC braking injection can prevent overrun of motor at end of deceleration.

Select proper time according to the load condition. Extend the injection time if motor is rotating with a high inertial load.

Fn54: DC braking injection frequency (unit 0.1 Hz)

Fn54=0: Inverter turns off after deceleration

Fn54=1-10: 1-10Hz (unit 0.1 Hz), DC braking will be enabled when output frequency of inverter \leq Hz setting of **Fn54**.

Fn55: DC braking level

Fn55 defines the percentage of DC injection braking voltage to the full input voltage.

For example, set **Fn53=0.5**, **Fn54=2**, **Fn55=8** (input voltage=220V) DC braking will start when inverter decelerates, to 2Hz (**Fn54**) and inject 17.6 VDC (220 x 8%, **Fn55**) for 0.5 sec. (**Fn53**).

Fn56: Baud rate of communication. Please refer to communication operation manual.

Fn56=0: 2400 bps

Fn56=1: 4800 bps

Fn56=2: 9600 bps (Factory setting)

Fn56=3: 19200 bps

Fn57: Communication command response mode. Please refer to communication operation manual.

Fn58: Communication transmit object. Please refer to communication operation manual.

Fn59: Frequency lock select.

Frequency of **Fn17-25** cannot be changed if frequency lock is selected.

Table 5.7 Frequency lock select

	Fn59=0	Fn59=1
Fn11=0	Adjustable	Locked
Fn11=1	Adjustable	In "stop" mode: adjustable in remote operation only. In "run" mode: locked

F_n60: Parameter lock select

Function parameters of **F_n0-16 & F_n26-58** cannot be changed if **F_n60** is enabled.

F_n60=0: Function parameters can be read and written to and from memory.

F_n60=1: Function parameters can be read only from memory.

F_n61: Fault sequence reference

In order to simplify troubleshooting, inverter memorizes the last three fault codes automatically in its EEPROM memory. Press up and down keys on the digital operator to refer to the faults recorded.

For instance:

1.-- : No fault condition (only two faults occurred)

2.OCd : The second fault code. Over current during deceleration

3.LU-C : The third fault code (the latest one) is low voltage.

F_n64: CPU version.

LED display shows EPROM memory version.

F_n65-F_n68: Resonant frequency jump control.

F_n65: Prohibited frequency 1 0-180Hz

F_n66: Prohibited frequency 2 0-180Hz

F_n67: Prohibited frequency 3 0-180Hz

F_n68: Prohibited frequency range 0-5Hz

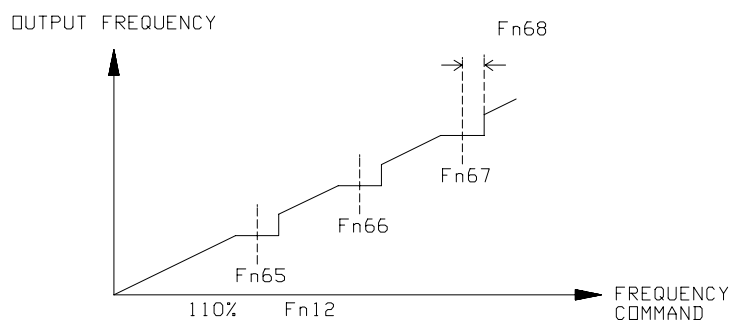

Fig. 5.14

F_n69: Motor selection

F_n69=0: Electronic thermal characteristics are in accordance with standard motor.

F_n69=1: Electronic thermal characteristics are in accordance with special motor.

Note: Only available on VFK1 2110-2220, VFK1 4110-4220.

F_n70: Selection of motor rated current

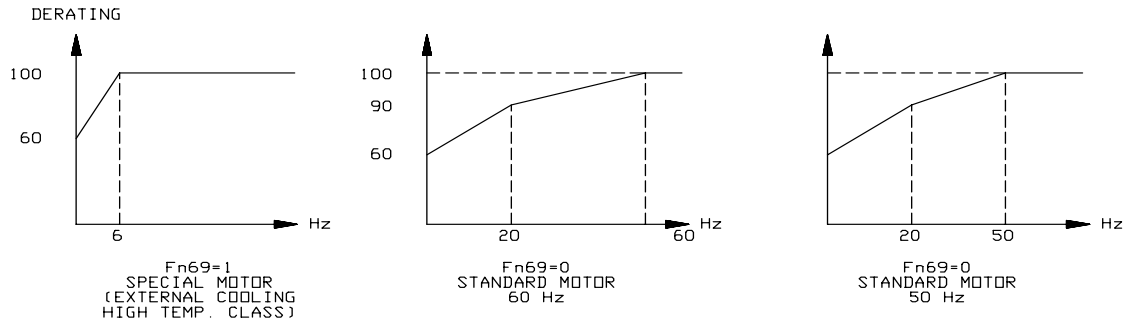

Note: The following diagram can only be applied to the operation under rated speed. For low speed operation, the ratio should be multiplied by the derating rate in the above diagram.

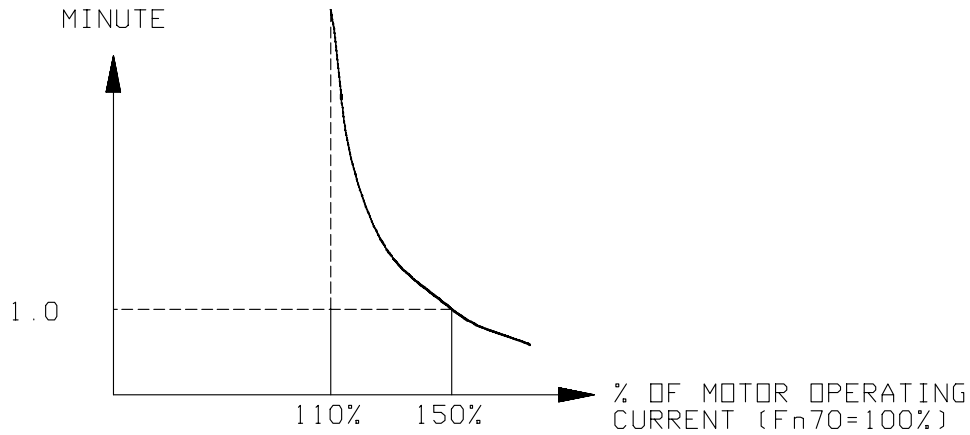

Note: This function is only available on VFK1 2110-2220, VFK1 4110-4220

F_n71: Inverter capacity selection

F_n71=1: K1-2110

F_n71=2: K1-2150

F_n71=3: K1-2220

F_n71=4: K1-4110

F_n71=5: K1-4150

F_n71=6: K1-4220

Note: This function is only available on VFK1 2110-2220, VFK1 4110-4220.

DIFFERENCES BETWEEN K1 SERIES 207-275, 407-475 and 2110-2220, 4110-4220

Item	Description	Models 207-275, 407-475	Models 2110-2220, 4110-4220
1	Ground fault protection	ZCT is required, connect the ZCT at the CON4 of PCB.	ZCT is not required, the function is built in. CON4 is not available on the PCB.
2	Current display	N/A	Set Fn51 to 9 then keypad can display the output current. (Hz & data will not be available)
3	Fn12 (accel./decel current stall prevention level)	N/A	Please see page 37
4	Fn15 (Stall prevention)	Inverter will extend the accel./decel time 1-8 times automatically if the current increases over 180%.	N/A
5	Setting for Fn1, Fn2, Fn32, Fn49 & Fn50	Fn1, Fn2=5 sec. Fn32=0.8 sec. Fn49, Fn50=10 sec.	Fn1, Fn2=10, Fn32=3, Fn49 & Fn50=20 sec.
6	The factory setting of Fn55 (DC braking level)	8%	6%
7	Fn64 (CPU version)	V1.0	V3.0
8	The freq. signal process method of point 13 on tm2	Please refer to page 45 of the manual.	Please see page 45 of this manual
9	Fault code of the electronic motor thermal overload	N/A	OL-C
10	Fn65-Fn68 skip frequency	N/A	Please see page 50
11	Fn69 (motor selection) Fn70 (motor rated current) Fn71 (inverter model)	N/A	1. Select motor capacity. 2. Fn70 & Fn71 have been set by factory based on the table shown on page 51. 3. Fn70 & Fn71 will not be reset if users try to reset all settings back to factory settings.
12	Hunting control	N/A	Anti- vibration (built in).

ITEM 11:

Setting	Model	2110-M3	2150-M3	2220-M3	4110-M3	4150-M3	4220-M3
Fn70		39.7	53.0	77.2	20.1	26.7	38.5 Amp.
Fn71		1	2	3	4	5	6

5.4 Special Function Setting

5.4.1 Return to factory default parameters (effective in stop mode only)

Table 5.8 Return to factory setting.

Key Operation	Description	Digital Operator Display
Press RESET & READ key at ENTER the same time	Return all the function parameters to default setting, including parameter lock Fn59, freq. lock Fn60 & fault sequence reference Fn61.	<pre> rES ↓ [] 0.5 sec. \XXXX/ </pre>

\ / indicates flashing display.

5.4.2 Fault sequence reference & clearing of fault codes. (effective in program mode only)

Table 5.9 Fault sequence reference & clearing of fault codes

Key operation	Description	Digital Operator Display
1. <input type="button" value="FUN"/>	* Enter program code * Display the current function code	FnXX
2. <input type="button" value="^"/> or <input type="button" value="v"/> keys	* Select the Fn61 by pressing up and down keys	Fn61
3. <input type="button" value="READ"/> <input type="button" value="ENTER"/>	* Refer to the first fault code * DATA lamp lights	<input type="checkbox"/> DATA 1XXX
4. up key <input type="button" value="^"/>	* Refer to the second fault code * DATA lamp lights	<input type="checkbox"/> DATA 2XXX
5. down key <input type="button" value="v"/>	* Refer to the third fault code * DATA lamp lights	<input type="checkbox"/> DATA 3XXX
6. <input type="button" value="RESET"/>	* Clear fault sequence memory * Enter stopping mode * Digital operator displays the current frequency	<input type="checkbox"/> Hz XXXX
7. <input type="button" value="STOP"/>	* Enter idle mode * Digital operator displays the current frequency	<input type="checkbox"/> Hz XX.XX

∖ √ indicates flashing display.

5.4.3 Emergency stop via digital operator in remote control mode

Inverter will be stopped via remote switches if it is in remote control (Fn10=1), but inverter can also be stopped by pressing "STOP" and "REV" keys simultaneously on the digital operator in an emergency situation.

Table 5.10 Emergency stop via digital operator in remote control mode

Key operation	Description	Digital operator display
Press STOP & REV keys simultaneously	Inverter stops Coasts to stop (base block)	<div style="text-align: center;"> <p>□ Hz</p> <p>XXXX</p> <p>SEQ FRQ FWD</p> <p>□ □ □</p> <p>StP2</p> <p>SEQ FRQ</p> <p>□ □</p> </div>

∖ < indicates flashing display.

Section 6 Test Running

6.1 Precautionary Checks Before Test Running

CAUTION: After mounting and interconnections are completed, please re-check for:

- * Correct connections.

Miswiring of L1 (R), L2 (S), L3 (T) and T1 (U), T2 (V), T3 (W) will destroy the output section of unit.

- * No short circuit conditions exist on output circuit.
- * No loose screw terminals are left behind.
- * Correct input power supply is present at primary of line disconnect.
460VAC line power to N1-200 (or K1-200) series inverter will destroy power section of the unit.

CAUTION:

- * Only start the motor if motor shaft rotation is completely stopped.
- * Even with small loading, never use a motor whose nameplate amperage exceeds the inverter rated current.
- * When starting and stopping the motor, be sure to use the FWD/REV keys or remote control switches.

Never start inverter via magnetic contactor on input power supply side.

Never start the motor with an output contactor.

WARNING: Insure inverter and motor are in safe operating conditions prior to turning on supply voltage.



6.2 Test run

Please follow the instructions below to verify motor rotation direction.

Table 6.1 Verify motor rotation direction

Key operation	Description	Digital operator display
1. Connect to power supply	Inverter enters stopping mode	XXXX
2. Set Fn10=0	Digital operator control mode	
3. Set Fn11=0	Digital operator frequency command	
4. Set Fn25=5 or press up or down keys directly to 5Hz.	Set master frequency = 5Hz Hz lamp lights	<input type="checkbox"/> Hz 5.00
5. Press <input type="button" value="FWD"/>	Verify forward rotation direction Hz & FWD lamps light	<input type="checkbox"/> Hz 5.00 FWD <input type="checkbox"/>
6. Press <input type="button" value="REV"/>	Verify reverse rotation direction Hz & REV lamps light	<input type="checkbox"/> Hz 5.00 REV <input type="checkbox"/>
7. Press <input type="button" value="STOP"/>	Enter idle mode	XXXX

∖ √ indicates flashing display.

Section 7 Setting and Adjustment

7.1 General Description of Settings and Adjustments

Inverter offers many specific adjustments and programming abilities. The adjustments are accessed via digital operator (keypad) or remote control terminals (TM2). Choose the most suitable control mode to suit the application.

Table 7.1 Select control and frequency command mode

Fn10	Fn11	Inverter is controlled by	Operation frequency is set by
0	0	Digital operator	Digital operator (Fn25)
0	1	Digital operator	Remote frequency command
1	0	Remote control terminal (TM2)	Digital operator (Fn25)
1	1	Remote control terminal (TM2)	Remote frequency command

- (1) In digital operator control, **FWD**, **REV**, **JOG** and **STOP** commands are accessed by digital operator.
- (2) In remote control operation, **FWD**, **REV** and **STOP** are accessed by remote control switches (TM2). Please refer to the interconnection diagram fig. 3.1.
- (3) In digital operator frequency command, operation frequency is set by **Fn25**.
- (4) In remote frequency command, operation frequency is set by external analog signal or 10Kohm variable resistor.
- (5) JOG & multi-speed operation (**Fn17-24**, SP1, SP2, SP3) are not limited by **Fn10** & **Fn11**.

Note that the following three functions are effective in remote control only.

- 1: **Fn3**: Remote operation method select
- 2: **Fn14**: Reset
- 3: **Fn16**: Direct start prohibit

7.2 Example of Digital Operation Control and Frequency Command

Please set: **Fn10=0** ----- Digital Operation Control.
Fn11=0 ----- Digital Operation Frequency Command.

Table 7.2 Digital operator control and frequency command

Operation Procedure		Description	Digital Operator Display
1	<input type="checkbox"/> FWD (or <input type="checkbox"/> REV)	* Inverter accelerates from 1Hz to preset frequency of Fn25. * Reverse run is effective when Fn33=0	XX.XX <input type="checkbox"/> Hz 1.00 FWD <input type="checkbox"/> Hz <input type="checkbox"/> 30.00 FWD <input type="checkbox"/>
2	<input type="checkbox"/> ^ arrow key	* Frequency output increases 0.1Hz during 1-180 range by pressing arrow key once. * Frequency will continue to increase if ^ arrow key is pressed. Inverter will accelerate to the frequency command upper limit (Fn6) according to the accel. time set by Fn1. (for instance Fn6=60Hz) * ^ and v arrow keys will be invalid if function parameter is locked (Fn59=1)	<input type="checkbox"/> ^ <input type="checkbox"/> ^ 30.00 FWD <input type="checkbox"/> Hz <input type="checkbox"/> 60.00 FWD <input type="checkbox"/> FWD <input type="checkbox"/>
3	<input type="checkbox"/> v arrow key	* Frequency decreases 0.1 during 1-180Hz range by pressing v key once. * Frequency will continue to decrease if v arrow key is pressed. Inverter will decelerate to the frequency command lower limit (Fn7) or 0 Hz depending on the following conditions:	<input type="checkbox"/> Hz 60.00 FWD <input type="checkbox"/> <input type="checkbox"/> Hz 5.00 FWD <input type="checkbox"/> <input type="checkbox"/> Hz 1.00

Operation Procedure		Description	Digital Operator Display
3		<p>1. Zero speed stop (Fn7=0) Inverter decelerates to 1Hz then stops.</p> <p>2. Run at lower limit (Fn7>0) Inverter decelerates to lower limit and continues to run at preset frequency of Fn7.</p>	<p><input type="checkbox"/> Hz 1.00</p> <p>FWD <input type="checkbox"/></p> <p><input type="checkbox"/> Hz 0.00</p> <p>FWD <input type="checkbox"/></p>
4	<input type="checkbox"/> ^ arrow	<p>* Frequency accelerates. from 1 Hz by pressing <input type="checkbox"/> ^ arrow key once.</p> <p>* Frequency output continues to increase if <input type="checkbox"/> ^ arrow key is pressed.</p>	<p><input type="checkbox"/> Hz 1.00</p> <p>FWD <input type="checkbox"/></p> <p><input type="checkbox"/> Hz 5.00</p> <p>FWD <input type="checkbox"/></p> <p><input type="checkbox"/> Hz 30.00</p> <p>FWD <input type="checkbox"/></p>
5	<input type="checkbox"/> STOP	<p>* Inverter decelerates to 1Hz then stops.</p> <p>* Displays the preset frequency.</p>	<p><input type="checkbox"/> Hz 30.00</p> <p>FWD <input type="checkbox"/></p> <p><input type="checkbox"/> Hz 1.00</p> <p>FWD <input type="checkbox"/></p> <p><input type="checkbox"/> XXXX</p>

indicates flashing display.

Note: * Zero speed stop mode 0.00 is different from stop mode XX.XX

In zero speed stop mode, FWD or REV LED will light, but in stop mode, neither LED's will be lit.

Section 8 Fault Indication

If inverter malfunctions, the fault code will blink on the display and indicate the type of fault that has occurred. Inverter will memorize the last three fault codes automatically in **Fn61**.

Table 8.1 Fault indication

Fault code	Content	Probable cause	What to do	Remark
CPF	Control board failure	1. High electrical noise	1. Install RC type suppressor on all contactor/brake coils.	*
LOC	Function parameter of preset frequency locked	1. Try to amend function parameters or frequency settings by Fn17-25 while function parameter is locked. (Fn60=1 or Fn59=1) 2. Reverse command while reverse run is prohibited. (Fn33=1)	1. Set Fn60=0 2. Set Fn59=0 3. Set Fn33=0	0
StPI	Remote operation error (effective in remote control only. Fn10=1)	1. Problem is due to main power switched on and RUN switched on while direct start is prohibited. (Fn16=1)	1. Set Fn16=0 2. Reset 3. Turn off run switch, and then turn on.	0
StP2	Emergency stop	1. Emergency stop via digital operator in remote control mode by pressing STOP and REV keys.	1. Reset 2. Turn off run switch, and then turn on.	0
ES	Emergency stop	1. Emergency stop via remote operator mode (Fn48=1 or 2)	1. Clear external fault incident. (Terminal 7)	0
bb	baseblock	1. External abnormal signal baseblocks inverter when Fn47=1 or 2.	1. Clear external fault incident. (Terminal 6)	0
EPr	EEPROM error	1. Electronic component problem.	1. Change EEPROM	*
OL-C	Electronic motor thermal overload	1. Overload setting too low. 2. Motor load exceeds inverter rating.	1. Increase code Fn70 to match motor. 2. Increase inverter size.	****

Fault code	Content	Probable cause	What to do	Remark
OC-S	Over current during starting	1. Motor is shorted 2. Inverter output transistor is shorted. 3. Motor is grounded.	1. Clear short circuit 2. Replace inverter 3. Remove the grounded circuit	* **
OC-A	Over current during accel.	1. Accel. time is set too short. 2. Incorrect V/F pattern selection. 3. Motor capacity exceeds inverter rating.	1. Extend accel. time 2. Select the optimum V/F pattern. 3. Select a larger HP inverter.	* ** ***
OC-d	Over current during decel.	1. Decel time is set too short 2. Motor capacity is too large.	1. Extend decel. time 2. Select a larger HP inverter	* ** ***
OC-C	Electronic motor thermal overload	1. Transient load is changed. 2. Motor is overloaded	1. Check motor load 2. Increase inverter size	* ** *** ****
OC	Over current in stop mode	1. Inverter is damaged.	1. Notify your supplier 2. Replace inverter	* **
OU-A	Over voltage during acceleration	1. Input voltage fluctuation. 2. Inverter is in current limit. 3. Inverter is undersized.	1. Check input voltage. 2. Raise current stall level. 3. Increase size of inverter.	* ** ***
OU-C	Over voltage during constant speed	1. Decel. time is set too short. 2. Input voltage fluctuation 3. Insufficient D.B. resistor	1. Extend decel. time. 2. Check input voltage. 3. Install larger D.B. resistor	* ** ***
OU-D	Over voltage in stop mode	1. Input voltage fluctuation 2. Inverter is damaged. 3. Insufficient D.B. resistor. 4. D.B. unit is damaged.	1. Check input voltage 2. Notify your supplier to check. 3. Install larger D.B. resistor. 4. Check and or replace.	* **
LU-C	Low voltage during constant speed.	1. Input voltage is too low. 2. Momentary power failure>15mS	1. Correct input voltage. 2. Inspect bus bar system for collector bounce.	* ** ***
LU	Low voltage in stop mode	1. Same as above.	1. Same as above.	* ** ***
OH-C	Heatsink overheat during constant speed	1. Ambient temperature is too high. 2. Motor overloads.	1. Lower the ambient temperature. 2. Run motor without load. Check load condition.	* ** ***
OH	Heatsink overheat	1. Ambient temperature is too high 2. Inverter load too high.	1. Lower the ambient temperature 2. Decrease load	* ** ***
Serr	Input sequence error	1. Input sequence contacts closure out of order. 2. Pushbutton defective.	1. Check contact sequence 2. Replace pushbutton	0
Fre	Forward and reverse error	1. Both forward and reverse inputs are active. 2. Mis-wiring or short circuit.	1. Check contact sequence. 2. Replace or repair wiring.	0
TrL	Travel limit closure	1. Active only if Fn46 or Fn47 is set to 4 or 5. 2. Travel limit input is closed.	1. Reprogram drive if function is not desired. 2. Back machine off travel limit.	0
ELF	Elapsed time sentinel	1. Active only if Fn59 is programmed with time. 2. Maintenance reminder.	1. Program Fn59 to 0 to defeat function. 2. Reset inverter.	* ** ***

Fault code	Content	Probable cause	What to do	Remark
Err 1	Operation error	1. Try to change frequency by pressing \wedge or \vee keys when Fn11=1. 2. Try to change CPU version by pressing \wedge or \vee 3. Try to change those functions with *** in Remark column by pressing \wedge or \vee in "run" mode.	1. Fn11=0. 2. CPU version (Fn64) can't be changed. 3. Change those functions in function list with *** in Remark column in "stop" mode.	0
Err 2	Setting error	1. Fn6 (frequency upper limit) is set under Fn7 (frequency lower limit)	1. Set Fn6 (upper limit) to be greater than Fn7 (lower limit).	0
Err 3	Setting error	1. Fn5=15, V/F curve is set too steep.	1. Fn38-Fn40 ≤ 65 Fn37-Fn39 2. Fn40-Fn42 ≤ 65 Fn39-Fn41	0
Err 4	Setting error	1. Incorrectly set frequency of Fn37-Fn42.	1. Set as follows: Fn37>Fn39>Fn41 Fn38>=Fn40>=Fn42	0
Err 5	Communication error	N/A	Please refer to communication operation manual.	0

0 No fault trip occurs only display of fault code.







* Registered in Fn61

** Fault relay operate

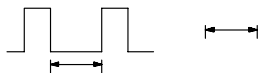
*** Auto reset

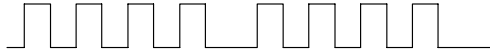
**** Applicable only to models VFK1 2110-2220, VFK1 4110-4220

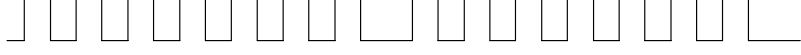
Table 8.2 Alarm LED signal

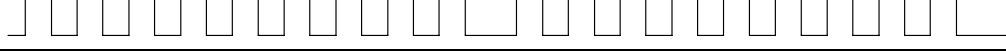
Fault code		Alarm LED signal
1	OH	
2	OC	
3	OV	
4	LV	
5	OC-S	
6	bb	
7	ES	
8	EP _r	
9	CPF	

- * **OH** : Means all modes of overheat.
- * **OC** : Means all modes of over current.
- * **OV** : Means all modes of over voltage.
- * **LV** : Means all modes of low voltage.

* In "stop" mode, alarm LED extinguishes, in "run" mode and "zero speed stop" mode, alarm LED lights.

Section 9 Maintenance



Inverter requires almost no routine checks. It will function efficiently and its normal operation lifetime will be longer if it is kept clean, cool and dry.

Especially check for tightness of electrical connections, discoloration or other signs of overheating. During service inspection, turn off AC main circuit power and wait for charging indicator LED 101 to extinguish (or at least 10 minutes) before touching any circuit components. Failure to adhere to this warning could result in serious or lethal injuries.

- (1) Clean up internal dust and dirt
- (2) Check for tightness of electrical connection.
- (3) Perform meggar test
 - (a) Remove all connection wires from the complete unit when doing meggar test.
 - (b) Meggar test can be applied on main circuit. Note! Never do meggar test on control circuit. The insulation resistance of DC500V tester should be more than 5M ohm.

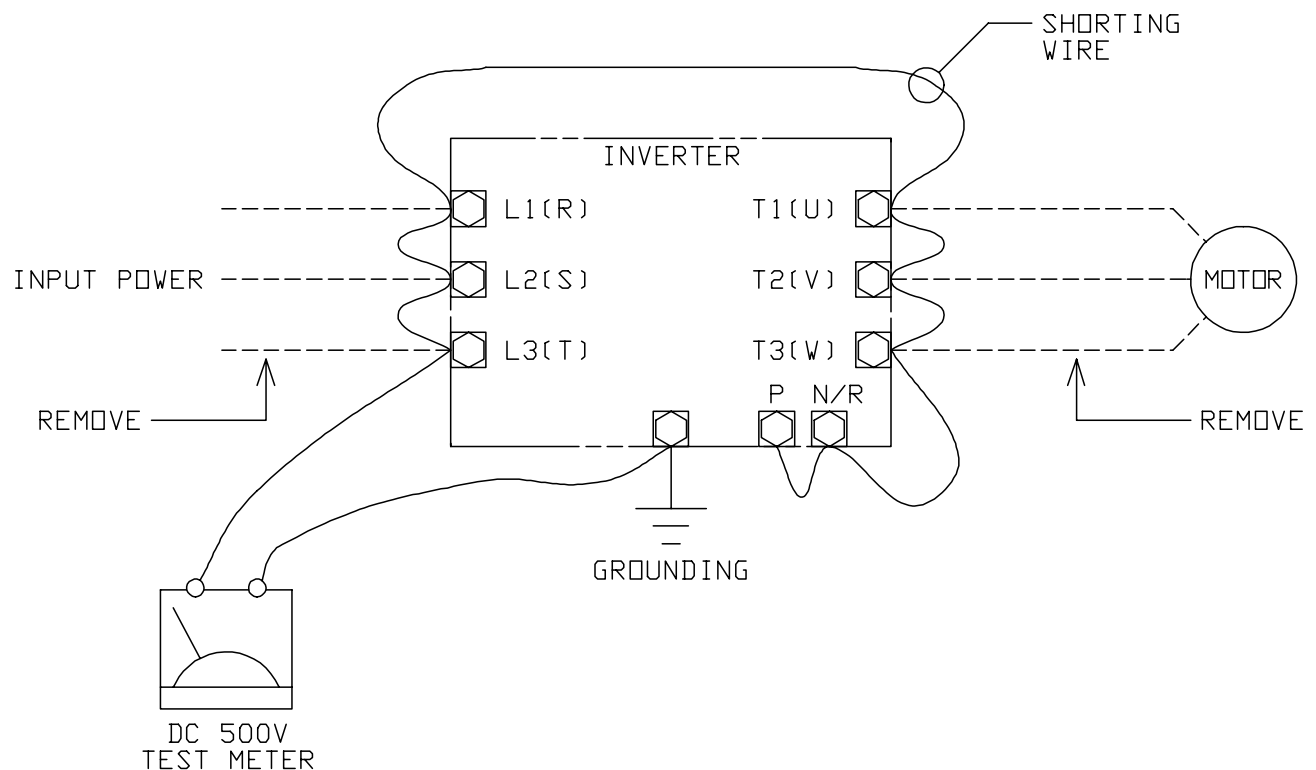





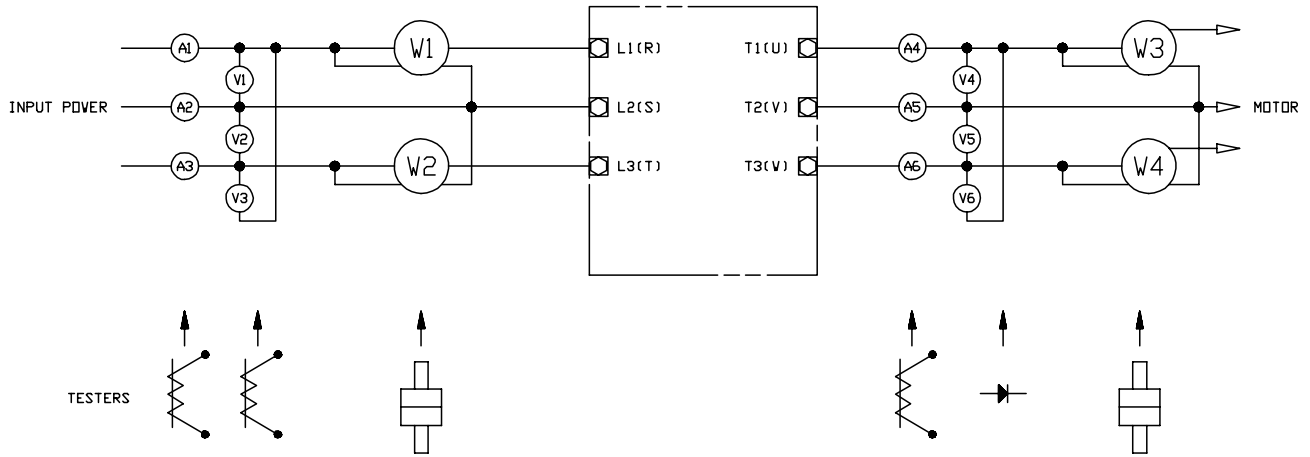

Note: Never conduct a meggar test on control circuit! Damage will result to inverter.

Reference

a. Measurement of Voltage and Current

The result for measuring primary and secondary voltage and current will be somewhat different because of the variety of measuring instruments and harmonics generated by inverter. Refer to the following illustration for measurement.



MEASUREMENT	TESTING POINTS	TESTER	REMARKS
Input voltage V_i	(V1) (V2) (V3)	 Moving iron type	
Input current I_i	(A1) (A2) (A3)	 Moving iron type	
Input power P_i	(W1) (W2)	 Electrodynamometer	$P_i = W_1 + W_2$
Input power factor PF_i	$PF_i = \frac{P_i}{\sqrt{3} V_o \cdot I_o} \times 100\%$		
Output voltage V_o	(V4) (V5) (V6)	 Rectifier type	+ - 3% of maximum output voltage
Output current I_o	(A4) (A5) (A6)	 Moving iron type	Current should be under inverter rated current
Output power P_o	(W3) (W4)	 Electrodynamometer	$P_o = W_3 + W_4$
Output power factor PF_o	$PF_o = \frac{P_o}{\sqrt{3} V_o \cdot I_o} \times 100\%$		

b. Troubleshooting Procedure

(1) Motor doesn't run

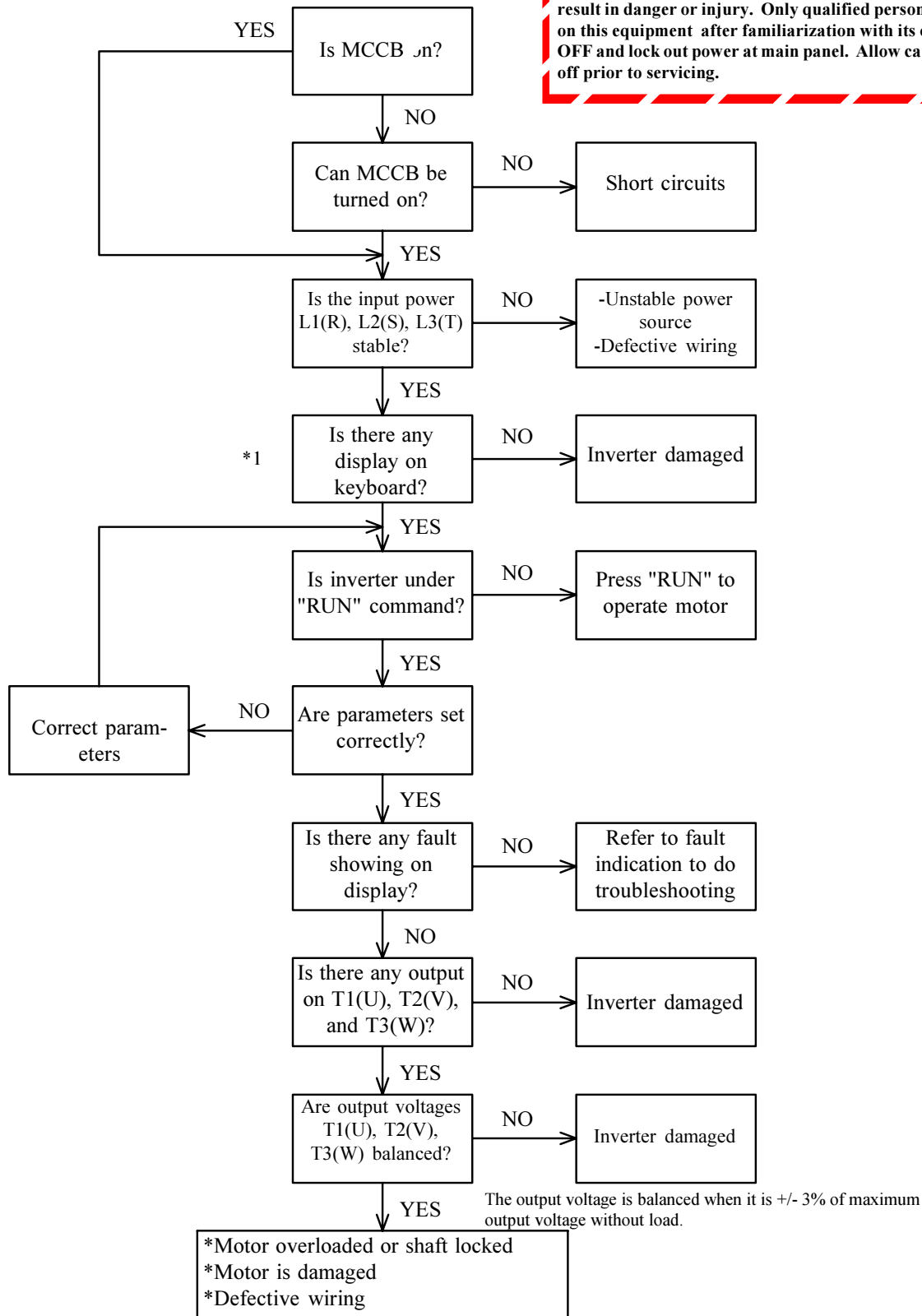
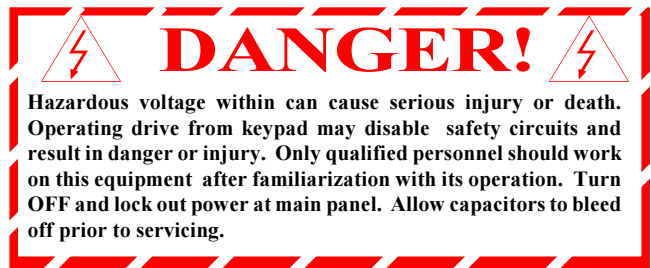

*1 Without keypad, check if LED 101 is on.

(2) Motor overheated

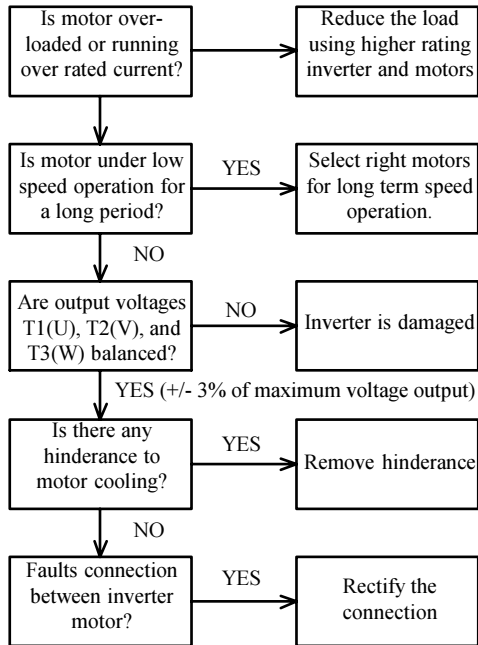

(3) Motor does not run smoothly

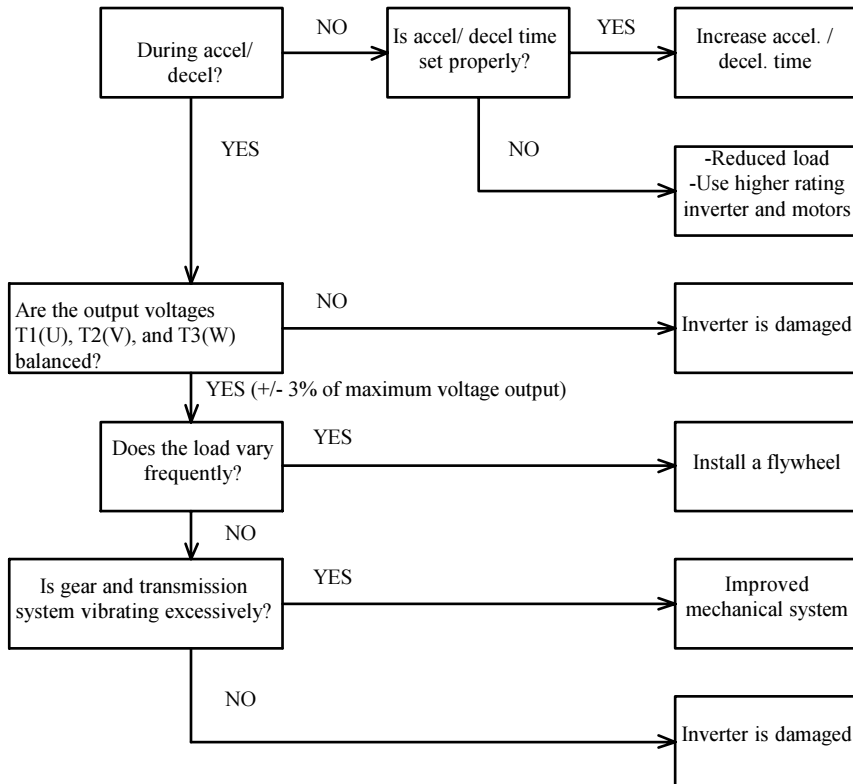

c. Electromagnetic Compatibility (EMC)

Similar to all modern PWM variable speed drives, inverters use fast switching of high voltage and currents to achieve high efficiency and reduced motor acoustic noise. This results in electromagnetic interference (EMI) and radio frequency interference (RFI) that occurs at the switching frequency and harmonics of this frequency.

For operational reasons the interference may need to be suppressed. As EMI and RFI can involve very complex coupling modes, not all solutions can be easily found.

EC Directives

Inverters are able to comply with the EC Directives 89/336/EEC on limits to EMI and RFI with the use of optional filters. Independent testing has demonstrated compliance to the following standards when the optional filters are used.

EN 55011:	1991, Class A
pr EN 50082-2:	1992 (in part)
IEC 801-2:	1984
IEC 801-3:	1984
IEC 801-4:	1988

Filtering Selection for N1 Series

All N1 series inverters use the same filter: N1F-2202. Physical dimensions, internal circuit layout and component values are detailed below.

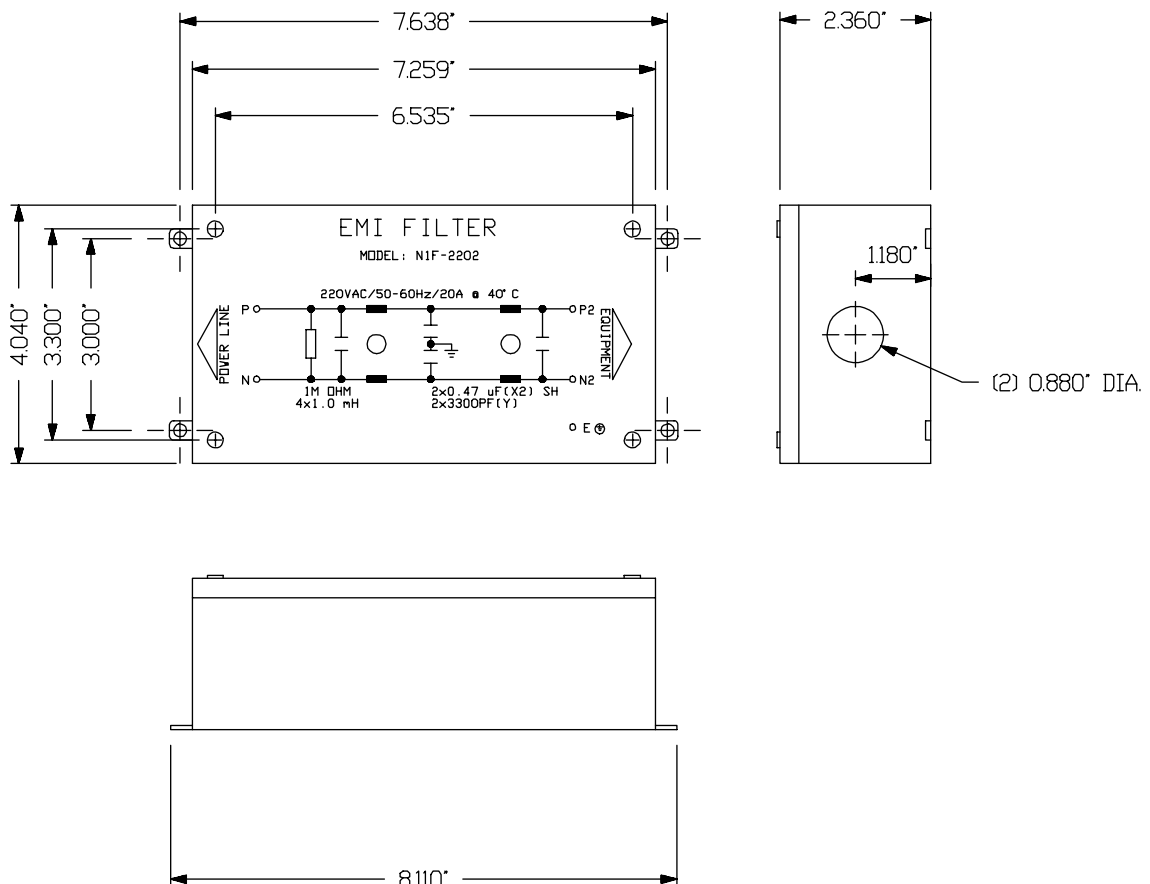

K1 Series

Select a filter for the K1 series inverters from the following table. Physical dimensions, internal circuit layout and component areas are also detailed below.

	K1F-4103	K1F-4203	K1F-4603
C1, C2, C3	0.47uF/500VAC	1.0uF/500VAC	3.3uF/500VAC
C4, C5, C6	0.47uF/500VAC	1.0uF/500VAC	2.2uF/500VAC
C7, C8, C9	0.0233uF/400VAC	0.0233uF/400VAC	0.07uF/400VAC
L1, L2	2.0mH	2.3mH	0.8mH
R	RDN 1.5MJ/1W/500VAC		
INV, TYPE	K1-401/2/3	K1-405/8/10	K1-415/20/30

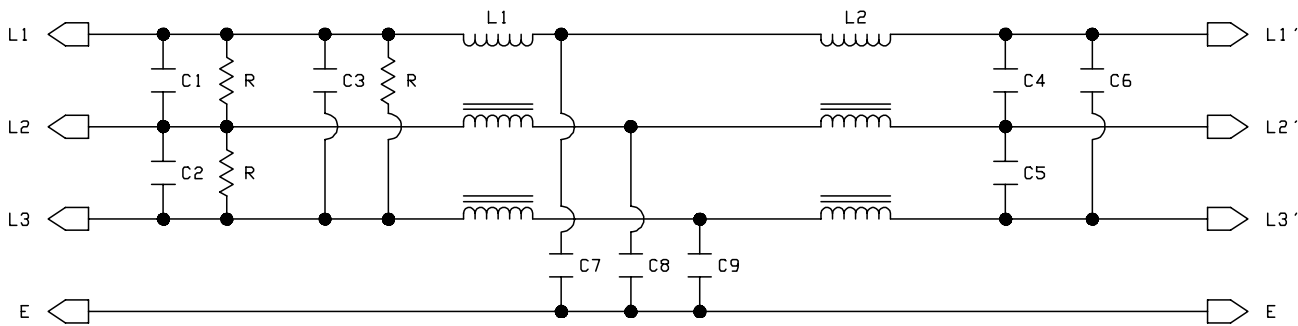

K1F-4103/ K1F-4203 Dimensions

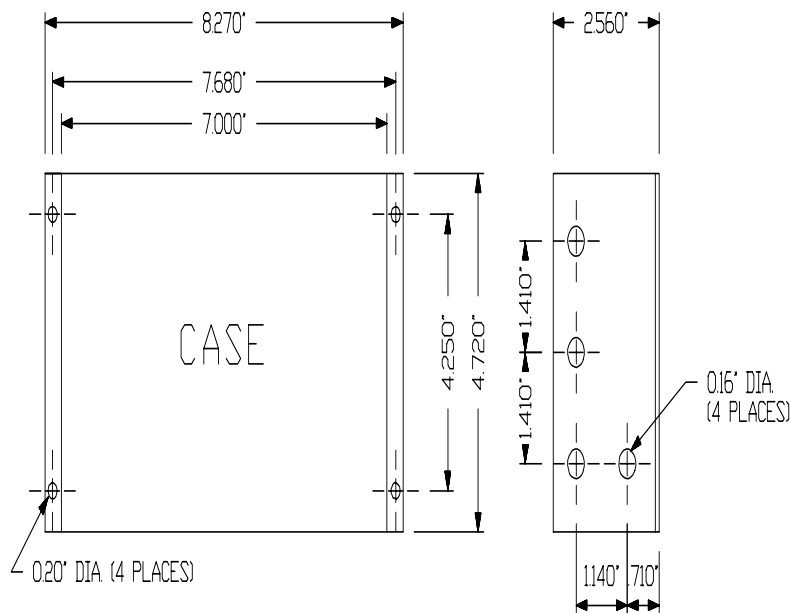

K1F-4603 Dimensions

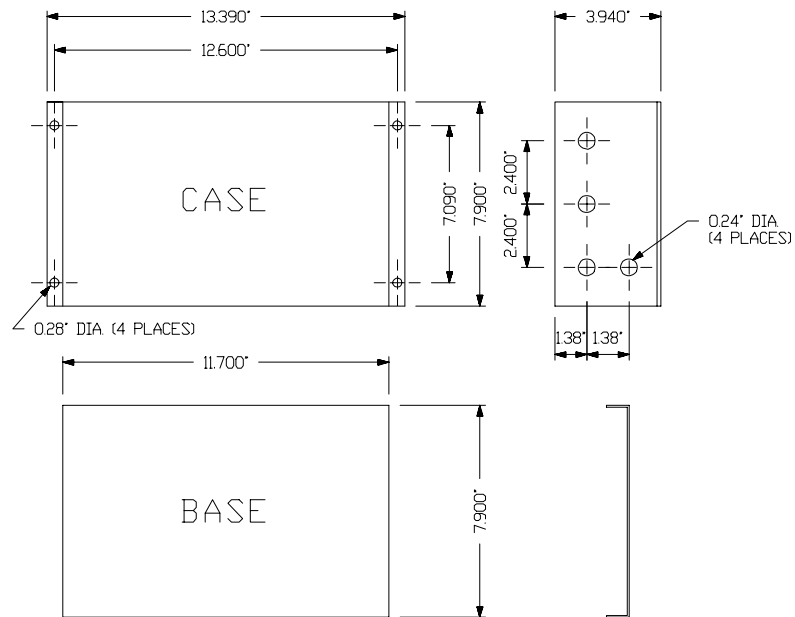

Installation and Interconnection

The filter must be mounted and earth grounded to the same panel and as close as possible to the inverter. If the connection exceeds 30cm, a flat cable should be used for the earth connection between the filter and the inverter.

Interconnection diagrams for the N1 and K1 series inverters are detailed below.

N1 series Interconnection

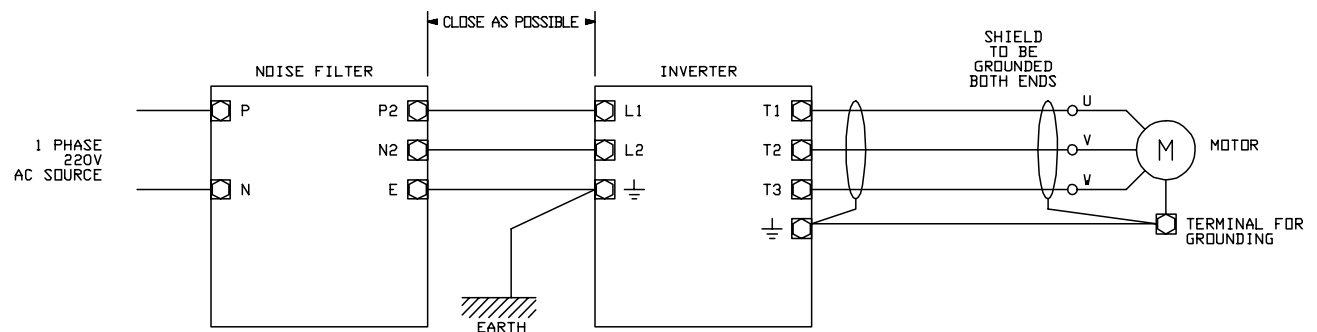

COMPLETELY GROUND THE SHIELD MADE OF METAL SCREEN, ENCLOSED PANEL, ETC WITH AS SHORT A WIRE AS POSSIBLE.

K1 Series Interconnection

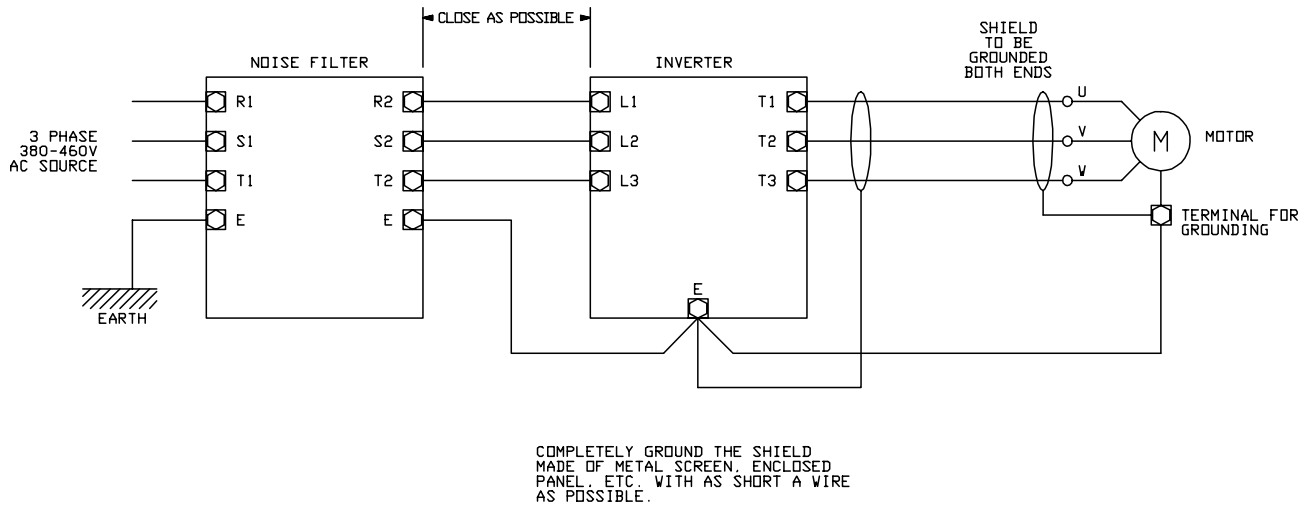

Additional precautions to limit EMI and RFI

The use of the recommended filters and installation as detailed will reduce EMI and RFI to the limits specified by the EC directives. However, additional precautions and equipment may be necessary to provide practical solutions to any interference caused by variable speed drives. These are detailed below:

1. It is usually necessary to screen the cable between the inverter and motor. The screen must be earth ground directly to the inverter earth and the motor earth. Use a clamp style earth connection around entire shield.
2. The length of the cable between the inverter and motor must be kept as short as possible to limit cable capacitance. If cable length exceeds 50m, an output inductor may be required.
3. The connections in the screening system must provide a low impedance at high frequencies. To achieve this additional clamping, removal of paint or use of special connectors may be required.
4. Control and signal cables must be shielded and separated from power cables. A distance of 30cm is usually adequate. Where control or signal cables cross power cables, this must be done at 90 degrees.
5. The use of ferrite core inductors on the input or output and capacitor filters on the input may provide some additional filtering for specific applications where interference exist. Consult Drivecon Corporation for more details.

Appendix A Peripheral

Ground Fault Protection when motor is running.

If a "ground fault" occurs while motor is running, transient surge currents will destroy the power section of inverter. Inverter offers an optional ZCT protection unit to detect the surge current and disable the output section whenever ground fault occurs.



Installation:

1. Disconnect inverter from power source
 2. Make sure that the charge lamp (LED 101) extinguishes or wait at least 10 minutes before taking next step.
 3. Disconnect and thread output line (T1, T2 & T3) through ZCT and connect ZCT to CON4. (as shown on diagram)
- * Be sure to thread all T1, T2, & T3 through ZCT.
 - * Max. cross section of T1, T2, & T3 should be ≤ 10 AWG.
- (Please refer to the specification of 3.2.2)
4. Reconnect output lines (T1, T2, T3) back in proper sequence.

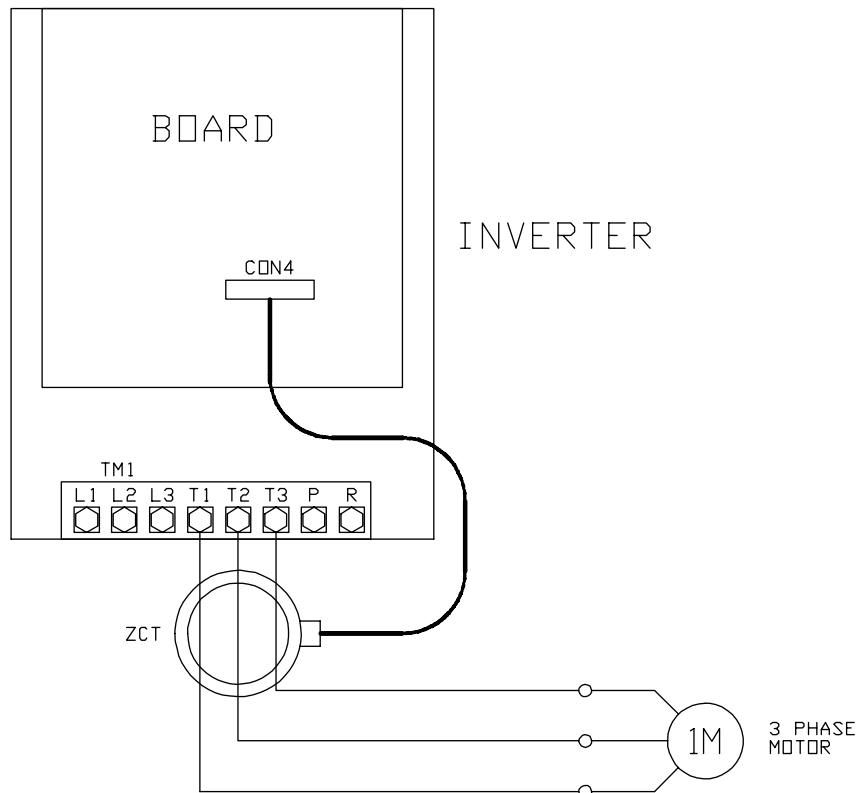

Note: ZCT is standard on all VFK1 2110-2220 and VFK1 4110-4220.

Appendix B Peripheral

KDOP-02 Digital Operator Interface Extension Cable

(A) Accessories

Please check the following accessories after unpacking:

1. Screw x 2 (M4)
2. Shielding cover
3. Extension cable (including rubber bushing and connectors)
KW3001: 1 meter
KW3002: 2 meters
KW3003: 3 meters

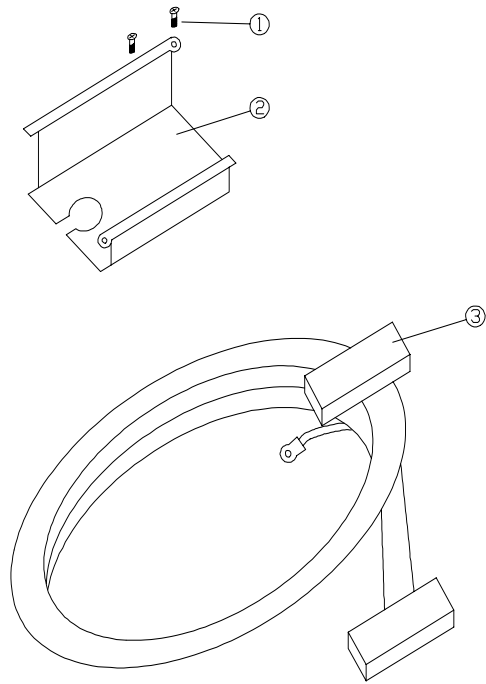

(B) Installation procedure

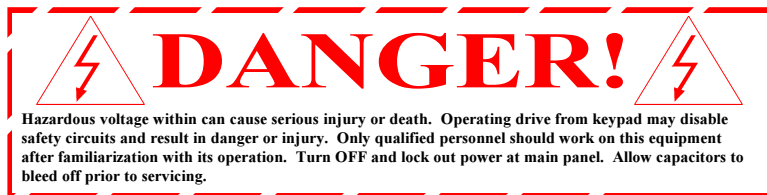

1. Disconnect inverter from power source. Make sure that LED display goes off before proceeding to the next step.
2. Remove the front panel.
Make sure the charge lamp (LED 101) extinguishes or wait at least 10 minutes before touching any circuit or components.
3. Disconnect KDOP-02 digital operator from CON 6.
4. Remove KDOP-02 from inverter.
5. Connect cable with grounding terminal to CON 6 and fix the grounding terminal on inverter as shown in the diagram.
6. Clinch the rubber bushing to the hole on shielding cover.
7. Fix the shielding cover on the position of KDOP-02.
8. Adjust the cable and install the front panel.
9. Connect the other terminal of cable KDOP-02.

Important!

To prevent electric noise, be sure to ground inverter as per users manual section 3.3.

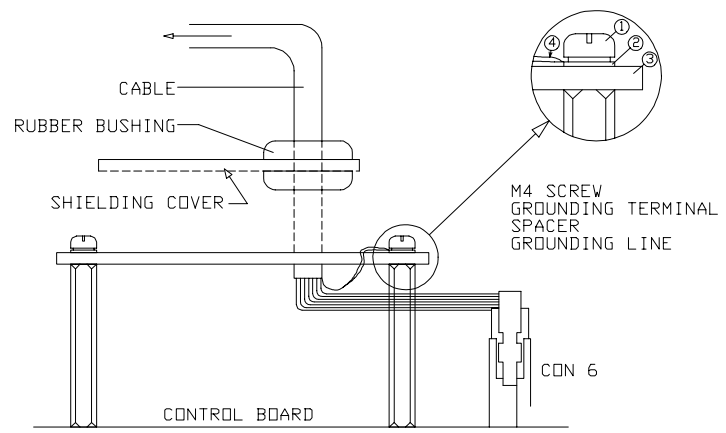



D61530 120VAC 'DIRECT COMMAND' INPUT ISOLATOR **(D61531 24VAC 'DIRECT COMMAND' INPUT ISOLATOR)**

For use with VFK1

FUNCTION

The D61530 120VAC (D61531 24VAC) input isolator is designed to mount directly on the control terminal strip (TM2) of VFK1 model inverters. The function of the D61530 (D61531) is to allow direct connection to 120VAC (24VAC) control inputs while providing filtering and isolation to the VFK1. Each of 6 input lines are optically isolated from the corresponding logic level output. A S.P.D.T. relay is provided for output of either running mode, at constant speed, or up to speed. A convenient pull apart terminal strip (TB1) is provided for 120VAC (24VAC) input signal connections.

MOUNTING

Refer to diagram D61530-1 for description of mounting procedures. The D61530 (D61531) mounts directly to the lower tier of the VFK1's control terminal strip (TM2). The terminal strip connections provide support for the printed circuit board and 6 connection points: COM, SP2, REV, SYN+, +VE, -VE. The other 5 connections are made by way of flying wire leads: FWD, SP1, SP3, RST, SYN-.

MOUNTING INSTRUCTIONS

DANGER! Hazardous voltage within can cause serious injury or death. Operating drive from keypad may disable safety circuits and result in danger or injury. Only qualified personnel should work on this equipment after familiarization with its operation. Turn OFF and lock out power at main panel. Allow capacitors to bleed off prior to servicing.

Insure all power sources are removed from VFK1 and that D.C. bus is discharged prior to handling VFK1 inverter.

- 1) Remove cover of VFK1 inverter to expose main printed circuit board terminal strip (TM2).
- 2) Connect all wires to lower power terminal strip (TM1) first since this terminal strip will not be accessible once the D61530 (D61531) is installed. Keep wire length as short as possible to prevent interference with D61530 (D61531). Follow the VFK1 connection diagram for wiring connection.
- 3) Remove screws COM, SP2, REV, SYN+, +VE, -VE on lower tier of terminal strip.
- 4) Place D61530 (D61531) on to terminal strip (TM2) making sure to check that corresponding terminals are aligned correctly. Replace 6 screws and tighten each starting from center and working outwards. There will be a screw on each side of TM2 **not** connected to the D61530 (D61531) isolator. Tighten to 10 in-lbs.

5) Connect each of five colored wires to the corresponding terminal on upper tier of TM2.

<u>Terminal</u>	<u>Color</u>
FWD	Orange
SP1	Violet
SP3	Blue
RST	Yellow
SYN-	Brown

6) Wire 120VAC input signals to detachable section of D61530 (D61531) terminal strip (TB1). Wire gauge is size 24AWG to 14AWG maximum. Only a single wire is permitted in each terminal for wires larger than 18AWG.

7) Replace cover.

8) Should TB1 need to be removed from its mating socket, DO NOT pull on TB1 or the wires attached to TB1. Damage to socket and connector may result. Pry apart where both halves meet with a small flat blade screwdriver.

CONNECTION

CAUTION: This solid state isolator will be damaged if the output (connection to drive terminals) are wired in parallel with any external circuits.

Two directions, multi-function 1, 2 & 3 and reset can be controlled directly from 120VAC (24VAC) control signals. The following chart defines the input to output relationship.

D61530 Input (D61531)		<u>Output Function</u>
<u>Terminal TB1</u>		
F	(1)	FORWARD command
R	(2)	REVERSE command
2	(3)	Multi-function 1
3	(4)	Multi-function 2
4	(5)	Multi-function 3
5	(6)	Reset
ACN	(7)	120VAC (24VAC) neutral
RLA	(8)	Output relay N.O.
RLC	(9)	Output relay common
RLB	(10)	Output relay N.C.

The input terminal block (TB1) will accept 24AWG-14AWG wire maximum.

SPECIFICATIONS

Input voltage	120VAC (24VAC) \pm 10% max. variance
Input frequency	50/60Hz \pm 2%
Input current	5mA max. per input
Relay type	S.P.D.T. form C
Relay rating	120V AC 1 amp maximum 100V DC .2 amp maximum
Response time	On 15mS Off 40mS
Relay response time	On 10mS Off 10mS
Operating temperature	-20 to 50 deg. C

Should any problem exist or assistance is required contact:



820 Lakeside Drive - Gurnee, IL 60031

Ph: 847-855-9150 Fax: 847-855-9650

800-374-8266

E-mail: sales@drivecon.com

www.drivecon.com

D61530 / D61531 'DIRECT COMMAND' ISOLATOR MOUNTING DIAGRAM.

NOTE: VFK1-207 SHOWN. OTHER MODELS MAY DIFFER IN APPEARANCE.
SHOWN WITH COVER REMOVED.

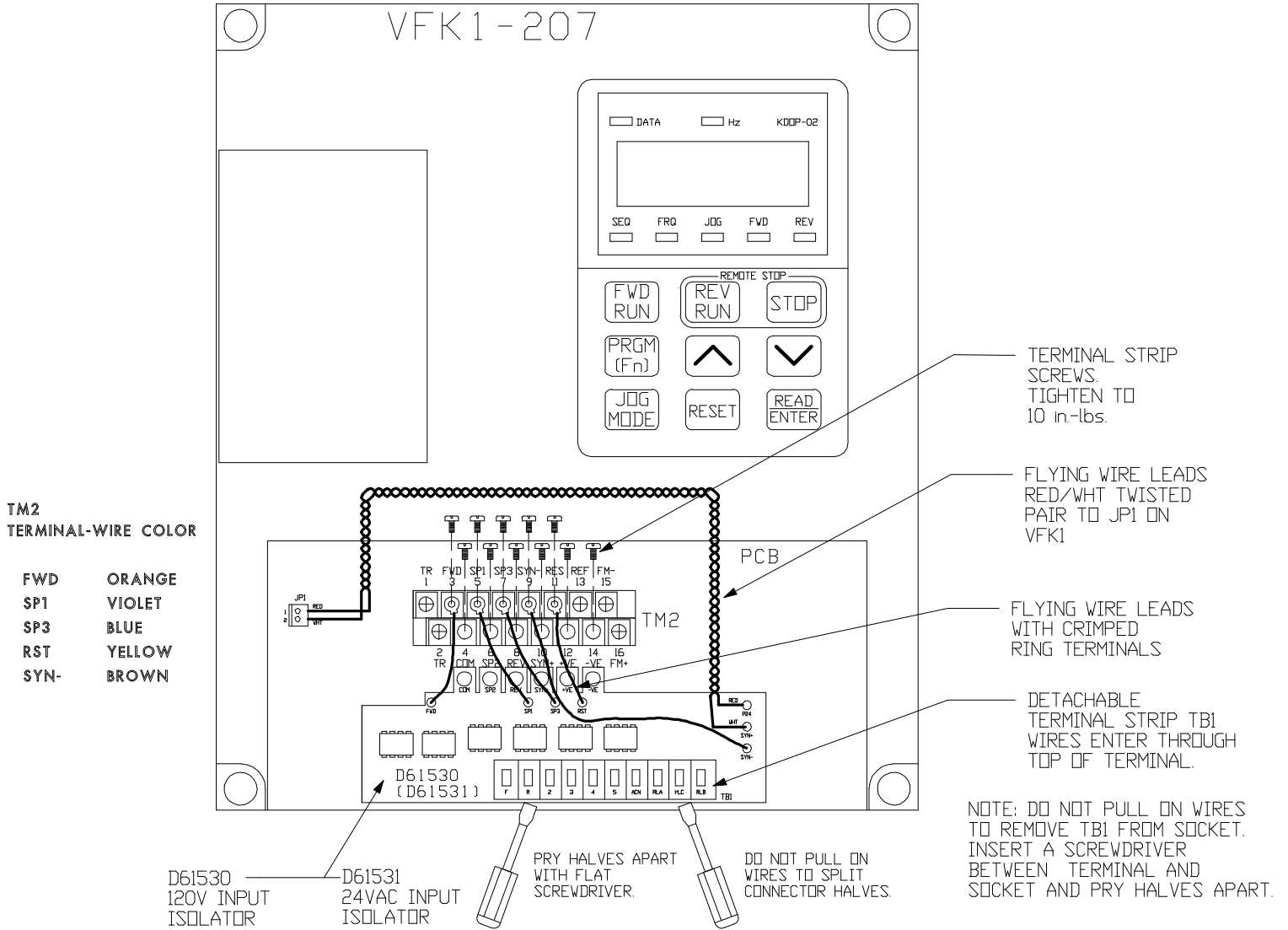

- 1.) REMOVE COVER OF VFK1 INVERTER TO EXPOSE MAIN PCB.
- 2.) CONNECT POWER WIRES TO TM1 OF VFK1.
- 3.) UNSCREW COM, SP2, REV, SYN+, +VE, -VE TERMINALS ON LOWER TIER OF TERMINAL TM2.
- 4.) PLACE D61530 (D61531) IN CORRESPONDING TERMINALS, REPLACE SCREWS AND TIGHTEN.
- 5.) CONNECT WIRES TO UPPER TIER OF TERMINAL TM2.
- 6.) CONNECT 120V INPUT WIRES TO TB1 OF D61530.
- 7.) REPLACE COVER.
- 8.) DO NOT PULL ON WIRES TO REMOVE TB1. PRY AS SHOWN WITH A FLAT SCREWDRIVER.

D61530 120VAC D61531 24VAC INPUT TERMINAL (TB1)	FUNCTION	VFK1 FUNCTION CODES
F (1)	120V (24V) IN- FWD	Fn03
R (2)	120V (24V) IN- REV	Fn03
2 (3)	120V (24V) MULTIFUNCTION #1	Fn46
3 (4)	120V (24V) MULTIFUNCTION #2	Fn47
4 (5)	120V (24V) MULTIFUNCTION #3	Fn48
5 (6)	120V (24V) RESET	-
ACN (7)	120V (24V) NEUTRAL INPUT	
RLA (8)	120V (24V) RELAY N.O.	Fn08
RLC (9)	RELAY COMMON	Fn08
RLB (10)	RELAY N.C.	Fn08

TITLE: D61530 120VAC ISOLATOR MOUNTING D61531 24VAC ISOLATOR MOUNTING		DRAWING VERSION		REVISION NO.	REVISION DATE
CLIENT:		FINAL			
LOCATION:		DATE: 10-22-98			
DESIGNER: GLC	PROJECT: D61530-1	START-UP DATE: / /	SHEET # 001 OF 001		

D61530 / D61531

'DIRECT COMMAND'

P.C.B. CONNECTIONS

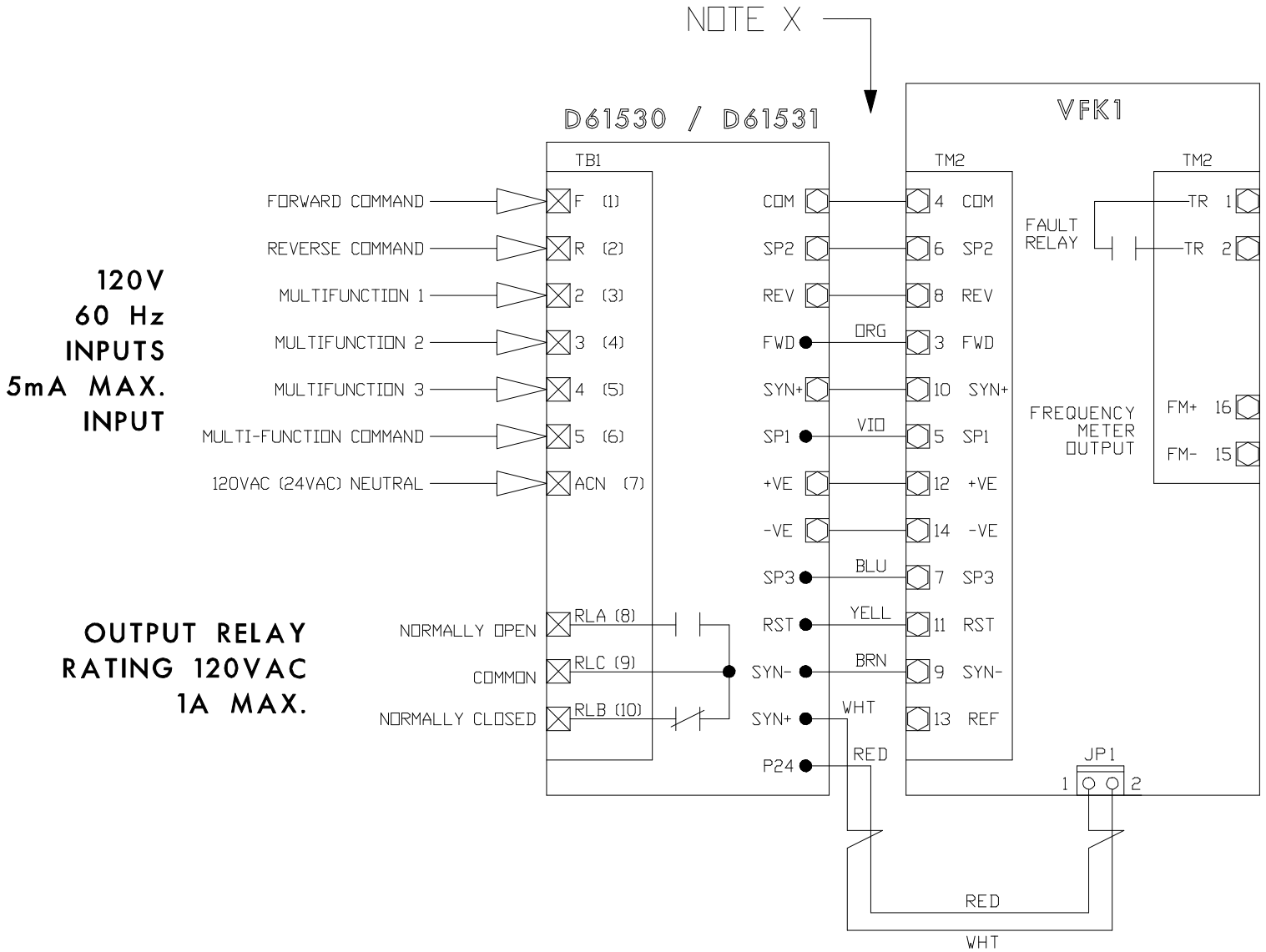

NOTE X: DO NOT MAKE ANY EXTERNAL CONNECTIONS
IN PARALLEL WITH ISOLATOR PCB'S OUTPUT.

TITLE:		DRAWING VERSION		REVISION NO.	REVISION DATE
D61530 'DIRECT COMMAND' 120V INPUT ISOLATOR D61531 'DIRECT COMMAND' 24V INPUT ISOLATOR		FINAL			
CLIENT:		DATE: 10-22-98			
LOCATION:		START-UP DATE: / /			
DESIGNER: RMP	PROJECT: D61530-2			SHEET # 001	OF 001

VFK/VFN Drive Settings



Drivecon Corporation

820 Lakeside Drive - Gurnee, IL 60031
 PH: (847) 855-9150 FAX: (847) 855-9650
 1-800-DRIVCON (374-8266)

MODEL: _____ SERIAL NUMBER: _____

CODE	DESCRIPTION	RANGE	SET UNIT	DEFAULT	VALUE AT SHIPMENT	INSTALLATION REVISION	COMMENTS	REMARK
Fn00	Communication ID No.	0-32	-	1				
Fn01	Accel Time 1	0.1-800.0 sec.	0.1 sec.	5 sec. (10)				***
Fn02	Decel Time 1	0.1-800.0 sec.	0.1 sec.	5 sec. (10)				***
Fn03	Remote Operation Select	0: FWD/STOP, REV/STOP 1: FWD/REV RUN/STOP	-	0				
Fn04	50/60 Hz ID no.		-	1				**
Fn05	V/F Pattern Select	0-15	-	1				
Fn06	Freq. Output Upper Limit	1-180Hz	0.1 Hz	60 Hz				
Fn07	Freq. Output Lower Limit	0-180Hz	0.1 Hz	0 Hz				
Fn08	Multi- Function Output	0: Run Mode 1: Constant Speed 2: Set frequency	-	0				
Fn09	Set Frequency	1-180Hz	0.1 Hz	5 Hz				
Fn10	Control Mode Select	0: Digital operator Frequency command 1: Remote control	-	0				*
Fn11	Freq. Command Method Select	0: Digital operator command 1: Remote frequency command.	-	0				*
Fn12	Stall prevention level	0 or 110%-200%	1%	170%				**
Fn13	Fault Relay Logic	0: Normally open N/O 1: Normally close N/C	-	0				
Fn14	Reset	0: Disable 1: Enable	-	0				
Fn15	Stall Prevention	1: Disable 2-8: Extend 2-8 times	-	1 (N/A)				***
Fn16	Direct Start Inhibit	0: Disable 1: Enable	-	0				
Fn17	Multi-Speed 1	0-180Hz	0.1 Hz	5 Hz				***
Fn18	Multi-Speed 2	0-180Hz	0.1 Hz	10 Hz				***
Fn19	Multi-Speed 3	0-180Hz	0.1 Hz	20 Hz				***
Fn20	Multi-Speed 4	0-180Hz	0.1 Hz	30 Hz				***
Fn21	Multi-Speed 5	0-180Hz	0.1 Hz	40 Hz				***
Fn22	Multi-Speed 6	0-180Hz	0.1 Hz	50 Hz				***
Fn23	Multi-Speed 7	0-180Hz	0.1 Hz	60 Hz				***
Fn24	Jog Freq. Reference	0-180Hz	0.1 Hz	2 Hz				***
Fn25	Master Freq. Reference	0-180Hz	0.1 Hz	5 Hz				***
Fn26	BIAS of Freq. Reference	0-180Hz	0.1 Hz	0 Hz				***
Fn27	Positive/Negative BIAS	0: Positive 1: Negative	-	0				***
Fn28	Max. Speed set by full freq. ref.	1-180 Hz	0.1 Hz	60 Hz				***
Fn29	Remote frequency command response	0: Direct Proportional Signal 1: Inverse Proportional Signal	-	0				
Fn30	Remote freq. command select	0: 1-5V, 4-20mA command, 10 Kohm Potentiometer 1: 0-10V	-	0				
Fn31	Con. Speed Stall Prevn. Enable Freq.	1-180Hz	0.1 Hz	60 Hz				(N/A)
Fn31	Con. Speed Stall Prevn. Enable level	0-160%	1	160%				**
Fn32	Con. Speed Stall Prevn. Decel. Time	0.1-800 sec.	0.1 sec.	0.8 sec. (3)				***
Fn33	Reverse run prohibit	0: Disable 1: Enable	-	0				
Fn34	Auto restart interval	0-800 sec.	0.1 sec.	5 sec.				
Fn35	Auto restart times	0-10	-	0				
Fn36	Scan times [Filter time]	0-9999	-	1001			Control inputs and external frequency reference	***
Fn37	Max. freq.	50-180Hz	0.1 Hz	60 Hz				
Fn38	Max. voltage ratio	0-100%	0.1%	100%				
Fn39	Mid. frequency	1-180Hz	0.1 Hz	3 Hz				
Fn40	Mid. voltage ratio	0-100%	0.1%	7.5% (4.2)				
Fn41	Min. frequency	1-180Hz	0.1 Hz	1.0 Hz				
Fn42	Min. voltage ratio	0-100%	0	7.5%				
Fn43	Carrier frequency select	1440-3600 Hz	1 Hz	2880 Hz				

- * The factory setting of N1 is 1
- ** This function is only available on VFK1 2110-2220, 4110-4220 models
- *** The setting can be changed in "Run" mode
- () Setting of VFK1 2110-2220 and VFK1 4110-4220 only.

VFK/VFN Drive Settings



Drivecon Corporation

820 Lakeside Drive - Gurnee, IL 60031
 PH: (847) 855-9150 FAX: (847) 855-9650
 1-800-DRIVCON (374-8266)

MODEL: _____

SERIAL NUMBER: _____

CODE	DESCRIPTION	RANGE	SET UNIT	DEFAULT	VALUE AT SHIPMENT	INSTALLATION REVISION	COMMENTS	REMARK
Fn44	Full Scale Meter Output	1-180Hz	0.1 Hz	60 Hz				***
Fn45	Meter Output Calibration	-250	1	5				***
Fn46	Multi-input 1	0: SP1 1: Accel/Decel time 2 enable 2: Hold at present speed	-	0				
Fn47	Multi-input 2	0: SP2 1: Coast to Stop N/O 2: Coast to Stop N/C	-	0				
Fn48	Multi-input 3	0: SP3 1: Decl. to Stop N/O 2: Decl. to Stop N/C	-	0				
Fn49	Accel time 2	0.1-800 sec.	0.1 sec.	10 sec.				***
Fn50	Decel time 2	0.1-800 sec.	0.1 sec.	10 sec.				***
Fn51	Display mode select	0: Hz 1-4: RPM for motor 5-8: Line speed / decimal point select	-	0				***
		9: Motor amps						**
Fn52	Linear Speed Display	0-9999	-	1800			Active when Fn51=5-8	***
Fn53	DC Braking time	0.1-25.5 sec.	0.1 sec.	0.5 sec.				
Fn54	DC Braking injection frequency	0-10 Hz 0: Free run to stop	0.1 Hz	2 Hz				
Fn55	DC Braking level	0-20%	0.1%	8% (6)				
Fn56	Baud rate of communication	0: 2400 bps 1: 4800 bps 2: 9600 bps 3: 19200 bps	-	2				
Fn57	Communication command response mode	0-15	-	1				
Fn58	Communication transmit object	0-33	-	0				***
Fn59	Frequency lock select	0: Disable 1: Enable [Fn17-25 not adjustable]	-	0				***
Fn60	Parameter lock select	0: Disable 1: Enable	-	0			Fn0-16 and Fn26-58 are read only	***
Fn61	Fault sequence reference	1: XXX, 2: XXX, 3: XXX	-					
Fn64	CPU version [Eprom version]		-					
Fn65	Prohibited Frequency (1)	0-180 Hz	0.1 Hz	0 Hz				**
Fn66	Prohibited Frequency (2)	0-180 Hz	0.1 Hz	0 Hz				**
Fn67	Prohibited Frequency (3)	0-180 Hz	0.1 Hz	0 Hz				**
Fn68	Prohibited Frequency Range	0-5 Hz	0.1 Hz					**
Fn69	Motor Type [Electronic thermal characteristics]	0: Standard Motor [TEFC] 1: Inverter Motor [TEBC]	-	0			K1-2110-222 K1-4110-422	**
Fn70	Motor Rated Current % of FLA		0.1A				K1-2110-222 K1-4110-422	**
Fn71	Inverter Capacity Select	K1-2110-M3 K1-2150-M3 K1-2220-M3 K1-4110-M3 K1-4150-M3 K1-4220-M3	-				K1-2110-222 K1-4110-422 ONLY	**
JP2	Jumper 2		-					

Make a record of all settings and post next to drive for future reference.

* The factory setting of N1 is 1

** This function is only available on VFK1 2110-2220, 4110-4220 models

*** The setting can be changed in "Run" mode

() Setting of VFK1 2110-2220 and VFK1 4110-4220 only.

Terminal Function List

	Terminal number	Terminal name	Function and Description
TM1	L1/L2/L3 (R,S,T)	Input terminal	N1-200: 1 phase/3 phase, 200-230VAC +/- 10% K1-200: 3phase, 200-230VAC +/- 10% 50/60 Hz +/- 5% K1-400: 3 phase, 380-460VAC +/- 10% 50/60 Hz +/- 5%
	T1/T2/T3 (U/V/W)	Output terminal	N1-200: 3 phase, 200-230VAC K1-200: 3 phase, 200-230VAC K1-400: 3 phase, 380-460VAC
	P/R	External braking resistor terminal	For external braking resistor
	E	Ground terminal	Earth Ground
TM2	1/2	Fault relay	1a fault relay (250VAC/1A, 30VDC/1A)
	3	Forward	Forward command
	4	Common	Control signal common terminal
	5/6/7	Multi-speed	7 step multi-speed operation
	8	Reverse	Reverse command
	9	Common terminal	Common only for terminal 10
	10	Programmable Output signal	Output at "run", "synchronous" mode or when inverter reaches any preset frequency.
	11	Reset input	Reset inverter operation.
	12	Frequency command potentiometer positive	Positive terminal of 10K ohm frequency command potentiometer.
	13	Frequency command potentiometer wiper	Wiper of 10K ohm frequency command potentiometer.
	14	Frequency command potentiometer negative	Negative terminal of 10K ohm frequency command potentiometer.
15/16	Frequency meter output	Drive of remote analog frequency meter. 0-10VDC	
	Jumper 1	Frequency signal switch	Select remote frequency control signal
	Jumper 2		



820 Lakeside Drive - Gurnee, IL 60031
800-374-8266

PH: 847-855-9150 FAX: 847-855-9650
www.drivecon.com E-mail: drive.sales@drivecon.com