

Boston Gear®

Ratiotrol®

AC Motor Speed Control

Installation and Operation

Doc. No. 07640

BCX Series
1/6-5 HP



Boston
Gear

SECTION	PAGE
General Description2
Dimensions2
Mounting Specifications2
Safety Warnings2-3
Locations3
Power Wiring4
Controller Setup4

SECTION	PAGE
Local Speed Potentiometer5
Control Wiring5-6
Ratings6-7
Functional Specifications7
Diagnostics7
Troubleshooting8
Options8-9

GENERAL DESCRIPTION

The BCX is general purpose, low cost, AC micro-controller which provides adjustable speed control of conventional AC motors in applications exhibiting a variety of load characteristics. The controller converts the fixed frequency and voltage of the AC line power source to a sine coded pulse width modulated adjustable voltage and frequency output. The power section utilizes insulated Gate Bipolar Transistors (IGBT's) operating at a fixed carrier frequency providing high starting torque and cool motor operation.

The features of the BCX and its available options allow the application of this controller to numerous industrial applications.

DIMENSIONS

Figure 1. 1/6 - 1 HP, 115/230 VAC

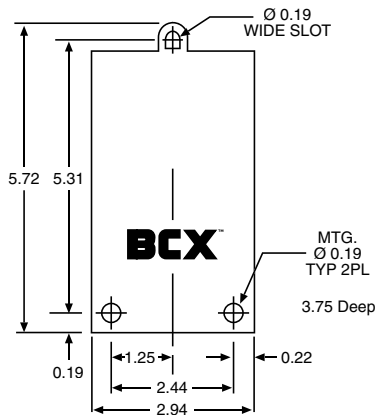

DIMENSIONS

Figure 2. 1 1/2 - 5 HP 230 VAC and 1 - 5 HP 460 VAC

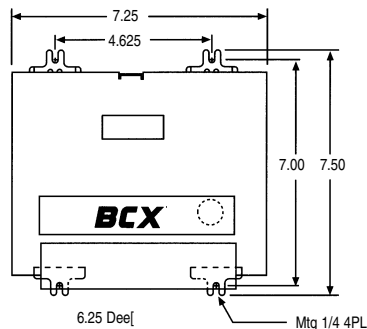

MOUNTING SPECIFICATIONS

Table 1.

SAFETY WARNINGS

Location	Indoor (Protected from Corrosive Gas and Dust)	
Ambient Temperature	32 to 104 degrees F (0 to 40 degrees C)	
Humidity	0-95% (noncondensing)	
Altitude	3300 feet (1000 meters) above sea level	
Size	1/6-1Hp, 230 VAC	5.72"H x 2.94"W x 3.75"D
	1 1/2-5, 230 VAC & 1-5HP, 460 VAC	7.50"H x 7.25"W x 6.25"D
Weight	1/6-1HP, 230 VAC	1.5 lbs.
	1 1/2-5 230 VAC & 1-5, 460 VAC	5.6 lbs.
Enclosure	NEMA 1, NEMA 4 optional	
Clearance	4" around the heat sink	
Orientation	Heat sink fins vertical	

1. You, as the owner or operator of this controller, have the responsibility to have the users of this equipment trained in its operation and warned of any potential hazards which can cause personal injury or loss of life.
2. The printed wiring board and its components are at AC line potential and can result in personal injury or loss of life if mishandled.
3. Wait at least 5 minutes before accessing the unit after AC power has been disconnected from the controller. Failure to do this could cause electric shock which can result in personal injury or loss of life.
4. Follow all local electrical and safety codes including the National Electrical Code (NEC), and when applicable, the Occupational Safety and Health Act (OSHA). This controller should be installed, adapted and serviced by qualified electrical maintenance personnel familiar with the installation and operation of the equipment and the hazards involved.
5. Do not mount the controller on a wall or surface that is combustible. A steel or metal surface is recommended.
6. Be sure the power source conforms to the requirements of the equipment.
7. Do not wire the AC power leads to the controller motor output terminals. This will damage the controller.

8. All wiring should be rated for at least 600 volts. For 1/6-1HP, 230 VAC controllers only, leads should be tinned, or UL recognized ferrules similar to Altech Type H2.5/7 Catalog Number 2223.0 should be used. Also for 1/6-1 HP controllers, solid wire, maximum size 14AWG, 600 volts, may be used. For 1 HP, 460 VAC and 1-1/2-5 HP, 230/460 VAC controllers, use stranded wire. Maximum wire size and terminal tightening torque for all BCX controller power wiring are shown in Table 2.

Table 2.

Controller Rating	Maximum Wire Size (AWG)	Terminal Tightening Torque (IN-LBS)
1/6-1HP, 230 VAC	14	3.5
1-1/2-5HP, 230 VAC	14	a
1-5HP, 460 VAC	14	12

- a. Spring clamp wire terminals are used instead of screw terminal.
9. The motor and controller must be securely and adequately grounded. Connect the green or bare (ground) wire of the line supply to the controller ground connection terminal. For 1/6-1HP, 230 VAC controllers, a green ground connection terminal is located beside the power terminals. For 1 HP, 460 VAC and 1-1/2-5HP, 230/460 VAC controllers, two ground connection terminals are located on the conduit entry bracket. For 1/6-1HP, 230 VAC controllers, use a lug similar to AMP Part Number 35432 or 324955. For 1HP, 460 VAC and 1-1/2-5HP, 230/460 VAC controllers, use a lug similar to AMP Part Number 34162 for 16-14 AWG wire size or AMP Part Number 322455 for 12-10 AWG wire size.
10. AC power, motor and control wiring should be run separately from each other.
11. The controller should not be connected to a line supply capable of supplying more than 10,000 rms symmetrical amperes.
12. If the AC line impedance is low (i.e.,m the KVA rating of the AC supply is greater than three times the KVA rating of the controller), the optional input line chokes should be used.
13. Do not operate the controller in an explosive atmosphere or near high capacitive discharge electrical equipment (e.g. electrical welders).
14. Use insulated, non-metallic tools when making adjustments. Be careful not to touch any components except the adjusting trim pots.
15. Keep the controller dry and free of dust, dirt and debris.
16. If an application requires a contactor between the controller output and the motor, the contactor should be prevented from picking up when the controller is turned-

on. If this is not practical, the controller output current rating must be greater than the stalled torque (current) rating of the motor. If multiple motors must connect to a single controller that is turned-on, the controller output current output current rating must be greater than the total stalled torque (current) rating of all the motors.

LOCATIONS

Figure 3. 1/6-1HP, 115/230 VAC

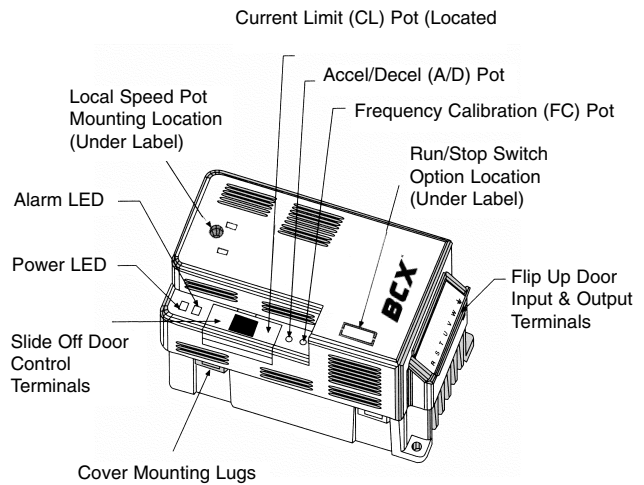
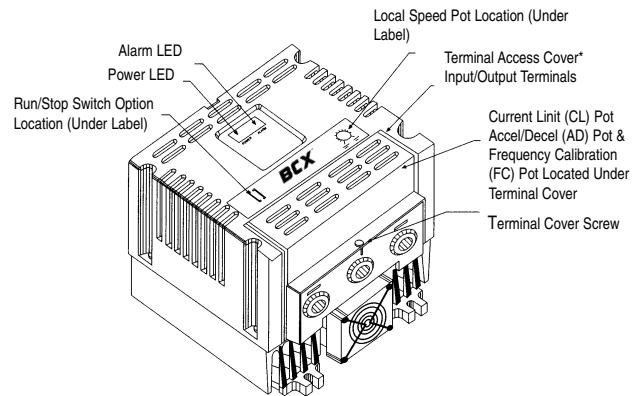

Figure 4. 1 1/2-5HP, 230 VAC and 1-5HP, 460 VAC



*To Remove Cover, Remove Cover Screw. Push on Ventilation Holes, And Pull Downward.

POWER WIRING

Figure 5. Terminal Description

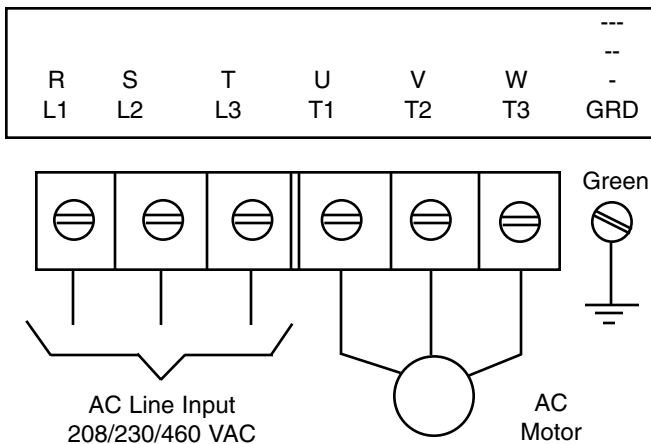

For 1/6 - 1HP, 230 VAC controllers, terminals are located under the flip-up door (see Figure 3 on page 3). Terminal legends are located on the door.

For 1 1/2-5 HP, 230 VAC & 1-5 HP, 460 VAC controllers, terminals are located beneath the terminal access cover (see Figure 4 on page 3). Terminal legends are located on the printed wiring board. Two ground connection terminals are provided on the conduit entry bracket.

For 208/230 VAC single phase operation, connect the AC line input to any two input terminals (R[L1], S[L2], or T[3]).

Review safety warnings on pages 2 and 3.

If the motor rotation is in the incorrect direction with a forward command, interchange any two motor leads at the controller.

CONTROLLER SETUP

This controller contains three potentiometers used to calibrate the controller to your particular application. For the location of these potentiometers see Figure 3 on page 3 or Figure 4 on page 3, as applicable.

Figure 6. Current Limit Potentiometer
CURRENT LIMIT (CL):



Limits motor output current to prevent motor overload.

Adjustment range: 75 to 150 percent of rated current. This potentiometer adjusts both the current limit and the overload current for the BCX. The following table lists the recommended setting of the current limit potentiometer for various horsepower ratings.

This setting provides and overload protection rating of

approximately 125%. The potentiometer may be adjusted to provided a lower or higher overload rating if desired.

Table 3.

Input Voltage	Hp Rating	Current Limit Potentiometer Setting	Nominal Full Load Current (amps)	Current Limit Setting (amps)	Motor Overload Setting (amps)
208/230 VAC	1/6	Fully Clockwise (L)	1.00	1.50	1.25
	1/4	Mid Position (M)*	1.49	2.23	1.86
	1/3	Fully Clockwise (H)	1.99	2.98	2.49
	1/2	Fully Counterclockwise (L)	2.00	3.00	2.50
	3/4	Mid Position (M)*	2.98	4.47	3.72
	1	Fully Clockwise (H)	3.98	5.97	4.97
	1 1/2	Fully Clockwise (H)	5.70	8.55	7.13
	2	Fully Clockwise (H)	7.50	11.25	9.38
	3	Fully Clockwise (H)	10.60	15.90	13.25
	5	Fully Clockwise (H)	16.70	25.05	20.88
460 VAC	1	Fully Clockwise (H)	1.80	2.70	2.25
	1 1/2	Fully Clockwise (H)	2.60	3.90	3.25
	2	Fully Clockwise (H)	3.40	5.10	4.25
	3	Fully Clockwise (H)	4.80	7.20	6.00
	5	Fully Clockwise (H)	7.60	11.40	9.50

* Mid Position (M) provides an overload rating of approximately 140%. Adjust the potentiometer as shown in Figure 6 to provide 125% rating.

ACCELERATION/DECELERATION TIME (A/D):

A common linear adjustment potentiometer is provided for acceleration and deceleration time adjustment. Adjustment range: 0.1 to 100 seconds. 9factory preset for 10 seconds).

FREQUENCY CALIBRATION (FC):

Adjustment Range: 50 to 120 Hz (factory preset for 60 Hz). This potentiometer adjusts the maximum frequency of the BCX controller. For settings above 60 Hz, torque will decrease.

Figure 7. Volts Per Hertz Pattern

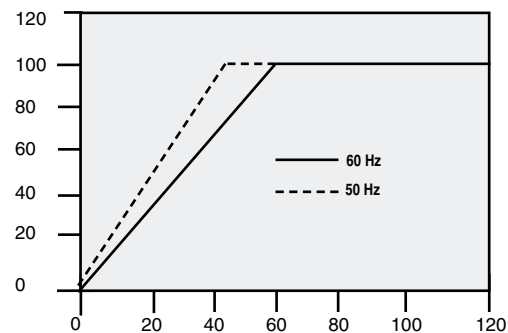

Do not change the setting from 60 Hertz unless required. 60 Hertz setting is not defined or easily reset. It is suggested that you mark the 60 Hertz location to return to this setting if necessary.

See Figure 3 (page 3) or Figure 4 (page 3), as applicable, for potentiometer location.

LOCAL SPEED POTENTIOMETER INSTALLATION

For 1/6 - 1 HP, 230 VAC Controller

A local speed potentiometer is provided loose to be installed in the controller's cover if required.

1. Remove the cover by gently lifting the four mounting lugs while pulling on cover.
2. Cut a hole in the label to accept speed potentiometer. For location see Figure 3 on page 3.
3. The speed potentiometer presses into the back of the cover as shown in Figure 8. Care should be taken to ensure that the wires on the pot are positioned correctly.

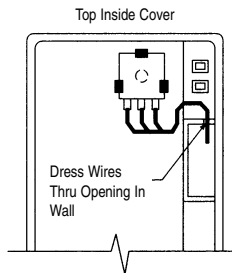

Figure 8.

4. Replace cover.
5. Wire the speed pot to Terminals 4, 5, and 6 as shown in Figure 9.

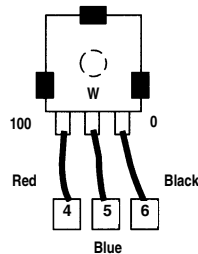

Figure 9.

LOCAL SPEED POTENTIOMETER INSTALLATION

1 1/2 - 5 HP, 230 VAC and 1-5 HP, 460 VAC Controllers

1. Remove the terminal access door from the controller.
2. Remove the controller cover by unscrewing the four cover screws and lifting off the cover.
3. Cut around the perimeter of the potentiometer mounting hole in the label on the front of the controller cover. For location, see Figure 10.
4. Remove the nut and washer from the potentiometer shaft.

5. Insert the potentiometer shaft through the mounting hole from the rear of the cover. Be sure to position the wires toward the terminal access door in the cover.
6. Secure the potentiometer by placing its washer and nut onto its shaft, and then tightening the nut.
7. Pull the potentiometer wires through the terminal access door.
8. Place the controller cover onto the controller and tighten the four cover screws.
9. Connect the potentiometer wires to Terminals 4, 5, and 6, as shown in Figure 9.
10. Attach the terminal access door.

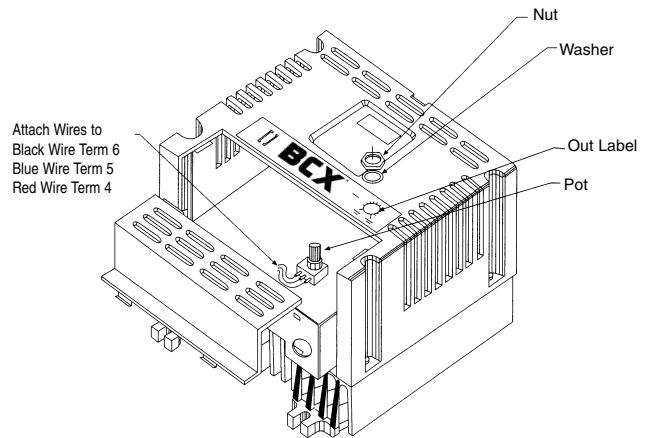

Figure 10.

CONTROL WIRING

Control wiring should utilize multiconductor twisted cable and be kept as short as possible. If more than 10 feet of wiring is required, relays with bifurcated contacts should be mounted near the controller to interface remote logic to the controller. These terminals are not isolated from the AC line and cannot be grounded or connected to other drives. Any relay or potentiometer used with this drive must have a minimum dielectric rating of 2000 volts from any terminal to grounded metal parts.

For the location of the control wiring terminals, see Figure 3 or Figure 4, as applicable. The layout and position of the control wiring terminals and location of Jumper J1 will vary depending on the BCX model. The terminal numbers and J1 designation are located on the printed wiring board.

TERMINAL DESCRIPTIONS

1	2	3	4	5	6
Non Isolated Common	Digital Input #1	Digital Input #2	+5VDC	Analog Input (0-5VDC)	Non Isolated Common

Figure 11.

RUN FORWARD AND STOP BY MOMENTARY (three wire control) PUSHBUTTONS (jumper must be removed or stored on right pin only of connector). See Figure 12. If motor rotation is incorrect, interchange two motor leads at the controller.

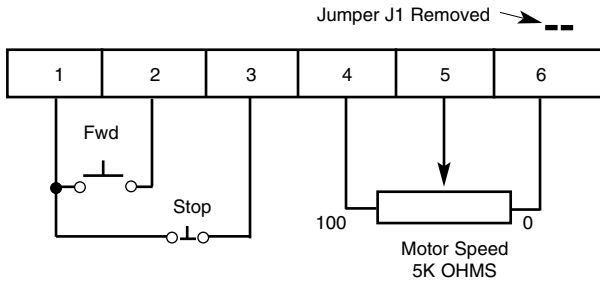
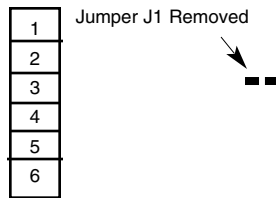

Figure 12.

Note: In smaller sizes (1/6 - 1 HP, 230 VAC) this terminal strip is located vertically.



FORWARD AND REVERSE BY MAINTAINED (two wire control) CONTACTS (jumper installed on both pins.) See Figure 13.

If motor rotation is incorrect, interchange two motor leads at the controller.

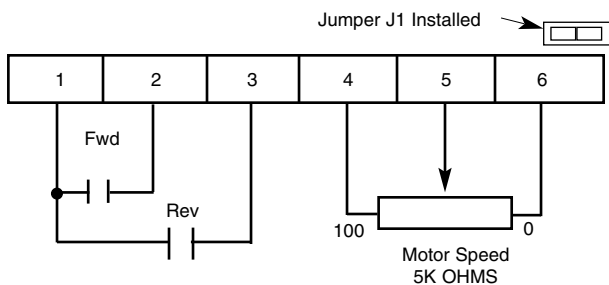

Figure 13.

LINE STARTING (starting and stopping the controller with AC line power) (jumper installed on both pins). See Figure 14.

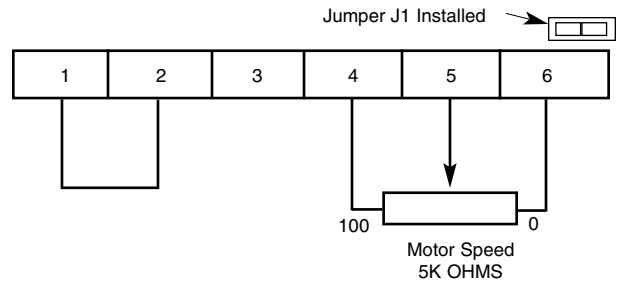

Figure 14.

Controllers rated 1-1/2 - 5 HP, 230V and 1-5 HP, 460V use screwless control terminals. To secure or release a wire, insert a screwdriver into the appropriate slot as shown in Figure 15. Then turn the screwdriver slightly to open the terminal window.

* Control Terminals 7 and 8 are only on controllers rated 1-1/2 - 5 HP, 230V and 1 - 5 HP, 460V. These terminals connect to an internal N.O. Drive OK relay contract which closes when the controller is powered up and opens if the controller faults. The contact, rated 0.5A at 125 VAC and 2.0A at 30VDC, can be used for an external fault indicator.

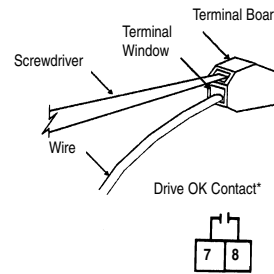

Figure 15.

RATINGS

Table 4. Ratings - Three Phase 208/230 VAC Input

Motor		Controller						Catalog Number
HP	KW	208VAC			230 VAC			
		KVA	Input Amps	Output Amps	KVA	Input Amps	Output Amps	
1/6	0.12	0.50	1.4	0.94	0.56	1.4	0.85	BCX2003
1/4	0.19	0.58	1.6	1.5	0.64	1.6	1.4	
1/3	0.25	0.79	2.2	2.0	0.88	2.2	1.8	
1/2	0.37	1.01	2.8	2.2	1.12	2.8	2.0	BCX2010
3/4	0.56	1.44	4.0	3.1	1.59	4.0	2.8	
1	0.75	1.73	4.8	3.9	1.83	4.6	3.6	
1-1/2	1.12	2.77	7.7	5.7	2.79	7.0	5.2	BCX2015
2	1.50	3.39	9.4	7.5	3.39	8.5	6.8	BCX2020
3	2.24	5.12	14.2	10.6	5.10	12.8	9.6	BCX2030
5	3.73	8.50	23.6	16.7	8.49	21.3	15.2	BCX2050

RATINGS

Table 5. Ratings - Three Phase 460 VAC Input

Motor		Controller			
HP	KW	460 VAC			Catalog Number
		KVA	Input Amps	Output Amps	
1	0.75	1.91	2.4	1.8	BCX4010
1-1/2	1.12	2.79	3.5	2.6	BCX4015
2	1.50	3.43	4.3	3.4	BCX4020
3	2.24	5.10	6.4	4.8	BCX4030
5	3.73	8.53	10.7	7.6	BCX4050

Table 6. Ratings - Single Phase 115/208/230 VAC Input

Motor		Controller							Catalog Number	
HP	KW	115 VAC			208 VAC			230 VAC		
		KVA	Input Amps	Output Amps	Input Amps*	Output Amps	Input Amps	Output Amps		
1/6	0.12	BCX2003	0.42	2.0	0.94	0.44	1.9	0.85	BCX2003	
1/4	0.19	and	0.52	2.5	1.5	0.55	2.4	1.4		
1/3	0.25	2XV-03	0.71	3.4	2.0	0.76	3.3	1.8		
1/2	0.37	BCX2010	0.99	4.8	2.2	1.10	4.8	2.0	BCX2010	
3/4	0.56	and	1.54	7.4	3.1	1.54	6.7	2.8	BCX2015	
1	0.75	2XV-10	2.00	9.6	3.9	2.00	8.7	3.6	BCX2020	
1-1/2	1.12	----	2.91	14.0	5.7	2.92	12.7	5.2	BCX2030	
2	1.50	----	3.58	17.2	7.5	3.57	15.5	6.8	BCX2050	

*3-phase output

FUNCTIONAL SPECIFICATIONS

Table 7.

Function/Feature	Specification	
Control Characteristics	Line Voltage Variation	+/-10% of Rated
	Output Voltage	0-208/230/460 VAC, 3 Phase
	Carrier Frequency	2.3 KHz Fixed
	Output Frequency Range	0 to 60 HZ (Constant Torque) 60 to 120 HZ (Constant Horsepower)
	Frequency Resolution	0.2% of Maximum Frequency
	Analog Reference	0-5VDC (Not Isolated)
	Accel./Decel. Time	0.1 to 100 Seconds (Common Pot)
	Braking Torque	Approximately 20%
	V/F Pattern	Linear to 60 Hz (50 Hz)
	Efficiency (At Rated Speed, Rated Frequency)	Controller 95%
Protection	Overload	150% for 1 Minute
	Overvoltage	DC Bus Exceeds 400VDC @ 230 VAC Line 775VDC @ 460 VAC Line
	Undervoltage	DC Bus Below 161VDC @ 230 VAC Line 322 VDC @ 460 VAC Line
	Momentary Power Loss	0.1 Second Minimum
Operation	Digital Input Signals	2 Provided, Programmable (Jumper) Forward, Reverse, Stop
	Control Voltage	Supplied +5 VDC (Non-Isolated Line Start Mode)
	Built-in Features	Power Light Alarm Light
	Location	Indoor (Protected From Corrosive Gas and dust)
Environmental Conditions	Ambient Temperature	32 to 104 Degrees F (0 to 40 Degrees C)
	Humidity	0-95% (Non-Condensing)
	Altitude	3300 Feet (1000M) Maximum Above Sea Level
Enclosure	NEMA 1	
Codes	UL, cUL Listed	

BCX Products use high speed PWM (Pulse Width Modulation) for efficient motor control at all output frequencies. PWM techniques expose the motor to higher spike voltages than it would experience when operated from commercial power at fixed speed. In some cases, spike voltages can cause the motor's insulation system to break down. The motor's ability to tolerate these voltage peaks is a function of the motor's design, including the type of magnet wire, method of winding and other insulation material characteristics. This phenomenon may be a concern on 460 VAC motors, and is typically less of a concern at 230 VAC or below. The voltage spikes tend to be larger for longer lengths of cable between the drive and motor. These steps will help minimize and eliminate motor insulation problems:

- On new installations, specify PWM inverter duty rated motors (available from Boston Gear). These motors have superior insulation systems which will tolerate modest voltage spikes.
- For retrofit applications where motor lead lengths are under 150 feet, use optional motor filters connected between the drive and motor.
- For old or new installations with motor lead lengths exceeding 150 feet, consult the factory.

DIAGNOSTICS

The BCX has two LED's for diagnostic purposes (see Figure 3 or Figure 4 for locations).

Power On LED: This yellow LED is illuminated when more than 50 VDC is present on the DC Bus Capacitors. Typically, when power is removed from the BCX, this LED will remain illuminated for up to 5 seconds while the DC bus capacitor voltage discharges. If the motor was not running when power was removed, the LED may remain illuminate for up to 5 minutes.

Alarm LED: When this red LED is illuminated constantly, it indicates that the motor is overloaded and the drive is about to fault due to a motor overload. When the Alarm LED is flashing, it indicates that the drive is faulted. By counting the number of times the Alarm LED flashes, the cause of the fault can be determined. Table 8 Lists the possible fault conditions for the BCX and the number of times the Alarm LED will flash;

Table 8.

Fault Condition	Number of Alarm LED Flashes
Bus Overcurrent Fault	1
Bus Overvoltage Fault	2
Motor Overload Fault	3
Low Bus Voltage Bus	4
PWM Generator Fault	5
Logic Fault	6

Table 9.

# of Flashes	Description	Possible Cause	Solution
1	Bus Overcurrent Fault	Phase to phase short	Check motor leads and wiring in motor or motor leads
		Drive is trying to accelerate the load too quickly	Increase Accel/Decel pot setting by turning clockwise
2	Bus Overvoltage Fault	Input voltage is too high	Check that the line voltage is not higher than the controller rating.
		Drive deceleration time is shorter than the load can be stopped	Increase Accel/Decel pot setting by turning clockwise.
3	Motor Overload Fault	Excessive motor current	Check for mechanical problems that may be causing the overload.
			If the overload is continuous, a higher rated controller and motor may be required.
			Disconnect the motor from the controller, and check that the resistance between motor leads is within 5%. If motor windings are shorted, repair or replace the motor.
4	Low Bus Voltage Fault	Input voltage is low	Check line voltage
5	PWN Generator Fault	Internal controller fault	Shut off power, wait 5 minutes, and reapply if problem persists, replace controller.
6	Logic Fault	Internal controller fault	Shut off power, wait 5 minutes, and reapply- if problem persists, replace controller

Fault Clearing: Drive Faults may be cleared by one of the following methods:

1. Removing and reapplying power to the controller.
2. Pressing the stop button (if used).
3. Opening and closing the run contact (if used).

OPTIONS for 1/6 - 1 HP, 230 VAC Controllers

- DIN DIN RAIL MOUNTING**
A bracket which enables the BCX to be mounted on a standard 35mm DIN rail.
- RSS RUN/STOP SWITCH**
Single Pole/Single Throw slide switch. Mounts in predefined location on the BCX cover (see Figure 3.)
- 2XV 115 VAC SINGLE PHASE VOLTAGE DOUBLER**
Allows the use of 115 VAC Single Phase power to the controller. Two models are available; 1781A 1/3 HP and 1781B 1 HP.
- WBX-B CONDUIT BOX**
A bracket which provides a means of attaching a conduit connector to the basic controller. This bracket will partially cover the opening to the power and control wiring.
- WD WASHDOWN DUTY**
Provides the BCX furnished in a rugged NEMA 4/12 enclosure with an analog speed pot and a run/stop switch (WD) or with a blank front panels (WDB).

OPTIONS For 1 1/2-5 HP, 230vac & 1-5 HP, 460 VAC

- MB COMPLETE MAGNETIC BYPASS**
Bypasses the controller and connects the motor directly to the AC line. Three contactors are included and the controller is isolated in the Bypass mode. AC line disconnect with fuses and motor overload are included.

- CBH AC LINE CIRCUIT BREAKER WITH HANDLE**
Provides a three-pole magnetic trip circuit breaker as a means of manually disconnecting the drive from the AC line. The handle is cover mounted.
- LC AC LINE CONTACTOR**
Provides an AC line disconnect for the controller.
- MC MOTOR CONTACTOR**
Provides an AC output contactor that is coordinated with the controller electronics to ensure a safe, reliable shut-down and a positive disconnection of the motor from the controller.
- OR OVERLOAD RELAY**
Includes a three-pole overload relay. Motor full-load current must match listed adjustment range.
- HOA HAND-OFF-AUTO SWITCH**
Provides a three-position switch and legend plate to select between user supplied manual speed pot and an automatic speed reference.
- RSS RUN/STOP SWITCH**
Single Pole/Single Throw slide switch. Mounts in predefined location on the BCX cover (see Figure 4).
- LCO INPUT LINES CHOKES (OPEN)**
Includes an assembly with three AC line reactors (chokes rated 3% impedance) connected in series with the AC supply lines. They are furnished for separate mounting. These reactors oppose rapid line current changes and surges and help protect the controller from transients.
This option is not normally needed when a controller is connected to the AC supply through an isolation transformer. However, this option is suggested whenever;
 1. The KVA of the AC power supply is greater than three times the horsepower rating of the controller.
 2. Additional transient voltage surge protection is desirable.
 3. It is desirable to isolate inverter ripple currents from the AC line.
 4. Harmonic distortion must be reduced.
 This option should not normally be used in combination with Option LFO (Output Line Filter).
- LCE INPUT LINE CHOKES (ENCLOSED)**
This is Option LCO mounted in a NEMA 1 enclosure.
- LFO OUTPUT LINE FILTER (OPEN)**
This option filters the Ac output to provide the following benefits:
 1. Quiet motor operation at low carrier frequencies.
 2. Elimination of ground fault die to DV/DT.
 3. Reduced DV/DT stress on motor windings at higher carrier frequencies.
 4. Reduced electrical interference.
 Since this option represents a 3% output impedance, it may not be acceptable in applications characterized by low line voltage, heavy loading, and high speeds, or in combination with Option LCE (Input Line Chokes).
- LFE OUTPUT LINE FILTER (ENCLOSED)**
This is Option LFO in a NEMA 1 enclosure.
- EB ELECTRONIC BRAKING CONTROL MODULE**
Furnished in a ventilated enclosure. The braking

module is rated for stopping a typical load a maximum number of two stops per minute from motor base speed. A typical load is defined as:

1. Not exceeding rated load torque.
2. External load inertia (beyond the motor shaft) not exceeding that of the rotor. High inertia loads may extend braking times beyond the wattage rating of the power dissipation resistor. The braking circuit is not rated for continuous regeneration and should be used only where intermittent control of overhauling loads is required. The braking circuit is not a holding brake; it will not prevent a motor at rest from rotating.

WD WASHDOWN DUTY

Provides the BCX furnished in a rugged NEMA 4/12 enclosure with an analog speed pot and a run/stop switch (WD) or with a blank front panel (WDB).



Boston Gear
14 Hayward Street
Quincy, MA 02171
tel 617.328.3300
fax 617.479.6238
www.bostongear.com