



Boston Gear
14 Hayward Street
Quincy, MA 02171

tel 617.328.3300
fax 617.479.6238

ACE40UG
09/03

*** ACE 40 SERIES ***
ADJUSTABLE FREQUENCY
AC MOTOR CONTROLLERS
USER'S GUIDE
(1/4 - 600 HP)

MODEL NO. _____

SERIAL NO. _____

INPUT SUPPLY _____ VAC, 50/60 Hz

HORSEPOWER _____

These instructions do not purport to cover all details or variations in equipment, nor to provide every possible contingency to be met during installation, operation, and maintenance. If further information is desired, or if particular problems arise that are not covered sufficiently for the user's purpose, the matter should be referred to Boston Gear.

This document contains proprietary information of Boston Gear and is furnished to its customer solely to assist that customer in the installation, testing, operation, and/or maintenance of the equipment described. This document shall not be reproduced in whole or in part, nor shall its contents be disclosed to any third party without the written approval of Boston Gear.

WARNING:

This equipment contains a potential hazard of electric shock or burn. Only personnel who are adequately trained and thoroughly familiar with the equipment and these instructions should install, operate, or maintain this equipment.

Isolation of test equipment from the equipment under test presents potential electrical hazards. If the test equipment cannot be grounded to the equipment under test, the test equipment's case must be shielded to prevent contact by personnel.

To minimize hazard of electrical shock or burn, approved grounding practices and procedures must be strictly followed.

WARNING:

To prevent personal injury or equipment damage caused by equipment malfunction, only adequately trained personnel should modify any programmable machine.

Table of Contents

i. Preface

Safety Instructions	iii
ACE40 Series Model Numbering System.....	vii
ACE40 Series Dimensions & Weights	viii

1. Before Using This Drive..... 1-1

Receiving Instructions	1-1
Appearance	1-1
Handling the Product	1-2
Carrying	1-3
Storage	1-3
ACE40 Drive Ratings Efficiency & Watts Loss....	1-4

2. Installation Environment and Connection 2-1

Operating Environment	2-1
Installation Method	2-1
Connections	2-3
Basic Connection Diagrams	2-4
Connecting the Main Circuit and Ground Terminals	2-8
Connecting the Control Terminals	2-11
Terminal Configuration	2-15
ACE40 Series Cable Size, Tightening Torque & Circuit Protection Rating	2-16
DC Link Reactor	2-17

3. Operation 3-1

Inspection and Preparation Before Operation	3-1
Operation Method	3-1
Trial Run	3-1

4. Keypad Panel 4-1

Appearance of Keypad Panel	4-1
Operation From the Keypad Panel (LCD Screen, Level Structure)	4-2
Normal Operation	4-2
Alarm Modes	4-2
Entering Data on the Keypad Panel	4-4
Operation Mode	4-4
Setting Digital Frequency	4-4
Switching to LED Digital Monitor	4-5
Program Menu Screen	4-5

Setting Function Data	4-5
Checking Function Data	4-7
Monitoring Operating Status	4-7
I/O Check	4-8
Maintenance Information	4-9
Load Rate Measurement	4-10
Alarm Information	4-11
Alarm History and Factors	4-12
Data Copy	4-13
Alarm Mode	4-15

5. Function Selection 5-1

Function Select List	5-1
Alphabetical Function List	5-5
Function Explanation	5-7

6. Protective Operations 6-1

List of Protective Functions	6-1
Alarm Reset	6-2

7. Troubleshooting 7-1

Activation of Protective Function	7-1
Abnormal Motor Rotation	7-5

8. Maintenance and Inspection 8-1

Daily Inspections	8-1
Periodic Inspections	8-1
Main Circuit Measurements	8-4
Insulation Test	8-5
Replacement Parts	8-5

9. Warranty Parts and Service 9-1

In-Warranty Failure Checklist	9-2
-------------------------------------	-----

10. ACE40 Replacement Parts 10-1

11. Specifications 11-1

- Standard Specifications 11-1
- Common Specifications 11-3
- Outline Dimensions 11-5
- Keypad Mounting Hole 11-12

- 12. RS485 Modbus RTU Serial Communication**12-1
 - Transmission Specification 12-1
 - Connection 12-1
 - Serial Interface Configuration 12-1
 - Modbus RTU Functions 12-1
 - Drive function Code Access 12-2
 - Command and Monitor Data Registers 12-2
 - Data Format Specification 12-4
 - Communication Errors 12-8

- 13. Options** 13-1
 - Built-in Options 13-1

- 14. Electromagnetic Compatibility (EMC)** 14-1
 - General 14-1
 - Recommended Installation Instructions 14-1

Safety Instructions

Read this manual carefully before installing, connecting (wiring), operating, servicing, or inspecting the drive.

Be familiar with all safety features before using the drive.

In this manual, safety messages are classified as follows:

WARNING	Improper operation may result in serious personal injury or death.
CAUTION	Improper operation may result in slight to medium personal injury or property damage.

Situations more serious than those covered by CAUTION will depend on prevailing circumstances.

Always follow instructions.

Instructions on Use

WARNING

- This drive is designed to drive a 3-phase induction motor, and is not suitable for a single-phase motor or others, as fire may result.
- This drive may not be used as a component of a life-support system or other medical device directly affecting the personal welfare of the user.
- This drive is manufactured under strict quality control standards. However, safety equipment must be installed or the failure of this device may result in personal injury, property damage, or if there is a risk of accident.

Instructions on Installation

WARNING

- Mount this drive on an incombustible material such as metal, as fire may occur.
- Do not place combustible or flammable material near this drive, as fire may occur.

CAUTION

- Do not hold or carry this drive by its cover. Do not drop the drive, as injury may occur.
- Be sure the drive and heat sink surfaces are kept free of foreign matter (lint, paper dust, small chips of wood or metal, and dust), as fire or accident may occur.
- Do not install or operate a damaged drive or a drive with missing parts, as electric shock or injury may occur.

Instructions on Wiring

WARNING

- Connect the drive to power via a line-protection molded-case circuit breaker or fuse, as fire may occur. Always connect a ground wire, as electric shock or fire may occur.
- A licensed specialist must perform all wiring work, as electric shock may occur.
- Turn off the power before wiring, as electric shock may occur.
- Wire the drive after installation is complete, as electric shock or injury may occur.

CAUTION

- Confirm that the phases and rated voltage of this drive match those of the AC power supply, as injury may occur.
- Do not connect the AC power supply to the Output Terminals (U, V, and W), as injury may occur.
- Do not directly connect a braking resistor to the DC Terminals (P(+) and N(-)), as fire may occur.
- Be sure that the noise generated by the drive, motor, or wiring does not adversely affect peripheral sensors and equipment, as an accident may occur.

Instructions on Operation

WARNING

- Be sure to install the cover before turning on the power. Do not remove the cover while power to the drive is turned on. Electric shock may occur.
- Do not operate switches with wet hands, as electric shock may occur. When the retry function is selected, the drive may restart automatically after tripping. Design the machine to ensure personal safety in the event of restart. An accident may occur.
- When the torque limiting function is selected, operating conditions may differ from preset conditions (acceleration/deceleration time or speed). In this case, personal safety must be assured. An accident may occur.
- The STOP key is only effective when a function setting has been established. Install an independent emergency switch to disable the STOP key on the keypad panel when an operation is selected via the external signal terminal. An accident may occur.
- Operations can start up suddenly, after the alarm is reset, if there is a running signal input. Be sure that the running signal input is not present before resetting the alarm. An accident may occur.
- Do not touch drive terminals when energized, even if the drive has stopped. Electric shock may occur.

CAUTION

- Do not start or stop the drive using the main circuit power. Failure may occur.
- Do not touch the heat sink or braking resistor because they become very hot. Burns may occur.
- Since the drive can reach high speed operation easily, carefully check the performance of the motor or machine before changing any speed settings. Injury may occur.
- Do not use the drive braking function for mechanical holding. Injury may occur.

Instructions on Maintenance, Inspection, and Replacement

WARNING

- Wait a minimum of five minutes (30HP or less) or ten minutes (40HP or more) after power has been turned off (open) before starting inspection. Also, be sure the charge lamp is off and that DC voltage between Terminals P(+) and N(-) does not exceed 25V. Electrical shock may occur.
- Only authorized personnel should perform maintenance, inspection, and replacement operations. Remove all metal jewelry such as watches and rings. Use insulated tools only. Electric shock or injury may occur.

Instructions on Disposal

CAUTION

- Treat as industrial waste when disposing of the drive. Injury may occur.

Instructions for UL/cUL Requirements

CAUTION

- Hazard of electrical shock. Disconnect incoming power before working on this drive.
- Dangerous voltage exists until charge light is off.
- Type1 - indoor use only.
- Tightening torque and wire size for field wiring terminals are marked adjacent to the terminal or on the wiring diagram.
- The drive shall be connected with Listed Class J Fuses or Circuit Breaker rated 600V as shown in Table 2-3-5 (30HP or less).
- If auxiliary control-power input is used, connect it by referring to the basic connection diagram (2-3-1).
- Suitable for use on a circuit capable of delivering not more than 5000 rms symmetrical amperes, for 230V (230V series), 480V (460V series) maximum up to 30HP; 42000 rms symmetrical amperes 230V (230V series), 480V (460V series) maximum 40HP and above.
- Use 60/75°C CU wire only.
- A Class 2 circuit wired with Class 1 wire (30HP or less). Use Class 1 wire only (40HP or more).
- Field wiring connections must be made by a UL Listed and CSA Certified closed-loop terminal connector sized for the wire gauge involved. Connector must be fixed using the crimp tool specified by the connector manufacturer.
- Solid state motor overload protection is provided in each model.

Other Instructions

WARNING

- Never modify the drive. Electric shock or injury may occur.

Conformity to Low Voltage Directive in Europe

CAUTION

- The contact capacity of an alarm output for any fault (30A, B, C) and relay signal output (Y5A, Y5C) is 0.5A at 48 VDC, 0.3A - 250 VAC
- The ground terminal (G) should be connected to ground. Use a crimp terminal to connect a cable to the main circuit terminal or drive ground terminal.
- Where a residual-current protective device (RCD) is used for protection in case of direct or indirect contact, only a type B device is allowed on the supply side of this electrical equipment. Otherwise, another protective measure shall be applied such as separation of the electrical equipment from the environment by double or reinforced insulation or isolation of the electrical equipment and supply system by the transformer.
- Use a single cable to connect the (G) drive ground terminal. Do not use two or more drive ground terminals.
- Use a molded-case circuit breaker (MCCB) and magnetic contactor (MC) that conform to EN or IEC standards.
- Operate the drive under over-voltage Category III conditions and maintain Pollution Degree 2 or better as specified in IEC664. To maintain Pollution Degree 2 or better, install the drive in a control panel structure (level NEMA 3 or higher) which is free from water, oil, carbon, dust, etc.
- For the input-output wiring of the drive, use a cable diameter and type as specified in Appendix C in EN60204.
- To ensure safety, install an optional AC reactor, DC reactor, or external braking resistor as follows:
 - 1) Install inside an IP4X cabinet or barrier if electrical parts are exposed.
 - 2) Install inside an IP2X cabinet or barrier if electrical parts are not exposed.
- If an external cooling system is used, cover the drive rear side in order not to touch the main capacitor and braking resistor.

General Instructions

For clarity, some figures in this manual may show the drive with covers and safety screens removed for explanation purposes. Do not operate the drive until all such covers and screens have been replaced.

ACE40 Series Model Numbering System

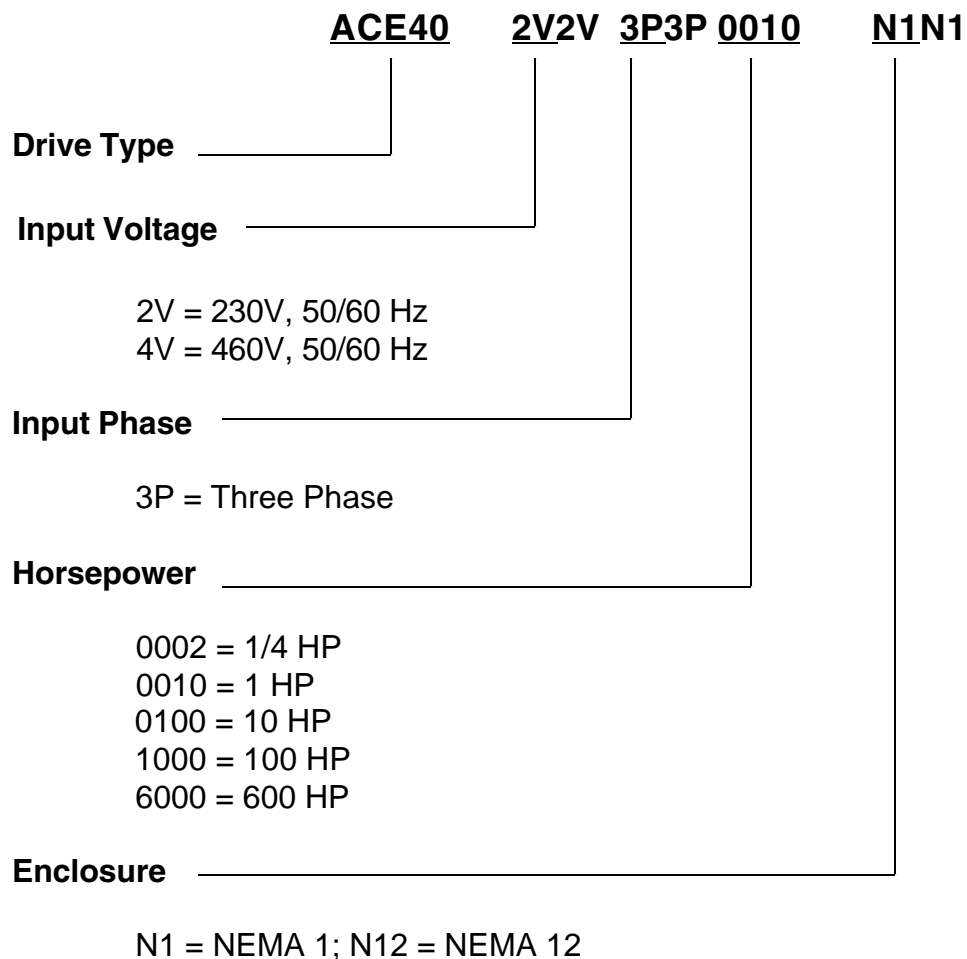

ACE40 Series Dimensions & Weights

HP Rating	NEMA Enclosure	Rated Output Current (A)	Overload (150% 1min.)	Catalog Number	Item Code	Dimensions H x W x D (inches)	Weight (lbs)
230VAC, 3 phase, 50/60Hz Input, NEMA 1							
1/4	1	1.5	2.3	ACE402V3P0002N1	43392	10.24 x 4.33 x 5.12	4.8
1/2	1	3	4.5	ACE402V3P0005N1	43393	10.24 x 4.33 x 5.12	4.8
1	1	5	7.5	ACE402V3P0010N1	43394	10.24 x 4.33 x 5.71	5.5
2	1	8	12	ACE402V3P0020N1	43395	10.24 x 5.91 x 5.71	8.4
3	1	11	17	ACE402V3P0030N1	43396	10.24 x 5.91 x 5.71	8.4
5	1	17	26	ACE402V3P0050N1	43397	10.24 x 5.91 x 5.71	8.4
7-1/2	1	25	38	ACE402V3P0075N1	43398	10.24 x 8.66 x 7.68	13.4
10	1	33	50	ACE402V3P0100N1	43399	10.24 x 8.66 x 7.68	13.4
15	1	46	69	ACE402V3P0150N1	43400	15.75 x 9.84 x 7.68	22.0
20	1	59	89	ACE402V3P0200N1	43401	15.75 x 9.84 x 7.68	22.0
25	1	74	111	ACE402V3P0250N1	43402	15.75 x 9.84 x 7.68	23.1
30	1	87	131	ACE402V3P0300N1	43403	15.75 x 9.84 x 7.68	23.1
40	1	115	173	ACE402V3P0400N1	43404	29.7 x 13.5 x 10.0	70
50	1	145	218	ACE402V3P0500N1	43405	33.1 x 14.9 x 10.6	86
60	1	180	270	ACE402V3P0600N1	43406	38.0 x 14.9 x 10.6	106
75	1	215	323	ACE402V3P0750N1	43407	38.0 x 14.9 x 10.6	110
100	1	283	425	ACE402V3P1000N1	43408	41.3 x 21.0 x 11.2	172
125	1	346	519	ACE402V3P1250N1	43409	50.4 x 26.9 x 14.2	282

230VAC, 3 phase, 50/60Hz Input, NEMA 4							
1/4	4	1.5	2.3	ACE402V3P0002N4	c/f	10.24 x 4.33 x 5.12	4.8
1/2	4	3	4.5	ACE402V3P0005N4	c/f	10.24 x 4.33 x 5.12	4.8
1	4	5	7.5	ACE402V3P0010N4	c/f	10.24 x 4.33 x 5.71	5.5
2	4	8	12	ACE402V3P0020N4	c/f	10.24 x 5.91 x 5.71	8.4
3	4	11	17	ACE402V3P0030N4	c/f	10.24 x 5.91 x 5.71	8.4
5	4	17	26	ACE402V3P0050N4	c/f	10.24 x 5.91 x 5.71	8.4
7-1/2	4	25	38	ACE402V3P0075N4	c/f	10.24 x 8.66 x 7.68	13.4
10	4	33	50	ACE402V3P0100N4	c/f	10.24 x 8.66 x 7.68	13.4

230VAC, 3 phase, 50/60Hz Input, NEMA 12							
15	12	46	69	ACE402V3P0150N12	c/f	15.75 x 9.84 x 7.68	22.0
20	12	59	89	ACE402V3P0200N12	c/f	15.75 x 9.84 x 7.68	22.0
25	12	74	111	ACE402V3P0250N12	c/f	15.75 x 9.84 x 7.68	23.1
30	12	87	131	ACE402V3P0150N12	c/f	15.75 x 9.84 x 7.68	23.1

230VAC, 3 phase, 50/60Hz Input, Open							
40	Open	115	173	ACE402V3P0400C	c/f	21.7 x 13.4 x 10.0	64
50	Open	145	218	ACE402V3P0500C	c/f	24.2 x 14.8 x 10.6	79
60	Open	180	270	ACE402V3P0600C	c/f	29.1 x 14.8 x 10.6	97
75	Open	215	323	ACE402V3P0750C	c/f	29.1 x 14.8 x 10.6	101
100	Open	283	425	ACE402V3P1000C	c/f	29.5 x 20.9 x 11.2	154
125	Open	346	519	ACE402V3P1250C	c/f	34.6 x 26.8 x 14.2	253

Notes: Horsepower rating is shown for 230V and 460V nominal systems, 1800 RPM motors.

When applying at lower voltage and lower speed AC motors, select the drive by rated current and not HP rating.

ACE40 Series Dimensions & Weights

HP Rating	NE A Enclosure	Rated output Current A	verload 150 1 inute	Catalog Number	Item Code	Dimensions H W D Inches	Weight lbs
460VAC, 3 Phase, 50/60 H Input, NE A 1							
1/2	1	1.5	2.3	ACE404V3P0005N1	43410	10.24 x 4.33 x 5.12	4.8
1	1	2.5	3.8	ACE404V3P0010N1	43411	10.24 x 4.33 x 5.71	5.5
2	1	3.7	5.6	ACE404V3P0020N1	43412	10.24 x 5.91 x 5.71	8.4
3	1	5.5	8.3	ACE404V3P0030N1	43413	10.24 x 5.91 x 5.71	8.4
5	1	9	14	ACE404V3P0050N1	43414	10.24 x 5.91 x 5.71	8.4
7-1/2	1	13	20	ACE404V3P0075N1	43415	10.24 x 8.66 x 7.68	13.4
10	1	18	27	ACE404V3P0100N1	43416	10.24 x 8.66 x 7.68	13.4
15	1	24	36	ACE404V3P0150N1	43417	15.75 x 9.84 x 7.68	22.0
20	1	30	45	ACE404V3P0200N1	43418	15.75 x 9.84 x 7.68	22.0
25	1	39	59	ACE404V3P0250N1	43419	15.75 x 9.84 x 7.68	23.1
30	1	45	68	ACE404V3P0300N1	43420	29.7 x 13.5 x 10.0	70
45	1	60	90	ACE404V3P0400N1	43421	29.7 x 13.5 x 10.0	70
50	1	75	113	ACE404V3P0500N1	43422	29.7 x 14.9 x 10.6	82
60	1	91	137	ACE404V3P0600N1	43423	34.6 x 14.9 x 10.6	95
75	1	112	168	ACE404V3P0750N1	43424	34.6 x 14.9 x 10.6	97
100	1	150	225	ACE404V3P1000N1	43425	38.0 x 14.9 x 10.6	115
125	1	176	264	ACE404V3P1250N1	43426	38.0 x 21.0 x 12.4	174
150	1	210	315	ACE404V3P1500N1	c/f	38.0 x 21.0 x 12.4	174
200	1	253	380	ACE404V3P2000N1	c/f	53.1 x 21.0 x 14.2	245
250	1	304	456	ACE404V3P2500N1	c/f	53.1 x 21.0 x 14.2	245
300	1	377	566	ACE404V3P3000N1	c/f	55.1 x 26.9 x 14.2	337
350	1	415	623	ACE404V3P3500N1	c/f	55.1 x 26.9 x 14.2	337
400	1	520	780	ACE404V3P4000N1	c/f	57.1 x 26.8 x 17.7	562
450	1	585	878	ACE404V3P4500N1	c/f	57.1 x 26.8 x 17.7	562
500	1	650	975	ACE404V3P5000N1	c/f	57.1 x 34.6 x 17.7	804
600	1	740	1110	ACE404V3P6000N1	c/f	57.1 x 34.6 x 17.7	804

Notes: Horsepower rating is shown for 460V nominal systems, 1800 RPM motors.

When applying at lower voltage and lower speed AC motors, select the drive by rated current and not HP rating.

ACE40 Series Dimensions & Weights

HP Rating	NE A Enclosure	Rated output Current A	verload 150 1 inute	Catalog Number	Item Code	Dimensions H W D Inches	Weight lbs
460VAC, 3 Phase, 50/60 H Input, NE A 4							
1/2	4	1.5	2.3	ACE404V3P0005N4	c/f	10.24 x 4.33 x 5.12	4.8
1	4	2.5	3.8	ACE404V3P0010N4	c/f	10.24 x 4.33 x 5.71	5.5
2	4	3.7	5.6	ACE404V3P0020N4	c/f	10.24 x 5.91 x 5.71	8.4
3	4	5.5	8.3	ACE404V3P0030N4	c/f	10.24 x 5.91 x 5.71	8.4
5	4	9	14	ACE404V3P0050N4	c/f	10.24 x 5.91 x 5.71	8.4
7-1/2	4	13	20	ACE404V3P0075N4	c/f	10.24 x 8.66 x 7.68	13.4
10	4	18	27	ACE404V3P0100N4	c/f	10.24 x 8.66 x 7.68	13.4
460VAC, 3 Phase, 50/60 H Input, NE A 12							
15	12	24	36	ACE404V3P0150N12	c/f	15.75 x 9.84 x 7.68	22.0
20	12	30	45	ACE404V3P0200N12	c/f	15.75 x 9.84 x 7.68	22.0
25	12	39	59	ACE404V3P0250N12	c/f	15.75 x 9.84 x 7.68	23.1
30	12	45	68	ACE404V3P0300N12	c/f	21.7 x 13.4 x 10.1	64
460VAC, 3 Phase, 50/60 H Input, pen							
40	1	60	90	ACE404V3P0400C	c/f	21.7 x 13.4 x 10.1	64
50	1	75	113	ACE404V3P0500C	c/f	21.7 x 14.8 x 10.6	75
60	1	91	137	ACE404V3P0600C	c/f	26.6 x 14.8 x 10.6	86
75	1	112	168	ACE404V3P0750C	c/f	26.6 x 14.8 x 10.6	88
100	1	150	225	ACE404V3P1000C	c/f	29.1 x 14.8 x 10.6	106
125	1	176	264	ACE404V3P1250C	c/f	29.1 x 20.9 x 12.4	154
150	1	210	315	ACE404V3P1500C	c/f	29.1 x 20.9 x 12.4	154
200	1	253	380	ACE404V3P2000C	c/f	39.4 x 20.9 x 14.2	220
250	1	304	456	ACE404V3P2500C	c/f	39.4 x 20.9 x 14.2	220
300	1	377	566	ACE404V3P3000C	c/f	39.4 x 26.8 x 14.2	308
350	1	415	623	ACE404V3P3500C	c/f	39.4 x 26.8 x 14.2	308
400	1	520	780	ACE404V3P4000C	c/f	55.1 x 26.8 x 17.7	551
450	1	585	878	ACE404V3P4500C	c/f	55.1 x 26.8 x 17.7	551
500	1	650	975	ACE404V3P5000C	c/f	55.1 x 35.5 x 17.7	793
600	1	740	1110	ACE404V3P6000C	c/f	55.1 x 35.5 x 17.7	793

Notes: Horsepower rating is shown for 460V nominal systems, 1800 RPM motors.

When applying at lower voltage and lower speed AC motors, select the drive by rated current and not HP rating.

1. Before Using This Drive

1.1 Receiving Instructions

Unpack and check the drive as explained below.

If you have any questions about the drive, contact Boston Gear or your local distributor.

1. Check the ratings nameplate to confirm that the delivered drive is the one that was ordered.
2. Check for damaged and/or missing parts upon delivery.
3. In addition to the drive and this manual, the package contains rubber bushings (for products with 30HP or less) and a terminating resistor (1/2 W, 120 ohms). The terminating resistor for drives 30HP or less is packaged separately. The terminating resistor for drives 40HP or more are installed inside the drive. To connect the internal terminating resistor, place hardware Jumper J2 in the "ON" position. This terminating resistor is required for RS485 RTU communication.
4. On drives rated 100HP and larger, a separately mounted DC Link Reactor is provided. The reactor should be checked for proper rating before installation.

1.2 Appearance



1.3 Handling the Product

(1) Removing the Cover

For drives 30HP or less, loosen the cover mounting screws, then remove the cover by pulling from the top (see Figure 1.3.1).

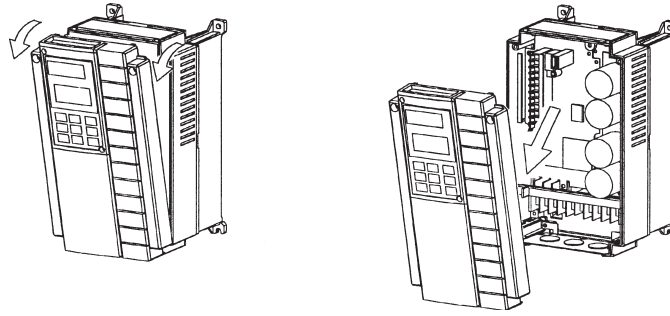

Fig.1-3-1 Removing the Cover (for drives 30HP or less)

For drives 40HP or more, first remove the six cover mounting screws, then remove the cover.

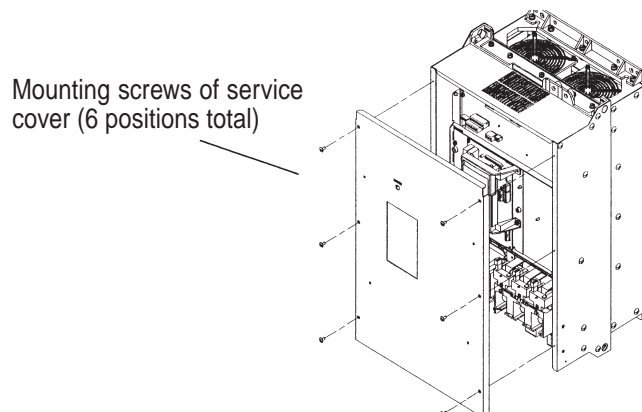

Fig.1-3-2 Removing the Cover (for drives 40HP or more)

(2) Removing the Keypad Panel

After removing the cover as explained in (1), loosen the keypad panel mounting screws and remove as shown in Figure 1.3.3 for drives 40HP or less.

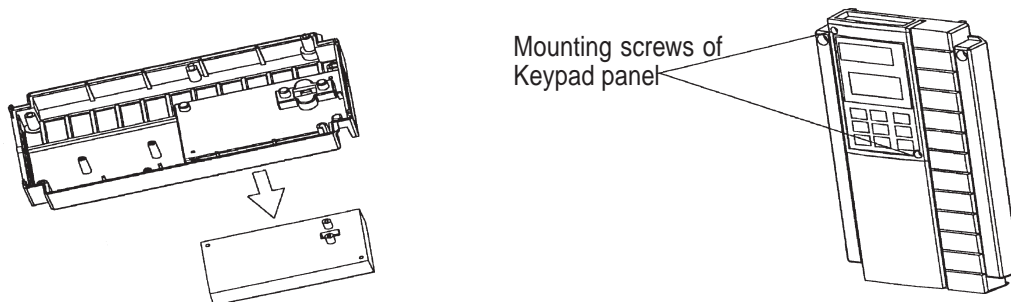

Fig.1-3-3 Removing the Keypad Panel (for drives 30HP or less)

For drives 40HP or more, loosen the keypad panel mounting screws and remove, using the finger holds on the keypad panel case.

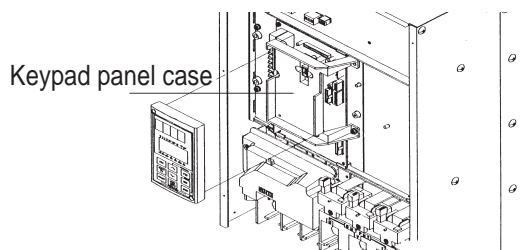

Fig.1-3-4 Removing the Keypad Panel (for drives 40HP or more)

1.4 Carrying

Carry the drive by the main unit. Do not carry the drive by its cover or parts other than the main unit. Use a crane or hoist to carry a drive equipped with hanging holes.

1.5 Storage

Temporary Storage

Temporary storage of this drive must meet the conditions listed in Table 1-5-1.

Table 1-5-1 Storage Environment

Item		Specifications
Ambient Temperature	-10° to +50°C (+14° to +122°F)	Condensation or freezing, as a result of sudden temperature changes, must not occur.
Storage Temperature	-25° to +65°C ¹ (-4° to +149°F)	
Relative Humidity	5 to 95% ²	
Atmosphere	The standard product must not be exposed to dust, direct sunlight, corrosive gas, flammable gas, oil mist, vapor, water drops, or vibration. The salt content in the atmosphere should be minimized.	

Note 1: The storage temperature applies only to short periods of time, such as during transport. Refer to comments on long-term storage guidelines.

Note 2: Since a large change in temperature within this humidity range may result in condensation or freezing, do not store the drive where such temperature changes may occur.

1. Do not place this drive directly on the floor.
2. To store the drive in an extreme environment, packed in vinyl sheeting, etc.
3. If the drive is stored in a high-humidity environment, insert a drying agent (e.g., silica gel) and pack the drive in vinyl sheeting.

Long-term Storage

If the drive is to be stored for an extended period of time after purchase, the method of storage depends primarily on the storage location.

The general long-term storage method is as follows:

1. The above conditions for temporary storage must be satisfied. If the storage period exceeds three months, the upper limit of ambient temperature must be reduced to 30°C (86°F) to prevent the deterioration of the electrolytic capacitors.
2. Pack the drive thoroughly to eliminate exposure to moisture and include a drying agent to ensure a relative humidity of 70% or less.
3. Do not leave the drive mounted in a control panel and exposed to the elements like moisture or dust (particularly on a construction site). In this case, remove the drive and store it in a suitable environment.
4. Electrolytic capacitors will deteriorate if not provided with power for an extended period of time. Do not store electrolytic capacitors for one year or longer without providing power.

1.6 ACE40 Drive Ratings Efficiency and Watts Loss

HP Rating	Rated Output Current (A)	Rated Output Power (KVA)	Efficiency at 2KHz (%)	Efficiency at 15KHz (%)	Watts Loss at 2KHz (W)	Watts Loss at 15KHz (W)	Internal DB (W)
230VAC							
0.25	1.5	0.59	92.0	90.5	25	30	10
0.5	3	1.1	93.5	91.7	35	45	10
1	5	1.9	94.9	94.0	50	60	10
2	8	3.1	95.7	94.1	80	110	30
3	11	4.3	95.9	94.9	110	140	30
5	17	6.7	96.2	95.4	170	210	30
7.5	25	9.9	96.2	95.2	240	310	60
10	33	13	96.5	95.3	300	415	60
15	46	18	96.4	95.2	450	620	N/A
20	59	23	96.9	95.9	540	720	N/A
25	74	29	96.8	95.8	670	890	N/A
30	87	34	96.5	95.5	880	1160	N/A
40	115	45	97.2	96.5	950	1200	N/A
50	145	57	97.2	96.4	1200	1550	N/A
60	180	71	97.3	96.6	1400	1750	N/A
75	215	85	97.4	96.8	1600	2050	N/A
			2KHz (%)	10KHz (%)	2KHz (W)	10KHz (W)	
100	283	112	97.4	97.0	2150	2500	N/A
125	346	137	97.4	97.0	2600	3000	N/A
460VAC							
0.5	1.5	1.1	93.5	89.3	35	60	10
1	2.5	1.9	95.4	91.7	45	85	10
2	3.7	2.9	96.7	94.1	60	110	30
3	5.5	4.3	97.0	94.5	80	150	30
5	9	7.1	97.1	95.0	130	230	30
7.5	13	10	97.3	95.3	170	300	60
10	18	14	97.3	95.4	230	400	60
15	24	19	97.6	95.9	300	520	N/A
20	30	23	97.9	96.5	360	610	N/A
25	39	31	97.8	96.4	460	770	N/A
30	45	35	97.8	96.4	550	900	N/A
40	60	47	97.8	96.4	750	1250	N/A
50	75	59	97.7	96.1	950	1650	N/A
60	91	72	97.8	96.4	1100	1850	N/A
75	112	89	97.9	96.5	1300	2200	N/A
			2KHz (%)	10KHz (%)	2KHz (W)	10KHz (W)	
100	150	119	98.1	97.2	1550	2350	N/A
125	176	140	98.0	97.2	1950	2800	N/A
150	210	167	98.0	97.3	2400	3350	N/A
200	253	202	98.2	97.3	2650	3900	N/A
250	304	242	98.1	97.3	3250	4700	N/A
300	377	300	98.2	97.4	3900	5750	N/A
350	415	330	98.2	97.4	4350	6300	N/A
400	520	414	98.2	97.4	5450	7950	N/A
450	585	466	98.2	97.4	6150	8950	N/A
500	650	518	98.3	97.4	6700	9950	N/A
600	740	590	98.2	97.4	7750	11300	N/A

2. Installation Environment and Connection

2.1 Operating Environment

Install the drive in a location that meets the conditions listed in Table 2-1-1.

Table 2-1-1 Operating Environment

Item	Specifications
Location	Indoors
Ambient Temperature	-10° to +50°C (+14° to +122°F) - for products of 30 HP or less, the ventilating covers must be removed if ambient temperature exceeds +40°C (104°F), NEMA Type 4 & 12 Unit -10° to +40°C (+14° to +104°F)
Relative Humidity	5 to 95% (No condensation).
Atmosphere	The product must not be exposed to dust, direct sunlight, corrosive gas, oil mist, vapor, or water. There must be a minimum salt content in the atmosphere. Do not store where condensation may occur as a result of sudden changes in temperature.
Altitude	1000 m (3300 feet) or lower - For altitude above 1000 m (3300 feet), see Table 2-1-2.
Vibration	3mm peak from 2 to 9Hz, 9.8m/s2 from 9 to 20Hz, 2m/s2 from 20-55Hz, 1m/s2 from 55 to 200Hzs.

CAUTION

Be sure that the drive and heat sink surfaces are kept free of foreign matter such as lint, paper dust, small chips of wood or metal, and dust. **Fire or accident may occur.**

Table 2-1-2 Output current reduction rate based on altitude

Altitude	Output current reduction rate
3300 feet (1000m or lower)	1
3300-4950 feet (1000-1500m)	0.97
4950-6600 feet (1500-2000m)	0.95
6600-8250 feet (2000-2500m)	0.91
8250-9900 feet (2500-3000m)	0.88

2.2 Installation Method

- Securely fasten the drive in an upright position on a solid structure with the ACE40 tag facing the front. Do not turn the drive upside down or install it in a horizontal position. See Fig. 2-2-1
- Since heat is generated during drive operation, the spaces shown in Fig. 2-2-1 are required to ensure sufficient cooling. Do not install the drive beneath a device sensitive to heat, as heat radiates upward.
- The heat sink may reach a temperature of 90°C (+194°F) during drive operation. Ensure that the material surrounding the drive can withstand this temperature.

WARNING

Install the drive on nonflammable material such as metal.

- When installing the drive in a control panel, consider ventilation to prevent the drive's ambient temperature from exceeding the specified value. Do not install the drive in an area from which heat cannot be sufficiently released.
- If two or more drives must be installed in the same device or control panel, arrange the units horizontally to minimize the effect of heat. If two or more drives must be installed vertically, place an insulated plate between the drives to minimize the effect of heat.
- When shipped from the factory, drives provide internal cooling inside the panel. A drive of 30HP or less can be converted to external cooling simply by adding an optional mounting adapter.

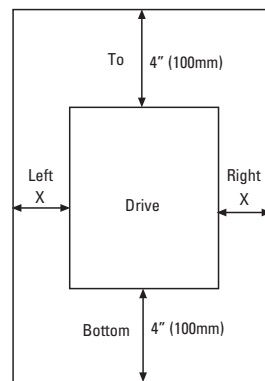

Fig. 2-2-1 30HP or less: Gap X can be 0. (side-by-side installation) 40HP or more: Gap X >= 2.0" (50mm)

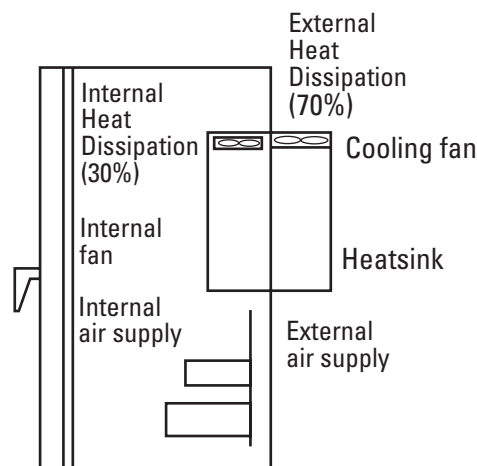

Fig. 2-2-2 Through Panel Mount

ACE40UG

A drive of 40HP or more can be converted to external cooling simply by moving the upper and lower mounting brackets as shown in Fig. 2-2-3. Remove the M6 bracket screws, move the brackets, then secure the brackets using the M5 case mounting screws. (The bracket screws are no longer required after changing the bracket mounting position.)

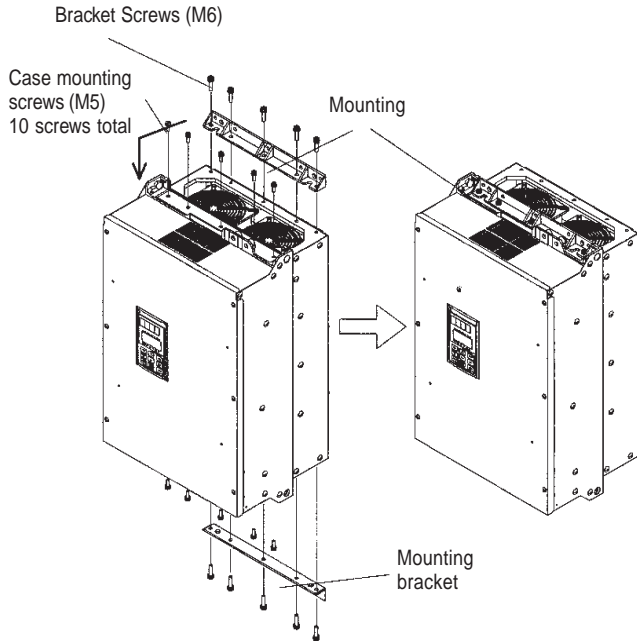

Fig. 2-2-3

In an external cooling system, a heat sink radiating about 70% of total drive heat (total loss) can be placed outside the device or control panel, as shown in Fig. 2-2-2.

7. For drives 30HP or less, remove the ventilating covers if ambient temperature exceeds +40°C (104°F).

1. Removing the Ventilating Covers

One ventilating cover is mounted on top of the drive and two or three are mounted at the bottom. Remove the main cover and then remove ventilating covers by popping out the cover inserts as shown in Fig. 2-2-4.

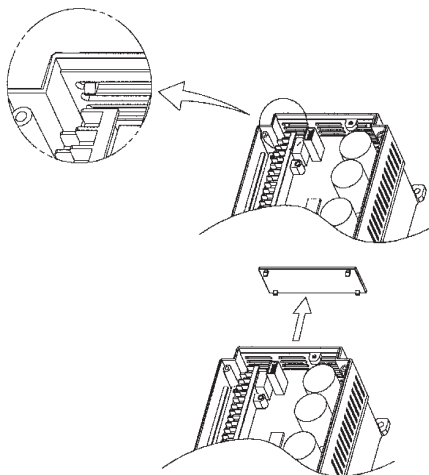

Fig. 2-2-4 Removing the ventilating cover

Installation of Open Type with NEMA 12 Heat Sink Drive (40HP and above)

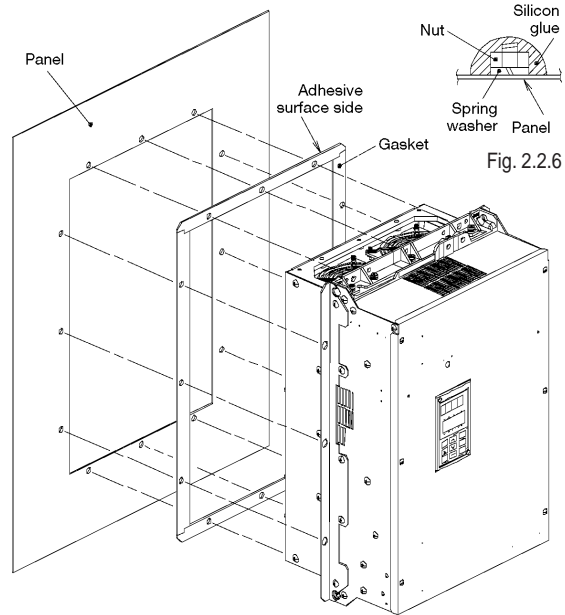

Fig.2.2.5

1. Remove the adhesive protection strip from the gasket and then mount the gasket to a panel/enclosure, carefully aligning cutout and mounting holes.
2. Install the drive and tighten the mounting bolt and nut. (Tightening torque: 119 lbs-inch [M8], 425 lbs-inch [M12]). Mounting hardware to be supplied by the customer. (Refer to Fig. 2.2.5)
3. After proper torque has been applied to all mounting hardware, seal the outside end of the hardware with silicon glue. Silicon glue to be supplied by the customer. (Refer to Fig. 2.2.6)

2.3 Connections

Remove the main cover before connecting the terminal blocks, as follows.

2-3-1 Basic Connections

1. Always connect power to the L1/R, L2/S, and L3/T main circuit power terminals on the drive. Connecting power to other terminals will damage the drive. Check that the power voltage is within the maximum allowable voltage marked on the nameplate, etc.
2. Always wire the ground terminal to ground to prevent problems such as fire or electric shock and to minimize noise.
3. Use a reliable crimp terminal for connection between a power terminal and a power wire.
4. After terminating the wiring connection, confirm the following:
 - a. Confirm that the connection is correct.
 - b. Confirm that all necessary connections have been made.
 - c. Confirm that there is no short-circuit or ground fault between the terminals and wire.
5. Connection modification after power-on

The smoothing capacitor in the direct current portion of the main circuit cannot be discharged immediately after the power is turned off. To ensure safety, use a multimeter to check that the direct current (DC) voltage is lowered to the safety range (25 VDC or less) after the charge lamp goes off. Also, confirm that the voltage is zero before short-circuiting. The residual voltage (electric charge) may cause sparks.

WARNING

Always connect a ground wire. Electric shock or fire may occur. Ensure that a trained specialist performs all wiring. Confirm that the power is turned off (open) before beginning any wiring operations. Electrical shock may occur.

2.3.1 Basic Connection Diagram (Sink Logic)

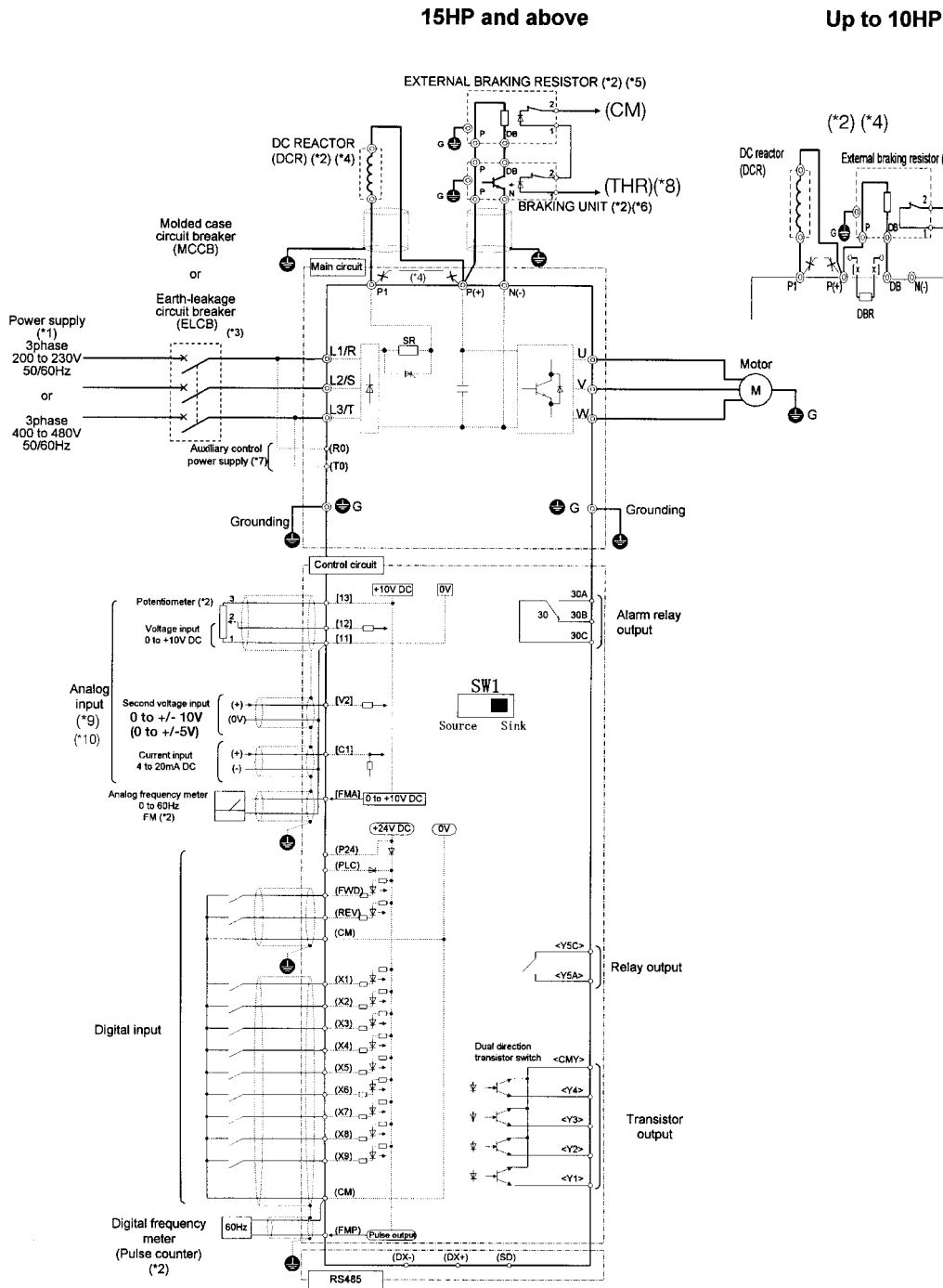

Notes: The control circuit common Terminals [11], (CM) and <CMY> are isolated.

(*1) Use a drive with rated voltage matching the power supply voltage.

(*2) Use as required.

(*3) Use this peripheral device when necessary.

(*4) Remove the jumper Wire (*4) between P1 and P(+) before connecting a DC REACTOR.

(*5) Be sure to use the braking unit (option)(*6) when connecting the external braking resistor (option)(*5).

(*6) Connect the braking unit to P(+) and N(-). The auxiliary Terminals [1] and [2] have polarity. Connect them as shown in the figure above.

(*7) The drive can be operated without connecting the auxiliary control power supply.

(*8) Terminals (X1) to (X9) can be set to 9 (THR) - Braking unit thermal trip input.

(*9) If using V2 or C1 as a reference signal, they must be used exclusively.

(*10) It is possible to input voltage signals (0 to +10 VDC or 0 to +5 VDC) to Terminals [12] [11] instead of the potentiometer.

Basic Connection Diagram to PLC (Sink Logic)

15HP and above

Up to 10HP

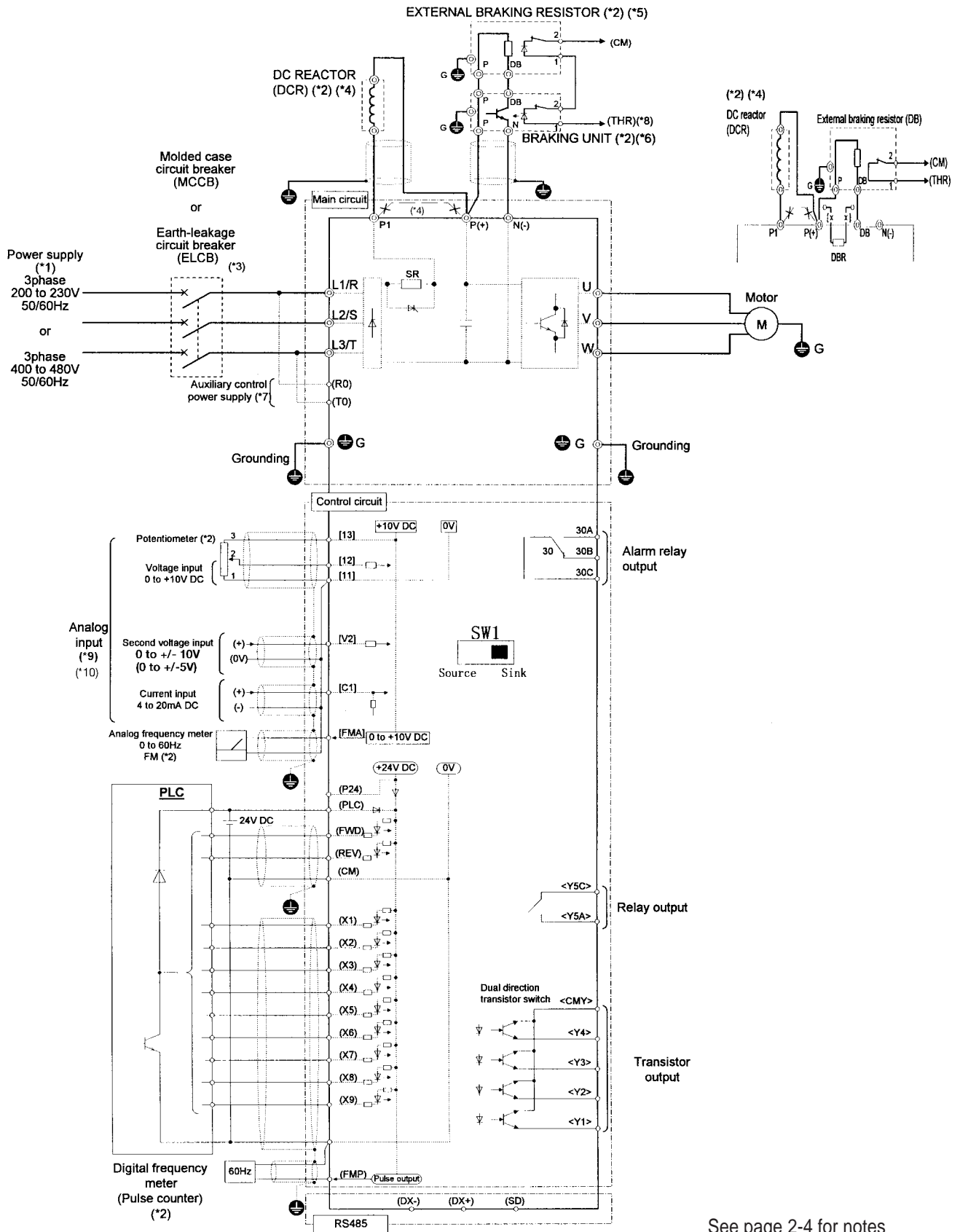

See page 2-4 for notes

Basic Connection Diagram (Source Logic, Typically used in Europe)

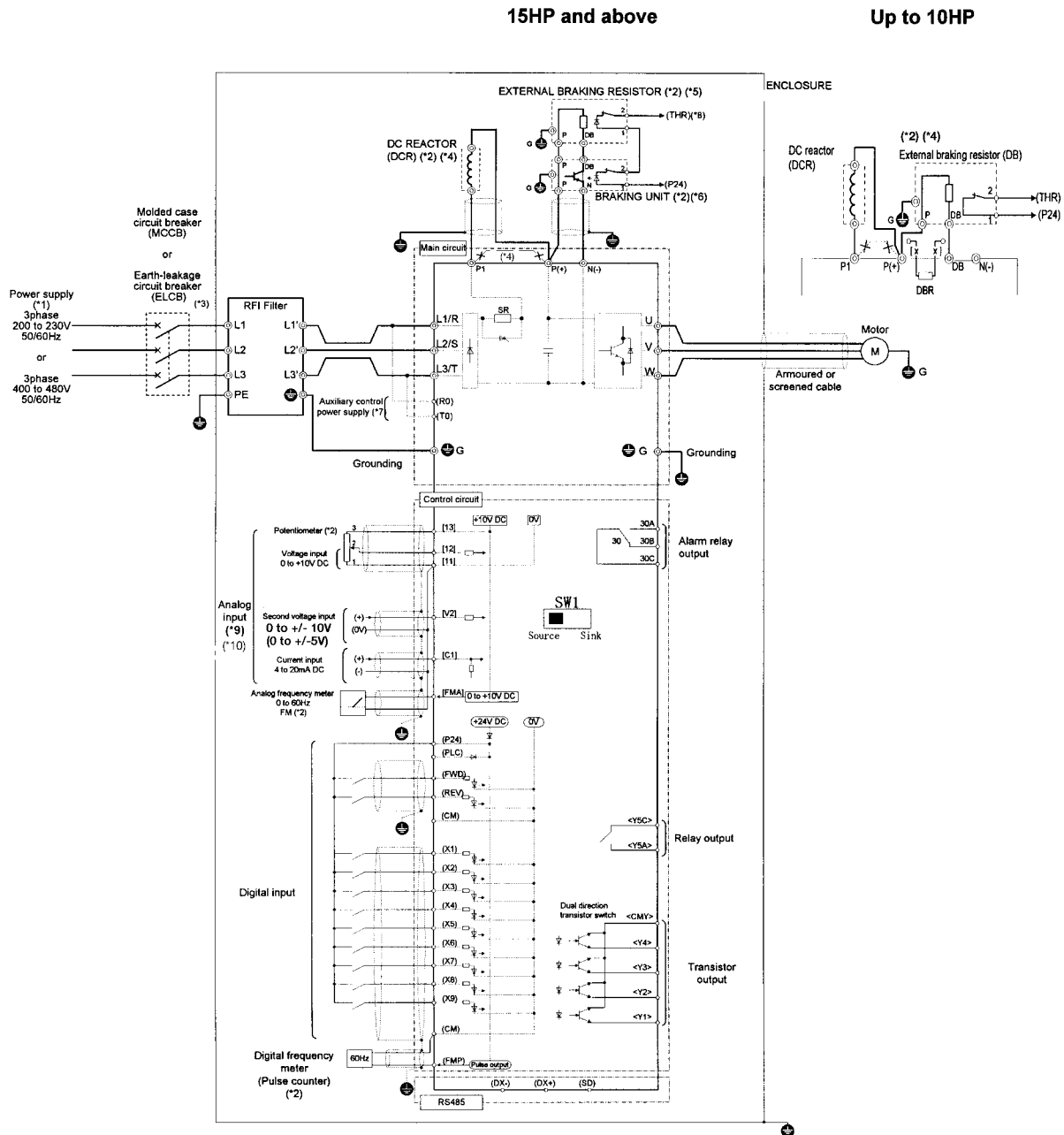

Notes: The control circuit common Terminals [11], (CM) and <CMY> are isolated.

(*1) Use a drive with rated voltage matching the power supply voltage.

(*2) Use as required.

(*3) Use this peripheral device when necessary.

(*4) Remove the jumper Wire (*4) between P1 and P(+) before connecting a DC REACTOR.

(*5) Be sure to use the braking unit (option)(*6) when connecting the external braking resistor (option)(*5).

(*6) Connect the braking unit to P(+) and N(-). The auxiliary Terminals [1] and [2] have polarity. Connect them as shown in the figure above.

(*7) The drive can be operated without connecting the auxiliary control power supply.

(*8) Terminals (X1) to (X9) can be set to 9 (THR) - Braking unit thermal trip input.

(*9) If using V2 or C1 as a reference signal, they must be used exclusively.

(*10) It is possible to input voltage signals (0 to +10 VDC or 0 to +5 VDC) to Terminals [12] [11] instead of the potentiometer.

Basic Connection Diagram to PLC (Source logic, Typically used in Europe)

15HP and above

Up to 10HP

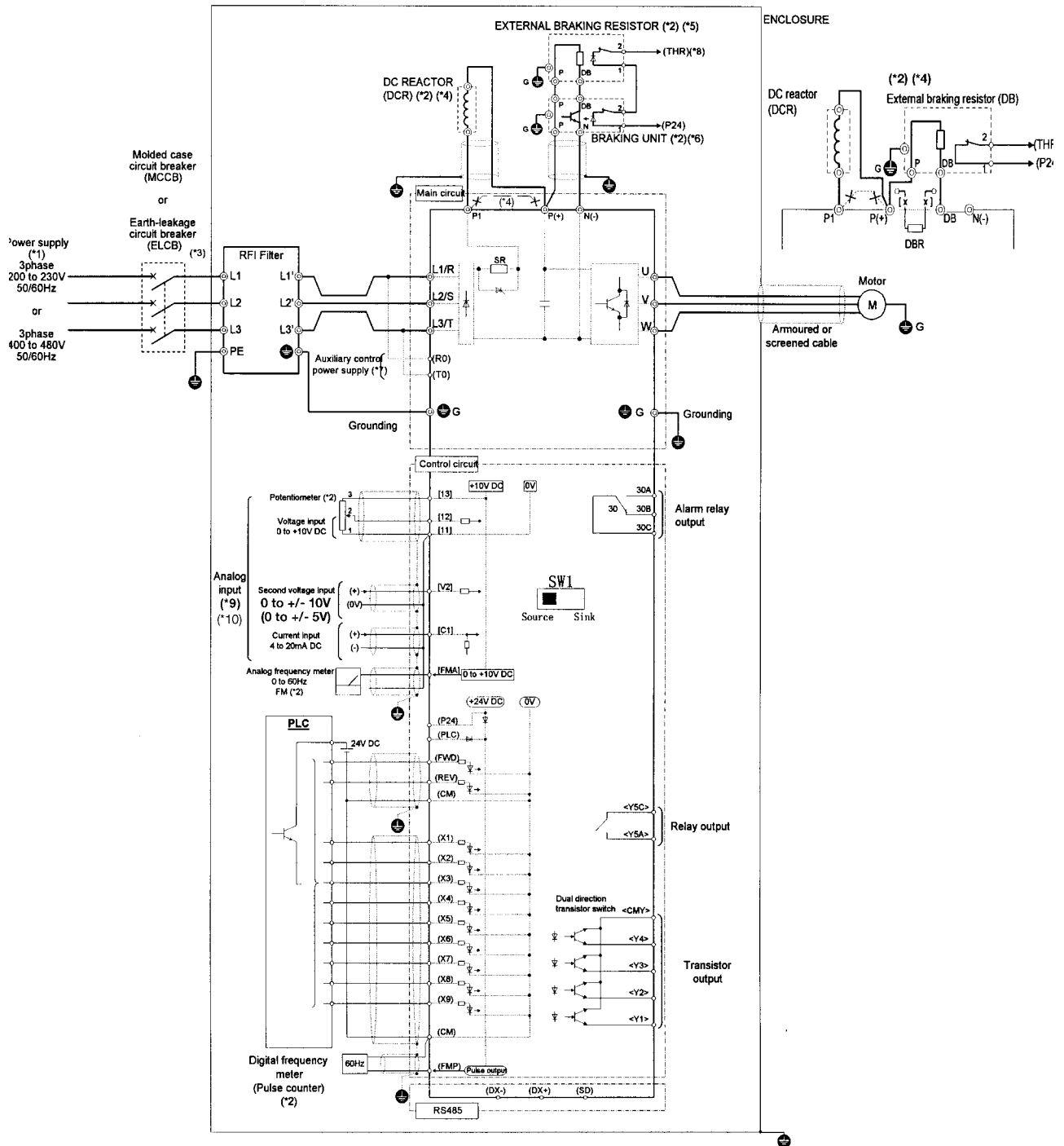

See page 2-4 for notes

2.3.2 Connecting the Main Circuit and Ground Terminals

Table 2.3.1 Functions of main circuit terminals and ground terminals

Symbol	Terminal Name	Description
L1/R,L2/S,L3/T	Main circuit power terminals	Connects a 3-phase power supply
U,V,W	Inverter output terminals	Connects a 3-phase motor
R0,T0	Input terminals for auxiliary control power	Connects a backup AC power supply to the circuit (not supported for drives of 1 Hp or less)control
P1,P(+)	DC reactor terminals	Connects the optional power correcting DC reactor
P(+),DB	Terminals for external braking resistor	Connects the optional external braking resistor (for drives of 10 Hp or less)
P(+),N(-)	Terminals for DC link circuit	Supplies DC link circuit voltage to the external braking unit (option) or power regeneration unit (option).
G	Ground terminal	Connects the drive chassis (case) to ground.

(1) Main circuit power terminals (L1/R, L2/S, L3/T)

1. Connect these terminals to the power supply via a molded-case circuit breaker or ground-leakage circuit breaker for circuit protection. Phase-sequence matching is not necessary.
2. To ensure safety, a magnetic contactor should be used to disconnect the drive from the power supply when the drive protective function activates.
3. Use control circuit Terminal FWD/REV or the RUN/STOP key on the keypad panel to start or stop the drive. The main circuit power should be used to start or stop the drive only if absolutely necessary and then should not be used more than once every hour.
4. If you need to connect these terminals to a single-phase power supply, please contact the factory.

(2) Drive output terminals (U, V, W)

1. Connect these terminals to a 3-phase motor in the correct phase sequence. If the direction of motor rotation is incorrect, exchange any two of the U, V, and W phases.
2. Do not connect a power factor correction capacitor or surge absorber to the drive output.
3. If the cable from the drive to the motor is very long, a high-frequency current may be generated by stray capacitance between the cables, and result in an overcurrent trip of the drive, an increase in leakage current, or a reduction in current indication precision.

When a motor is driven by a PWM-type drive, the motor terminals may be subject to surge voltage generated by drive element switching. If the motor cable (with 460V series motors, in particular) is particularly long, surge voltage will deteriorate motor insulation. To prevent this, use the following guidelines:

Drives 7.5 HP and larger			
Motor Insulation Level	1000V	1300V	1600V
460 VAC Input Voltage	66 ft (20 m)	328 ft (100 m)	1312 ft (400 m) *
230 VAC Input Voltage	1312 ft (400 m) *	1312 ft (400 m) *	1312 ft (400 m) *

Drives 5 HP and smaller			
Motor Insulation Level	1000V	1300V	1600V
460 VAC Input Voltage	66 ft (20 m)	165 ft (50 m) *	165 ft (50 m) *
230 VAC Input Voltage	328 ft (100 m) *	328 ft (100 m) *	328 ft (100 m) *

* For this case the cable length is determined by secondary effects and not voltage spiking.

Note: When a motor protective thermal O/L relay is inserted between the drive and the motor, the thermal O/L relay may malfunction (particularly in the 460V series), even when the cable length is 165 feet (50m) or less. To correct, insert a filter or reduce the carrier frequency. (Use function code "F26 Motor sound.")

(3) Input terminals for auxiliary control power (R0 and T0)

The drive operates even if power is not provided to these terminals. If a protective circuit operates, and the magnetic contactor on the drive's power is opened (off), the drive control circuit power, the alarm output (30A, B, and C), and the keypad panel display go off. To prevent this, the main circuit AC power must also be supplied as auxiliary control power to the auxiliary control power input Terminals (R0 and T0).

1. To ensure effective noise reduction when using a radio noise filter, the output power from the filter must go to the auxiliary control power input terminals. If these terminals are connected to the input side of the filter, the noise reduction effect deteriorates.

(4) DC reactor terminals (P1 and P(+))

1. Before connecting a power factor correcting DC reactor (optional) to these terminals, remove the factory-installed jumper.
2. If a DC reactor is not used, do not remove the jumper.

Note: For drives of 100HP or more, the DC reactor is provided as a separate standard component and should always be connected to the terminals. The DC reactor is provided as open type, enclosure to be provided by others.

CAUTION

A DC reactor does not come with drives rated less than 100HP, however, use a DC reactor or AC reactor under the following conditions, otherwise the drive may be damaged or malfunction.

- 1) Use when the capacity of the power supply transformer exceeds 500 kVA and exceeds the rated capacity of the drive tenfold.
2. Use when a thyristor converter is connected as a common load on the same transformer.
3. Use to prevent a drive OV trip from occurring when the power factor capacitor in the power line is switched on and off.
4. Use when the voltage imbalance exceeds 3%.

$$\text{Imbalance rate between phase [\%]} = \frac{(\text{Max. voltage [V]} - \text{Min. voltage [V]})}{\text{3-phase average voltage [V]}} \times 100\%$$

(5) Terminals for external braking resistor (P(+) and DB) (10 Hp or less)

For drives of 10HP or less, a built-in braking resistor is connected to Terminals P(+) and DB. If this braking resistor does not provide sufficient thermal capacity (e.g., in highly repetitive operation or heavy inertia load operation), an external braking resistor (option) must be mounted to improve braking performance.

1. Remove the built-in braking resistor from Terminals P(+) and DB. Insulate the resistor-removed terminals with adhesive insulation tape, etc.
2. Connect Terminals P(+) and DB on the external braking resistor to Terminals P(+) and DB on the drive.
3. The wiring length (twisted pair cables, etc.) should

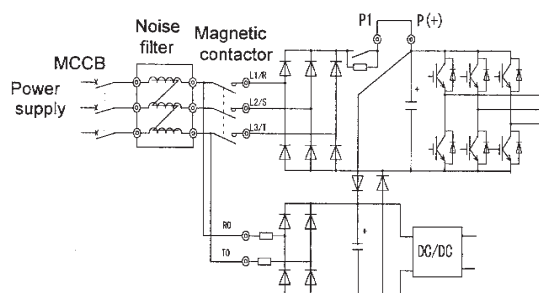

Fig. 2-3-2 Connections to the auxiliary control-power input terminals

not exceed 16.5 feet (5m).

(6) Terminals for DC link circuit (P(+) and N(-))

ACE40 Series drives of 15HP or more, do not contain a drive circuit for the braking resistor. To improve braking performance, an external braking unit (option) and an external braking resistor (option) must be installed.

1. Connect Terminals P(+) and N(-) on the braking unit to Terminals P(+) and N(-) on the drive. The wiring length (twisted pair cables, etc.) should not exceed 16.5 feet (5m).
2. Connect Terminals P(+) and DB on the braking resistor to Terminals P(+) and DB on the braking unit. The wiring length (twisted pair cables, etc.) should not exceed 33 feet (10m). If Terminals P(+) and N(-) on the drive are not used, leave the terminals open. If P(+) is connected to N(-), or the braking resistor is connected directly, the resistor will burn up.
3. Auxiliary contacts 1 and 2 of the braking unit have polarity.
4. Refer to DB unit instruction book for paralleled resistors.

Note: Braking units and resistors are rated on degree of braking, duration and system frequency of braking cycle. Verify that the units meet application requirements.

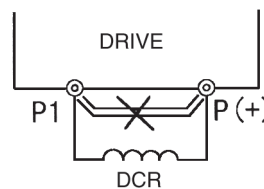

Fig. 2-3-3

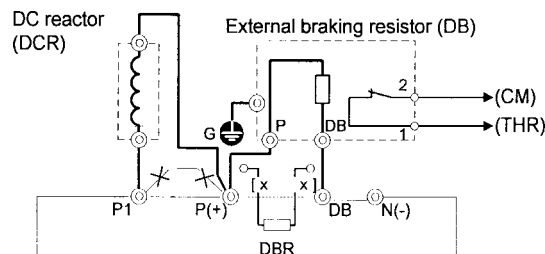

Fig. 2-3-4 Connection (10HP or less)

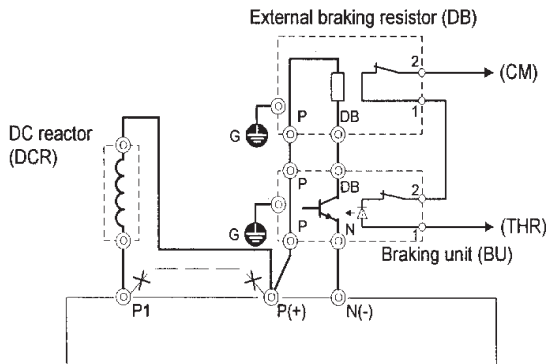

Fig. 2-3-5 Connections 15HP or more, 100HP or more parallel resistors, 200HP or more parallel braking units.

(7) Ground terminal

The grounding connector should be sized in accordance with the NEC or Canadian Electrical Code. The connection should be made by a UL listed or CSA certified closed-loop terminal connector sized for the wire gauge involved. The connector is to be fixed using the crimp tool specified by the connector manufacturer.

(8) Auxiliary power switching connector (CN UX) (for drives of 40HP or more)

When a drive of 40HP or more requires main circuit power voltage as listed in Table 2-3-2, disconnect the auxiliary power switching Connector CN UX from U1 and connect to U2. For the switching method, see Fig. 2-3-7.

Table 2-3-2 Main Voltage Requiring Auxiliary Power Switching Connector

Frequency [Hz]	Power Voltage Range [VAC]
50	380 - 398
60	380 - 430

CAUTION

- Check that the number of phases and rated voltage match those of the AC power supply.
- Do not connect the AC power supply to the output Terminals (U, V, W). Injury may occur.
- Do not directly connect a braking resistor to the DC Terminals (P[+] and N[-]). Fire may occur.

The switching connectors are mounted on the power PCB above the control PCB as shown on the right.

Note: To remove a connector, unlock the connector (using the locking mechanism) and pull. To install, firmly push the connector until it click locks.

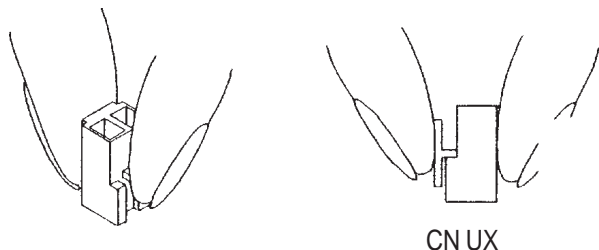

<Enlarged view of part A>

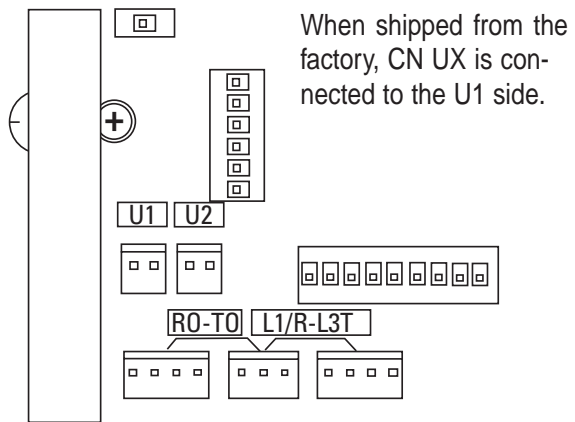

<3D view of part A>

Factory Shipment Status Connector CN UX: U1

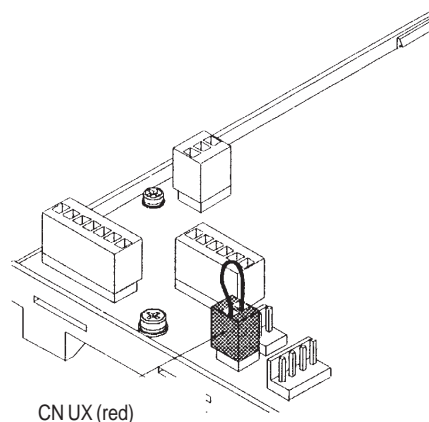
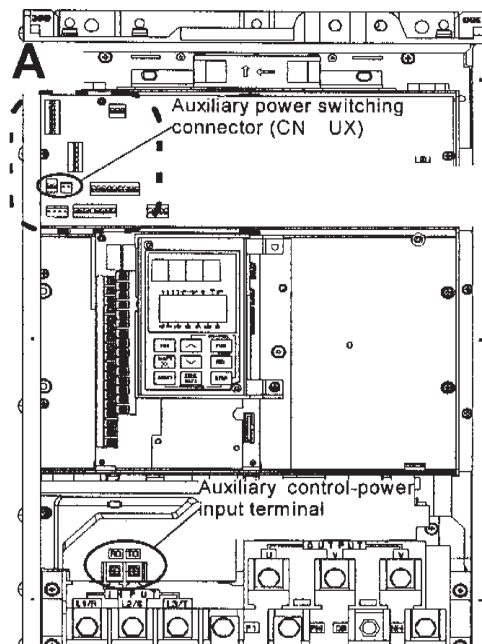

2.3.3 Connecting the Control Terminals

Table 2.3.3 lists the functions of the control circuit terminals. A control circuit terminal should be connected according to its function setting.

Table 2-3-3

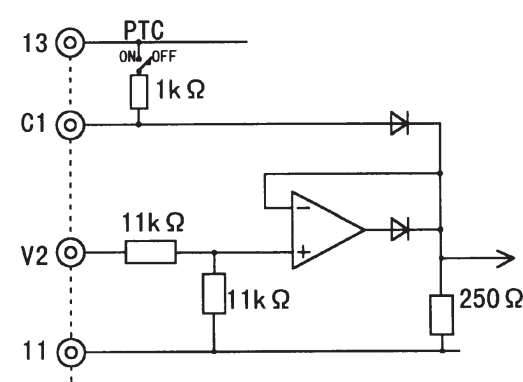
Classification	Terminal Symbol	Terminal Name	Function
Analog input	13	Potentiometer power supply	Used for +10 VDC power supply for frequency setting POT (resistance of 1 to 5k ohms)
	12	Voltage input	<ol style="list-style-type: none"> Frequency is set according to the analog input voltage supplied from an external circuit. <ul style="list-style-type: none"> - 0 to +10 VDC / 0 to 100% - Reverse operation using positive and negative signals: 0 to +/- 10 VDC / 0 to 100% - Reverse operation: +10 to 0 VDC / 0 to 100% Input feedback signal for PID control is input. The analog input value from the external circuit is used for torque control. <p>* Input resistance: 22k ohms</p>
	V2	Voltage input supplied from an external circuit.	<p>* Frequency is set according to the analog input voltage</p> <ul style="list-style-type: none"> - 0 to +10 VDC/0 to 100% - Reverse operation: +10 to 0 VDC/0 to 100% <p>* It can be used only on one Terminal "V2" or "C1" alternatively.</p> <p>* Input resistance: 22k ohms</p>
	C1	Current input	<ol style="list-style-type: none"> Frequency is set according to the analog input current supplied from an external circuit. <ul style="list-style-type: none"> - 4 to 20mA DC / 0 to 100% - Reverse operation: 20 to 4mA DC / 0 to 100% The feedback signal for PID control is input. PTC thermistor input  <p>* Use only one Terminal - V2 or C1 exclusively</p> <p>* Input resistance: 250 ohms</p> <p>* PTC switch is off when PTC function is not used</p>
	11	Analog input common	Common terminal for analog input signals

Digital input	FWD	Forward operation / Stop command	Used for forward operation (when FWD-CM is on) or deceleration and stop (when FWD-CM is opened)																							
	REV	Reverse operation / Stop command	Used for reverse operation (when REV-CM is on) or deceleration and stop (when REV-CM is opened)																							
	X1	Digital input 1	<p>The coast-to-stop command, external alarm, alarm reset, multi-step frequency selection, and other functions (from an external circuit) can be assigned to Terminals X1 to X9. For details, see "Setting the Terminal Functions E01 to E09" in Section 5.2 Function Explanation.</p> <p><Specifications of digital input circuit></p> <table border="1"> <thead> <tr> <th>Item</th> <th></th> <th>min.</th> <th>typ.</th> <th>max.</th> </tr> </thead> <tbody> <tr> <td rowspan="2">Operating voltage</td> <td>ON</td> <td>0V</td> <td>-</td> <td>2V</td> </tr> <tr> <td>OFF</td> <td>22V</td> <td>24V</td> <td>27V</td> </tr> <tr> <td rowspan="2">Maximum load current</td> <td>ON</td> <td>-</td> <td>3.2mA</td> <td>4.5 mA</td> </tr> <tr> <td>OFF</td> <td>-</td> <td>-</td> <td>0.5 mA</td> </tr> </tbody> </table>	Item		min.	typ.	max.	Operating voltage	ON	0V	-	2V	OFF	22V	24V	27V	Maximum load current	ON	-	3.2mA	4.5 mA	OFF	-	-	0.5 mA
	Item			min.	typ.	max.																				
	Operating voltage	ON		0V	-	2V																				
		OFF		22V	24V	27V																				
	Maximum load current	ON		-	3.2mA	4.5 mA																				
		OFF		-	-	0.5 mA																				
	X2	Digital input 2																								
	X3	Digital input 3																								
	X4	Digital input 4																								
	X5	Digital input 5																								
	X6	Digital input 6																								
X7	Digital input 7																									
X8	Digital input 8																									
X9	Digital input 9																									
P24	Control unit power supply	+24 VDC power supply for control input. Maximum output current 100mA																								
PLC	PLC signal power	Used to connect a power supply for PLC output signals; rated voltage = 24 VDC (22 to 27) at sink logic operation.																								
CM	Digital input common	Common terminal for digital input signals and P24																								
Analog output	FMA (11: common terminal)	Analog monitor	<p>Outputs monitor signal using analog DC voltage 0 to +10 VDC. The signal indicates one of the following:</p> <ul style="list-style-type: none"> - Output frequency (before slip compensation) - Load factor - Output frequency (after slip compensation) - Power consumption - Output current - PID feedback value - Output voltage - PG feedback value - Output torque - DC link circuit voltage <p>* Connectable impedance: minimum 5k ohms</p>																							
Pulse output	FMP (CM: common terminal)	Frequency monitor (pulse waveform output)	<p>Outputs a monitor signal using the pulse waveform. This signal has the same function as the FMA signal.</p>																							

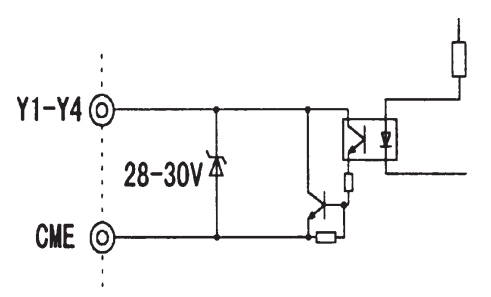
Transistor	Y1	Transistor output 1	A running signal, frequency equivalence signal, overload relay warning output signal, and other signals from the drive are output (as transistor output) to arbitrary ports. For details, see "Setting the Terminal Functions E20 to E23" in Section 5.2 Function Explanation. * <Specifications of transistor output circuit>																								
	Y2	Transistor output 2																									
	Y3	Transistor output 3																									
	Y4	Transistor output 4																									
				<table border="1"> <thead> <tr> <th>Item</th> <th></th> <th>min.</th> <th>typ.</th> <th>max.</th> </tr> </thead> <tbody> <tr> <td rowspan="2">Operating voltage</td> <td>ON</td> <td>-</td> <td>1V</td> <td>2V</td> </tr> <tr> <td>OFF</td> <td>-</td> <td>24V</td> <td>27V</td> </tr> <tr> <td>Maximum load current</td> <td>ON</td> <td>-</td> <td>-</td> <td>50 mA</td> </tr> <tr> <td>Leakage current</td> <td>OFF</td> <td>-</td> <td>-</td> <td>0.1 mA</td> </tr> </tbody> </table> 	Item		min.	typ.	max.	Operating voltage	ON	-	1V	2V	OFF	-	24V	27V	Maximum load current	ON	-	-	50 mA	Leakage current	OFF	-	-
Item		min.	typ.	max.																							
Operating voltage	ON	-	1V	2V																							
	OFF	-	24V	27V																							
Maximum load current	ON	-	-	50 mA																							
Leakage current	OFF	-	-	0.1 mA																							
	CME	Transistor output common	Common terminal for transistor output signals. This terminal is insulated from Terminals (CM) and [11].																								
Relay output	30A,30B,30C	Alarm outputs for any fault.	If the drive is stopped by an alarm (protective function), the alarm signal is output from the relay contact output terminal (1SPDT). Contact rating: 250 VAC, 0.3A, cos ϕ = 0.3, 48 VDC, 0.5A for CE Marking An excitation mode (excitation at alarm occurrence or at normal operation) can be selected.																								
Y5A,Y5C		Multi-purpose signal	These signals can be output similar to the Y1 to Y4 signals above. The contact rating is the same as that of the alarm output above.																								
Communication	DX+, DX-	RTU communication	Input / output signal terminals for RTU communication input / output Up to 31 drives can be connected using the daisy chain method.																								
	SD	Communication cable shield connection terminal	Terminal for connecting the cable shield. The terminal is electrically floating.-																								

(1) Analog input terminals (13, 12, C1, and 11)

1. These terminals receive low level analog signals that may be affected by external noise. The cables must be as short as possible (20 meters or less), must be shielded, and the shields must be grounded. If the cables are affected by external induction noise, the shielding effect may be improved by connecting the shield to Terminal [11].
2. If contacts must be connected to these circuits, twin (bifurcated) contacts for handling low level signals must be used. A contact must not be connected to Terminal [11].
3. If an external analog signal output device is connected to these terminals, it may malfunction as a result of drive noise. To prevent malfunction, connect a ferrite core or capacitor to the external analog signal output device.

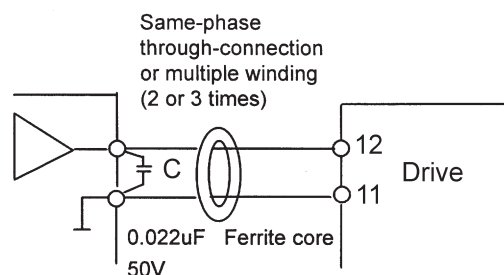
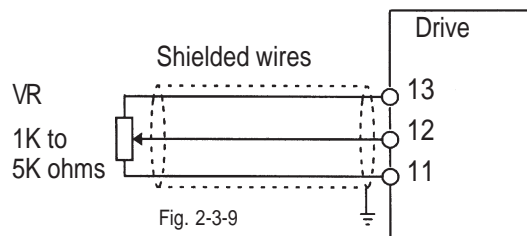

Fig. 2-3-10 Examples of Noise Prevention

(2) Digital input terminals (FWD, REV, X1 to X9, PLC, and CM)

1. Digital input Terminals (e.g., FWD, REV, X1 to X9) are generally turned on or off by connecting or disconnecting the line to or from the CM Terminal.

If digital input terminals are turned on or off by switching the PLC's open collector output using an external power supply, a resulting bypass circuit may cause the drive to malfunction. To prevent a malfunction, connect the PLC terminal as shown in Fig. 2-3-11.

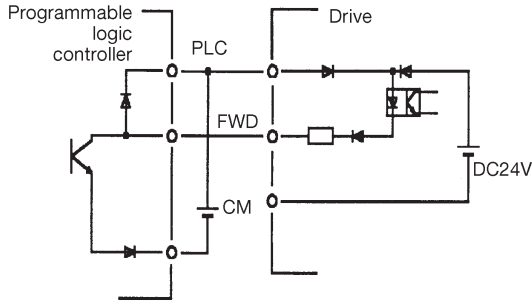

Fig. 2-3-11 Prevention of Bypass Current by External Power

2. When using a contact input, a high-quality relay with reliable contacts must be used.

(3) Transistor output terminals (Y1 to Y4, CME)

1. These terminals have a circuit configuration as shown in Table 2-3-3, "Transistor Output." Confirm the polarity of the external power supply.
2. To connect a control relay, connect a surge absorbing diode to both ends of its exciting coil.

(4) Sink or Source Logic Selection.

1. Set SWI for Sink or Source Connection to the PLC. The factory default setting is Sink, and this instruction manual explains Sink logic function only.
2. When you need to connect source type logic, refer to Basic Connection Diagram on pages 2-6 and 2-7, and Technical Information Manual. (Sink Logic is commonly used in the USA and Source Logic is commonly used in Europe.)

(5) Others

1. To prevent a malfunction as a result of noise, control terminal cables must be placed as far as possible from the main circuit cables.
2. The control cables inside the drive must be secured to prevent direct contact with the main circuit (e.g., main circuit terminal block).

WARNING

Control lines generally do not have enhanced insulation. If the insulation of a control line is damaged, the control signals may be exposed to high voltage in the main circuit. The Low Voltage Directive in Europe also restricts the exposure to high voltage. Electric shock may occur.

CAUTION

The drive, motor, and cables generate noise. Check that the ambient sensors and devices do not malfunction. Accidents may occur.

(6) Wiring of control circuit (drives of 40HP or more)

1. Pull out the control circuit wiring along the left panel as shown in Fig. 2-3-12.
2. Secure the cable to cable binding Hole A (on the left wall of the main circuit terminal block) using a cable-tie (e.g., Insulock). The cable-tie must not exceed 0.14" (3.5mm) in width and 0.06" (1.5mm) in thickness.
3. When the optional PC board is mounted, the signal lines must be secured to cable binding Hole B.

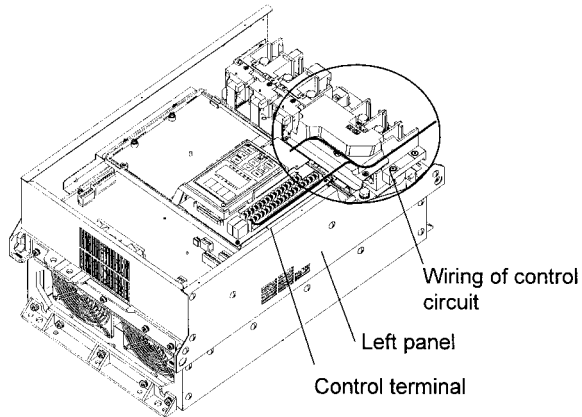

Fig. 2-3-12 The Control Wiring Route

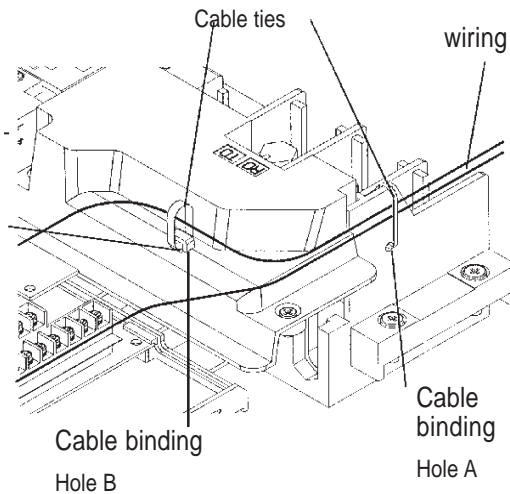
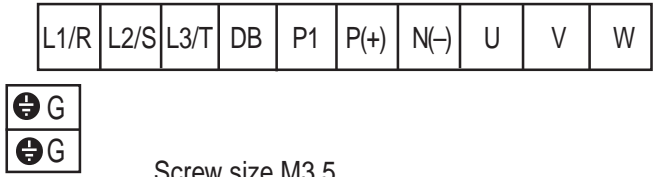
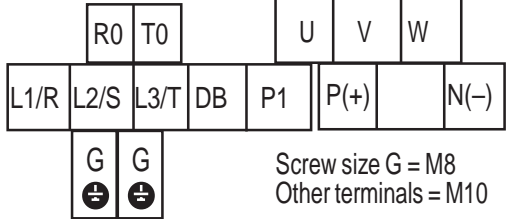
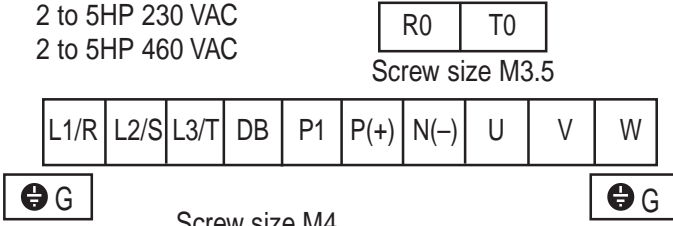
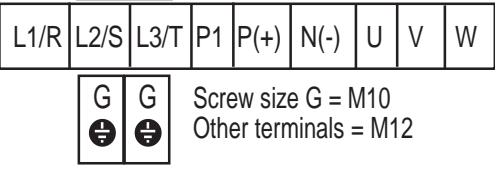
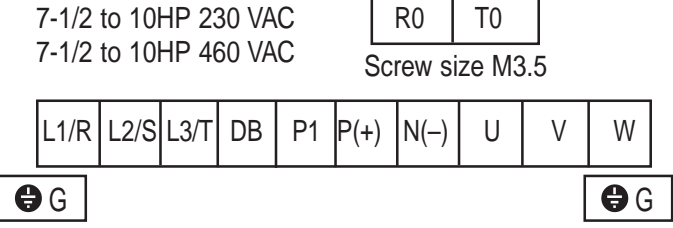
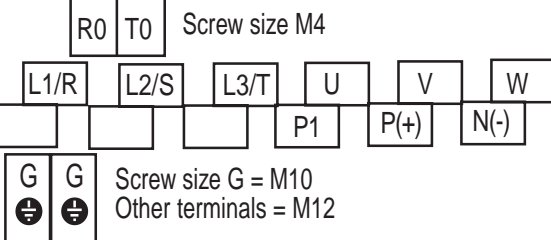
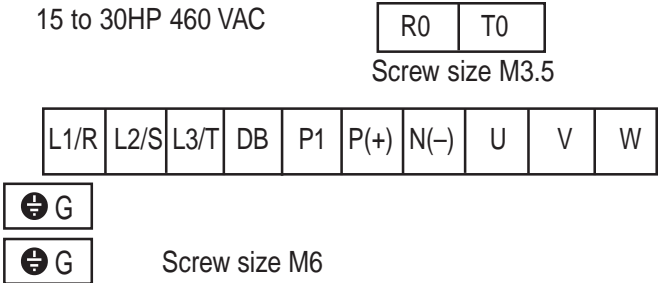
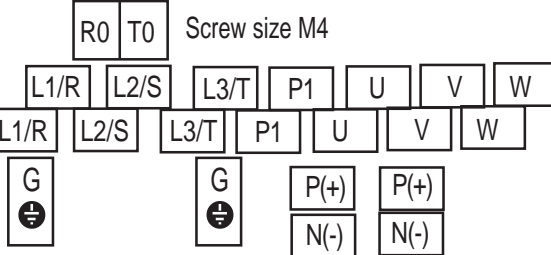
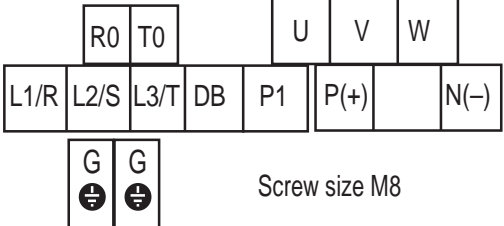
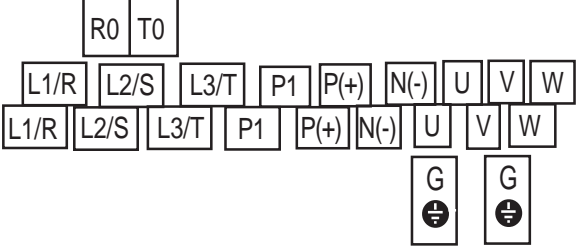

Fig. 2-3-13 Securing Positions for Drive Control Circuit Wiring (40HP or more)

2.3.4 Terminal Configuration

(1) Main circuit terminals

<p>1/4 to 1HP 230 VAC 1/2 to 1HP 460 VAC</p>  <p>Screw size M3.5</p>	<p>50 To 75HP 230 VAC 100 to 150HP 460 VAC</p>  <p>Screw size G = M8 Other terminals = M10</p>
<p>2 to 5HP 230 VAC 2 to 5HP 460 VAC</p>  <p>Screw size M4</p>	<p>100HP 230 VAC</p>  <p>Screw size G = M10 Other terminals = M12</p>
<p>7-1/2 to 10HP 230 VAC 7-1/2 to 10HP 460 VAC</p>  <p>Screw size M5</p>	<p>125HP 230 VAC 200 to 350HP 460 VAC</p>  <p>Screw size G = M10 Other terminals = M12</p>
<p>15 to 30HP 230 VAC 15 to 30HP 460 VAC</p>  <p>Screw size M6</p>	<p>400, 450HP 460 VAC</p>  <p>Screw size G = M10 Other terminals = M12</p>
<p>40HP 230 VAC 40 to 75HP 460 VAC Screw size M4</p>  <p>Screw size M8</p>	<p>500, 600HP 460 VAC</p>  <p>Screw size R0, T0 = M4 G = M10 Other terminals = M12</p>

2.3.6 DC Link Reactor

Dimensions in inches

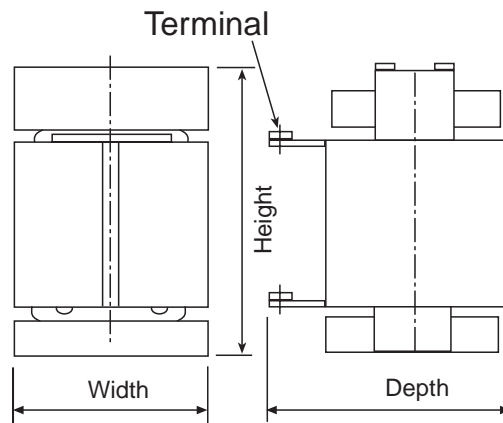

HP	Model No.	Width	Depth	Height	Weight	Loss [W]
230V						
100	DCR2-75B	7.87	10.63	7.09	37	55
125	DCR2-90B	7.09	11.02	8.46	37	57
460V						
100	DCR4-75B	7.48	10.63	6.89	35	58
125	DCR4-90B	7.48	11.02	7.87	44	64
150	DCR4-110B	7.48	11.02	7.87	46	73
200	DCR4-132B	7.87	11.02	8.07	55	84
250	DCR4-160B	8.27	12.6	8.07	68	90
300	DCR4-200B	8.27	12.99	9.06	75	126
350	DCR4-220B	8.66	13.78	9.06	81	131
400	DCR4-280B	8.66	14.57	9.65	95	133
450	DCR4-315B	9.84	12.01	8.78	88	150
500	DCR4-355B	9.84	12.99	8.78	99	205
600	DCR4-400B	9.84	13.78	9.17	106	215

Notes:

- Drives rated 100HP and above are furnished with a DC link reactor. This reactor must be installed between terminal P1 and P+ prior to commissioning of the drive.
- The weight of the DC Link Reactor is not included with that of the drive.
- DC Link Reactor is provided as open type and is separately mounted. Enclosure to be provided by others.

Notes

3. Operation

3.1 Inspection and Preparation Before Operation

Check the following before operation:

1. Check that the connections are correct.
In particular, check that the power supply is not connected to any of the U, V, or W output terminals and that the ground terminal is securely grounded.
2. Check for short circuits and ground faults between the terminals and sections under power.
3. Check for loose terminals, connectors, or screws.
4. Check that the motor is disconnected from the mechanical equipment.
5. Turn off switches before turning on power to ensure that the drive will not start or operate abnormally at power-on.
6. Check the following after power-on:
 - a. No alarm message is displayed on the keypad panel (see Figure 3-1-2).
 - b. The fan inside the drive is rotating. (For drives rated 2HP or higher.)

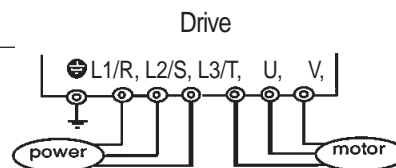

Fig.3-1-1 Drive connection

WARNING

Be sure to have the drive cover in place before turning on the power. Never remove the cover while power is applied to the drive. To ensure safety, do not operate switches with wet hands. Electric shock may occur.

3.2 Operation Method

There are various methods of operation. Select a method of operation according to the operating requirements and specifications; refer to Section 4-2 Operating the Keypad Panel, and Chapter 5 Function Selection. Table 3-2-1 lists general methods of operation.

3.3 Trial Run

Once inspection is completed (see Section 3-1), proceed with a trial run. The motor is initially disconnected and the drive is operated (factory setting) using the keypad panel.

1. Turn power on and confirm that the LED monitor display 0.00 Hz is blinking.
2. Set the frequency to about 5 Hz using key.
3. To start the run, press **FWD** key (for forward rotation) or **REV** key (for reverse rotation). To stop, press **STOP** key. Verify that the frequency increases from zero to the set point.

Connect the motor and repeat steps 1-3

4. Check the following items:
 - a. Is the direction of rotation correct?
 - b. Is the rotation smooth (no buzzing or abnormal vibration)?
 - c. Are acceleration and deceleration smooth?
5. If no abnormality is detected, increase the frequency and check the above items again. If the results of the trial run are normal, start a formal run.



Fig.3-1-2 Display on keypad panel at power-on

Operation Command	Frequency Setting	Operation Command
Operation using keypad panel	Keys on keypad panel 	FWD REV STOP
Operation using external terminal signals	 Frequency Setting POT(VR), analog voltage, analog current	Input from Terminals FWD-CM and REV-CM

Notes: If an error is detected in the drive or motor operation, immediately stop and attempt to determine the cause of error by referring to Chapter 7 Troubleshooting.

Since voltage is still present at the main circuit Terminals (L1/R, L2/S, L3/T) and auxiliary control power Terminals (R0, T0), even when the output from the drive is terminated, do not touch the terminals. The smoothing capacitor in the drive is charged after the power is turned off and it is not discharged immediately. Before touching an electric circuit, confirm that the charge lamp is off or use a multimeter to check that the voltage has decreased below 25 VDC at the DC (P-N) Terminals.

Notes

4. Keypad Panel

The keypad panel has various functions for specifying operations such as frequency setting, run/stop command, confirming and changing function data, confirming status, and copying function code settings.

Review the use of each function before attempting to operate the drive from the keypad panel.

The keypad panel can also be removed or inserted during drive operation. However, if the keypad panel is removed during keypad panel operation (e.g., run/stop, frequency setting), the drive stops and outputs an alarm.

4.1 Appearance of Keypad Panel



Control keys (valid during keypad panel operation):

Used for drive run and stop

FWD Forward operation command

REV Reverse operation command

STOP Stop command

Operation keys:

Used for switching screens, data change, frequency setting, etc.

Operation Keys

Primary Function

PRG	Used to switch the current screen to the menu screen or switch to the initial screen in operation / trip mode.
FUNC DATA	Used to switch the LED monitor or to determine the entered frequency, function code, or data.
▲ ▼	Used to change data, move the cursor up or down, or scroll the screen.
SHIFT >>	Used to move the cursor horizontally at data change. When this key is pressed with the Up or Down key, the cursor moves to the next function block.
RESET	Used to cancel current input data and switch the displayed screen. If an alarm occurs, this key is used to reset the trip status (valid only when the initial alarm mode screen is displayed).
STOP + ▲	Used to switch normal operation mode to jogging operation mode or vice versa. The selected mode is displayed on the LCD monitor.
STOP + RESET	Switches operation mode (from keypad panel operation mode to terminal block operation mode or reverse). When these keys are operated, Function F01 data is also switched from 0 to 3 or from 1-4 to 0. The selected mode is displayed on the LCD indicator.

LED monitor

4-digit display. Used to display data such as setting frequency, output frequency and alarm code.

Auxiliary Information Related to LED Monitor

Indicates selected units or multiple of the data shown on the LED monitor and is displayed on the top line of the LCD monitor. The **■** symbol indicates selected units or multiple number. The symbol **▲** indicates that there is an upper screen not currently displayed.

LCD Monitor:

Used to display various items of information such as operation status and function data. An operating guide message is scrolled and displayed at the bottom of the LCD monitor. This LCD monitor has a backlight feature which turns on when the control power is applied or any keypad key is pressed, and stays on approximately 5 minutes after the last key stroke.

Status Indicators on LCD Monitor:

Displays current operating status:

FWD: Forward operation REV: Reverse operation

STOP: Stop

Displays the selected operating mode:

REM: terminal block

LOC: keypad panel

COMM: communication terminal

JOG: jogging mode

The symbol **▼** indicates that there is a lower screen not currently displayed.

RUN LED (valid during operation from keypad panel):

Indicates that an operation command was input by pressing the FWD or REV key.

4.2 Operation From the Keypad Panel (LCD Screen, Level Structure)

4.2.1 Normal Operation

The keypad panel operating system (screen transition, level structure) is structured as follows:

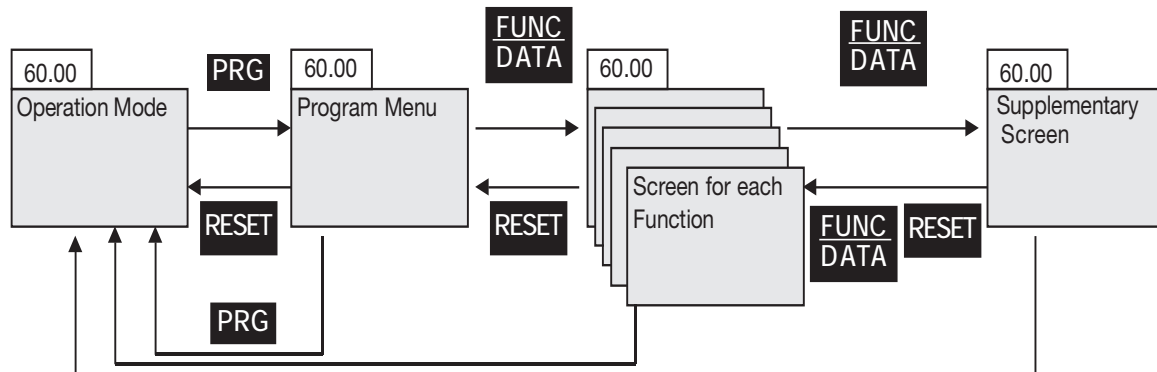

4.2.2 Alarm Modes

If an alarm is activated, operation is changed from normal keypad panel operation to an alarm mode operation. The alarm mode screen appears and alarm information is displayed.

The program menu, function screens, and supplementary screens remain unchanged as during normal operation, though the switching method from program menu to alarm mode is limited to PRG.

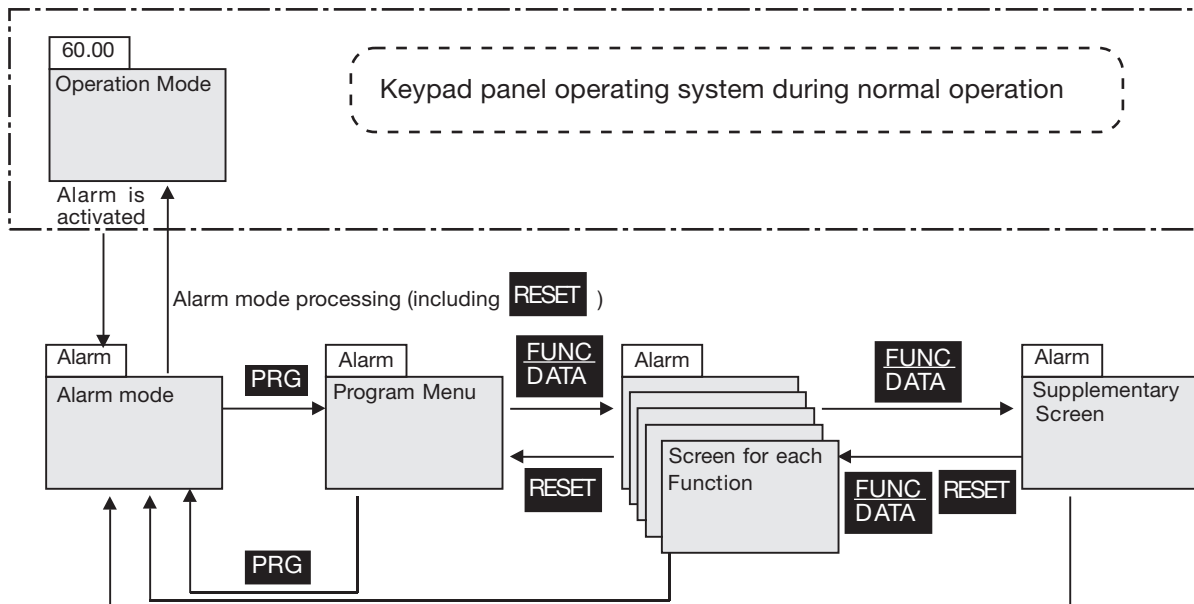





Table 4.2.1 Overview of Contents Displayed for each Level

No.	Level name	Content																														
1	Operation Mode	This screen is for normal operation. Frequency setting from the keypad panel and LED monitor switching are possible only when this screen is displayed.																														
2	Program Menu	Each function of the keypad panel is displayed in menu form and can be selected. By selecting the desired function from the list and pressing  the corresponding function screen is displayed. The following functions are available as keypad panel functions (menus).																														
		<table border="1"> <thead> <tr> <th>No.</th> <th>Menu Name</th> <th>Purpose</th> </tr> </thead> <tbody> <tr> <td>1</td> <td>DATA SET</td> <td>The code and name of the function are displayed. Selecting a function displays a data setting screen for checking or modifying data.</td> </tr> <tr> <td>2</td> <td>DATA CHECK</td> <td>The code and name of the function are displayed. Select a function to display a screen for checking data. Modifying data is possible as described above by going to the data setting screen.</td> </tr> <tr> <td>3</td> <td>OPR</td> <td>Can check various data on the operating status.</td> </tr> <tr> <td>4</td> <td>I/O CHECK</td> <td>Can check the status of analog and digital input/outputs for the inverter and options as an I/O checker.</td> </tr> <tr> <td>5</td> <td>MAINTENANCE</td> <td>Can check inverter status, life expectancy, communication error status, and ROM version information as maintenance information.</td> </tr> <tr> <td>6</td> <td>LOAD FCTR</td> <td>Can measure maximum and average current and average breaking force in load rate measurement.</td> </tr> <tr> <td>7</td> <td>ALM INF</td> <td>Can check the operating status and input/output status at the latest alarm occurrence.</td> </tr> <tr> <td>8</td> <td>ALM CAUSE</td> <td>Can check the latest alarm or simultaneously occurring alarms and alarm history. Selecting the alarm and pressing  displays alarm contents for troubleshooting.</td> </tr> <tr> <td>9</td> <td>DATA COPY</td> <td>Places the function of one inverter in memory for copying to another drive.</td> </tr> </tbody> </table>	No.	Menu Name	Purpose	1	DATA SET	The code and name of the function are displayed. Selecting a function displays a data setting screen for checking or modifying data.	2	DATA CHECK	The code and name of the function are displayed. Select a function to display a screen for checking data. Modifying data is possible as described above by going to the data setting screen.	3	OPR	Can check various data on the operating status.	4	I/O CHECK	Can check the status of analog and digital input/outputs for the inverter and options as an I/O checker.	5	MAINTENANCE	Can check inverter status, life expectancy, communication error status, and ROM version information as maintenance information.	6	LOAD FCTR	Can measure maximum and average current and average breaking force in load rate measurement.	7	ALM INF	Can check the operating status and input/output status at the latest alarm occurrence.	8	ALM CAUSE	Can check the latest alarm or simultaneously occurring alarms and alarm history. Selecting the alarm and pressing  displays alarm contents for troubleshooting.	9	DATA COPY	Places the function of one inverter in memory for copying to another drive.
		No.	Menu Name	Purpose																												
		1	DATA SET	The code and name of the function are displayed. Selecting a function displays a data setting screen for checking or modifying data.																												
		2	DATA CHECK	The code and name of the function are displayed. Select a function to display a screen for checking data. Modifying data is possible as described above by going to the data setting screen.																												
		3	OPR	Can check various data on the operating status.																												
		4	I/O CHECK	Can check the status of analog and digital input/outputs for the inverter and options as an I/O checker.																												
		5	MAINTENANCE	Can check inverter status, life expectancy, communication error status, and ROM version information as maintenance information.																												
		6	LOAD FCTR	Can measure maximum and average current and average breaking force in load rate measurement.																												
		7	ALM INF	Can check the operating status and input/output status at the latest alarm occurrence.																												
8	ALM CAUSE	Can check the latest alarm or simultaneously occurring alarms and alarm history. Selecting the alarm and pressing  displays alarm contents for troubleshooting.																														
9	DATA COPY	Places the function of one inverter in memory for copying to another drive.																														
3	Screen for each Function	The function screen selected on the program menu appears, hence completing the function.																														
4	Supplementary individual	Functions not completed (e.g., modifying function data, displaying alarm factors) onScreen function screens are displayed on the supplementary screen.																														

4.3 Entering Data on the Keypad Panel

4.3.1 Operation Mode

The screen for normal drive operation includes a screen for displaying drive operating status and a screen for graphically displaying the status in the form of a bar graph. The operator can switch between both screens by using the Function (E45).

1) Operating Status (E45=0)

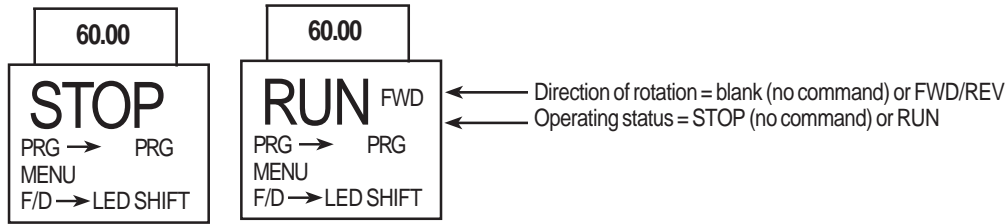

2) Bar Graph (E45=1)

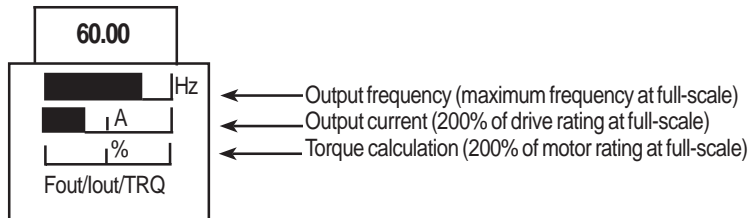

4.3.2 Setting Digital Frequency

On the operation mode screen, press **▲** or **▼** to display the set frequency on the LED. Data is increased or decreased in the smallest possible unit, depending on which key is pressed. The adjustments in data will occur rapidly if the operator holds down **▲** or **▼**. To select a digit, use **SHIFT** and then data can be set directly. To save the frequency settings press **FUNC DATA**.

Press **RESET** and **PRG** to return to the operation mode. If keypad panel settings are not selected, the present frequency setting mode appears on the LCD. When selecting the PID function, the PID command can be set with a process value (refer to technical documentation for details).

1) Digital (keypad panel) settings (F01=0 or C30=0)

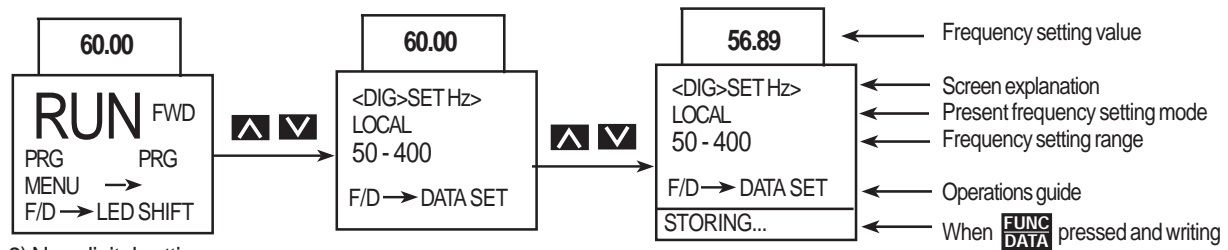

2) Non-digital setting

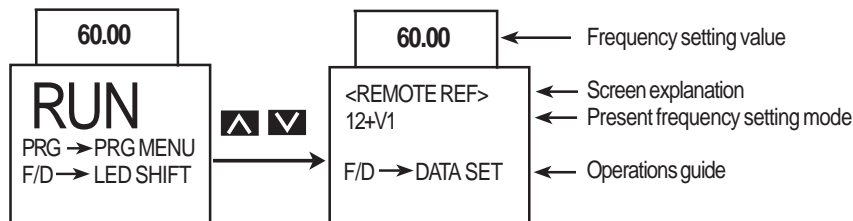

4.3.3 Switching to LED Digital Monitor

During normal operation, press **FUNC DATA** to switch to LED monitor display. When monitored data is switched, the LED monitor contents are displayed. When power is turned on, the monitor contents set by the Function (E43) are displayed on the LED.

E43	When stopping		When running (E44 = 0.1)	Unit	Remarks
	(E44 = 0)	(E44 = 1)			
0	Setting frequency	Output frequency 1 (before slip compensation)	Hz		
1	Setting frequency	Output frequency 2 (after slip compensation)			
2	Setting frequency	Setting frequency			
3	Output current	Output current	A		
4	Output voltage (specified value)	Output voltage (specified value)	V		
5	Synchronous speed setting value	Synchronous speed	r/min.		For 4 digits or more, the last digits are cut, with x10, x100 marked on the indicator.
6	Line speed setting value	Line speed	m/min.		
7	Load rotation speed setting value	Load rotation speed	r/min.		
8	Torque calculation value	Torque calculation value	%		± indication
9	Power consumption	Power consumption	kW		
10	PID setting value	PID setting value	—		
11	PID remote setting value	PID remote setting value	—		Displayed only when PID is effective in PID operation selection.
12	PID feedback value	PID feedback value	—		

4.3.4 Program Menu Screen

The Program Menu screen is shown below. Only four items can be displayed simultaneously. Move the cursor with **▲** or **▼** to select an item, then press **FUNC DATA** to display the next screen.

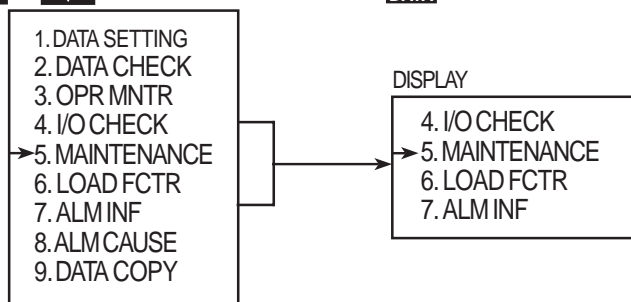

4.3.5 Setting Function Data

On the Program Menu screen, select **1. Data Setting**. The Function Select screen appears with function codes and names on it. Select the desired function.

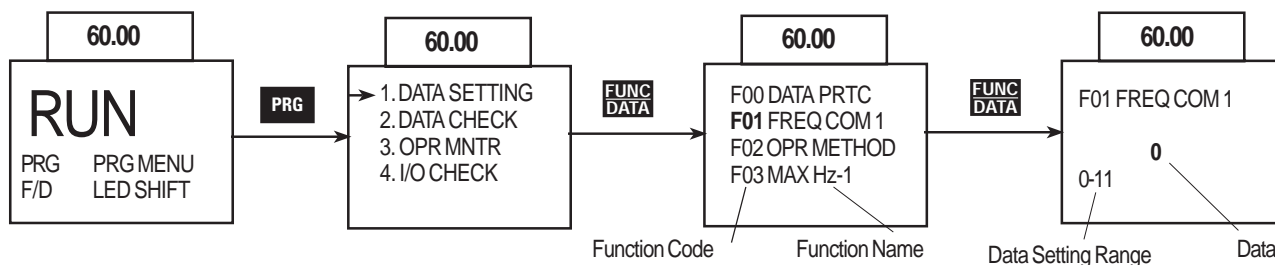

The function code consists of alphanumeric characters with unique letters assigned to each function group.

Table 4-3-1

Function Code	Function	Remarks
F00 - F42	Fundamental Functions	
E01 - E47	Terminal Extension Functions	
C01 - C33	Frequency Control Functions	
P01 - P09	Motor Parameters	
H03 - H39	High Performance Functions	
A01 - A18	Alternative Motor Parameters	
o01 - o29	Optional Functions	Can only be selected with an option connected

To scroll the Function Select screen rapidly, use **>>** + **▲** or **>>** + **▼** to move the screen as a unit sorted alphabetically.

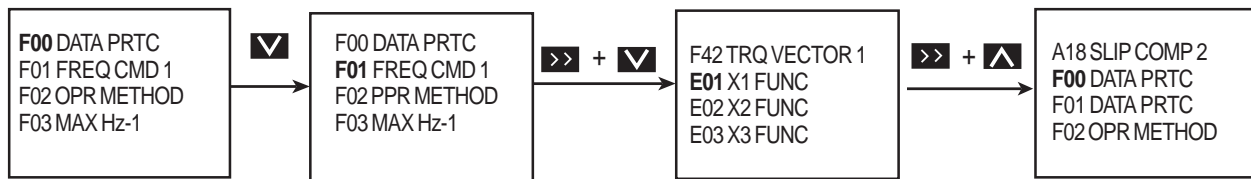

Select the desired function and press **FUNC DATA** to switch to the Data Setting screen.

On the Data Setting screen, the data values on the LCD can be increased or decreased in the smallest possible unit by pressing **▲** or **▼**. Holding down **▲** or **▼** causes the values to increase or decrease more rapidly. Otherwise, select the digit to be modified using **>>** and then set data directly. When data is modified, the value before modification will be displayed at the same time for reference purpose. To save the data, press **FUNC DATA**. Pressing cancels the changes made and returns control to the Function Select screen. The modified data will be effective in drive operation after the data has been saved by **FUNC DATA**. If the data is not saved, there is no change to the drive operation.

When data setting is disabled in the case of “Data protected” or “Data setting invalid during drive running,” make the necessary changes as indicated in Table 4-3-2 below.

Table 4.3.2

Display	Reason for No Modification	Release Method
LINK ACTIVE	Currently writing from RS-485 / RTU option to function is being made	Send a cancel command to function writing from RS-485 RTU. Stops a “write” operation from the link
NO SIGNAL(WE)	The edit enabling command function is selected using a general-purpose input terminal	For Functions E01 to E09, turn data Terminal 19 (edit enabling command selection) ON
DATA PRTCTD	Data protection is selected for Function F00.	Change Function F00 to 0
INV RUNNING	An attempt was made to change a function that cannot be changed during drive operation	Stop drive operation
FWD/REV ON	An attempt was made to change a function that cannot be changed with the FWD/REV command on	Turn FWD/REV command off

4.3.6 Checking Function Data

Select 2. DATA CHECK on the Program Menu screen. The Function Select screen then appears with function codes and names.

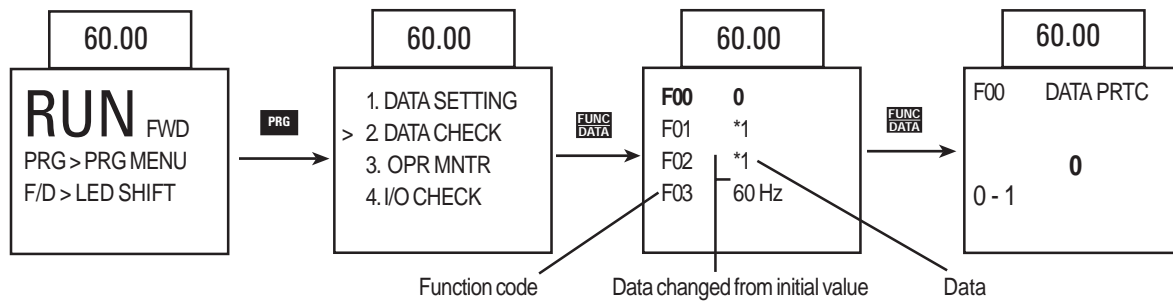

Select the desired function and press FUNC/DATA to check the function data. By pressing FUNC/DATA, the screen switches to the Data Setting screen, where data can be modified.

4.3.7 Monitoring Operating Status

Select 3. OPR MNTR on the Program Menu screen to display the current drive operating status. Use and to switch between the four operation monitor screens.

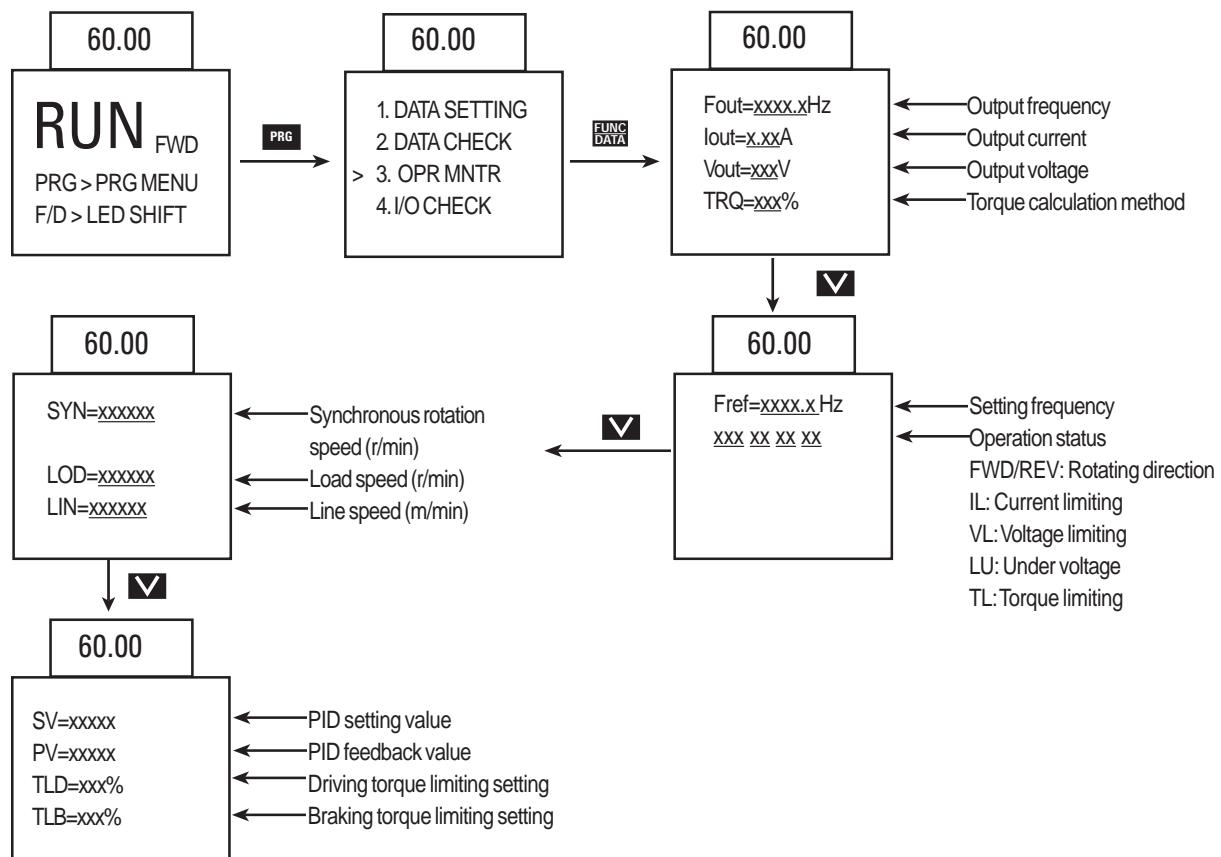



4.3.8 I/O Check

Select 4. I/O on the Program Menu screen. Check to display analog and digital input/output signal status for the drive and options. Use

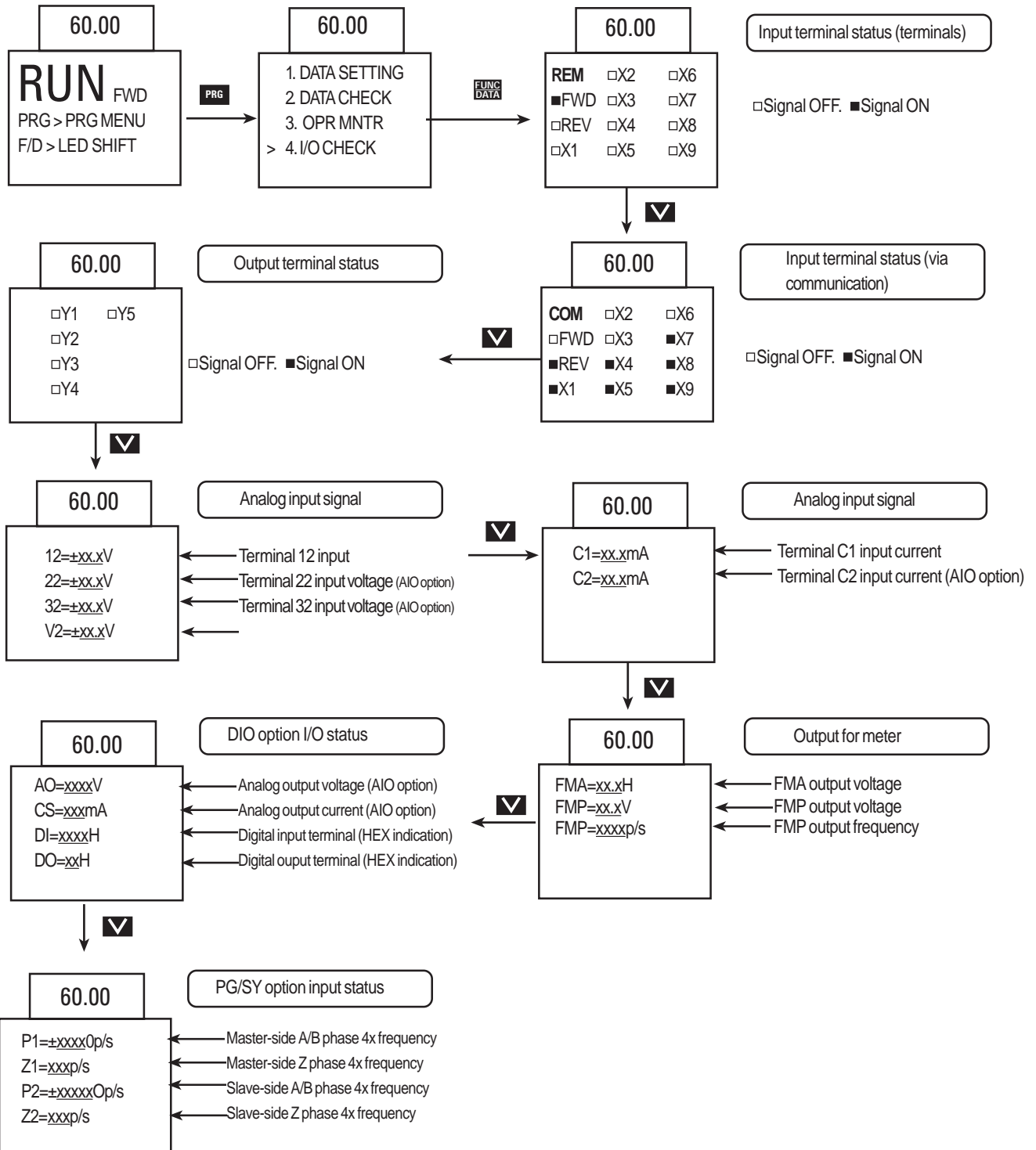
 and  to switch between the seven screens of data.



4.3.9 Maintenance Information

Select 5. on the Program Menu screen. Maintenance to display information necessary for maintenance and inspection. Use  and  to switch between the five screens of data.

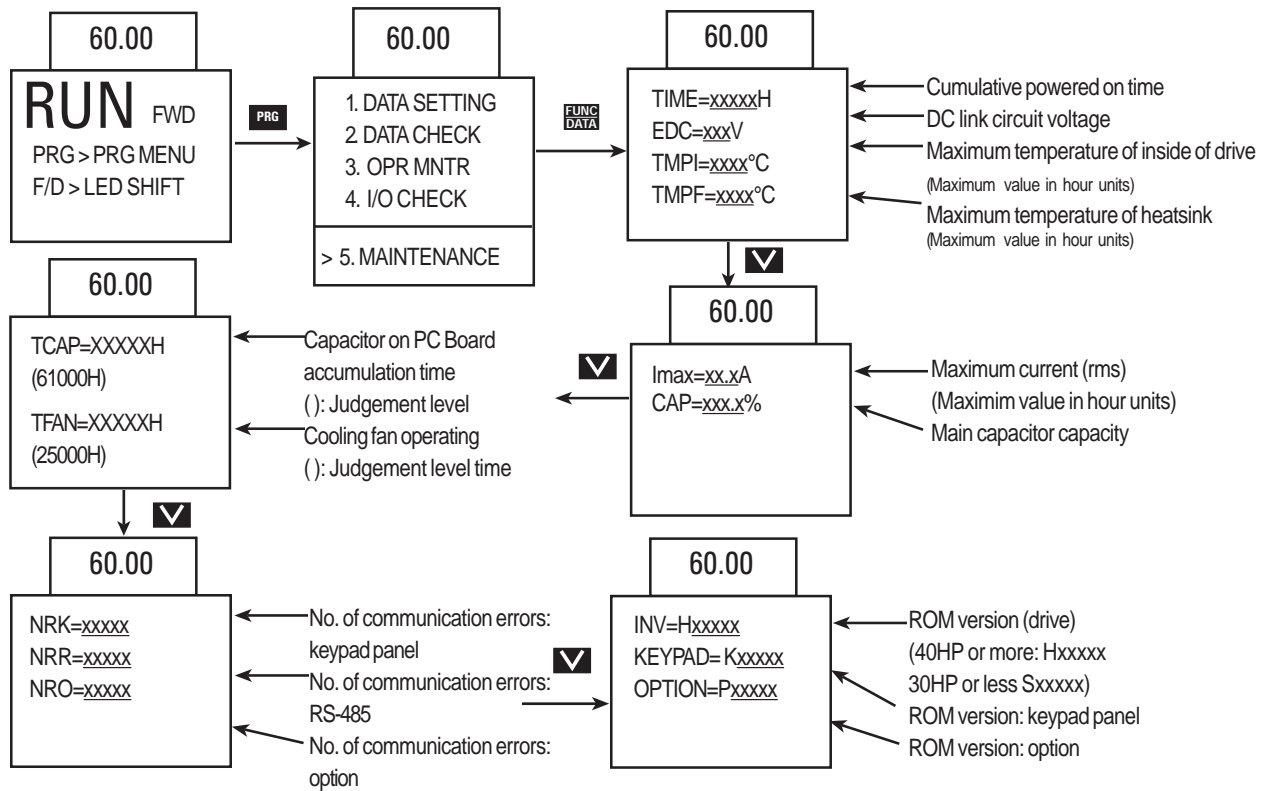

4.3.10 Load Rate Measurement

Select 6. Load Rate Measurement (LOAD FCTR) on the Program Menu screen. The maximum current, average current, and average braking power during the set measuring time are measured and displayed.

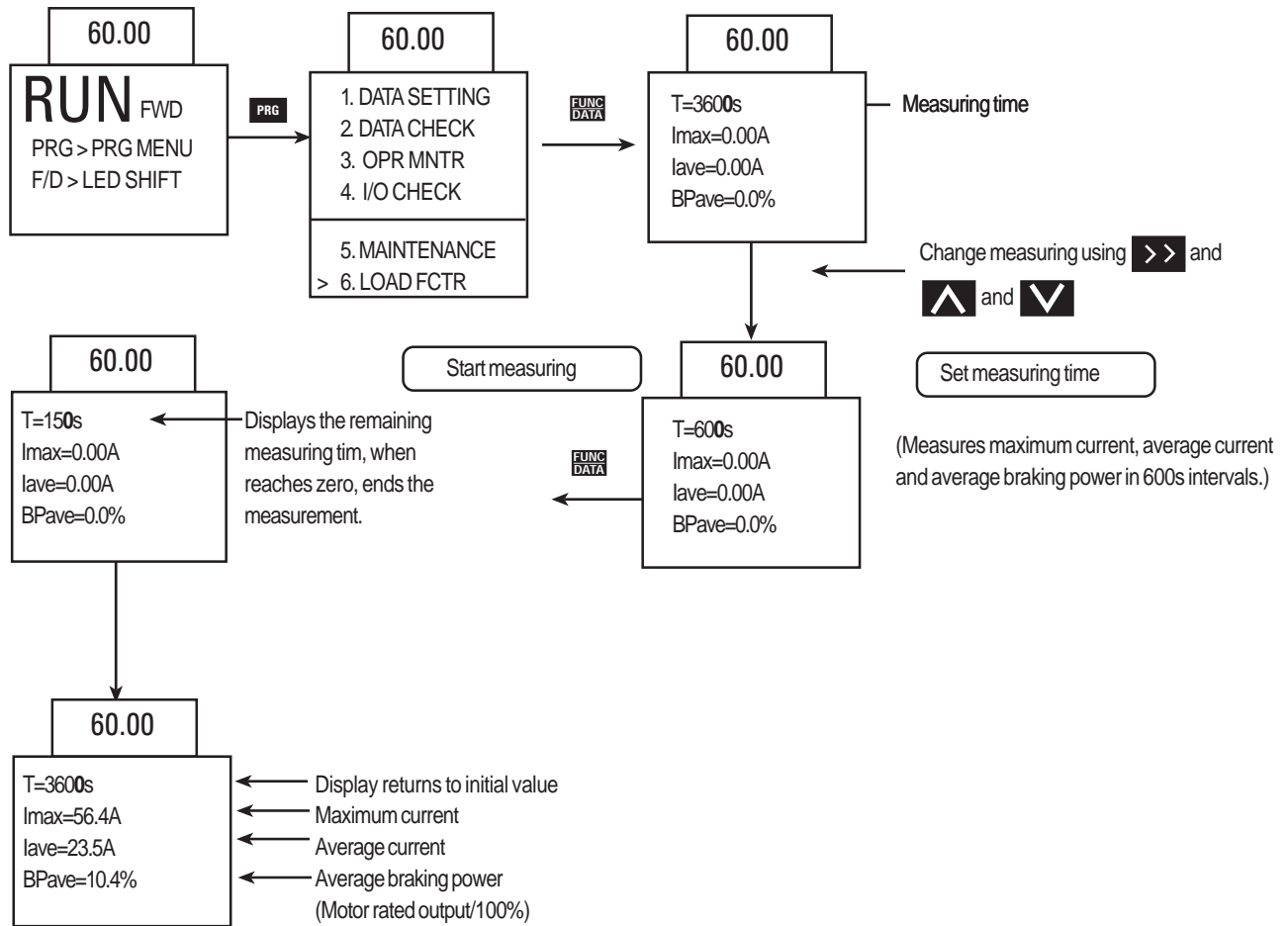

4.3.11 Alarm Information

Select 7. Alarm Information (ALM INF) on the Program Menu screen. A variety of operating data at the time the latest alarm occurred is displayed. Use UP and DOWN to switch between the nine screens of alarm information data.

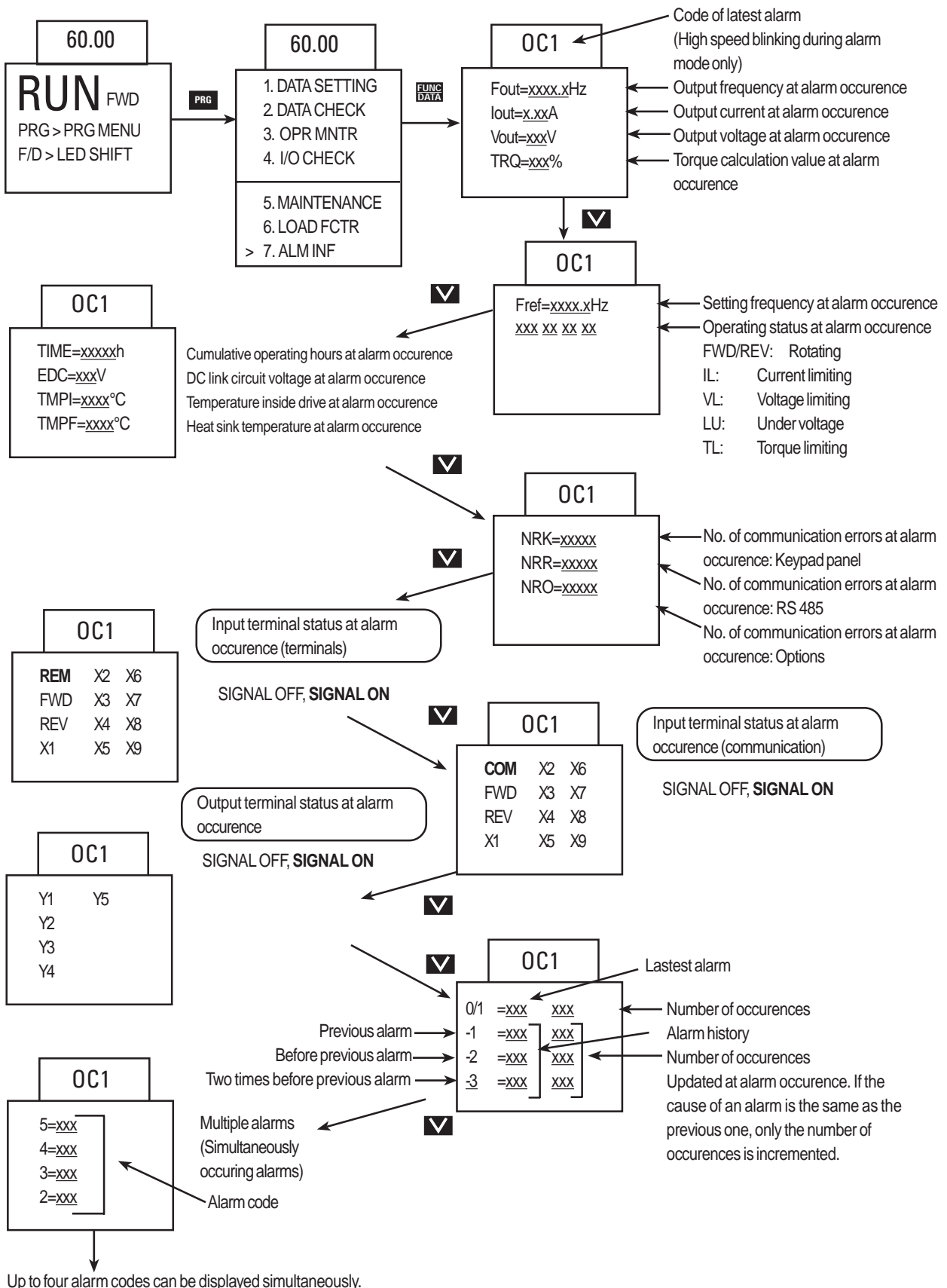

4.3.12 Alarm History and Factors

Select 8. Alarm Cause on the Program Menu screen, to display the alarm history.

Press FUNC/DATA to display troubleshooting information for the alarm selected.

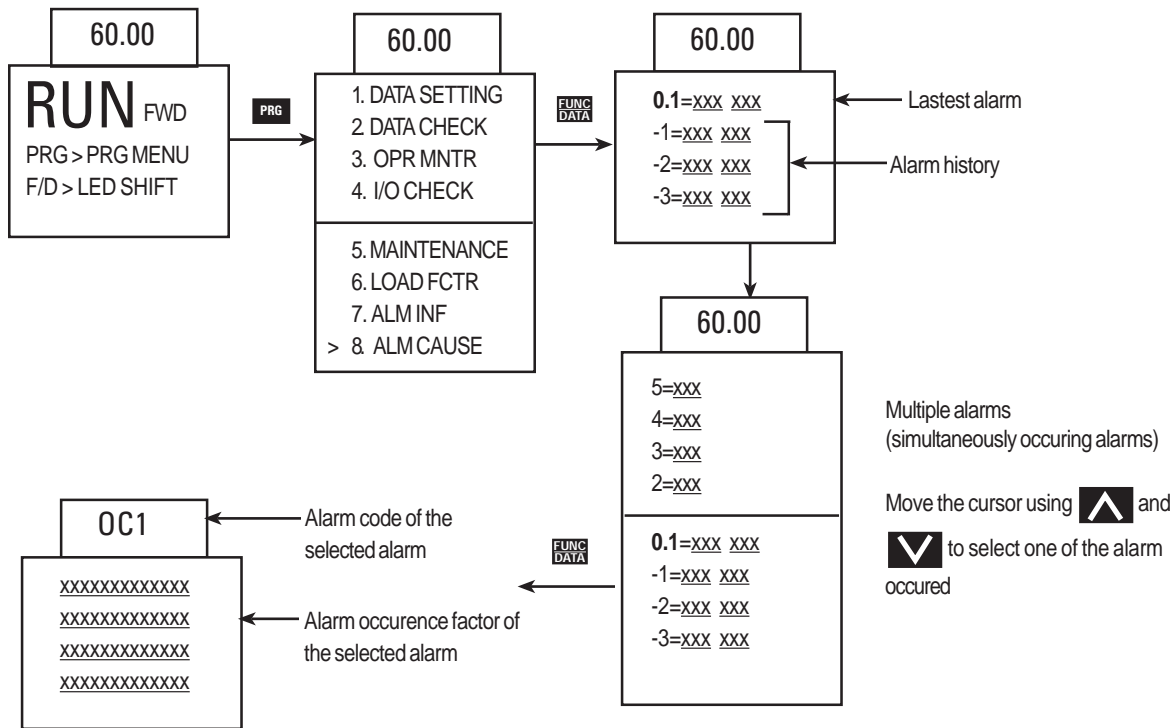

4.3.13 Data Copy

Select 9. Data Copy to display the Data Copy on the Program Menu screen. Read the screen. A copy operation is then performed in the following order: Function data is read from the first drive, the keypad panel is removed and attached to a second drive, the data from the first drive is written to and stored in the second drive.

The “verify” feature also makes it possible to compare and check differences in the data stored in the keypad panel and the data stored in the drive.

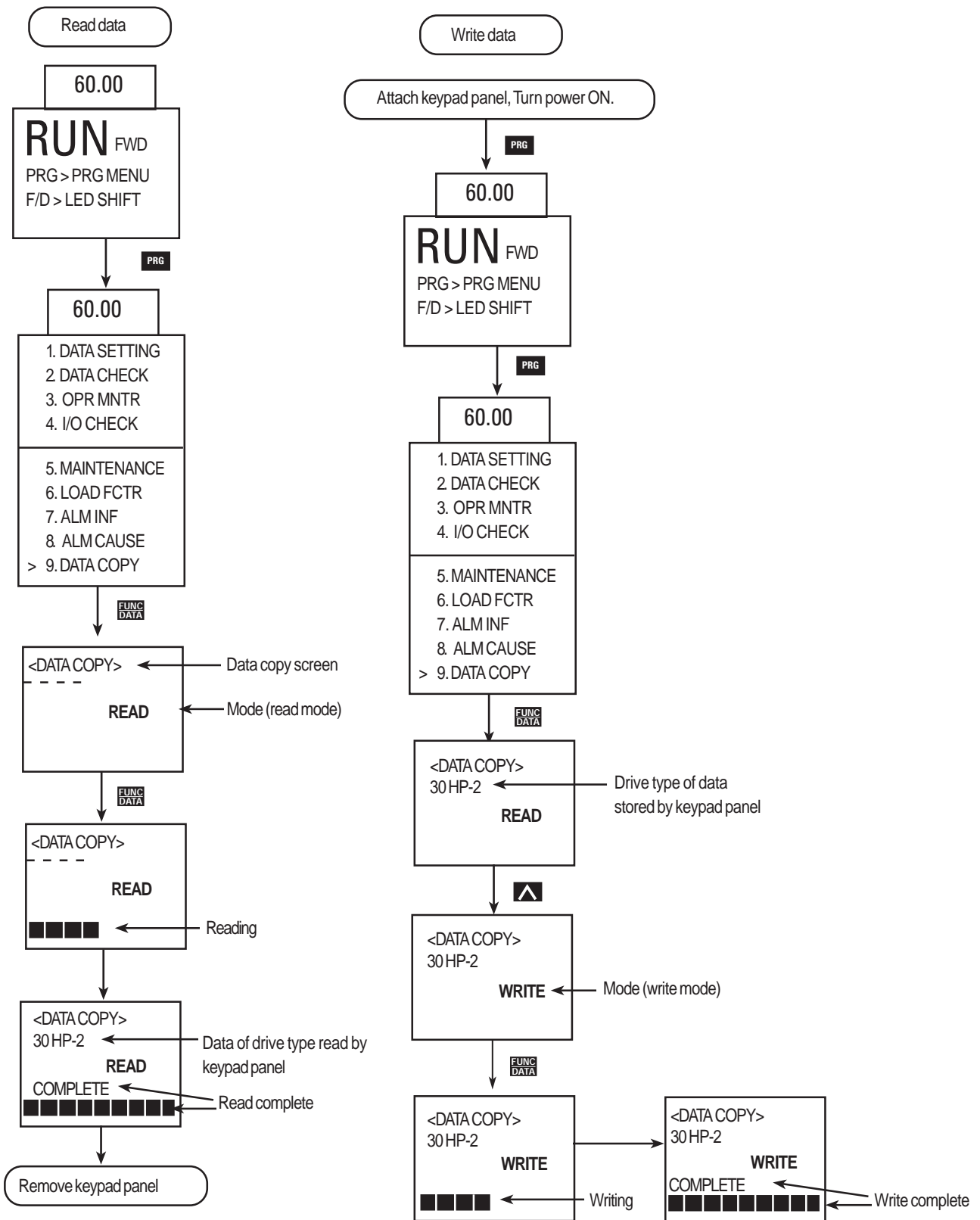

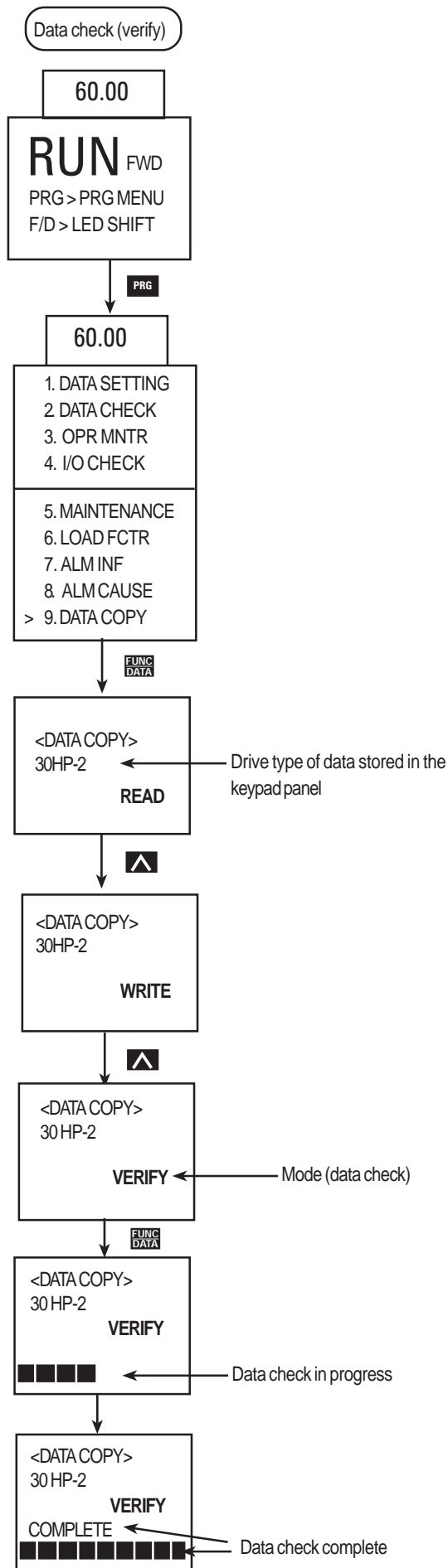

Error processing

1. Change disabled during operation

If a write operation is attempted during a drive operation, or vice versa, the error message below will appear. After stopping the drive and pressing **RESET** retry the write operation.

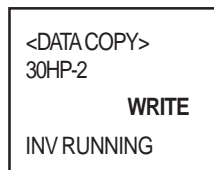

2. Memory error

If a write operation is attempted while data has not been saved (i.e., no data) in the keypad panel data memory during the read mode, or when the drive type of data read by the keypad panel is different from the drive type to which data is to be written, the following error message will appear.

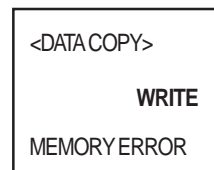

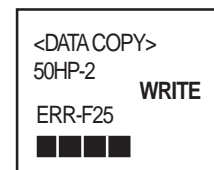

3. Verify error

During a data check (verify) operation, if data stored in the keypad panel differs from data stored in the drive, the following error message is displayed to indicate the function number. The data is suspended. To continue the data check and check for other mismatching data, press **FUNC DATA**. To stop the data check and switch to another operation, press **RESET**.





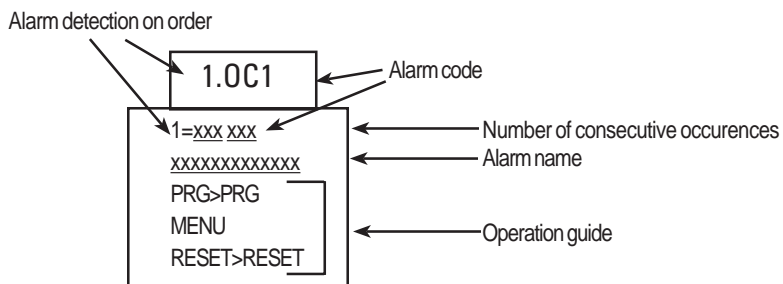

4.3.14 Alarm Mode

If an alarm occurs, the Alarm Screen indicating the alarm contents is displayed. Use  and  to display alarm history and multiple alarms (if more than two alarms occur simultaneously).



Alarm detection order

Operation Method	LED Display	LCD Display	Description
   	5.	5	No. 5 alarm
	4.	4	No. 4 alarm
	3.	3	No. 3 alarm
	2.	2	No. 2 alarm
	1.	1	No. 1 alarm (more than two alarms occurred)
	Blank	0	Latest alarm (only one alarm occurred/alarm released)
	Blank	-1	Previous alarm history
	Blank	-2	Alarm history before previous alarm
	Blank	-3	Alarm history two times before previous alarm

Alarm code: See Table 6-1-1

Notes:

5. Function Selection

5.1 Function Select List

F: Fundamental Functions

Pg.	Func. No.	Name	LCD Display	Setting Range	Unit	Min.	Factory Setting		Data Format	Change During op
							30 HP	40 HP		
5-7	F00	Data protection	F00 DATA PRTC	0, 1	-	-	0		1	N
	F01	Frequency command 1	F01 FREQ CMD 1	0 to 11	-	-	0		1	N
	F02	Operation method	F02 OPR METHOD	0 to 4	-	-	0		1	N
5-10	F03	Maximum frequency 1	F03 MAX Hz-1	50 to 400Hz	Hz	1	60		1	N
	F04	Base frequency 1	F04 BASE Hz-1	25 to 400Hz	Hz	1	60		1	N
	F05	Rated voltage 1 (at Base frequency 1)	F05 RATED V-1	0V: (Output voltage proportional to source voltage) 230V class: 80 to 240V 460V class: 320 to 480V	V	1	230: (230V class) 460: (460V class)		1	N
	F06	Maximum voltage 1 (at Maximum frequency 1)	F06 MAX V-1	230V class: 80 to 240V 460V class: 320 to 480V	V	1	230: (230V class) 460: (460V class)		1	N
	F07	Acceleration time 1	F07 ACC TIME1	0.01 to 3600 s	s	0.01	6.0	20.0	12	Y
	F08	Deceleration time 1	F08 DEC TIME1							
5-11	F09	Torque boost 1	F09 TRQ BOOST1	0.0, 0.1 to 20.0	-	0.1	2.0		12	Y
	F10	Electronic (Select)	F10 ELCTRN OL1	0, 1, 2	-	-	1		3	Y
	F11	Thermal 1 (level)	F11 OL LEVEL1	20 to 135% of drive rated current	A	0.01	Motor rated current		1	Y
	F12	(time constant)	F12 TIME CNST1	0.5 to 75.0 min	min	0.1	5.0	10.0	19	Y
	F13	Electronic thermal overload relay (for braking resistor)	F13 DBR OL	[Up to 10 HP] 0, 1, 2 [15 HP and above] 0	-	-	1 0		3	Y
5-12	F14	Restart mode after momentary power failure	F14 RESTART	0 to 5	-	-	0		1	N
5-14	F15	Frequency (high)	F15 H LIMITER	0 to 400 Hz	Hz	1	70		1	Y
	F16	Limitier (low)	F16 L LIMITER				0		1	N
	F17	Gain (for frequency set signal)	F17 FREQ GAIN	0.0 to 200.0%	%	0.1	100.0		1	Y
	F18	Bias frequency	F18 FREQ BIAS	-400.0 to +400.0 Hz	Hz	0.1	0.0		1	Y
	F20	DC brake (starting frequency)	F20 DC BRK Hz	0.0 to 60.0 Hz	Hz	0.1	0.0		3	Y
	F21	(braking level)	F21 DC BRK LVL	0 to 100%	%	1	0		1	
F22	(braking time)	F22 DC BRK t	0.0s (inactive)	s	0.1	0.0		3		
5-15	F23	Starting frequency	F23 START Hz	0.1 to 60.0 Hz	Hz	0.1	0.5		3	N
	F24	(holding time)	F24 HOLDING t	0.0 to 10.0 s	s	0.1	0.0		3	
	F25	Stop frequency	F25 STOP Hz	0.1 to 6.0 Hz	Hz	0.1	0.2		1	
	F26	Motor sound (carrier freq.)	F26 MTR SOUND	0.75 to 15 kHz	kHz	1	2		1	Y
	F27	(sound tone)	F27 SOUND TONE	0 to 3	-	-	0		1	Y
5-16	F30	FMA (voltage adjust)	F30 FMA V-ADJ	0 to 200%	%	1	100		1	Y
	F31	(function)	F31 FMA FUNC	0 to 10	-	-	0		1	Y
5-16	F33	FMP (pulse rate)	F33 FMP PULSES	300 to 6000 p/s (full scale)	p/s	1	1440		1	Y
	F34	(voltage adjust)	F34 FMP V-ADJ	0%, 1 to 200%	%	1	0		1	Y
	F35	(function)	F35 FMP FUNC	0 to 10	-	-	0		1	Y
	F36	30RY operation mode	F36 30RY MODE	0, 1	-	-	0		1	Y
	F40	Torque limiter1 (driving)	F40 DRV TRQ 1	20 to 200%, 999	%	1	999		1	Y
F41	(braking)	F41 BRK TRQ 1	0%, 20 to 200%, 999			999		1		
5-17	F42	Torque vector control 1	F42 TRQVECTOR1	0, 1	-	-	0		1	N

E:Terminal Extension Functions

Pg.	Func. No.	Name	LCD Display	Setting Range	Unit	Min.	Factory Setting		Data Format	Change During op	
							30 HP	40 HP			
5-18/21	E01	X1 terminal function	E01 X1 FUNC	0 to 32					0	1	N
	E02	X2 terminal function	E02 X2 FUNC						1	1	N
	E03	X3 terminal function	E03 X3 FUNC						2	1	N
	E04	X4 terminal function	E04 X4 FUNC						3	1	N
	E05	X5 terminal function	E05 X5 FUNC						4	1	N
	E06	X6 terminal function	E06 X6 FUNC						5	1	N
	E07	X7 terminal function	E07 X7 FUNC						6	1	N
	E08	X8 terminal function	E08 X8 FUNC						7	1	N
	E09	X9 terminal function	E09 X9 FUNC						8	1	N
5-22	E10	Acceleration time 2	E10 ACC TIME2	0.01 to 3600 s	s	0.01	6.00	20.00	12	Y	
	E11	Deceleration time 2	E11 DEC TIME2				6.00	20.00	12	Y	
	E12	Acceleration time 3	E12 ACC TIME3				6.00	20.00	12	Y	
	E13	Deceleration time 3	E13 DEC TIME3				6.00	20.00	12	Y	
	E14	Acceleration time 4	E14 ACC TIME4				6.00	20.00	12	Y	
	E15	Deceleration time 4	E15 DEC TIME4				6.00	20.00	12	Y	
	E16	Torque limiter 2 (driving)	E16 DRV TRQ.2				20 to 200%, 999	%	1	999	
E17	(braking)	E17 BRK TRQ.2	0%, 20 to 200%, 999	%	1	999		1	Y		
5-22/24	E20	Y1 terminal function	E20 Y1 FUNC	0 to 33					0	1	N
	E21	Y2 terminal function	E21 Y2 FUNC						1	1	N
	E22	Y3 terminal function	E22 Y3 FUNC						2	1	N
	E23	Y4 terminal function	E23 Y4 FUNC						7	1	N
	E24	Y5A, Y5C terminal function	E24 Y5 FUNC						10	1	N
5-24	E25	Y5 RY operation mode	E25 Y5RY MODE	0,1	-	1	0	1	N		
5-25	E30	FAR function (Hysteresis)	E30 FAR HYSTR	0.0 to 10.0 Hz	Hz	0.1	2.5	3	Y		
	E31	FDT function (level)	E31 FDT1 LEVEL	0 to 400 Hz	Hz	1	60	1	Y		
	E32	signal (Hysteresis)	E32 FDT1 HYSTR	0.0 to 30.0 Hz	Hz	0.1	1.0	3			
	E33	OL function (mode select)	E33 OL1 WARNING	0: Thermal calculation 1: Output current	-	-	0	1			
	E34	signal (l (level)	E34 OL1 LEVEL	5 to 200% of rated drive current	A	0.01	motor rated current	19		Y	
	E35	(timer)	E35 OL1 TIMER	0.1 to 60.0 s	s	0.1	10.0	3			
	E36	FDT2 function (level)	E36 FDT2 LEVEL	0 to 400 Hz	Hz	1	60	1			
E37	OL2 function (level)	E37 OL2 LEVEL	5 to 200% of rated drive current	A	0.01	motor rated current	19		Y		
5-26	E40	Display coefficient A	E40 COEF A	-999.00 to 999.00	-	0.01	0.01	12			
	E41	Display coefficient B	E41 COEF B	-999.00 to 999.00	-	0.01	0.00	12	Y		
	E42	LED Display filter	E42 DISPLAY FL	0.0 to 5.0 s	s	0.1	0.5	3	Y		
	E43	LED Monitor (function)	E43 LED MNTR	0 to 12	-	-	0	1	Y		
	E44	(display in STOP mode)	E44 LED MNTR2	0, 1	-	-	0	1	Y		
5-27	E45	LCD Monitor (function)	E45 LCD MNTR	0, 1	-	-	0	1	Y		
	E46	(language)	E46 LANGUAGE	0 to 5	-	-	1	1	Y		
	E47	(contrast)	E47 CONTRAST	0(soft) to 10(hard)	-	-	5	1	Y		

C:Frequency Control Functions

	C01	Jump (Jump freq. 1)	C01 JUMP Hz 1	0 to 400 Hz	Hz	1	0	1	Y
	C02	frequency (Jump freq. 2)	C02 JUMP Hz 2				0	1	
	C03	(Jump freq. 3)	C03 JUMP Hz 3				0	1	
	C04	(Hysteresis)	C04 JUMP HYSTR				0 to 30 Hz	Hz	
5-28	C05	Multistep (Freq. 1)	C05 MULTI Hz-1	0.00 to 400.00 Hz	Hz	0.01	0.00	5	Y
	C06	frequency (Freq. 2)	C06 MULTI Hz-2				0.00	5	
	C07	setting (Freq. 3)	C07 MULTI Hz-3				0.00	5	
	C08	(Freq. 4)	C08 MULTI Hz-4				0.00	5	
	C09	(Freq. 5)	C09 MULTI Hz-5				0.00	5	
	C10	(Freq. 6)	C10 MULTI Hz-6				0.00	5	
	C11	(Freq. 7)	C11 MULTI Hz-7				0.00	5	
	C12	(Freq. 8)	C12 MULTI Hz-8				0.00	5	
	C13	(Freq. 9)	C13 MULTI Hz-9				0.00	5	
	C14	(Freq. 10)	C14 MULTI Hz-10				0.00	5	
	C15	(Freq. 11)	C15 MULTI Hz-11				0.00	5	
	C16	(Freq. 12)	C16 MULTI Hz-12				0.00	5	
	C17	(Freq. 13)	C17 MULTI Hz-13				0.00	5	
	C18	(Freq. 14)	C18 MULTI Hz-14				0.00	5	
	C19	(Freq. 15)	C19 MULTI Hz-15				0.00	5	

Pg.	Func. No.	Name	LCD Display	Setting Range	Unit	Min.	Factory Setting		Data Format	Change During op
							30 HP	40 HP		
5-29	C20	JOG frequency	C20 JOG Hz	0.00 to 400.00 Hz	Hz	0.01	5.00		5	Y
	C21	PATTERN (mode select) operation	C21 PATTERN	0,1,2	-	-	0		1	N
5-29/30	C22	(Stage 1)	C22 STAGE 1	Operation time: 0.00 to 6000 s F1 to F4 and R1 to R4	s	0.01	0.00 F1		13	Y
	C23	(Stage 2)	C23 STAGE 2				0.00 F1		13	
	C24	(Stage 3)	C24 STAGE 3				0.00 F1		13	
	C25	(Stage 4)	C25 STAGE 4				0.00 F1		13	
	C26	(Stage 5)	C26 STAGE 5				0.00 F1		13	
	C27	(Stage 6)	C27 STAGE 6				0.00 F1		13	
	C28	(Stage 7)	C28 STAGE 7				0.00 F1		13	
5-30	C30	Frequency command 2	C30 FREQ CMD 2	0 to 11	-	-	2		1	N
	C31	Offset adjust (terminal [12])	C31 BIAS 12	-100.0 to +100.0%	%	0.1	0.0		4	Y
	C32	(terminal [C1])	C32 GAIN 12	0.0 to +200.0%	%	0.1	100.0		3	Y
5-31	C33	Analog setting signal filter	C33 REF FILTER	0.00 to 5.00s	s	0.01	0.05		5	Y

P:Motor Parameters

5-32	P01	Number of motor 1 poles	P01 M1 POLES	2 to 14	-	2	4		9	N
	P02	Motor 1 (capacity)	P02 M1-CAP	Up to 30 HP: 0.01 to 60 HP 40 HP and above: 0.01 to 600 HP	Hp	0.01	motor capacity		5	N
	P03	(rated current)	P03 M1-Ir	0.00 to 2000 A	A	0.01	motor rated current		19	N
	P04	(tuning)	P04 M1 TUN1	0, 1, 2	-	-	0		21	N
5-33	P05	(on-line tuning)	P05 M1 TUN2	0, 1	-	-	0		1	N
	P06	(no-load current)	P06 M1-Io	0.00 to 2000 A	A	0.01	standard rated value		19	N
	P07	(%R1 setting)	P07 M1-%R1	0.00 to 50.00%	%	0.01	standard rated value		5	Y
	P08	(%X setting)	P08 M1-%X	0.00 to 50.00%	%	0.01	standard rated value		5	Y
	P09	Slip compensation control	P09 SLIP COMP1	0.00 to 15.00 Hz	Hz	0.01	0.00		5	Y

H:High Performance Functions

5-34	H03	Data initializing	H03 DATA INIT	0, 1	-	-	0		1	N	
	H04	Auto-reset (times)	H04 AUTO-RESET	0, 1 to 10 times	-	1	0		1	Y	
	H05	(reset interval)	H05 RESET INT	2 to 20 s	s	1	5		1	Y	
	H06	Fan stop operation	H06 FAN STOP	0, 1	-	-	0		1	Y	
	H07	ACC/DEC pattern (mode select)	H07 ACC PTN	0,1,2,3	-	-	0		1	N	
	5-35	H08	Rev. phase sequence lock	H08 REV LOCK	0, 1	-	-	0		1	N
		H09	Start mode	H09 START MODE	0, 1, 2	-	--	0		1	N
5-36	H10	Energy-saving operation	H10 ENERGY SAV	0, 1	-	-	0		1	Y	
	H11	DEC mode	H11 DEC MODE	0, 1	-	-	0		1	Y	
	H12	Instantaneous OC limiting	H12 INST CL	0, 1	-	-	1		1	N	
	H13	Auto-restart (restart time)	H13 RESTART t	0.1 to 10.0 s	s	0.1	0.1	0.5	3	N	
	H14	(freq. fall rate)	H14 FALL RATE	0.00 to 100.00 Hz/s	Hz/s	0.01	10.00		5	Y	
H15	(holding DC voltage)	H15 HOLD V	3-phase, 230V class: 200 to 300V 3-phase, 460V class: 400 to 600V	V	1	200V class: 235V 400V class: 470V		1			
5-37	H16	(OPR command self hold time)	H16 SELFHOLD t	0.0 to 30.0 s, 999	s	0.1	999		3	N	
	H18	Torque control	H18 TRQ CTRL	0, 1, 2	-	-	0		1	Y	
	H19	Active drive	H19 AUT RED	0, 1	-	-	0		1	Y	
5-38	H20	PID control (mode select)	H20 PID MODE	0, 1, 2	--	-	0		1	N	
	H21	(feedback signal)	H21 FB SIGNAL	0, 1, 2, 3	-	-	1		1	N	
5-39/40	H22	(P-gain)	H22 P-GAIN	0.01 to 10.00 times	-	0.01	0.1		5	Y	
	H23	(I-gain)	H23 I-GAIN	0.0, 0.1 to 3600 s	s	0.1	0.0		3	Y	
	H24	(D-gain)	H24 D-GAIN	0.00 s, 0.01 to 10.0 s	s	0.01	0.00		5	Y	
5-41	H25	(feedback filter)	H25 FB FILTER	0.0 to 60.0 s	s	0.1	0.5		3	Y	
	H26	PTC thermistor (mode select)	H26 PTC MODE	0, 1	-	-	0		1	Y	
	H27	(level)	H27 PTC LEVEL	0.00 to 5.00V	V	0.01	1.60		5	Y	
	H28	Droop operation	H28 DROOP	9.9 to 0.0 Hz	Hz	0.1	0.0		4	Y	
	H30	Serial link (function select)	H30 LINK FUNC	0, 1, 2, 3	-	-	0		1	Y	
5-42	H31	Modbus-RTU (address)	H31 ADDRESS	0 (broadcast), 1 to 247	-	1	1		1	N	
	H32	(mode select on no response error)	H32 MODE ON ER	0, 1, 2, 3	-	-	0		1	Y	
	H33	(timer)	H33 TIMER	0.0 to 60.0 s	s	-	2.0		3	Y	
	H34	(baud rate)	H34 BAUD RATE	0, 1, 2, 3	-	-	1		1	Y	
	H35	(data length)	H35 LENGTH	0 (8-bit fixed)	-	-	0		1	Y	
	H36	(parity check)	H36 PARITY	0, 1, 2	-	-	0		1	Y	
	H37	(stop bits)	H37 STOP BITS	0 (2-bit), 1(1-bit)	-	-	0		1	Y	
5-43	H38	(no response error detection time)	H38 NO RES t	0 (no detection), 1 to 60 s	s	1	0		1	Y	
	H39	(response interval)	H39 INTERVAL	0.00 to 1.00 s	s	0.01	0.01		5	Y	

A. Alternative Motor Parameters

A: Alternative Motor Parameters

Pg.	Func. No.	Name	LCD Display	Setting Range	Unit	Min.	Factory Setting		Data Format	Change During op
							30 HP	40 HP		
5-44	A01	Maximum frequency 2	A01 MAX Hz-2	50 to 400 Hz	Hz	1	60		1	N
	A02	Base frequency 2	A02 BASE Hz-2	25 to 400 Hz	Hz	1	60		1	N
	A03	Rated voltage 2 (at Base frequency 2)	A03 RATED V-2	0 230V class: 80 to 240V 460V class: 320 to 480V	V	1	230V class: 230 460V class: 460		1	N
	A04	Maximum voltage 2	A04 MAX V-2	230V class: 80 to 240V 460V class: 320 to 480V	V	1	230V class: 230 460V class: 460		1	N
	A05	Torque boost 2	A05 TRQ BOOST2	0.0, 0.1 to 20.0	-	-	2.0		3	Y
	A06	Electronic (select)	A06 ELCTRN OL2	0, 1, 2	-	-	1		1	Y
	A07	thermal 2 (level)	A07 OL LEVEL2	20% to 135% if INV rated current	A	0.01	motor rated current		19	Y
	A08	(thermal time constant)	A08 TIME CNST2	0.5 to 75.0 min	min	0.1	5.0	10.0	3	Y
	A09	Torque vector control 2	A09 TRQVECTOR2	0, 1	-	-	0		1	N
	A10	Number of motor 2 poles	A10 M2 POLES	2 to 14 poles	pole	2	4		9	N
5-45	A11	Motor 2 (capacity)	A11 M2-CAP	Up to 30 HP: 0.01 to 60 HP 40 HP and above: 0.01 to 600 HP	HP	0.01	motor capacity		5	N
	A12	(rated current)	A12 M2-Ir	0.00 to 2000 A	A	0.01	motor rated current		19	N
	A13	(tuning)	A13 M2 TUN1	0, 1, 2	-	-	0		21	N
	A14	(on-line tuning)	A14 M2 TUN2	0, 1	-	-	0		1	N
	A15	(no-load current)	A15 M2-lo	0.00 to 2000 A	A	0.01	standard rated value		19	N
	A16	(%R1 setting)	A16 M2-%R1	0.00 to 50.00%	%	0.01	standard rated value		5	Y
	A17	(%X setting)	A17 M2-%X	0.00 to 50.00%	%	0.01	standard rated value		5	Y
	A18	(slip compensation control 2)	A18 SLIP COMP2	0.00 to 15.00 Hz	Hz	0.01	0.00		5	Y

5.2 Alphabetical Function List

PG.	NAME	LCD Display	PG.	NAME	LCD Display
5-16	30RY operation mode	F36 30RY MODE	5-26	LED Monitor (Display @ STOP mode)	E44 LED MNTR2
5-10	Acceleration time 1	F07 ACC TIME1	5-10	Maximum frequency 1	F03 MAX Hz-1
5-22	Acceleration time 2	E10 ACC TIME2	5-44	Maximum frequency 2	A01 MAX Hz-2
5-22	Acceleration time 3	E12 ACC TIME3	5-10	Maximum voltage 1	F06 MAX V-1
5-22	Acceleration time 4	E14 ACC TIME4	5-44	Maximum voltage 2	A04 MAX V-2
5-34	ACC/DEC Pattern	H07 ACC PTN	5-42	Modbus-RTU (Address)	H31 ADDRESS
5-37	Active Drive	H19 AUT RED	5-42	Modbus-RTU (Baud rate)	H34 BAUD RATE
5-31	Analog setting signal filter	C33 REF FILTER	5-42	Modbus-RTU (Data length)	H35 LENGTH
5-10	Base frequency 1	F04 BASE Hz-1	5-42	Modbus-RTU (Mode select on no response error)	H32 MODE ON ER
5-44	Base frequency 2	A02 BASE Hz-2	5-43	Modbus-RTU (No response error detection time)	H38 NO RES t
5-14	Bias frequency	F18 FREQ BIAS	5-42	Modbus-RTU (Parity check)	H36 PARITY
5-34	Data initializing	H03 DATA INIT	5-43	Modbus-RTU (Response interval)	H39 INTERVAL
5-7	Data protection	F00 DATA PRTC	5-42	Modbus-RTU (Stop bits)	H37 STOP BITS
5-14	DC brake (Braking level)	F21 DC BRK LVL	5-42	Modbus-RTU (Timer)	H33 TIMER
5-14	DC brake (Braking time)	F22 DC BRK t	5-33	Motor 1 (%R1 setting)	P07 M1-%R1
5-14	DC brake (Starting freq.)	F20 DC BRK Hz	5-33	Motor 1 (%X setting)	P08 M1-%X
5-36	DEC mode	H11 DEC MODE	5-32	Motor 1 (Capacity)	P02 M1 -CAP
5-10	Deceleration time 1	F08 DEC TIME1	5-33	Motor 1 (No-load current)	P06 M1-lo
5-22	Deceleration time 2	E11 DEC TIME2	5-33	Motor 1 (On-line Tuning)	P05 M1 TUN2
5-22	Deceleration time 3	E13 DEC TIME3	5-32	Motor 1 (Rated current)	P03 M1-Ir
5-22	Deceleration time 4	E15 DEC TIME4	5-32	Motor 1 (Tuning)	P04 M1 TUN1
5-26	Display coefficient A	E40 COEF A	5-45	Motor 2 (%R1 setting)	A16 M2-%R1
5-26	Display coefficient B	E41 COEF B	5-45	Motor 2 (%X setting)	A17 M2-%X
5-41	Droop operation	H28 DROOP	5-44	Motor 2 (Capacity)	A11 M2-CAP
5-11	Electronic Thermal 1 (Level)	F11 OL LEVEL1	5-45	Motor 2 (No-load current)	A15 M2-lo
5-11	Electronic Thermal 1 (Select)	F10 ELCTRN OL1	5-45	Motor 2 (On-line Tuning)	A14 M2 TUN2
5-11	Electronic Thermal 1 (Thermal time constant)	F12 TIME CNST1	5-44	Motor 2 (Rated current)	A12 M2-Ir
5-44	Electronic thermal 2 (Level)	A07 OL LEVEL2	5-45	Motor 2 (Slip compensation control 2)	A18 SLIP COMP2
5-44	Electronic thermal 2 (Select)	A06 ELCTRN OL2	5-45	Motor 2 (Tuning)	A13 M2 TUN1
5-44	Electronic thermal 2 (Thermal time constant)	A08 TIME CNST2	5-15	Motor sound (Carrier freq.)	F26 MTR SOUND
5-11	Electronic thermal overload relay (for DB resistor)	F13 DBR OL	5-15	Motor sound (Sound tone)	F27 SOUND TONE
5-36	Energy-saving operation	H10 ENERGY SAV	5-28	Multistep frequency setting (Freq. 1)	C05 MULTI Hz-1
5-34	Fan stop operation	H06 FAN STOP	5-28	Multistep frequency setting (Freq. 2)	C06 MULTI Hz-2
5-25	FAR function (Hysteresis)	E30 FAR HYSTR	5-28	Multistep frequency setting (Freq. 3)	C07 MULTI Hz-3
5-25	FDT function (Level)	E31 FDT1 LEVEL	5-28	Multistep frequency setting (Freq. 4)	C08 MULTI Hz-4
5-25	FDT signal (Hysteresis)	E32 FDT1 HYSTR	5-28	Multistep frequency setting (Freq. 5)	C09 MULTI Hz-5
5-25	FDT2 function (Level)	E36 FDT2 LEVEL	5-28	Multistep frequency setting (Freq. 6)	C10 MULTI Hz-6
5-15	FMA (Voltage adjust)	F30 FMA V-ADJ	5-28	Multistep frequency setting (Freq. 7)	C11 MULTI Hz-7
5-15	FMA (Function)	F31 FMA FUNC	5-28	Multistep frequency setting (Freq. 8)	C12 MULTI Hz-8
5-16	FMP (Function)	F35 FMP FUNC	5-28	Multistep frequency setting (Freq. 9)	C13 MULTI Hz-9
5-16	FMP (Pulse rate)	F33 FMP PULSES	5-28	Multistep frequency setting (Freq.10)	C14 MULTI Hz-10
5-16	FMP (Voltage adjust)	F34 FMP V-ADJ	5-28	Multistep frequency setting (Freq.11)	C15 MULTI Hz-11
5-7	Frequency command 1	F01 FREQ CMD 1	5-28	Multistep frequency setting (Freq.12)	C16 MULTI Hz-12
5-30	Frequency command 2	C30 FREQ CMD 2	5-28	Multistep frequency setting (Freq.13)	C17 MULTI Hz-13
5-14	Frequency limiter (High)	F15 H LIMITER	5-28	Multistep frequency setting (Freq.14)	C18 MULTI Hz-14
5-14	Frequency limiter (Low)	F16 L LIMITER	5-28	Multistep frequency setting (Freq.15)	C19 MULTI Hz-15
5-14	Gain (for freq set signal)	F17 FREQ GAIN			
5-36	Instantaneous OC limiting	H12 INST CL			
5-29	JOG frequency	C20 JOG Hz			
5-28	Jump frequency (Hysteresis)	C04 JUMP HYSTR			
5-28	Jump frequency (Jump freq 1)	C01 JUMP Hz 1			
5-28	Jump frequency (Jump freq 2)	C02 JUMP Hz 2			
5-28	Jump frequency (Jump freq 3)	C03 JUMP Hz 3			
5-27	LCD Monitor (Contrast)	E47 CONTRAST			
5-27	LCD Monitor (Function)	E45 LCD MNTR			
5-27	LCD Monitor (Language)	E46 LANGUAGE			
5-26	LED Display filter	E42 DISPLAY FL			
5-26	LED Monitor (Function)	E43 LED MNTR			

5.2 Alphabetical Function List (continued)

PG.	NAME		LCD Display
5-32	Number of motor 1 poles	P01	M1 POLES
5-44	Number of motor 2 poles	A10	M2 POLES
5-30	Offset adjust (terminal [12])	C31	BIAS 12
5-30	Offset adjust (terminal [C1])	C32	GAIN 12
5-25	OL function (Mode select)	E33	OL1 WARNING
5-25	OL function signal (Timer)	E35	OL1 TIMER
5-25	OL function signal (Level)	E34	OL1 LEVEL
5-25	OL2 function (Level)	E37	OL2 LEVEL
5-7	Operation method	F02	OPR METHOD
5-29	Pattern (Stage 1)	C22	STAGE 1
5-29	Pattern (Stage 2)	C23	STAGE 2
5-29	Pattern (Stage 3)	C24	STAGE 3
5-29	Pattern (Stage 4)	C25	STAGE 4
5-29	Pattern (Stage 5)	C26	STAGE 5
5-29	Pattern (Stage 6)	C27	STAGE 6
5-29	Pattern (Stage 7)	C28	STAGE 7
5-29	PATTERN operation (Mode select)	C21	PATTERN
5-39	PID control (D-gain)	H24	D-GAIN
5-41	PID control (Feedback filter)	H25	FB FILTER
5-38	PID control (Feedback signal)	H21	FB SIGNAL
5-39	PID control (I-gain)	H23	I-GAIN
5-37	PID control (Mode select)	H20	PID MODE
5-39	PID control (P-gain)	H22	P-GAIN
5-41	PTC thermistor (Level)	H27	PTC LEVEL
5-41	PTC thermistor (Mode select)	H26	PTC MODE
5-10	Rated voltage 1	F05	RATED V-1
5-44	Rated voltage 2 (at Base frequency 2)	A03	RATED V-2
5-12	Restart mode after momentary power failure	F14	RESTART
5-35	Rev. phase sequence lock	H08	REV LOCK
5-42	Serial link (Function select)	H30	LINK FUNC
5-33	Slip compensation control	P09	SLIP COMP1
5-35	Start mode	H09	START MODE
5-15	Starting frequency (Freq.)	F23	START Hz
5-15	Starting frequency (Holding time)	F24	HOLDING t
5-15	Stop frequency	F25	STOP Hz
5-11	Torque boost 1	F09	TRQ BOOST1
5-44	Torque boost 2	A05	TRQ BOOST2
5-37	Torque control	H18	TRQ CTRL
5-16	Torque limiter 1 (braking)	F41	BRK TRQ 1
5-16	Torque limiter 1 (Driving)	F40	DRV TRQ 1
5-22	Torque limiter 2 (braking)	E17	BRK TRQ 2
5-22	Torque limiter 2 (Driving)	E16	DRV TRQ 2
5-177	Torque vector control 1	F42	TRQVECTOR1
5-44	Torque vector control 2	A09	TRQVECTOR2
5-18	X1 terminal function	E01	X1 FUNC
5-18	X2 terminal function	E02	X2 FUNC
5-18	X3 terminal function	E03	X3 FUNC
5-18	X4 terminal function	E04	X4 FUNC
5-18	X5 terminal function	E05	X5 FUNC
5-18	X6 terminal function	E06	X6 FUNC
5-18	X7 terminal function	E07	X7 FUNC
5-22	Y1 terminal function	E20	Y1 FUNC
5-22	Y2 terminal function	E21	Y2 FUNC
5-22	Y3 terminal function	E22	Y3 FUNC
5-22	Y4 terminal function	E23	Y4 FUNC
5-24	Y5 RY operation mode	E25	Y5RY MODE
5-22	Y5A, Y5C terminal func.	E24	Y5 FUNC

5.3 Function Explanation

F: Fundamental function

F00 Data protection

F 0 0 D A T A P R T C

Set value 0: data can be changed
1: data cannot be changed

This function protects the system by blocking any data changes from the keypad panel.

Setting procedure:

0 to 1: Press the **STOP** and **▲** keys simultaneously to change the value from 0 to 1, then press

the **FUNC DATA** to validate the change.

1 to 0: Press the **STOP** and **▼** keys simultaneously to change the value from 1 to 0, then press

the **FUNC DATA** key to validate the change.

F01 Frequency setting 1

F 0 1 F R E Q C M D 1

This function determines the method to be used for setting frequency.

Note: Use only one Terminal - V2 or C1, exclusively.

- 0: Keypad operation (**▼** or **▲** key)
- 1: Voltage input (Terminals 12 and V2) (0 to +10 VDC, 0 to +5VDC)
- 2: Current input (Terminal C1) (4 to 20 mA DC)
- 3: Voltage and current input (Terminals 12 and C1)
- 4: Reverse operation with polarity (Terminal 12) (0 to ± 10 VDC)
- 5: Reverse operation with polarity (Terminal 12 and V2) (0 to ± 10 VDC)

Related Functions E01 to E09 (Set value 21)

- 6: Inverse mode operation (Terminals 12 and V2) (+10 to 0 VDC)
- 7: Inverse mode operation (Terminal C1)(20 to 4 mA DC)
- 8: UP/DOWN control 1 (initial frequency = 0 Hz)
- 9: UP/DOWN control 2 (initial frequency = last value)

Related Functions E01 to E09 (Set values 17, 18)

- 10. PATTERN operation

Related Functions: C21 to C28

- 11: DI option or Pulse train input

For details, see instruction manual on options.

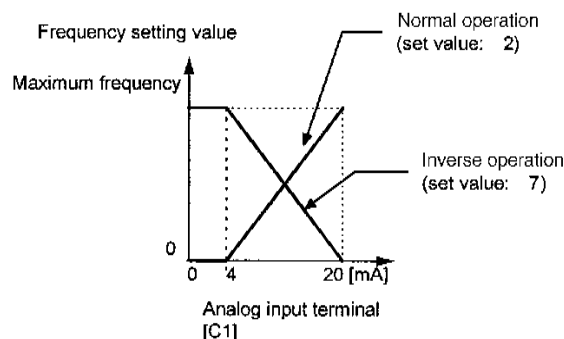
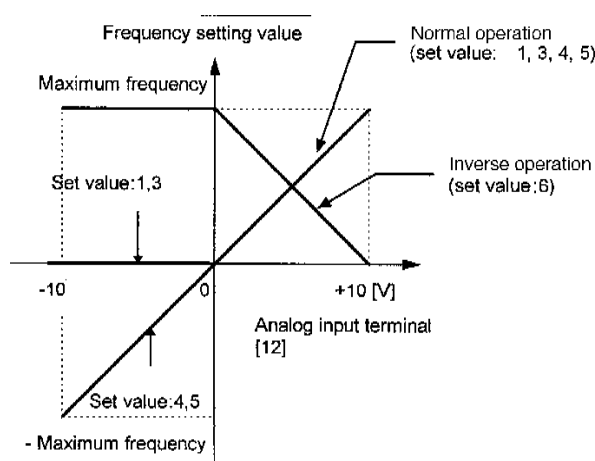

F02 Operation method

F 0 2 O P R M E T H O D

This function determines the input method for operation commands.

- 0: Keypad operation (**FWD** or **REV** or **STOP** key)
- 1: Terminal operation (**STOP** key active)
- 2: Terminal operation (**STOP** key inactive)
- 3: Terminal operation (**STOP** key active) with special start software
- 4: Terminal operation (**STOP** key inactive) with special start software

This function can only be changed when Terminals **FWD** and **REV** are open.

REMOTE/LOCAL switching from the keypad panel automatically changes the set value from 0 to 3 of this function.

Comm Start Software Selection During Terminal Operation

	Inactive: Setting 1 or 2	Active: Setting 3 or 4
POWER ON	<p>Timing diagram for Power On (Inactive: Setting 1 or 2). The signals are: POWER (high), FWD (high), OUTPUT (ramp up), and ALARM (low).</p>	<p>Timing diagram for Power On (Active: Setting 3 or 4). The signals are: POWER (high), FWD (high), OUTPUT (low), and ALARM (ER6 pulse).</p>
RESET	<p>Timing diagram for Reset (Inactive: Setting 1 or 2). The signals are: RESET (pulse), FWD (high), OUTPUT (ramp up), and ALARM (low).</p>	<p>Timing diagram for Reset (Active: Setting 3 or 4). The signals are: RESET (pulses), FWD (high), OUTPUT (ramp up), and ALARM (Multi Alarms* pulse).</p>
NETWORK MODE	<p>Timing diagram for Network Mode (Inactive: Setting 1 or 2). The signals are: NETWORK (LE-CM) (high), FWD (TERMINAL) (high), FWD (NETWORK) (high), OUTPUT (ramp up), and ALARM (low).</p>	<p>Timing diagram for Network Mode (Active: Setting 3 or 4). The signals are: NETWORK (LE-CM) (high), FWD (TERMINAL) (high), FWD (NETWORK) (high), OUTPUT (ramp up), and ALARM (ER6 pulses). A RESET pulse is shown below the ALARM signal.</p>

* See Alarm Mode, page 4-15.

Note: Start Software does not work in AUTO RESET mode or PROGRAMMING mode.

Stop Key Mode Selection During Terminal Operation

	Inactive: Setting 2 or 4	Active: Setting 1 or 3
STOP KEY TERMINAL MODE	<p>Timing diagram for Stop Key Terminal Mode (Inactive: Setting 2 or 4). The signals are: FWD (high), STOP (pulse), OUTPUT (ramp up), and ALARM (low).</p>	<p>Timing diagram for Stop Key Terminal Mode (Active: Setting 1 or 3). The signals are: FWD (high), STOP (pulse), OUTPUT (ramp down), and ALARM (ER6 pulse).</p>
STOP KEY NETWORK MODE	<p>Timing diagram for Stop Key Network Mode (Inactive: Setting 2 or 4). The signals are: NETWORK (LE-CM) (high), FWD (TERMINAL) (high), STOP (pulse), OUTPUT (ramp down), and ALARM (low).</p>	<p>Timing diagram for Stop Key Network Mode (Active: Setting 1 or 3). The signals are: NETWORK (LE-CM) (high), FWD (TERMINAL) (high), STOP (pulse), OUTPUT (ramp down), and ALARM (ER6 pulse).</p>

Frequency Setting Block Diagram

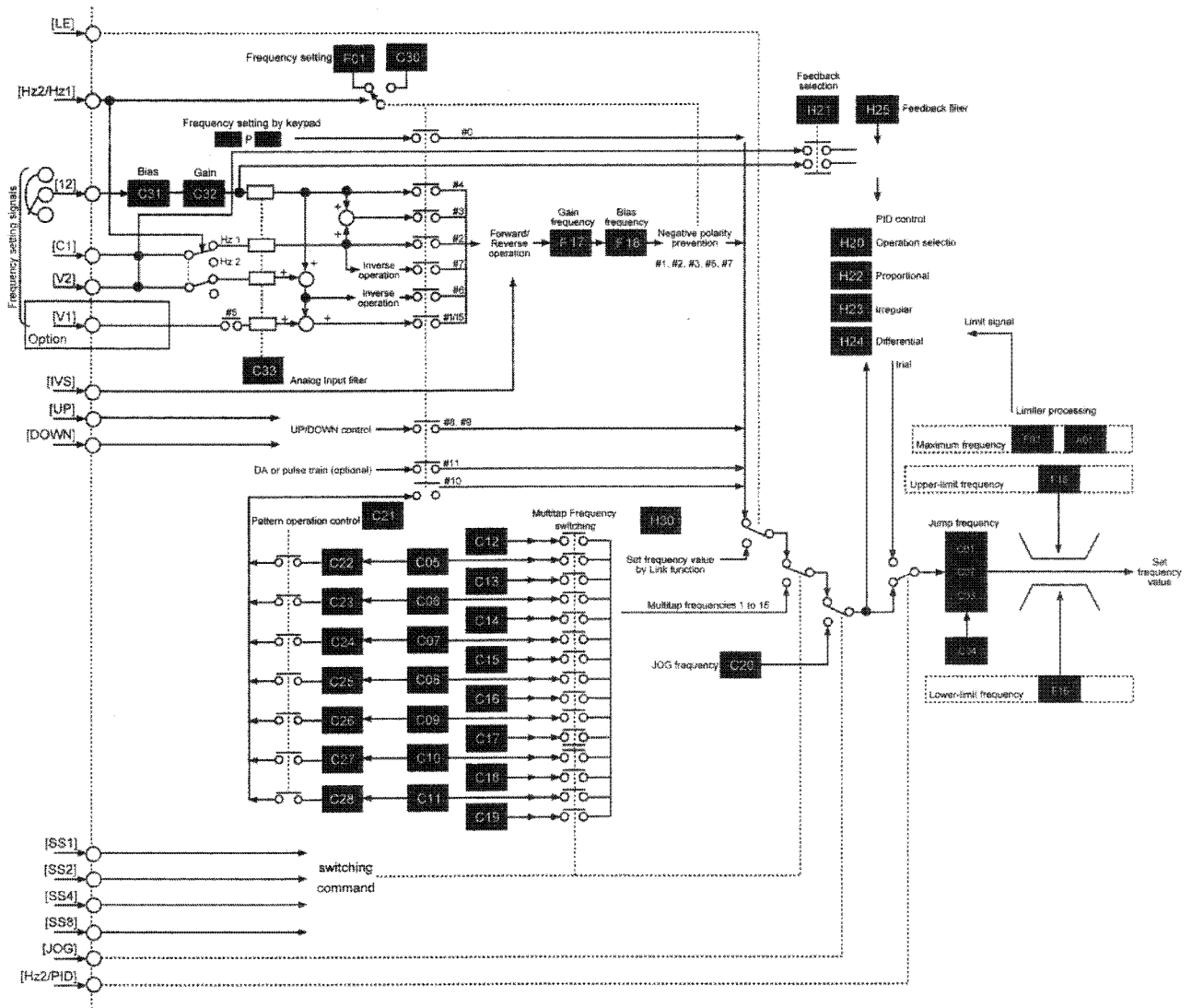

F03 Maximum output frequency 1

F 0 3 M A X H z 1

Setting range: 50 to 400 Hz

This function sets the maximum output frequency for Motor 1.

Setting a value higher than the rated value of the device to be driven may damage the motor or machine. Match the device rating when setting this function.

F04 Base frequency 1

F 0 4 B A S E H z 1

Setting range: 25 to 400 Hz

This function sets the maximum output frequency in the constant torque range of Motor 1 or the output frequency at the rated output voltage. Match the motor rating.

Note: If the value of Base frequency 1 is set higher than that of Maximum output frequency 1, the output voltage does not increase to the rated voltage. The maximum frequency limits the output frequency.

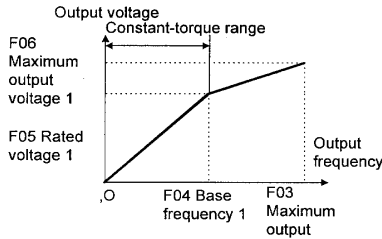

F05 Rated voltage 1

F 0 5 R A T E D V 1

Setting range 230 V AC series: 0, 80 to 240V
 460 V AC series: 0, 320 to 480V

This function sets the rated value of the voltage output to Motor 1. Note that a voltage greater than the supply (input) voltage cannot be output.

Value 0 terminates operation of the voltage regulator function, thereby resulting in the output of a voltage proportional to the supply voltage.

Note: If the value of Rated voltage 1 is set higher than Maximum output voltage 1, the output voltage does not increase to the rated voltage. The maximum output voltage limits the output voltage.

F06 Maximum output voltage 1

F 0 6 M A X V 1

Setting range 230 VAC series: 80 to 240 VAC
 460 VAC series: 320 to 480 VAC

This function sets the maximum value of the voltage output for Motor 1. Note that a voltage higher than the supply (input) voltage cannot be output.

F07 Acceleration time 1

F08 Deceleration time 1

F 0 7 A C C T I M E 1
F 0 8 D E C T I M E 1

Setting range ACC TIME1: 0.01 to 3,600 seconds
 DEC TIME1: 0.01 to 3,600 seconds

These functions set the acceleration time for the output frequency from startup to maximum frequency, as well as the deceleration time from maximum frequency to operation stop.

Acceleration and deceleration times are represented by the three most significant (high-order) digits.

Set acceleration and deceleration times with respect to maximum frequency. The relationship between the set frequency value and acceleration/deceleration times is as follows:

Set frequency = maximum frequency

The actual operation time matches the set value.

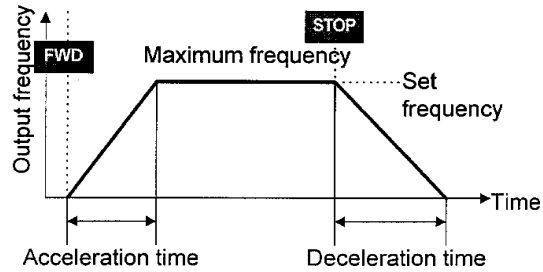

Set frequency < maximum frequency

The actual operation time differs from the set value.

Acceleration * deceleration operation time = set value x (set frequency / maximum frequency)

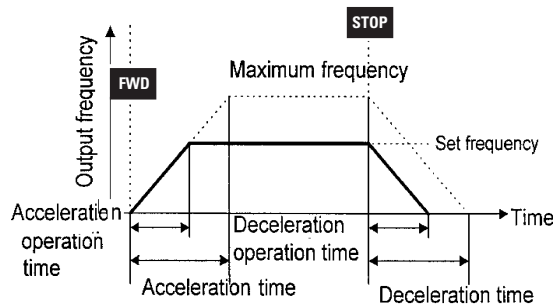

Note: If the set acceleration and deceleration times are set too low, even though the resistance torque and moment of inertia of the load are great, the torque limiting function or stall prevention function activates, which prolongs the operation time beyond that stated above.

F14 Restart after momentary power failure (operation selection)

F 1 4 R E S T A R T

Setting range: 0 to 5

The following table lists the function details.

This function selects operation if a momentary power failure occurs.

The function for detecting power failure and activating protective operation (i.e., alarm output, alarm display, drive output cutoff) for undervoltage can be selected. The automatic restart function (for automatically restarting a coasting motor without stopping) when the supply voltage is recovered can also be selected.

Set Value	Function Name	Operation at Power Failure	Operation at Power Recovery
0	Inactive (intermediate drive trip)	If undervoltage is detected, the drive will immediately trip and an undervoltage fault (LU) is displayed. The drive output stops and the motor will coast to a stop.	The drive operation is not automatically restarted. Input a reset command and operation command to restart.
1	Inactive (drive trip at recovery)	If undervoltage is detected, the drive output stops and the motor will immediately coast to a stop. A drive fault is not activated.	An undervoltage fault (LU) is activated at power recovery. Drive operation is not automatically restarted. Input a reset command to restart operation.
2	Inactive (drive trip after deceleration to a stop at power failure)	When the DC bus voltage reaches the operation voltage level (H15), a controlled deceleration to a stop occurs. The drive collects the inertial energy of the load to maintain the DC bus voltage and controls the motor until it stops, then an undervoltage fault (LU) is activated. The drive will automatically decrease the deceleration time if necessary. If the amount of inertial energy from the load is small, and the undervoltage level is achieved before the motor stops, the undervoltage fault is immediately activated and the motor will coast to a stop.	The drive operation is not automatically restarted. Input a reset command and operation command to restart operation.
3	Active (operation ride-through; for high-inertia loads)	When the DC bus voltage reaches the operation voltage level (H15), energy is collected from the inertia of the load to maintain the DC bus voltage and extend the ride-through time. The drive will automatically adjust the deceleration rate to maintain DC bus voltage level. If undervoltage is detected, the protective function is not activated, but drive output stops and the motor will coast to a stop.	Operation is automatically restarted. For power recovery during ride-through, the drive will accelerate directly to the original frequency. If undervoltage is detected, operation automatically restarts with the frequency selected at the time that the undervoltage was detected.
4	Active (restart with the frequency at the time of power failure)	If undervoltage is detected, the protective function is not activated. The drive output stops and the motor will coast to a stop.	Operation is automatically restarted with the frequency selected at the time of power failure.
5	Active (restart with start frequency; for low-inertia loads)	If undervoltage is detected, the protective function is not activated, but drive output stops.	Operation is automatically restarted with the frequency set by F23, "Starting frequency."

Function Codes H13 to H16 are provided to control a restart operation after momentary power failure. These functions should be understood and used. The pick-up (**speed search**) function can also be selected as a method of restarting when power is recovered after a momentary failure. (For setting details, see Function Code H09.) The pick-up function searches for the speed of the coasting motor to restart the motor without subjecting it to excessive shock.

In a high-inertia system, the reduction in motor speed is minimal even when the motor is coasting. A speed search time is required when the pick-up function is active. In such a case, the original frequency may be recovered sooner when the function is inactive and the operation is restarted with the frequency prior to the momentary power failure.

The pick-up function works in the range of 5 to 120 Hz. If the detected speed is outside this range, restart the motor using the regular restart function.

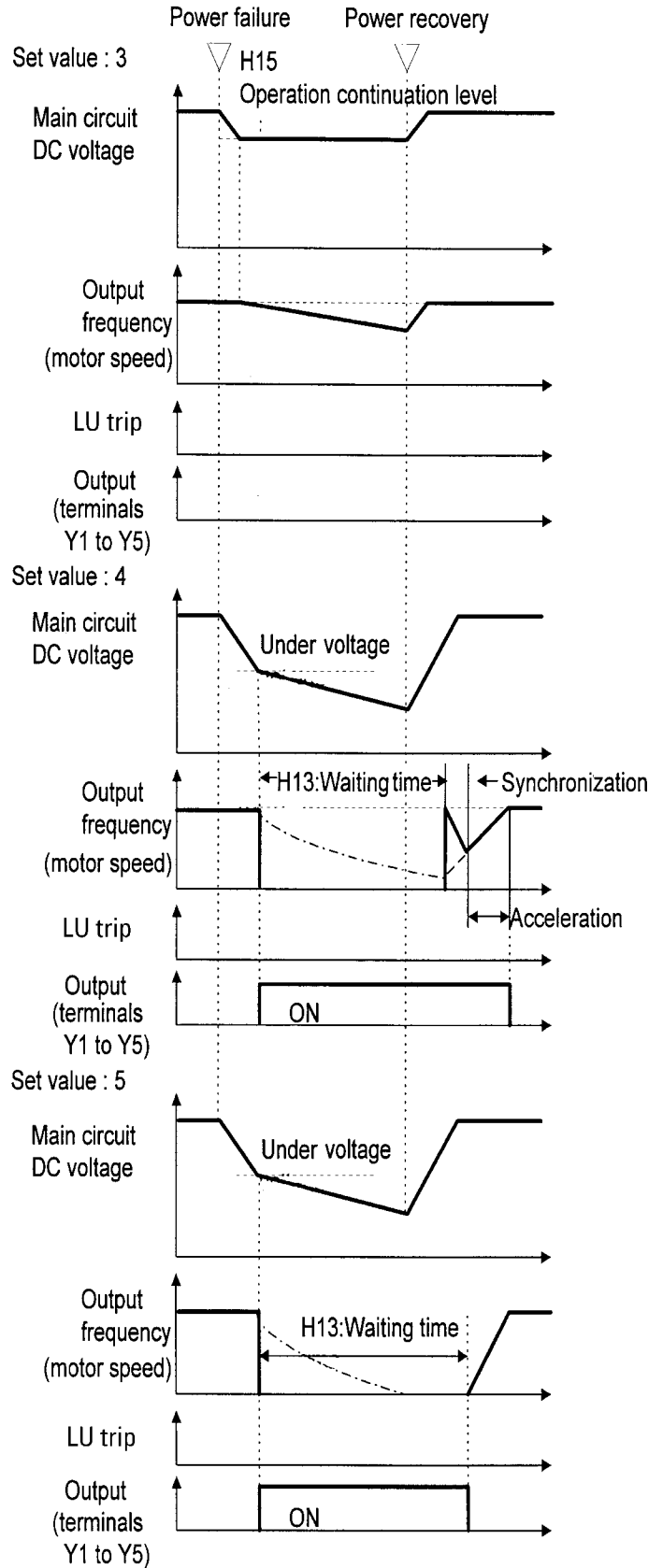
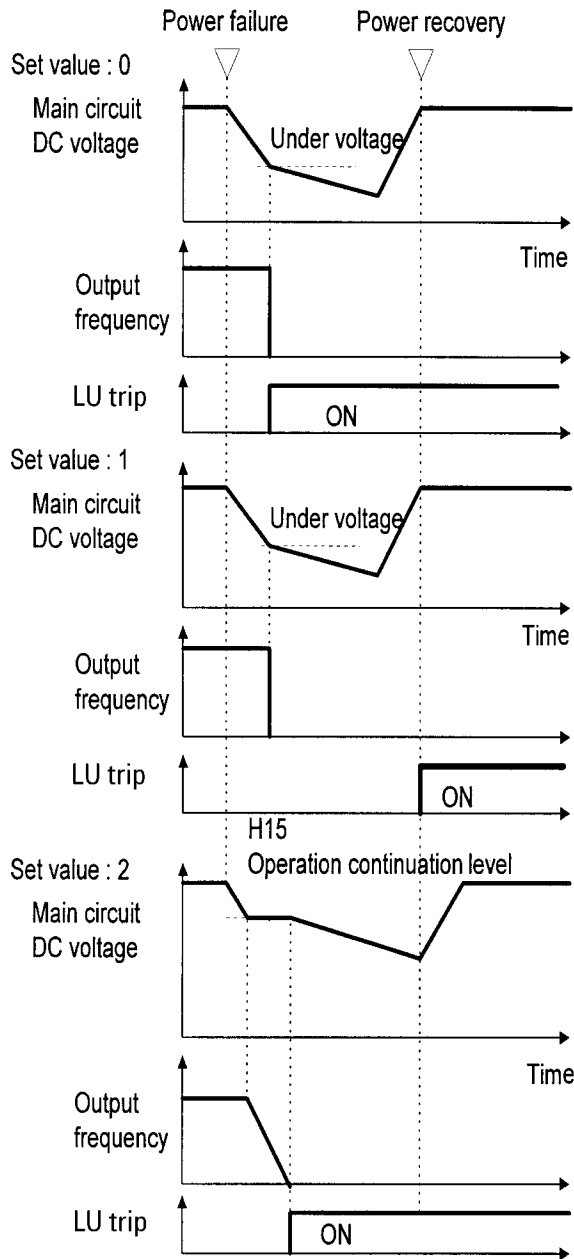

Note : Dotted-dashed lines indicate motor speed.

F15 Frequency limiter (High)

F16 Frequency limiter (Low)

F 1 5 H L I M I T E R
F 1 6 L L I M I T E R

Set values: 0 to 400 Hz

These functions are used to define the upper and lower limits of the set frequency.

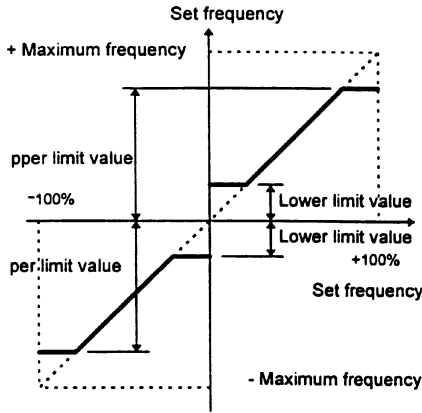

The drive output starts with the start frequency when operation begins, and stops with the stop frequency when operation ends.

If the upper limit value is less than the lower limit value, the upper limit value overrides the lower limit value.

F17 Gain

F 1 7 F R E Q G A I N

This function assigns the rate of the set frequency value to analog input.

Operation follows the figure below.

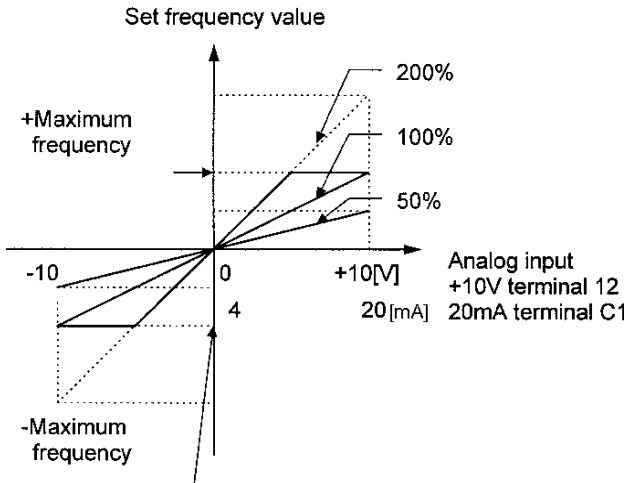

F18 Bias frequency

F 1 8 F R E Q B I A S

This function adds a bias frequency to the set frequency value from the analog input.

The operation follows the figure below. If the bias frequency is higher than the +Maximum frequency or lower than the -Maximum frequency, it is limited to the +Maximum or -Maximum frequency.

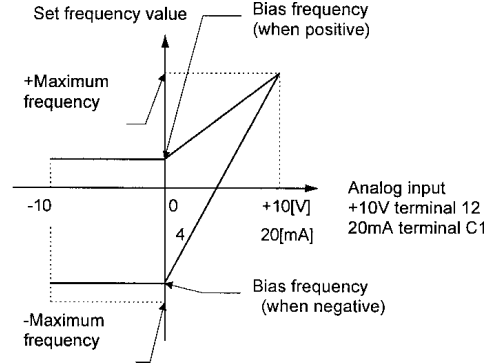

F20 DC injection brake (starting)

F21 DC injection brake (operation level)

F22 DC injection brake (time)

F 2 0 D C B R K H z

Set values: 0 to 60 Hz

Starting frequency: This function sets the frequency with which to start a DC injection brake in order to decelerate the motor to a stop.

F 2 1 D C B R K L V L

Set values: 0 to 100%

Operation level: This function sets the output current level, when a DC injection brake is applied, as a percentage of the rated output current in 1% increments.

F 2 2 D C B R K t

Set values 0.0: Inactive

0.1 to 30.0 seconds

Time: This function sets the time for a DC injection brake operation.

CAUTION

Do not use the drive brake function for mechanical holding. **Injury may occur.**

F23 Starting frequency (frequency)

F24 Start frequency (holding time)

F25 Stop frequency

F 2 3 S T A R T H z

Setting range: 0.1 to 60 Hz

The starting frequency can be set to reserve the torque at startup and can be sustained until the magnetic flux of the motor is established.

Frequency: This function sets the frequency at startup.

F 2 4 H O L D I N G t

Setting range: 0.1 to 10.0 seconds

Holding time: This function sets the holding time during which the start frequency is sustained at startup.

The holding time does not apply during switching between forward and reverse.

The holding time is not included in the acceleration time.

The holding time also applies when Pattern Operation (C21) is selected. The holding time is included in the timer value.

F 2 5 S T O P H z

Setting range: 0.1 to 6.0 Hz

This function sets the frequency at stop.

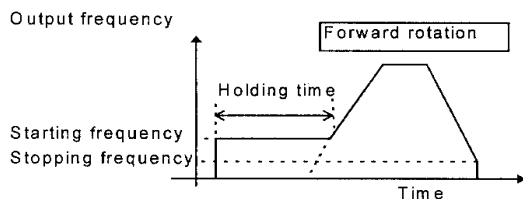

The operation will not start if the starting frequency is less than the stopping frequency or if the set frequency is less than the stopping frequency.

F26 Motor sound (carrier frequency)

F 2 6 M T R S O U N D

This function adjusts the carrier frequency to prevent resonance with the machine system, reduce motor and drive noise, and also reduce leakage current from output circuit wiring.

Drive Capacity	Setting Range
75 HP or less	0.75 to 15 kHz
100 HP or more	0.75 to 10 kHz

Carrier frequency	Low — High
Motor noise	High — Low
Output current waveform	Bad — Good
Leakage current	Small amount Large amount
Noise occurrence	Extremely low High

1. Reducing the set value adversely affects the output current waveform (i.e., higher harmonics), increases motor loss, and raises motor temperature. For example, at 0.75 kHz, reduce the motor torque by about 15%.
2. Increasing the set value increases drive loss and raises drive temperature.

F27 Motor sound (sound tone)

F 2 7 M T R T O N E

Setting range: 0, 1, 2, 3

The tone of motor noise can be altered if the carrier frequency is 7 kHz or lower. Use this function as required.

F30 FMA terminal (voltage adjustment)

F31 FMA terminal (function selection)

F 3 0 F M A V D A D J

Setting range: 0 to 200%

Monitor data (e.g., output frequency, output current) can be output to Terminal FMA as a DC voltage. The amplitude of the output can also be adjusted.

This function adjusts the voltage value of the monitor item selected in F31 when the monitor amount is 100%. A value from 0 to 200% can be set in 1% increments.

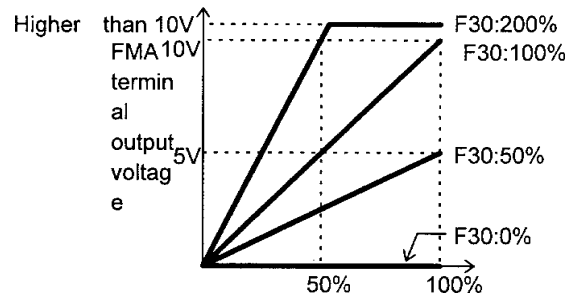

F 3 1 F M A F U N C

This function selects the monitor item to be output to Terminal FMA.

Value	Monitor Item	100% Monitor Amount
0	Output frequency 1 (before slip compensation)	Maximum output frequency
1	Output frequency 2 (after slip compensation)	Maximum output frequency
2	Output current	2x rated output current of drive
3	Output voltage	230V series: 250V 460V series: 500V
4	Output torque	2x rated motor torque
5	Load rate	2x rated load of motor
6	Output	2x rated drive output
7	PID feedback amount	Feedback amount at 100%
8	PG feedback amount (only when option is installed)	Synchronous speed at maximum frequency
9	DC link circuit voltage	230V series: 500V 460V series: 1,000V
10	Universal AO	Output from RS485 or Bus option

F33 FMP terminal (pulse rate)

F34 FMP terminal (voltage adjustment)

F35 FMP terminal (function selection)

Monitor data (e.g., output frequency, output current) can be output to Terminal FMP as pulse voltage. Monitor data can also be sent to an analog meter as average voltage.

When sending data to a digital counter or other instrument as pulse output, set the pulse rate in F33 to any value and the voltage in F34 to 0%.

When data is sent to an analog meter or other instrument as average voltage, the voltage value set in F34 determines the average voltage, and F33 is fixed at 2670 (p/s).

F 3 3 F M P P U L S E S

Set values: 300 to 6,000 p/s, in 1 p/s increments

The F33 function sets the pulse frequency of the monitor item selected in F35.

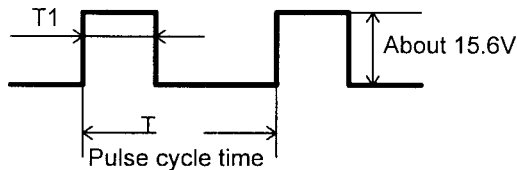

Pulse frequency (p/s) = 1/T

Duty (%) = T1/T x 100

Average voltage (V) = 15.6 x T1/T

F 3 4 F M P V O A D J

Set value 0%: The pulse frequency varies depending on the amount of the monitor item selected in F35 (maximum value is the value set in F33).

The F34 function sets the average voltage of pulse output to Terminal FMP.

1 to 200%: Pulse frequency is fixed at 2,670 p/s. The average voltage of the monitor item selected in F35, when the monitor amount is 100%, is adjusted in the range 1 - 200%, in 1% increments (pulse duty varies).

F 3 5 F M P F U N C

The F35 function selects the monitor item to be output to Terminal FMP.

The set value and monitor items are the same as those used for F31 (refer to table).

F36 30Ry operation mode

F 3 6 3 0 R Y M O D E

This function specifies whether to activate (excite) the alarm output relay (30Ry) for any fault at normal or alarm status.

Value	Operation	
0	Drive no power	30A - 30C: OFF, 30B - 30C: ON
	At normal	30A - 30C: OFF, 30B - 30C: ON
	At alarm	30A - 30C: ON, 30B - 30C: OFF
1	Drive no power	30A - 30C: OFF, 30B - 30C: ON
	At normal	30A - 30C: ON, 30B - 30C: OFF
	At alarm	30A - 30C: OFF, 30B - 30C: ON

If the set value is 1, contacts 30A and 30C are connected when the drive control voltage is established (about one second after power on).

F40 Torque limit 1 (drive)

F41 Torque limit 1 (brake)

F 4 0 D R V T R Q I
F 4 1 B R K T R Q I

The torque limit operation calculates motor torque from the output voltage, current and the primary resistance value of the motor, and controls the frequency so the calculated value does not exceed the limit. This operation enables the drive to continue operation under the limit even if a sudden change in load torque occurs.

Limits are set for driving torque and braking torque.

When this function is activated, acceleration and deceleration operation times are longer than the set values.

Function	Set Value	Operation
Torque limit (driving)	20% to 200%	The torque is limited to the set value.
	999	Torque limiting inactive
Torque limit (braking)	20% to 200%	The torque is limited to the set value.
	0	Automatically prevents OU trip due to power regeneration effect
	999	Torque limiting inactive

WARNING

When the torque limit function is selected, an operation may not match the set acceleration and deceleration time or set speed. The machine should be so designed that safety is ensured even when operation does not match the set values.

F42 Torque vector control 1

F 4 2 T R Q V E C T O R 1

To obtain the most efficient motor torque, the torque vector control calculates torque according to load, to adjust the voltage and current vectors to optimum values based on the calculated value.

Value	Operation
0	inactive
1	active

Related Functions P01 to P09

If F42 = 1 (active), the following functions are affected:

1. F09 Torque boost 1 is automatically set to 0.0 (automatic torque boosting).
2. P09 Slip compensation control is automatically activated. If set to 0.0, the amount of slip compensation for a standard 3-phase motor is applied. Otherwise, the set value is applied.

Use the torque vector control function under the following conditions:

1. There can only be one motor.
Connection of two or more motors makes accurate control difficult.
2. The function data (rated current P03, no-load current P06, %R1 P07, and %X P08) for Motor 1 must be correct.
Function P02 contains typical motor settings.
If not correct, use Auto tune (P04).
3. The rated current of the motor must not be significantly less than the rated current of the drive. A motor two sizes lower in capacity than the nominal motor indicated for the drive is the smallest that should be used.
4. To prevent leakage current and ensure accurate control,, the length of the cable between the drive and motor should not exceed 50 m.
5. If a reactor is connected between the drive and the motor and wiring impedance cannot be disregarded, use P04 Auto tuning to reset data.

If these conditions are not satisfied, set F42 = 0 (Inactive).

E: Extension Terminal Functions

E01 Terminal X1

E09 Terminal X9

E0	1	X	1	F	U	N	C		
E0	2	X	2	F	U	N	C		
E0	3	X	3	F	U	N	C		
E0	4	X	4	F	U	N	C		
E0	5	X	5	F	U	N	C		
E0	6	X	6	F	U	N	C		
E0	7	X	7	F	U	N	C		
E0	8	X	8	F	U	N	C		
E0	9	X	9	F	U	N	C		

Functions can be individually set from each of the digital input Terminals X1 to X9.

Value	Function
0,1,2,3	Multi-step frequency selection (1 to 15 steps)
4,5	Acceleration and deceleration time selection (3 steps)
6	Self-hold selection (HLD)
7	Coast-to-stop command (BX)
8	Alarm reset (RST)
9	External alarm (THR)
10	Jogging (JOG)
11	Frequency setting 2 / Frequency setting 1 (Hz2 / Hz1)
12	Motor 2 / Motor 1 (M2 / M1)
13	DC injection brake command (DCBRK)
14	Torque limit 2 / Torque limit 1 (TL2 / TL1)
15	Switching operation from line to drive (50 Hz) (SW50)
16	Switching operation from line to drive (60 Hz) (SW60)
17	UP command (UP)
18	DOWN command (DOWN)
19	Edit permission command (data change permission) (WE-KP)
20	PID control cancellation (Hz / PID)
21	Normal/Inverse switching (Terminals 12 and C1) (IVS)
22	Interlock (52-2) (IL)
23	Torque control cancellation (Hz/TRQ)
24	Link operation selection (Standard: RS485, Option: BUS) (LE)
25	Universal DI (U-DI)
26	Pick up start mode (STM)
27	SY-PG enable (PG/Hz)
29	Zero speed command (ZERO)
30	Timed alarm stop command (STOP1)
31	Timed alarm stop command with Deceleration time 4 (STOP2)
32	Pre-exciting command (EXCITE)

Note: Values which are not set in the functions from E01 to E09 are assumed to be inactive.

Multi-step frequency selection

Value 0,1, 2, 3: The frequency can be switched to a preset frequency in Function Codes C05 to C19 by switching the external digital input signal. Assign Values 0 to 3 to the target digital input terminal. The combination of input signals determines the frequency.

Combination of Input Signals				Selected Frequency	
3 (SS8)	2 (SS4)	1 (SS2)	0 (SS1)		
off	off	off	on	C05 MULTI Hz-1	Related Functions: C05-C19 Setting Range: 0.00 to - 400.00 Hz
off	off	on	off	C06 MULTI Hz-2	
off	off	on	on	C07 MULTI Hz-3	
off	on	off	off	C08 MULTI Hz-4	
off	on	off	on	C09 MULTI Hz-5	
off	on	on	off	C10 MULTI Hz-6	
off	on	on	on	C11 MULTI Hz-7	
on	off	off	off	C12 MULTI Hz-8	
on	off	off	on	C13 MULTI Hz-9	
on	off	on	off	C14 MULTI Hz-10	
on	off	on	on	C15 MULTI Hz-11	
on	on	off	off	C16 MULTI Hz-12	
on	on	off	on	C17 MULTI Hz-13	
on	on	on	off	C18 MULTI Hz-14	
on	on	on	on	C19 MULTI Hz-15	

Acceleration and Deceleration time selection

Value 4, 5: The acceleration and deceleration time can be switched to a preset time in Function Codes E10 to E15 by switching the external digital input signal. Assign Values 4 and 5 to the target digital input terminal. The combination of input signals determines the acceleration and deceleration times.

Combination of Input Signals		Selected Acceleration / Deceleration Times	
5 (RT2)	4 (RT1)		
off	off	F07 ACC TIME1 F08 DEC TIME1	Related Functions: E10-E15 Setting Range: 0.01 to 3600s
off	on	E10 ACC TIME2 E11 DEC TIME2	
on	off	E12 ACC TIME3 E13 DEC TIME3	
on	on	E14 ACC TIME4 E15 DEC TIME4	

Self-hold selection (HLD)

Value 6: This selection is used for 3-wire operation. The FWD or REV signal is self-held when HLD-CM is on, and this self-hold is cleared when HLD-CM is turned off. To use this HLD terminal function, assign 6 to the target digital input terminal.

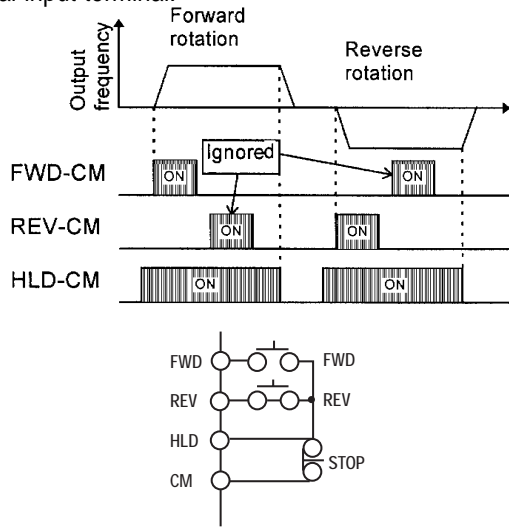

Coast-to-stop command (BX)

Value 7: When BX and CM are connected, drive output is cut off immediately, and the motor starts to coast to a stop. An alarm signal is neither output nor self-held. If BX and CM are disconnected when the operation command (FWD or REV) is on, operation begins at the start frequency. To use this BX terminal function, assign Value 7 to the target digital input terminal.

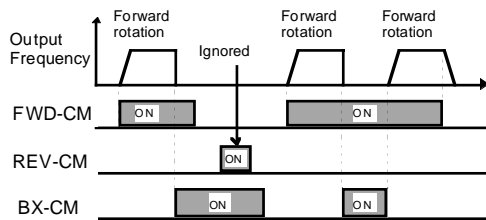

Alarm reset (RST)

Value 8: If a drive trip occurs, connecting RST to CM clears the alarm output (for any fault). Disconnecting them clears the trip indication and restarts operation. To use this RST terminal function, assign Value 8 to the target digital input terminal.

External alarm (THR)

Value 9: Disconnecting THR and CM during operation cuts off drive output (i.e., motor starts to coast to a stop) and outputs Alarm OH2, which is self-held internally and cleared by RST input. This function is used to protect an external brake resistor and other components from overheating. To use this THR terminal function, assign Value 9 to the target digital input terminal. ON input is assumed if this terminal function is not set.

Jogging (JOG)

Value 10: This function is used for jogging operation to position a workpiece. When JOG and CM are connected, the

operation is performed with the jogging frequency set in Function Code C20 while the operation command (FWD-CM or REV-CM) is on. To use this JOG terminal function, assign 10 to the target digital input terminal.

Frequency setting 2/frequency setting 1

Value 11: This function switches the frequency setting method defined by Function Codes F01 and C30 using an external digital input signal.

Input Signal	Selected Frequency Setting
11	
off	F01 FREQ CMD1
on	C30 FREQ CMD2

Motor 2/Motor 1

Value 12: This function switches motor constants using an external digital input signal.

This input is effective only when the operation command to the drive is off and operation has stopped and does not apply to the operation at 0Hz.

Input Signal	Selected Motor
12	
off	Motor 1
on	Motor 2
	Related Functions: A01-A18

DC injection brake command (DCBRK)

Value 13: This function is used for DC Brake time control by digital input including extending braking operation during stopping as well as during start up into a rotating load. When the external digital input signal is on, DC injection braking starts when the drive's output frequency drops below the frequency preset in Function Code F20 after the operation command goes off. (The operation command goes off when the STOP key is pressed during keypad panel operation or when both Terminals FWD and REV go off during terminal block operation.) The DC injection braking continues while the digital input signal is on. In this case, the longer of the following times is selected:

- The time set with Function Code F22
- The time during which the input signal is set ON

Input Signal	Selected Operation
13	
off	DC injection brake command not given
on	DC injection brake command given

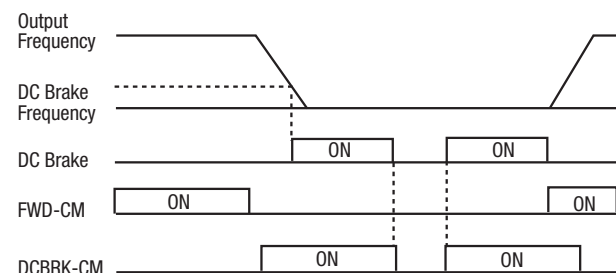

Torque limit 2/torque limit 1

Value 14: Frequency setting 2/frequency setting 1. This function switches the torque limit value set with Function Codes F40, F41, E16, and E17, using an external digital input signal.

Input Signal	Selected Torque Limit Value	
14		
off	F40 DRV TRQ1 F41 BRK TRQ1	Related Functions F40-F41, E16-E17
on	E16 DRV TRQ2 E17 DRV TRQ2	Setting Range DRV 20 to 200%, .999 BRK0, 20 to 200%, .999

Switching operation from line drive (60Hz)(SW60)/(50Hz)(SW50)

Value 15, 16: Motor operation can be switched from 60 Hz/50 Hz commercial power to drive operation without stopping the motor by switching the external digital input signal.

Input Signal	Function
16	
off → on	Drive operation to line operation (60 Hz)/(50 Hz)
on → off	Line operation to drive operation (60 Hz)/(50 Hz)

Following a momentary power failure, if the digital input signal goes off, 50 or 60 Hz (according to the input signal) is output after the restart waiting time (Function Code H13). The motor is then directed to drive operation.

UP command (UP)/DOWN command (DOWN)

Value 17, 18: When an operation command is input (on), the output frequency can be increased or decreased using an external digital input signal.

The change ranges from 0 to maximum frequency. Operation in the opposite direction of the operation command is not allowed.

Combination of Input Signals		Selected Function (when operation command is on)
18	17	
off	off	Holds the output frequency
off	on	Increases the output frequency according to the acceleration time
on	off	Decreases the output frequency according to the deceleration time
on	on	Holds the output frequency

There are the two types of UP/DOWN operations as shown below. Select the desired type by setting the frequency (F01 or C30).

Frequency setting (F01 or C30)	Initial value at power input on	Operation command reentry during deceleration
8 (UP/DOWN1)	0Hz	Operates at the frequency at reentry. Frequency FWD ON (REV) OFF
9 (UP/DOWN2)	Previous frequency	Returns to the frequency before deceleration. Frequency FWD ON (REV) OFF

Edit permission command (data change permission)(WE-KP)

Value 19: This function allows the data to be changed only when input is received from an external signal, thereby preventing function code data changes.

19	Selected Function
off	Prohibit data changes
on	Allow data changes

Note: If a terminal is assigned the Value 19, the data cannot be changed. To change data, turn the terminal on and change its setting to another number.

PID control cancellation (Hz/PID)

Value 20: The PID control can be disabled by an external digital input signal.

Input Signal	Selected Function
20	[Related Functions: H20-H25]
off	Enable PID control
on	Disable PID control

(When the PID control is disabled, the frequency is set from the keypad panel.)

Normal operation/inverse

Value 21: Analog input (Terminals 12 and C1) can be switched between normal and inverse operations using an external digital input signal.

Input Signal	Selected Function
21	[Related Function: F01]
off	Normal operation if normal operation is set and vice versa
on	Inverse operation if normal operation is set and vice versa

Interlock (52-2)

Value 22: When a contactor is installed on the output side of the drive, the contactor opens at the time of a momentary power failure. This prevents the reduction of the DC circuit voltage and may prevent the detection of a power failure and a correct restart operation after power is recovered. The restart operation, in the event of a momentary power failure, can be performed effectively with power failure information provided by an external digital input signal.

Input Signal	Function
22	
off	No momentary power failure detection by digital input
on	Momentary power failure detection by digital input

Torque control cancellation (Hz/TRQ)

Value 23: If Function Code **H18 Torque control** is set to active (Value = 1 or 2), this operation can be cancelled externally by assigning 23 to the target digital input terminal and switching between active and inactive for this input signal.

Input Signal	Selected Function
23	[Related Function: H18]
off	Torque control function active – the input voltage to Terminal 12 is the torque command value
on	Torque control function inactive - the input voltage to Terminal 12 is the frequency command value. PID feedback amount when PID control operation is selected (H20 = 1 or 2).

Link Operation selection (LE)

Value 24: Frequency and operation commands from the data communications link can be enabled or disabled by switching the external digital input signal. Select the command source in **H30-Link function** and assign 24 to the target digital input terminal to enable or disable commands in this input signal state.

Input Signal	Selected Function
24	[Related Function: H30]
off	Link command disabled
on	Link command enabled

Universal DI (U-DI)

Value 25: Assigning 25 to a digital input terminal renders the terminal a universal DI terminal. The ON/OFF state of signal input to this terminal can be checked through the RS485 and BUS option.

This input terminal is only used to check for an incoming input signal through communication and does not affect drive operation.

Pick up start mode (STM)

Value 26: The (pick-up start mode): in Function Code H09 can be enabled or disabled by switching the external digital input signal. Assign 26 to the target digital input terminal to enable or disable the function in this input signal state.

Input Signal	Selected Function
26	[Related Function: H09]
off	Start characteristic function disabled
on	Start characteristic function enabled

SY-PG enable (PG/Hz)

Value 27: This selects the closed loop control with PG (encoder) or open loop control.

Input Signal	Operation Select
27	
off	open loop control
on	close loop control

Note: PG Option Card is required for this function.

Zero speed command (zero)

Value 29: This function is used for stall torque operation with vector control at zero.

Input Signal	Selected Function
29	
off	zero speed control disabled
on	zero speed control enabled

Note: PG Option Card is required for this function.

Timed alarm stop command (STOP1)

Timed alarm stop command with deceleration time 4 (STOP2)

Value 30, 31: Disconnecting STOP1 and CM during operation, the drive decelerates and stops by a preset deceleration time (STOP1)/deceleration time 4 (STOP2) setting and then outputs Alarm Er6 which is latched internally and cleared by RST input. ON input is assumed when this terminal function is not set.

Pre-exciting command (EXCITE)

Value 32: When EXCITE transition is ON, the motor enters into a pre-exciting state during flux vector control mode. When an operation command (FWD or REV) is initiated, the motor returns from the pre-exciting state to the ordinary state.

Note: PG Option Card is required for this function.

Digital Input	Value	Factory Settings at Shipment Description
Terminal X1	0	Multi-step frequency selection (SS1)
Terminal X2	1	Multi-step frequency selection (SS2)
Terminal X3	2	Multi-step frequency selection (SS4)
Terminal X4	3	Multi-step frequency selection (SS8)
Terminal X5	4	Acceleration and deceleration selection (RT1)
Terminal X6	5	Acceleration and deceleration selection (RT2)
Terminal X7	6	Self-hold selection (HLD)
Terminal X8	7	Coast-to-stop command (BX)
Terminal X9	8	Alarm reset (RST)

- E10 Acceleration time 2
- E11 Deceleration time 2
- E12 Acceleration time 3
- E13 Deceleration time 3
- E14 Acceleration time 4
- E15 Deceleration time 4

E	1	0	A	C	C	T	I	M	E	2		
E	1	1	D	E	C	T	I	M	E	2		
E	1	2	A	C	C	T	I	M	E	3		
E	1	3	D	E	C	T	I	M	E	3		
E	1	4	A	C	C	T	I	M	E	4		
E	1	5	D	E	C	T	I	M	E	4		

Acceleration time1 (F07) and Deceleration time1 (F08), as well as three other acceleration and deceleration times, can be selected.

The operation and setting ranges are the same as those for Acceleration time1 and Deceleration time1. See explanations for F07 and F08.

For switching acceleration and deceleration times, select any two terminals (from Terminal X1 in E01 to Terminal X9 in E09) as switching signal input terminals. Set the selected terminals to 4 (acceleration and deceleration time1) and 5 (acceleration and deceleration time2) and input a signal to each terminal to switch acceleration and deceleration times. Switching is possible during acceleration, deceleration, or constant speed operation.

Example: When Terminals X2 and X3 are set to 4 and 5:

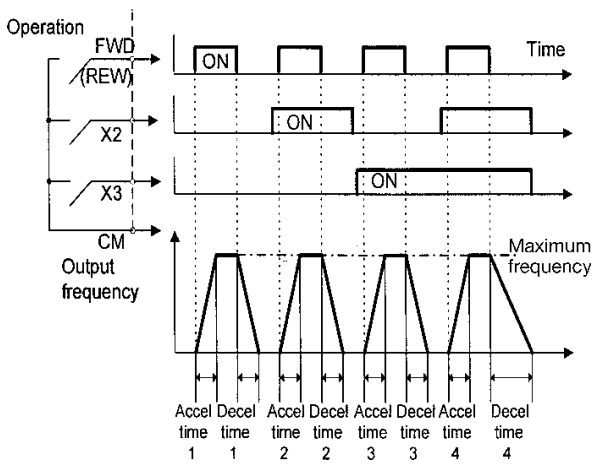

- E16 Torque limit 2 (drive)
- E17 Torque limit 2 (brake)

E	1	6	D	R	V	T	R	Q	2		
E	1	7	B	R	K	T	R	Q	2		

This function is used to switch the torque limit level set by F40 and F41, using an external control signal. Input an external signal by setting any of the digital input Terminals (X1 to X9) to 14 for Torque limit 2 / Torque limit 1 in E01 to E09.

- E20 Terminal Y1 (function selection)
- E24 Terminals Y5A and Y5C (function selection)

E	2	0	Y	1	F	U	N	C			
E	2	1	Y	2	F	U	N	C			
E	2	2	Y	3	F	U	N	C			
E	2	3	Y	4	F	U	N	C			
E	2	4	Y	5	F	U	N	C			

Some control and monitor signals can be selected and output from Terminals Y1 to Y5. Terminals Y1 to Y4 use a transistor output; Terminals Y5A and Y5C use relay contacts.

Value	Output Signal
0	Drive Running (RUN)
1	Frequency arrival (FAR)
2	Frequency detection (FDT1)
3	Stopping due to undervoltage (LV)
4	Torque polarity detection (B/D)
5	Torque limiting (TL)
6	Restart after momentary power failure (IPF)
7	Overload - early warning (OLI)
8	Keypad panel operation (KP)
9	Drive stopping (STP)
10	Ready for operation (RDY)
11	Switching between line and drive (SW88)
12	Switching between line and drive (SW52-2)
13	Switching between line and drive (SW52-1)
14	Motor 2 switching (SWM2)
15	Terminal AX function (AX)
16	Pattern operation stage change (TU)
17	Pattern operation cycle operation completed (TO)
18	Pattern operation stage number (STG1)
19	Pattern operation stage number (STG2)
20	Pattern operation stage number (STG4)
21	Alarm detail (AL1)
22	Alarm detail (AL2)
23	Alarm detail (AL4)
24	Alarm detail (AL8)
25	Cooling fan operating (FAN)
26	Retry function operating (TRY)
27	Universal DO (U-DO) *
28	Heat sink overheat - early warning (OH)
29	Synchronization completed by synchronous operation card (SY) *
30	unused
31	2nd Freq. level detection (FDT2)
32	2nd OL level early warning (OL2)
33	Terminal C1 off signal (C1OFF)

Note: For output signals marked *, refer to instruction manuals for RTU communication and the synchronous operation card.

Pattern operation cycle operation completed (T0)

Value 17: After the seven stages of a pattern operation have been completed, this function outputs a one-shot, 100 ms ON signal to report the completion of all stages.

Pattern operation stage number (STG1)(STG2)(STG4)

Value 18, 19, 20: During pattern operation, this function reports the stage (operation process) being operated.

Pattern Operation	Output Terminal		
	STG1	STG2	STG4
Stage No.			
Stage 1	on	off	off
Stage 2	off	on	off
Stage 3	on	on	off
Stage 4	off	off	on
Stage 5	on	off	on
Stage 6	off	on	on
Stage 7	on	on	on

When pattern operation is not activated (i.e., no stage has been selected), the terminals do not output a signal.

Alarm detail (AL1)(AL2)(AL4)(AL8)

Value 21, 22, 23, 24: This function reports the operating status of the drive protective function.

Alarm Detail (Drive Protective Function)	Output Terminal			
	AL1	AL2	AL4	AL8
Overcurrent, ground fault, blown fuse	on	off	off	off
Overvoltage	off	on	off	off
Undervoltage shortage, input phase failure	on	on	off	off
Motor 1 and Motor 2 overload	off	off	on	off
Drive overload	on	off	on	off
Heat sink overheating, drive overheating internally	off	on	on	off
External alarm input, braking resistor overheating	on	on	on	off
Memory error, CPU error	off	off	off	on
Keypad panel communication error, option communication error	on	off	off	on
Option error	off	on	off	on
Output wiring error	off	off	on	on
RTU communication error	on	off	on	on
Overspeed, PG disconnection	off	on	on	on

Under normal operation, terminals do not output a signal.

Cooling fan operating (FAN)

Value 25: When used with H06 Cooling fan ON/OFF control, this function outputs a signal while the cooling fan is operating.

Retry function operating (TRY)

Value 26: When H04 Retry operating is set to 1 or higher, the signal is output during the retry operation, if the drive protective function has been activated.

Universal DO(U-DO)

Value 27: Assigning a value of 27 to a transistor output terminal renders the terminal a universal DO terminal.

This function enables ON/OFF through the RS485 and BUS option.

This function serves only to turn the transistor output ON or OFF through communication and is not related to drive operation.

Heat sink overheat early warning (OH)

Value 28: This function outputs an early warning signal when the heat sink temperature (overheat detection level) is within 10°C of the overtemperature trip point.

Synchronization completed by synchronous operation card (SY)

Value 29: This is the synchronization complete signal for the synchronize operation option. See Option Instruction Book for details.

2nd Freq. level detection (FDT2)

Value 31: This function sets the 2nd Freq. level detection. See the explanation of Function Codes E36 and E37 Hysteresis width is the same as FDT1 (E32).

2nd OL level early warning (OL2)

Value 32: This function sets the 2nd overload relay warning. See the explanation of "Overload early warning (OL)," E37.

Terminal C1 off signal (C1OFF)

Value 33: This function outputs an ON signal, when the C1 current input is smaller than 2mA.

SETTINGS WHEN SHIPPED FROM THE FACTORY

Digital Output	Factory Setting at Shipment	
	Value	Description
Terminal Y1	0	Operating (RUN)
Terminal Y2	1	Frequency arrival (FAR)
Terminal Y3	2	Frequency detection (FDT)
Terminal Y4	7	Overload early warning (OL)
Terminal Y5	15	Terminal AX function (AX)

E25 Y5 Ry operation mode

E 2 5 Y 5 R Y M O D E

This function specifies whether to excite the Y5 relay at "ON signal mode" or "OFF signal mode."

Set Value	Operation
0	At "OFF signal mode" Y5A - Y5C: OFF At "ON signal mode" Y5A - Y5C: ON
1	At "OFF signal mode" Y5A - Y5C: ON At "ON signal mode" Y5A - Y5C: OFF

When the set value is 1, Contacts Y5A and Y5C are connected when the drive control voltage is established (about one second after power on).

E30 Frequency arrival (detection width)

E 3 0 F A R H Y S T R

Setting range: 0.0 to 10.0 Hz

This function adjusts the detection width when the output frequency is the same as the set operating frequency. The detection width can be adjusted from 0 to ±10Hz of the setting frequency.

When the frequency is within the detection width, an ON signal can be selected and output from Terminals [Y1] to [Y5].

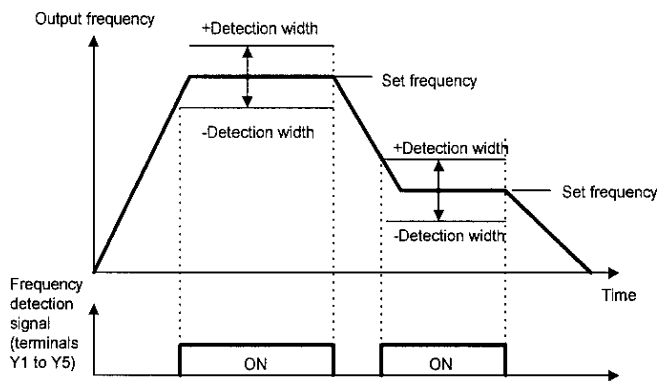

E31 Frequency detection (operation level)

E32 Frequency detection (hysteresis width)

E 3 1 F D T L E V E L
E 3 2 F D T H Y S T R

Setting range (Operation level): 0 to 400 Hz

These functions determine the operation level of the output frequency and hysteresis width for operation release. If the output frequency exceeds the set operation level, an ON signal can be output from Terminals Y1 to Y5.

(Hysteresis width): 0.0 to 30.0 Hz

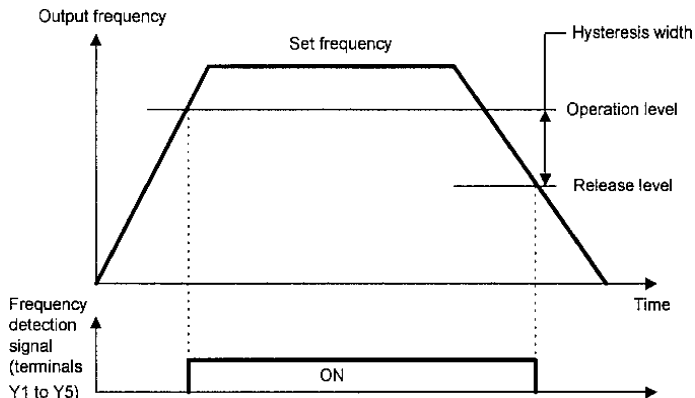

E33 Overload early warning (operation)

E 3 3 O L L E V E L

Set value 0: Electronic thermal O/L relay
1: Output current

Select one of the following two types of overload early warning: early warning by electronic thermal O/L relay or early warning by output current.

Value	Function	Description
0	Electronic thermal O/L relay	Overload early warning by electronic thermal O/L relay (with inverse time characteristics) to output current. The operation selection and thermal time constant for the inverse time characteristics are the same as those of the electronic thermal O/L relay for motor protection (F10 and F12).
1	Output current	An overload early warning is issued when output current exceeds the set current value for the set time.

E34 Overload early warning (operation level)

E 3 4 O L 1 L E V E L

Setting range: Drive rated output current x (5 to 200%)

This function determines the operation level for the electronic thermal O/L relay or output current. The operation release level is 90% of the set value.

E35 Overload early warning (operation time)

E 3 5 O L T I M E R

Setting range: 0.0 to 60.0 seconds

This function is used when E33 Overload early warning (operation selection) is set to 1.

Sets the time from when the operation level is attained until the overload early warning function is activated.

E36 Frequency detection 2 (operation level)

E 3 6 F D T 2 L E V E L

This function determines the operation (detection) level 2 of the output frequency for operation release. This function operates the same as "E31 Frequency detection 1 (operation level)." For details, see the explanation for E31.

E37 Overload early warning 2 (operation level)

E 3 7 O L 2 L E V E L

This function determines the operation level 2 of the output current. This function operates same as E33 output current and E35 settings.

E40 Display coefficient A

E41 Display coefficient B

E 4 0 C O E F A
E 4 1 C O E F B

Setting range:

Display coefficient A: -999.00 to 0.00 to +999.00

Display coefficient B: -999.00 to 0.00 to +999.00

These coefficients are conversion coefficients which are used to determine the load and line speed and the PID controller target value and feedback (process) amount displayed on the LED monitor.

Load and line speed

Use display coefficient A.

Displayed value = output frequency x (0.01 to 200.00)

Although the setting range is ±999.00, the effective range of display data is 0.01 to 200.00. Therefore, values smaller or larger than this range are limited to a minimum value of 0.01 or a maximum value of 200.00.

Target value and feedback amount of PID controller

Set the maximum value of display data in E40 Display coefficient A and the minimum value in E41 Display coefficient B.

Displayed value = (target value or feedback amount) x (Display coefficient A - B) + B

Displayed value

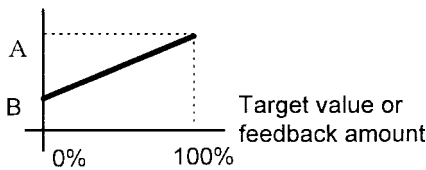

E42 Display filter

E 4 2 D I S P L A Y F L

Setting range: 0.0 to 5.0 seconds

Among data in E43 LED monitor (display selection), some data need not be displayed instantaneously when the data changes. For such data, a flicker suppression filter can be used.

Monitored items in E43 LED monitor (display selection)

Value	Display	Value	Display
3	Output current	8	Calculated torque value
4	Output voltage	9	Power consumption

E43 LED monitor (display selection)

E44 LED monitor (display at stopping)

E 4 3 L E D M N T
E 4 4 L E D M N T 2

The data during drive operation, stopping, at frequency setting, and at PID setting is displayed on the LED.

Display during running and stopping

During running, the items selected in E43 LED monitor (display selection) are displayed. In E44 LED monitor (display at stopping), specify whether to display selected items or the same items as during running.

Value of E43	E44 = 0		E44 = 1	
	At Stopping	During Running	At Stopping	During Running
0	set frequency value (Hz)	output frequency before slip compensation (Hz)		
1	set frequency value (Hz)	output frequency before slip compensation (Hz)		
2	set frequency value (Hz)			
3	output current (A)			
4	output voltage command value (V)			
5	synchronous speed set value (rpm)	synchronous speed (rpm)		
6	line speed set value (m/min)	line speed (m/min)		
7	set load speed (rpm)	load speed (rpm)		
8	calculated torque value (%)			
9	output power (kW)			
10	PID target value 1 (direct input from keypad panel)			
11	PID target value 2 (input from F02 Frequency 1)			
12	PID feedback amount			

Note: For E43 = 10 to 12, the data is displayed only if selected in H20 PID control (operation selection).

Display at frequency setting

When a set frequency is checked or changed by the keypad panel, the value shown below is displayed.

Select the display item by using E43 LED monitor (display selection). This display is not affected by E44 LED monitor (display at stopping).

Value of E43	Frequency Setting
0,1,2,3,4	set value of frequency (Hz)
5	set value of synchronous speed (rpm)
6	set value of line speed (m/min.)
7	set value of load speed (rpm)
8,9	set value of frequency (Hz)
10,11,12	set value of frequency (Hz)

Note: For E43 = 10 to 12, the data is displayed only if selected in H20 PID control (operation selection).

C: Control Functions of Frequency

C01 Jump frequency 1

C02 Jump frequency 2

C03 Jump frequency 3

C04 Jump frequency hysteresis

C01	J	U	M	P	H	z	1
C02	J	U	M	P	H	z	2
C03	J	U	M	P	H	z	3

Set value: 0 to 400Hz in 1Hz increments (min.)

C04	J	U	M	P	H	Y	S	T	R
-----	---	---	---	---	---	---	---	---	---

Set value: 0 to 30Hz in 1Hz increments (min.)

This function makes the set frequency jump so that the drive's output frequency does not match the mechanical resonance point of the load.

Up to three jump points can be set.

This function is ineffective if Jump Frequencies 1 to 3 are set to 0Hz.

A jump does not occur during acceleration or deceleration.

If a jump frequency setting range overlaps another range, both ranges are added to determine the actual jump area.

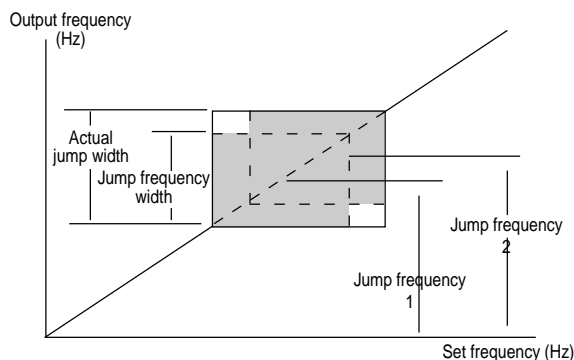
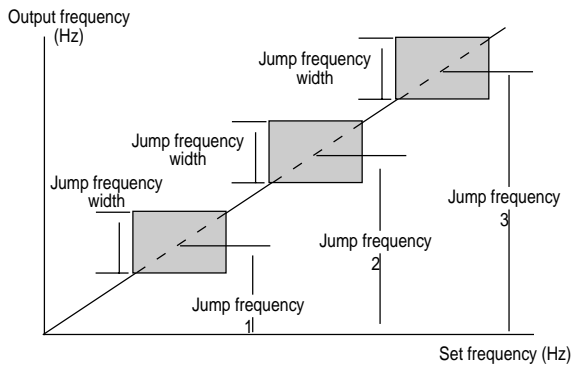

C05-C19 Multi-step frequency 1 to 15

C05	M	U	L	T	I	H	z	Đ	1
C06	M	U	L	T	I	H	z	Đ	2
C07	M	U	L	T	I	H	z	Đ	3
C08	M	U	L	T	I	H	z	Đ	4
C09	M	U	L	T	I	H	z	Đ	5
C10	M	U	L	T	I	H	z	Đ	6
C11	M	U	L	T	I	H	z	Đ	7
C12	M	U	L	T	I	H	z	Đ	8
C13	M	U	L	T	I	H	z	Đ	9
C14	M	U	L	T	I	H	z	1	0
C15	M	U	L	T	I	H	z	1	1
C16	M	U	L	T	I	H	z	1	2
C17	M	U	L	T	I	H	z	1	3
C18	M	U	L	T	I	H	z	1	4
C19	M	U	L	T	I	H	z	1	5

Set value: 0 to 400Hz In 0.01Hz increments (min.)

Multistep frequencies 1 to 15 can be switched by turning Terminal Functions SS1, SS2, SS4, and SS8 on and off. (See E01 to E09 for terminal function definitions.)

OFF is the default value for any undefined SS1, SS2, SS4, and SS8 terminals.

Related functions: E01 to E09 (Set value: 0 to 3)

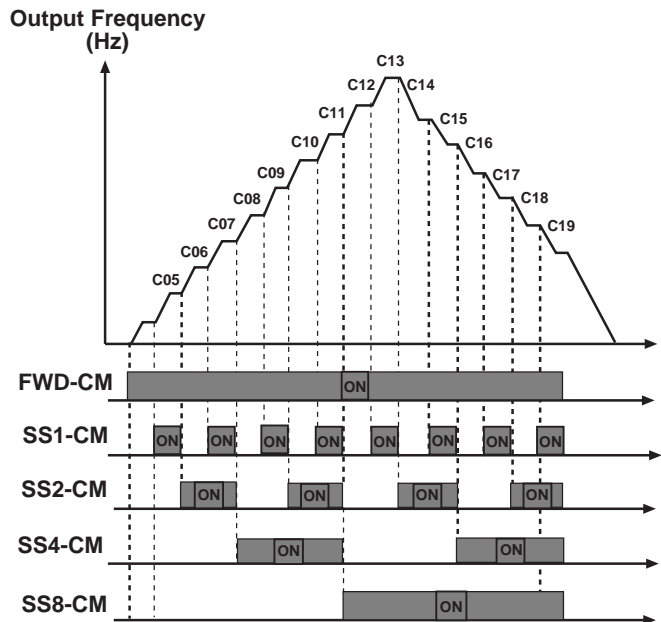

C20 Jog frequency

C 2 0 J O G H z

Setting range: 0.00 to 400.00Hz

This function sets a frequency for the motor jogging operation, which is different from the normal operation.

The jogging frequency is used for operation when the jogging mode signal is received from the keypad panel or control terminal. For details, see the explanations of E01 Terminal X1 to E09 Terminal X9.

C21 Pattern operation (operation selection)

C 2 1 P A T T E R N

Pattern operation is an automatic operation according to a preset operation time, direction of rotation, acceleration and deceleration time, and frequency.

When using this function, set **F01 Frequency setting** to 10 (pattern operation).

[Related Functions: F01, C30 = 10]

The following operation patterns can be selected.

Value	Operation Pattern
0	Perform a pattern operation cycle, then stop operation.
1	Perform pattern operation repeatedly. Operation is stopped by the STOP operation.
2	Perform a pattern operation cycle, then continue operation at the last set frequency.

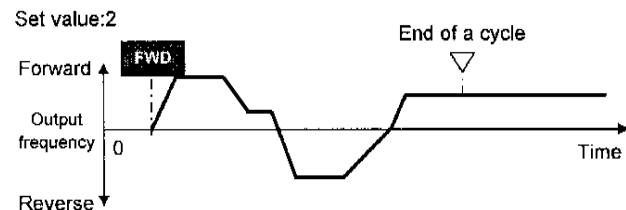
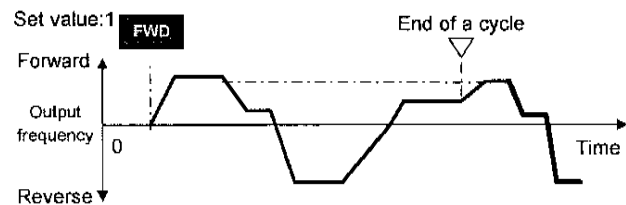
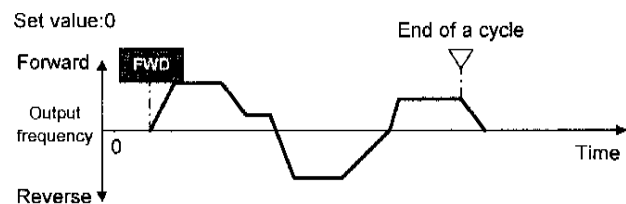

C22-C28 Pattern operation (stage 1 to 7)

C 2 2 S T A G E 1
C 2 3 S T A G E 2
C 2 4 S T A G E 3
C 2 5 S T A G E 4
C 2 6 S T A G E 5
C 2 7 S T A G E 6
C 2 8 S T A G E 7

Seven stages are operated in order of function codes, according to the values set in C22 Pattern operation (stage 1) to C28 Pattern operation (stage 7). Each function sets the operation time and the direction of rotation for each stage and assigns values to acceleration and deceleration time.

Set or Assign Item	Value Range
Operation time	0. 00 to 6000 seconds
Rotation direction	F: Forward (counterclockwise) R: Reverse (clockwise)
Acceleration and deceleration time	1: Acceleration time 1 (F07) Deceleration time 1 (F08) 2: Acceleration time 2 (E10) Deceleration time 2 (E11) 3: Acceleration time 3 (E12) Deceleration time 3 (E13) 4: Acceleration time 4 (E14) Deceleration time 4 (E15)

Note: The operation time is represented by the three most significant digits, hence, can be set with only three high-order digits.

Setting example

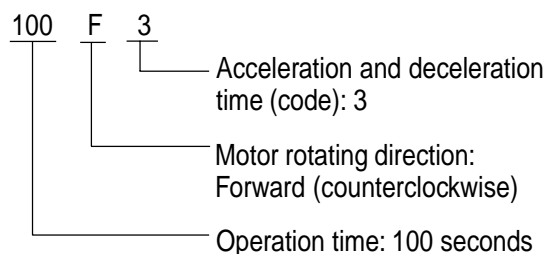

Set the operation time to 0.00 for any unused stages, which are skipped during operation.

In regard to the set frequency value, the multi-step frequency function is assigned according to the table below. Seven frequencies can be set for C05 Multi-step frequency 1 to C11 Multi-step frequency 7.

Stage No.	Operation Frequency
Stage 1	Multi-step frequency 1 (C05)
Stage 2	Multi-step frequency 2 (C06)
Stage 3	Multi-step frequency 3 (C07)
Stage 4	Multi-step frequency 4 (C08)
Stage 5	Multi-step frequency 5 (C09)
Stage 6	Multi-step frequency 6 (C10)
Stage 7	Multi-step frequency 7 (C11)

Pattern operation example

Function Value / Operation Frequency

C21	1	Selects Function
C22 (stage 1)	60.0F2	Multi-step frequency 1 (C05)
C23 (stage 2)	100F1	Multi-step frequency 2 (C06)
C24 (stage 3)	65.5R4	Multi-step frequency 3 (C07)
C25 (stage 4)	55.0R3	Multi-step frequency 4 (C08)
C26 (stage 5)	50.0F2	Multi-step frequency 5 (C09)
C27 (stage 6)	72.0F4	Multi-step frequency 6 (C10)
C28 (stage 7)	35.0F2	Multi-step frequency 7 (C11)

The following diagram shows this operation.

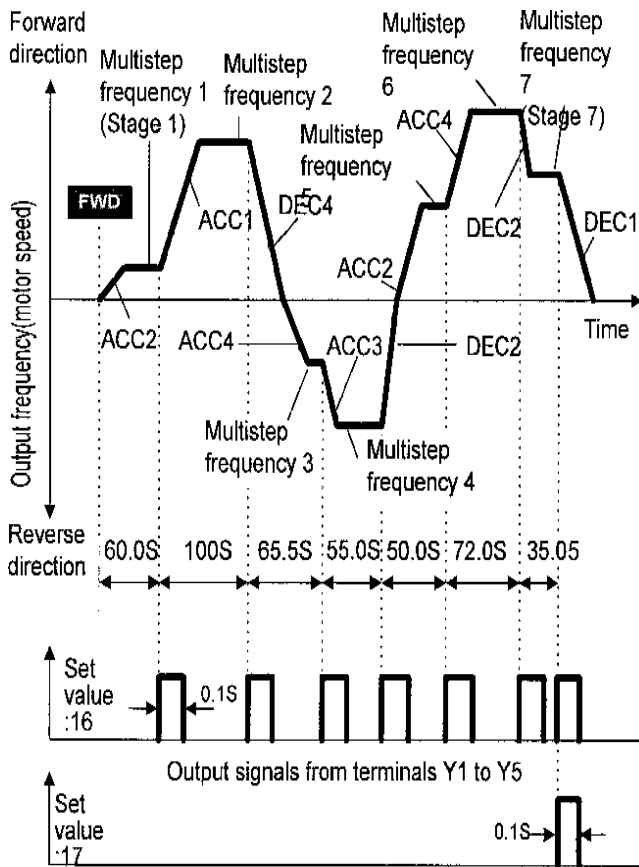

Running and stopping are controlled by pressing the STOP or FWD keys or by opening and closing the control terminals.

When using the keypad panel, the FWD key starts operation. The STOP key pauses stage advance. Pressing the FWD key again will restart operation from the stop point according to the stages. If an alarm stop occurs, press the RESET key to release the drive protective function, then press the FWD key to restart stage advance.

If operation is to restart from the first stage, **C22 Pattern operation (stage 1)**, enter a STOP command and press the RESET key.

If an alarm stop occurs, press the RESET key to release the protective function, then press the RESET key again.

Notes:

1. The direction of rotation cannot be reversed by a command issued from the REV key on the keypad panel or Terminal REV. Any reverse rotation commands entered will be canceled. Select forward or reverse rotation by the data in each stage. If the control terminals are used for operation, the self-hold function will not work. Select an alternate type switch when using control terminals.
2. At the end of a cycle, the motor decelerates to stop according to the value set in F08 Deceleration time 1.

C30 Frequency setting 2

C 3 0 F R E Q C M D 2

For the setting method, see the explanation for F01.

Note: Settings 2, 3, and 7 are inactive. (C1 signals)

This function determines the frequency setting method.

C31 Analog input bias adjustment

The setting range is -100.0 to +100.0% (in 0.1% increments) of the maximum output frequency.

C32 Analog input gain adjustment

The gain adjustment range is 0.0 to 200%.

C 3 1 B I A S
C 3 2 G A I N

These functions set the gain and bias for analog input Terminals 12 and C1, in conjunction with Functions F17 (freq. gain) and F18 (freq. bias).

Example:

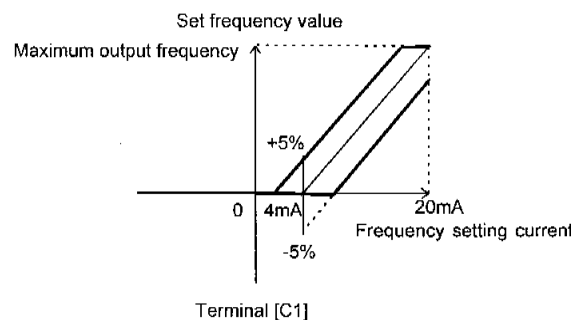
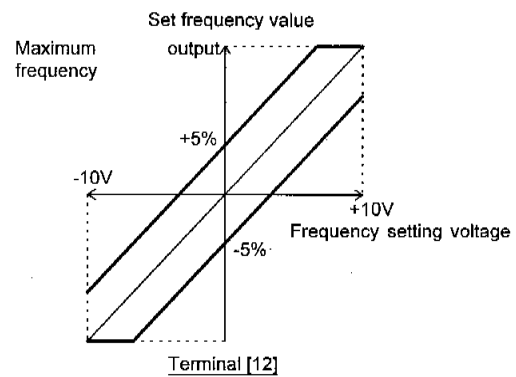

C33 Analog setting signal

C 3 3 R E F F I L T E R

Setting range: 0.00 to 5.00 seconds

Analog signals input from Terminals 12, V2 or C1 may contain noise which renders the control unstable. This function adjusts the time constant of the input filter to remove the effects of noise.

A value that is set too large delays control response although stabilizing the control. A value that is set too small speeds up control response but renders the control unstable.

If the optimum value is not known, adjust the setting if the control is unstable or response is delayed.

Note:

The set value is commonly applied to Terminals 12, V2 and C1. For input of PID feedback, the PID control feedback filter (H25) is used.

Motor 1 (P: Motor Parameters)

P01 Number of motor 1 poles

P 0 1 M 1 P O L E S

Set value: 2, 4, 6, 8, 10, 12, 14

This function sets the number of poles in Motor 1. If this setting is not made, an incorrect motor speed (synchronous speed) is displayed on the LED.

P02 Motor 1 (capacity)

P 0 2 M 1 D C A P

Set values for models with nominal motor capacity of 30HP or less: 0.01 to 60HP

Set values for models with nominal motor capacity of 40HP or more: 0.01 to 800HP

The nominal motor capacity is set at the factory. This setting should only be changed when driving a motor with a different capacity.

Set the nominal motor capacity listed in 9-1 Standard Specifications. A value in the range from two ratings lower to one rating higher than the nominal motor capacity can be set. If a value outside this range is set, accurate control cannot be guaranteed. If a value between two nominal motor capacities is set, data for the lower capacity is automatically stored for related function data.

If this function setting is changed, the following related functions are automatically set to data values for a 3-phase standard motor.

- P03 Motor 1 (rated current)
- P06 Motor 1 (no-load current)
- P07 Motor 1 (% R1)
- P08 Motor 1 (% X1)

Note:

The values for a 3-phase standard motor are 230V, 60Hz, 4 poles for the 230V series; 460V, 60Hz, 4 poles for the 460V series.

P03 Motor 1 (rated current)

P 0 3 M 1 D L R

Set value: 0.00 to 2,000 A

This function sets the rated current value for Motor 1.

P04 Motor 1 (Tuning)

P 0 4 M 1 T U N 1

This function measures and automatically stores motor data.

Value	Operation
0	Inactive
1	Measures the motor's primary resistance (%R1) and base frequency leakage reactance (%X) when the motor is stopping and automatically stores both values in P07 and P08.
2	Measures the motor's primary resistance (%R1) and base frequency leakage reactance (%X) when the motor is stopping, measures the no-load current (I _o) when the motor is running, and automatically stores these values in P06, P07, and P08.

Perform auto tuning if the previously stored data in P06 No-load current, P07 %R1, and P08 %X differs from the actual motor data. Some typical examples are listed below. Auto tuning improves control and calculation accuracy.

When a motor other than a standard 3-phase motor is used, and accurate data is required for close control.

When output-side impedance cannot be ignored, e.g., when the cable between the drive and the motor is too long or when a reactor is connected.

When %R1 or %X is unknown, e.g., when a non-standard or special motor is used.

Tuning Procedure

1. Adjust the voltage and frequency according to motor data. Adjust Functions F03 Maximum output frequency, F04 Base frequency, F05 Rated voltage, and F06 Maximum output voltage.
2. First enter motor constants that cannot be tuned. Set Functions P02 Capacity, P03 Rated current, and P06 No-load current (no-load current setting is not required if P04=2).
3. When tuning the no-load current, beware of motor rotation.
4. Set Function P04 Auto tuning = 1 (motor stop) or 2 (motor rotation). Press the FUNC/DATA key to store the set value and press the FWD key or REV key. Tuning will start.
5. Tuning may take several seconds. If P04=2, the motor accelerates up to half the base frequency according to acceleration time, is tuned for the no-load current, and decelerates according to the deceleration time. The total tuning time varies depending on the settings for acceleration and deceleration time.
6. Press the STOP key, and the procedure will end.

Note: Use Function A13 Motor 2 (auto tuning) to tune Motor 2. In this case, the set values described in (1) and (2) above are for functions A01, etc. corresponding to Motor 2.

WARNING

If the auto tuning value is set to 2, the motor rotates at a maximum of half the base frequency. Beware of motor rotation, as injury may occur.

P05 Motor 1 (On-line Tuning)

P 0 5 M 1 **T U N 2**

Long-time operation affects motor temperature and motor speed. On-line tuning minimizes speed changes related to these temperature changes.

Value	Operation
0	Inactive
1	Active

P06 Motor 1 (no-load current)

P 0 6 M 1 **Δ I O**

Set value: 0.00 to 2,000 Amps

This function sets the no-load current (exciting current) for Motor 1.

P07 Motor 1 (%R1 setting)

P08 Motor 1 (%X setting)

P 0 7 M 1 **% R 1**
P 0 8 M 1 **% X**

These functions are used to set data if using a motor other than a standard 3-phase motor and when the motor constant and the impedance between the drive and motor are known.

Calculate %R1 using the following formula:

$$\%R1 = \frac{R1 + \text{CableR}}{V / (\sqrt{3} \cdot I)} \times 100 [\%]$$

R1: Primary coil resistance value of the motor [W]

Cable R: Output-side cable resistance value [W]

V: Rated voltage [V] I: Rated current [A]

Rated current

$$\%X = \frac{X1 + X2 \cdot XM / (X2 + XM) + \text{Cable X}}{V / (\sqrt{3} \cdot I)} \times 100 [\%]$$

X1: Primary leakage reactance of the motor [W]

X2: Secondary leakage reactance (converted to a primary value) of the motor [W]

XM: Exciting reactance of the motor [W]

Cable X: Output-side cable reactance [W]

V: Rated voltage [V]

I: Rated current [A]

Notes:

For reactance, use a value from the data stored in F04 Base frequency 1.

When connecting a reactor or filter to the output circuit, add its value. Use value 0 for cable values that can be ignored.

P09 Slip compensation control

P 0 9 S L I P **C O M P 1**

Set value: 0.00 to 15.00 Hz

Changes in load torque affect motor slippage, thus causing variations in motor speed. The slip compensation control adds a frequency, proportional to motor torque, to the drive output frequency. This will minimize variations in motor speed due to changes in torque.

Calculate the amount of slip compensation using the following formula:

$$= \text{Base frequency} \times \frac{\text{Slippage [r/min.]}}{\text{Synchronous speed [r/min.]}} \text{ [Hz]}$$

Slippage = Synchronous speed - Rated speed

H: High Performance function

H03 Data initializing

H 0 3 D A T A I N I T

Set value 0: Disabled
 1: Initializes data

This function returns all function data changed by the customer to the original factory settings (initialization).

To perform initialization, press the STOP and ^ keys together to set H03=1, then press the FUNC/DATA key. The values for all functions are initialized. The set value in H03 automatically returns to 0 following the end of initialization.

H04 Auto-reset (Times)

H05 Auto-reset (Reset interval)

H 0 4 A U T O R E S E T

H 0 5 R E S E T I N T

Set the protective function release count and waiting time from its startup to release.

Setting range
 (Count) : 0, 1 to 10
 (Waiting time) : 2 to 20 seconds

When a drive protective function which invokes the retry operation is activated, these functions release operation of the protective function and restarts operation without issuing an alarm or terminating output.

To disable the retry function, set H04 Retry (count) = 0.

Drive protective functions that can invoke the retry function:

OC1, OC2, OC3: Overcurrent	dBH: braking resistor overheating
OV1, OV2, OV3: Overvoltage	OL1: Motor 1 overload
OH1: Heat sink overheating	OL2: Motor 2 overload
OH3: Drive overheating internally	OLU: Drive overload

If the value of H04 Retry (count) is set from 1 to 10, a drive run command is immediately entered following the wait time set in H05 Retry (wait time) and the startup of the retry operation. If the cause of the alarm has been removed at this time, the drive starts without switching to alarm mode. If the cause of the alarm still remains, the protective function is reactivated according to the wait time set in H05 Retry (waiting time). This operation is repeated until the cause of the alarm is removed. The restart operation switches to alarm mode when the retry count exceeds the value set in H04 Retry (count). The operation of the retry function can be monitored from Terminals Y1 to Y5.

WARNING

When the retry function is selected, operation will automatically restart, depending on the cause of the stop. (The machine should be designed to ensure safety during a restart.) When the retry function is selected, special start software (F02 set 3 or 4) does not work.

When retry succeeded

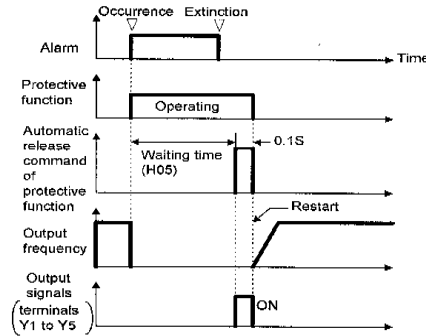

retry failed

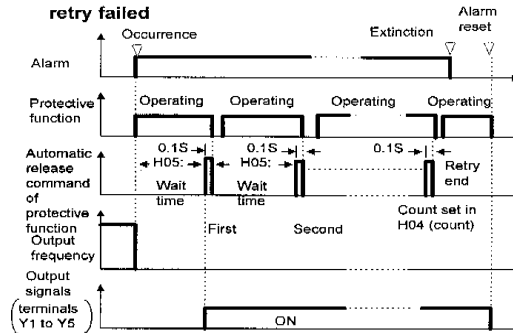

H06 Fan stop operation

H 0 6 F A N S T O P

Set value 0: ON/OFF control disabled
 1: ON/OFF control enabled

This function specifies whether ON/OFF control for the cooling fan is automatic. While power is applied to the drive, the automatic fan control detects the temperature of the heat sink and turns the fan on or off. When this control is not selected, the cooling fan rotates continuously.

The cooling fan operating status can be monitored from Terminals Y1 to Y5.

H07 ACC/DEC (Mode select) pattern

H 0 7 A C C P T N

Set value 0: Inactive (linear acceleration and deceleration)
 1: S-shape acceleration and deceleration (mild)
 2: S-shape acceleration and deceleration (sharp)
 3: Curvilinear acceleration and deceleration

This function selects the acceleration and deceleration pattern.

S-shape Acceleration and Deceleration

This pattern reduces shock by mitigating output frequency changes at the beginning and end of acceleration and deceleration.

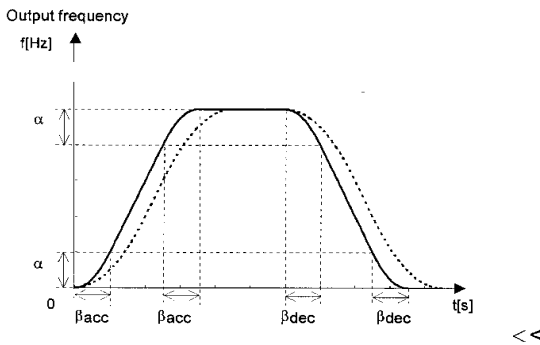

Pattern Constants>

	When 1 is selected in H07 (mid S-shape pattern)	When 2 is selected in H07 (mid S-shape pattern)
Range of S-shaped	0.05 x maximum output frequency (Hz)	0.10 x maximum output frequency (Hz)
Time for S-shaped at acceleration	0.10 x acceleration time(s)	0.20 x acceleration time(s) *
Time for S-shaped at deceleration	0.10 x deceleration(s)	0.20 x deceleration(s)

When acceleration and deceleration times are very long or short, acceleration and deceleration are almost linear.

Curvilinear Acceleration and Deceleration

This function is used to minimize motor acceleration and deceleration times in the range that includes a constant output range.

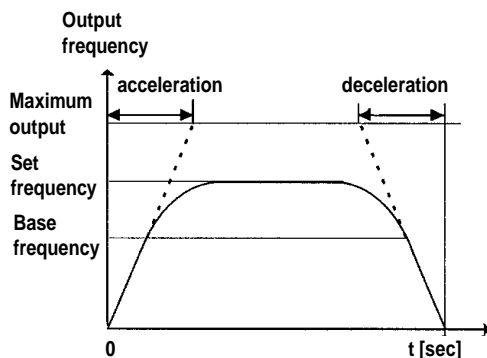

H08 Rev. phase sequence lock

H08REV LOCK

Set value 0: Inactive
1: Active

If accidental reversing could result in a malfunction, this function can be set to prevent reversal.

This function prevents a reversing operation resulting from a connection between the REV and CM terminals, inadvertent activation of the REV key, or negative analog input from Terminals 12 or V1.

H09 Start mode

H09START MODE

Setting range: 0, 1, 2

This function smoothly catches a spinning motor which is coasting after a momentary power failure or after the motor has been subject to external force, without stopping the motor, i.e., windmilling fan.

At startup, this function detects the motor speed and outputs the corresponding frequency, thereby enabling a shock-free motor startup. The normal startup method is used if the coasting speed of the motor is 120Hz or more as a drive frequency and if the value of F03 Maximum frequency exceeds the value of F15 Frequency limiter (upper limit).

Value	Normal startup	Restart after a momentary power failure	Line-to-drive switching
0	Inactive	Inactive	Inactive
1	Inactive	Active	Active
2	Active	Active	Active

Explanation

1. This function is effective if F14 Restart after momentary power failure (operation selection) is set to 3, 4, or 5. This function is also effective when operation is switched from the line to the drive. The motor is started with the same frequency as the current coasting speed (speed search).
2. In addition to restarting following a momentary power failure and switching between the line and the drive, this function detects the coasting speed of the motor and starts the motor at the same frequency as all startups (including when an ON operation command is entered).

By assigning 26 (start characteristics selection) to Terminals X1 to X9, this function can be externally selected as the normal startup method whenever an ON operation command is entered.

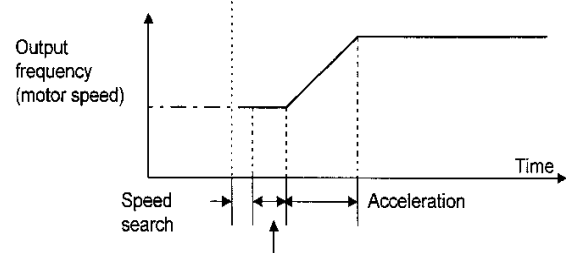
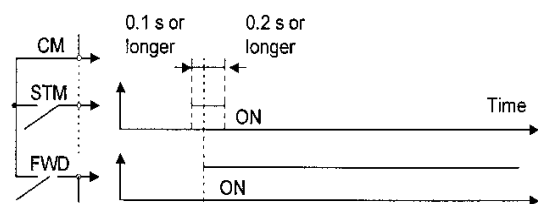

Note: The dotted-dashed line indicates motor speed.

H10 Energy-saving operation

H 1 0 E N E R G Y S A V

Set value 0: Inactive 1: Active

With constant-speed operation at light loads (fixed output frequency), this function automatically reduces the output voltage while minimizing the product of voltage and current (power).

[Exception: If F09 Torque boost 1 = 0.0]

Notes:

Use this function for variable torque loads (e.g., fans, pumps). If used for a constant torque load or rapidly changing load, this function causes a delay in control response.

The energy-saving operation automatically stops during acceleration and deceleration or when the torque limiting function is activated.

H11 DEC mode

H 1 1 D E C M O D E

Set value 0: Deceleration-to-stop based on data set with H07 Non-linear acceleration and deceleration
1: Coast-to-stop

This function determines the drive stopping method when a STOP command is entered.

Note:

This function is effective only when a STOP command is entered and, therefore, is ineffective if the motor is stopped by lowering the set frequency.

H12 Instantaneous overcurrent limiting

H 1 2 I N S T C L

Set value 0: Inactive 1: Active

An overcurrent trip generally occurs when current flows above the drive protective level, following a rapid change in motor load. The instantaneous overcurrent limiting function controls drive output and prohibits the flow of a current exceeding the protective level, even if the load changes.

Since the operation level of the instantaneous overcurrent limiting function cannot be adjusted, the torque limiting function must be used.

Motor generation torque may be reduced when instantaneous overcurrent limiting is applied. Set this function to be inactive for equipment such as elevators, which are adversely affected by reduced motor generation torque, in which case an overcurrent trip occurs when the current flow exceeds the drive protective level. A mechanical brake should be used to ensure safety.

H13 Auto-restart (Restart time)

H 1 3 R E S T A R T T

Setting range: 0.1 to 10.0 seconds

Instantaneous switching to another power line (when the power of an operating motor is cut off or power failure occurs) creates a large phase difference between the line voltage and the voltage remaining in the motor, which may cause electrical or mechanical failure. To rapidly switch power lines, store the remaining voltage attenuation time to wait for the voltage remaining in the motor to attenuate. This function operates at restart after a momentary power failure.

If the momentary power failure time is shorter than the wait time value, a restart occurs following the wait time. If the power failure time is longer than the wait time value, a restart occurs when the drive is ready to operate (after about 0.2 to 0.5 second).

H14 Auto-restart (freq. fall rate)

H 1 4 F A L L R A T E

Setting range: 0.00, 0.01 to 100.00 Hz/s

If H14 = 0.00, the frequency is reduced according to the set deceleration time.

This function determines the reduction rate of the output frequency for synchronizing the drive output frequency with the motor speed. This function is also used to reduce the frequency and thereby prevent stalling under a heavy load during normal operation.

Note:

A frequency reduction rate that is set too large may temporarily increase the regeneration energy from the load and invoke the overvoltage protective function. Conversely, a rate that is too small extends the operation time of the current limiting function and may invoke the drive overload protective function.

H15 Auto-restart (holding DC voltage)

H 1 5 H O L D V

Setting range 230V series: 200 to 300V
460V series: 400 to 600V

This function is used when **F14 Restart after momentary power failure (operation selection)** is set to 2 (deceleration-to-stop at power failure) or 3 (operation continuation). Either function starts a control operation if the main circuit DC voltage drops below the set operation continuation level.

If power supply voltage to the drive is high, control can be stabilized even under an excessive load by raising the operation continuation level. However, if the level is too high, this function activates during normal operation and causes unexpected motion. Please contact Boston Gear before changing the factory default value.

H16 Auto-restart (OPR command selfhold time)

H 1 6 S E L F H O L D T

Setting range: 0.0 to 30.0 seconds, 999

Since the power to an external operation circuit (relay sequence) and the main power to the drive is generally cut off at a power failure, the operation command issued to the drive is also cut off. This function sets the time an operation command is to be held in the drive. If a power failure lasts beyond the self-hold time, power-off is assumed, automatic restart mode is released, and the drive starts operation at normal mode when power is applied again. (This time can be considered to be the allowable power failure time.)

If H16 = 999, an operation command will be held until control power in the drive is established or until the main circuit DC voltage is about 0.

H18 Torque control

H 1 8 T R Q C T R L

This function controls motor torque according to a command value.

Note: PG Option Card is required for this function

Value	Operation [Related Functions: E01 – E09 = 23]
0	Inactive (operation by frequency command)
1	Torque control active A 0 to +10V analog voltage input to Terminal 12 and the direction of rotation (FWD or REV) are used for the torque command value. 0 is used for 0 to -10V.
2	Torque control active A -10 to +10V analog voltage input to Terminal 12 and the direction of rotation (FWD or REV) are used for the torque command value.

Torque control block diagram

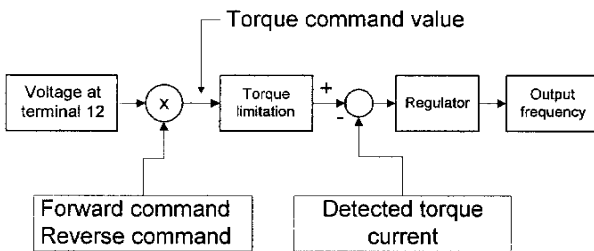

The torque command value is +200% when the voltage at Terminal 12 is +10V and is -200% when the voltage is -10V.

Under torque control, the torque command value and motor load determine the speed and direction of rotation.

When the torque is controlled, the upper frequency limit refers to the lowest value among the maximum frequency, the frequency limiter (upper limiter), and 120Hz. Maintain the frequency at a minimum of 1/10 of the base frequency because torque control performance deteriorates at lower frequencies.

If the operation command goes off during a torque control operation, the operation is switched to speed control and the motor decelerates-to-stop. At this time, the torque control function will not operate.

H19 Active drive

H 1 9 A U T R E D

Set value 0: Inactive
1: Active

This function automatically extends accelerating time by 60 seconds or longer to prevent a drive trip resulting from a temperature rise in the drive due to overcurrent.

(If the Active drive function is activated, the acceleration time will be three times the selected time.)

H20 PID control (mode select)

H 2 0 P I D M O D E

Set value 0: No operation
1: Normal operation
2: Inverse operation

PID control detects the amount of feedback from a sensor and compares it with the target value (e.g., reference temperature). If the values differ, this function produces an output to eliminate the deviation. In other words, this control matches the feedback amount with the target value.

This function can be used for flow control, pressure control, temperature control, and other process controls.

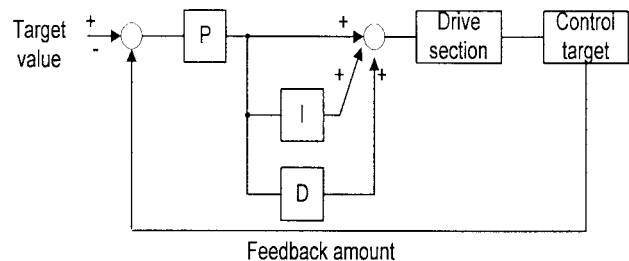

Forward or reverse operations can be selected for PID controller output. This enables motor speed to be faster or slower according to PID controller output.

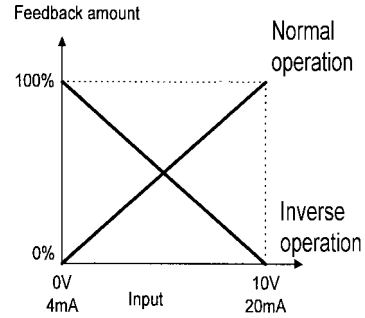
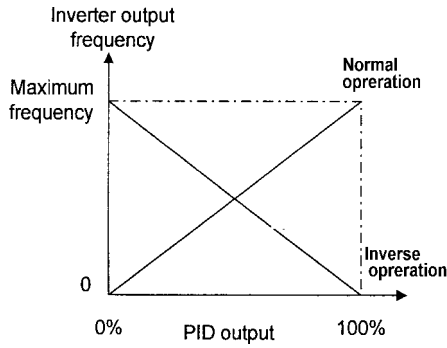

The target value can be entered using F01, Frequency setting 1, or directly from the keypad panel.

For entry from F01, Frequency setting 1, input a signal to the selected terminal. For direct entry from the keypad panel, turn on keypad operation. Select any of the digital Terminals X1 (E01) to X9 (E09) and assign a value of 11 (frequency setting switching).

Note: For the target value and feedback amount, the process amount can be displayed according to the values set in E40 Display coefficient A, and E41 Display coefficient B.

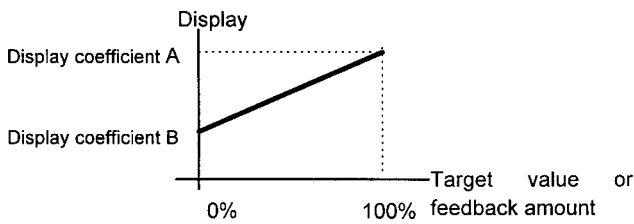

Only positive values can be input for this feedback amount of PID control. Negative values (e.g., 0 to -10V, -10 to 0V) cannot be input, thereby the function cannot be used for a reverse operation by an analog signal.

Feedback signal setting (H21) must be different from the type of setpoint value.

H21 PID control (feedback signal)

H 2 1 F B S I G N A L

This function selects the terminal, direction of operation, and feedback input. Select a value from the table below according to sensor specifications.

Value	Description
0	Terminal 12, forward operation, 0 to 10V voltage input
1	Terminal C1, forward operation, 4 to 20mA current input
2	Terminal 12, reverse operation, 10 to 0V voltage input
3	Terminal C1, reverse operation, 20 to 4mA current input

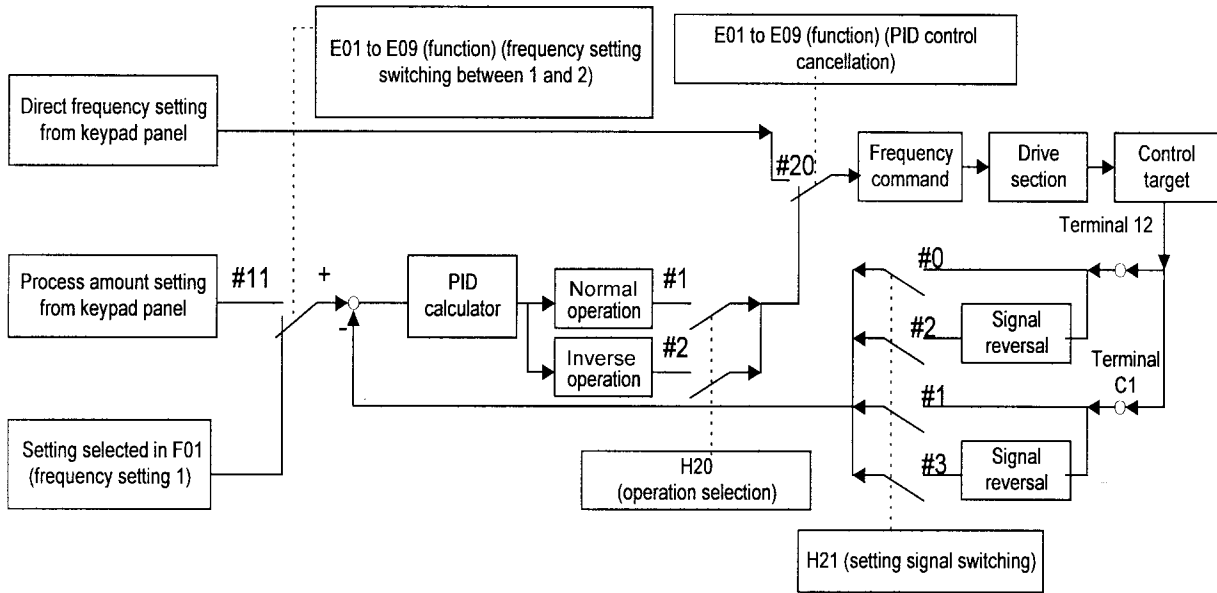

H22 PID control (P-gain)

H23 PID control (I-gain)

H24 PID control (D-gain)

These functions are not generally used alone, but are combined like **P** control, **PI** control, **PD** control, and **PID** control.

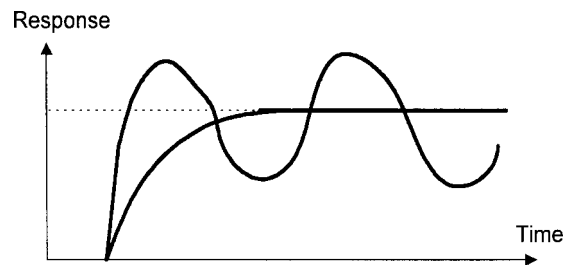

P operation

An operation using an output frequency proportional to deviation is called **P** operation, which outputs an operation amount proportional to deviation, though it cannot eliminate deviation alone.

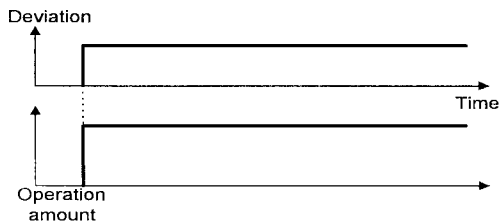

H 2 2 P D G A I N

Setting range: 0.01 to 10.0 times

P (gain) is the parameter that determines the response level for the deviation of **P** operation. Although an increase in gain speeds up response, excessive gain causes vibration, and a decrease in gain delays response.

I operation

An operation where the speed change of the output frequency is proportional to the deviation is called an **I** operation. An **I** operation outputs an operation amount as the integral of deviation and, therefore, has the effect of matching the feedback control amount to the target value (e.g., set frequency), though it deteriorates response for significant changes in deviation.

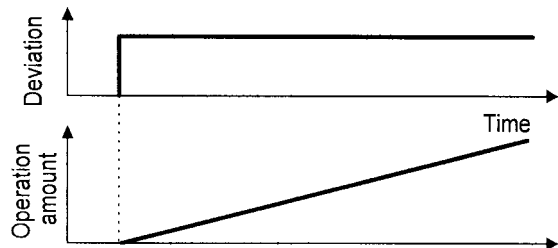

H 2 3 I D G A I N

Setting range: 0.0 (Inactive), 0.1 to 3600 seconds

H23 I-gain is used as a parameter to determine the effect of I operation. A longer integration time delays response and weakens resistance to external elements. A shorter integration time speeds up response, but an integration time that is too short causes vibration.

D operation

An operation where the output frequency is proportional to the deviation differential is called a D operation. It outputs an operation amount as the deviation differential and, therefore, is capable of responding to sudden changes.

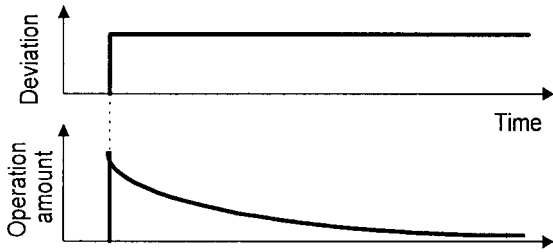

H 2 4 D D G A I N

Setting range: 0.00 (Inactive), 0.01 to 10.0 seconds

H24 D-gain is used as a parameter to determine the effect of a D operation. A longer differentiation time causes vibration by P operation quickly attenuating at the occurrence of deviation. Excessive differentiation time could cause vibration. Shortening the differentiation time reduces attenuation at the occurrence of deviation.

PI control

P operation alone does not remove deviation completely. P + I control (where I operation is added to P operation) is normally used to remove the remaining deviation. PI control always operates to eliminate deviation, even when the target value is changed or there is a constant disturbance. When I operation is strengthened, however, the response for rapidly changing deviation deteriorates. P operation can also be used individually for loads containing an integral element.

PD control

If deviation occurs under PD control, an output frequency larger than that of D operation alone occurs rapidly and prevents the deviation from expanding. For a small deviation, P operation is restricted. When the load contains an integral element, P operation alone may allow responses to vibrate due to the effect of the integral element, in which case PD control is used to attenuate the vibration of P operation and stabilize responses. In other words, this control is applied to loads in processes without a braking function.

PID control

PID control combines the P operation, the I operation which removes deviation, and the D operation which suppresses vibration. This control achieves deviation-free, accurate, and stable responses.

Adjusting PID value

Adjust the PID value while monitoring the response waveform on an oscilloscope or other instrument, if possible. Proceed as follows:

Increase the value of H22 P-gain without generating vibration.

Decrease the value of H23 I-gain without generating vibration.

Increase the value of H24 D-gain without generating vibration.

Adjust the response waveform as follows:

To remove the overshoot, increase the value of H23 I-gain, then decrease the value of H24 D-gain.

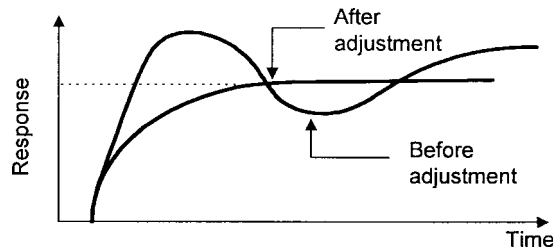

To stabilize response quickly, allowing for minimum overshoot, : decrease the value of H23 I-gain or increase the value of H24 D-gain.

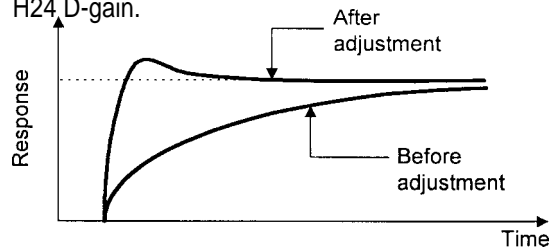

To suppress vibration with a period longer than the value of H23 I-gain, increase the value of H23.

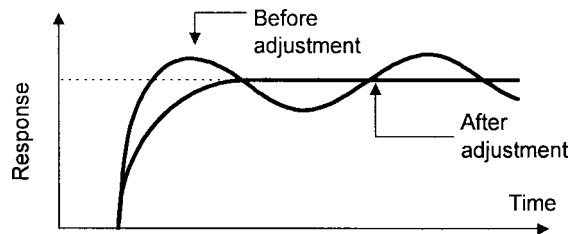

To suppress vibration with a frequency roughly equivalent to the value H24 D-gain, decrease the value of H24. If there is residual vibration with 0.0, decrease the value of H22 P-gain.

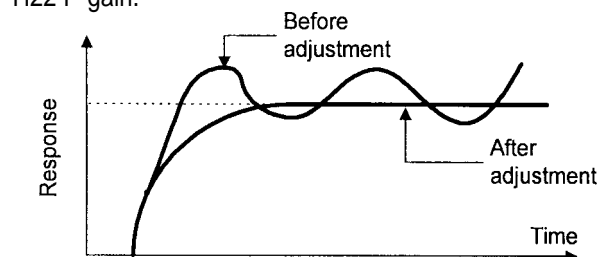

H25 PID control (Feedback filter)

H 2 5 F B F I L T E R

Setting range: 0.0 to 60.0 seconds

This filter is for feedback signal input from Terminal 12 or C1. This filter stabilizes operation of the PID control system. A set value that is too large, however, deteriorates response.

H26 PTC thermistor (mode select)

H 2 6 P T C M O D E

Set value 0: Inactive
1: Active

Set this function active when the motor has a PTC thermistor for overheat protection

Connect the PTC thermistor as shown in the figure below. Turn on switch PTC on the control PCB. The trip mode is activated by OH2: External thermal relay tripped.

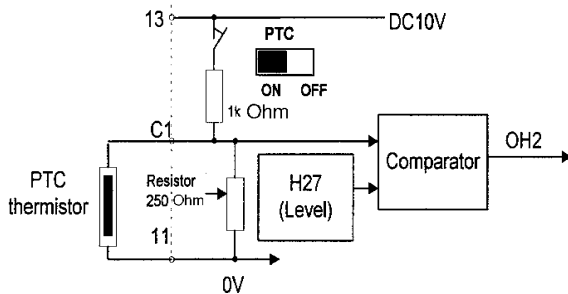

Note: Setting must be 0 when using a 4-20mA reference or feedback signal and the PTC switch is off.

H27 PTC thermistor (level select)

H 2 7 P T C L E V E L

Setting range: 0.00 to 5.00V

The voltage input to Terminal C1 is compared to the set voltage level. If the input voltage is equal to or greater than the set voltage, H26 PTC thermistor (Mode select) starts.

The PTC thermistor has its own alarm temperature. The internal resistance value of the thermistor largely changes at the alarm temperature. The operation voltage level is set using this change in the resistance value.

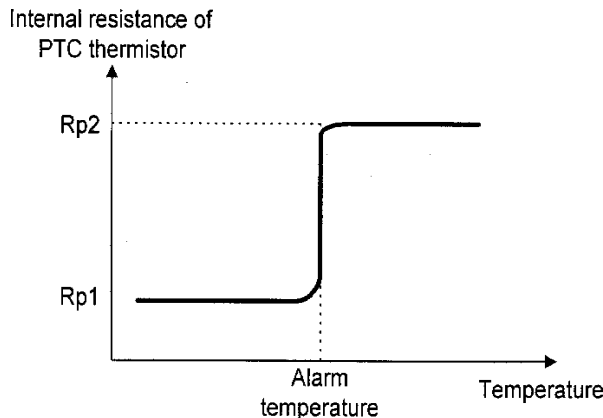

The previous figure for H26 PTC thermistor (Mode select) shows that a 250Ω resistor and the thermistor (resistance value Rp) are connected in parallel. Hence, Voltage Vc1 at Terminal C1 can be calculated using the following formula:

$$V_{C1} = \frac{250 \cdot R_p}{250 + R_p} \times 10 \text{ [V]}$$

$$1000 + \frac{250 \cdot R_p}{250 + R_p}$$

The operation level can be set by bringing Rp in the Vc1 calculation formula into the following range.

$$R_{p1} < R_p < R_{p2}$$

To calculate Rp, use the following formula:

$$R_p = \frac{R_{p1} + R_{p2}}{2} \text{ [Ohm]}$$

H28 Droop operation

H 2 8 D R O O P

Set value : -9.9Hz to 0.0Hz

When two or more drive motors operate a single machine, a higher load is placed on the motor that is rotating the fastest. Droop operation achieves a good load balance by applying drooping characteristics to speed against load variations.

Calculate the droop amount using the following formula:

$$\text{Droop amount} = \text{Base frequency} \times \frac{\text{Speed droop at rated torque [r/min.]}}{\text{Synchronous speed [r/min.]}} \text{ [Hz]}$$

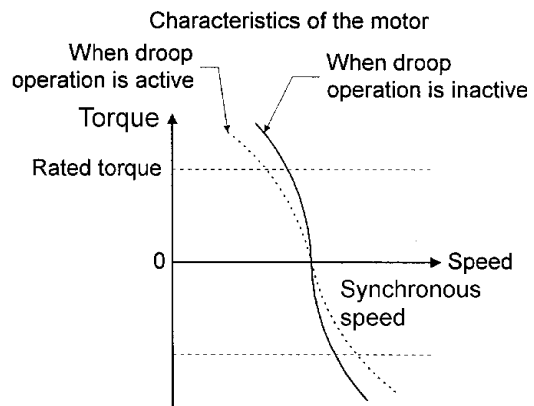

H30 Serial link (Function select)

H 3 0 L I N K F U N C

Setting range: 0 to 3

The link function (communication) provides a standard RS485 serial interface and optional fieldbus connections.

The serial link function includes:

- 1) Monitoring (data monitoring, function data check)
- 2) Frequency setting
- 3) Operation command (FWD, REV, and other commands for digital input)
- 4) Write function data

Communication can be enabled and disabled by a digital input. This function sets the serial link function when communication is enabled.

Value	Frequency	Operation
	Command	Command
0	Disabled	Disabled
1	Enabled	Disabled
2	Disabled	Enabled
3	Enabled	Enabled

The data monitoring and write functions are always enabled. Disabling communication by a digital input produces the same results as if this function were set to 0. If the bus option is installed, this setting selects the bus function, and the RS485 interface is restricted to monitoring and writing function data. If the bus option is not installed, this setting selects the RS485 function.

H31 RS485 (Address)

H39 RS485 (Response interval)

These functions set the conditions for RS485 RTU serial communication. Set the conditions according to the host device.

H 3 1 A D D R E S S

Setting range: 1 to 247

This function sets the station address of RTU. Maximum connected devices is 31 for an RS485 network.

H 3 2 M O D E O N E R

Setting range: 0 to 3

These functions configure the drive behavior in the event of a communication error.

Value	Processing at Communication Error
0	Immediate Er 8 trip (forced stop)
1	Continue operation within timer time, Er 8 trip after time expires
2	Continue operation and retry within timer time, then invoke an Er 8 trip if a communication error occurs. If an error does not occur, continue operation.
3	Continue operation.

H 3 3 T I M E R

Setting range: 0 to 60.0 seconds

This function sets the error processing timer value.

H 3 4 B A U D R A T E

Setting range: 0 to 3

This function sets the baud rate.

Value	Baud Rate
0	19200 bits/s
1	9600 bits/s
2	4800 bits/s
3	2400 bits/s

H 3 5 L E N G T H

This function sets data length.

Value	Data Length
0	8 bit

H 3 6 P A R I T Y

This function sets the parity bit.

Value	Parity Bit
0	None
1	Even
2	Odd

H 3 7 S T O P B I T S

This function sets the stop bit.

Value	Stop Bit
0	2 bits
1	1 bit

The stop bit is automatically configured by the value of the parity bit. For parity "NONE" the stop bit is 2 bits. For parity "EVEN" or "ODD" the stop bit is 1 bit.

H 3 8 N O R E S T

Setting range: 0 (no detection)
1 to 60 seconds

In a system where the drive is continuously polled within a specific time, this function detects that access was stopped due to an open circuit or other network fault and results in an Er 8 trip.

H 3 9 I N T E R V A L

Setting range: 0.00 to 1.00 second

This function sets the time from when a request is issued from the host device to when a response is returned.

A: Alternative Motor Parameters (Motor 2)

A01 Maximum frequency 2

A 0 1 M A X H z Ⓟ 2

This function sets the maximum frequency for Motor 2 output by the drive. It operates the same as F03 Maximum frequency 1. For details, see the explanation for F03.

A02 Base frequency 2

A 0 2 B A S E H z Ⓟ 2

This function sets the maximum output frequency in the constant torque area for Motor 2 (i.e., output frequency at rated output voltage). It operates the same as F04 Base frequency 1. For details, see the explanation for F04.

A03 Rated Voltage 2

A 0 3 R A T E D V 2

This function sets the rated voltage output to Motor 2. It operates the same as F05 Rated voltage 1. For details, see the explanation for F05.

A04 Maximum Voltage 2

A 0 4 M A X V Ⓟ 2

This function sets the maximum drive output voltage for Motor 2. It operates the same as F06 Maximum voltage 1. For details, see the explanation for F06.

A05 Torque boost 2

A 0 5 T R Q B O O S T 2

This function sets the torque boost function for Motor 2. It operates the same as F09 Torque boost 1. For details, see the explanation for F09.

A06 Electronic thermal relay 2 (select)

A07 Electronic thermal relay 2 (level)

A08 Electronic thermal relay 2 (thermal time constant)

A 0 6 E L C T R N O L 2
A 0 7 O L L E V E L 2
A 0 8 T I M E C N S T 2

These functions set the function of the electronic thermal overload relay for Motor 2. They operate the same as F10 to F12 Electronic thermal overload relay 1. For details, see the explanations for F10 to F12.

A09 Torque vector control 2

A 0 9 T R Q V E C T O R 2

This function sets the torque vector function for Motor 2. It operates the same as F42 Torque vector control 1. For details, see the explanation for F42.

A10 Number of motor-2 poles

A 1 0 M 2 P O L E S

This function sets the number of poles of Motor 2. It operates the same as P01 Number of Motor 1 poles. For details, see the explanation for P01.

A11 Motor 2 (capacity)

A 1 1 M 2 Ⓟ C A P

This function sets the capacity of Motor 2. It operates the same as P02 Motor 1 (Capacity). For details, see the explanation for P02. However, the related motor data functions change to A12 Motor 2 (Rated current), A15 Motor 2 (No-load current), A16 Motor 2 (%R1 setting), and A17 Motor 2 (%X setting).

A12 Motor 2 (Rated current)

A 1 2 M 2 Ⓟ L R

This function sets the rated current of Motor 2. It operates the same as P03 Motor 1 (Rated current). For details, see the explanation for P03.

A13 Motor 2 (Tuning)

A	1	3	M	2		T	U	N	1				
---	---	---	---	---	--	---	---	---	---	--	--	--	--

This function sets auto tuning for Motor 2. It operates the same as for P04 Motor 1 (Tuning). For details, see the explanation for P04.

A14 Motor 2 (On-line tuning)

A	1	4	M	2		T	U	N	2				
---	---	---	---	---	--	---	---	---	---	--	--	--	--

This function sets online tuning for Motor 2. It operates the same as P05 Motor 1 (On-line tuning). For details, see the explanation for P05.

A15 Motor 2 (No-load current)

A	1	5	M	2		I	O						
---	---	---	---	---	--	---	---	--	--	--	--	--	--

This function sets the no-load current of Motor 2. It operates the same as P06 Motor 1 (No-load current). For details, see the explanation for P06.

A16 Motor 2 (%R1 setting)

A17 Motor 2 (%X setting)

A	1	6	M	2		Ⓟ	%	R	1				
A	1	7	M	2		Ⓟ	%	X					

These functions set %R1 and %X of Motor 2. It operates the same as P07 Motor 1 (%R1 setting) and P08 Motor 1 (%X setting). For details, see the explanations for P07 and P08.

A18 Slip compensation control 2

A	1	8	S	L	I	P		C	O	M	P	2	
---	---	---	---	---	---	---	--	---	---	---	---	---	--

This function sets the amount of slip compensation of Motor 2. It operates the same as P09 Slip compensation control. For details, see the explanation for P09.

6. Protective Operations

6.1 List of Protective Functions

If an abnormality in the drive's operation occurs, the protective function will activate immediately to trip the drive and display the alarm name on the LED monitor while the motor coasts to a stop. A list of the alarms with their explanations is included in the table below, and troubleshooting charts in Section 7.

Table 6.1.1 List of Alarms and Causes

Alarm Name	Keypad Panel Display		Cause of Activation
	LED	LCD	
Overcurrent	OC1	OC DURING ACC	During acceleration
	OC2	OC DURING DEC	During deceleration
	OC3	OC AT SET SPD	Running at constant speed
Ground fault	EF	GROUND FAULT	If a ground fault in the drive output circuit is detected, the protective function will activate (for 40HP or more only). If a ground fault occurs in a drive rated at 30HP or less, the drive is protected by the overcurrent protection. If protection against personal injury or property damage is required, install a separate ground-fault protective relay or ground leakage circuit breaker.
	OU1	OV DURING ACC	During acceleration
	OU2	OV DURING DEC	During deceleration
Overvoltage	OU3	OV AT SET SPD	Running at constant speed
			If the DC link voltage in the main circuit exceeds the overvoltage detection level (230V series: 460 VDC, 400V series: 800 VDC), due to an increase in the regenerating current from the motor, the output shuts down. However, protection against inadvertent overvoltage (e.g., high-voltage line) may not be provided.
Undervoltage	LU	UNDERVOLTAGE	If the DC link voltage in the main circuit falls below the undervoltage detection level (230V series: 400 VDC, 460V series: 800 VDC) due to a lowered power supply, the output shuts down. If Function F14, "Restart after momentary power failure was selected," an alarm is not displayed. In addition, if the supply voltage falls to a level unable to maintain control power, an alarm may not be displayed.
Input phase loss	Lin	PHASE LOSS	If input power L1/R, L2/S and L3/T has any phase of the 3 phase power "OPEN" or if there is a significant disparity between the phases, the rectifying diodes or smoothing capacitors may be damaged. An Alarm will be displayed and the protective function will activate during heavy load.
Overheating of heat sink	OH1	FIN OVERHEAT	If the temperature of the heat sink rises due to a cooling fan failure, or the temperature of the heat sink is too low, the protective function activates.
External alarm	OH2	EXT ALARM	If the external alarm contacts on the braking unit, braking resistor, or external thermal O/L relay are connected to the control circuit Terminals (THR), the contacts will actuate according to contact signals.
Overheating internally	OH3	HIGH AMB TEMP	If the temperature inside the drive rises due to poor ventilation, etc., the protective function will activate.
Overheating of braking resistor	dbH	DBR OVERHEAT	If electronic thermal O/L relay (for braking resistor) Function F13 is selected, the protective function will activate to prevent the resistor from burning due to overheating caused by frequent use of the braking resistor.
Motor 1 overload	OL1	MOTOR1 OL	The protective function activates if the motor current exceeds the preset level, provided the electronic thermal O/L relay 1 Function F10 has been selected.
Motor 2 overload	OL2	MOTOR2 OL	If the second motor current exceeds the preset level when the operation is switched to drive the second motor, the protective function activates, provided the electronic thermal O/L relay 2 Function A04 was selected.
Inverter overload	OLU	INVERTER OL	If the output current exceeds the rated overload current, the protective function activates to provide thermal protection against overheating of the semiconductor elements in the drive's main circuit.
Blown fuse	FUS	DC FUSE OPEN	If the fuse in the drive is blown following a short-circuit or damage to the internal circuit, the protective function activates (for 40HP or more only).
Memory error	Er1	MEMORY ERROR	If a memory error occurs, such as missing or invalid data, the protective function activates.
Keypad panel communication error	Er2	KEYPD COM ERR	If a communication error or interrupt between the keypad panel and control circuit is detected, the protective function activates.
CPU error	Er3	CPU ERROR	If a CPU error occurs due to noise, etc., the protective function activates.
Option error	Er4	OPTN COM ERR	Error occurred while using an optional unit.
	Er5	OPTION ERROR	
Operating error	Er6	OPR PROCD ERR	Detects drive operating procedure error during drive startup. FWD or REV connected to Terminal CM when the main power is applied to the drive (F02 setting 3 or 4). Stop key on keypad is pressed in terminal operation (F02 setting 1 or 3). Detected timed alarm stop command.
Output wiring error	Er7	TUNING ERROR	If there is an open circuit or connection error in the drive output wiring during an auto-tuning procedure, the protective function activates.
Modbus RTU error	Er8	RS485 COM ERR	If an error occurs while using Modbus-RTU, the protective function activates.

Note: A number in front of an Alarm Code indicates multiple alarms. See page 4-15.

6.2 Alarm Reset

To release the trip status, enter the reset command by pressing the RESET key on the keypad panel or sending the appropriate signal to the RST terminal after removing the cause of the trip. Since the reset command is an edge operation, input a command sequence such as OFF-ON-OFF as shown in Fig.6-2-1.

When releasing the trip status, set the operation command to OFF. If the operation command is set to ON, the drive will start operation after resetting.

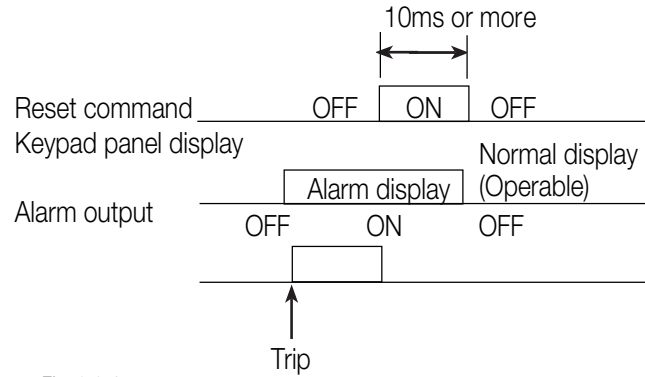

Fig. 6-2-1

WARNING

If the alarm reset is activated with the operation signal ON, the drive will restart suddenly, which may be dangerous. To ensure safety, disable the operating signal when releasing the trip status. Otherwise, an accident may occur.

7. Troubleshooting

7.1 Activation of Protective Function

(1) Overcurrent

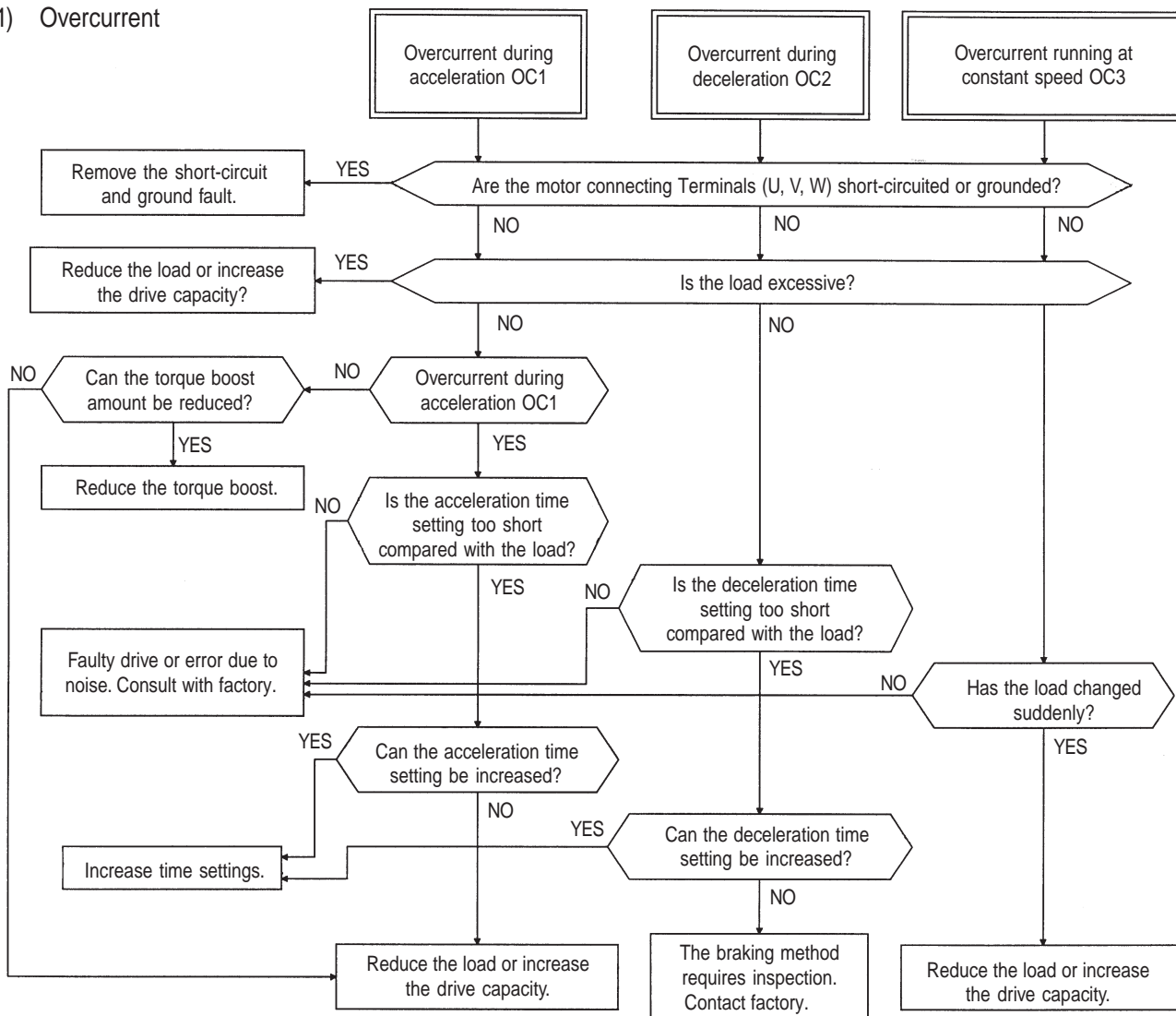

(2) Ground fault

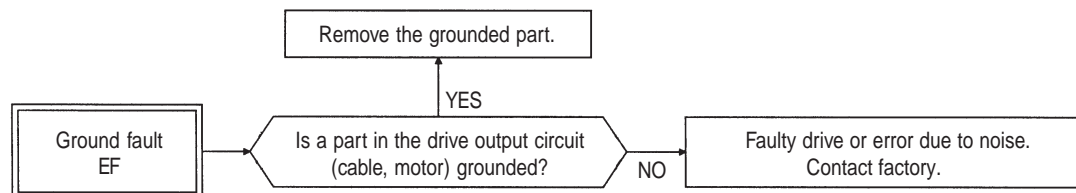

Note: The ground fault protective function is provided only for drives and motors rated 40HP or more.

(3) Fuse blown

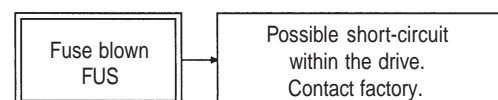

(4) Overvoltage

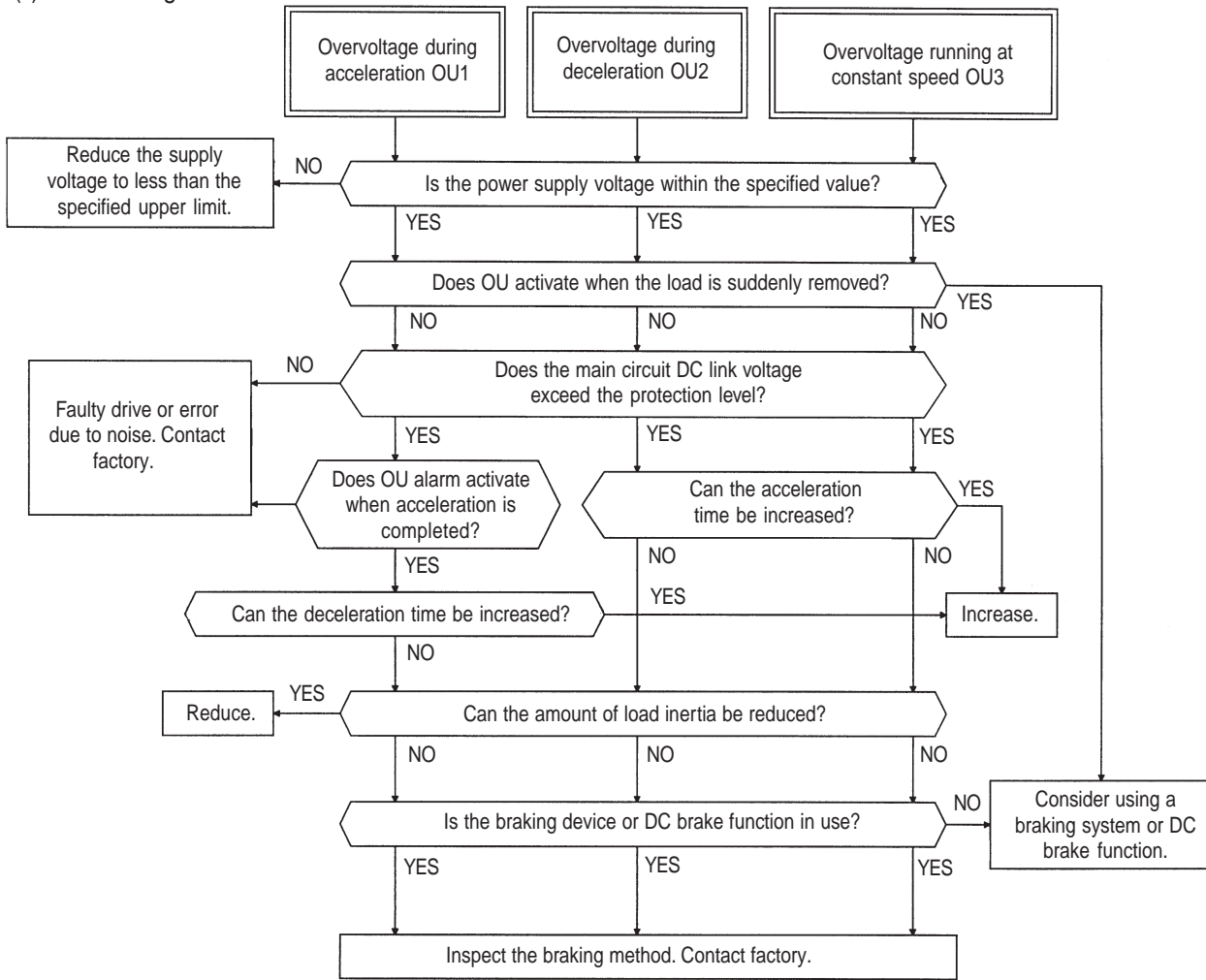

(5) Low voltage

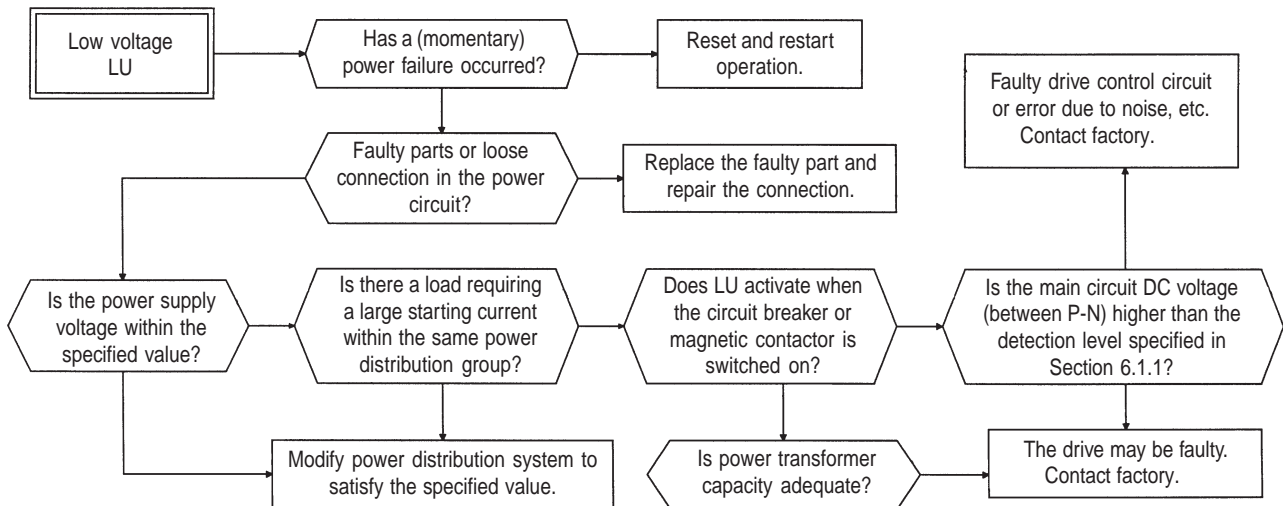

(6) Overheating internally and overheating of heat sink

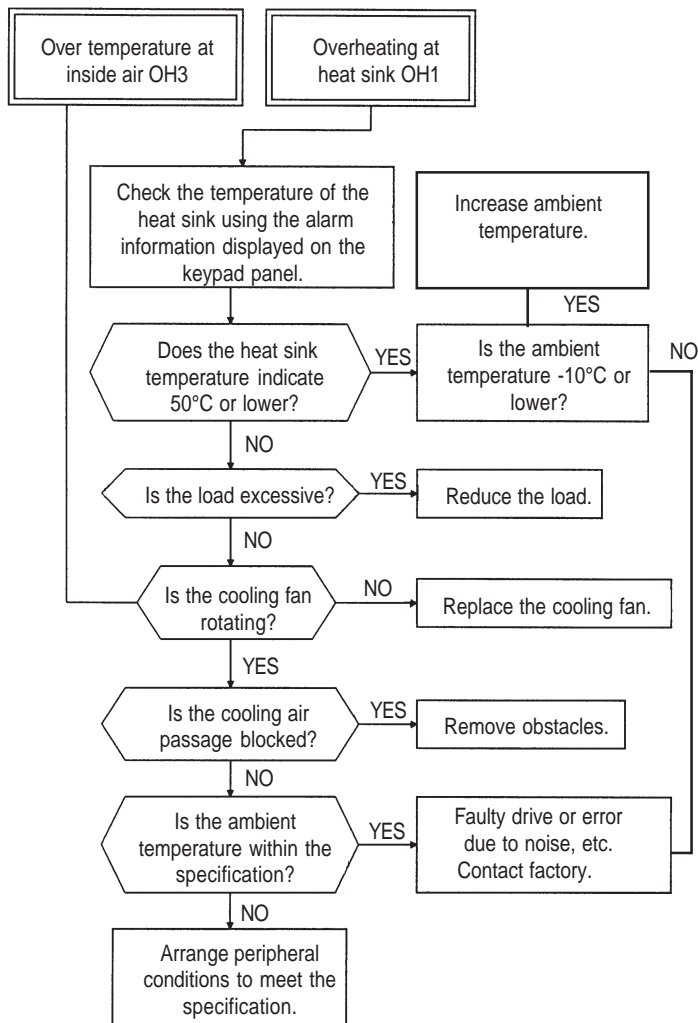

(7) External thermal relay tripped

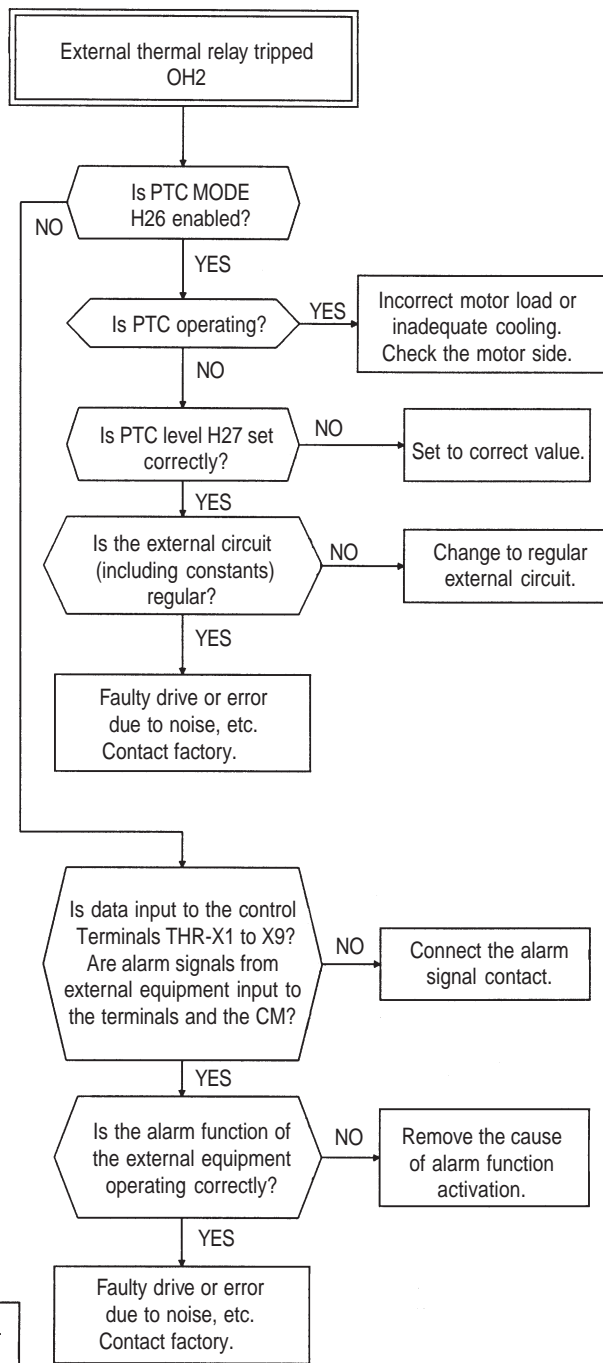

(8) Drive overload and motor overload

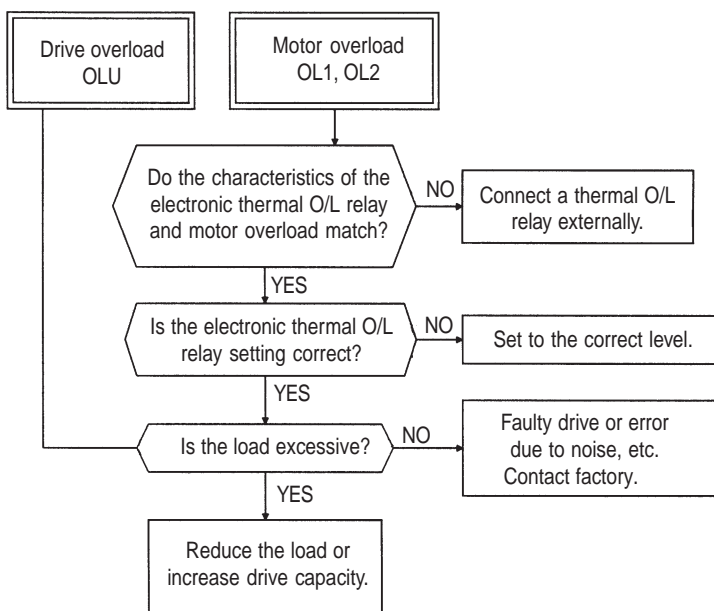

(9) Memory error Er1,
Keypad panel communication error Er2,
CPU error Er3

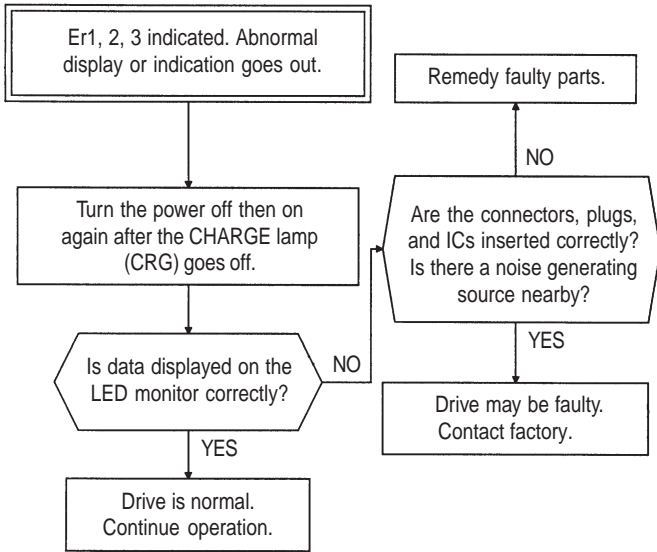

(10) Output wiring error

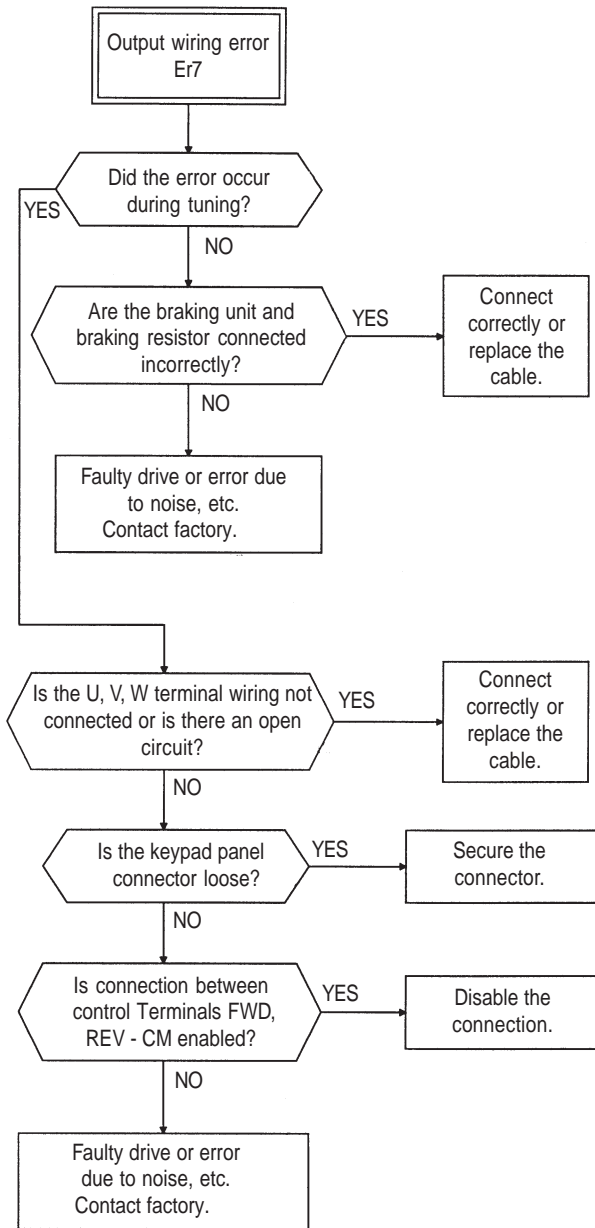

(11) Input Phase/Loss

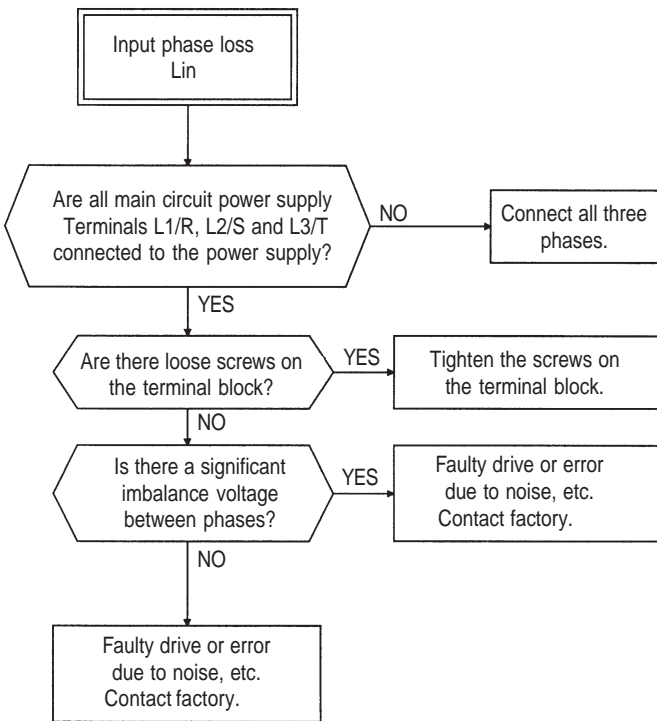

7.2 Abnormal Motor Rotation

(1) If motor does not rotate

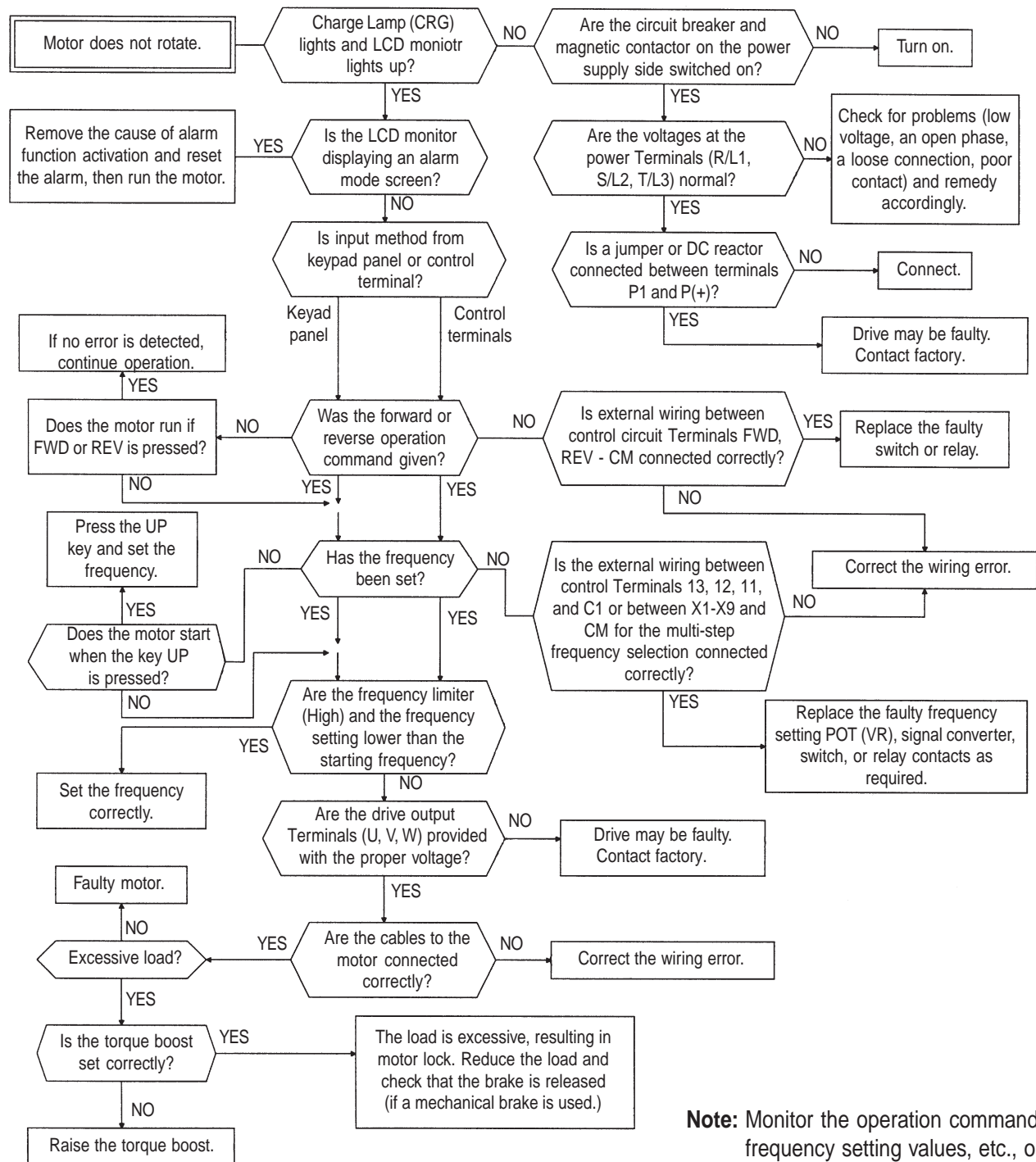

Note: Monitor the operation command or frequency setting values, etc., on the LED or LCD monitor after selecting the respective functions.

The motor does not rotate if the following commands are issued.

- An operation command is issued while the coast-to-stop or DC braking command is output.
- A reverse operation command is issued with the • H08 Rev. phase sequence lock• value set of 1.

(2) If the motor rotates but the speed does not change

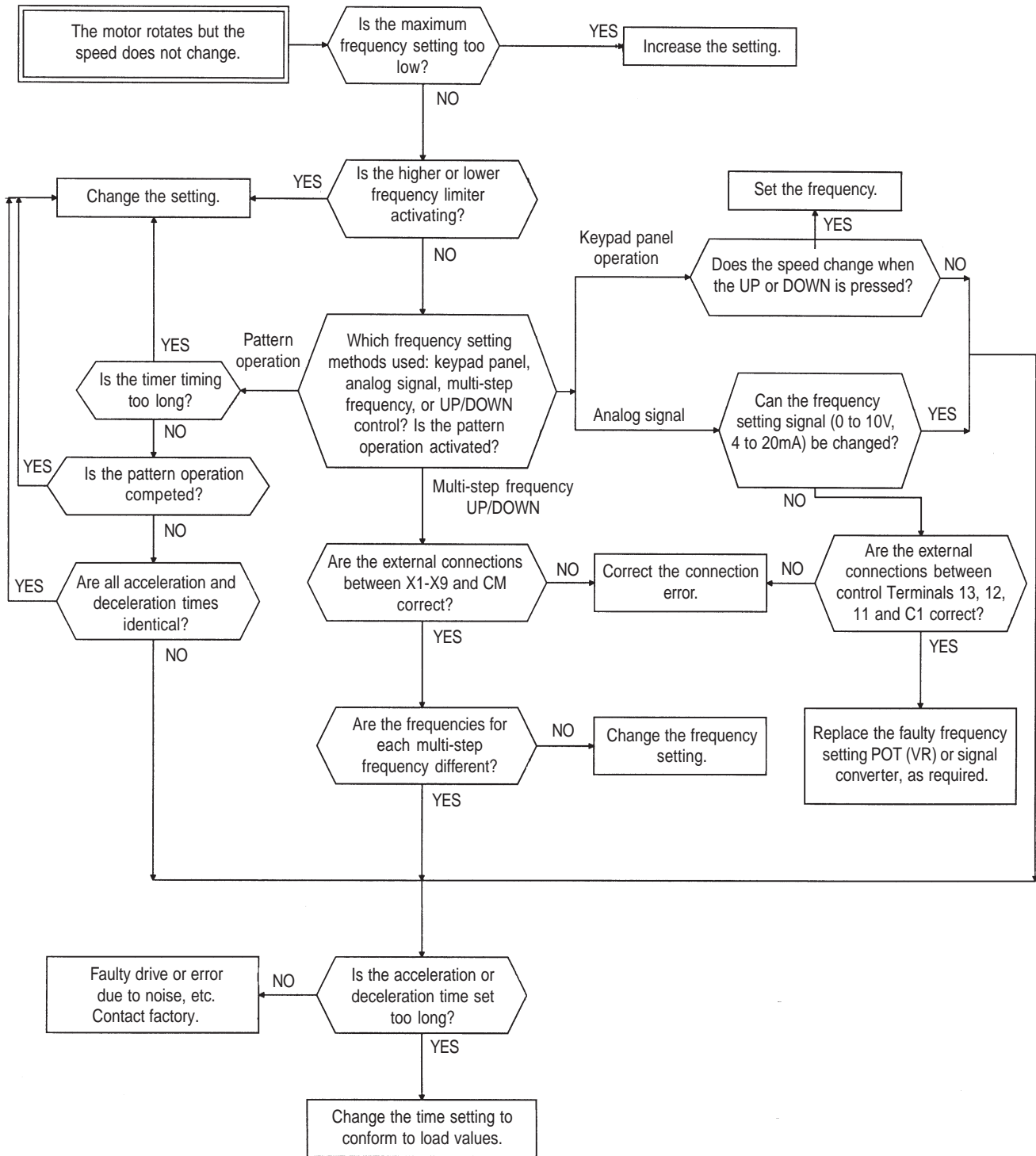

In the following cases, changing the motor speed is also restricted.

- Signals are input from control Terminals 12 and C1 when “F01 Frequency command 1” and “C30 Frequency command 2” are set to 3, and there is no significant change in the added value.
- The load is excessive, and the torque limiting and current limiting functions are activated.

(3) If the motor stalls during acceleration

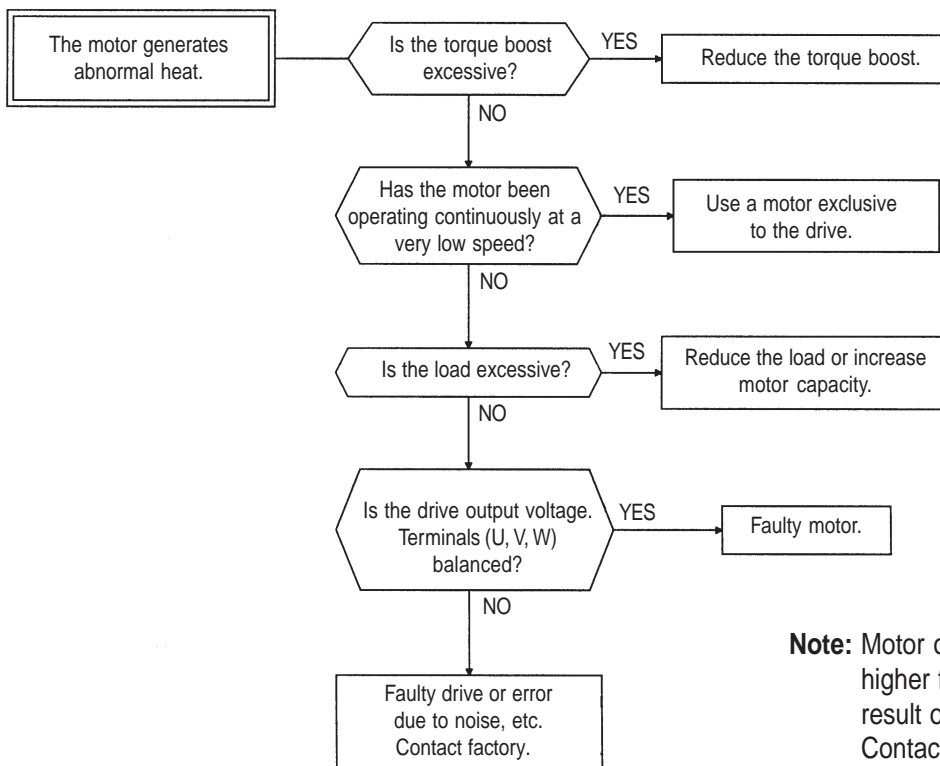
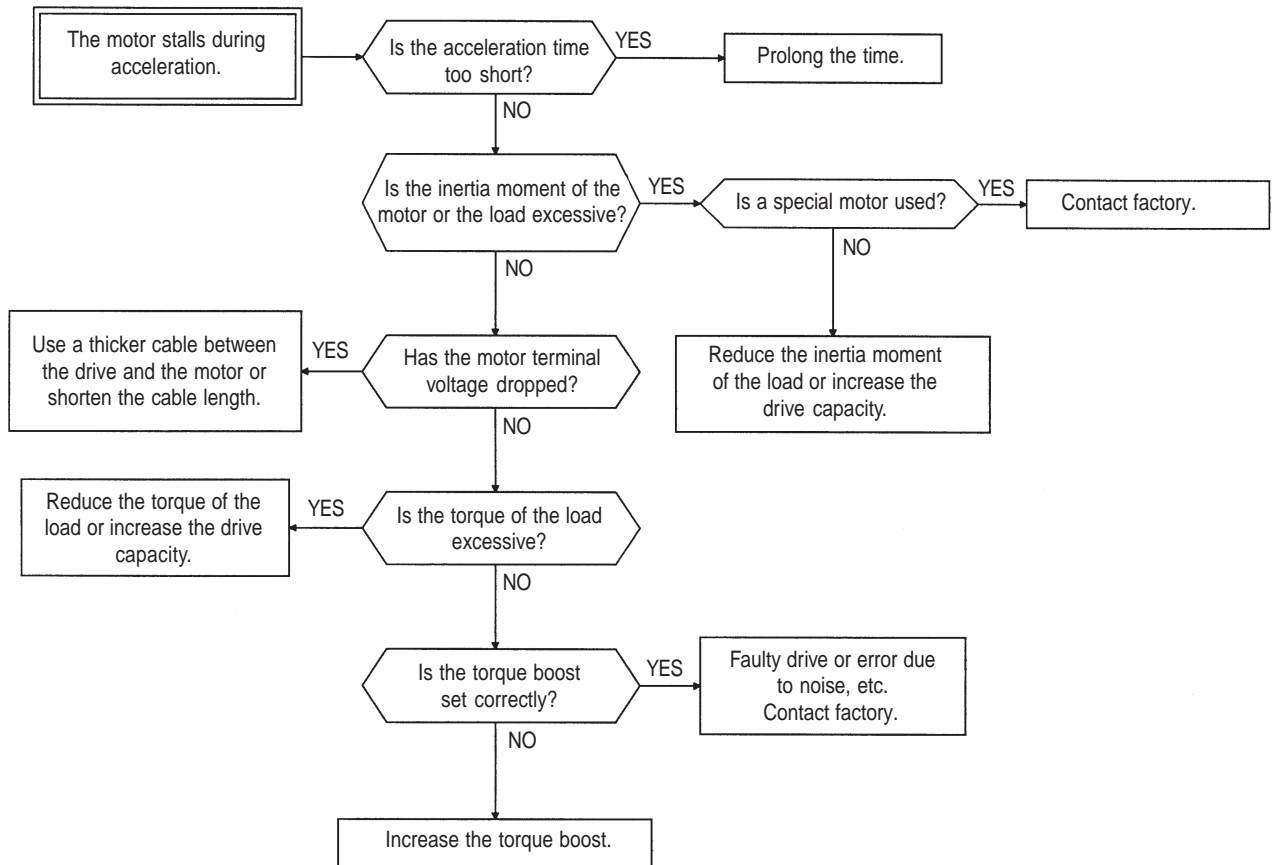

Note: Motor overheating following a higher frequency setting is likely the result of the current waveform. Contact factory.

Notes

8. Maintenance and Inspection

Proceed with daily inspections and periodic inspections to prevent malfunctions and ensure long-term reliability. Some tips regarding things to look for during these inspections are listed below.

8.1 Daily Inspections

During operation, a visual inspection for abnormal operation can take place externally without removing the covers.

The inspection should cover the following areas:

- (1) The performance, according to standard specifications, is as expected.
- (2) The environment conforms to standard specifications.
- (3) The keypad panel display is normal.
- (4) There are no abnormal sounds, vibrations, or odors.
- (5) There are no indications of overheating or discoloration.

8.2 Periodic Inspections

Periodic inspections should be made after stopping operations, turning off the power source, and removing the surface cover.

Note that after turning off the power, the smoothing capacitors in the DC section of the main circuit take time to discharge. To prevent electric shock, confirm with a multimeter that the voltage has dropped below the safety value (25 VDC or below) after the charge Lamp (CRG) goes off.

WARNING

- Wait at least five minutes after turning off the power supply for drives rated 30HP or less. Wait at least ten minutes for drives rated 40HP or more. Check that the charge Lamp (CRG) went off and that the voltage is 25 VDC or less between Terminals P(+) and N(-). Electric shock may occur.
- Only authorized personnel should perform maintenance and component replacement operations. Remove metal jewelry such as watches and rings, and always use insulated tools.
- Never modify the drive. Electric shock or injury may occur.

Area to Check	Items to Check	How to inspect	Evaluation Criteria	
Environment	<ol style="list-style-type: none"> 1) Check the ambient temperature, humidity, vibration, atmosphere (dust, gas, oil mist, water drops). 2) Is the area surrounding the equipment free of foreign objects? 	<ol style="list-style-type: none"> 1) Conduct a visual inspection and use appropriate meters. 2) Visual inspection 	<ol style="list-style-type: none"> 1) Results comply with all standard specifications. 2) The area is clear. 	
Voltage	Are the voltages in the main circuit and the control circuit normal?	Measure with a multi-meter.	Results comply with all standard specifications.	
Keypad panel	<ol style="list-style-type: none"> 1) Is the display hard to read? 2) Are the characters complete? 	<ol style="list-style-type: none"> 1) Visual inspection 2) Visual inspection 	1), 2) The display can be easily read and characters are normal.	
Structure (frame or cover)	<ol style="list-style-type: none"> 1) Is there abnormal sound or vibration? 2) Are nuts or bolts loose? 3) Is there deformation or damage? 4) Is there discoloration as a result of overheating? 5) Are there stains or dust? 	<ol style="list-style-type: none"> 1) Visual and aural inspection 2) Tighten 3), 4), 5) Visual inspection 	1), 2), 3), 4), 5) No abnormalities	
Main Circuit	Common	<ol style="list-style-type: none"> 1) Are there loose or missing nuts or bolts? 2) Are there deformations, cracks, damage, or discoloration due to overheating or deterioration in the equipment and insulation? 3) Are there stains and dust? 	<ol style="list-style-type: none"> 1) Tighten. 2), 3) Visual inspection 	1), 2), 3) No abnormalities Note: Discoloration of the bus bar does not indicate a problem.
	Conductors and wiring	<ol style="list-style-type: none"> 1) Is there discoloration or distortion of a conductor due to overheating? 2) Are there cracks, crazing or discoloration of the cable sheath? 	1), 2) Visual inspection	1), 2) No abnormalities
	Terminal block	Is there damage?	Visual inspection	No abnormalities
	Smoothing capacitor	<ol style="list-style-type: none"> 1) Is there electrolyte leakage, discoloration, crazing, or swelling in the case? 2) Is the safety valve not protruding, or are valves protruding too far? 3) Measure the capacitance if necessary. 	<ol style="list-style-type: none"> 1), 2) Visual inspection 3) *Estimate life expectancy from maintenance information and from measurements using capacitance measuring equipment. 	<ol style="list-style-type: none"> 1), 2) No abnormalities 3) Capacitance is within 85% of initial value
	Resistor	<ol style="list-style-type: none"> 1) Is there any unusual odor or damage to the insulation by overheating? 2) Is there an open circuit? 	<ol style="list-style-type: none"> 1) Visual and olfactory inspection 2) Conduct a visual inspection or use a multi-meter by removing the connection on one side. 	<ol style="list-style-type: none"> 1) No abnormalities 2) Less than about $\pm 10\%$ of the indicated resistance value
	Transformer and reactor	Is there abnormal buzzing or an unpleasant odor?	Aural, olfactory, and visual inspection	No abnormalities
	Magnetic conductor and relay	<ol style="list-style-type: none"> 1) Is there a rattling noise during operation? 2) Are the contacts rough? 	<ol style="list-style-type: none"> 1) Aural inspection. 2) Visual inspection. 	1), 2) No abnormalities
Control Circuit	Control PC board and connector	<ol style="list-style-type: none"> 1) Are there any loose screws or connectors? 2) Is there an unusual odor or discoloration? 3) Are there cracks, damage, deformation, or excessive rust? 4) Is there electrolyte leakage or damage to the capacitor? 	<ol style="list-style-type: none"> 1) Aural inspection. 2) Visual and olfactory inspection 3) Visual inspection 4) *Estimate life expectancy by visual inspection and maintenance information 	1), 2), 3), 4) No abnormalities
Cooling System	Cooling fan	<ol style="list-style-type: none"> 1) Is there abnormal sound or vibration? 2) Are nuts or bolts loose? 3) Is there discoloration due to overheating? 	<ol style="list-style-type: none"> 1) Aural and visual inspection. Turn manually (confirm the power is off). 2) Tighten. 3) Visual inspection 4) *Estimate life expectancy by maintenance information 	<ol style="list-style-type: none"> 1) The fan must rotate smoothly. 2), 3) No abnormalities
	Ventilation	Is there foreign matter on the heat sink or intake and exhaust ports?	Visual inspection	No abnormalities

See additional notes on following page.

Note: If equipment is stained, wipe with a clean cloth. Use a vacuum to remove dust. *Estimate of life expectancy based on maintenance information.

The maintenance information is stored in the drive keypad panel. It indicates the electrostatic capacitance of the main circuit capacitors and the life expectancy of the electrolytic capacitors on the control PC board and the cooling fans. Use this data as the basis to estimate the life expectancy of parts.

1) Determining the capacitance of the main circuit capacitors

The drive is equipped with a function to automatically indicate the capacitance of the capacitors installed in the main circuit when powering up the drive after disconnecting the power according to the prescribed conditions.

The initial capacitance values are set in the drive when shipped from the factory, and the decrease ratio (%) to those values can be displayed.

Use this function as follows:

- (1) Remove any option boards from the drive. Disconnect the DC bus connections to the main circuit [Terminals P(+) and N(-)] from the braking unit or other drives, if connected. The power factor correcting reactor (DC reactor) does not need be disconnected.
A power supply introduced to the auxiliary input [Terminals R0, T0] that provides control power should be isolated.
- (2) Disable all the digital inputs (FWD, REV, X1-X9) on the control terminals. Also disconnect RS485 serial communication, if used.
Turn on the main power supply. Confirm that the cooling fan is rotating and that the drive is not operating. (There is no problem if the "OH2 External thermal relay tripped" function is activated by the digital input terminal.)
- (3) Turn the main power off.
- (4) Turn on the main power again after verifying that the charge lamp is completely off.
- (5) Open the maintenance information on the keypad panel and confirm the capacitance values of the built-in capacitors.

2) Life expectancy of the PC control board

The actual capacitance of a capacitor is not measured in this case. However, the integrated operating hours for the control power supply, multiplied by the life expectancy coefficient as defined by the temperature inside the drive, will be displayed. Hence, the hours displayed may not agree with the actual operating hours, depending on the operational environment.

Since the integrated hours are counted in unit hours, power input for less than one hour will be disregarded.

3) Life expectancy of cooling fan

The integrated operating hours of the cooling fan are displayed. Since the integrated hours are counted in unit hours, power input for less than one hour will be disregarded.

The displayed value should be considered a rough estimate because the actual life of a cooling fan is influenced significantly by the temperature.

Table 8-2 Rough estimate of life expectancy using maintenance information

Parts	Recommended Level
Capacitor in main circuit	85% or less of the initial value
Electrolytic capacitor on control PC board	61,000 hours
Cooling fan	40,000 hours (5HP or less), 25,000 hours (Over 7-1/2HP)*

* Estimated life expectancy of a ventilation-fan at drive ambient temperature of 40°C.







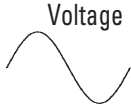
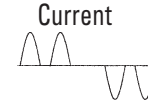

8.3 Main Circuit Measurements

The indicated values depend on the type of meter, because the harmonic component is included in the voltage and current of the main circuit power (input) and the output (motor) side of the drive. If measuring with a meter for commercial power frequency use, use the meters shown in Table 8-3-1.

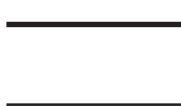
The power factor cannot be measured using power factor meters currently available on the market, which measure the phase difference between voltage and current. If power factors must be measured, measure the power, voltage, and current on the input side and output side, then calculate the power factor using the following formula:

$$\text{Power factor} = \frac{\text{Power [W]}}{\sqrt{3} \times \text{Voltage [V]} \times \text{Current [A]}} \times 100 [\%]$$

Table 8-3-1 Meters for Measuring Main Circuit

Item	Input (power supply) Side			Output (motor) Side			DC Link Circuit Voltage P(+) - N(-)
							
Meter name	Ammeter AR,S,T	Voltmeter VR,S,T	Powermeter WR,S,T	Ammeter AU,V,W	Voltmeter VU,V,W	Powermeter WU,V,W	DC Voltmeter V
Meter type	Moving iron type	Rectifier or moving-iron type	Digital power meter	Moving iron type	Rectifier type	Digital power meter	Moving coil type
Symbol							

Note: If the output voltage is measured with a rectifier type meter, an error may occur. Use a digital AC power meter to ensure accuracy.

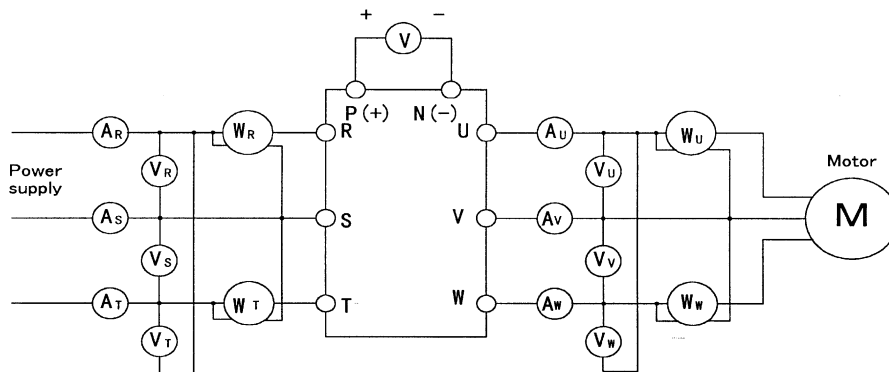

8.4 Insulation Test

Avoid megger testing on an drive, since an insulation test was completed at the factory. If a megger test must be completed, proceed as described below. Incorrect testing methods may result in drive damage.

If the specifications for the dielectric strength test are not followed, the drive may be damaged. If a dielectric strength test must be completed, contact the factory.

(1) Megger test for the main circuit

1. Use a 500 VDC megger and isolate the main power before starting measurements.
2. If the test voltage is connected to the control circuit, remove all connection cables to the control circuit.
3. Connect the main circuit terminals using common cables, as shown in Fig. 8-4-1.
4. Perform the megger test only between the common cables connected to the main circuit and ground (Terminal \ominus).
5. A megger indicating 5 meg ohms or more is normal. (This is the value measured with only the drive connected.)

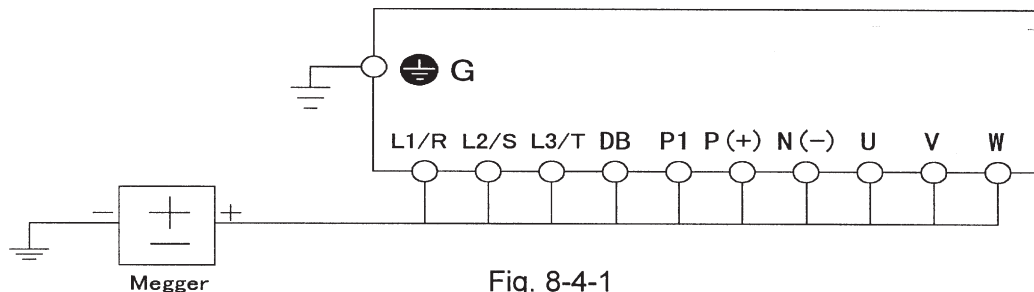

Fig. 8-4-1
Megger test

(2) Insulation test in the control circuit

Do not perform megger and dielectric strength tests on the control circuit. Use a resistance multimeter with a high resistance range to check the control circuit.

1. Remove all external cables from the control circuit terminals.
2. Conduct a continuity test between grounds. A result of 1 med ohm or more is normal.

(3) Exterior main circuit and sequence control circuit

Remove all cables from drive terminals to ensure that test voltage is not applied to the drive.

8.5 Replacement Parts

The life expectancy of a part depends on the type of part, the environment, and operating conditions. Parts should be replaced as shown in Table 8-5-1.

Table 8-5-1 Part replacement

Part name	Standard period for replacement	Comments
Cooling fan	3 years	Exchange for a new part
Smoothing capacitor	5 years	Exchange for a new part (determine after checking)
Electrolytic capacitor on the PC board	7 years	Exchange for a new PC board (determine after checking)
Fuse	10 years	Exchange for a new part
Other parts	—	Determine after checking

Notes:

9. Warranty Parts and Service

The purpose of this section is to provide specific instructions to the user of the standard drive referenced in this book regarding warranty administration and how to obtain assistance on both in-warranty and out-of-warranty equipment.

For all warranty procedures, refer to section 10 of this instruction manual to identify the part or assembly.

If assistance is required to determine warranty status, identify defective parts, or obtain the name of your local distributor, call:

Boston Gear Customer Support

Phone: 1-888-999-9860

At the number listed above, a Technical Support Coordinator will take information about your call and will put you in touch with the appropriate department.

Before calling the number above to determine warranty status, the drive serial number will be required. This is located on the drive nameplate. If the drive is still under warranty, further information will be required per the "In-Warranty Failure Checklist" shown on page 9-2 of this instruction manual.

IN-WARRANTY FAILURE CHECKLIST

To assist with warranty troubleshooting, the following information is required. This data is needed to evaluate the cause in an effort to eliminate any further failures.

Model No.: _____

Serial No.: _____

Start-Up Date: _____

Failure Date: _____

Status When Failure Occurred (check one):

Power-Up _____ Running _____ Accel _____ Decel _____

Explanation of Failure _____

Application Information (check Yes or No)

Input Transformer: Yes _____ No _____

If Yes: KVA _____

L1 Volts _____ L2 Volts _____ L3 Volts _____

Power Factor Correction Capacitors: Yes _____ No _____

If Yes: Microfarrad _____

Other Equipment on Same Power Yes _____ No _____

If Yes, what?

Line Reactor on Input Yes _____ No _____

Input Starter Yes _____ No _____

Output Starter Yes _____ No _____

Motor Overloads Yes _____ No _____

Control Terminals Used (circle if used)

	30A	Y5A	CMY	Y3	Y1	C1	FMA	FMP	PLC	X1	X2	X3	X4	X5	X6	X7	X8	X9
30C	30B	Y5C	Y4	Y2	11	12	13	V2	CM	CM	FWD	REV	P24	P24	DX	DX	SD	

Function Codes Different From Factory Settings

Function Code	Setting	Function Code	Setting

Failure Message (see Section 4)

Latest Fault _____ Previous Faults: No Message _____

Hz _____ 1. _____

A _____ 2. _____

V _____ 3. _____

After all of the Checklist information is acquired, contact the following number for assistance: (800) 816-5608.

10. ACE40 Replacement Parts

Catalog No.	Rating	Drive HP & Quantity per drive											
		1/4	1/2	1	2	3	5	7.5	10	15	20	25	30

230 VAC, 30HP and Below

Main Control Card														
6608042		1	1	1	1	1	1	1	1	1	1	1	1	1
Gate Driver & Power Supply Card														
6608059		1												
6608060			1											
6608061				1										
6608062					1									
6608063						1								
6608064							1							
6608065								1						
6608066									1					
6608067										1				
6608068											1			
6608069												1		
6608070													1	
KEYPAD PANEL (Only one type per drive)														
6608047	NEMA 1	1	1	1	1	1	1	1	1	1	1	1	1	1
6608048	NEMA 4, 12	1	1	1	1	1	1	1	1	1	1	1	1	1
DC CAPACITOR														
3402511	PCB				1									
3402512	PCB					1								
3402513	PCB						1							
3402519	2700µF							1		2				
3402520	3900µF								1		2			
3402521	4700µF											2		
3402522	5400µF												2	
* Located on Gate drive & Power supply Card														
FAN														
5101193					1	1	1							
5101194								1	1	2	2	2	2	
POWER MODULE														
3301302	30A 600V				1	1								
3301303	50A 600V						1							
3301297	75A 600V							1						
3301292	100A 600V								1					
3301294	150A 600V									1	1			
3301295	200A 600V											1	1	
* Located on Gate drive & Power supply Card														
RECTIFIER MODULE														
3301286	75A 800V								1	1				
3301279	120A 800V										1	1		
3301280	180A 800V												1	1
CHARGE RESISTOR														
3521026	30W 6.6WJ								1	1				
3521028	80W 2.5WJ										1	1	1	1
* Located on Gate drive & Power supply Card														
FRONT COVER														
6003055		1	1	1										
6003056					1	1	1							
6003057								1	1					
6003058											1	1	1	1
INTERNAL DB RESISTOR														
3540199	100W 40W	1	1	1										
3540201	40W 80W				1	1	1							
3540203	24W 90W							1	1					

Catalog No.	Rating	Drive HP & Quantity per drive					
		40	50	60	75	100	125

230 VAC, 40HP and Above**Main Control Card**

6608041		1	1	1	1	1	1
---------	--	---	---	---	---	---	---

Gate Driver & Power Supply Card

6608049		1					
6608050			1				
6608051				1	1		
6608052						1	
6608053							1

KEYPAD PANEL

6608048		1	1	1	1	1	1
---------	--	---	---	---	---	---	---

DC CAPACITOR

3402526	400V 3000 μ F	4					
3402523	400V 3600 μ F		4				
3402524	400V 4500 μ F			4			
3402525	400V 5900 μ f				4	5	6

FAN

5101192		1	1	2	2	2	4
---------	--	---	---	---	---	---	---

(Standard)

5101189		2					
5101187			2	2		3	4
5101190					2		

(For NEMA12 Heatsink)

5101195		2					
5101188			2	2		3	4
5101196					2		

IGBT MODULE

3301288		3					
3301301			3				
3301289				6	6	9	12

RECTIFIER MODULE

3301283		3	6	6	9	9	9
---------	--	---	---	---	---	---	---

CHARGE RESISTOR

3521029	80W 7.5ohm	1	1	1	1	2	2
---------	------------	---	---	---	---	---	---

DC CONTACTOR

3210329	AC220VAUX2B	1					
3210328	AC220VAUX2B		2	2	2		
3210330	AC220VAUX2B					2	
3210331	AC200-240V						1

DC FUSE

3002610		1	1				
3002611				1	1		
3002607						1	1

INPUT MODULE CARD

6608043		1	1	1	1		
6608045						1	1

Catalog No.	Rating	Drive HP & Quantity per drive										
		1/2	1	2	3	5	7.5	10	15	20	25	30
460 VAC, 30 Hp and Below												
Main Control Card												
6608042		1	1	1	1	1	1	1	1	1	1	1
Gate Driver & Power Supply Card												
6608071		1										
6608072			1									
6608073				1								
6608074					1							
6608075						1						
6608076							1					
6608077								1				
6608078									1			
6608079										1		
6608080											1	
6608081												1
KEYPAD PANEL (Only one type per drive)												
6608047	NEMA1	1	1	1	1	1	1	1	1	1	1	1
6608048	NEMA Type4	1	1	1	1	1	1	1	1	1	1	1
DC CAPACITOR												
3402514	PCB	*	*									
3402515	PCB			1								
3402516	PCB				1							
3402517	1500 μ F					1						
3402518	2000 μ F						2					
3402519	2700 μ F							2				
3402520	3900 μ F								2			
3402521	4700 μ F									2		
3402522	5400 μ F										2	
* Located on Gate drive & Power supply Card												
FAN												
5101193				1	1	1						
5101194							1	1	2	2	2	2
POWER MODULE												
3301304	15A 1200V	*	*									
3301303	25A 1200V			1	1							
3301296	50A 1200V						1	1				
3301298	75A 1200V								1	1		
3301293	100A 1200V										1	1
* Located on Gate drive & Power supply Card												
RECTIFIER MODULE												
3301285	75A 1600V	*	*	*	*	*						
3301281	70A 1600V						1	1				
3301278	100A 1600V								1	1		
* Located on Gate drive & Power supply Card												
CHARGE RESISTOR												
3521025	30W 20WJ	*	*	*	*	*						
3521027	80W 10WJ						1	1				
* Located on Gate drive & Power supply Card												
FRONT COVER												
6003055		1	1									
6003056				1	1	1						
6003057							1	1				
6003058									1	1	1	1
INTERNAL DB RESISTOR												
3540198	720W 30W	1										
3540200	470W 40W		1									
3540202	200W 80W			1	1	1						
3540204	100W 90W						1	1				

Catalog No.	Rating	Drive HP & Quantity per drive															
		40	50	60	75	100	125	150	200	250	300	350	400	450	500	600	

460 VAC, 40HP and Above

Main Control Card

6608041		1	1	1	1	1	1	1	1	1	1	1	1	1	1	1
---------	--	---	---	---	---	---	---	---	---	---	---	---	---	---	---	---

Gate Driver & Power Supply Card

6608054		1														
6608055			1													
6608056				1	1											
6608057						1										
6608058							1	1								
6608082									1	1						
6608083											1	1				
6608084													1	1	1	1

Gate Drive Amplifier Card

6608085													3	3	3	3
---------	--	--	--	--	--	--	--	--	--	--	--	--	---	---	---	---

KEYPAD PANEL

6608048		1	1	1	1	1	1	1	1	1	1	1	1	1	1	1
---------	--	---	---	---	---	---	---	---	---	---	---	---	---	---	---	---

DC CAPACITOR

3402526	400V 3000µF	4														
3402523	400V 3600µF		4													
3402524	400V 4500µF			4			6									
3402525	400V 5900µF				4	4		6	8		12					
3402527	400V 7400µF									8		12				
3402528	400V 9300µF												20	20	26	26

FAN

5101192		1	1	1	1	2	2	2	3	3	4	4	4	4		
5101197													3	3	4	4
5101198															4	4

(Standard)

5101189		2														
5101187			2	2			3	3								
5101190					2	2			3	3	4	4				

(For NEMA12 Heatsink)

5101195		2														
5101188			2	2			3	3								
5101196					2	2			3	3	4	4				

IGBT MODULE

3301287		3														
3301300			3													
3301290				3	3											
3301299						6										
3301291							6	6	9	9	12	12	18	18	24	24

Catalog No.	Rating	Drive HP & Quantity per drive													
		40	50	60	75	100	125	150	200	250	300	350	400	450	500

460 VAC, 40 Hp and Above**RECTIFIER MODULE**

3301284		3	3						12	12						
3301282				3	3	6	6	6			12	12	24	24	30	30

CHARGE RESISTOR

3521029	80W 7.5ohm	1	1	1	1	1	2	2	2	3	3	4				
3521030	600W 5ohm												2	2	2	2

DC CONTACTOR

3210328	AC220VAUX2B	1	1	1	1	2	2	2								
3210330	AC220VAUX2B								2	2						
3210331	AC200-240V										1					
3210332	AC200-240V											1				
3210333	AC200-240V												2	2	2	2

DC FUSE

3002612	600V 150A	1	1													
3002613	600V 200A			1												
3002614	600V 300A				1	1										
3002608							1	1								
3002609									1							
3002615										1	1					
3002616												1				
3002617													1	1		
3002618															1	1

TRANSFORMER

3411298		1														
3411299			1	1	1	1	1									
3411297								1	1	1	1	1				
3411300													1	1	1	1

INPUT MODULE CARD

6608044		1	1	1	1	1	1	1								
6608046									1	1	1	1	1	1	1	1

Notes:

11. Specifications

11.1 Standard Specifications

Three-phase 230V series																				
(NEMA Type1)																				
(NEMA Type12)																				
(NEMA Type4)																				
(Open, Type 12 Heatsink)																				
(Open)																				
Nominal 230V system applied motor	HP	1/4	1/2	1	2	3	5	7.5	10	15	20	25	30	40	50	60	75	100	125	150
Output ratings	kVA	0.59	1.1	1.9	3.1	4.3	6.7	9.9	13	18	23	29	34	45	57	71	85	112	137	173
Rated Capacity *1)	V	3-phase, 200V /50Hz, 200V /220V, 230V /60Hz																		
Rated Current *3)	A	1.5	3.0	5.0	8.0	11	17	25	33	46	59	74	87	115	145	180	215	283	346	425
Overload Capability	150% of rated current for 1min, 200% of rated current for 0.5s																			
Rated Frequency	Hz	50, 60Hz																		
Phases, Voltage, Frequency	3-phase, 200 to 230V, 50/60Hz																			
Voltage / frequency variations	-Voltage : +10 to -15% (Voltage unbalance *5) : 2% or less)																			
Momentary voltage dip capability *6)	When the input voltage is 165V or more, the inverter can be operated continuously. When the input voltage drops below 165V from rated voltage, the inverter can be operated for 15ms (within 85% load of nominal applied motors)																			
Setting	Maximum Freq.	50 to 400Hz *1)																		
	Base Freq.	25 to 400Hz *1)																		
	Starting Freq.	0.1 to 60Hz, Continuous time: 0.0 to 10.0s																		
	Carrier Freq. *8)	0.75 to 15KHz																		
Accuracy (Stability)	The minimum carrier frequency changes depend on maximum output frequency.																			
Setting resolution	-Analog setting	: ±0.2% of Maximum frequency (at 25 ±10 degrees C)																		
	-Digital setting	: ±0.01% of Maximum frequency (at -10 to +50 degrees C)																		
	-Analog setting	: 1/3000 of Maximum frequency ex) 0.02Hz at 60Hz, 0.15Hz at 400Hz																		
	-Digital setting	: 0.01Hz at Maximum frequency of up to 99.99Hz (0.1Hz at Maximum frequency of 100Hz and above)																		
	-Link setting	: Two methods are selectable.																		
		*1) 20000 of Maximum frequency ex.) 0.003Hz at 60Hz, 0.01Hz at 400Hz																		
		*4) 0.01Hz (Fixed)																		
Control	Volt/Freq Characteristic	80 to 240V (with AVR control) at base and maximum frequency, adjustable																		
	Torque boost	Automatic (setting code) : 0.0 Manual (setting code) : 2.0 to 20.0																		
		Constant torque load Variable torque load 0.1 to 1.9 *9)																		
Starting torque	200% (with Dynamic torque vector control selected)																			
Standard	Braking torque	150%																		
	Time	s 10 5 5 3 5 3 2 3 2																		
	Duty cycle	%																		
Options	Braking torque	150%																		
	Time	s 90 45 45 45 30 20 20 10 8																		
	Duty cycle	%																		
		37 22 18 10 7 5 5 5 5																		
DC injection braking	Starting frequency: 0.1 to 60.0Hz, Braking time: 0.0 to 30.0s, Braking level: 0 to 100% of rated current																			
Enclosure	NEMA Type1, Type4																			
Cooling method	Natural																			
Standards	-UL/cUL	Fan cooling																		
		-LOW VOLTAGE directive -IEC 61800-2 (Rating, EMC directive -IEC 61800-3 (EMC product specifications for low voltage adjustable frequency standard including specific test methods) a.c. power drive systems)																		

NOTES

- *1) Drive output capacity [kVA] at 230V.
- *2) Output voltage is proportional to the power supply voltage and can't exceed the power supply voltage.
- *3) Current derating may be required in case of low impedance load such as high frequency motor.
- *4) 220 to 230V/50Hz : Order individually
- *5) Reference to the IEC 61800-3(5.2.3)

Unbalance in power supply voltage [%] = $\frac{\text{Maximum voltage[V]} - \text{Minimum voltage[V]}}{\text{3-phase averaging voltage[V]}} \times 100$ [%]

- *6) Input power : 85%
- *8) If carrier frequency is set at more than 10kHz and an overheat condition (detected by internal thermal sensor) occurs, the drive will automatically reduce carrier frequency to 8kHz in order to avoid trip.(Available up to 30HP unit)
- *9) When setting into 0.1, the starting torque gets 50%
- *10) With a nominal applied motor.(Average torque when the motor decelerates and stops from 60Hz. It may change according to the motor loss.)
- *11) Above 120Hz application, please contact the factory.

11.2 Common Specifications

Item		Explanation	
Control	Control Method	Sinusoidal wave PWM control (with V/F control, torque vector control, PG feedback vector control (option))	
	Output frequency	Maximum frequency	50 to 400 Hz variable setting
		Base frequency	25 to 400 Hz variable setting
		Starting frequency	0.1 to 60 Hz variable setting. Holding time: 0.0 to 10.0 seconds
		Carrier frequency	0.75 to 15k Hz (75HP or less) 0.75 to 10k Hz (100HP or more)
		Accuracy (stability)	Analog setting: +/- 0.2% or less of the maximum frequency (at 25 +/- 10°C) Digital Setting: +/- 0.01% or less of the maximum frequency (-10 to +50°C)
		Setting resolution	Analog setting: 1/3000 of max. frequency (e.g. 0.02 Hz / 60 Hz, 0.05 Hz / 150 Hz) Digital setting: 0.01 Hz (99.99 Hz or less), 0.1 Hz (100.0 Hz or more)
	Voltage/frequency Characteristics	Output voltage at base frequency can be adjusted separately, such as 80 to 240V (200V series) or 320 to 480V (400V series)	
	Torque Boost	Auto: Optimum control corresponding to the load torque. Manual: 0.1 to 20.0 code setting (energy savings reduced torque, constant torque (strong) etc.)	
	Accelerating/decelerating time		0.01 to 3600 seconds Four accelerating and decelerating time settings are possible independent of each other by selecting digital input signals.
		In addition to linear acceleration and deceleration, either S-shaped acceleration/deceleration (weal/strong) or curvilinear acceleration/deceleration can be selected.	
DC injection braking	Starting frequency: 0.0 to 60 Hz, braking time: 0.0 to 30.0 seconds Braking levels: 0 to 100%		
Function equipped	Frequency upper and lower limiter, bias frequency, frequency gain, jump frequency, pick-up operation, restart after momentary power failure, switching operation from line to drive, slip compensation control, automatic energy saving operation, regeneration avoiding control, droop control, torque limiting (2-strp), torque control, PID control, second motor switching, cooling fan ON/OFF control.		
Operation	Operation method	Keypad panel: Run by FWD REV keys, stop by STOP key. Terminal input: Forward/Stop command, Reverse/Stop command, Coast-to-Stop command, Alarm reset, acceleration/deceleration selection, multistep frequency selection, etc.	
	Frequency setting	Keypad panel: setting by UP and DOWN keys External potentiometer: External freq. Setting POT (VR) (1 to 5k ohms) Analog input: 0 to +10V (0 to 5V), 4 to 20 mA, 0 to ± 10V (FWD/REV operation) +10 to 0 (reverse operation), 20 to 4 mA (reverse operation) UP/DOWN control: Frequency increases or decreases as long as the digital input signals are turned on Multistep frequency selection: Up to 15 steps are selectable by a combination of digital input signals (four kinds) Link operation: Operation by RS485 (standard) Program operation: Pattern operation by program Jogging operation: Jogging operation by FWD, REV key or digital input signals.	
	Operation status signal	Transistor output (4 signals): Running, frequency, arrival, frequency detection, overload early warning, etc. Relay output (2 signals): Alarm output (for any fault), multi-purpose output signals Analog output (1 signal): Output frequency, output current, output voltage, output torque, power consumption, etc. Pulse output (1 signal): Output frequency, output current, output power, output torque, power consumption, etc.	

11.2 Common Specifications (continued)

		Item	Explanation
Indication		Digital display LED	Output frequency, setting frequency, output current, output voltage, motor synchronous speed, line speed, load rotation speed, calculated PID value, PID command value, PID feedback value, alarm code.
		Liquid crystal display	Operation information, operational guide, functional code/name/setting data, alarm information, tester function, motor load rate measuring function (Maximum/average current (rms) during measuring period, maintenance information (integrated operation hours, capacitance measurement for main circuit capacitors, heatsink temperature, etc.
		Language	Six languages (Japanese, English, German, French, Spanish, Italian)
		Lamp display	Charging (voltage residual), operation indication
		Protective function	Overcurrent, short-circuit, ground fault, overvoltage, undervoltage, overload, overheating, blown fuse, motor overload, external alarm, input open-phase, output open0phase (when tuning), braking resistor protection, CPU and memory error, keypad panel communications error, PTC thermistor protection, surge protection, stall prevention, etc.
Environment		Installation location	Indoor, altitude less than 3300 feet (1000m), free from corrosive gas, dust and direct sunlight.
		Ambient temperature	-10 to +50°C (+14 to 122°F) (ventilating cover must be removed under conditions exceeding +40°C (+104°F) for models rated at 30HP or less)
		Vibration	3mm peak from 2-9 Hz, 9.8 m/s ² from 9-20 Hz, 2m/s ² from 20-55 Hz, 1 m/s ² from 55-200 Hz,
	Storage	Ambient temperature	-25 to 65°C (-13 to 149°F)
	Ambient humidity	5 to 95% (no condensation)	

11.3 Outline Dimensions

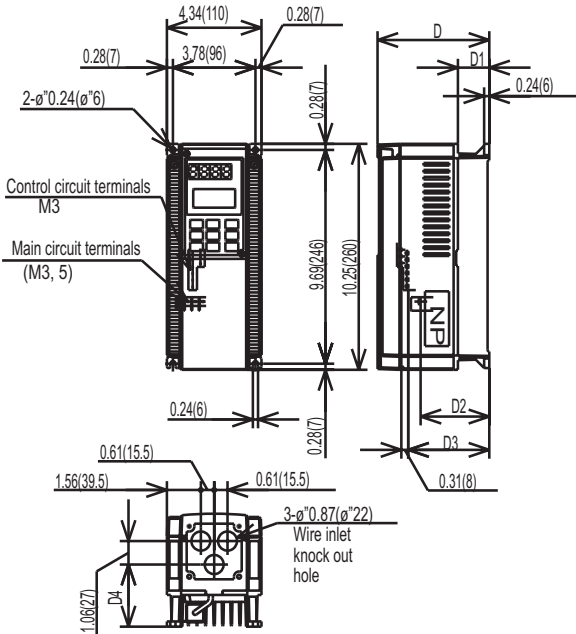

Type	D	D1	D2	D3	D4
1/4, 1/2 HP	5.12 (130)	1.44 (26.5)	3.15 (80)	3.7 (94)	2.81 (71.5)
1 HP	5.71 (145)	2.03 (51.5)	3.74 (95)	4.29 (109)	3.41 (86.5)

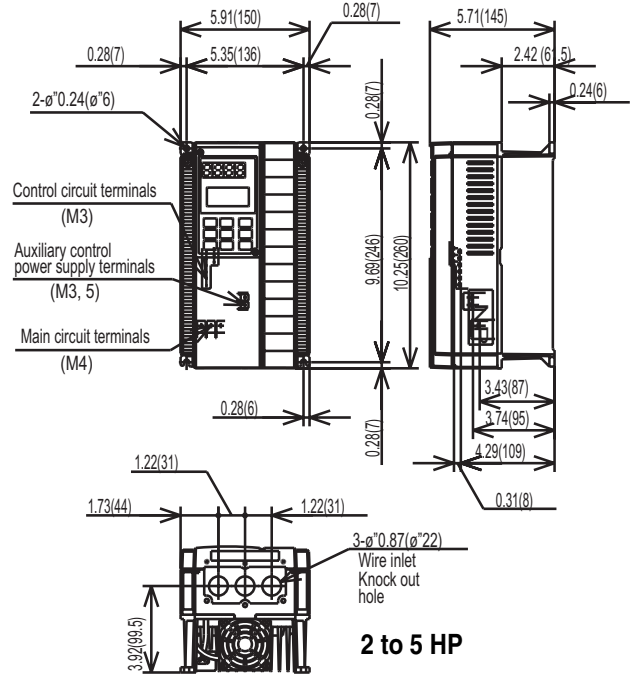

2 to 5 HP

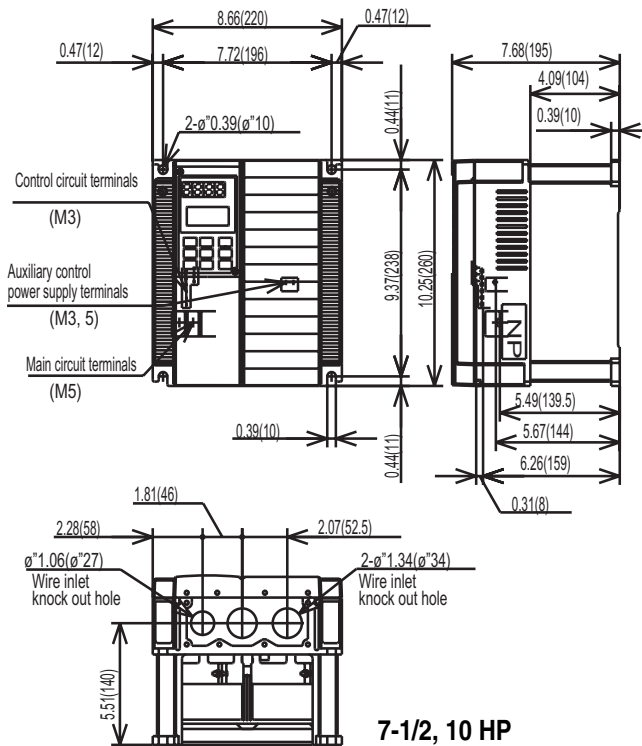

7-1/2, 10 HP

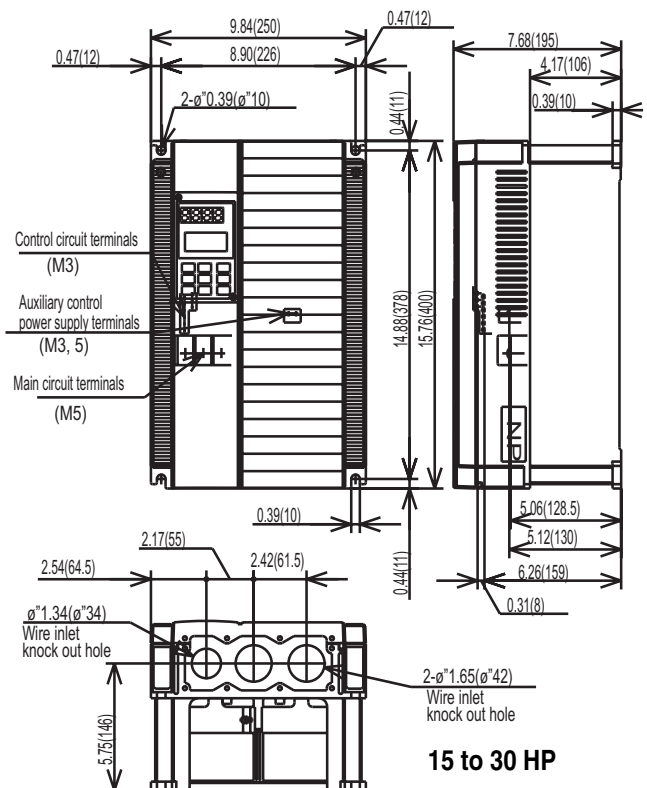

15 to 30 HP

11.3.1 Outline Dimensions NEMA 1

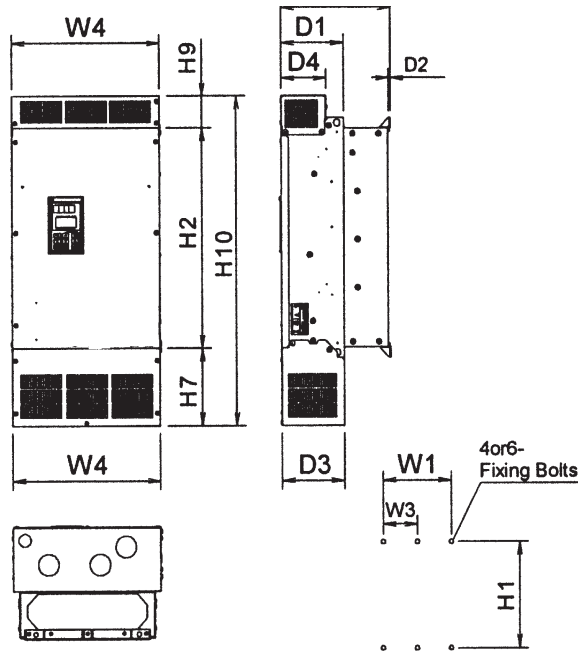

230V Series NEMA 1

HP	DIMENSIONS inches (mm)														Mtg. Bolts	Wt. Lb (kg)
	W1	W3	W4	H1	H2	H3	H6	H7	H9	H10	D	D2	D3	D4		
40	9.4 (240)	-	13.5 (342)	20.9 (530)	19.7 (500)	20.2 (512)	0.4 (9)	7.1 (180)	3 (75)	29.7 (755)	10 (255)	0.2 (4)	5.7 (145)	4.1 (105)	M8	70 (32)
50	10.8 (275)		14.9 (377)	23.4 (595)	22.2 (565)	22.7 (577)		7.9 (200)		33.1 (840)	10.6 (270)					86 (39)
60				28.3 (720)	27.2 (690)	27.6 (702)				38 (965)						106 (48)
75																110 (50)
100	16.9 (430)			21 (533)		27 (685)	27.4 (695)	0.5 (13)	11.1 (283)	3.3 (83)	41.3 (1050)	11.2 (285)				3.6 (91)
125	22.8 (580)	11.4 (290)	26.9 (683)	33.5 (850)	32.1 (815)	32.5 (825)		15.1 (383)		50.4 (1280)	14.2 (360)		8.7 (220)	6.5 (166)		282 (128)

460V Series NEMA 1

HP	DIMENSIONS inches (mm)														Mtg. Bolts	Wt. Lb (kg)
	W1	W3	W4	H1	H2	H3	H6	H7	H9	H10	D	D2	D3	D4		
40	9.4 (240)	-	13.5 (342)	20.9 (530)	19.7 (500)	20.2 (512)	0.4 (9)	7.1 (180)	3 (75)	29.7 (755)	10 (255)	0.2 (4)	5.7 (145)	4.1 (105)	M8	70 (32)
50	10.8 (275)		14.9 (377)								10.6 (270)					82 (37)
60				25.8 (655)	24.6 (625)	25.1 (637)					34.6 (880)					95 (43)
75																97 (44)
100					28.3 (720)	27.2 (690)	27.6 (702)		7.9 (200)		38 (965)					115 (52)
125	16.9 (430)		21 (533)	28 (710)	26.6 (675)	27 (685)	0.5 (13)	8.2 (208)	3.3 (83)		12.4 (315)		6.9 (175)	4.7 (121)	M12	174 (79)
150				38 (970)	37 (935)	37 (945)		13 (333)		53.1 (1350)	14.2 (360)		8.7 (220)	7 (166)		245 (111)
200																337 (153)
250																
300	22.8 (580)	11.4 (290)	26.9 (683)					15.1 (383)		55.1 (1400)						

Surface Mount

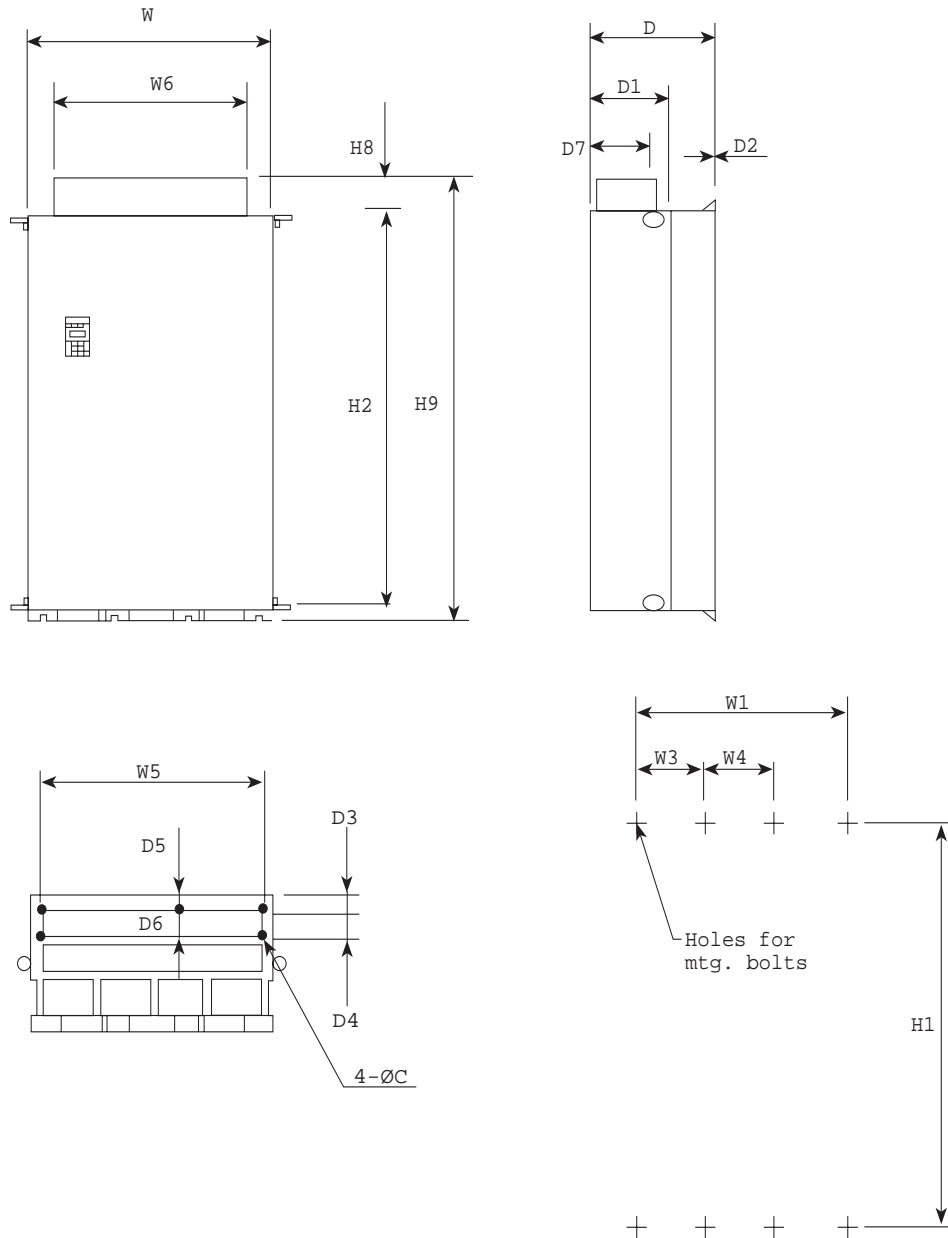

460V Series NEMA 1

HP	DIMENSIONS inches (mm)												
	W	W1	W3	W4	W5	W6	H1	H2	H4	H8	H9	D	D1
400	26.8	22.8	11.4	-	24.0	21.9	53.9	52.4	52.6	3.3	57.1	17.7	11.2
450	(680)	(580)	(290)		(610)	(555)	(1370)	(1330)	(1335)	(084)	(1450)	(450)	(285)
500	34.6	30.7	10.2	10.2	31.9	29.7							
600	(880)	(780)	(260)	(260)	(810)	(755)							

Hp	DIMENSIONS inches (mm)						Mtg. Bolts	Wt. Lb (kg)
	D2	D3	D4	D5	D6	D7		
400	0.3	2.0	3.9	1.4	4.5	8.7	M12	562
450	(6)	(50)	(100)	(35)	(115)	(220)		(255)
500								804
600								(365)

11.3.2 Outline Dimensions Open Type

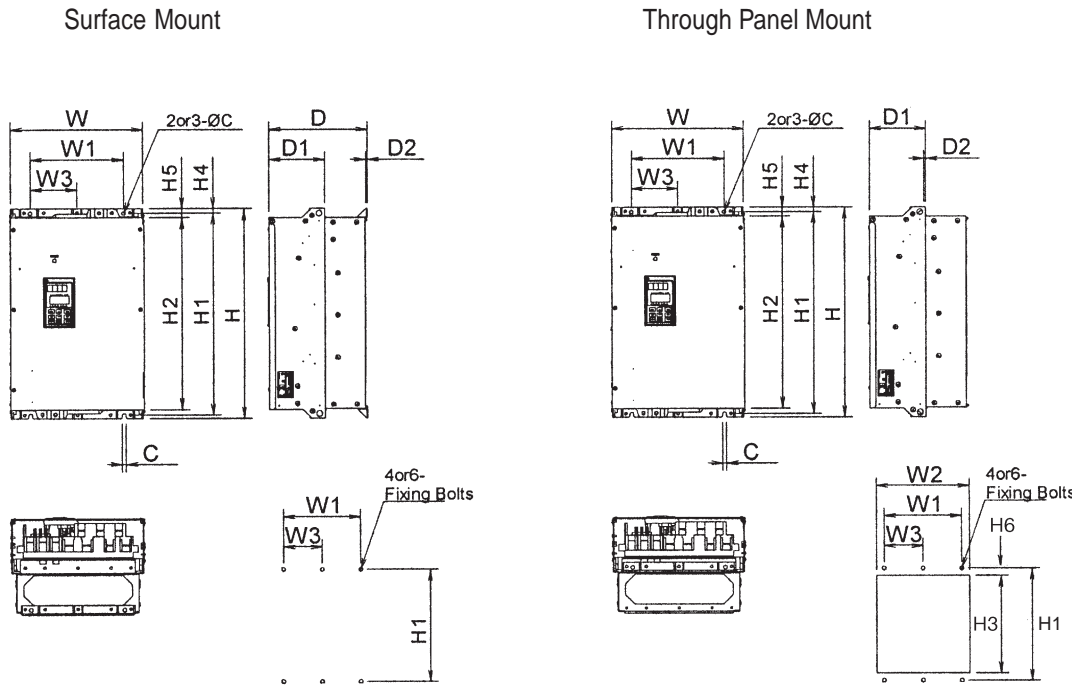

230V Series																	
Hp	DIMENSION Inch (mm)															Mtg. Bolts	Weight Lb (kg)
230V	W	W1	W2	W3	H	H1	H2	H3	H4	H5	H6	D	D1	D2	C		
40	13.4 (340)	9.4 (240)	12.8 (326)		21.7 (550)	20.9 (530)	19.7 (500)	20.2 (512)	0.5 (12)	1 (25)	0.4 (9)	10 (255)	5.7 (145)	0.2 (4)	0.4 (10)	M8	64 (29)
50	14.8 (375)	10.8 (275)	14.2 (361)		24.2 (615)	23.4 (595)	22.2 (565)	22.7 (577)				10.6 (270)					79 (36)
60					29.1 (740)	28.3 (720)	27.2 (690)	27.6 (702)									97 (44)
75																	101 (46)
100	20.9 (530)	16.9 (430)	20.1 (510)		29.5 (750)		27 (685)	27.4 (695)	0.6 (16)	1.3 (33)	0.5 (13)	11.2 (285)			0.6 (15)	M12	154 (70)
125	26.8 (680)	22.8 (580)	26 (660)		34.6 (880)	33.5 (850)	32.1 (815)	32.5 (825)				14.2 (360)	8.7 (220)				253 (115)
460V Series																	
Hp	DIMENSION Inch (mm)															Mtg. Bolts	Weight Lb (kg)
460V	W	W1	W2	W3	H	H1	H2	H3	H4	H5	H6	D	D1	D2	C		
40	13.4 (340)	9.4 (240)	12.8 (326)		21.7 (550)	20.9 (530)	19.7 (500)	20.2 (512)	0.5 (12)	1 (25)	0.4 (9)	10 (255)	5.7 (145)	0.2 (4)	0.4 (10)	M8	64 (29)
50	14.8 (375)	10.8 (275)	14.2 (361)									10.6 (270)					75 (34)
60					26.6 (675)	25.8 (655)	24.6 (625)	25.1 (637)									86 (39)
75																	88 (40)
100					29.1 (740)	28.3 (720)	27.2 (690)	27.6 (702)									106 (48)
125	20.9 (530)	16.9 (430)	20.1 (510)			28 (710)	26.6 (675)	27 (682)	0.6 (16)	1.3 (33)	0.5 (13)	12.4 (315)	6.9 (175)		0.6 (15)	M12	154 (70)
150												14.2 (360)	8.7 (220)				220 (100)
200					39.4 (1000)	38.2 (970)	36.8 (935)	37.2 (945)									308 (140)
250																	
300	26.8 (680)	22.8 (580)	26 (660)	11.4 (290)													
350																	

11.3.3 Outline Dimensions Open Type with NEMA 12 Heatsink

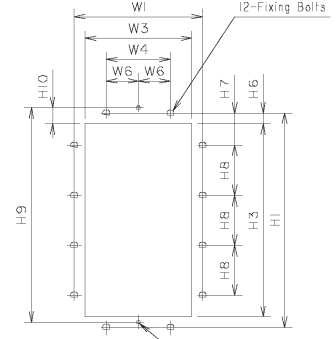
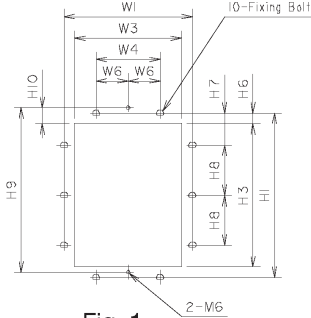
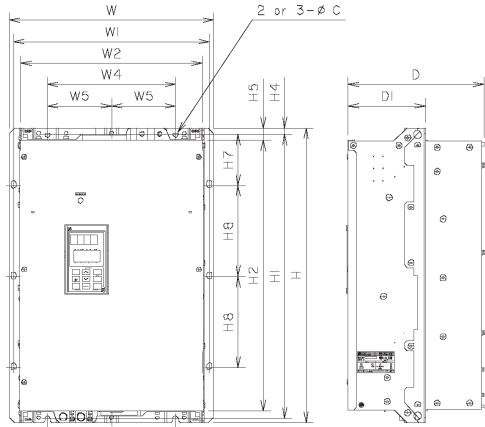

Fig. 1

Fig. 2

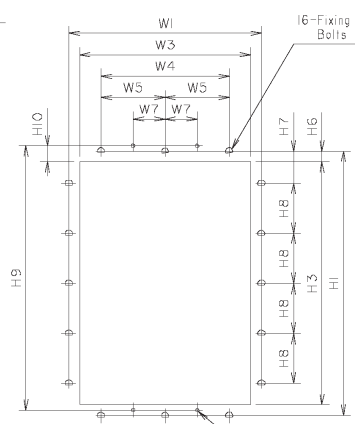
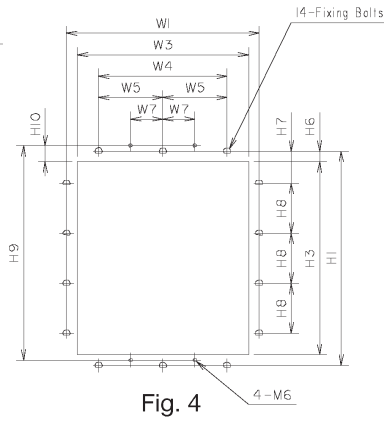
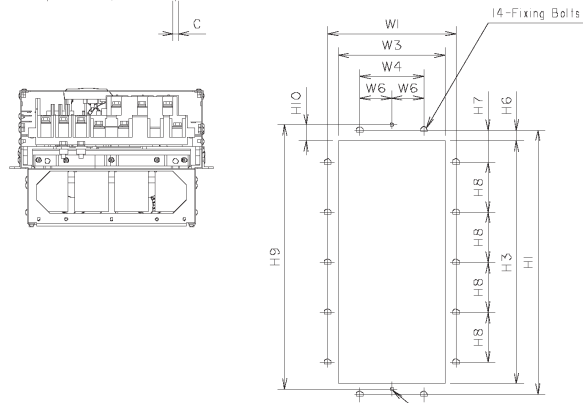

Fig. 3

Fig. 4

Fig. 5

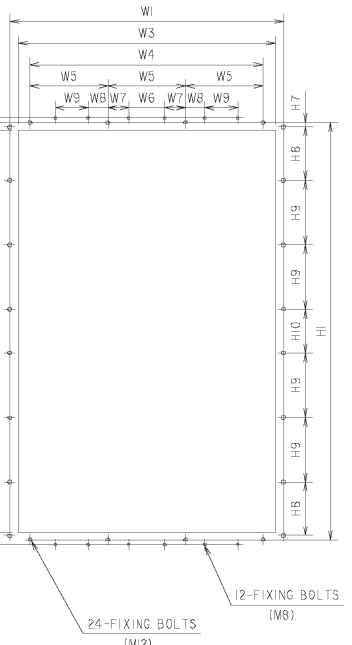
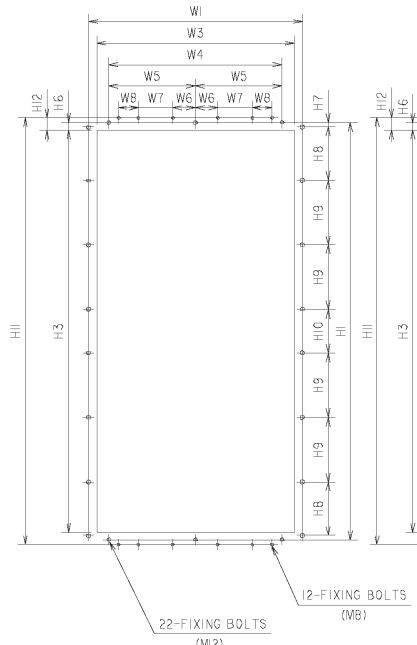
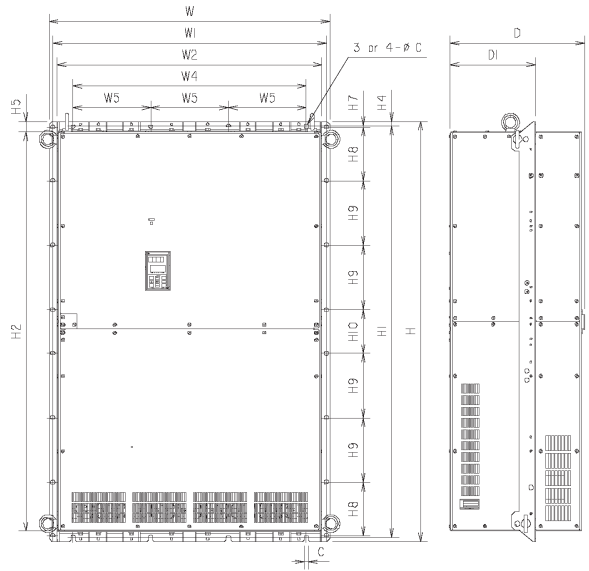
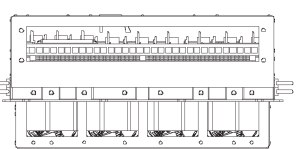

Fig. 6

Fig. 7



230 VAC Series

HP	DIMENSIONS Inch(mm)																					Fixing Bolts	Wt. Lb(kg)	Fig						
	W	W1	W2	W3	W4	W5	W6	W7	W8	W9	H	H1	H2	H3	H4	H5	H6	H7	H8	H9	H10				H11	H12	C	D	D1	
40	15.04 (382)	14.41 (366)	13.39 (340)	12.83 (326)	9.45 (240)		4.72 (120)				21.65 (550)	20.87 (530)	19.69 (500)	20.16 (512)				3.74 (95)		20.87 (530)					8.86 (225)		5.71	M6	66 (30)	1
50							5.41 (137.5)				24.21 (615)	23.43 (595)	22.24 (565)	22.72 (577)	0.47 (12)	0.98 (25)	0.35 (9)	1.67 (42.5)	6.69 (170)	23.43 (595)	0.43 (11)			0.4 (10)	10.63 (270)	5.71 (145)	M6 and M8	81 (37)	2	
60	16.42 (417)	15.79 (401)	14.76 (375)	14.21 (361)	10.83 (275)					29.13 (740)		27.17 (690)	27.64 (702)				4.13 (105)													99 (45)
75																														104 (47)
100	23.23 (590)	22.28 (566)	20.87 (530)	20.08 (510)	16.93 (430)		8.46 (215)				29.53 (750)		26.97 (685)	27.36 (695)	0.61 (15.5)	1.28 (32.5)	0.49 (12.5)	1.75 (44.5)	8.27 (210)		0.51 (13)			0.6 (15)	11.22 (285)	5.71 (145)	M6 and M12	161 (73)		
125	29.13 (740)	28.19 (716)	26.77 (680)	25.98 (660)	22.83 (580)	11.42 (290)		2.95 (75)			34.65 (880)	33.46 (850)	32.09 (815)	32.48 (825)				4.02 (102)	8.46 (215)	33.46 (850)									260 (118)	4

460 VAC Series

HP	DIMENSIONS Inch(mm)																					Fixing Bolts	Wt. Lb(kg)	Fig						
	W	W1	W2	W3	W4	W5	W6	W7	W8	W9	H	H1	H2	H3	H4	H5	H6	H7	H8	H9	H10				H11	H12	C	D	D1	
40	15.04 (382)	14.41 (366)	13.39 (340)	12.83 (326)	9.45 (240)		4.72 (120)				21.65 (550)	20.87 (530)	19.69 (500)	20.16 (512)				3.74 (95)		20.87 (530)					8.86 (225)		5.71	M6	66 (30)	1
50							5.41 (137.5)								0.47 (12)	0.98 (25)	0.35 (9)		6.69 (170)		0.43 (11)			0.4 (10)	10.63 (270)	5.71 (145)	M6 and M8	77 (35)	2	
60	16.42 (417)	15.79 (401)	14.76 (375)	14.21 (361)	10.83 (275)					26.57 (675)	25.79 (655)	24.61 (625)	25.08 (637)				2.85 (72.5)			25.79 (655)										88 (40)
75																														90 (41)
100										29.13 (740)	28.35 (720)	27.17 (690)	27.64 (702)				4.13 (105)			28.35 (720)										108 (49)
125										29.13 (740)	27.95 (710)	26.57 (675)	26.97 (685)		0.61 (15.5)	1.28 (32.5)	0.49 (12.5)	1.56 (39.5)	8.27 (210)	27.95 (710)		0.51 (13)		0.6 (15)	12.4 (315)	6.89 (175)	M6 and M12	161 (73)		
150																														
200	23.23 (590)	22.28 (566)	20.87 (530)	20.08 (510)	16.93 (430)		8.46 (215)				39.37 (1000)	38.19 (970)	36.81 (935)	37.20 (945)				2.15 (54.5)	8.46 (215)	38.19 (970)									229 (104)	3
250																														
300	29.13 (740)	28.19 (716)	26.77 (680)	25.98 (660)	22.83 (580)	11.42 (290)		2.95 (75)																					317 (144)	5
350																														
400	29.13 (740)	28.19 (716)	26.77 (680)	25.98 (660)	22.83 (580)	11.42 (290)	2.95 (75)	4.55 (115.5)	2.60 (66)		55.12 (1400)	53.94 (1370)	52.36 (1330)	52.76 (1340)	0.61 (15.5)	1.38 (35)	0.57 (14.5)	0.18 (4.5)	6.99 (177.5)	8.46 (215)	5.71 (145)	54.37 (1381)	0.81 (20.5)	0.59 (15)	17.72 (450)	11.22 (285)	M8 and M12	551 (250)	6	
450																														
500	37.01 (940)	36.06 (916)	34.65 (880)	33.86 (860)	30.71 (780)	10.24 (260)	4.72 (120)	2.76 (70)	2.56 (65)	4.33 (110)																			793 (360)	7
600																														

Keypad Mounting Hole (Panel Cutting)

Dimensions in inches (mm)

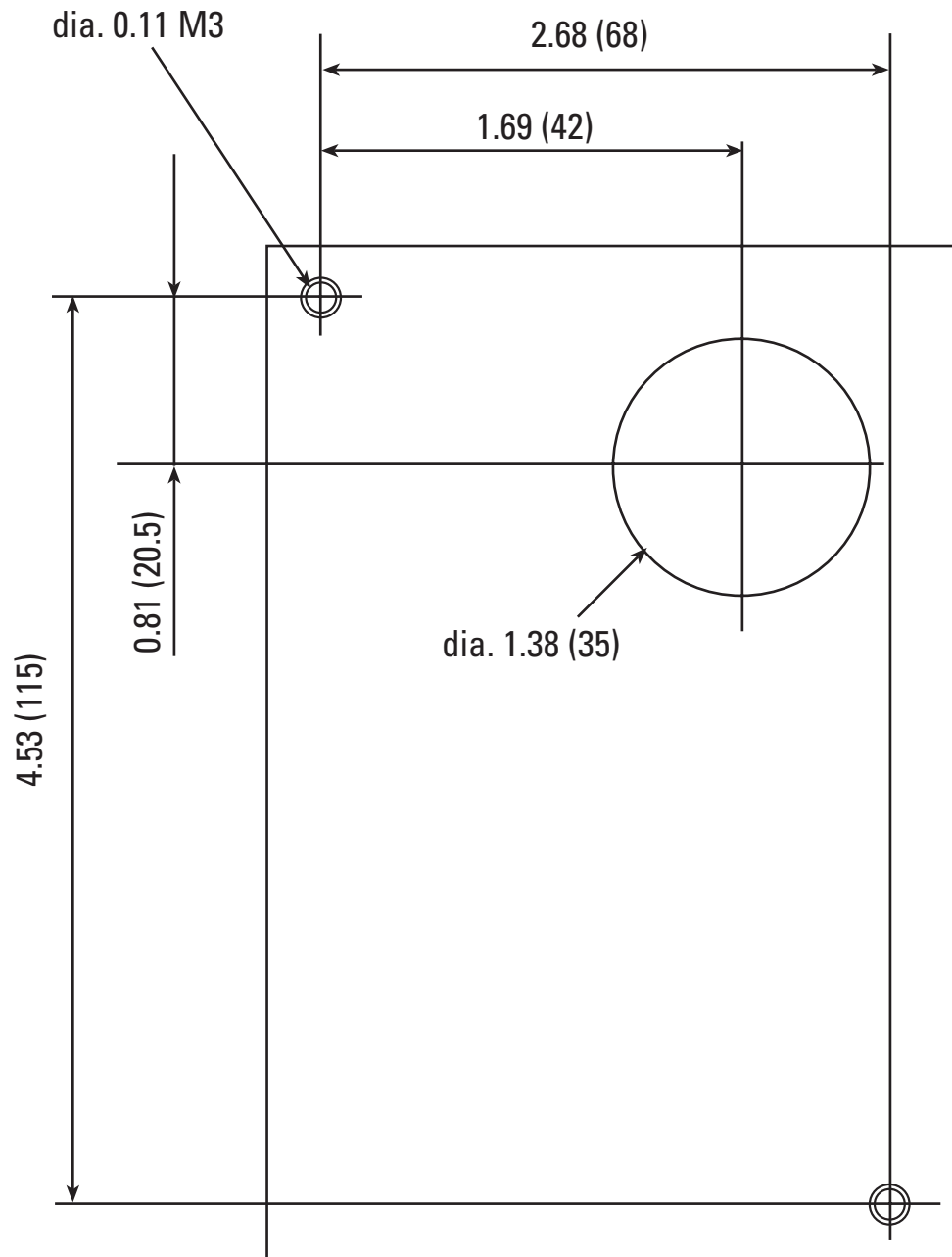

12. RS485 Modbus RTU Serial Communications

The serial interface supports operation, configuration and monitoring of drive functions through an EIA/RS485 connection. The serial interface is based on Modbus RTU protocol. This protocol allows the drive to function as an RTU slave on an industrial network.

12.1 Transmission Specification

Item	Specification
Physical level	EIA/RS485
Transmission distance	500m maximum
Number of nodes	32 total
Transmission speed	19200, 9600, 4800, 2400 [bits/s]
Transmission mode	Half duplex
Transmission protocol	Modbus RTU
Character code	Binary
Character length	8 bits
Error check	CRC

12.2 Connection

Connection method

Use shielded wire and connect to the control Terminals (DX-, DX+ and SD). A termination resistor should be added between the data lines on each end of the network. The value of the termination resistor depends on the characteristic impedance of the cable. A common value for termination resistors is 120 ohms.

Control terminals

Terminal Marking	Terminal Name	Function Description
DX+	RS485 communication data (+)	Input/output terminals for RS485 communication
DX-	RS485 communication data (-)	
SD	Cable shield	Electrically floating

12.3 Serial Interface Configuration

Drive function Codes H30 to H39 are used to configure the serial interface parameters, such as device address, baud rate and error response.

12.4 Modbus RTU Functions

The following RTU functions are supported. The maximum number of consecutive parameters for Functions 03 and 16 messages is 16.

Code	Description
03	Read Holding Registers (16 registers maximum)
06	Preset Single Register
16	Preset Multiple Registers (16 registers maximum)

12.5 Drive Function Code Access

All of the drive function codes are accessible through the RS485 serial interface. Drive function codes are mapped to RTU holding registers. A drive function code RTU address is 2 bytes in length. The high byte corresponds to a code that represents the drive parameter sort (F–M). The low byte corresponds to the drive parameter number within the sort (0 - 99).

Code	Sort	Name	Code	Sort	Name
0	F	Basic function	5	A	Motor 2 function
1	E	Terminal function	6	o	Option function
2	C	Control function	7	S	Command/function data
3	P	Motor 1 function	8	M	Monitor data
4	H	High level function			

For example, drive function Code M11, output current, is addressed as RTU parameter number 080B hexadecimal or 2059 decimal.

High Byte	Low Byte
Drive parameter sort code	Drive parameter number

12.6 Command and Monitor Data Registers

The command and monitor function codes are used to control the operation of the drive and monitor the status variables through the serial interface. The command and monitor function codes are not accessible from the drive keypad interface. Drive Parameter H30 and digital input signal LE must be enabled to operate the drive from the Modbus interface. If LE is not assigned to a digital input (X1-X9), the signal will default to ON.

Frequency Setting Registers

Address	Code	Name	Unit	Variable Range	Min. unit	Read/Write	Data Format
1793	S01	Frequency command	-	-20000 – 20000 (max. frequency at ± 20000)	1	R/W	2
1797	S05	Frequency command	Hz	0.00–400.00	0.01	R/W	5

Notes:

- 1) If both S01 and S05 are set, the drive will ignore the setting of S05.
- 2) A data setting that exceeds the setting range is possible, but the actual action will be limited by the drive configuration.

Operation Command Data Registers

Address	Code	Name	Unit	Variable Range	Min. unit	Read/Write	Data Format
1798	S06	Operation command	-	Refer to the data format [14]	-	R/W	14
1799	S07	Universal Do	-	Refer to the data format [15]	-	R/W	15
1804	S12	Universal Ao	-	-20000 – 20000 (100% output at ± 20000)	1	R/W	2

Notes:

- 1) Since X1–X9 are configurable input commands, it is necessary to set the functions by E01–E09.
- 2) The alarm reset is executed when the RST signal changes from ON to OFF, even if there are no alarms.
- 3) Universal Do is a function that utilizes the drive’s digital outputs via communication.

Function Data Registers

Address	Code	Name	Unit	Variable range	Min. unit	Read/Write	Data Format
1800	S08	Acceleration time F07	s	0.1–3600.0	0.1	R/W	3
1801	S09	Deceleration time F08	s	0.1–3600.0	0.1	R/W	3
1802	S10	Torque limit level 1 (driving) F40	%	-20.00 – 200.00, 999	1	R/W	5
1803	S11	Torque limit level 2 (braking) F41	%	0.00, 20.00 – 200.00, 999	1	R/W	5

Notes:

- 1) The writing of data out of range is treated as out of range error.
- 2) Use a value of 7FFF_h to enter 999 for torque limit functions.

Monitoring Parameter Registers

Address	Code	Description	Unit	Range	Min. unit	Read / Write	Data Format
2049	M01	Frequency command (final command)	-	- 20000–20000 (max. frequency at \pm 20000)	1	R	2
2053	M05	Frequency command (final command)	Hz	0–400.00	0.01	R	5
2054	M06	Actual frequency	-	- 20000–20000 (max. frequency at \pm 20000)	1	R	2
2055	M07	Actual torque value	%	- 200.00–200.00	0.01	R	6
2056	M08	Torque current	%	- 200.00–200.00	0.01	R	6
2057	M09	Output frequency	Hz	0.00–400.00	0.01	R	5
2058	M10	Motor output (input electric power)	%	0.00–200.00	0.01	R	5
2059	M11	Output current r. m. s.	%	0.00–200.00 drive rating at 100.00)	0.01	R	5
2060	M12	Output voltage r. m. s.	V	0.0–600.0	1	R	3
2061	M13	Operation command (final command)	-	Refer to data format [14]	-	R	14
2062	M14	Operating state	-	Refer to data format [16]	-	R	16
2063	M15	Universal output terminal data	-	Refer to data format [15]	-	R	15
2064	M16	Fault memory 0	-	Refer to data format [10]	-	R	10
2065	M17	Fault memory 1	-				10
2066	M18	Fault memory 2	-				10
2067	M19	Fault memory 3	-				10
2068	M20	Integrated operating time	h	0–65535	1	R	1
2069	M21	DC link voltage	V	0–1000	1	R	1
2071	M23	Type code	-	Refer to data format [17]	-	R	17
2072	M24	Drive capacity code	-	Refer to data format [11]	-	R	11
2073	M25	ROM version	-	0–64999	1	R	1
2074	M26	Transmission error processing code	-	Refer to data format [20]	-	R	20
2075	M27	Frequency command at alarm (final command)	-	- 20000–20000 (max. frequency at \pm 20000)	1	R	2
2079	M31	Frequency command at alarm (final command)	Hz	0–400.00	0.01	R	5
2080	M32	Actual frequency at alarm	-	- 20000–20000 (max. frequency at \pm 20000)	1	R	2
2081	M33	Actual torque at alarm	%	- 200.00 – 200.00	0.01	R	6
2082	M34	Torque current at alarm	%	- 200.00 – 200.00	0.01	R	6
2083	M35	Output frequency at alarm	Hz	0.00 – 400.	0.01	R	5
2084	M36	Motor output at alarm (input power)	%	0.00–200.00	0.01	R	5
2085	M37	Output current r.m.s. at alarm	%	0.00 – 200.00 (drive rating at 100.00)	0.01	R	5
2086	M38	Output voltage effective value at alarm	V	0.0 – 600.0	1	R	3
2087	M39	Operation command at alarm	-	Refer to data format [14]	-	R	14
2088	M40	Operating state at alarm	-	Refer to data format [16]	-	R	16
2089	M41	Universal output terminal data at alarm	-	Refer to data format [15]	-	R	15
2090	M42	Integrated operation time at alarm	h	0–65535	1	R	1
2091	M43	DC link voltage at alarm	V	0–1000	1	R	1
2092	M44	Drive internal air temp. at alarm	°C	0–120	1	R	1
2093	M45	Cooling fin temp. at alarm	°C	0–120	1	R	1
2094	M46	Life of main circuit capacitor.	%	0.0–100.0	0.1	R	3
2095	M47	Life of printed circuit board capacitor.	h	0–65535	1	R	1
2096	M48	Life of cooling fan.	h	0–65535	1	R	1

Code	Description	Code	Description
0	No alarm	--	Overheat, DB resistor
1	Overcurrent, during acceleration (INV output)	OC1	Overload, motor 1
2	Overcurrent, during deceleration (INV output)	OC2	Overload, motor 2
3	Overcurrent, during steady state operation (INV output)	OC3	Overload, drive
5	Ground fault	EF	Overspeed
6	Overvoltage, during acceleration	OU1	PG wire break
7	Over voltage, during deceleration	OU2	Memory error
8	Overvoltage, during steady state operation	OU3	Keypad error
10	DC undervoltage	LU	CPU error
11	Power supply open phase	Lin	Option comm error
14	Blown DC fuse	FUS	Option error
16	Output wiring error	Er7	PL error
17	Overheat, heat sink, inverter	OH1	Output wiring error
18	Overheat, outside thermal	OH2	RS485 comm error
19	Overheat, unit inside temp	OH3	

Data format [11] Capacity code

Code	Capacity (HP)	Code	Capacity (HP)	Code	Capacity (HP)
7	0.07 (spare)	2000	20	17500	175
15	0.15 (spare)	2500	25	20000	200
25	0.25	3000	30	25000	250
50	0.5	4000	40	30000	300
100	1	5000	50	35000	350
200	2	6000	60	40000	400
300	3	7500	75	45000	450
500	5	10000	100	50000	500
750	7.5	12500	125	60600	600
1000	10	15000	150	60700	700
1500	15			60800	800

Data format [12] Index data (ACC/DEC time, display coefficient)

15	14	13	12	11	10	9	8	7	6	5	4	3	2	1	0
Polarity	0	0	0	Index portion			Data portion								

1: Negative (-)	0: 0.01	X	001-999	(0.00-9.99)
0: Positive (+),	1: 0.1	X	00-999	(10.0-99.9)
	2: 1	X	100-999	(100-999)
	3: 10	X	100-999	(1000-9990)

Example: If F07 (acceleration time 1) = 20.0 seconds

$$10.0 < 20 < 99.9 \quad \text{index} = 1$$

$$20.0 = 0.1 \times 200 \quad 0400_H + 00C8_H = 04C8_H$$

Data format [13] Pattern operation

15	14	13	12	11	10	9	8	7	6	5	4	3	2	1	0
Direction of rotation	0	Time		Index portion	Data portion										

	0: 1 st ACC/DEC time	0: 0.01	X		001-999	(0.00-9.99)
0: FWD	1: 2 nd ACC/DEC time	1: 0.1	X		100-999	(10.0-99.9)
1: REV	2: 3 rd ACC/DEC time	2: 1	X		100-999	(100-999)
	3: 4 th ACC/DEC time	3: 10	X		100-999	(1000-9990)

Example: If C22 (Stage1) = 10.0 seconds R2 (10 seconds, reverse rotation, acceleration time 2/deceleration time 2)
 Since $10.0 = 0.1 \times 100 > 9000_H + 0400_H + 0064_H = 9464_H$

Data format [14] Operation command

15	14	13	12	11	10	9	8	7	6	5	4	3	2	1	0
RST	0	0	0	0	X9	X8	X7	X6	X5	X4	X3	X2	X1	REV	FWD

(All bit are ON by 1)
 Example: If S06 (operation command) = FWD, X1 and X5 = ON
 $0000\ 0000\ 0100\ 0101_b = 0045_H$

Data format [15] Universal output terminal

15	14	13	12	11	10	9	8	7	6	5	4	3	2	1	0
0	0	0	0	0	0	0	0	0	0	0	Y5	Y4	Y3	Y2	Y1

(All bit are ON by 1)
 Example: If M15 (Universal output terminal) = Y1 and Y5 = ON
 $0000\ 0000\ 0001\ 0001_b = 0011_H$

Data format [16] Operating state

15	14	13	12	11	10	9	8	7	6	5	4	3	2	1	0
BUSY	WR	RL	ALM	DEC	ACC	IL	VL	TL	NUV	BRK	INT	EXT	REV	FWD	

(All bit are ON or active by 1)

FWD:	Forward operation	IL:	Current limiting
REV:0:	Reverse operation	ACC:	Under acceleration
EXT:	DC braking active (or pre-excitation)	DEC:	Under deceleration
INT:	No Output	ALM:	Drive fault
BRK:	Braking active	RL:	Transmission valid
NUV:	DC link voltage is established (undervoltage at 0)	WR:	Function writing privilege
TL:	Torque limiting	0:	Keypad panel
VL:	Voltage limiting	1:	RS485
		2:	Fieldbus (option)
		BUSY:	Processing data write

Data format [17] Type code

15	14	13	12	11	10	9	8	7	6	5	4	3	2	1	0
Type				Generation				Series				Voltage series			

Code	Type	Generation	Series	Voltage series
1				
2				
3				230V three phase
4				460V three phase
5	-	-	USA	575V three phase
6				

Data format [18] Code setting (1–4 figures)

15	14	13	12	11	10	9	8	7	6	5	4	3	2	1	0
Data 4				Data 3				Data 2				Data 1			

Data format [19] Amperage value Decimal data (positive): Min. unit 0.01 for drive capacity not more than 30HP Min unit 0.01 for not less than 40HP

Example: If F11 (electronics thermal overload relay 1 level) = 107.0A (40HP)

$$107.0 \times 10 = 1070 = 042E_H$$

If F11 (electronics thermal overload relay 1 level) = 3.60A (1HP)

$$\text{Since } 3.60 \times 100 = 360 = 0168_H$$

Data format [20] Transmission error code

Code	Description	Code	Description
1	FC (function code) error	71	CRC error (no response)
2	Illegal address	72	Parity error (no response)
3	Illegal address (Data range error)	73	Other errors (no response) -Framing error -Overrun error -Buffer full error
7	NAK -Priority for comm -No privilege for writing error -Forbidden writing error		

Data format [21]

Auto tuning

15	14	13	12	11	10	9	8	7	6	5	4	3	2	1	0
0	0	0	0	0	0	REV	FWD								

0: Without forward rotation command
 1: With forward rotation command
 0: Without reverse rotation command
 1: With reverse rotation command

Example: If P04 (motor 1 auto - tuning) = 1: Forward rotation
 0000 0001 0000 0001_b = 0101_H

12-7 Communication Errors

Exception Response

When the drive receives a message that does not contain communication errors, but the message can not be processed, the drive will return an exception response. The exception response contains an error sub-code in the data field that represents the problem.

Exception Response Errors

Sub-Code	Name	Causes
1	Illegal Function	Received RTU Function other than 03, 06 or 16
2	Illegal Data Address	<ul style="list-style-type: none"> The starting parameter address is an unused drive parameter. The starting parameter address plus the offset refers to drive parameter greater than the last parameter in a Function Code sort. The number of registers is greater than 16.
3	Illegal Data Value	Data contains an out of range value for a drive parameter
7	Negative Acknowledge	<ul style="list-style-type: none"> Requested data cannot be changed while the drive is running. The drive parameter function is owned by the network interface option card and cannot be changed.

Communication errors

Communication errors occur when the drive receives an invalid message. The drive will not return a response to a communication error. A code that represents the last communication error is stored in drive Parameter M26. Typical communication message errors include parity, framing, and CRC errors.

13. Options

13.1 Built-in Options

The drive supports two internally mounted cards. One option card is mounted under the main cover (Location A) and the other option card is mounted in a special adapter under the keypad (Location B). Only one card can be mounted in these locations. There are two different types of option cards, Type 1 and Type 2. You cannot use two Type 1 or Two Type 2 cards, but you can mix any combination of Type 1 and Type 2 provided you only have one option per mounting location. Each option card must be mounted in the designated location. The chart below lists the option card, their types, and their mounting locations.

Name	Type	Loc	2nd Option Type/Loc	Function
Relay output card	1	A	2/B	<ul style="list-style-type: none"> Relay output card The transistor output from the drive control output Terminals Y1 and Y4 are converted to the relay output (1SPDT).
Digital interface card	2	A	None	<ul style="list-style-type: none"> Frequency setting by binary code (maximum 16 bits) Monitoring (8 bits) of frequency, output current, and output voltage
Analog interface card	2	A	None	<ul style="list-style-type: none"> Auxiliary input for analog frequency setting (0 to +/-10 V) Monitoring of drive output frequency, current, and torque in analog voltage, analog output 0-10 VDC and 4-20mA
PG Feedback Card	1	A	2/B	<ul style="list-style-type: none"> This will enable vector control by pulse generator feedback signal Proportional operation, tuning operation (12/15 V; A, B Signal)
PG Feedback Card	1	A	2/B	<ul style="list-style-type: none"> This will enable vector control by pulse generator feedback signal Proportional operation, tuning operation (5V; A, not A, B, not B Signals)
Synchronized operation card	1	A	2/B	<ul style="list-style-type: none"> Two motors are driven synchronously
Interface card	1	A	2/B	<ul style="list-style-type: none"> 115 VAC Control input, an isolation amplifier, relay output, PG encoder, analog output 4-20mA
Communication card	2	B	1/A	<ul style="list-style-type: none"> Serial communication card for LonWorks
Communication card	2	B	1/A	<ul style="list-style-type: none"> Serial communication card for Profibus-DP
Communication card	2	B	1/A	<ul style="list-style-type: none"> Serial communication card for Device Net
Communication card	2	B	1/A	<ul style="list-style-type: none"> Serial communication card for CAN
Communication card	2	B	1/A	<ul style="list-style-type: none"> Serial communication card for Modbus plus
Communication card	2	B	1/A	<ul style="list-style-type: none"> Serial communication card for Interbus-S
Communication card	2	B	1/A	<ul style="list-style-type: none"> Serial communication card for Genius

ACE40UG

Name	Digital I/O interface card	
Type		
Function	4 digital inputs: Binary code input of max. 16 bits or BCD input (Sink/Source changeable) 3 digital outputs: Binary code output of max. 8 bits.	
Specifications	Input	Digital signal input (4 points) by short-circuiting terminals L1, L16 and M1 <Sink> ON operation current: 4.5mA max. OFF operation voltage: 27V max. <Source> ON operation current: 4.5mA max. OFF operation voltage: 27V max. Related function code: o19, o20
	Output	Digital signal output (3 points) by short-circuiting terminals between O1 to O6, and M2 <Sink> ON operation current: 50mA max. OFF operation voltage: 27V max. <Source> ON operation current: -50mA max. OFF operation voltage: 27V max. Related function code: o21
	Power Source	+24 VDC (3.2mA x 4 + 12.8mA)

Connection diagram

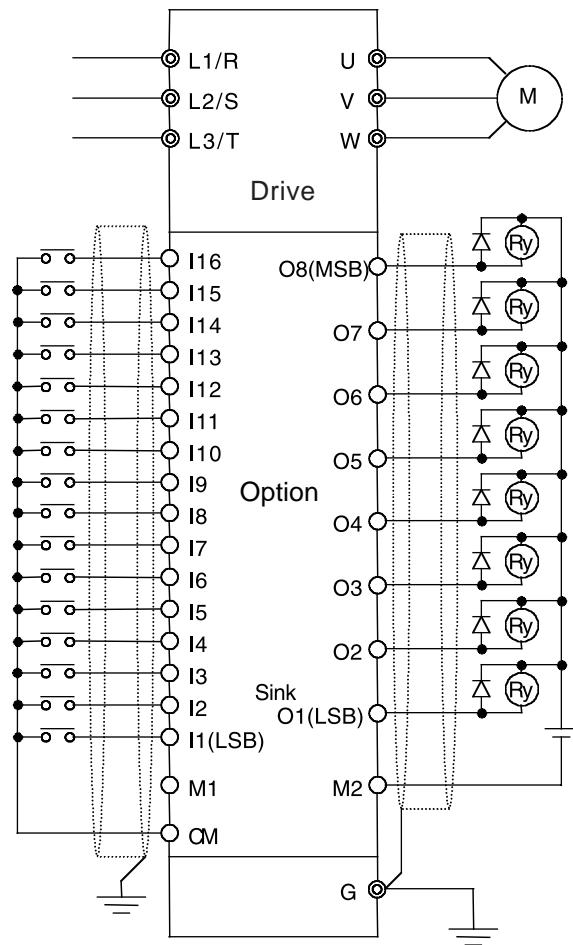

Remarks

Name	PG feedback card		
Type			
Function	To perform speed control by detecting motor rotating speed using a pulse generator.		
Specifications	Control	Speed Control Range	3 to 3600 [rpm] (for 4-pole motor)
		Speed Control Accuracy	-0.02%
		Starting Torque	150% zero-speed (at ZERO signal ON) short time
		Maximum number of Input Pulse	100 (kp/s)
Applicable encoder (generator)	Output Pulse	20 to 3000P/R (A, not A, B, not B)	
	PG Power Supply	+5 VDC - 10%/200mA	
	Maximum Response Frequency	100kHz	
Input Terminal	PI	Pg External Power Supply Input	
	PO	PG Power Supply Output	
	CM	Common	
	YA	Input Feedback PG Phase A (+) Pulse	
	*YA	Input Feedback PG Phase A (-) Pulse	
	YB	Input Feedback PG Phase B (+) Pulse	
	*YB	Input Feedback PG Phase B (-) Pulse	
Power Source	Internal Power Supply	+5 VDC - 10%/200mA ¹	
	External Power Supply	5 VDC - 10%	
	¹ Please use an external power supply when you exceed 200mA.		

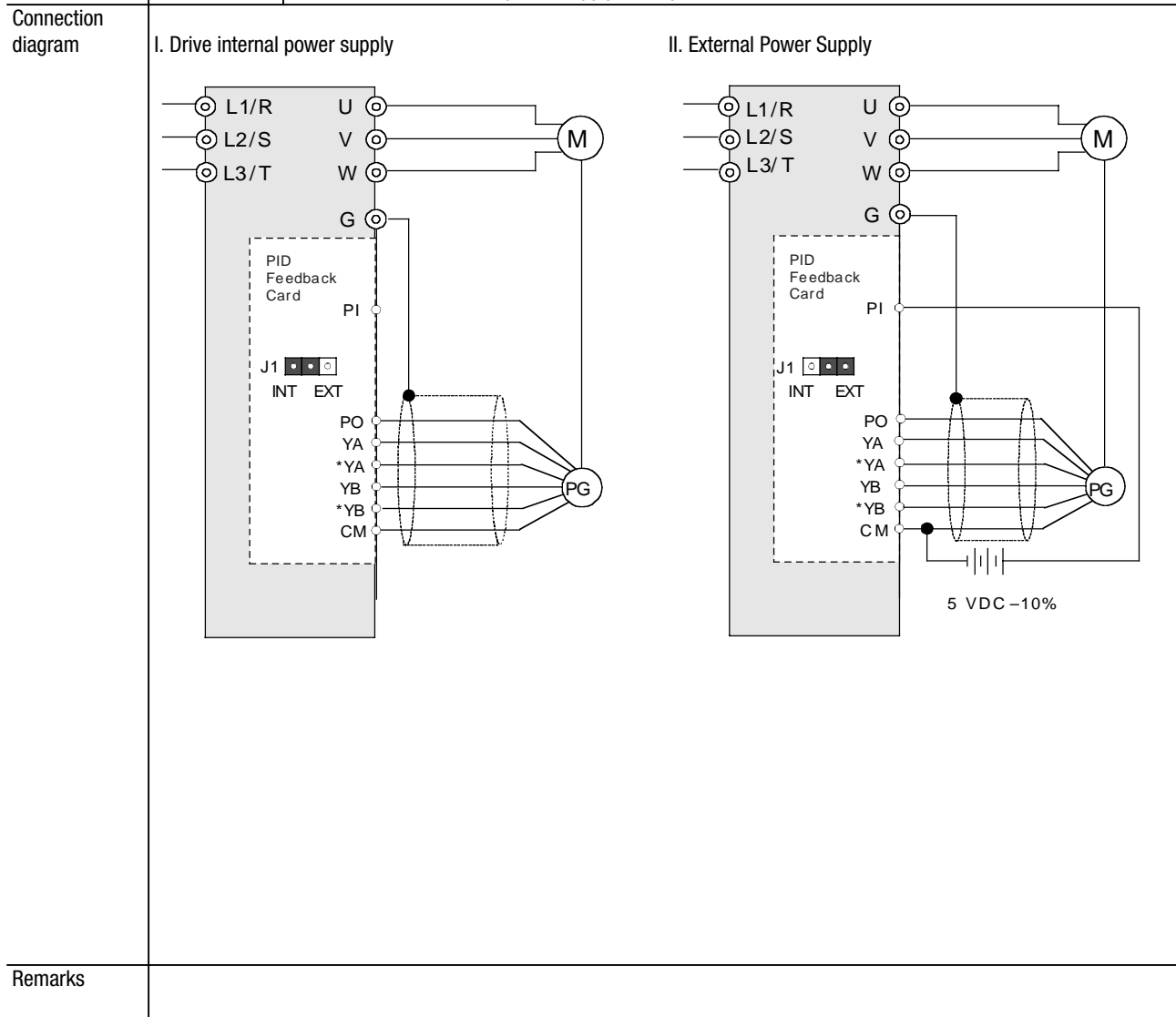

Name	PG feedback card		
Type			
Function	To perform speed control by detecting motor rotating speed using a pulse generator.		
Specifications	Control	Speed Control Range	1: 1200 (3 to 3600 rpm)
		Maximum speed	3600 rpm (120 Hz)
		Speed Control accuracy	±0.02%
		Speed Control response	40 Hz
	Applicable encoder (generator)	<ul style="list-style-type: none"> No. of output pulses: 100 to 3000P/R A/B phase (incremental) Maximum response frequency: 100kHz Pulse output method: Totem pole / open collector. Output current 7mA or more. 	
Input terminal	YA, YB, CM	Connect A- and B-phase output signal from pulse generator on feedback side.	
	YZ, CM	Connect Z-phase output signal from pulse generator on feedback side. When the pulse generator does not have Z-phase, these terminals need not be connected.	
Output	None		
Power source	<ul style="list-style-type: none"> Internal power source: +15 VDC ± 10% 120mA, + 12 VDC ± 10% 120mA (Changeable on PC board¹) External power source: +12 VDC (-10%) to +15 VDC (+1-%) / 300mA or less² (Terminal P1, CM). 		
	¹ Use external power source when more than one PG feedback cards are used and the total input current exceeds 120mA. ² Be sure the power source matches the specifications of the applied pulse generator.		

Connection diagram	<p>I. Drive internal power supply</p>	
	<p>II. External Power Supply</p> <p style="text-align: center;">The Jumper J2 can be connected to the 12V or 15V side.</p>	
Remarks	Terminals XA, XB and XZ are not in use.	

Name	Synochronized operation card	
Type		
Function	To perform position control by pulse train input, synchronize operator of 3 motors (wait-and-synchronize operation, simultaneous-start-and synchronize operation, and proportional speed ration operation)	
Specifications	Control	Speed Control Range 1: 1200 (3 to 3600 rpm) Maximum speed 3600 rpm (120 Hz) Speed Control accuracy ±0.02% Speed Control response 40 Hz
	Applicable encoder (generator)	<ul style="list-style-type: none"> No. of output pulses: 20 to 3000P/R A/B phase (incremental) Maximum response frequency: 100kHz Wiring length: 100m (totem pole) / 20 (Open collector) Pulse output method: Totem pole / open collector, output current 7mA or more.
	Input terminal	XA, XB, CM Connect A- and B-phase output signal of master rotary encoder XZ, CM Connect Z-phase output signal of master rotary encoder YA, YB, CM Connect A- and B-phase output signal of feedback or master rotary encoder YZ, CM Connect Z-phase output signal of master rotary encoder
	Output	None
Power source	¹ Use external power source when more than one PG feedback cards are used and the total input current exceeds 120mA. ² Be sure the power source matches the specifications of the applied rotary encoder.	

Connection diagram

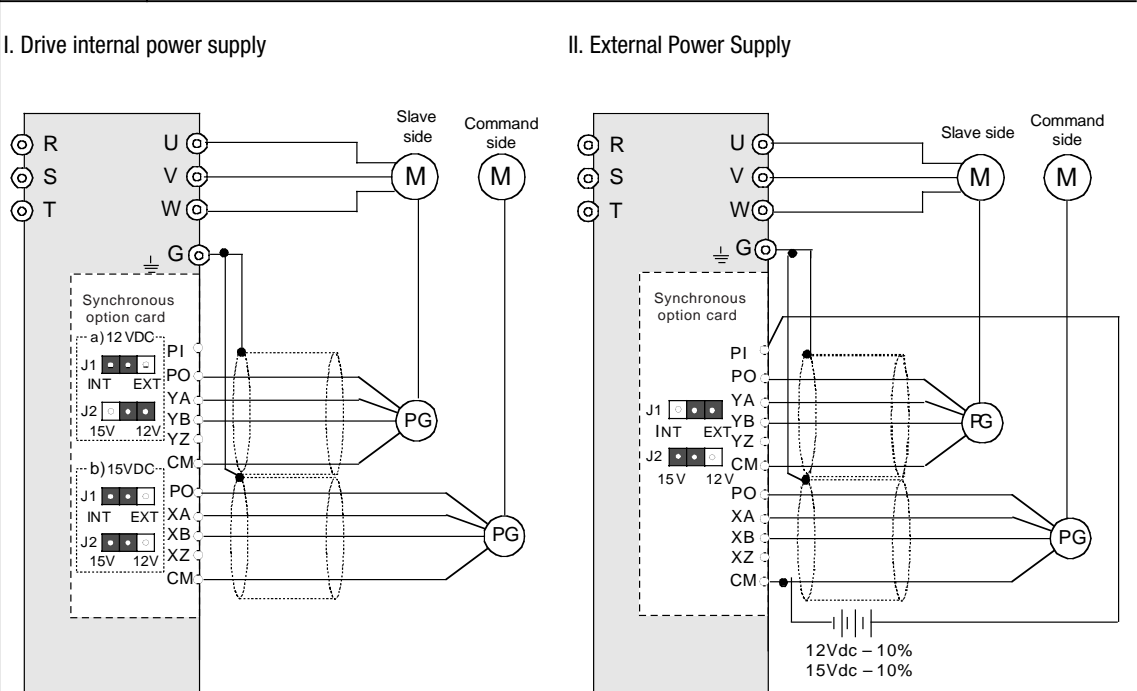

* Pin J2 may be connected on either the 12V or 15V side.

The above diagrams are used when the drive internal power source is used.
 When using external power source, perform connections similar to the above connection, be referring to footnote²

Remarks

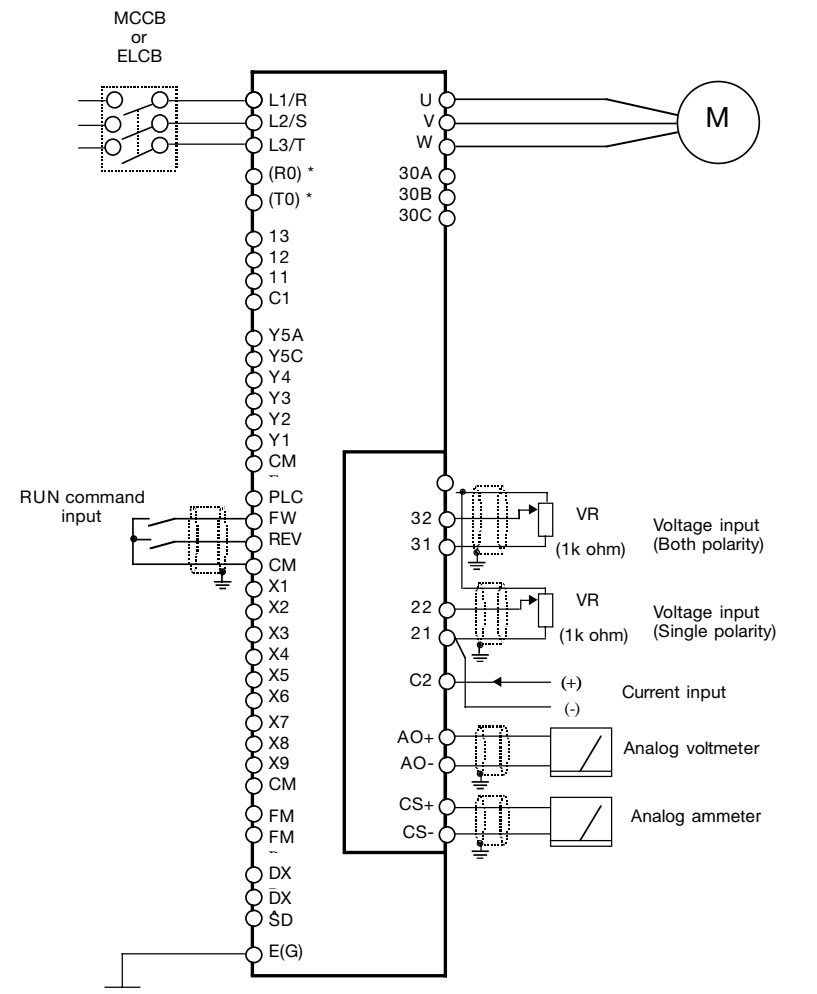
Name	Analog I/O Interface Card	
Type		
Function	<p>3 analog inputs (2 voltage inputs and 1 current input): Torque limiting value (driving, braking), frequency setting, ratio setting can be input, respectively.</p> <p>2 analog outputs (1 voltage output and 1 current output): 11 types of data can be output.</p>	
Specifications	Input	<p>Analog signal input (3 points) 32 and 31, 22 and 21, C2 and 21.</p> <p>Terminal 32: Voltage input (both sides): 0 to -10 VDC / 0 to -100%, input impedance: 22k ohms.</p> <p>Terminal 22: Voltage input (both sides): 0 to +10 VDC / 0 to +100%, input impedance: 22k ohms.</p> <p>Terminal C2: Current input: 4 to + 20mADC / 0 to +100%, input impedance: 250k ohms.</p> <p>For voltage input, power supply terminal for variable resistor (P10) should be connected.</p> <p>Related Function Code o22</p>
	Output	<p>Analog signal input (2 points) between AO+ and AO-, CS+ and CS-</p> <p>Terminal AO+: Voltage output: 0 to -10 VDC, for maximum 2 voltmeters, input impedance: 10k ohms</p> <p>Terminal AO-: Voltage output common.</p> <p>Terminal CS+: Current output: 4 to 20mA dc, maximum 500 ohms</p> <p>Terminal CS-: Current output common</p> <p>(Terminal CS- is isolated from Terminals 21, 31 and AO-)</p> <p>Related Function Code o23</p>
Connection diagram	 <p style="text-align: center;">* Terminals [R0] and [T0] are not provided for 1.0 HP or smaller.</p>	
Remarks		

Name	Relay Output Card	
Type		
Function	¥ Includes 4 relay output circuits ¥ Converts transistor output signals from drive control output Terminals Y1 to Y4 to relay (1SPDT) output signals.	
Specifications	Input	None
	Output	Four-channel contact (12 terminals from Y1A to Y4C) 250 VAC, 0.3A, ocs dia. = 0.3
	Power source	The power source to drive the relay card is supplied from the drive.

Connection diagram

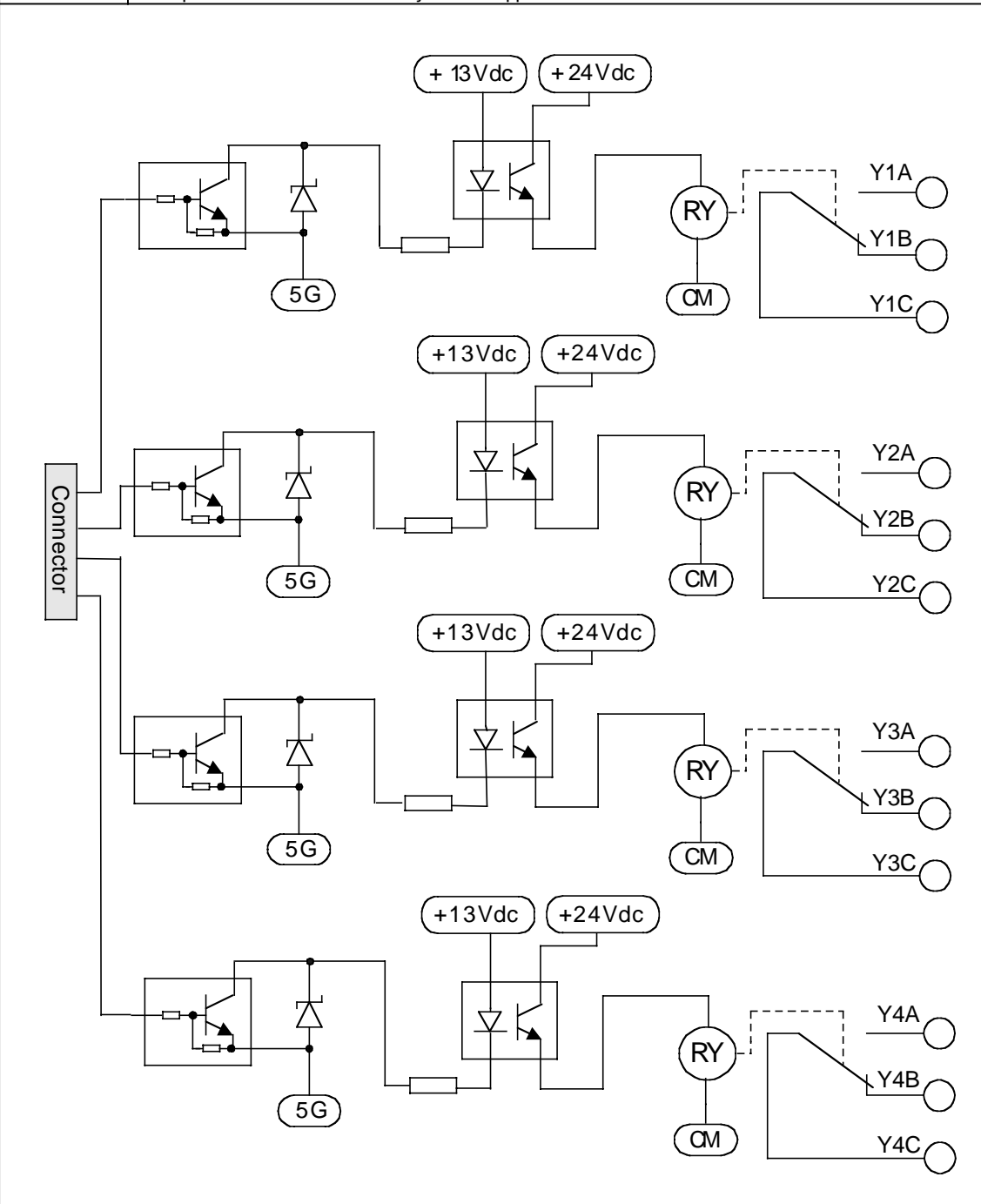

Remarks

14. Electromagnetic Compatibility (EMC)

14.1 General

In accordance with the provisions described in the European Commission Guidelines Document on Council Directive 89/336/EEC, these drives are classified as "Complex Components."

Classification as "Complex Components" allows a product to be treated as an "apparatus," and thus permits compliance with the essential requirements of the EMC Directive to be demonstrated to both an integrator of ACE 40 Series drives and to his customer or the installer and the user.

The ACE 40 may be supplied 'CE-marked', signifying compliance with EC Directive 89/336/EEC when fitted with specified filter units installed and earthed in accordance with this sheet.

This Specification requires the following performance criteria to be met.

EMC product standard EN61800-13/1997

Immunity: Second environment (Industrial environment)
Emission: First environment (Domestic environment)

Finally, it is the customer's responsibility to check whether the equipment conforms to EMC directive.

14.2 Recommended Installation Instructions

It is necessary that to conform to the EMC Directive, these instructions be followed.

Follow the usual safety procedures when working with electrical equipment. All electrical connections to the filter, drive and motor must be made by a qualified electrical technician.

- 1) Use the correct filter according to the table on page 14-2.
- 2) Install the drive and filter in the electrically shielded metal wiring cabinet.
- 3) The back panel of the wiring cabinet should be prepared for the mounting dimensions of the filter. Care should be taken to remove any paint, etc., from the mounting holes and face area of the panel. This will ensure the best possible grounding of the filter.
- 4) Use the shield cable for the control , motor and other main wiring which are connected to the drive. These shields should be securely grounded.
- 5) It is important that all wire lengths be kept as short as possible and that incoming mains and outgoing motor cables be kept well separated.

"To minimize the conducted radio disturbance in the power distribution systems, the length of the motor-cable should be as short as possible."

- 6) In the case where a ferrite ring is provided with the filter, fit the ferrite ring so the conductors pass through the center of the ferrite. Wire the cable according to Fig. 6 or Fig. 7, paying attention to the applied drive type.

[Hp] Max. rated voltage 3 Phase 230 VAC

	Filter Type	Rated Current	Tested Motor Cable Length		RFI Filter Data					Note
			EN55011 Class B	EN55011 Class A	Dimensions L x W x H (mm)	Mount. Dim. Y x X (mm)	Ferrite Ring (Qty)	Total Wt. (lb)	Watt loss [W]	
0.25 0.5 1	EFL075SP2 (EFL-0.75SP-2)	6A	—	164 ft (50m)	9.57 x3.35x3.66 (243x85x93)	8.98x2.32 (228x59)	OF1 [1]	3.3	0.4 1.4 5.1	Fig. 1 Separate Type
2 3 5	EFL370SP2 (EFL-3.7SP-2)	25A			9.17x4.13x5.35 (233x105x136)	8.46x 3.15 (215x80)	OF2 [1]	5.5	3.9 8.2 21	
7.5 10	EFL750SP2 (EFL-7.5SP-2)	50A			10.75x4.72x6.22 (273x120x158)	10x3.74 (254x95)	OF2 [1]	11.0	24 40	
15 20	EFL150SP2 (EFL-15SP-2)	100A			20.2x8.07x7.6 (513x205x193)	19.17x6.30 (487x160)	OF3 [1]	44.1	42 68	
25 30	EFL220SP2 (EFL-22SP-2)	150A							74 99	
40	RF3180F11 (RF3180-F11)	180A							19.49x7.87x6.3 (495x200x160)	
50 60	RF3280F11 (RF3280-F11)	280A	—	328 Ft (100m)	23.11x9.84x8.07 (587x250x205)	22.05x3.35 (560x85)	—	48.7	120	Fig. 4 Separate Type
75 100 125	RF3400F11 (RF3400-F11)	400A					—	110	220	

[HP] Max. rated voltage 3 Phase 480 VAC

0.5 1	EFL075G114 (EFL-0.75G11-4)	5A	33 ft (10m)	164 ft (50m)	12.6x4.56x1.65 (320x116x42)	11.54x3.54 (293x90)	—	2.0	0.8 3.1	Fig. 2 Separate/ Integral Type
2 3 5	EFL400G114 (EFL-4.0G11-4)	12A			12.6x6.1x1.77 (320x155x45)	11.54x4.13 (293x105)	—	2.6	3.1 6.9 18	
7.5 10	EFL750G114 (EFL-7.5G11-4)	35A			13.43x8.86x1.87 (341x225x47.5)	12.24x6.57 (311x167)	—	4.0	10 17 24	
15 20	EFL150G114 (EFL-15G11-4)	50A			19.69x9.84x2.76 (500x250x70)	17.68x7.28 (449x185)	—	7.9	29 49	
25 30	EFL220G114 (EFL-22G11-4)	72A					—	8.8	47 62	
40	RF3100F11 (RF3100-F11)	100A					17.13x7.87x5.19 (435x200x130)	16.06x6.54 (408x166)	—	
50 60 75 100 125	RF3180F11 (RF3180-F11)	180A	19.49x7.87x6.3 (495x200x160)	18.4x6.53 (468x166)	—	48.7	60			
150 200	RF3280F11 (RF3280-F11)	280A	—	328 ft (100m)	23.11x9.84x8.07 (587x250x205)	22.05x3.35 (560x85)	—	84.8	120	Fig. 4 Separate Type
250 300 350	RF3400F11 (RF3400-F11)	400A					—	110	220	
400 450 500 600	RF3880F11 (RF3880-F11)	800A					—	130	180	
			27.09x14.33x7.09 (688x364x180)	25.51x5.91 (648x150)	F200 160 [3]	142	180			

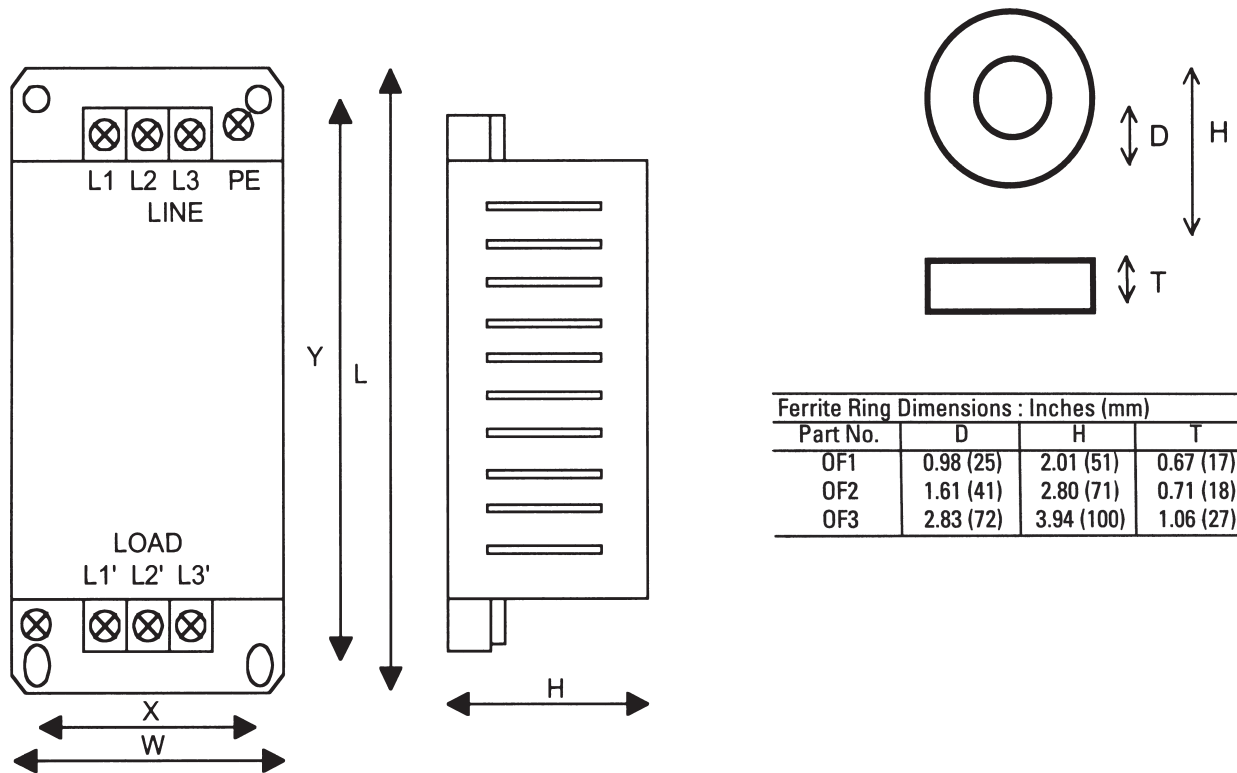

Figure 1

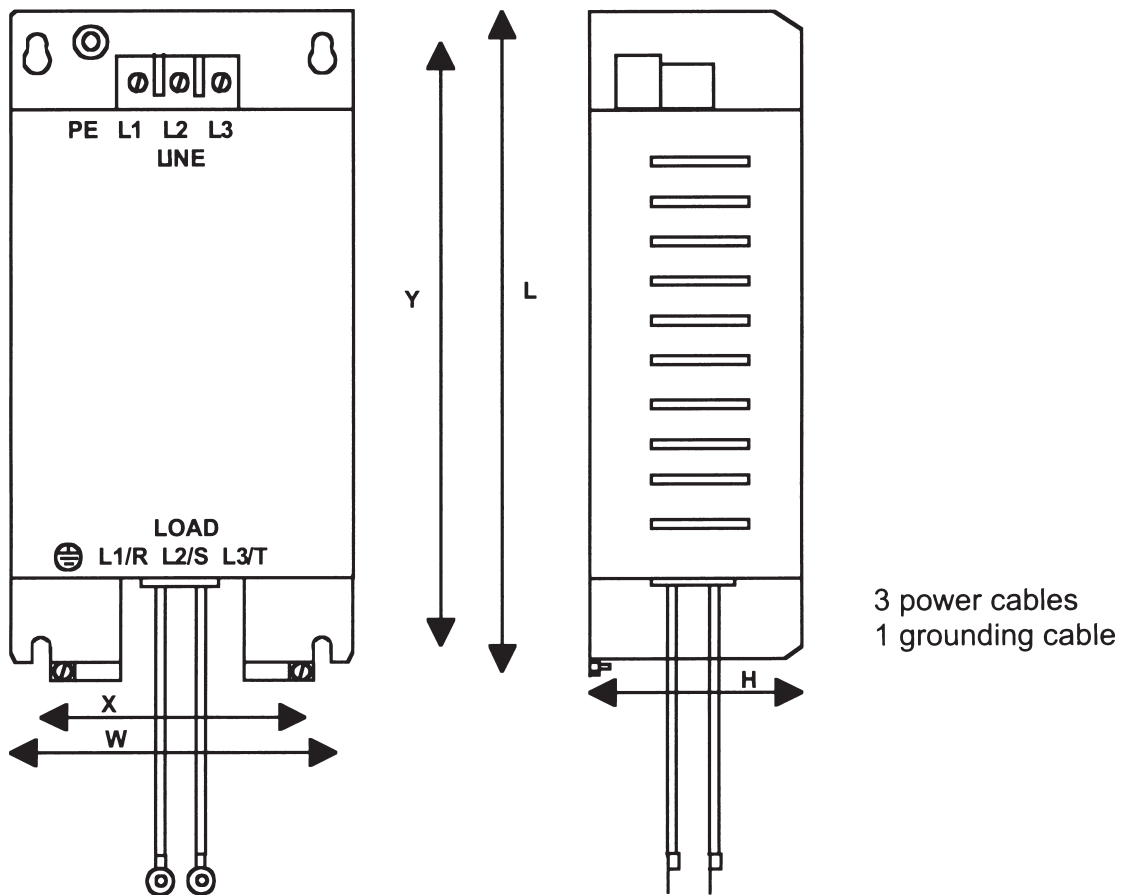
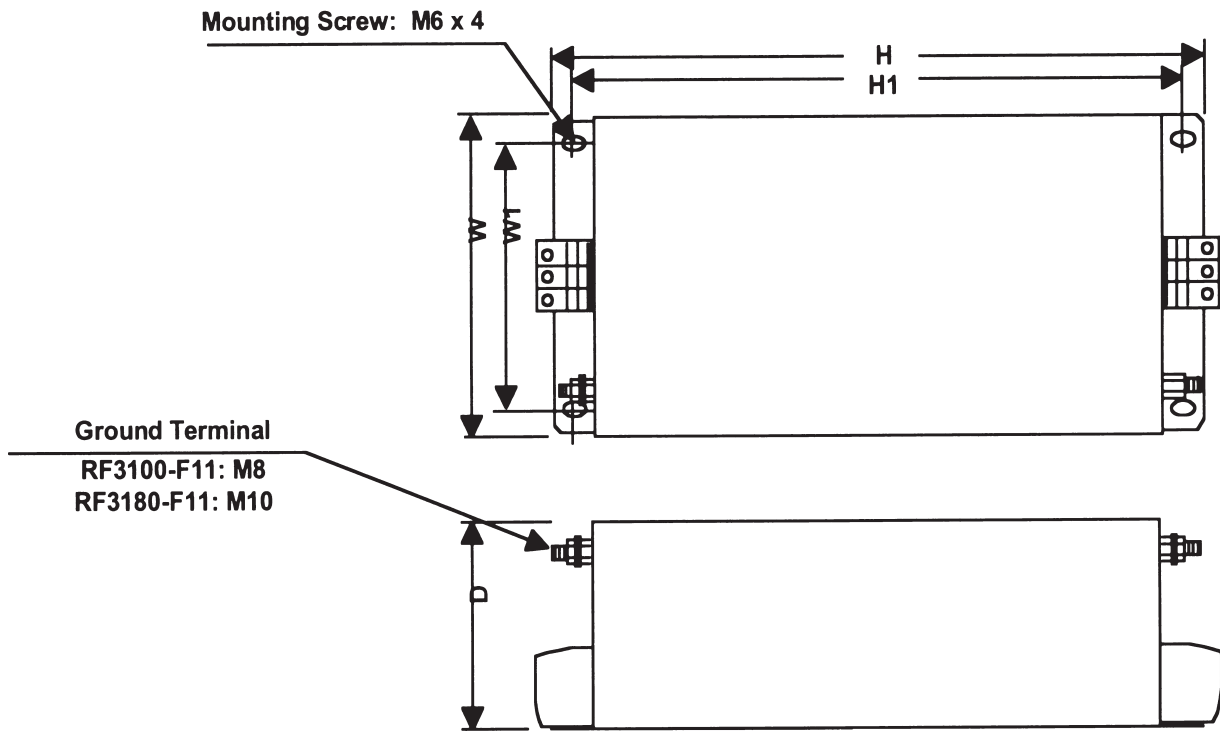

Figure 2



Filter Type	Dimensions : Inches (mm)				
	W	W1	H	H1	D
RF3100-F11	7.87 (200)	6.54 (166)	17.1 (435)	16.1 (408)	5.12 (130)
RF3180-F11	7.87 (200)	6.54 (166)	19.5 (495)	18.4 (468)	6.30 (160)

Figure 3 Outline Dimensions (RF3100-F11, RF3180-F11)

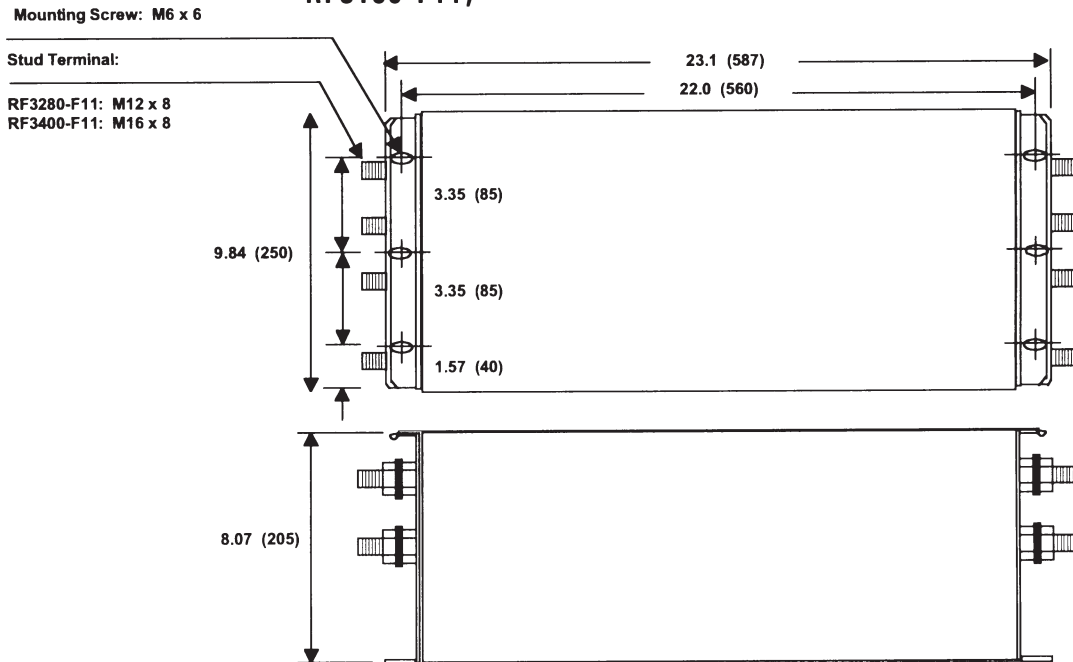

Figure 4 Outline Dimensions (RF3280-F11, RF3400-F11)

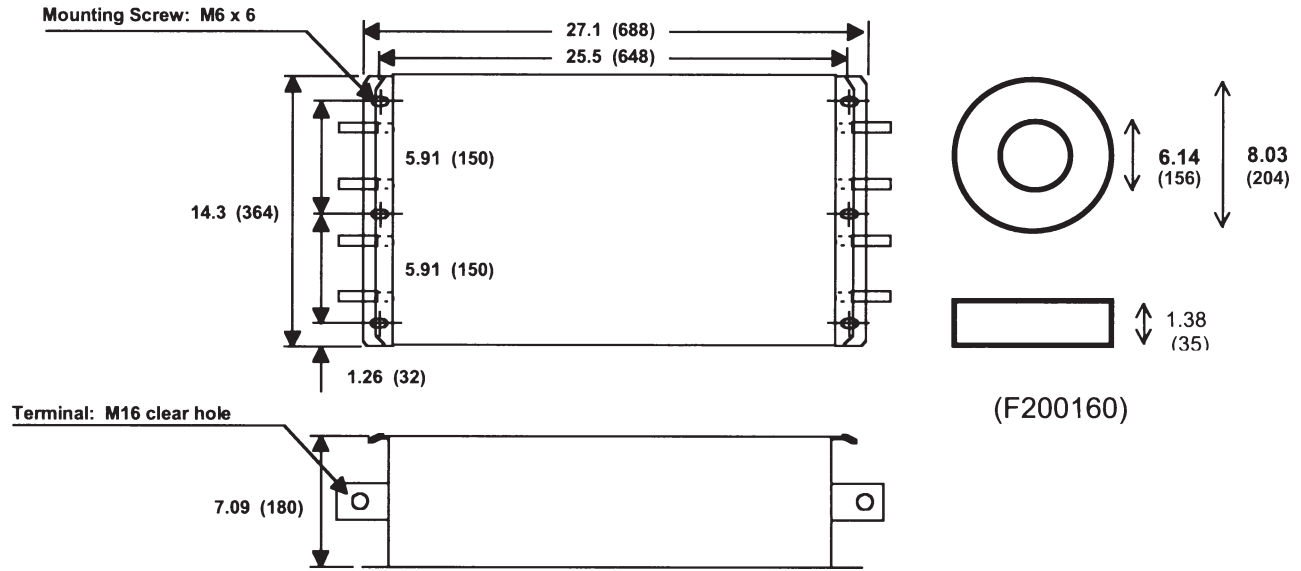

Figure 5 Outline Dimensions (RF3880-F11)

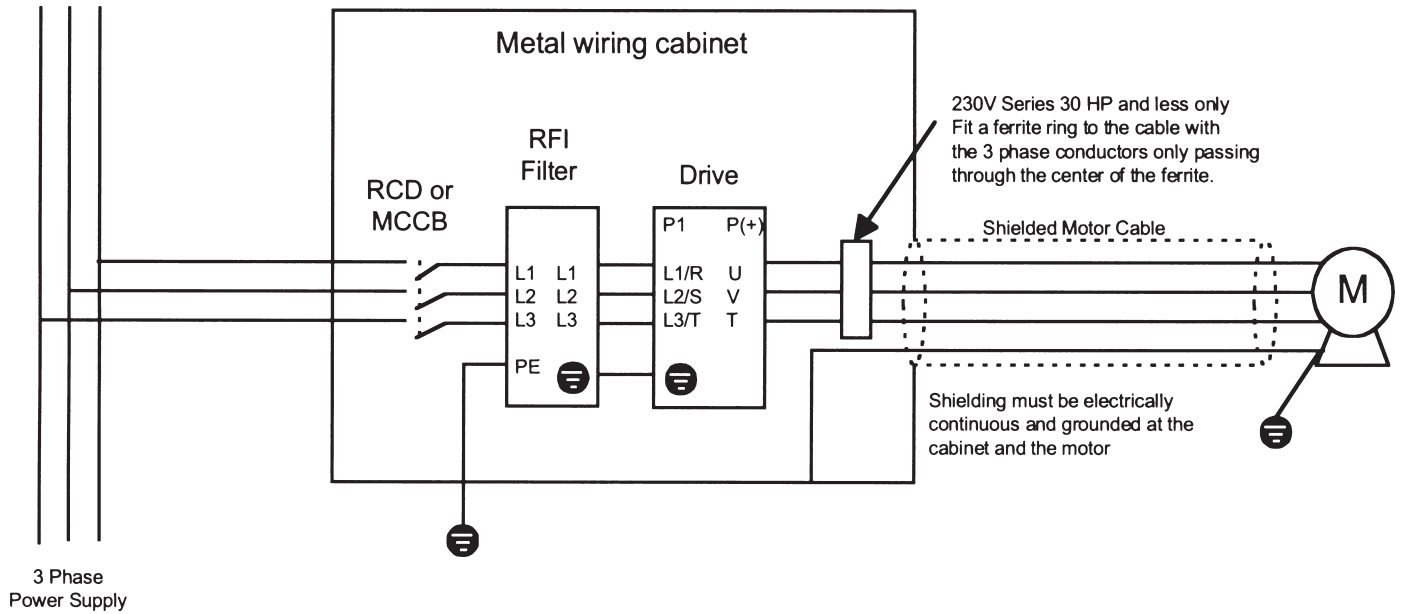

Figure 6 230V all HP
460V less than 350HP

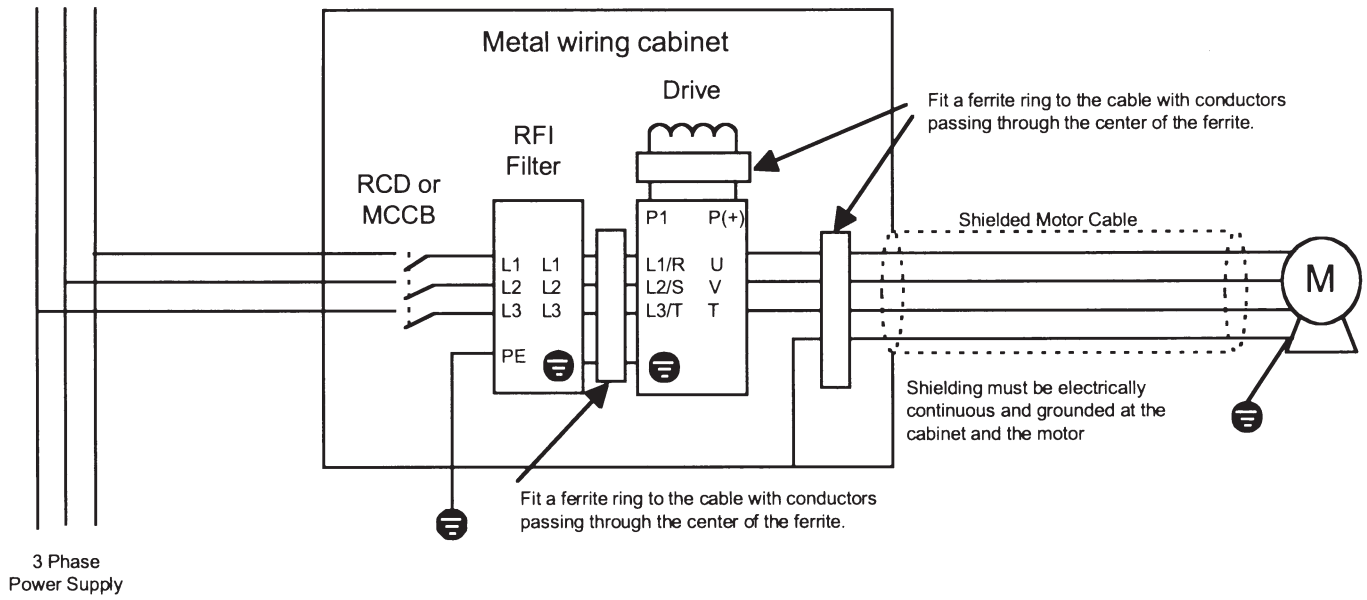

Figure 7 460V 400HP and higher