



Boston Gear
14 Hayward Street
Quincy, MA 02171

tel 617.328.3300
fax 617.479.6238

ACE20UG
08/03

*** ACE 20 SERIES ***
ADJUSTABLE FREQUENCY
AC MOTOR CONTROLLERS
USER'S GUIDE
(1/8 - 10 HP)

The Technical Manual (ACE20TM) is available at our
web site (BostonGear.com) or by calling 888-999-9860.

MODEL NO. _____

SERIAL NO. _____

INPUT SUPPLY _____ VAC, 50/60 Hz

HORSEPOWER _____

These instructions do not purport to cover all details or variations in equipment, nor to provide every possible contingency to be met during installation, operation, and maintenance. If further information is desired, or if particular problems arise that are not covered sufficiently for the purchaser's purpose, the matter should be referred to Boston Gear, Quincy, MA 02190, 617-328-3300 .

This document contains proprietary information of Boston Gear and is furnished to its customer solely to assist that customer in the installation, testing, operation, and/or maintenance of the equipment described. This document shall not be reproduced in whole or in part, nor shall its contents be disclosed to any third party without the written approval of Boston Gear.

Genius is a registered trademark of GE Fanuc Automation North America, Inc.
Profibus is a trademark of Profibus International.

WARNING:

This equipment has the potential to cause electric shock or burns. Only personnel who are adequately trained and thoroughly familiar with the equipment and the instructions should install, operate, or maintain this equipment.

Isolation of test equipment from the equipment under test presents potential electrical hazards. If the test equipment cannot be grounded to the equipment under test, the test equipment's case must be shielded to prevent contact by personnel.

To minimize hazard of electrical shock or burns, approved grounding practices and procedures must be strictly followed.

WARNING:

To prevent personal injury or equipment damage caused by equipment malfunction, only adequately trained personnel should modify any programmable machine.

Table of Contents

i. Preface		7. Troubleshooting	7-1
Cautions	ii	Protective Function Activation	7-1
General Precautions	iv	Abnormal Motor Rotation	7-5
Compliance with UL/cUL Standards	v	8. Warranty, Parts and Service	8-1
Model Numbering System Diagram	vii	Warranty Coverage	8-1
Weights & Dimensions	viii	Out of Warranty Procedures	8-1
1. Before Using ACE 20 Series Drives	1-1	Motors	8-1
Receiving Inspection	1-1	In-Warranty Failure Checklist	8-2
External View	1-1	9. Specifications	9-1
Handling	1-3	Standard Specifications	9-1
NEMA 1 Kit	1-5	Common Specifications	9-3
Rating Efficiency and Watts Loss	1-9	External Dimensions	9-7
2. Installation and Connection	2-1		
Operating Environment	2-1		
Installation Method	2-1		
Connection	2-2		
Basic Connection	2-2		
Connection of Main Circuit and Grounding Terminal	2-4		
Connection of Control Terminal	2-6		
Terminal Layout	2-9		
3. Operation	3-1		
Inspection and Preparation Before Operation	3-1		
Operation Method	3-1		
Test Operation	3-1		
4. Keypad Panel	4-1		
Appearance of Keypad Panel	4-1		
Alarm Occurrence	4-3		
Digital Frequency Setting Method	4-3		
Operation Methods	4-3		
Recalibration for ACE202V3P0001N1 Drives	4-7		
5. Selecting Functions	5-1		
Function Selection List	5-1		
6. Protective Operation	6-1		
List of Protective Operations	6-1		
Alarm Reset	6-2		

CAUTION

- ACE 20 Series Drives are designed to drive a three-phase induction motor. Read through this instruction manual and be familiar with the correct method of handling.
- Improper handling may cause mis-operation and shorten the life of ACE 20 Series Drives.
- This manual should be delivered to the user of the drive. This manual should be kept in a safe place until the ACE 20 Series Drive is de-commissioned.
- Refer to additional manuals for optional equipment.

Introduction

Safety precautions

Read through this manual before starting installation, connection (wiring), operation, maintenance or inspection. Be familiar with the drive, information about safety, and all the precautions before starting operation.

The safety precautions are classified into the following categories in this manual.

DANGER

Negligence in following precautions of this type can cause death or serious injuries.

CAUTION

Negligence in following precautions of this type can cause dangers including intermediate injuries or material losses.

Negligence in following precautions of this type under the CAUTION title can cause serious results in certain circumstances. These safety precautions are important and must be observed at all times.

Purposes

DANGER

- ACE 20 Series Drives are designed to drive a three-phase induction motor. They should not be used for single-phase motors or other purposes. **Otherwise, fire could occur.**
- ACE 20 Series Drives may not be used for a life-support system or other purposes directly related to human safety.
- Though ACE 20 Series Drives are manufactured under strict quality control, safety devices should be installed for applications where serious accidents or material losses are possible.

Installation

DANGER

- Install the drive on a nonflammable material such as metal. **Otherwise, fire could occur.**
- Do not place flammable material nearby. **Otherwise, fire could occur.**

CAUTION

- Do not carry the drive by the cover. **Otherwise, the drive may drop and cause injuries.**
- Do not allow lint, paper, wood chips, dust, metallic chips or other foreign matter into the ACE 20 Series Drive. **Otherwise, fire or an accident could occur.**
- Do not install or operate the drive if it is damaged or missing parts. **Otherwise, fire, an accident or injuries could occur.**

Wiring

DANGER

- When connecting the drive to the AC power supply, add a circuit breaker with ground fault protection. **Otherwise, fire could occur.**
- Be sure to connect the grounding cable. **Otherwise, electric shock or fire could occur.**
- Only qualified electricians should perform the wiring. **Otherwise, electric shock could occur.**
- Initiate wiring only after checking that the AC power supply is turned off. **Otherwise, electric shock could occur.**
- Begin wiring after mounting the main body of the drive. **Otherwise, electric shock or injuries could occur.**
- Both grounding terminals of 7-1/2 - 10 HP drives have to be tightened securely, even if one grounding terminal is used. **Otherwise, electric shock or fire could occur.**

CAUTION

- Check that the number of phases and the rated voltage of the drive agree with the phases and voltage of the AC power supply. **Otherwise, fire or an accident could occur.**
- Do not connect the AC power cables to the output terminals (U, V, W). **Otherwise, fire or an accident could occur.**
- Do not connect a braking resistor directly to the DC terminals (P (+), N (-)). **Otherwise, fire or an accident could occur.**
- The drive, motor and wiring generate electrical noise. Take care installing nearby sensors and devices. **Otherwise, an accident could occur.**

Operation

DANGER

- Be sure to install the ACE 20 Series cover before turning the power on. Do not remove the cover while power is applied. **Otherwise, electric shock could occur.**
- Do not operate switches with wet hands. **Otherwise, electric shock could occur.**
- If the retry function has been selected, the drive may automatically restart after tripping.
(Design the machine so that human safety is ensured after restarting. **Otherwise, an accident could occur.**)
- If the torque limit function has been selected, the drive may operate at an acceleration/deceleration rate or speed different from the set ones. Design the machine so that safety is ensured. **Otherwise, an accident could occur.**
- The STOP key is only effective when a function code setting has been established to enable the STOP key. Prepare an emergency stop switch separately. **Otherwise, an accident could occur.**
- If an alarm reset is made with the reference signal present, a sudden start will occur. Check that the reference signal is turned off in advance. **Otherwise, an accident could occur.**
- Do not touch the drive terminals while power is applied to the drive, even if the the motor is stopped. **Otherwise, electric shock could occur.**

CAUTION

- Do not turn the main circuit power on or off to start or stop the motor. **Otherwise, failure could occur.**
- Do not touch the heat sink or braking resistor since they may become very hot. **Otherwise, burns could occur.**
- Check the performance of the motor and machine before running them at high speed. **Otherwise, injuries could occur.**
- The brake function of ACE 20 Series Drives do not provide mechanical holding. **Therefore, injuries could occur if precautions are not taken.**

DANGER

- Turn the AC power off and wait at least five minutes before starting inspection.

(Check that the charge lamp is not lit, and check that the DC voltage across the P (+) and N (-) terminals is lower than 25 Vdc. **Otherwise, electric shock could occur.**)

- Maintenance, inspection and parts replacement should be made only by qualified persons.

(Take off watches, rings and other metallic items before starting work.)

(Use insulated tools.)

Otherwise, electric shock or injuries could occur.

Disposal

CAUTION

- Handle the ACE 20 Series Drive as industrial waste when disposing of it. **Otherwise, injuries could occur.**

Others

DANGER

- Never re-work the drive. **Otherwise, electric shock or injuries could occur.**

General Precautions

Drawings in this manual may be illustrated without covers or safety shields for clearer explanation. Restore the covers and shields to the original state and observe the description in the manual before starting operation.

Compliance with low voltage directive in EU [Applicable to products with CE or TÜV mark]

- Safe separation for control interface of this drive is provided when this drive is installed in overvoltage category II. PELV(Protective Extra Low Voltage) circuit or SELV(Safety Extra Low Voltage) circuit should be connected to the interface directly.
 - Basic insulation for control interface of this drive is provided when this drive is installed in overvoltage category III. An insulation transformer has to be installed between power supply mains and this drive when SELV circuit is connected to this drive directly. Otherwise, supplementary insulation between control interface of this drive and environment must be provided.
 - The ground terminal G should always be connected to the ground. Don't use RCD as the sole method of electric shock protection. Sizes of the external PE (ground) conductor should be the same size as the input phase conductor and capable of the same fault currents.
 - Use MCCB or MC that conforms to EN or IEC standard.
 - Where RCD (Residual-current-operated protective device) is used for protection of direct or indirect contact, only **RCD of type B** is allowed on the supply side of this EE (Electric equipment). Otherwise, other protective measures shall be applied such as separation of the EE from the environment by double or reinforced insulation or isolation of EE and supply system by a transformer.
 - The drive is supplied as standard with a NEMA 1 enclosure.
-
- Use prescribed wire according to the EN60204 Appendix C.
 - Install the drive, AC or DC reactor, output filter in an enclosure that meets the following requirements.
 - 1) When a person can easily touch connecting terminals or live parts, install the devices in an enclosure with minimum of IP4X degree of protection.
 - 2) When a person cannot easily touch connecting terminals or live parts, install the devices in an enclosure with a minimum of IP2X degree of protection.
-
- If it is necessary to install the drive with an appropriate RFI filter to conform to the EMC directive, it is the customer's responsibility to check whether the equipment is installed in accordance with EMC directives.
 - Do not connect copper wire to ground terminals directly. Use crimp terminals with tin or equivalent plating to reduce electrochemical action.
 - Do not remove the keypad panel before disconnecting power and do not insert/remove the extension cable for remote keypad panel while power is on. Confirm that the extension cable is securely latched to the keypad panel and the drive.
 - Basic insulation for control interface of this drive is provided at altitudes up to 3000 meters. Use at altitudes over 3000 meters is not permitted.
 - The neutral of the power supply has to be grounded for 460V input.

Compliance with UL/cUL standards [Applicable to products with UL/cUL mark]

CAUTION

1. [WARNING] Be sure to turn the AC power off to the ACE 20 Series Drive before starting work.
2. [CAUTION] When the charge lamp is lit, the ACE 20 Series Drive is still charged at a dangerous voltage.
3. [WARNING] There are live parts inside the ACE 20 Series Drive.
4. The ACE 20 Series Drive is approved as a part to be used inside a panel.
5. Wire to the input, output and control terminals of the ACE 20 Series Drive, referring to the table below. Use UL certified round crimp terminals on the input and output terminals with the insulation cover removed to obtain the correct insulation distance. Use a crimping tool recommended by the terminal manufacturer.
6. Install a fuse or circuit breaker between the AC power supply and the ACE 20 Series Drive, using the table below.

THREE-PHASE SUPPLY	DRIVE CATALOG NO.	FUSE ^a (Amps)	CIRCUIT BREAKER (Amps)	POWER TERMINALS L1/R, L2/S, L3/T		CONTROL TERMINALS	
				P1, P(+) DB, N(-) U, V, W		WIRE SIZE AWG ^b	TIGHTENING TORQUE Inch-Lbs (NM)
230 VAC	ACE202V3P0001N1	3	5	14	10.6 (1.2)	20	3.5 (0.4)
	ACE202V3P0002N1	6					
	ACE202V3P0005N1	10					
	ACE202V3P0010N1	15					
	ACE202V3P0020N1	20	20	12	15.9 (1.8)		
	ACE202V3P0030N1	30	30				
	ACE202V3P0050N1	40	40	10	31.0 (3.5)		
	ACE202V3P0075N1	50	50	8			
ACE202V3P0100N1	60	60	6				
460 VAC	ACE204V3P0005N1	6	5	14	15.9 (1.8)	20	3.5 (0.4)
	ACE204V3P0010N1						
	ACE204V3P0020N1	10	10				
	ACE204V3P0030N1	15	15				
	ACE204V3P0050N1	20	20	12	31.0 (3.5)		
	ACE204V3P0075N1	30	30				
	ACE204V3P0100N1	40	40	10			

a. Use UL approved AC600V “Class J fuse.”

b. Use copper wire with allowable maximum temperature of 60 to 75 degrees C.

CAUTION

7. ACE 20 Series, 230V drives, are suitable for use on a circuit capable of delivering not more than 20,000 rms symmetrical amperes, 240V maximum.
8. ACE 20 Series, 460V drives, are suitable for use on a circuit capable of delivering not more than the following symmetrical amperes, 480V maximum: When a fuse is installed, 20,000A; when the circuit breaker is installed, 5000A.
9. ACE 20 Series Drives are supplied as standard with a NEMA 1 enclosure.
10. A class 2 circuit wired with class 1 wire.

ACE 20 Series Model Numbering System

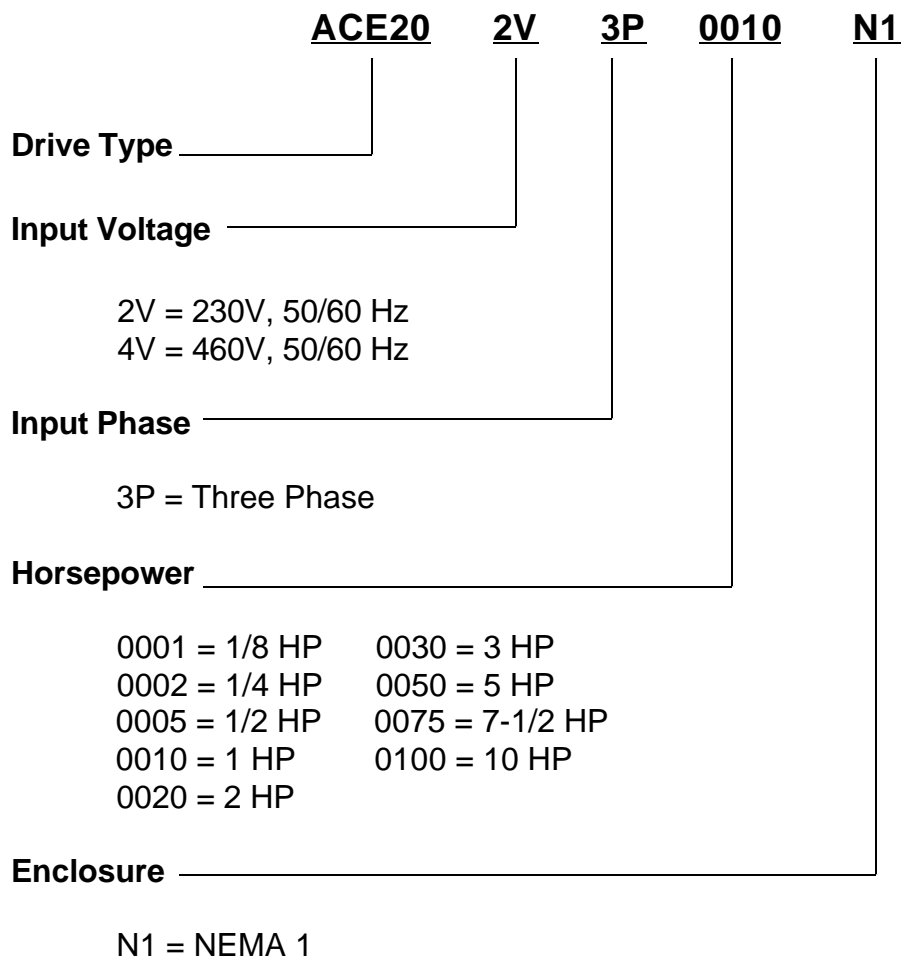

ACE 20 Series Weights & Dimensions

HP Rating	Enclosure	Output Current (A)	Overload (A) (150% 1min.)	Catalog No.	Item Code	Dimensions H* x W x D (inches)	Weight (lbs)
230VAC, 3 phase, 50/60Hz Input							
1/8	NEMA 1	0.7	1.1	ACE202V3P0001N1	43350	6.06 x 2.76 x 3.98	2.4
1/4	NEMA 1	1.4	2.1	ACE202V3P0002N1	43351	6.06 x 2.76 x 3.98	2.4
1/2	NEMA 1	2.5	3.8	ACE202V3P0005N1	43352	6.06 x 2.76 x 4.65	2.8
1	NEMA 1	4.0	6.0	ACE202V3P0010N1	43353	6.06 x 2.76 x 5.67	3.1
2	NEMA 1	7.0	10.5	ACE202V3P0020N1	43354	6.06 x 4.17 x 5.91	5.1
3	NEMA 1	10.0	15.0	ACE202V3P0030N1	43355	6.06 x 4.17 x 5.91	5.1
5	NEMA 1	16.5	24.8	ACE202V3P0050N1	43356	6.06 x 6.69 x 6.22	7.9
7.5	NEMA 1	23.5	35.3	ACE202V3P0075N1	43357	8.66 x 7.00 x 6.22	17.7
10	NEMA 1	31.0	46.5	ACE202V3P0100N1	43358	8.66 x 7.00 x 6.22	17.7

*With NEMA 1 Kit.

460VAC, 3 phase, 50/60Hz Input

1/2	NEMA 1	1.4	2.1	ACE204V3P0005N1	43359	6.06 x 4.17 x 4.96	4.3
1	NEMA 1	2.1	3.2	ACE204V3P0010N1	43360	6.06 x 4.17 x 5.91	4.7
2	NEMA 1	3.7	5.6	ACE204V3P0020N1	43361	6.06 x 4.17 x 6.69	5.1
3	NEMA 1	5.3	8.0	ACE204V3P0030N1	43362	6.06 x 4.17 x 6.69	5.5
5	NEMA 1	8.7	13.1	ACE204V3P0050N1	43363	6.06 x 6.69 x 6.22	7.5
7.5	NEMA 1	12	18.0	ACE204V3P0075N1	43364	8.66 x 7.00 x 6.22	17.7
10	NEMA 1	16	24.0	ACE204V3P0100N1	43365	8.66 x 7.00 x 6.22	17.7

1. Before Using ACE 20 Series Drives

1.1 Receiving Inspection

If there are any problems with the drive, contact the distributor or Boston Gear.

Unpack and check the following items.

- (1) Check the ratings nameplate to confirm that the drive is the one that was ordered.

SOURCE: Number of input phases, input voltage, input frequency, input current

OUTPUT: Number of output phases, rated output capacity, rated output voltage, output frequency range, rated output current, overload current rating

1.2 External View

- (1-1) Overall view



- (2) Check for breakage, missing parts, and dents or other damage on the cover and the main body that may have occurred during transportation.
- (3) Instruction manual for the drive is included.

(1-2) Overall view (5-1/2, 7-1/2 HP)

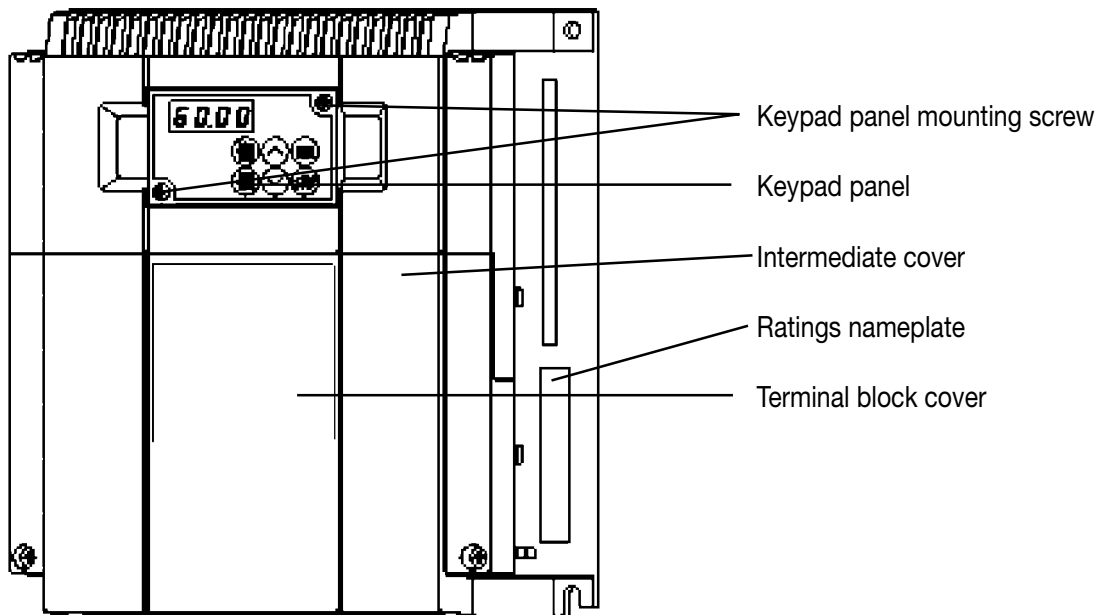

(2-1) View of wiring area (5 HP or below)

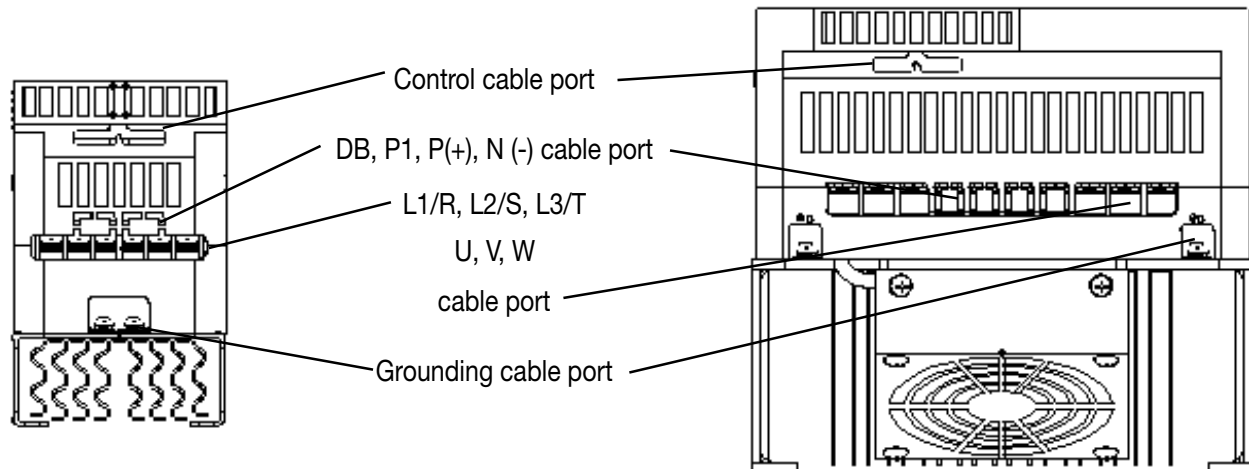

A barrier is provided in the cable cover for the P1, P(+), DB and N(-) cable port. Cut the barrier using nippers or the equivalent before wiring.

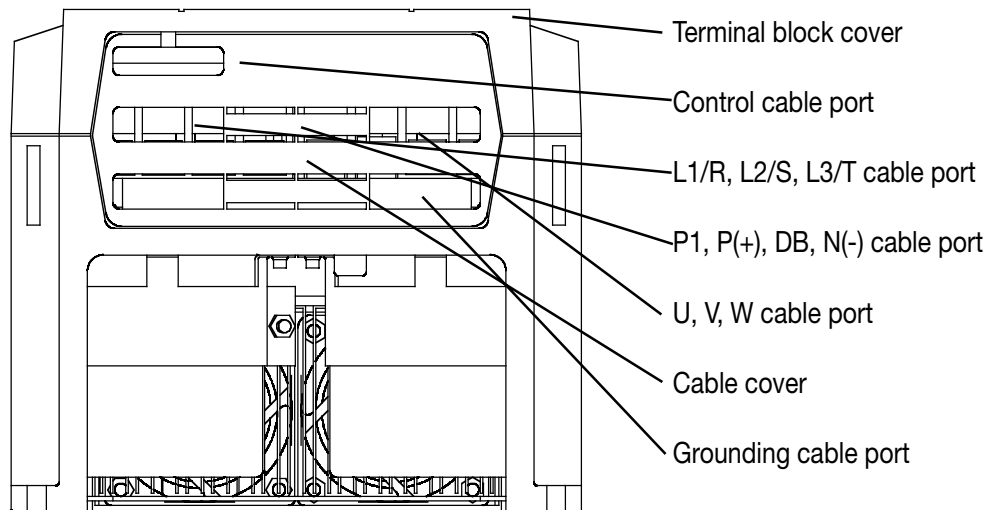
(2-2) View of wiring area (7-1/2, 10 HP)

A barrier is provided in the cable cover for the P1, P(+), DB and N(-) cable port. Cut the barrier using nippers or the equivalent before wiring.

1.3 Handling**(1) Removing the control terminal block cover (5 HP or below)**

While lightly pushing in the sides of the control terminal block cover at the catches, lift the cover as shown in Fig. 1-3-1.

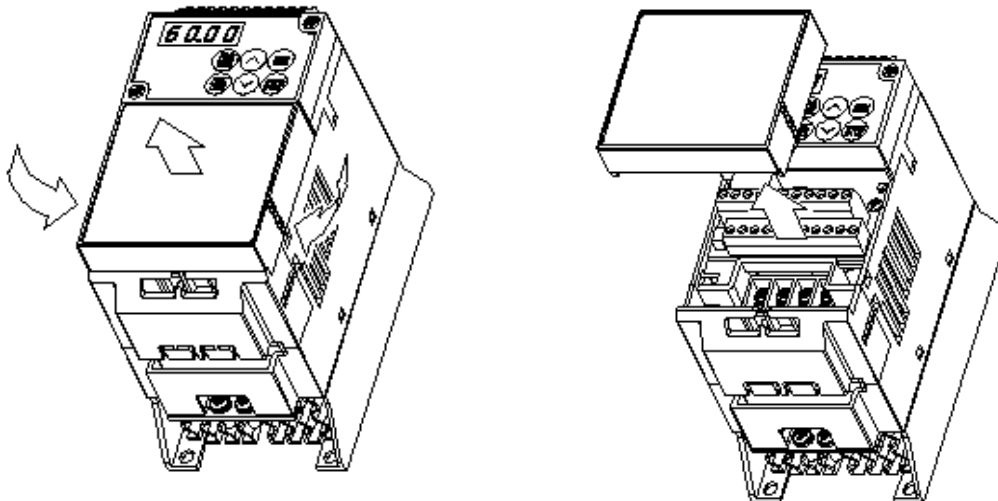

Fig. 1-3-1 Removing the control terminal block cover

(2) Removing the main circuit terminal block cover (5 HP or below)

While lightly pushing in the sides of the main circuit terminal block cover at the catches, slide it toward you as shown in Fig. 1-3-2.

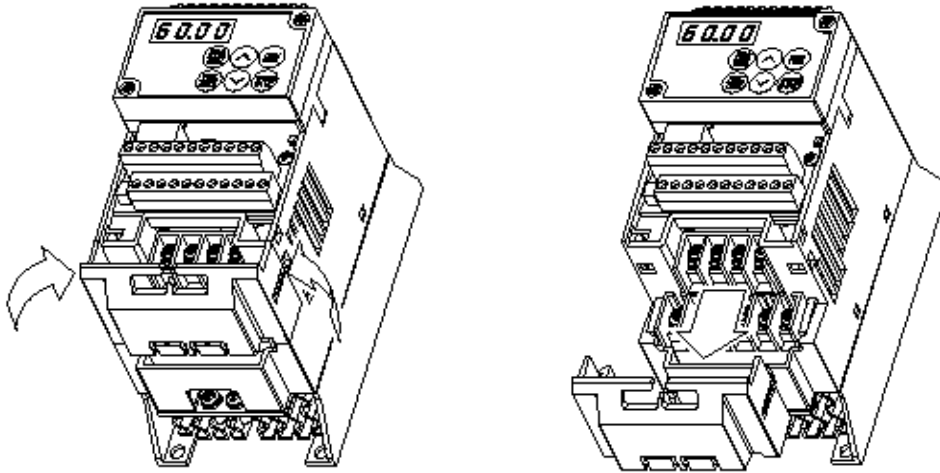

Fig. 1-3-2 Removing the main circuit terminal block cover

(3) Removing the terminal block cover (7-1/2, 10 HP)

Loosen the screws holding the terminal block cover. While lightly pushing the sides of the terminal block cover at the catches, lift the cover as shown in Fig. 1-3-3.

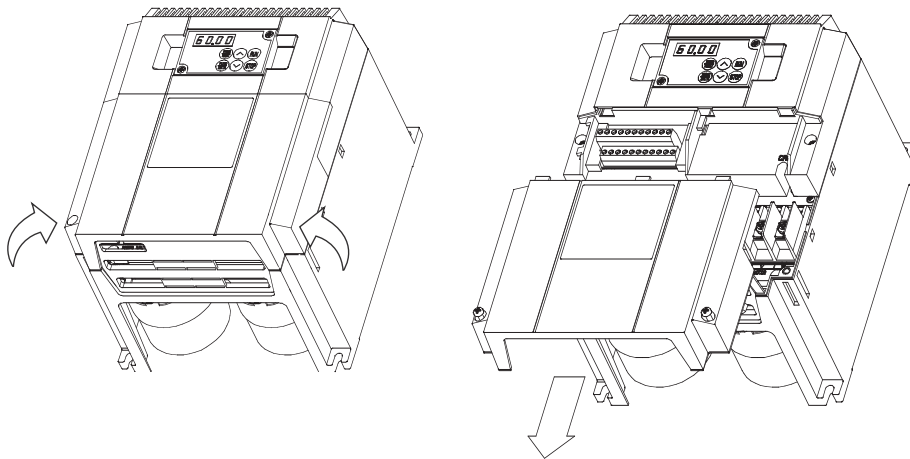

Fig. 1-3-3 Removing the terminal block cover

(4) Removing the keypad panel

Loosen the keypad panel mounting screws and remove the keypad panel as shown in Fig. 1-3-4.

During the procedure, slowly remove the keypad panel from the unit. If the keypad panel is handled abruptly, the connector will be damaged.

Mounting screw (M3)

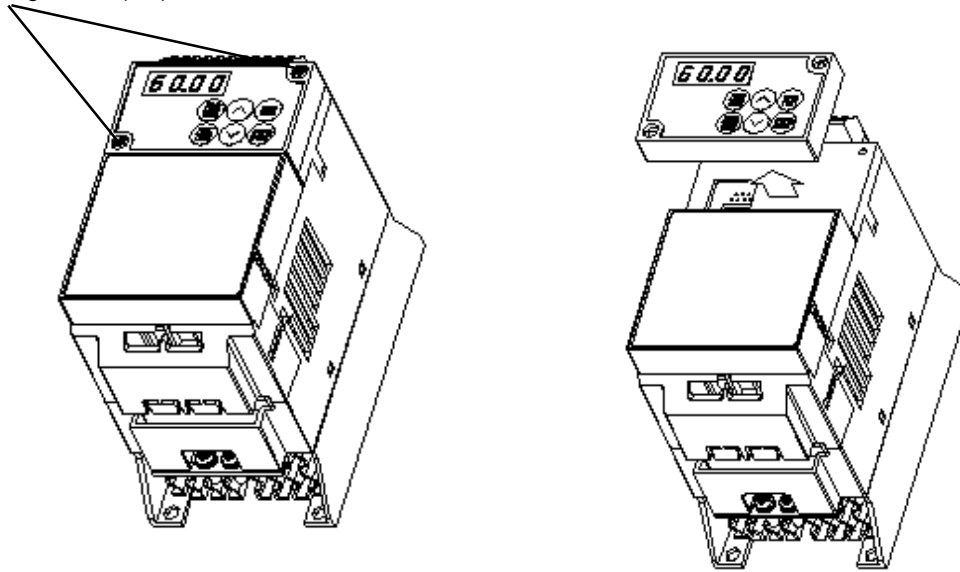
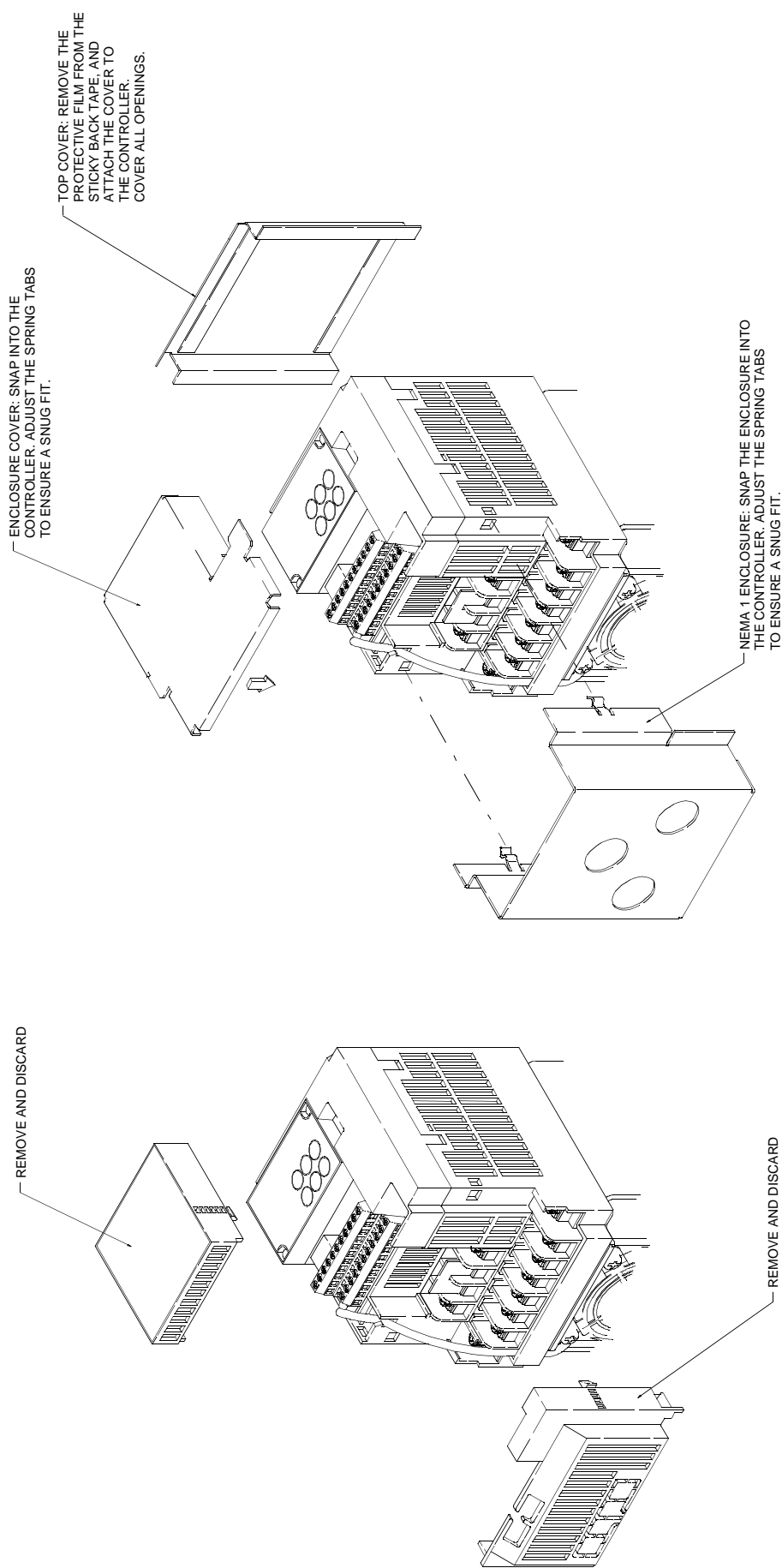

Fig. 1-3-4 Removing the keypad panel

Reverse the procedures to mount the terminal block cover and keypad panel.

1.4 NEMA 1 Kit

A NEMA 1 kit accompanies every ACE 20 Series drive. This kit converts the basic drive to a NEMA 1 configuration. If a NEMA 1 drive is desired, perform the instructions on page 1-6, 1-7 or 1-8, as applicable.



STEP 1

STEP 2

NOTE: SHAPE OF NEMA 1 PARTS MAY BE SLIGHTLY DIFFERENT THAN SHOWN.

ACE 20 SERIES, 1/8 - 3HP

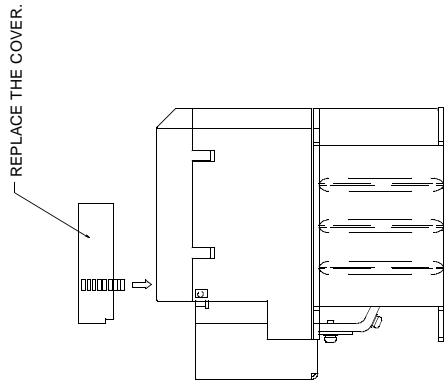

STEP 3

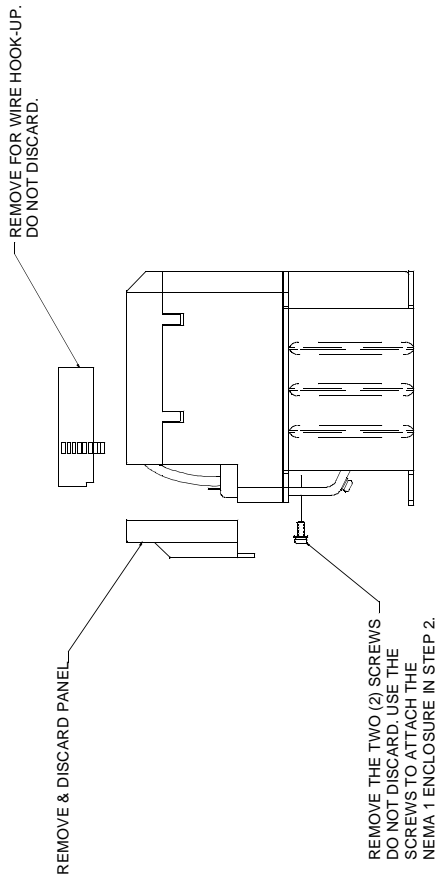

STEP 1

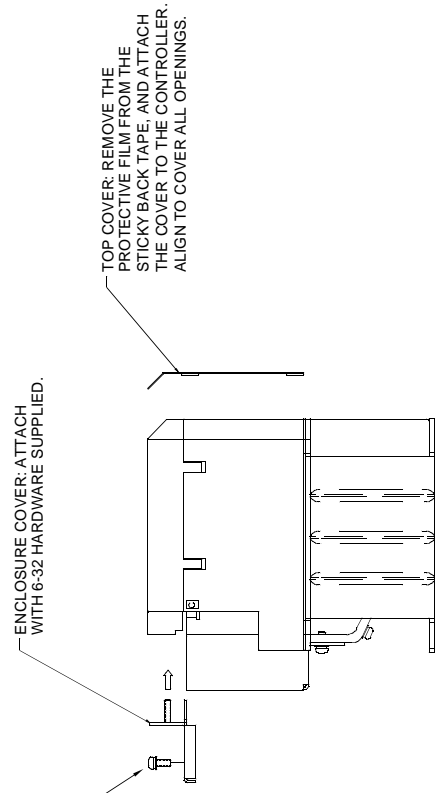

STEP 4

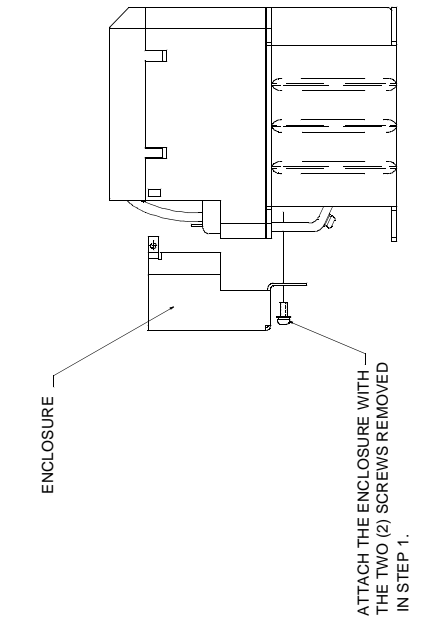

STEP 2

ACE 20 SERIES, 5HP

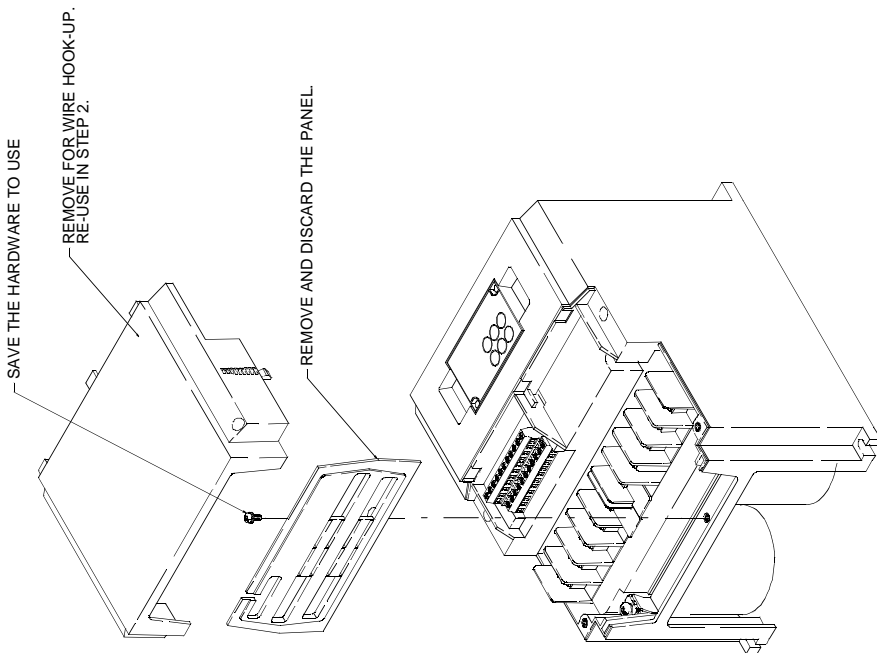

STEP 1 DISASSEMBLY

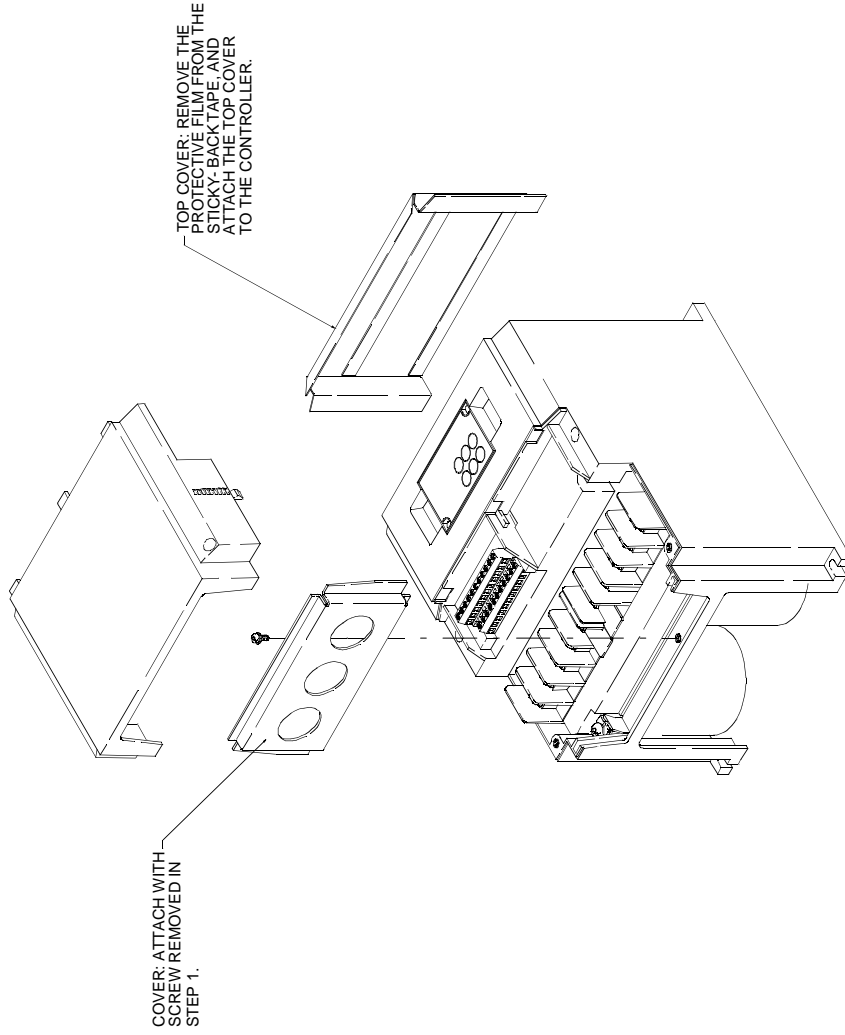

STEP 2 NEMA 1 ASSEMBLY

ACE 20 SERIES, 7-1/2 & 10HP

1.5 Drive Ratings Efficiency and Watts Loss

HP Rating	Rated Output Current (Amps)	Rated Output (KVA)	Rated Output (KW)	Efficiency at 0.75KHz (%)	Efficiency at 15KHz (%)	Watts Loss at 0.75KHz (W)	Watts Loss at 15KHz (W)
230VAC Three phase input							
1/8	0.7	0.28	0.1	88.6	87.1	20	23
1/4	1.4	0.56	0.2	91.5	89.9	27	32
1/2	2.5	1.0	0.4	92.9	90.9	38	50
1	4	1.6	0.75	94.2	92.4	57	77
2	7	2.8	1.5	95.4	94.1	85	110
3	10	4.0	2.2	95.6	94.0	120	165
5	16.5	6.6	3.7	95.8	94.4	190	260
7.5	23.5	9.4	5.5	96.6	95.2	217	310
10	31	12.3	7.5	96.7	95.3	287	415

460VAC Three phase input							
0.5	1.4	1.1	0.4	95.1	91.8	26	45
1	2.1	1.7	0.75	96.3	93.6	36	64
2	3.7	2.9	1.5	97.0	94.5	55	103
3	5.3	4.2	2.2	97.1	94.6	78	149
5	8.7	6.9	3.7	97.4	94.9	116	235
7.5	12	9.6	5.5	97.8	95.5	137	289
10	16	12.7	7.5	97.8	95.5	189	389

Notes:

2. Installation and Connection

2.1 Operating Environment

Install the drive in an environment as described in Table 2-1-1.

Table 2-1-1 Operating environment

Item	Specifications
Site	Indoors
Ambient Temperature	-10 to +40°C (+14 to 104°F)
Relative Humidity	5 to 95% (without condensation)
Atmosphere	The drive must not be exposed to dust, direct sunlight, corrosive gases, oil mist, vapor or water drops. There must be little salt. No condensation shall occur due to abrupt temperature changes.
Altitude	3,300 ft. (1,000 m) max. [Refer to Table 2-1-2 for altitudes exceeding 3,300 ft. (1000 m.)]
Atmospheric Pressure	86 to 106 kPa
Vibration	3mm 2 to 9 Hz 9.8m/s ² 9 to 20 Hz 2m/s ² 20 to 55 Hz 1m/s ² 55 to 200 Hz

Table 2-1-2 Output attenuation ratio in relation to altitude

Altitude	Output Current Attenuation Ratio
3300 ft. (1000-1500m)	1.00
3300-4950 ft. (1000-1500m)	0.97
4950-6600 ft. (1500-2000m)	0.95
6600-8250 ft. (2000-2500m)	0.91
8250-9900 ft. (2500-3000m)	0.88

2.2 Installation Method

- (1) Mount the drive securely in the upright position on a rigid structure so that the drive keypad faces front. Avoid mounting the drive upside down or horizontally.
- (2) Allow clearances for cooling as shown in Fig. 2-2-1. This allows the drive, which generates heat during operation, to cool. The generated heat is radiated upward. Do not install the drive below a heat sensitive device.
- (3) The temperature of the heat sink rises to about 90 degrees C during operation. Mount the drive on a base made of a material able to withstand the temperature rise.

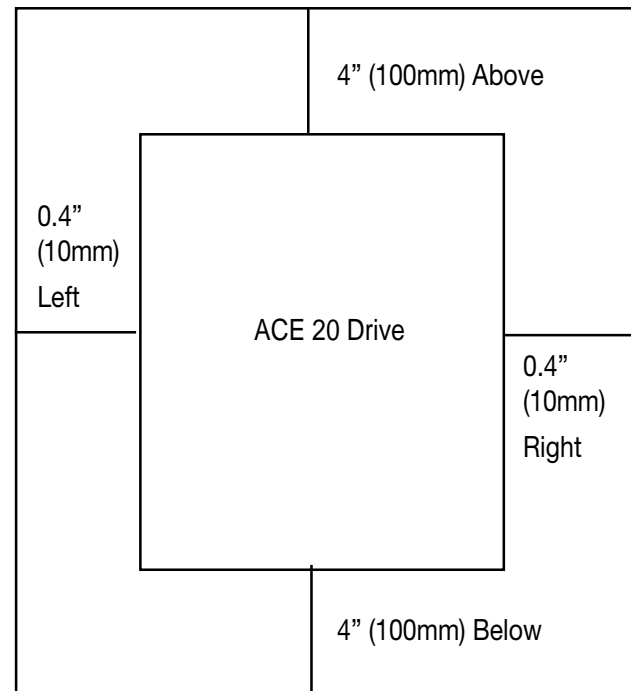

Figure 2-2-1

DANGER

Install the drive on a nonflammable material such as metal. **Otherwise, fire could occur.**

- (4) When installing the drive inside an enclosure, take ventilation into consideration, so that the ambient temperature of the drive does not exceed the specified ratings. Do not install the drive in a poorly ventilated, undersized enclosure.
- (5) When installing multiple drives inside an enclosure, horizontal installation is recommended to reduce mutual temperature effects. When a vertical layout is necessary, install a partition plate or the like between drives to isolate the heat of the lower drive.

CAUTION

Do not allow lint, paper, wood chips, dust, metallic chips or other foreign matter in the drive or allow them to remain on the heat sink.

Otherwise, a fire or an accident may occur.

2.3 Connections

Remove the control terminal block cover to connect to the control terminal block. Remove the main circuit terminal block cover to connect to the main circuit terminal block. Connect cables using the following precautions.

2-3-1 Basic Connections

- (1) Be sure to connect the power cables to the main circuit power terminals L1/R, L2/S and L3/T of the drive. If the power cables are connected to other terminals, the drive will be damaged. Check the source voltage for the allowable voltage range specified on the drive nameplate.
- (2) Connect the grounding terminal according to national and local electric codes to prevent electric shock, fire or other disasters, and to reduce electric noise. Ground must be connected.
- (3) Use reliable crimp terminals for connection of cables to the terminals.
- (4) After wiring, check the following:
 - a. Check that the cables are connected to the correct terminals.
 - b. Check that there are no bad crimps or connections.
 - c. Check that terminals or cables are not short circuited and there is no ground fault.
- (5) To change connections of a drive that has been turned on, observe the following:

The smoothing capacitor in the direct current part of the main circuit takes time to discharge after it is turned off. To avoid danger, check the DC voltage (across main circuit terminals P(+) and N(-)) for a safe voltage (25 VDC or lower) using a multi-meter after the charge lamp is off. Wait until the residual voltage is discharged before shorting a circuit, to avoid being hit by sparks caused by the voltage (electric charge).

DANGER

- Be sure to connect the grounding cable.
Otherwise, electric shock or fire could occur.
- Only qualified electricians should wire the drive.
Otherwise, electric shock could occur.
- Perform wiring only after the power supply has been turned off.
Otherwise, electric shock could occur.

Basic connection diagram

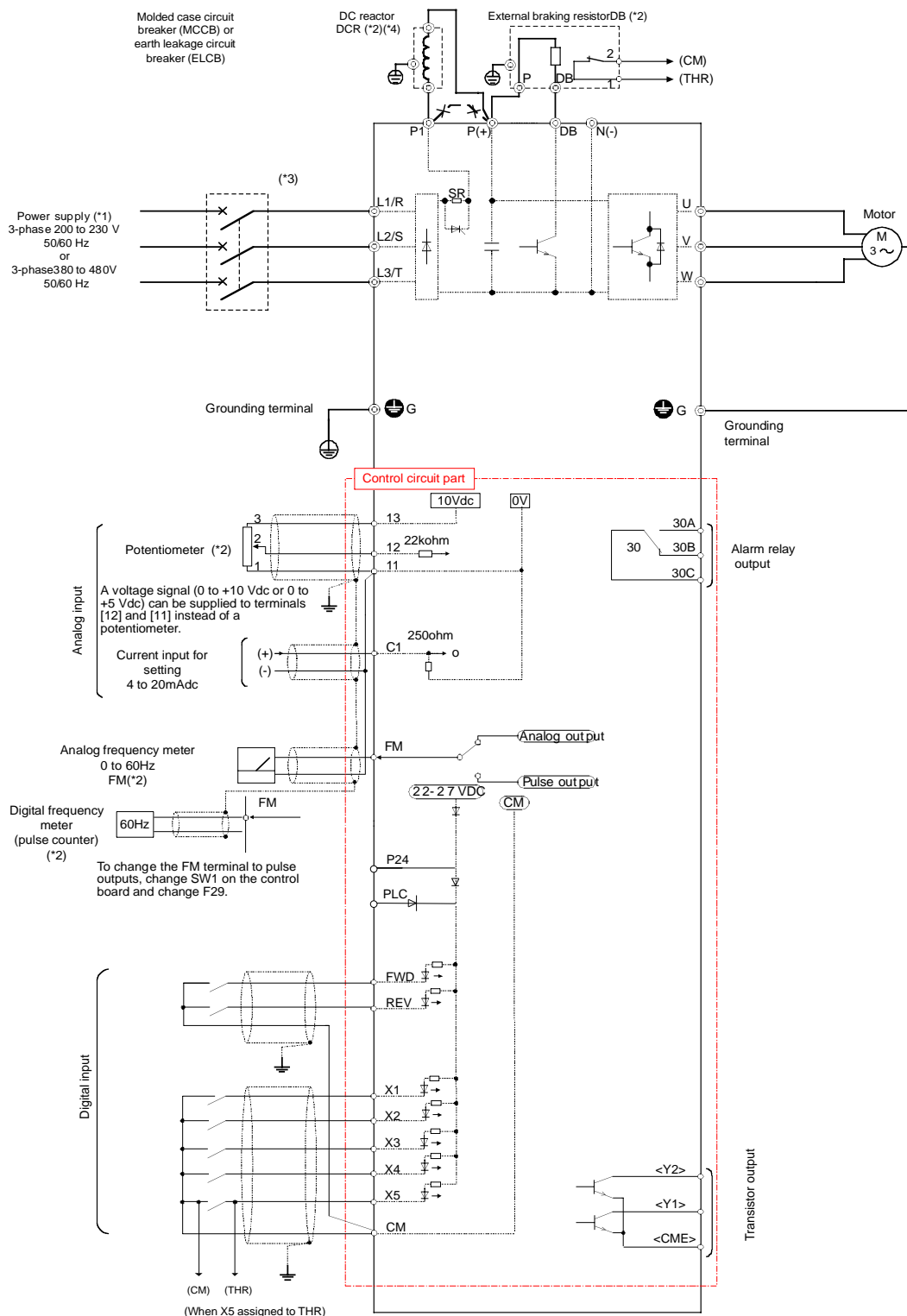

- *1) The supply voltage must be suitable for the rated voltage of the drive.
- *2) Optional part. Use when necessary.
- *3) Peripheral equipment. Use when necessary.
- *4) To connect a DC reactor (DCR) for power factor correcting, remove the jumper between the P1 and P(+) terminals.

2-3-2 Connection of Main Circuit and Grounding Terminal.

Symbol	Name of Terminal	Description
L1/R, L2/S, L3/T	Main circuit power input	Connects a 3-phase power supply
U, V, W	Output	Connects a 3-phase induction motor
P1, P(+)	DC reactor	Connects an optional DC reactor
P(+), DB	External braking resistor	Connects an optional external braking resistor
P(+), N(-)	DC link circuit terminal	Connected to DC link circuit
G	Grounding	Grounding terminal of the drive chassis (housing). Connect to the protective ground.

(1) Main circuit power terminals (L1/R, L2/S, L3/T)

- Connect these terminals to the power supply via a molded-case circuit breaker or ground-leakage circuit breaker for circuit protection. Phase-sequence matching is unnecessary.
- To ensure safety, a magnetic contactor should be used to disconnect the drive from the power supply when the drive protective function activates.
- Use control circuit terminal FWD/REV or the RUN/STOP key on the keypad panel to start and stop the motor. The main circuit power can be used to start and stop the motor only if absolutely necessary and then should not be used more than once every hour.
- If there is a need to connect these terminals to a single-phase power supply, please contact the factory.

(2) Drive output terminals (U, V, W)

- Connect these terminals to a 3-phase motor in the correct phase sequence. If the direction of motor rotation is incorrect, exchange any two of the U, V, and W phases.
- Do not connect a power factor correction capacitor or surge protector to the drive output.
- If the cable from the drive to the motor is too long, a high-frequency current may be generated by stray capacitance between the cables and result in an overcurrent trip of the drive, an increase in leakage current, or a reduction in current indication precision.

When a motor is driven by a PWM-type drive, the motor terminals and windings may be subject to surge voltage generated by drive element switching. If the motor cable (with 460V series motors, in particular) is particularly long, surge voltage will deteriorate motor insulation. To prevent this from occurring, use the following guidelines:

Drives 7-1/2 HP and larger

Motor Insulation Level	1000V	1300V	1600V
460 VAC Input Voltage	66 ft (20 m)	328 ft (100 m)	1312 ft (400 m) *
230 VAC Input Voltage	1312 ft (400 m) *	1312 ft (400 m) *	1312 ft (400 m) *

Drives 5 HP and smaller

Motor Insulation Level	1000V	1300V	1600V
460 VAC Input Voltage	66 ft (20 m)	165 ft (50 m) *	165 ft (50 m) *
230 VAC Input Voltage	328 ft (100 m) *	328 ft (100 m) *	328 ft (100 m) *

* The cable length is determined by secondary effects and not voltage spiking.

Note: When a motor protective thermal O/L relay is inserted between the drive and the motor, the thermal O/L relay may malfunction (particularly in the 460V series), even when the cable length is 165 feet (50m) or less. To correct this problem, install a filter or reduce the carrier frequency. (Use Function Code "F26 Motor Sound.")

(3) DC reactor connecting terminals (P1, P(+))

- Use these terminals to connect a DC reactor (option). Remove the jumper connected at the factory before connecting the DC reactor.
- Do not remove the jumper if no DC reactor is used.

Cut the barrier in the main circuit terminal block cover for the P1, P(+), DB and N(-) cable port using nippers or the equivalent when connecting wiring.

CAUTION

A DC reactor does not come with the drive. Use a DC reactor or AC reactor under the conditions listed below.

- When the capacity of the power supply transformer exceeds 500 kVA and exceeds 10 times the rated capacity of the drive.
- When a thyristor converter is a common load on the same transformer. If the communicating reactor is not used for the thyristor converter, an AC reactor is necessary at the drive input side.
- Used to prevent a OV trip from occurring when the phase advance capacitor in the power line is switched on and off.
- When the voltage imbalance exceeds 3%

Imbalance rate between phases [%] =

$$\frac{(\text{Max. voltage [V]} - \text{Min voltage [V]})}{3\text{-phase average voltage [V]}} = 100\%$$

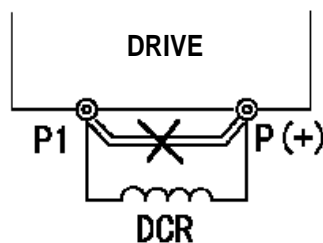
**(4) External braking resistor connecting terminals (P(+), DB)**

The drive is not equipped with a braking resistor. An external braking resistor (option) is necessary for frequent operation or heavy duty inertia load operation to enhance the braking performance.

- Connect the P(+) and DB terminals of the external braking resistor to the P(+) and DB terminals of the drive.
- Arrange devices so that the wiring length is within 16.5 ft. (5m) and the cable is twisted or tied in parallel.

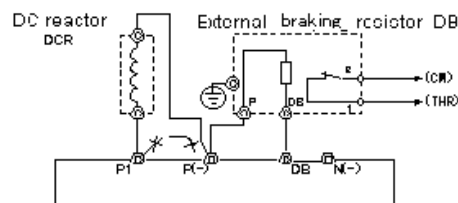
**(5) Grounding terminal (G)**

Ground the grounding terminal G for safety and noise reduction. The metallic frame of electrical equipment must be grounded in accordance with national and local electric codes to avoid electric shock, fire and other disasters.

CAUTION

- Check that the number of phases and the rated voltage of the drive agree with the number of phases and the voltage of the AC power supply.
- Do not connect the AC power cables to the output terminals (U, V, W). **Otherwise, injuries could occur.**
- Do not connect a braking resistor directly to the DC terminals (P(+), N(-)). **Otherwise, fire could occur.**

2-3-3 Connection of Control Terminals

Table 2-3-2 shows the functions of the control circuit terminals. The method of connecting control terminals varies according to the function setting. Refer to the connection method for the function.

Table 2-3-2 Functions of control circuit terminals

Classification	Terminal Symbol	Terminal Name	Description of Function																								
Analog Input	13	Potentiometer power supply	+10 VDC power supply for frequency setting POT. G1 (POT: 5k ohms)																								
	12	Voltage input	(1) The frequency is set according to the external analog input voltage command. 0 to +10 VDC / 0 to 100% Reversible operation using +/- signal: 0 to +/-10 VDC / 0 to 100% Inverse mode operation: +10 to 0 VDC / 0 to 100% (2) The PID control feedback signal input. * Input resistance: 22k ohms																								
	C1	Current input	(1) The frequency is set according to the analog input current command. 4 to 20 mA DC / 0 to 100% Inverse mode operation: 20 to 4 mA DC/ 0 to 100% (2) The PID control feedback signal input. * Input resistance: 250 ohms																								
	11	Common	Common for analog signals																								
Digital Input	FWD	Forward operation command	Forward operation with FWD-CM ON, and deceleration and stop with FWD-CM OFF																								
	REV	Reverse operation command																									
	X1	Digital input 1	A coast-to-stop command from an external device, external alarm, alarm reset, multi-step frequency selection and other functions can be assigned to the X1 through X5 terminals.																								
	X2	Digital input 2																									
	X3	Digital input 3																									
	X4	Digital input 4																									
	X5	Digital input 5																									
			<Digital input circuit specification>																								
			<table border="1"> <thead> <tr> <th colspan="2">Item</th> <th>Minimum</th> <th>Type</th> <th>Maximum</th> </tr> </thead> <tbody> <tr> <td rowspan="2">Operation voltage</td> <td>Level ON</td> <td>0V</td> <td>—</td> <td>2V</td> </tr> <tr> <td>Level OFF</td> <td>22V</td> <td>24V</td> <td>27V</td> </tr> <tr> <td colspan="2">Operation current at ON</td> <td>—</td> <td>4.2mA</td> <td>6mA</td> </tr> <tr> <td colspan="2">Allowable leakage current at OFF</td> <td>—</td> <td>—</td> <td>0.5mA</td> </tr> </tbody> </table>	Item		Minimum	Type	Maximum	Operation voltage	Level ON	0V	—	2V	Level OFF	22V	24V	27V	Operation current at ON		—	4.2mA	6mA	Allowable leakage current at OFF		—	—	0.5mA
	Item		Minimum	Type	Maximum																						
	Operation voltage	Level ON	0V	—	2V																						
Level OFF		22V	24V	27V																							
Operation current at ON		—	4.2mA	6mA																							
Allowable leakage current at OFF		—	—	0.5mA																							
PLC	PLC terminal		The output signal power supply of the PLC. (Rated voltage: 24 VDC)																								
CM	Common		Common for digital input																								

Classification	Terminal Symbol	Terminal Name	Description of Function																								
Analog output/Pulse output	FM (11: Common terminal)	Analog monitor	<p>The monitored signal is output as 0 to 10 VDC. The signal can be selected from the following:</p> <ul style="list-style-type: none"> Output frequency 1 (before slip compensation) Output frequency 2 (after slip compensation) Output current Output torque Input power DC link circuit voltage Output voltage Load factor PID feedback value <p>* Allowable connection impedance: 5 k ohms minimum</p>																								
		Pulse rate monitor	<p>The monitored signal is output according to the pulse voltage. The signal description is the same as the FMA signal. * Allowable connection impedance: min. 5 k ohm. Use SW1 on the control board and Function Code F29 to change between the analog monitor and pulse rate monitor. (FMA: analog monitor, FMP: pulse rate monitor).</p>																								
Transistor output	Y1	Transistor output 1	<p>The Run signal, frequency equivalence signal, overload early warning signal and other signals are output to a transistor output.</p> <p><Transistor output circuit specification></p> <table border="1"> <thead> <tr> <th colspan="2">Item</th> <th>Minimum</th> <th>Type</th> <th>Maximum</th> </tr> </thead> <tbody> <tr> <td rowspan="2">Operation voltage</td> <td>Level ON</td> <td>—</td> <td>1V</td> <td>2V</td> </tr> <tr> <td>Level OFF</td> <td>—</td> <td>24V</td> <td>27V</td> </tr> <tr> <td colspan="2">Maximum load current at ON</td> <td>—</td> <td>—</td> <td>50 mA</td> </tr> <tr> <td colspan="2">Leakage current at OFF</td> <td>—</td> <td>—</td> <td>0.1mA</td> </tr> </tbody> </table>	Item		Minimum	Type	Maximum	Operation voltage	Level ON	—	1V	2V	Level OFF	—	24V	27V	Maximum load current at ON		—	—	50 mA	Leakage current at OFF		—	—	0.1mA
	Item			Minimum	Type	Maximum																					
	Operation voltage	Level ON		—	1V	2V																					
		Level OFF		—	24V	27V																					
Maximum load current at ON		—	—	50 mA																							
Leakage current at OFF		—	—	0.1mA																							
Y2	Transistor output 2																										
CME	Common (Transistor output)	Common for transistor output signal. Isolated from terminals CM and 11.																									
P24 (CM: common terminal)	DC voltage supply	Power supply for transistor output load. (24 Vdc 50 mAdc Max.) (When using P24, short the CM and CME terminals.) (If the P24 terminal is overloaded or connected with the CM terminal, the drive trips with Er3 indication. To reset, remove external causes and, after several minutes, turn the drive on again.)																									
Relay output	30A,30B, 30C	Alarm relay output	<p>When the drive is stopped with an alarm, a relay contact output (1C) is issued.</p> <p>Contact capacity: 250 VAC, 0.3A cos = 0.3 When complying with low voltage directive: 48 VDC, 0.5A When complying with UL/cUL: 42 VDC, 0.5A Selection between excitation upon an alarm or excitation during normal operation is allowed.</p>																								

(1) Analog input terminals (13, 12, C1, 11)

- a. Because analog signals are normally low voltage, they are especially susceptible to external noise effects. Route the wiring as short as possible (within 20m (66 ft)) and use shielded cables. Ground the shield of the shielded cable. If effects of external inductive noises are considerable, connection to Terminal 11 may be effective.
- b. Use a twin-contact relay for weak signals if a relay is used in the circuit. However, do not add a contact to Terminal 11.
- c. When the drive is connected to an external device outputting the analog signal, a malfunction may be caused by electric noise generated by the drive according to the circuit connection of the connected device. If this happens, connect a ferrite core or capacitor to the device outputting the analog signal.

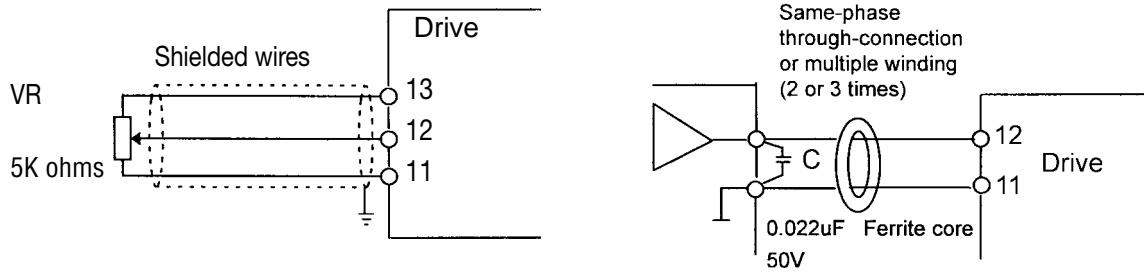

(2) Digital input terminals (FWD, REV, X1 through X5, PLC, CM)

- a. Generally, the digital input terminals (FWD, REV, X1-5) are turned on or off in relation to the CM terminal. When the terminals are turned on or off at the open collector output using an external power supply, malfunctions may be caused due to a routing circuit. If this happens, use the PLC terminal as shown in Table 2-3-2.
- b. To use the contact input, use a reliable contact, free from corrosion and debris.

(3) Transistor output terminals (Y1-Y2, CME)

- a. Circuit configuration shown in Table 2-3-2 for transistor output is used. Note the polarity of the external power supply.
- b. To connect a control relay, connect a surge protecting diode across the coil of the relay.

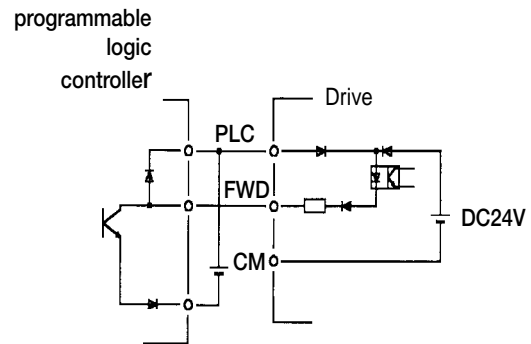

Prevention of Bypass Current by External Power

(4) Others

- a. Route the wiring of the control terminals as far from the wiring of the main circuit as possible. **Otherwise, electric noise may cause malfunctions.**
- b. Fix the control cables inside the drive to keep them away from the live parts of the main circuit (such as the terminal block of the main circuit).

DANGER

If the control cables touch the live part of the main circuit, the insulation sheath of the control cable may be damaged and cause the high voltage of the main circuit to be fed to the control signal. This is not permissible in the low voltage directive models for Europe. **Electric shock could occur.**

CAUTION

Electric noise may be generated by the drive, motor or wiring. Note the possible malfunctions of nearby sensors and devices due to noise. **An accident could occur.**

2.3.4 Terminal Layout

(1) Main circuit terminal block

Catalog Number
 ACE202V3P0001N1
 ACE202V3P0002N1
 ACE202V3P0005N1
 ACE202V3P0010N1

Main circuit terminal drawing

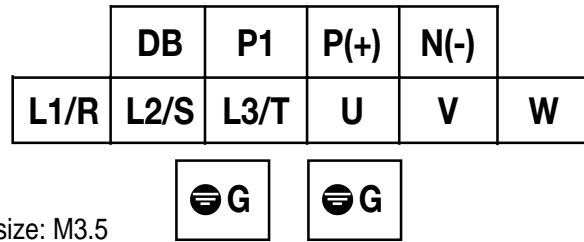

Screw size: M3.5

ACE202V3P0020N1
 ACE202V3P0030N1
 ACE204V3P0005N1
 ACE204V3P0010N1
 ACE204V3P0020N1
 ACE204V3P0030N1

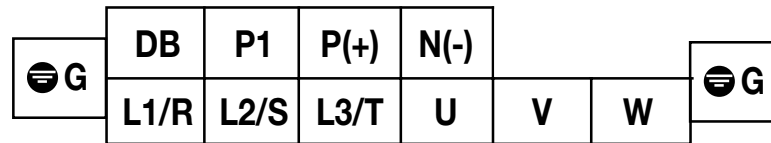

Screw size: M4

ACE202V3P0050N1
 ACE202V3P0075N1
 ACE202V3P0100N1
 ACE204V3P0050N1
 ACE204V3P0075N1
 ACE204V3P0100N1

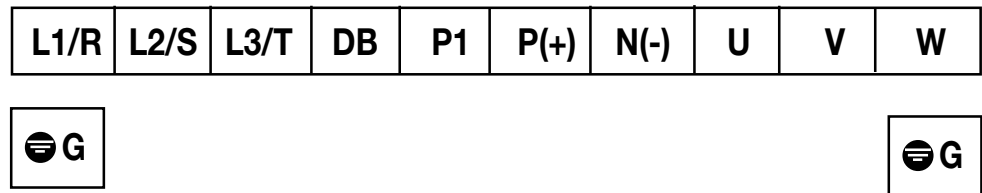

Screw size: M4

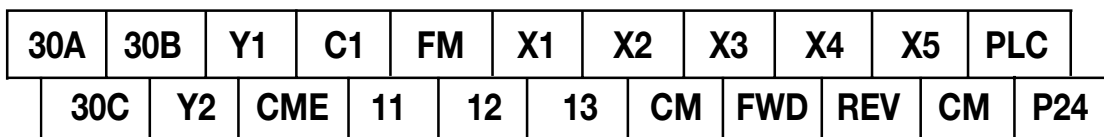

(2) Control terminal block

Screw size: M2.5

Tightening torque: 3.5 lb•Inch (0.4 N•m)

Note: Refer page to v for cable size, tightening torque and incoming device rating.

Notes:

3. Operation

3.1 Inspection and Preparation Before Operation

Check the following before starting operation.

- (1) Check if all power and control connections are correct.
Especially check if the motor power cables are connected to output terminals U, V and W and that the grounding cable is grounded.
Note: Operation can be checked before connecting the motor.
- (2) Check for short circuits between terminals, exposed live parts, and ground faults.
- (3) Check for loose terminals, connectors and screws.
- (4) Check if the motor is separated from mechanical equipment.
- (5) Turn the switches off so that the motor does not start or operate at power-on.
- (6) After the power is turned on, check the following.
 - a. Check if the keypad panel shows an alarm.
 - b. Check if the fan built in the drive rotates. (2 HP or above)

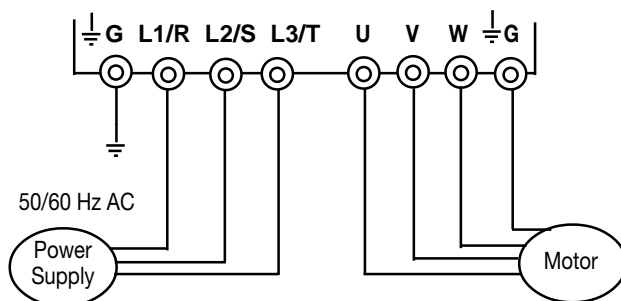

Fig. 3-1-1

Drive connection diagram

DANGER

- Be sure to install the terminal cover before turning on the power. Do not remove the cover during power application.
- Do not operate switches with wet hands.
Otherwise, electric shock could occur.

Note: The AC power supply must not be connected to terminals U, V and W.

3.2 Operation Method

There are various operation methods. Refer to chapter 4 “Keypad Panel” and chapter 5 “Selecting Functions” to select the method most suitable for the application and operation specification. Table 3-2-1 shows general operation methods.

Table 3-2-1 General operation methods

Operation Method	Frequency Setting	Operation Command
Operation using keypad panel	Keypad panel keys ▲ ▼	Keypad panel keys RUN STOP
Operation using external signal terminal	▲ ▼	Contact input (switch), terminals FWD-CM, terminals REV-CM
	Potentiometer or analog voltage, current or multistep speed operation	

3.3 Test Operation

After checking for errors in section 3-1, perform a test operation.

When shipped from the factory, the drive is in the keypad panel operation mode.

- (1) Turn the power on and check that the LED blinks while indicating 0.00 Hz frequency.
- (2) Using the ▲ key, set the frequency to a low frequency, such as 5 Hz.
- (3) Press the RUN key to start operation. To stop, press the STOP key.
- (4) Check the following.
 - a. Check if the direction of rotation is correct.
 - b. Check for smooth rotation without motor humming or excessive vibration.
 - c. Check for smooth acceleration and deceleration.
- (5) Using Function Code P04 Motor 1 (auto tuning), tune the motor constant.

If no abnormality is found, increase the operation frequency to check for full speed range operation.

After checking for correct operation during the above test operation, start normal operation.

Caution 1:

If any operation abnormality is found, immediately stop operation and determine the cause by referring to chapter 7, Troubleshooting.

Caution2:

If voltage is applied to the L1/R, L2/S and L3/T main circuit power supply terminals, even after the motor stops, the drive output terminals U, V and W will have voltage present and can cause electric shock when the terminals are touched. Also, the smoothing capacitor does not discharge immediately after the power is turned off. It takes time for the capacitor to discharge and voltage is present.

Before touching an electric circuit, after turning the power off, check that the charge lamp is not lit and check for safe voltage using a multimeter checking the various power circuit connections.

4. Keypad Panel

The keypad panel provides various functions, such as operation (frequency setting and start/stop commands), monitor and alteration of function code data, and various confirmation functions.

Be familiar with the operation method of each function before starting operation.

4.1 Appearance of Keypad Panel

Digital display

Various function codes and data codes for programming will be shown. The output frequency, output current and other data will be displayed during operation, and the cause of trouble will be displayed using codes.

Unit and operation mode display

The unit of the data displayed at the digital display is indicated with an LED. The program mode is indicated. The PANEL CONTROL lamp lights in the keypad panel operation mode.

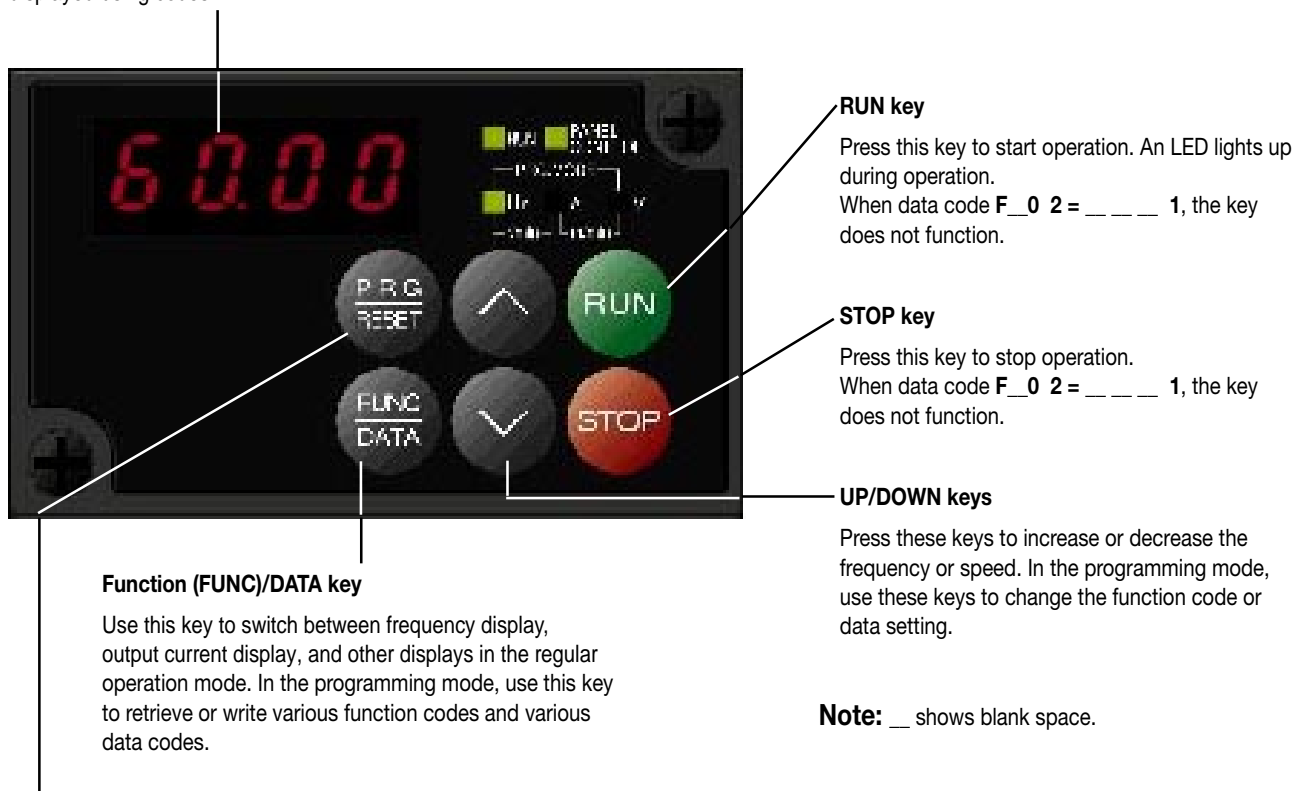

Program (PRG)/RESET key

Press this key to switch between the regular operation mode and programming mode. Use this key to reset an alarm stopping state after activation of a protective function.

(1) Monitor switching method

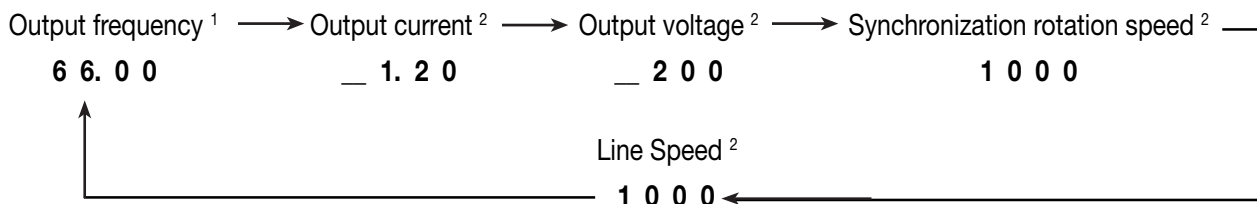

In the regular operation mode, press the key to switch between frequency display, output current display, and other displays.

1: In the PID control mode (when function H20 is at “1” or “2”), the value is in the percent display and the dot at the least significant digit always lights.

Example: 10%: _ 1 0. 0. , 100%: 1 0 0. 0.

2: Press the , key during display of data to display the frequency setting.

(2) Stopping

Operation is started when the **RUN** is pressed, and is stopped when the **STOP** is pressed when function **F — 0 2** is set to **— — — 0**, **— — — 1** or **— — — 3**.

The direction of rotation is Forward with FWD-CM ON, and Reverse with REV-CM ON.

(3) Changing the frequency

The frequency increases when the **▲** key is pressed and decreases when the **▼** key is pressed while function **F — 0 1** is set to **— — — 0**

The speed change increases when the **FUNC DATA** key is pressed at the same time as the **▲** or **▼**

Note: Do not turn the power off for five seconds after performing a monitor change or function setting; otherwise, Er1 will occur.

(4) Function setting method

Description of Operation	Operation Procedure	Display Result
Initial condition.		6 0. 0 0
Start the program mode.	Press the PRG RESET key.	F — 0 0
Select a setting or monitoring function.	Press the ▲ or ▼ key.	F — 0 1
Have the data displayed.	Press the FUNC DATA key.	— — — 1
Change the data.	Press the ▲ or ▼ key.	— — — 2
Store the data.	Press the FUNC DATA key.	F — 0 2
Exit from the program mode. (Or select another function.)	Press the PRG RESET (Press the ▲ or ▼ key)	6 0. 0 0

Note: **_** shows blank space.







(5) Changing the function code

The function code consists of an alphabetic character and a number. The alphabetic character is defined for each of the function groups.

Table 4-1-1 Major groups of function codes

Function Code	Function
F00 - F42	Fundamental functions
E01 - E41	Extension terminal functions
C01 - C33	Control functions of frequency
P01 - P10	Motor parameters
H01 - H46	High performance functions
A01 - A19	Alternative motor parameters

The function code changes each time the  or  key is pressed. (Press and hold the  or  key to continue changing the function code.)

While pressing and holding the  or  key during function code change, press the  key to change to the next group with another alphabetic character. (Press the  and  keys to jump to the top of the F, E, C, P, H or A code, or press the  and  key to jump to the last of the F, E, C, P, H or A code.)

Changing example:

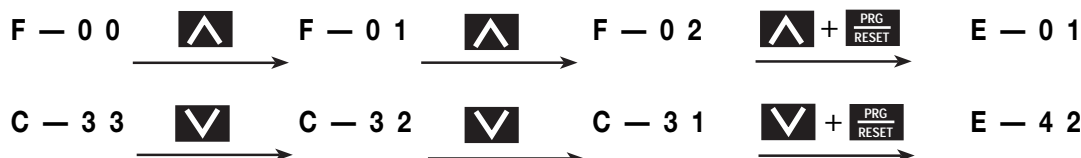







4-1-1 Alarm Occurrence

When an alarm occurs, the description of the alarm is displayed.

Press the  or  key during the alarm display to display the latest three alarms.

To display the previous four alarms, select H02 Trip history.

4-1-2 Digital Frequency Setting Method

Press the  or  key with the operation mode screen selected. The LED displays changes made to the frequency setting. The displayed data increases or decreases with the unit of the least increment first. While the  or  key is held down, the changing digit moves to the upper order for easy increased rate of change. Further, while pressing and holding the  or  key, and pressing the  key, the rate of speed change will increase.

No special operation is necessary to store the new frequency setting. The setting is automatically stored when the drive is turned off.

4.2 Operation Methods

The following table lists three common operation methods. Examples of these operation methods are described on the following three pages.

Operation Method	Reference (Motor Speed)	Description	Page
Keypad	Keypad	This method requires no external wiring connections to the drive, and is commonly used for initial startup, testing, and out of the box configuration	4-4
2-Wire	4-20 mA DC	This method allows the motor to be started and stopped from a remote location, and the reference is supplied by a 4-20 mA DC signal from, for example, a PLC.	4-5
3-Wire	Speed Pot or 0-10 VDC	This method allows the motor to be started and stopped from a remote location, and the reference is supplied by a 5K ohm potentiometer or an external 0-10 VDC supply from, for example, a process controller.	4-6

Example 1: Start/Stop and Speed Changes from the Keypad (Factory Default)

When the drive is set up for start/stop functions and speed changes to be made from the keypad, it is considered local mode. Local mode is most often used during initial start-up to check the motor operation and rotation of the shaft. The drive is defaulted to local mode out of the box.

Operation

The frequency reference (speed changes) from the **UP** and **DN** keys located on the keypad.

The drive can be started by pressing the **RUN** key and stopped by pressing the **STOP** key on the keypad.

Programming Needed to Operate from the Keypad

Parameter	Display (Readout)	Description
F01	0	Frequency Command (speed change) from the keypad.
F02	0	Operation Command (start/stop) from the keypad.
F07/08	xx.x seconds	Acceleration and deceleration times. The time from stop to full speed and from full speed to stop.
F11	Motor full load Amps (FLA)	Enter the motor's FLA from the nameplate on the motor.

Example 2: Remote Start/Stop (2-wire) & Speed Changes from an External Source

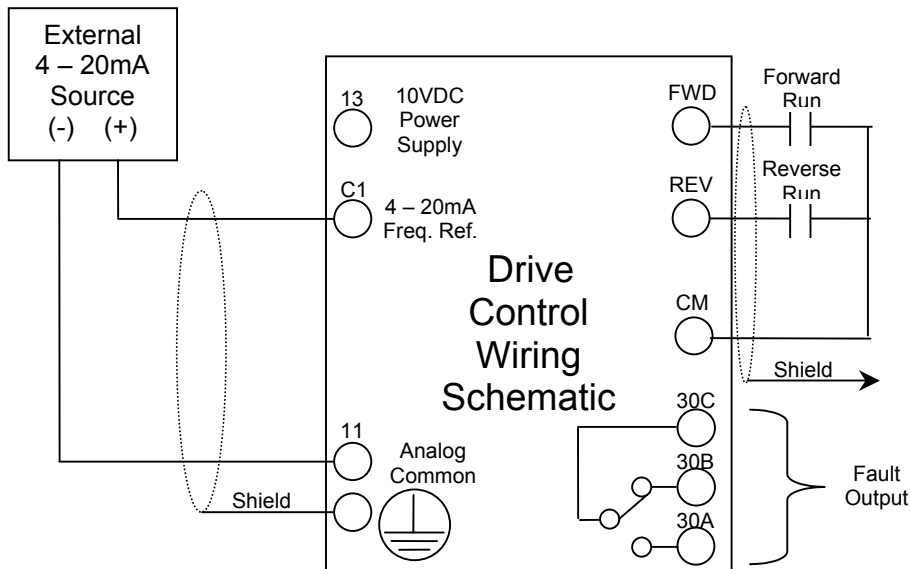

The above configuration is commonly used when the start/stop and the speed changes are supplied by a remote supply such as a PLC and relays. It can be used with a maintained switch when it is desirable to have the motor restart on restoration of power. It should not be used where safety of attending personnel might be threatened by a restart. A speed potentiometer may be used in this configuration by connecting the "100 end" to 13, the wiper to 12 and the zero end to 11. (5k ohms, 1/4 watt minimum with shielded wiring.)

Programming Needed for 2-wire Start/Stop and Speed Changes from an External Source

Parameter	Display (Readout)	Description
H03	1 (Hold STOP and UP key to change) Press the FUNC/DATA Key.	Resets all parameters to factory setting for a 2-wire configuration. (Caution: all previous settings will be lost.) Once 1 is entered, the settings will return to their factory setting of 0.
F01	2	Frequency command (speed changes) via Terminal C1.
F02	1	Operation Method (start/stop) via terminals.
F07/F08	xx.x Seconds	Accelerating time and Deceleration time / The time from stop to full speed and from full speed to stop.
F11	Motor Full Load Amps (FLA)	Enter the motor's FLA from the nameplate on the motor.
F01 (OPTIONAL)	1	Program this parameter ONLY if speed changes are to be by remote speed pot via Terminal 12. Power source for the pot is Terminal 13. Pot value recommended is 5K ohms.

Notes:

The rotation depends on the FWD and REV terminals, as follows:

FWD to CM connected runs forward direction.

REV to CM connected runs in reverse direction.

No operation occurs when both FWD and REV terminals are connected or no connection is made to CM terminal.

Example 3: Remote Start/Stop/Speed Control (3-wire) from External Source

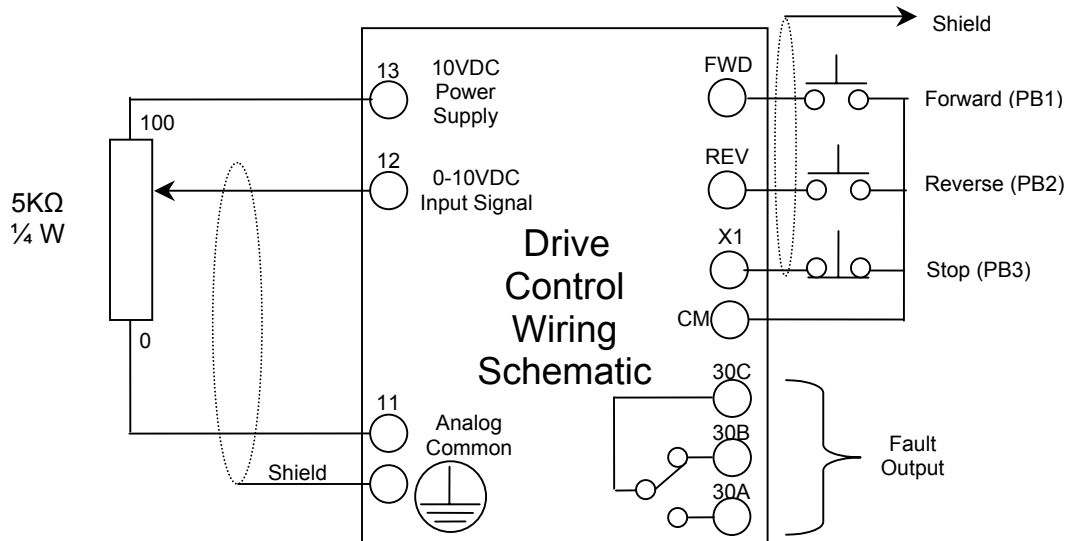

This configuration is common when the drive has replaced a contactor in an existing application and an operator must vary the speed from an external speed pot. It is recommended that the potentiometer value be 5k ohms with a minimum wattage of ¼ watt, and that shielded wiring be used.

Operation

Pushing Push-button PB1 momentarily enables the motor to start in the forward direction.
 Pushing Push-button PB2 momentarily enables the motor to start in the reverse direction.
 Pushing Push-button PB3 any time will stop the motor.
 The speed changes are proportional to the input signal at terminal 12.

Programming for 3-wire Start/Stop and External Source

Parameter	Display (Readout)	Description
E01	5	Configures the FWD, REV, and X1 terminals to accept 3-wire start/stop control logic.
F01	1	Frequency Command (speed change) via terminal 12.
F02	1	Operation Method (start/stop) via terminals.
F07/F08	xx.x Seconds	Accelerating time and Deceleration time / The time from Stop to full speed and from full speed to stop.
F11	Motor Full Load Amps (FLA)	Enter the motor's FLA from the nameplate on the motor.

4.3 Recalibration Instructions For ACE202V3P0001N1 Drives

The ACE202V3P0001N1 Drive has been calibrated at 1/8HP by the factory. However, if this drive is reset to factory settings, the drive will be calibrated at 1/4HP, and must be recalibrated for proper motor protection. To recalibrate the drive, set the four parameters as shown in the following table.

Catalog No.	Parameter Settings			
	F11 OL Level (Amps)	F12 OL Time Constant (Minutes)	P02 Motor Capacity (HP)	P03 Motor Rated Current (Amps)
ACE202V3P0001N1 (230V, 1/8HP)	.71	1.5	.13	.71

Notes:

5. Selecting Functions

5.1 Function Selection List

F: Fundamental functions						
Function Code	Name	Setting Range	Min. Unit	Factory Setting	Change During Operation	User Setting
F00	Data protection	0: Data change enabled 1: Data protected	1	0	N	
F01	Frequency command 1	0: Keypad operation 1: Voltage input (terminal 12) 2: Current input (terminal C1) 3: Voltage and current input 4: Voltage input with polarity 5: Voltage input inverse mode operation (terminal 12) 6: Current input inverse mode operation (terminal C1) 7: UP/DOWN control mode 1 8: UP/DOWN control mode 2	1	0	N	
F02	Operation method	0: Keypad operation 1: Terminal operation (STOP key active) 2: Terminal operation (STOP key inactive) 3: Terminal operation (STOP key active with special software) 4: Terminal operation (STOP key inactive with special software)	1	0	N	
F03	Maximum frequency 1	50 to 400 Hz	1 Hz	60	N	
F04	Base frequency 1	25 to 400 Hz	1 Hz	60	N	
F05	Rated voltage 1 (at Base frequency)	0V: Output voltage is proportional to the source voltage 80 to 240V (230V class) 160 to 480V (460V class)	1V	230 460	N	
F06	Maximum voltage 1 (at Maximum frequency)	80 to 240V (230V class) 160 to 480V (460V class)	1V	230 460	N	
F07	Acceleration time 1	0.01 to 3600 seconds	0.01s	6.0	Y	
F08	Deceleration time 1	0.01 to 3600 seconds	0.01s	6.00	Y	
F09	Torque boost 1	0: Automatic torque boost 1: Variable speed (fans/pumps) torque characteristics 2: Proportional torque characteristics 3 to 31: Constant torque characteristics	1		Y	
F10	Electronic thermal overload relay for motor 1 (Select)	0: Inactive 1: Active (for general purpose motors) 2: Active (for forced air extended operating range motors)	1	1	Y*	
F11	(Level)	20 to 135% of the rated motor current	0.01A	rated motor current	Y	
F12	(Thermal time constant)	0.5 to 10.0 min.	0.1 min	5.0	Y	
F13	Electronic thermal overload relay (for braking resistor)	0: In active 1: Active (for external braking resistor up to 5 HP) 2: Active (for external braking resistor 7-1/2 / 10 HP)	1	0	N	
F14	Restart mode after momentary power failure	0: Inactive (The drive trips immediately) 1: Inactive (The drive trips after the power failure recovers) 2: Active (The drive restarts at the frequency prior to power failure) 3: Active (The drive restarts at the starting frequency)	1	0	N	
F15	Frequency limiter (High)	0 to 400 Hz	1 Hz	70	Y	
F16	(Low)			0	Y	
F17	Gain (For frequency setting)	0.0 to 200.0%	0.10%	100	Y	
F18	Bias frequency	-400 to +400 Hz	1 Hz	0	Y	
F20	DC Brake (Starting frequency)	0.0 to 60.0 Hz	0.1 Hz	0.0	Y	
F21	(Braking level)	0 to 100%	1%	0	Y	
F22	(Braking time)	0.0 second (Inactive) 0.1 to 30.0 seconds	0.1s	0.0	Y	
F23	Starting frequency (Frequency)	0.1 to 60.0 Hz	0.1s	0.5	N	
F24	(Holding time)	0.0 to 10.0 seconds	0.1 Hz	0.0	N	
F25	Stop frequency	0.1 to 6.0 Hz	0.1 Hz	0.2	N	
F26	Motor sound (Carrier frequency)	0.75,1 to 15 kHz	1 kHz	2	Y	
F27	(Sound tone)	0 to 3	1	0	Y	

Y: The data can be changed with the UP or DOWN arrow key during operation. However, press the FUNC/DATA key to store the new data.

Y*: Press the UP or DOWN arrow key to change data. The new data takes effect after the FUNC/DATA key is pressed to store the data.

N: Data can be changed only while the motor is stopped.

F: Fundamental functions (continued)						
Function Code	Name	Setting Range	Min. Unit	Factory Setting	Change During Operation	User Setting
F29	FMA and FMP terminals (Select)	0: Analog output (FMA) 1: Pulse train output (FMP)	1	0	N	
F30	FMA (Voltage adjust)	0 to 200%	1%	100	Y	
F31	(Function)	0: Output frequency 1 1: Output frequency 2 2: Output current 3: Output voltage 4: Output torque 5: Load factor 6: Input power 7: PID feedback value 8: DC link circuit voltage	1	0	Y*	
F33	FMP (Pulse rate)	300 to 6000 p/s (Pulse count at 100%)	1 p/s	1440	Y	
F34	(Voltage adjust)	0%, 1 to 200%	1%	0	Y	
F35	(Function)	0 to 8 (Same as F31)	1	0	Y*	
F36	30Ry	0: Activated when tripped 1: Activated during regular operation	1	0	N	
F40	Torque limiter 1 (Driving)	20 to 200% 999: Inactive	1%	999	Y	
F41	(Braking)	0%: Automatic deceleration control 20 to 200% 999: Inactive	1%	999	Y	
F42	Torque vector control 1	0: Inactive 1: Active	1	0	N	
E: Extension terminal functions / Digital Input/Output functions						
E01	X1 terminal function	0: Multistep frequency 1: Multistep frequency 2: Multistep frequency 3: Multistep frequency	1	0	N	
E02	X2 terminal function	4: Acceleration/deceleration time selection [RT1] 5: 3-wire operation stop command [HLD] 6: Coast-to-stop command [BX] 7: Alarm reset [RST]		1	N	
E03	X3 terminal function	8: Trip command (External fault) [THR] 9: Frequency setting 2 / Frequency setting 1 10: Motor 2 / Motor 1 [M2/M1] 11: DC brake command [DCBRK]		2	N	
E04	X4 terminal function	12: Torque limit 2 / Torque limit 1 [TL2/TL1] 13: UP command [UP] 14: DOWN command [DOWN] 15: Write enable for keypad		6	N	
E05	X5 terminal function	16: PID control cancel [Hz/PID] 17: Inverse mode changeover [IVS] (Terminals 12 and C1) 18: Communications link enable [LE]		7	N	
E10	Acceleration time 2	0.01 to 3600 seconds	0.01 second	10.0	Y	
E11	Deceleration time 2					
E16	Torque limiter 2 (Driving)	20 to 200% 999: Inactive	1%	999	Y	
E17	(Braking)	0%: Automatic deceleration control, 20 to 200% 999: Inactive	1%	999	Y	
E20	Y1 terminal function	0: Drive run [RUN] 1: Frequency arrival at setpoint (FAR) 2: Frequency level detection 3: Under voltage detection signal [LV] 4: Torque polarity	1	0	N	
E21	Y2 terminal function	5: Torque limiting [TL] 6: Auto restarting [IPF] 7: Overload early warning [OL] 8: Life time alarm [LIFE] 9: Frequency arrival at setpoint (FAR2)		7		

Y: The data can be changed with the UP or DOWN arrow key during operation. However, press the FUNC/DATA key to store the new data.

Y*: Press the UP or DOWN arrow key to change the data. The new data will take effect after the FUNC/DATA key is pressed to store the data.

N: The data can be changed only while the motor is stopped.

E: Extension terminal functions / Digital Input/Output functions (continued)						
Function Code	Name	Setting Range	Min. Unit	Factory Setting	Change During Operation	User Setting
E29	Frequency detection delay	0.01 to 10.0 seconds	0.01s	0.10	Y	
E30	FAR function signal (Hysteresis)	0.0 to 10.0 Hz	0.1 Hz	2.5	Y	
E31	FDT function signal (Level)	0 to 400 Hz	1 Hz	60	Y	
E32	(Hysteresis)	0.0 to 30.0 Hz	0.1 Hz	1.0	Y	
E33	OL function signal (Mode select)	0: Electronic thermal overload relay 1: Output current	1	0	Y*	
E34	(Level)	20 to 200% of the rated motor current	0.01A	Rated motor current	Y	
E35	(Timer)	0.0 to 60.0 seconds	0.1s	10.0	Y	
E40	Display (A)	0.00 to 200.0	0.01	0.01	Y	
E41	(B)	0.00 to 200.0	0.01	0.00	Y	
E42	LED display	0.0 to 5.0 seconds	0.1s	0.5	Y	
C: Control function of frequency						
C01	Jump frequency (Jump frequency 1)	0 to 400 Hz	1 Hz	0	Y	
C02	(Jump frequency 2)			0	Y	
C03	(Jump frequency 3)			0	Y	
C04	(Hysteresis)	0 to 30 Hz		3	Y	
C05	Multistep frequency (Frequency 1)	0.00 to 400.0 Hz	0.01 Hz	0.00	Y	
C06	(Frequency 2)					
C07	(Frequency 3)					
C08	(Frequency 4)					
C09	(Frequency 5)					
C10	(Frequency 6)					
C11	(Frequency 7)					
C12	(Frequency 8)					
C13	(Frequency 9)					
C14	(Frequency 10)					
C15	(Frequency 11)					
C16	(Frequency 12)					
C17	(Frequency 13)					
C18	(Frequency 14)					
C19	(Frequency 15)					
C21	Timer operation auto-stop	0: Inactive 1: Active	1	0	N	
C22	Auto-stop time	0.00 to 3600 seconds	0.01s	0.00	Y	
C30	Frequency command 2	0 to 8 (same as F01)	1	2	N	
C31	Analog setting signal offset adjustment (Terminal 12)	-5.0 to +5.0%	0.1%	0.0	Y	
C32	(Terminal C1)	-5.0 to +5.0%	0.1%	0.0	Y	
C33	Analog setting signal filter	0.00 to 5.00 seconds	0.01s	0.05	Y	
P: Motor parameters						
P01	Number of motor 1 poles	2 to 14	2	4	N	
P02	Motor 1 (Capacity)	0.01 to 7.5 HP (5 HP or less) 0.01 to 15 HP (7-1/2/10 HP)	0.01 HP	Nominal applied motor HP	N	
P03	(Rated current)	0.00 to 99.9A	0.01A	Standard rating	N	
P04	(Tuning)	0: Inactive 1: Active (%R1, %X) 2: Active (%R1, %X, Io)	1	0	N	
P05	(Online tuning)	0: Inactive 1: Active	1	0	N	

Y: The data can be changed with the UP or DOWN arrow key during operation. However, press the FUNC/DATA key to store the new data.
Y*: Press the UP or DOWN arrow key to change the data. The new data will take effect after the FUNC/DATA key is pressed to store the data.
N: The data can be changed only while the motor is stopped.

Function Code	Name	Setting Range	Min. Unit	Factory Setting	Change During Operation	User Setting															
P: Motor parameters (continued)																					
P06	(No-load current)	0.00 to 99.9A	0.01A	standard rating	N																
P07	(%R1 setting)	0.00 to 50.00%	0.01%	standard rating	Y																
P08	(%X setting)	0.00 to 50.00%	0.01%	standard rating	Y																
P09	(Slip compensation control 1)	0.00 to 15.0 Hz	0.01 Hz	0.00	Y																
P10	(Slip compensation response time 1)	0.01 to 10.00 seconds	0.01s	0.50	Y																
H: High performance functions																					
H01	Total operating time	Monitor only	10h	0	—																
H02	Trip history	Monitor only	—	—	—																
H03	Data initializing (Data reset)	0: Disabled 1: Initialize data functions	1	0	N																
H04	Auto-reset (Times)	0: Inactive 1 to 10 times	1 time	0	Y																
H05	(Reset interval)	2 to 20 seconds	1s	5	Y																
H06	Fan stop operation	0: Inactive 1: Active	1	0	Y																
H07	ACC/DEC pattern (Mode select)	0: Linear acceleration/deceleration 1: S-curve acceleration/deceleration (weak) 2: S-curve acceleration/deceleration (strong) 3: Non-linear	1	0	N																
H09	Start mode (Rotating motor pickup mode)	0: Inactive 1: Active (After momentary power failure) 2: Active (All start modes)	1	0	N																
H10	Energy saving operation	0: Inactive 1: Active	1	0	Y																
H11	Decel mode	0: Normal 1: Coast-to-stop	1	0	Y																
H12	Instantaneous overcurrent limiting	0: Inactive 1: Active	1	1	N																
H13	Auto-restart (Restart time)	0.1 to 5.0 seconds	0.1s	0.1	N																
H14	Frequency fall rate	0.00 to 100.0 Hz/second	0.01Hz/s	10.00	Y																
H20	PID control (Mode select)	0: Inactive 1: Forward operation 2: Reverse operation	1	0	N																
H21	(Feedback signal)	0: Terminal 12 (0 to +10 VDC) input 1: Terminal C1 (4 to 20 mA) input 2: Terminal 12 (+10 to 0 VDC) input 3: Terminal C1 (20 to 4 mA) input	1	1	N																
H22	P (Gain)	0.01 to 10.00 times (1 to 1000%)	0.01 time	0.10	Y																
H23	I (Integral time)	0.0: Inactive 0.1 to 3600 seconds	0.1s	0.0	Y																
H24	D (Differential time)	0.00: Inactive 0.01 to 10.0 seconds	0.01s	0.00	Y																
H25	(Feedback filter)	0.0 to 60.0 seconds	0.1s	0.5	Y																
H26	PTC thermistor (Mode select)	0: Inactive 1: Active		0	Y																
H27	(Level)	0.00--5.00V	0.01V	1.60	Y																
H28	Droop operation	-9.9 --0.0 Hz	0.1 Hz	0.0	Y																
H30	Serial link (Function select)	<table border="1"> <thead> <tr> <th>Monitor</th> <th>Frequency setting</th> <th>Operation command</th> </tr> </thead> <tbody> <tr> <td>0: X</td> <td>—</td> <td>—</td> </tr> <tr> <td>1: X</td> <td>X</td> <td>—</td> </tr> <tr> <td>2: X</td> <td>—</td> <td>X</td> </tr> <tr> <td>3: X</td> <td>X</td> <td>X</td> </tr> </tbody> </table>	Monitor	Frequency setting	Operation command	0: X	—	—	1: X	X	—	2: X	—	X	3: X	X	X	1	0	Y	
Monitor	Frequency setting	Operation command																			
0: X	—	—																			
1: X	X	—																			
2: X	—	X																			
3: X	X	X																			

Y: The data can be changed with the UP or DOWN arrow key during operation. However, press the FUNC/DATA key to store the new data.

Y*: Press the UP or DOWN arrow key to change the data. The new data takes effect after the FUNC/DATA key is pressed to store the data.

N: The data can be changed only while the motor is stopped.

Function Code	Name	Setting Range	Min. Unit	Factory Setting	Change During Operation	User Setting
H: High performance functions (continued)						
H31	Modbus-RTU (Address)	0: Broadcast 1 to 247: Query	1	1	N	
H32	(Mode select on no response error)	0: Immediate Er8 1: Er8 after interval set by 2: Retry 3: Continuation of operation	1	0	Y	
H33	(Timer)	0.0 to 60.0 seconds	0.1s	2.0	Y	
H34	(Baud rate)	0: 19200 [bits/second] 1: 9600 2: 4800 3: 2400	1	1	Y	
H35	(Data length)	0: 8 bit (Fixed)	1	0	—	
H36	(Parity check)	0: None 1: Even parity 2: Odd parity	1	0	Y	
H37	(Stop bits)	0: 2 bits 1: 1 bit	1	0	Y	
H38	(No response error detection time)	0: Not detected 1: 1 to 60 seconds	1s	0	Y	
H39	(Response interval)	0.00 to 1.00 second	0.01s	0.01	Y	
H40	Maximum temperature of heat sink	Monitor only	degree C	—	—	
H41	Maximum effective current	Monitor only	A	—	—	
H42	Main circuit capacitor life	Monitor only	%	—	—	
H43	Cooling fan operation time	Monitor only	10h	—	—	
H44	Drive ROM version	Monitor only	—	—	—	
H45	Keypad ROM version	Monitor only	—	—	—	
H46	Option ROM version	Monitor only	—	—	—	

A: Alternative motor parameters

A01	Maximum frequency 2	50 to 400 Hz	1 Hz	60	N	
A02	Base frequency 2	25 to 400 Hz	1 Hz	60	N	
A03	Rated voltage 2 (at base frequency 2)	0V, 80 to 240V (230V class) 0V, 160 to 480V (460V class)	1V	230 460	N	
A04	Maximum voltage 2 (at maximum frequency 2)	80 to 240 V (230V class) 160 to 480V (460V class)	1V	230 460	N	
A05	Torque boost 2	0, 1, 2, 3 to 31	1	13	Y	
A06	Electronic thermal overload relay (Select)	0: Inactive 1: Active (for general purpose motors) 2: Active (for forced air extended operating range motors)	1	1	Y*	
A07	(Level)	20 to 135% of the rated motor current	0.01A	rated motor current	Y	
A08	(Thermal time constant)	0.5 to 10 min.	0.1 min	5.0	Y	
A09	Torque vector control 2	0: Inactive 1: Active	1	0	N	
A10	Number of motor 2 poles	2 to 14	2	4	N	
A11	Motor 2 (Capacity)	0.01 to 7-1/2 HP (5 HP or smaller) 0.01 to 15 HP (7-1/2 / 10 HP)	0.01 HP	Nominal applied motor HP	N	
A12	(Rated current)	0.00 to 99.9A	0.01A	standard rating	N	
A13	(Tuning)	0: Inactive 1: Active (%R1, %X) 2: Active (%R1, %X, lo)	1	0	N	
A14	(Online tuning)	0: Inactive 1: Active	1	0	N	
A15	(No-load current)	0.00 to 99.9A	0.01A	standard rating	N	
A16	(%R1 setting)	0.00 to 50.00%	0.01%	standard rating	Y	
A17	(%X setting)	0.00 to 50.00%	0.01%	standard rating	Y	
A18	(Slip compensation control 2)	0.00 to 15.00 Hz	0.01 Hz	0.00	Y	
A19	(Slip compensation response time 2)	0.01 to 10.00 seconds	0.01s	0.50	Y	

Y: The data can be changed with the UP or DOWN arrow key during operation. However, press the FUNC/DATA key to store the new data.

Y*: Press the UP or DOWN arrow key to change the data. The new data takes effect after the FUNC/DATA key is pressed to store the data.

N: The data can be changed only while the motor is stopped.

Notes

Parameter descriptions and additional information can be found in the ACE 20 Series Technical Manual (ACE20TM), available at the Boston Gear Web Site (www.BostonGear.com) or by phoning Boston Gear at 888-999-9860.

6. Protective Operation

6-1 List of Protective Operations

When an error occurs to the drive, a protective function activates to trip the drive immediately, displaying the name of the alarm on the LED display and allowing the motor to coast-to-stop.

Table 6-1-1 List of alarm display and protective operations

Name of Alarm	Display	Description of Operation
Overcurrent protection	OC1	During acceleration
	OC2	During deceleration
	OC3	During constant speed operation
		The protective function activates when an overcurrent flowing in the motor, or a short circuit or ground fault in the output circuit, causes the instantaneous drive output current to exceed the overcurrent detection level.
Overvoltage protection	OU1	During acceleration
	OU2	During deceleration
	OU3	During constant speed operation
		The protective function activates when the regenerative power from the motor increases to cause the DC link voltage of the main circuit to exceed the overvoltage detection level (400 VDC for 230V input, 800 VDC for 460V input). When an excessive voltage is added to the source voltage, the drive trips due to the overvoltage, but drive protection against the overvoltage is impossible.
Undervoltage protection	LU	The protective function activates when the source voltage drops to cause the DC link voltage in the main circuit to become lower than the undervoltage detection level (200 VDC for 230V input, 400 VDC for 460V input). If F14 "Restart after momentary power failure" has been selected, no alarm display is given. If the voltage drops below the control power maintenance level, no alarm is displayed.
Input phase loss protection	Lin	If Input power L1/R, L2/S, L3/T has any phase of the 3 phase power "OPEN" or if there is a significant disparity between the phases, the rectifying diodes or smoothing capacitors may be damaged. An alarm is displayed and the protective function activates.
Heat sink overheat	OH1	The protective function activates when the temperature of the drive heat sink is high.
External alarm input	OH2	The protective function activates by a contact signal from an alarm contact of an external device such as the braking unit, braking resistor, or external thermal overload relay connected to the control circuit terminal (THR). Or an overheat protective function is activated by the PTC thermistor.
Braking resistor overheat	dbH	If the electronic thermal overload relay (for the braking resistor) has been selected by function Code F13, the protective function activates upon a high operation frequency of the braking resistor to prevent the resistor from being burned due to the temperature rise.
Motor 1 overload	OL1	If electronic thermal overload relay 1 has been selected by function Code F10, the protective function activates when motor current exceeds the set operation level.
Motor 2 overload	OL2	If motor 2 is being driven, and electronic thermal overload relay 2 has been selected by function Code A06, the protective function activates when the current in motor 2 exceeds the set operation level.
Drive overload	OLU	The protective function activates when an output current exceeds the overload current rating to protect the semiconductor elements in the main circuit of the drive from high temperatures.
Memory error	Er1	The protective function activates by a data writing error or other errors in the memory.
Keypad panel communication error	Er2	The protective function activates when a data transmission error or transmission stoppage is detected between the keypad panel and the control section in the keypad panel operation mode.
CPU error	Er3	The protective function activates by electric noise or other errors developed in the CPU.
Option error	Er4	Error during operation of an option
	Er5	
Operating error	Er6	Detects operating procedure error during startup. FWD or REV connected to terminal CM when main power is applied to the drive (F02 setting 3 or 4). Stop key on the keypad is pressed in terminal operation (F02 setting 1 or 3).
Output phase loss	Er7	The protective function activates during auto tuning when there is a broken wire or no connection in the drive output circuit.
RS485 communication error	Er8	The protective function activates when a communication error occurs during communication through RS485.

6-2 Alarm Reset

If the drive trips, remove the cause, and then press the PRG/RESET key on the keypad panel or input a reset command from the RST control terminal to reset the tripped state. Because the reset command activates by an edge, supply the command in an OFF - ON - OFF sequence as shown in Fig. 6-2-1.

When resetting the tripped state, deactivate the operation command. If the operation command is left turned on, the motor will start immediately after the error is reset.

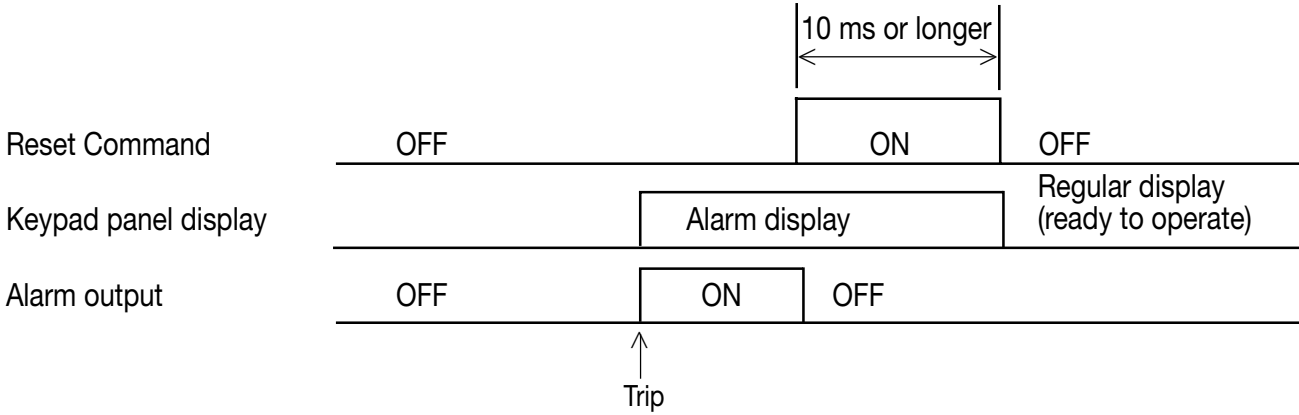

Figure 6-2-1

DANGER

If an alarm reset is made with the operation signal turned on, a sudden start will occur. Check that the operation signal is turned off in advance. **Otherwise, an accident could occur.**

7. Troubleshooting

7.1 Protective function activation

(1) Overcurrent

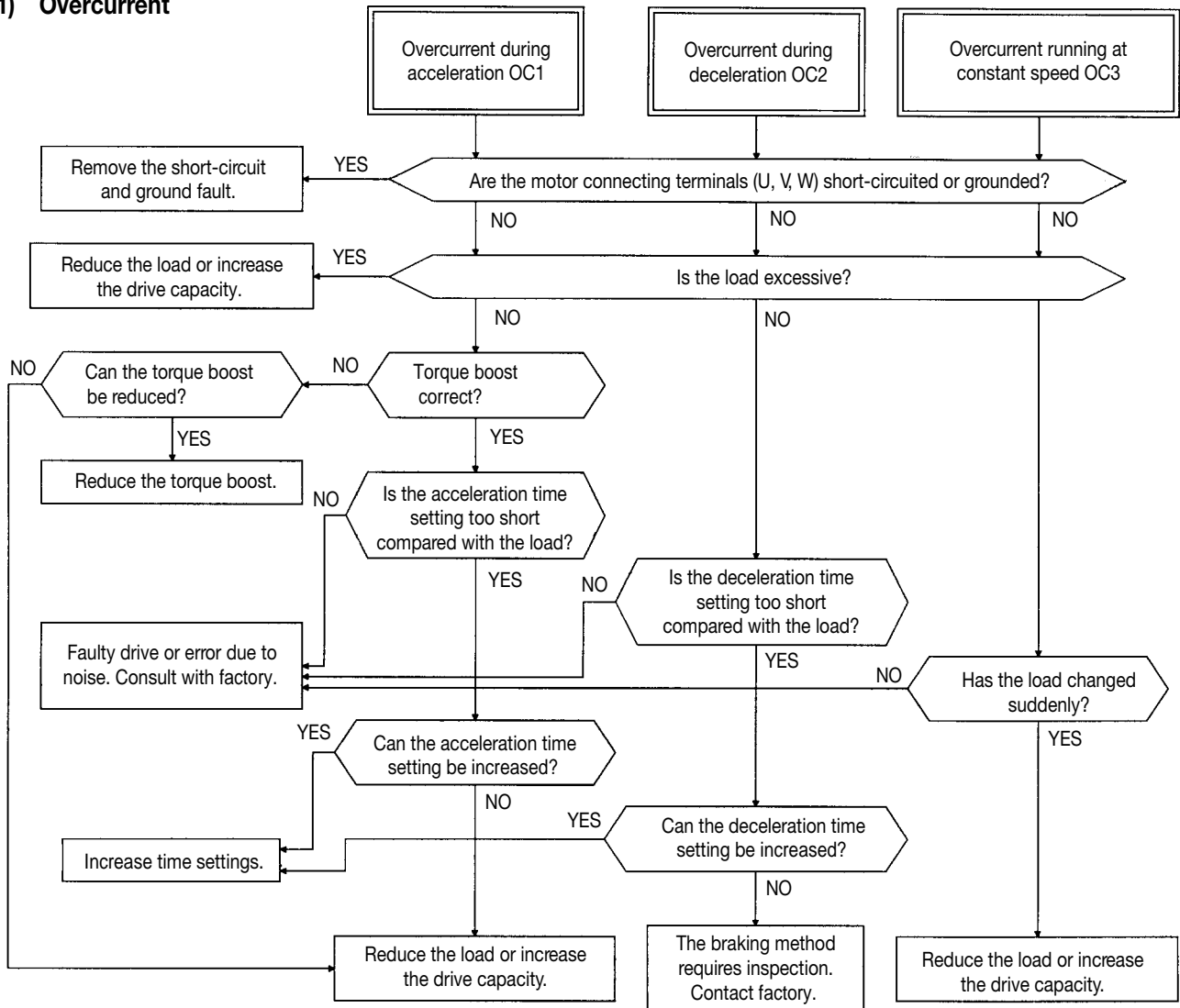

(2) Overvoltage

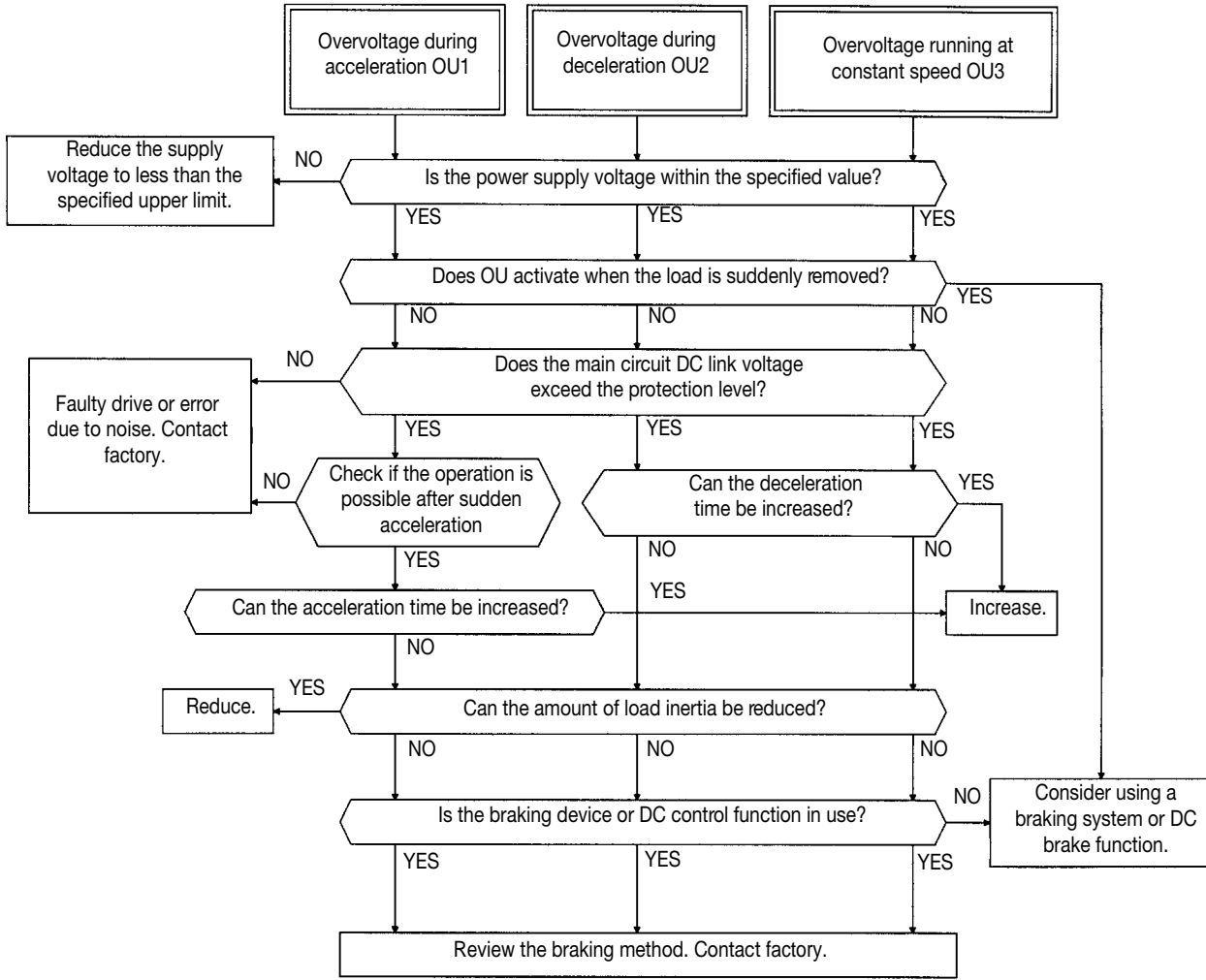

(3) Undervoltage

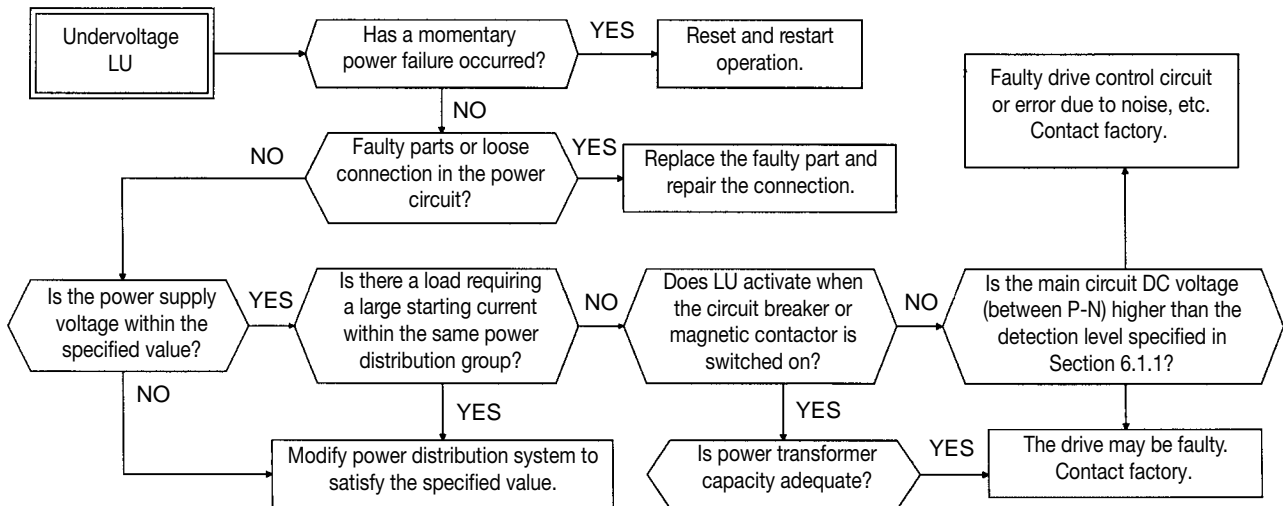

(4) Overheating of heat sink

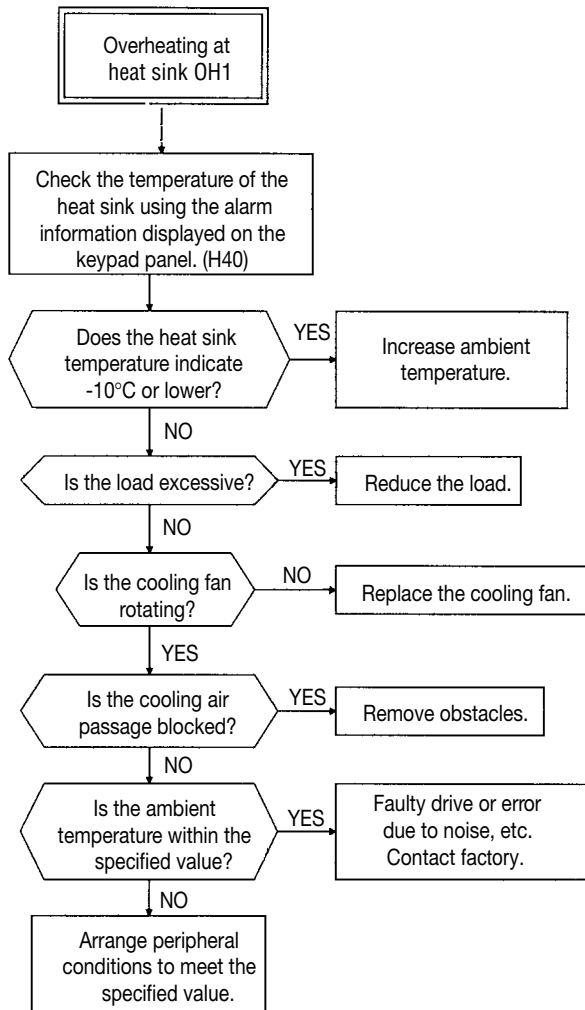

(5) Drive overload and motor overload

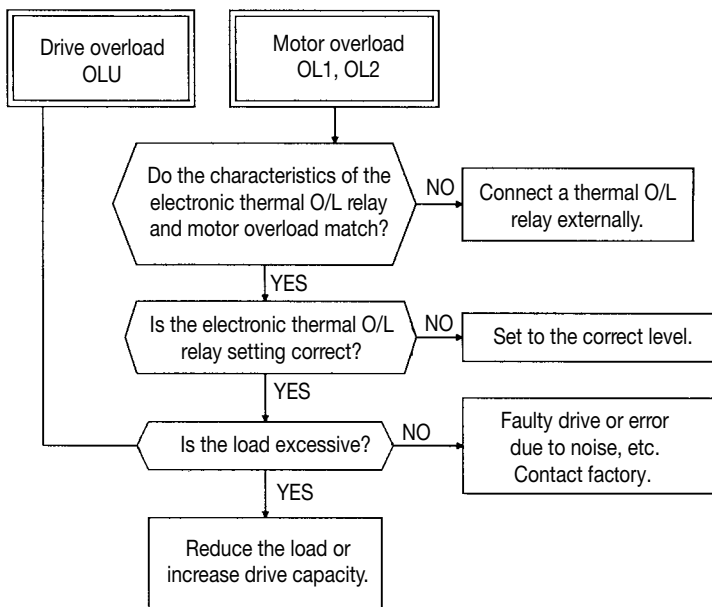

(6) External thermal relay tripped

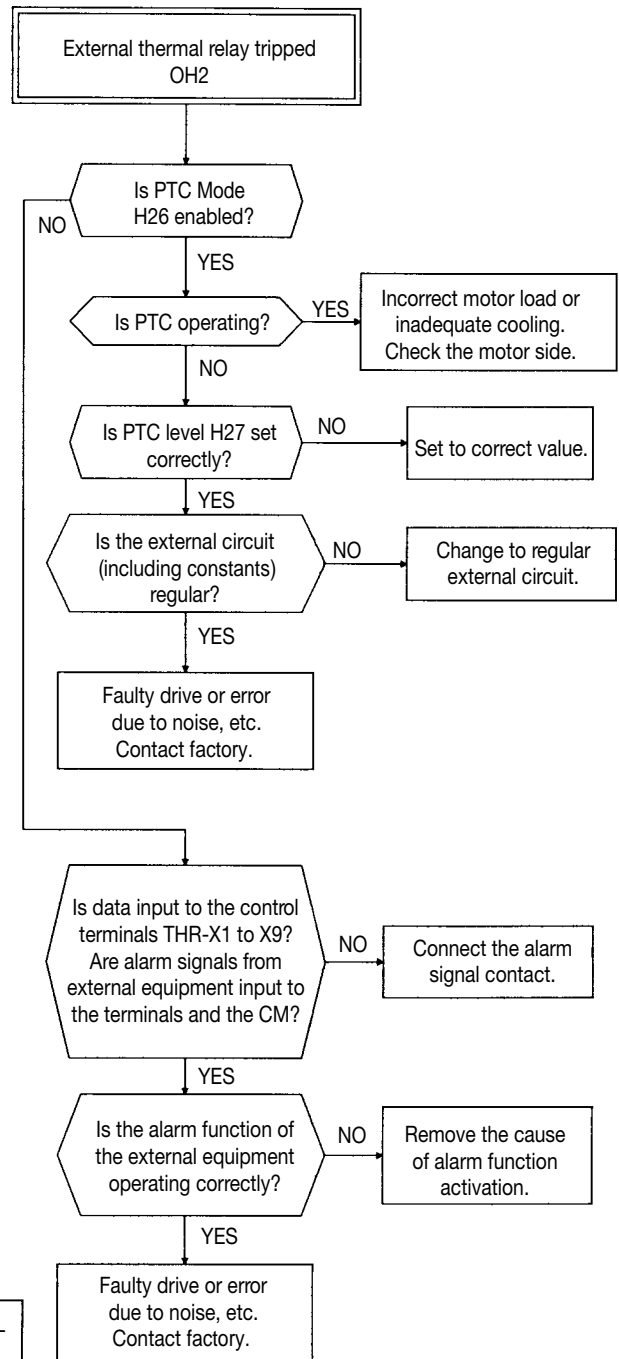

**(7) Memory error Er1,
Keypad panel communication error Er2,
CPU error Er3**

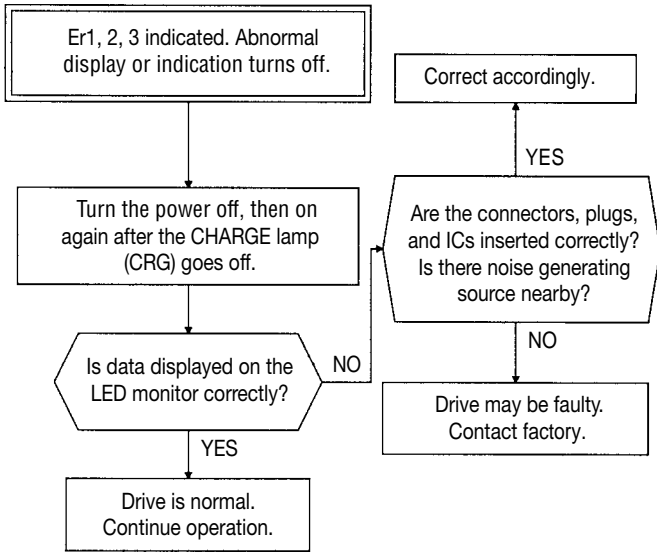

(8) Output wiring error

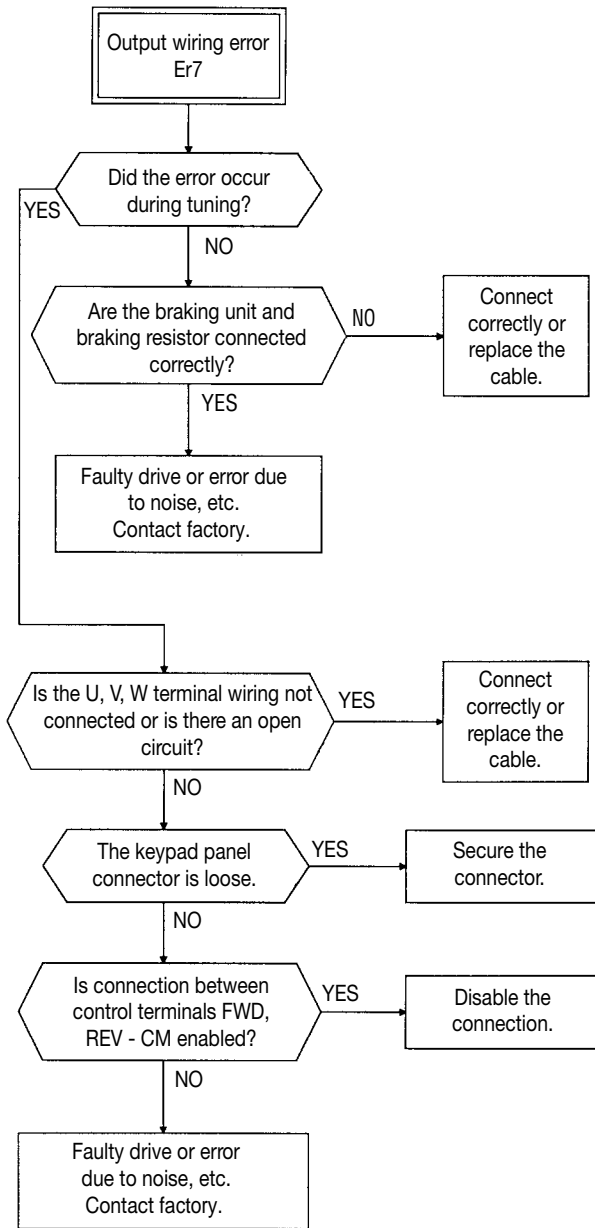

(9) Input Phase Loss

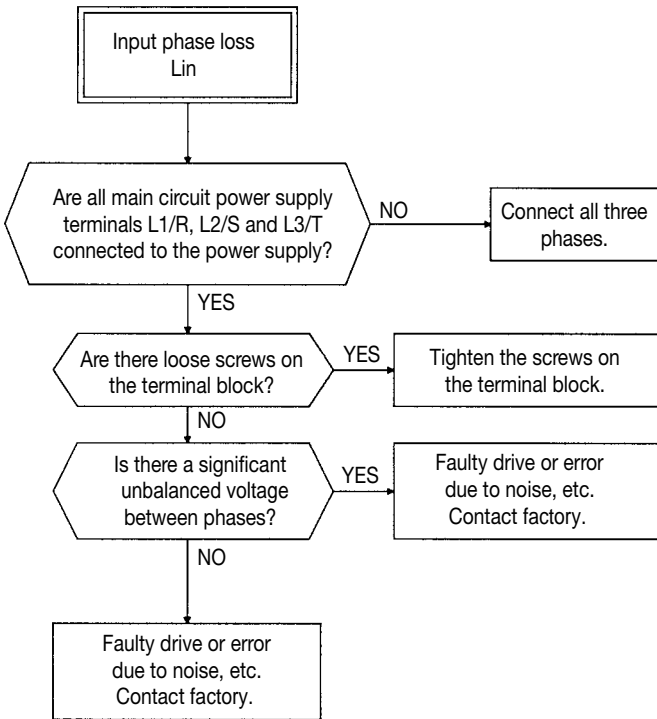

7.2 Abnormal motor rotation

(1) If motor does not rotate

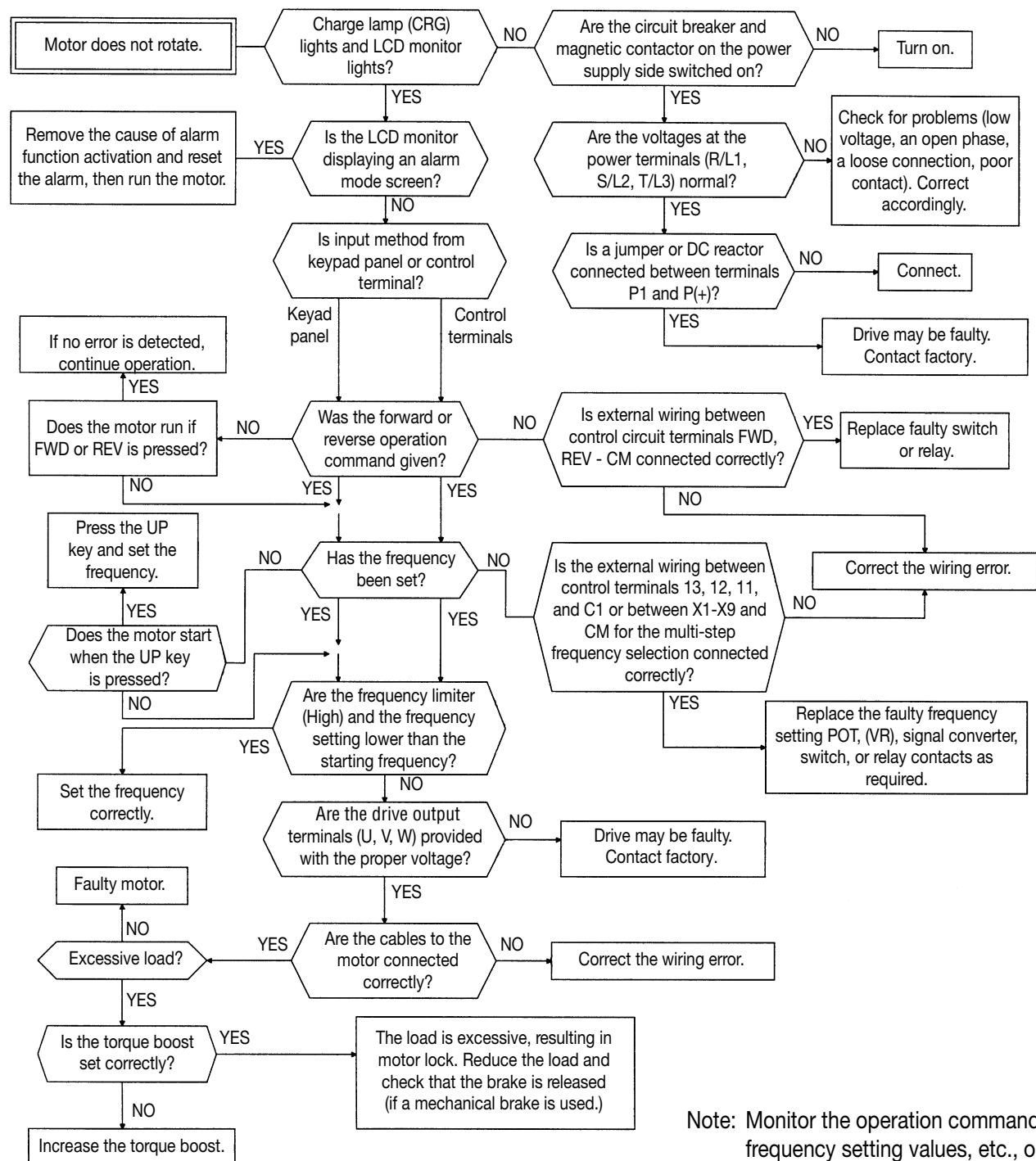

Note: Monitor the operation command or frequency setting values, etc., on the LED or LCD monitor after selecting the respective functions.

The motor will not rotate when the following commands are issued.

- An operation command is issued while the coast-to-stop or DC braking command is being input.
- Both FWD and REV operation commands are being inputted.

(2) If the motor rotates but the speed does not change

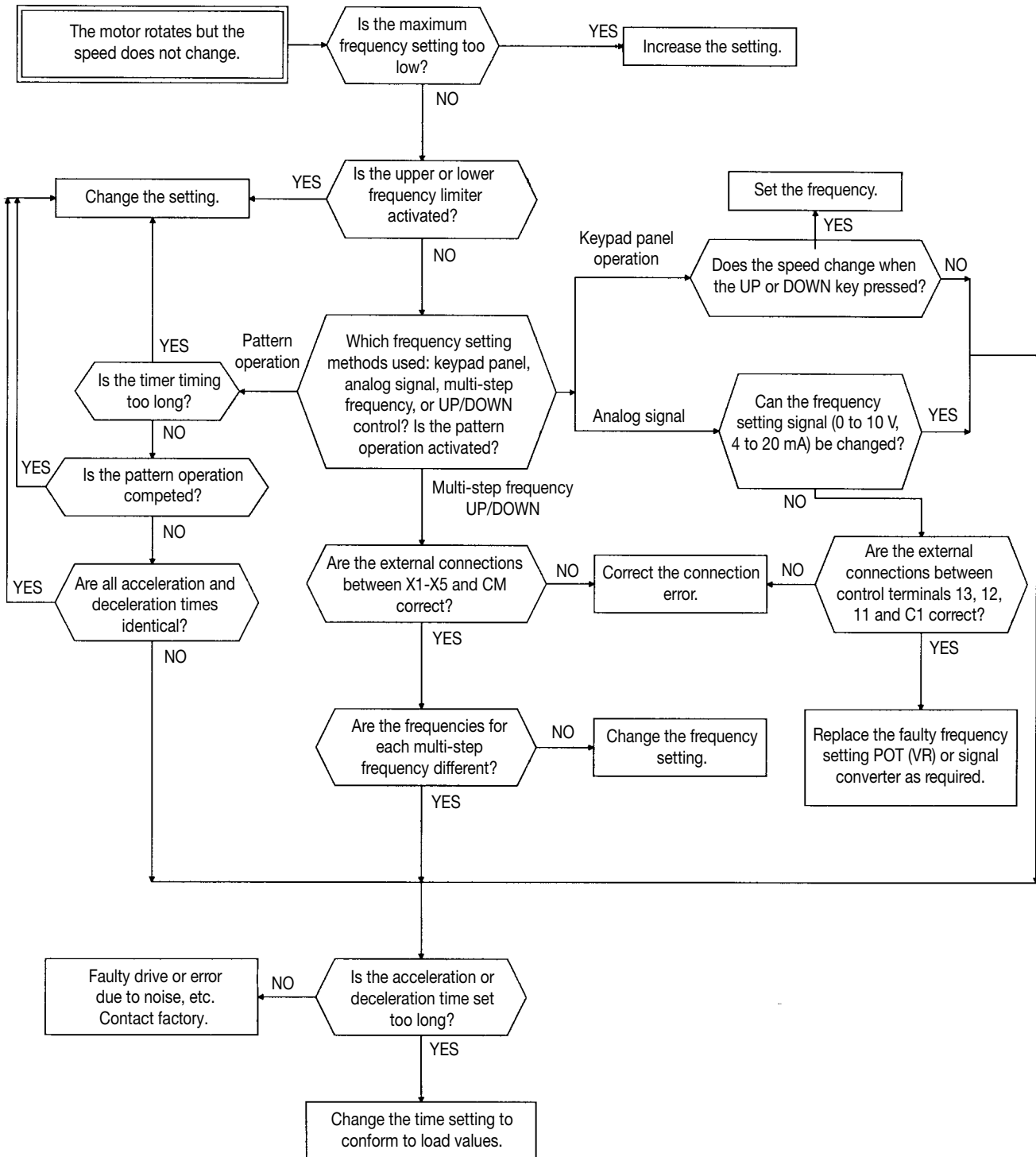

In the following cases, changing the motor speed will also be restricted.

- Signals are input from control terminals 12 and C1 when “F01 Frequency command 1” and “C30 Frequency command 2” are set to 3, and there is no significant change in the added value.
- The load is excessive, and the torque limiting and current limiting functions are activated.

(3) Motor stalls during acceleration

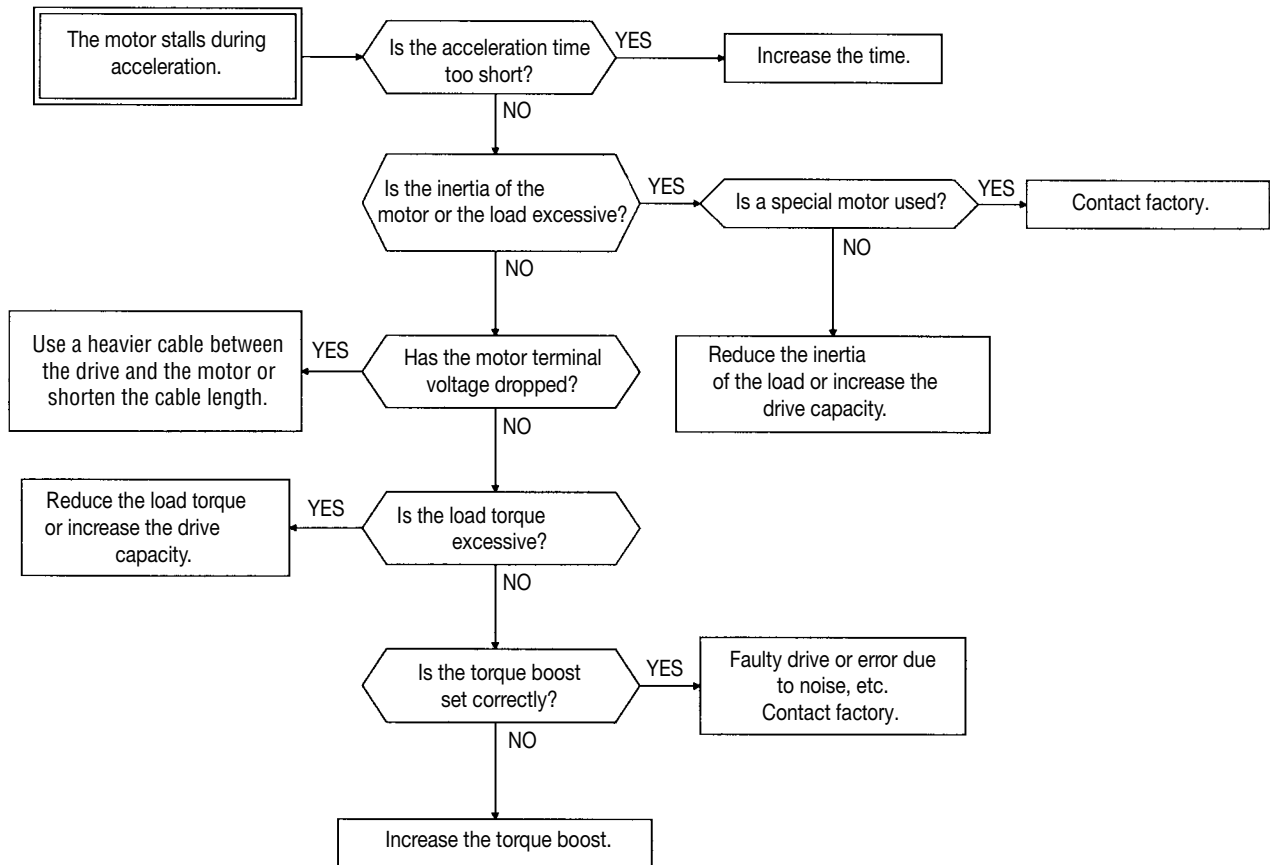

(4) Excessive heat generation from motor

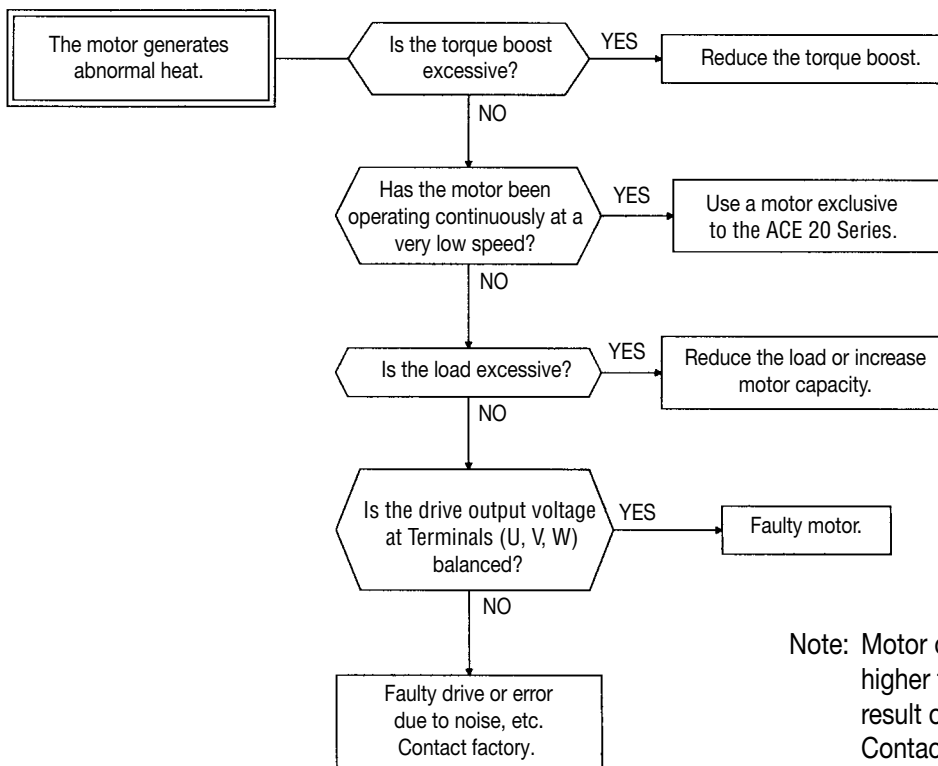

Note: Motor overheating following a higher frequency setting is likely the result of the current waveform. Contact factory.

Notes:

8. Warranty Parts and Service

The purpose of this section is to provide specific instructions to the user of the standard drive referenced in this book regarding warranty administration and how to obtain assistance on both in-warranty and out-of-warranty equipment.

For all warranty procedures, refer to section 10 of the technical manual (ACE20TM) to identify the part or assembly.

If assistance is required to determine warranty status, identify defective parts, or obtain the name of your local distributor, call:

Boston Gear

14 Hayward Street

Quincy, MA 02191 USA

Phone: + 1-800-816-5608 (United States)

Fax: + 1-617-479-6238

("+" indicates the international access code required when calling from outside of the USA.)

WARRANTY COVERAGE

The warranty covers all major parts of the drive such as the main printed circuit boards, transistor modules, etc. The warranty does not cover replacement of fuses or of the entire drive.

"Warranty period is 24 months after shipment from the Company."

However, the guarantee will not apply in the following cases, even if the guarantee term has not expired:

1. Damage was caused by incorrect use or inappropriate repair or modification.
2. The product was used in an environment outside the standard specified range.
3. Damage was caused by dropping the product after purchase or damage occurred during transportation.
4. Damage was caused by an earthquake, fire, flooding, lightning, abnormal voltage, or other natural calamities and secondary disasters.

Before calling the number at the left to determine warranty status, the drive serial number will be required. This is located on the drive nameplate. If the drive is still under warranty, further information will be required per the "In-Warranty Failure Checklist" shown on page 8-2 of this instruction manual.

OUT-OF WARRANTY PROCEDURES

When the defective part has been identified, contact your local authorized Boston Gear distributor to order replacement parts.

MOTORS

For specific instructions on your motor, call the distributor from which it was purchased and be prepared to furnish complete nameplate data.

IN-WARRANTY FAILURE CHECKLIST

To assist with warranty troubleshooting, the following information is required. This data is needed to evaluate the cause in an effort to eliminate any further failures.

Model No.: _____

Serial No.: _____

Start-Up Date: _____

Failure Date: _____

Status When Failure Occurred (check one):

Power-Up _____ Running _____ Accel _____ Decel _____

Explanation of Failure _____

Application Information (check Yes or No)

Input Transformer: Yes _____ No _____

If Yes: KVA _____

L1 Volts _____ L2 Volts _____ L3 Volts _____

Power Factor Correction Capacitors: Yes _____ No _____

If Yes: Microfarrad _____

Other Equipment on Same Power Yes _____ No _____

If Yes, what?

Line Reactor on Input Yes _____ No _____

Input Starter Yes _____ No _____

Output Starter Yes _____ No _____

Motor Overloads Yes _____ No _____

Control Terminals Used (circle if used)

30A	30B	Y1	C1	FM	X1	X2	X3	X4	X5	PLC
30C	Y2	CME	11	12	13	CM	FWD	REV	CM	P24

Function Codes Different From Factory Settings

Function Code	Setting

Function Code	Setting

Failure Message (see Section 4)

Latest Fault _____ Previous Faults: No Message _____

Hz _____ 1. _____

A _____ 2. _____

V _____ 3. _____

After all of the Checklist information is acquired, contact the following number for assistance: 800-816-5608.

9. Specifications

9.1 Standard Specifications

(1) Three-phase 230V input

Item		Detail Specifications								
Drive HP		1/8	1/4	1/2	1	2	3	5	7.5	10
Nominal applicable motor ¹ [HP]		1/8	1/4	1/2	1	2	3	5	7.5	10
Output ratings	Rated capacity ² [kVA]	0.3	0.6	1.2	2.0	3.2	4.4	6.8	9.9	13.1
	Rated Voltage ³ [V] ¹³	Three-phase 200V / 50 Hz, 200V, 220V, 230V / 60 Hz (with AVR ¹² function)								
	Rated current [A] ⁴	0.7	1.4	2.5	4.0	7.0	10.0	16.5	23.5	31.0
		(0.8)	(1.5)	(3)	(5)	(8)	(11)	(17)	(25)	(33)
	Overload current rating	150% of rated output current for 1 minute 200% of rated output current for 0.5 second								
Rated frequency [Hz]		50, 60 Hz								
Input ratings	Number of phases, voltage, frequency	Three-phase 200 to 230 V / 50 to 60 Hz ¹¹								
	Voltage and frequency fluctuation	Voltage:		+10 to -15%, Voltage unbalance 2% or less ¹⁰						
		Frequency:		+5 to -5%						
	Resistance to instantaneous voltage drop ⁵	Operation continues at 165V or higher voltage. When the input voltage drops below 165V, operation continues for 15 ms.								
	Rated input current [A] (With DCR)	0.59	0.94	1.6	3.1	5.7	8.3	14	19.7	26.9
Rated input current [A] (Without DCR) ⁹	1.1	1.8	3.4	6.4	11.1	16.1	25.5	40.8	52.6	
Power requirement ⁶ [kVA]	0.3	0.4	0.6	1.1	2.0	2.9	4.9	6.9	9.4	
Braking	Braking torque ⁷ [%]	100		70			40		20	
	Braking torque ⁸ [%]	150								
	DC braking	Starting frequency: 0.2 to 60.0 Hz, braking current (0 to 100% in 1% increment), braking time (0.0 to 30.0 seconds)								
Enclosure (IEC60529)		NEMA 1 standard, IP20 chassis optional								
Cooling method		Self-cooling				Fan cooled				
Weight (lbs)		2.4	2.4	2.8	3.1	5.1	5.1	7.9	17.7	17.7

*1 The applicable standard motor refers to a 4-pole standard motor.

*2 The rated capacity is based on a 230V input.

*3 Voltages greater than the source voltage cannot be supplied.

*4 Amperage values in parentheses () are applicable to operation with 3 kHz or lower carrier frequency (F26 = 3 or less). These values also apply when the ambient temperature is below 40°C (104°F).

*5 Tests are performed under standard load conditions (load equivalent of 85% with an applicable standard motor) defined by NEMA.

*6 Data is with a DC reactor (DCR) installed.

*7 Indicates the average braking torque for decelerating and stopping one motor from 60 Hz. Varies according to the efficiency of the motor.

*8 Indicates the value with an external braking resistor (optional).

*9 Calculated on the assumption that the drive is connected to a 500 kVA power supply.

*10 Refer to IEC61800-3 5.2.3.

*11 Safe separation for control interface of the drive is provided when the drive is installed in overvoltage category II (CE Standard). Basic insulation for control interface of the drive is provided when the drive is installed in overvoltage category III (CE Standard).

*12 Automatic voltage regulator. (Function Code F05.)

*13 For single-phase operation, de-rate the drive by 1/2, (e.g., if a 10HP drive is to operate from a single-phase 230V line, use the 5HP column for ratings).

(2) Three-phase 460V input

Item		Detail Specifications						
Drive HP		1/2	1	2	3	5	7.5	10
Nominal applicable motor ¹ [HP]		1/2	1	2	3	5	7.5	10
Output ratings	Rated capacity ² [kVA]	1.2	2.0	2.9	4.4	7.2	10.3	14.3
	Rated Voltage ³ [V]	Three-phase 380,400, 415V / 50 Hz; 380, 400, 440 / 60 Hz (with AVR ¹² function)						
	Rated current ⁴ [A]	1.4	2.1	3.7	5.3	8.7	12	16
		(1.5)	(2.5)	(3.7)	(5.5)	(9)	(13)	(18)
	Overload current rating	150% of rated output current for 1 minute						
		200% of rated output current for 0.5 second						
Rated frequency [Hz]	50, 60 Hz							
Input ratings	Number of phases, voltage, frequency	Three-phase 380 to 480 V / 50 to 60 Hz ¹¹						
	Voltage and frequency fluctuation	Voltage:	+10 to -15% Voltage unbalance 2% or less ¹⁰					
		Frequency:	+5 to -5%					
	Resistance to instantaneous voltage drop ⁵	Operation continues at 300V or higher voltage. When the input voltage drops below 300V, operation continues for 15 ms.						
	Rated input current [A] (With DCR)	0.82	1.5	2.9	4.2	7.1	10	13.5
		(Without DCR) ⁹	1.8	3.5	6.2	9.2	14.9	21.5
Power requirement ⁶ [kVA]	0.3	0.4	0.6	1.1	2.0	2.9	4.9	
Braking	Braking torque ⁷ [%]	70			40		20	
	Braking torque ⁸ [%]	150						
	DC braking	Starting frequency: 0.2 to 60.0 Hz, braking current (0 to 100% in 1% increment), braking time (0.0 to 30.0 seconds)						
Protective structure (IEC60529)	NEMA 1 standard, IP20 chassis optional							
Cooling method	Self-cooling			Fan cooled				
Weight (lbs)	4.3	4.7	5.1	5.5	7.5	17.7	17.7	

*1 The applicable standard motor refers to a 4-pole standard motor.

*2 The rated capacity indicates a 460V input rating.

*3 Voltages greater than the source voltage cannot be output.

*4 Amperage values in parentheses () are applicable to operation with 3 kHz or lower carrier frequencies (F26 = 3 or less). These values also apply when the ambient temperature is below 40°C.

*5 Tests are performed under standard load conditions (load equivalent of 85% with an applicable standard motor) defined by NEMA.

*6 Data is with DC reactor (DCR) installed.

*7 Indicates the average braking torque for decelerating and stopping one motor from 60 Hz. (Varies according to the efficiency of the motor.)

*8 Indicates the value with an external braking resistor (option).

*9 Calculated on assumption that the drive is connected to a 500 kVA power supply.

*10 Refer to IEC61800-3 5.2.3.

*11 Safe separation for control interface of the drive is provided when the drive is installed in overvoltage category II (CE Standard). Basic insulation for control interface of the drive is provided when the drive is installed in overvoltage category III (CE Standard).

*12 Automatic voltage regulator. (FO5)

9.2 Common Specifications

Item		Detail Specifications
Output frequency	Maximum frequency	50 to 400 Hz
	Base frequency	25 to 400 Hz
	Starting frequency	0.1 to 60.0 Hz, Holding time : 0.0 to 10.0 seconds
	Carrier frequency	0.75 to 15 kHz (The carrier frequency may automatically drop to 0.75 kHz to protect the drive.)
	Accuracy	Analog reference: Within $\pm 0.2\%$ (25° , $\pm 10^\circ\text{C}$) Digital reference: Within 0.01% (-10° to $+50^\circ\text{C}$)
Reference resolution	Analog reference: 1/3000 of maximum output frequency Keypad panel reference: 0.01 Hz (99.99 Hz or lower), 0.1 Hz (100.0 to 400.0 Hz) LAN reference : 1/20000 of maximum frequency (0.003 Hz at 60 Hz, 0.006 Hz at 120 Hz, 0.02 Hz at 400 Hz), or 0.01 Hz (Fixed)	
Control	Voltage/freq. Characteristics	Adjustable at base and maximum frequency, with AVR control : 80 to 240V (200V rating), 160 to 480V (400V rating)
	Torque boost	Automatic: Automatic torque boost can be selected with a function code setting. Manual: Setting by codes 1 to 31 (Boost for variable torque available)
	Starting torque	200% or above (with dynamic torque vector turned on, during 0.5 Hz operation)
	DC braking	Braking time (0.0 to 30.0 seconds), braking current (0 to 100%), braking starting frequency (0.0 to 60.0 Hz)
	Control method	Sinusoidal PWM (Dynamic torque vector control) with "current vibration suppression function" and "dead time compensation function"
Operation method	Keypad operation: starting and stopping with RUN and STOP keys. (Keypad panel) Digital input signal: forward (reverse) operation, stop command (3-wire operation possible), coast-to-stop command, external alarm, error reset, etc. Link operation: RS485 Modbus RTU (Standard) Profibus-DP, Interbus-S, DeviceNet, Modbus Plus, CAN open (Options)	

*1 Automatic voltage regulator (FO5).

Item	Specifications
Frequency reference (UP/DOWN control) (Multistep frequency) (Link operation)	Keypad operation: UP arrow key and DOWN arrow key. Potentiometer (external potentiometer: 5k ohms, 1/2 W) 0 to ± 5 VDC. 0 to ± 10 VDC. 4 to 20 mA DC. 0 to +10 VDC / 0 to 100% speed can be switched externally to +10 to 0 VDC / 0 to 100% speed. 4 to 20 mA DC/0 to 100% speed can be switched externally to 20 to 4 mA DC/0 to 100% speed. An external signal can be used to control the UP or DOWN command. Up to 16 different frequencies can be selected by digital input signals. Link operation: RS485 (Standard) Profibus-DP, Interbus-S, DeviceNet, Modbus Plus, CAN open (Options)
Acceleration / deceleration time (Mode select)	Adjustable within 0.01 to 3600 second range. (2 sets of time parameters can be set internally for each acceleration and deceleration.) Linear, S-curve (weak, strong), Non-linear available.
Frequency limiter	The high and low frequency limits can be set in Hz.
Bias frequency	Can be set within -400 to 400 Hz range.
Gain (frequency setting)	Can be set within a 0 to 200% range.
Jump frequency control	Three jump frequencies and jump width (0 to 30 Hz) can be set.
Rotating motor pickup (Flying start)	Operation without shock is possible.
Auto-restart after momentary power failure	The motor speed can be detected after power recovery so that the motor is started at that speed.
Slip compensation control	The load can be detected for control of the output frequency. The compensation value can be set in a 0.00 to +15.00 Hz range of the rated frequency.
Droop operation	The load can be detected for control of the frequency. The compensation value can be set within a 9.9 to 0.0 Hz range of the rated frequency. (Speed droop characteristics)
Torque limiter	When the load torque in the driving or braking mode exceeds the setting, the output frequency is adjusted to control the load torque to an almost constant level. The limiting torque can be set between 20 to 200% and the driving and braking torque values can be set independently. The second torque limits can also be set.

	Item	Specifications
Control	PID control This function can control flow rate, pressure, etc. with analog feedback signal. The reference and feedback values are displayed in %. Reference signal Keypad operation UP key and DOWN key. : 0.0 to 100% Voltage input (Terminal 12) : 0 to 10 VDC Current input (Terminal C1) : 4 to 20 mA DC Multistep frequency setting : Setting freq./max. freq. x 100% RS485 : Setting freq./max. freq. x 100% Feedback signal Terminal 12 (0 to +10Vdc or +10 to 0Vdc) Terminal C1(4 to 20mAdc or 20 to 4mAdc)	
	Second motor's setting The V/f pattern of the second motor can be selected with an external signal. The motor constants of the second motor can be set with an external signal. The electronic thermal overload relay of the second motor can be internally set for selection with an external signal.	
	Energy saving operation Weak magnetic flux can be set for light loads which allows operation with an increased motor efficiency.	
Display	During operation/stop The keypad panel can be extended. (Optional 5 meter (16 foot) extension cable is available.) 7-segment LED display items <ul style="list-style-type: none"> • Set frequency • Output current • Output voltage • Output frequency • Motor RPM • Line speed • PID setting/feedback values (A soft filter is provided to attenuate the fluctuation in the displayed value.) A charge lamp indicates the power supply is energized.	
	When setting When tripped The function code and data code are displayed. [The cause of trip is displayed.] <ul style="list-style-type: none"> • OC1 (overcurrent: during acceleration) • OC2 (overcurrent: during deceleration) • OC3 (overcurrent: during constant speed operation) • OU1 (overvoltage: during acceleration) • OU2 (overvoltage: during deceleration) • OU3 (overvoltage: during constant speed operation) • LU (undervoltage) • Lin (input phase loss) • dbH (external braking resistor overheated (thermal overload relay)) • OH1 (overheat: heat sink) • OH2 (overheat: external thermal overload relay) • OL1 (overload: motor 1) • OL2 (overload: motor 2) • OLU (overload: drive) • Er1 (memory error) • Er2 (keypad panel communication error) • Er3 (CPU error) • Er4 (option error) • Er5 (option error) • Er6 (operating error) • Er7 (output wiring error) (impedance imbalance) • Er8 (RS485 communication error) 	
	During operation, when tripped The last four records of trip history are stored and displayed.	

Overload protection	Drive electronic thermal overload relay								
Overvoltage protection	Detects high voltage in the DC link circuit (approx. 400 VDC for 230V class, approx. 800 VDC for 460V class).								
Overcurrent protection	The drive is protected against an overcurrent on the output.								
Surge protection	The drive is protected against a surge voltage between the power cable of the main line and ground.								
Undervoltage protection	Detects voltage level (approx. 200 VDC for 230V class, approx. 400 VDC for 460V class) in the DC link circuit.								
Overheat protection	The drive is protected against failure and overload of the cooling fan.								
Short-circuit protection	The drive is protected against an overcurrent caused by a short-circuit on the output.								
Ground fault protection	The drive is protected against an overcurrent caused by ground fault in the output wiring * Detection when starting								
Motor protection	Electronic thermal overload relays protect general purpose motors and forced air motors. The thermal time constant can be adjusted from 0.5 to 10.0 minutes. Second electronic thermal overload relay can be provided. (Switched with external signal)								
Braking resistor protection	Upon overheating of the braking resistor (external unit), the motor stops.								
Stall prevention (simple torque limit)	<ul style="list-style-type: none"> • When the output current exceeds the setting during acceleration, the speed change is stopped to avoid an overcurrent fault. • When the output current exceeds the setting during constant speed operation, the frequency decreases to maintain constant torque. • When the DC voltage exceeds the limit during deceleration, the speed change stops to avoid an overvoltage fault. 								
Input phase loss protection	The drive is protected against input voltage phase loss.								
Output phase loss protection	An unbalance in the impedance of the output circuit is detected and outputs an alarm. (Error during tuning only)								
Auto reset	The number of retries and wait time can be set before an alarm stop.								
Installation location	<ul style="list-style-type: none"> • Indoors • Locations without corrosive gases, flammable gases or dust (degree of pollution: 2) • Locations without direct sunlight 								
Ambient temperature	-10 to +40°C								
Relative humidity	5 to 95% RH (without condensation)								
Altitude	1000 meters max. (Atmospheric pressure 86 to 106 kPa)								
Vibration	<table border="0"> <tr> <td>3mm</td> <td>2 to 9 Hz</td> </tr> <tr> <td>9.8m/s²</td> <td>9 to 20 Hz</td> </tr> <tr> <td>2m/s²</td> <td>20 to 55 Hz</td> </tr> <tr> <td>1m/s²</td> <td>55 to 200 Hz</td> </tr> </table>	3mm	2 to 9 Hz	9.8m/s ²	9 to 20 Hz	2m/s ²	20 to 55 Hz	1m/s ²	55 to 200 Hz
3mm	2 to 9 Hz								
9.8m/s ²	9 to 20 Hz								
2m/s ²	20 to 55 Hz								
1m/s ²	55 to 200 Hz								
Storage temperature	-25 to +65°C								
Storage humidity	5 to 95% RH (without condensation)								

9.3 External Dimensions

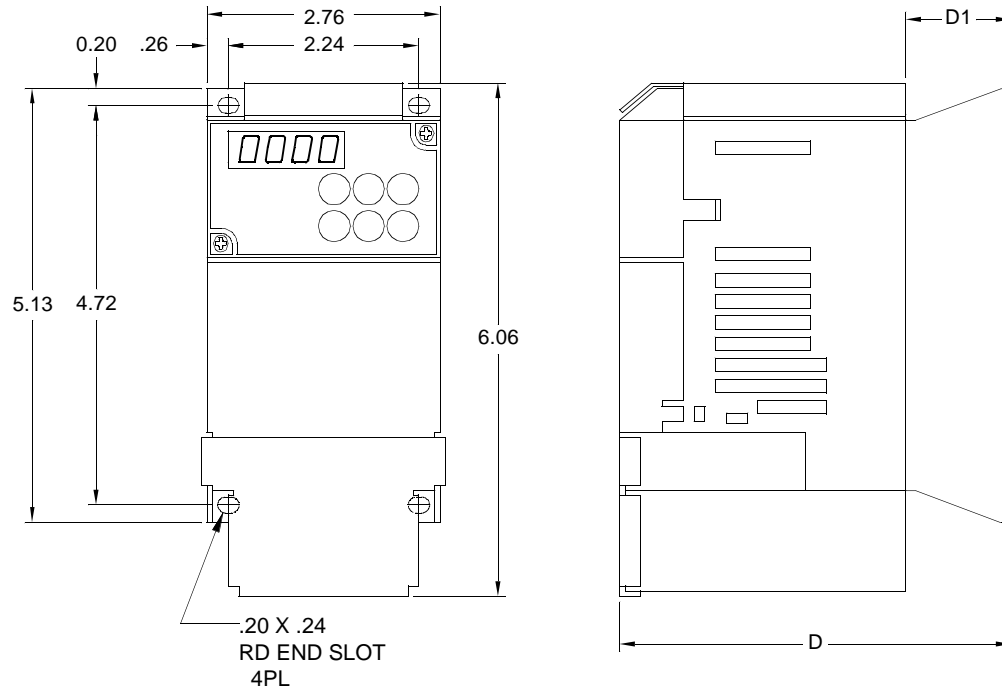

CATALOG NO.	NOMINAL MOTOR HP	D	D1
ACE202V3P0001N1	1/8	3.98	.39
ACE202V3P0002N1	1/4	3.98	.59
ACE202V3P0005N1	1/2	4.65	1.26
ACE202V3P0010N1	1	5.67	2.28

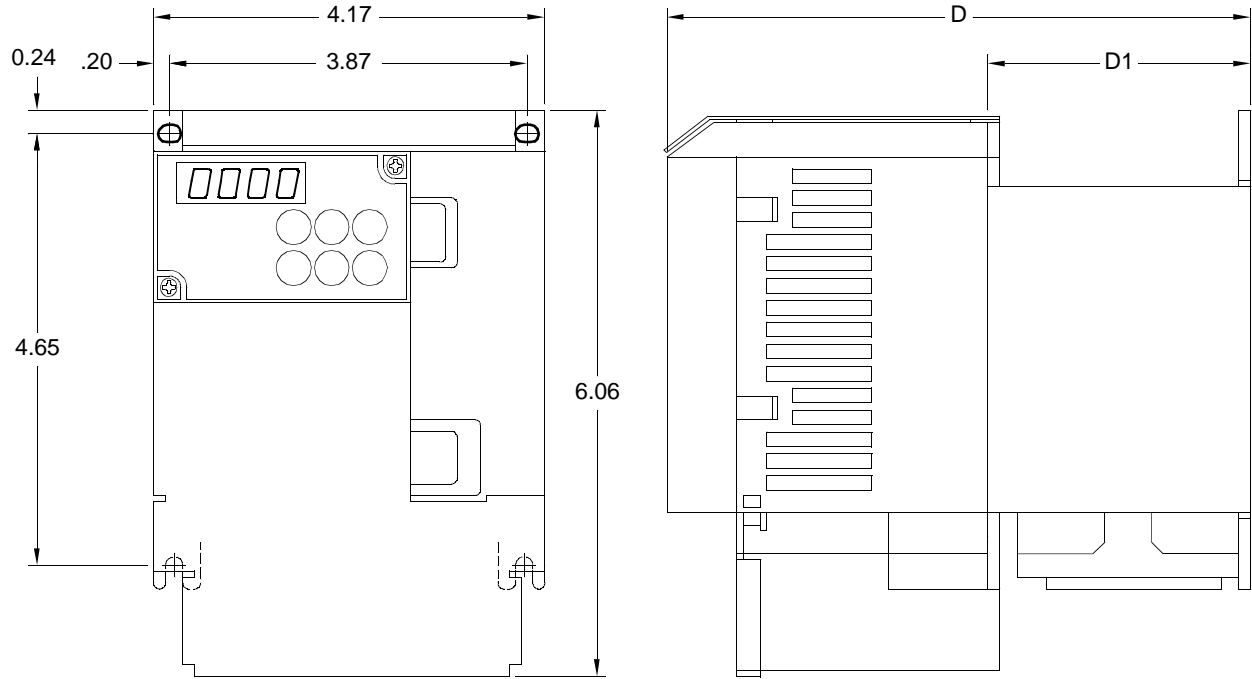

CATALOG NO.	NOMINAL MOTOR HP	D	D1
ACE202V3P0020N1	2	5.91	2.52
ACE202V3P0030N1	3	5.91	2.52
ACE204V3P0005N1	1/2	4.96	1.57
ACE204V3P0010N1	1	5.91	2.52
ACE204V3P0020N1	2	6.69	2.52
ACE204V3P0030N1	3	6.69	2.52

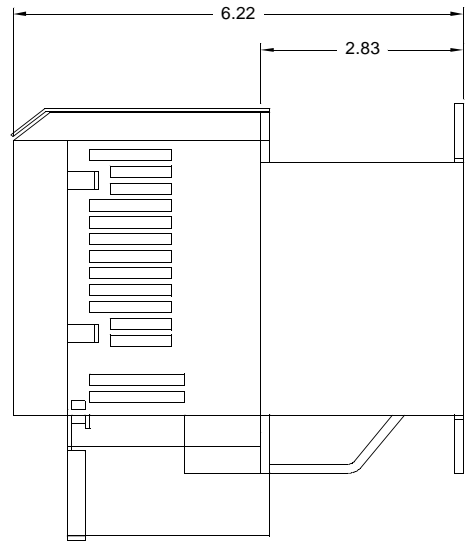
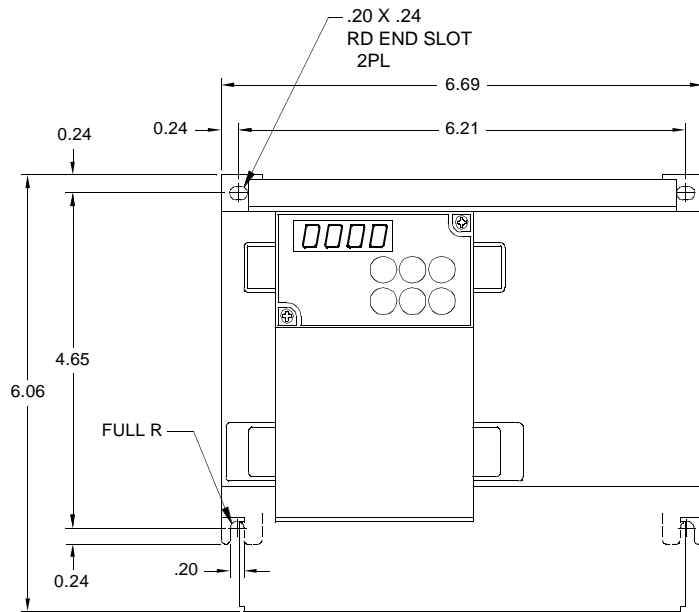

CATALOG NO.	NOMINAL MOTOR HP
ACE202V3P0050N1	5
ACE204V3P0050N1	5

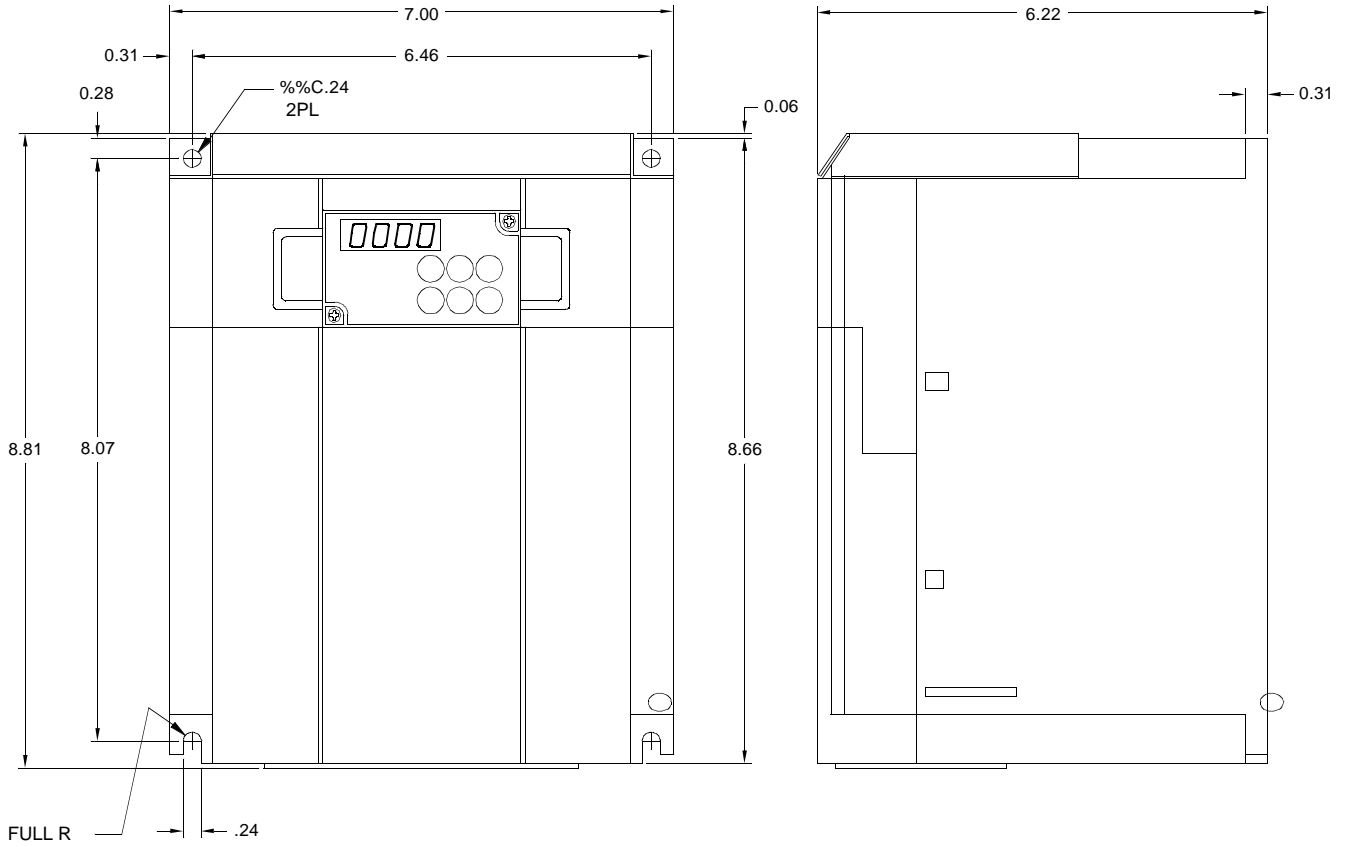

CATALOG NO.	NOMINAL MOTOR HP
ACE202V3P0075N1	7-1/2
ACE202V3P0100N1	10
ACE204V3P0075N1	7-1/2
ACE204V3P0100N1	10