



**Boston Gear**  
14 Hayward Street  
Quincy, MA 02171

tel 617.328.3300  
fax 617.479.6238

ACE10UG  
08/03

**\* ACE 10 SERIES \***  
**ADJUSTABLE-FREQUENCY**  
**AC MOTOR CONTROLLERS**  
**USER'S GUIDE**  
**(1/4 - 3 HP)**

An ACE 10 Series Technical Manual (ACE10TM) is available on line at our website ([BostonGear.com](http://BostonGear.com)) or by calling 888-999-9860. For application support, call 800-816-5608.

MODEL NO. \_\_\_\_\_

SERIAL NO. \_\_\_\_\_

INPUT SUPPLY \_\_\_\_\_ VAC, 50/60 Hz

HORSEPOWER \_\_\_\_\_

---

---

# TABLE OF CONTENTS

<b>Foreword</b> .....	3
1. Safety Precautions .....	3
<b>1. Safety Precautions</b>	
1.1 Precautions for Operation .....	4
<b>2. Hardware Instructions and Installation</b>	
2.1 Operation Environment .....	7
2.2 Model No. Identification .....	8
2.3 Specifications .....	9
2.4 Wiring Diagrams .....	13
2.5 Dimensions & Location of Terminal Block .....	16
<b>3. Software Index</b>	
3.1 Keypad Operating Instructions .....	21
3.2 Parameter List .....	22
3.3 Malfunction Indications and Countermeasures .....	26
3.4 General Malfunction Examination Method .....	29

---

---

# FOREWORD

To fully use all functions of this AC Drive, and to ensure the safety for its users, please read through this user's guide in detail. If you have any further questions, please feel free to contact your local distributor or regional representative.

## 1. SAFETY PRECAUTIONS

The AC Drive is a power electronic device. For safety reasons, please read carefully those paragraphs with "WARNING" and "CAUTION" symbols. They are important safety precautions to be aware of while transporting, installing, operating or examining the AC drive. Please follow these precautions to ensure your safety.

 **WARNING** Personal injury may occur from improper operation.

 **CAUTION** The AC Drive or mechanical system may be damaged by improper operation.

### **WARNING**

- Do not touch the PCB or components on the PCB after turning off the power before the charging indicator is turned off.
- Do not attempt to wire circuitry while power is on. Do not attempt to examine components and signals on the PCB while the drive is operating.
- Do not attempt to disassemble or modify internal circuitry, wiring, or components of the controller.
- The grounding terminal of the controller must be grounded properly to 200V class type III standard.
- This is a product of the restricted sales distribution class according to EN61800-3.

In a domestic environment, this product may cause radio interference in which case the user may be required to take adequate measures.

### **CAUTION**

- Do not attempt to perform dielectric strength test to internal controller components. There are sensitive semiconductor devices vulnerable to high voltage in the controller.
- Do not connect the output terminals: T1 (U), T2 (V), and T3 (W) to AC power.
- The CMOS IC on the primary PCB of the controller is vulnerable to static electrical charges. Do not contact the primary PCB of the controller.

---

---

# 1. SAFETY PRECAUTIONS

## 1.1 PRECAUTIONS FOR OPERATION

### *Before turning ON power*

**⚠ CAUTION**

Choose the appropriate power source with the correct voltage for the input power to the AC controller.

**⚠ WARNING**

The input power source must be connected to the L1 and L2 (or L1, L2 or L3) terminals, and must not be mistakenly connected to the T1, T2 or T3 output terminals. This may damage the controller when power is turned on.

**⚠ CAUTION**

- Do not attempt to carry the controller by the front of the cover. Securely hold the controller by the heat-sink mounting chassis to prevent the controller from falling, as this may cause personal injury or damage to the controller.
- Install the controller onto a firm metal base plate or other non-flammable type material. Do not install the controller onto or nearby any flammable material.
- An additional cooling fan may be needed if several controllers are installed onto one control panel. The temperature inside an enclosed panel should be below 40 degrees C (104 degrees F) to avoid overheating.
- Turn off the power supply before proceeding to remove or perform any work on any panel. Carry out installation procedures according to instructions given in order to avoid an operation malfunction.
- The AC controller is for use on a circuit capable of delivering not more than 5000 RMS symmetrical amperes.
- The controller is not provided with overspeed protection.
- The controller is only intended for use in a pollution degree 2 environment or equivalent.

---

---

## ***When power is applied:***

### **! WARNING**

- Do not install or remove input or output controller connections when the power supply is turned on. Otherwise, the controller may be damaged due to the surge peak caused by the application or removal of power.
- When momentary power loss is longer than 2 seconds (the larger the horsepower, the the longer the time), the controller does not have enough storage power to retain control. Therefore, when power is reapplied, the operation of the controller is based on the setup of F\_10 and the condition of an external switch (FWD/REV button). This is considered to be a restart in the following paragraphs.
- When the momentary power loss is short, the controller still has enough storage power to retain control. Therefore, when power is reapplied, the controller will automatically start operation again, depending on the setup of F\_23.

When the controller restarts, the operation is based on the setup of F\_10, and the condition of an external switch (FWD/REV button). The restart operation is irrelevant with F\_23/F\_24.

(1) When F\_10 = 0, the controller will not start after restart.

(2) When F\_10 = 1 and the external switch (FWD/REV button) is OFF, the controller will not start after a restart command.

(3) When F\_10 = 1 and the external switch (FWD/REV button) is ON, the controller will start automatically after a restart command. For safety reasons, turn off the external switch (FWD/REV button) after a power loss to avoid possible damage to the machine and personal injury after sudden regeneration of power.

## ***During Operation:***

### **! WARNING**

Do not use a separate device to switch the motor ON or OFF during operation. Otherwise, the controller may experience an over-current breakdown.

### **! WARNING**

- Do not remove the controller front cover when the power is ON to avoid personal injury caused by electrical shock.
- When the automatic restart function is enabled, the motor and machinery will restart automatically.

---

---

**▲ CAUTION**

- Do not touch the heat-sink base during operation.
- The controller can be easily operated from a low-speed to high-speed range.  
Reconfirm the operating range of the motor and the machinery you are controlling.
- Do not examine the signals on the PCB of the controller during operation.
- All controllers are properly adjusted and set before delivery.

**▲ CAUTION**

Do not disassemble or examine the controller before ensuring that the power source is off and the Power LED is not lit.

***When performing an examination or maintenance:***

**▲ CAUTION**

The controller environment should be within:  $-10^{\circ}\text{C} \sim +40^{\circ}\text{C}$  ( $14^{\circ}\text{F} \sim 104^{\circ}\text{F}$ ), with humidity under 95% RH without condensing.

**▲ CAUTION**

After the removing the shield sticker, the environment should be within:  $-10^{\circ}\text{C} \sim +50^{\circ}\text{C}$  ( $14^{\circ}\text{F} \sim 122^{\circ}\text{F}$ ), with humidity under 95% RH without condensing.  
The controller should be free from water dripping and metal dust.

---

---

## 2. HARDWARE INSTRUCTIONS AND INSTALLATION

### 2.1 OPERATION ENVIRONMENT

The installation site of the controller is very important. It relates directly to the functionality and the life span of your controller. Carefully choose the installation site to meet the following requirements:

- Mount the controller vertically
- Environment temp:  $-10^{\circ}\text{C} \sim +40^{\circ}\text{C}$  ( $14^{\circ}\text{F} \sim 104^{\circ}\text{F}$ ) (w/o shield sticker:  $-10^{\circ}\text{C} \sim +50^{\circ}\text{C}$  ( $14^{\circ}\text{F} \sim 122^{\circ}\text{F}$ ))
- Avoid placing the controller close to any heating equipment
- Avoid water dripping and humid environment
- Avoid direct sunlight
- Avoid oil and salty corrosive gas
- Avoid contacting corrosive liquid and gas
- Prevent foreign dust, flocks, and metal scraps from entering the controller interior
- Avoid electrical-magnetic interference (soldering or power machinery)
- Avoid vibration. If vibration cannot be avoided, an anti-vibration mounting device should be installed to reduce vibration.
- If the controller is installed on an enclosed control panel, remove the shield sticker located at the top of the controller. This will allow additional airflow and cooling.

*External Fan Placement needs to be over the top of the controller.*

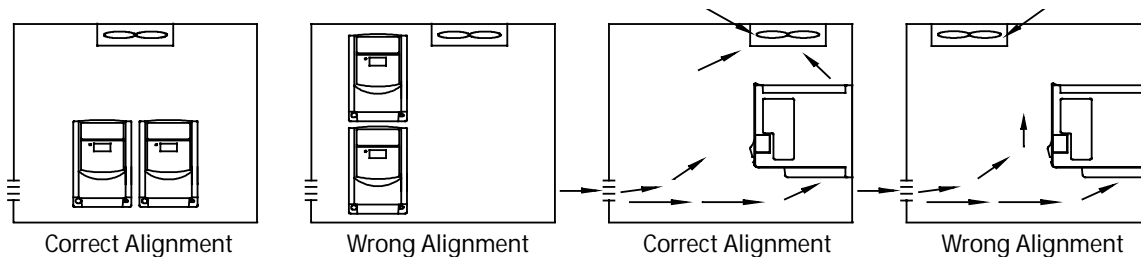

- For proper Installation of the controller, place the front of the controller facing front and the top of the controller in the up direction for better heat dissipation.
- Installation must be compliant with the following requirements:

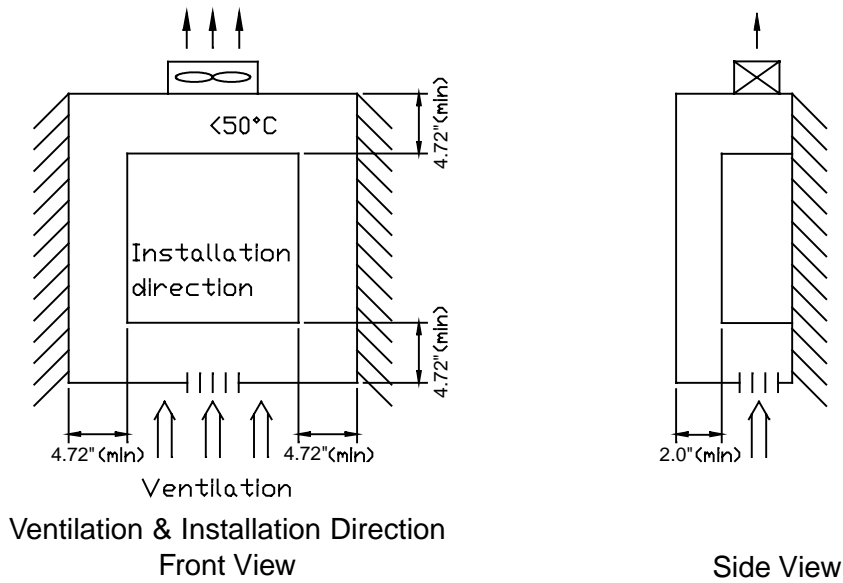

Note: Maximum temperature in the enclosure: 50°C (122°F)

## 2.2 MODEL NO. IDENTIFICATION

CATALOG NUMBER	ITEM CODE	TYPE	HP RATING	VOLTAGE	PHASE	AMPS
ACE101V1P0002C	43285	Chassis	1/4	115	1	1.4
ACE101V1P0005C	43286		1/2			2.3
ACE101V1P0010C	43287		1			4.2
ACE102V1P0002C	43288		1/4	230	1	1.4
ACE102V1P0005C	43289		1/2			2.3
ACE102V1P0010C	43290		1			4.2
ACE102V3P0020C	43291		2	460	3	7.5
ACE102V3P0030C	43292		3			10.5
ACE104V3P0010C	43293		1			2.3
ACE104V3P0020C	43294		2	460	3	3.8
ACE104V3P0030C	43295		3			5.2
ACE101V1P0002N4	43296		NEMA 4			1/4
ACE101V1P0005N4	43297	1/2		2.3		
ACE101V1P0010N4	43298	1		4.2		
ACE102V1P0002N4	43299	1/4		230	1	1.4
ACE102V1P0005N4	43300	1/2				2.3
ACE102V1P0010N4	43301	1				4.2
ACE102V3P0020N4	43302	2		460	3	7.5
ACE102V3P0030N4	43303	3				10.5
ACE104V3P0010N4	43304	1				2.3
ACE104V3P0020N4	43305	2		460	3	3.8
ACE104V3P0030N4	43306	3				5.2

a. Can be operated at single phase without derating.

## 2.3 SPECIFICATIONS

### 2.3.1 Basic Specifications

Model	Chassis	
	ACE101V1P0002C	ACE101V1P0005C
Suitable Motor Power Rating (kW)		
Motor (HP)	1/4	1/2
Output Current (A)	1.4	2.3
Capacity (KVA)	0.53	0.88
Weight (lbs)	1.7	1.7
Chassis		
NEMA 4		
Input Voltage, Maximum		
Single Phase 100-120 VAC (+10%, -15%), 50/60 Hz (+/-5%)		
Output Voltage, Maximum		
Three Phase 200-240 VAC (Proportional to input voltage)		
Dimensions W*H*D (Inches)		
2.83 x 5.16 x 4.65		
EMC Specification		
NEMA 4		
Without Filter		

Model	Chassis	
	ACE102V1P0002C	ACE102V1P0005C
Suitable Motor Power Rating (kW)		
Motor (HP)	0.2	0.4
Output Current (A)	1/4	1/2
Capacity (KVA)	1.4	2.3
Weight (lbs)	0.53	0.88
Chassis		
NEMA 4		
Input Voltage, Maximum		
Single Phase 200-240 VAC (+10%, -15%), 50/60 Hz (+/-5%)		
Output Voltage, Maximum		
Three Phase 200-240 VAC (Proportional to input voltage)		
Dimensions W*H*D (Inches)		
2.83 x 5.16 x 4.65		
EMC Specification		
NEMA 4		
Class A (Single phase filter built in)		

Model	Chassis	
	ACE104V3P0010C	ACE104V3P0020C
Suitable Motor Power Rating (kW)		
Motor (HP)	0.75	1.5
Output Current (A)	1	2
Capacity (KVA)	2.3	3.8
Weight (lbs)	1.7	2.9
Chassis		
NEMA 4		
Input Voltage, Maximum		
Three Phase 380-480 VAC (+10%, -15%), 50/60 Hz (+/-5%)		
Output Voltage, Maximum		
Three Phase 380-480 VAC (Proportional to input voltage)		
Dimensions W*H*D (Inches)		
4.65 x 5.63 x 6.77		
EMC Specification		
NEMA 4		
Class A (Three phase filter built in)		

## 2.3.2 Functional Specifications

Item		Specification
Input Signal Type		PNP type (SOURCE) input (External 24 VDC input is allowed)
Control Method		Sinusoidal wave PWM control
<b>Frequency Control</b>	Frequency Range	1 - 200 Hz
	Resolution Setting	Digital: 0.1 Hz (1 - 99.9 Hz); 1 Hz (100 - 200 Hz) Analog: 1 Hz / 60 Hz
	Keypad Setting	Direct setup by ▲▼ buttons
	External Signal Setting	0 - 10V, 4 - 20mA, 0 - 20mA
	Other Function	Frequency upper and lower limit
<b>General Control</b>	Carrier Frequency	4 - 16 KHz
	Accel/Decel Time	0.1 - 999 seconds
	V/F Pattern	6 patterns
	Torque control	Torque boost level adjustable (manual torque boost)
	Multi-functional Input	2 point, to be used as multi-speed 1(Sp. 1) / multi-speed 2(Sp. 2) / Jog / External emergency stop / External bb / Reset
	Multi-functional Output	1a relay terminal, to be set up as Fault / Running / Frequency
	Braking Torque	About 20%. 20 - 100% with built -in braking transistor
Other Function	Decelerate or free run stop, Auto reset, DC braking frequency / Voltage / Time can be set up by constants	
Display		Three LED's display frequency / drive parameter / fault record / program version
Operating Temperature		-10 - +40° C (14 - 104° F) (without shield sticker: -10 - +50° C (14 - 122° F))
Humidity		0 - 95% RH non-condensing
Vibration		Under 1G (9.8 m/s <sup>2</sup> )
EMC Specification		EN5008-1, EN5008-2, EN50082-1, EN50082-2, EN50178
UL		UL508C
<b>Protection Function</b>	Overload	150% for 1 minute
	Over Voltage	DC voltage > 410V(100/200 series); DC voltage > 800V(400 series)
	Under Voltage	DC voltage < 200V(100/200 series); DC voltage < 400V(400 series)
	Momentary Power Loss	0 - 2 seconds: The drive can be restarted using speed search feature.
	Stall Prevention	During Acceleration / Deceleration / Constant speed
	Output Short-circuit	Electronic circuitry protection
	Grounding Fault	Electronic circuitry protection
	Other Function	Heat sink overheat protection, Current limit
Installation		Mounting screw or DIN rail (option)

### 2.3.3 Suitable Optional and Wiring Specifications

#### Molded-Case Circuit Breaker / Magnetic Contact

● **Warranty does not apply to damage caused by the following situations:**

(1) Damage to the controller caused by the lack of appropriate molded-case circuit breaker or when a circuit breaker with too large of capacity is installed between the power supply and the controller.

(2) Damage to the controller caused by a magnetic contact, phase advancing capacitor, or surge-protector installed between the controller and the motor.

Controller Rating	1.4/2.3A, 115/230V	4.2/7.5A, 115/230V	10.5A, 230V	2.3/3.8/5.2A, 460V
Molded-case circuit breaker	15A	20A	30A	15A
Primary Circuit Terminal (TM1) L1 L2 L3* T1 T2 T3 * Terminal L3 is on three phase controllers only.	Wire dimension (#14AWG) 2.0mm <sup>2</sup> Terminal screw M3	Wire dimension (#14AWG) 2.0m m <sup>2</sup> Terminal screw M3/M4	Wire dimension 3.5mm <sup>2</sup> Terminal screw M4	Wire dimension 3.5mm <sup>2</sup> Terminal screw M4
Signal Terminal (TM2) 1~11	Wire dimension 0.75mm <sup>2</sup> (#18 AWG), Terminal screw M3			

Use copper conductors only. Size field wiring based on 80 degrees C wire only.

- Use a three-phase squirrel-cage induction motor with appropriate rating.
- If the controller is used to drive more than one motor, the total motor current must be less than the controller current rating. Additional thermal overload relays must be installed in series with each motor. Use the  $F_n_{18}$  at 1.0 times the rated value specified on the motor nameplate at 50Hz, 1.1 times the rated value specified on the motor nameplate at 60Hz.
- Do not install phase advancing capacitors, LC, or RC components between the controller and motor.

---

---

### ***2.3.4 Application and precautions of peripherals***

#### **From the power source:**

- Be sure the power source is rated correctly to prevent damaging the controller.
- A power disconnect or circuit breaker must be installed between the AC power supply and the controller.

#### **Molded-case circuit breaker:**

- Use a correctly sized circuit breaker to protect the controller.
  
- Do not use the circuit breaker to switch power ON or OFF to the controller. The circuit breaker should be used only to provide protection.

#### **Leakage circuit breaker:**

- An earth leakage circuit breaker should be added to prevent false operation cause by leakage current, and to ensure personal safety.

#### **Magnetic contactor:**

- A magnetic contactor can usually be omitted. However, to utilize external control, automatic restart, or braking the controller, a magnetic contactor must be added at the primary side.
- Do not use a magnetic contactor to switch power ON or OFF to the controller.

#### **Power improvement AC reactor:**

- If a large capacity power source is applied (over 600 KVA), an additional AC reactor may be added to improve power factor.

#### **Controller:**

- The power supply input terminals (L1, L2 and L3) are not sensitive to phase sequence. They can be arbitrarily connected. Also, their connections may be interchanged.
- Output terminals T1, T2, and T3 should be connected to motor terminals U, V, and W, respectively. If the motor turns in the opposite direction of the controller command, simply exchange two of the three motor connections to correct this problem.
- Output terminals T1, T2, and T3 must not be connected to a power source. Otherwise, the controller may become damaged.

## 2.4 WIRING DIAGRAMS

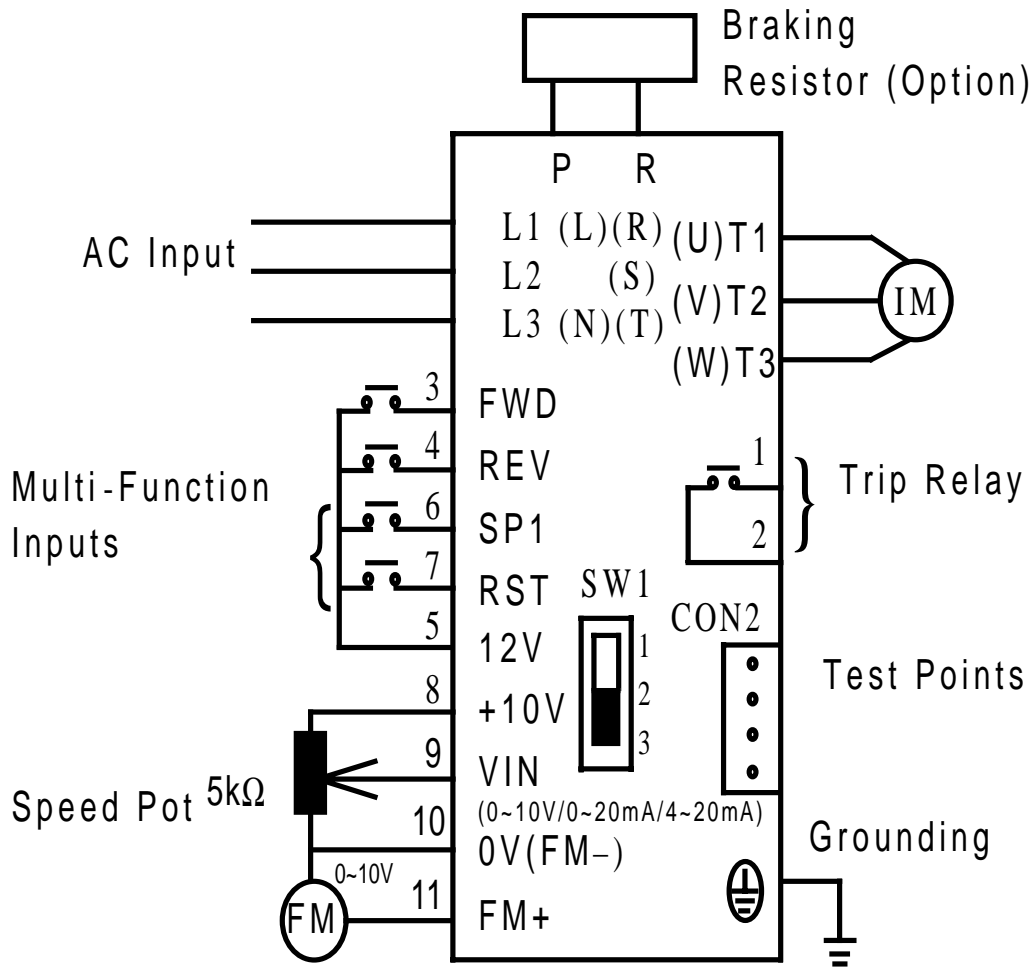

- Grounding circuitry must not be formed when grounding several controllers together.

Use appropriate wire with correct diameter for primary power circuitry and control circuitry in accordance with electrical regulations.

### **External 24V supply**

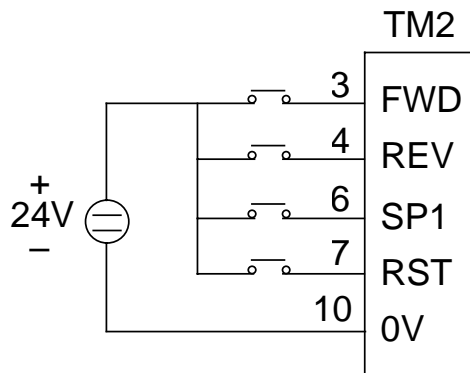

PARAMETER SETTING	SETTINGS	
	EXTERNAL SPEED CONTROL	KEYPAD SPEED CONTROL
F03 OPERATION MODE	0	0
F10 START STOP CONTROL	1	1
F11 FREQUENCY CONTROL	1	0

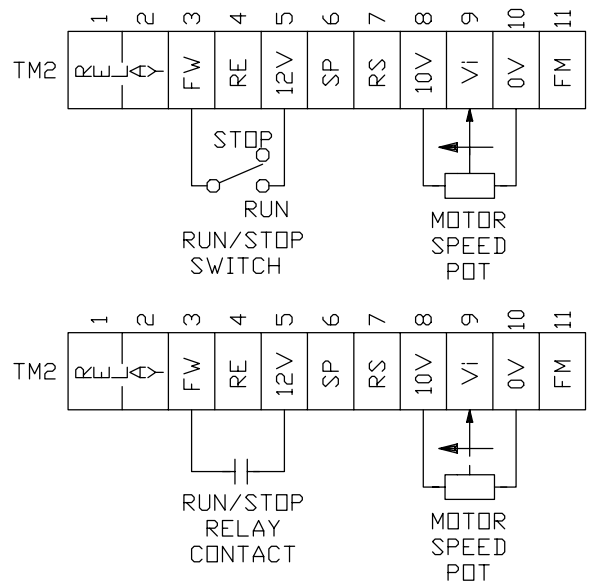

FIGURE 1.

RUN STOP OPERATION BY SWITCH OR RELAY CONTACT WITH SPEED CONTROL BY SPEED POT OR KEYPAD

PARAMETER SETTING	SETTINGS	
	EXTERNAL SPEED CONTROL	KEYPAD SPEED CONTROL
F03 OPERATION MODE	0	0
F10 START STOP CONTROL	1	1
F11 FREQUENCY CONTROL	1	0

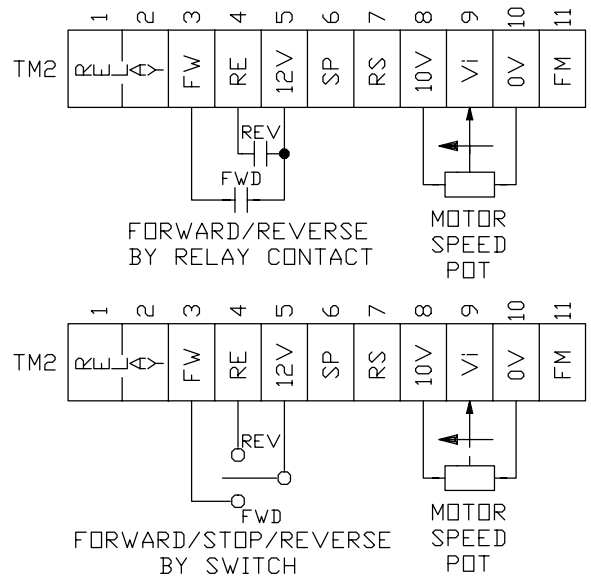

FIGURE 2.

FORWARD STOP REVERSE OPERATION BY SWITCH OR RELAY CONTACT WITH SPEED CONTROL BY SPEED POT OR KEYPAD

## Controller Terminal Descriptions

### Primary Circuitry Terminal Block (TM1) description

Terminal Symbol	Function Description
L1/L (R)	Primary power source (line voltage) input to the controller
L2 (S)	
L3/N (T)	
P	External braking resistor terminal (Only for 2 & 3HP, 230V & 1 - 3HP, 460V)
R	
T1 (U)	Controller output to the motor
T2 (V)	
T3 (W)	

Tightening torque for TM1 is 1 LB-FT or 12 LB-IN (1/4HP - 1/2HP, 115V & 1/4 - 1HP, 230V).

Tightening torque for TM1 is 1.3 LB-FT or 16 LB-IN (2 - 3HP, 230V & 1 - 3HP, 460V).

\* Wire voltage rating must be a minimum of 300V(200V series) / 600V(400V series).

### Control Circuitry Terminal Block (TM2) description

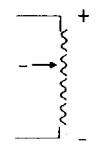
Terminal Symbol	Function Description		
1	TRIP	Fault relay output terminal. Multifunction output terminal (refer to F_21) Connection point rated 250VAC @ 1A (30VDC @ 1A)	
2	RELAY		
3	FWD (FW)	Operation control terminals (refer to F_03)	
4	REV (RE)		
5	+ 12V(12)	Common point of terminals 3, 4, 6 & 7	
6	SP1(SP)	Multifunction input terminals (refer to F_19)	
7	RESET(RS)		
8		+10V	Power terminal for potentiometer (Pin 3)
9		Analog input wire Wiper	Analog frequency signal input terminal (Pin 2 of potentiometer or positive terminal of 0~10V / 4~20mA / 0~20mA)
10	0V(FM -)	Analog common point	Analog signal common point (Pin 1 of potentiometer or negative terminal of 0~10V / 4~20mA / 0~20mA)
11	FM+	Analog output positive connection point	Analog frequency signal output terminal Output terminal signal is 0 ~ 10VDC/Fn6



Tightening torque for TM2 is 0.42 LB-FT or 5.03 LB-IN.

\* Wire voltage rating must be a minimum of 300V.

\* Control wiring should not be run in the same conduit or raceway with power or motor wiring.

\* Single Input and Output Terminals (TM2): Ratings are all Class 2.

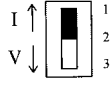
## SW1 function description

SWITCH 1	External signal type
	0~20mA analog signal (When F_11 is set to 1)
	4~20mA analog signal (When F_11 is set to 2)
	0~10 VDC analog signal (When F_11 is set to 1)

## 2.5 DIMENSIONS & LOCATION OF TERMINAL BLOCK

1/4-1HP, 115/230V:

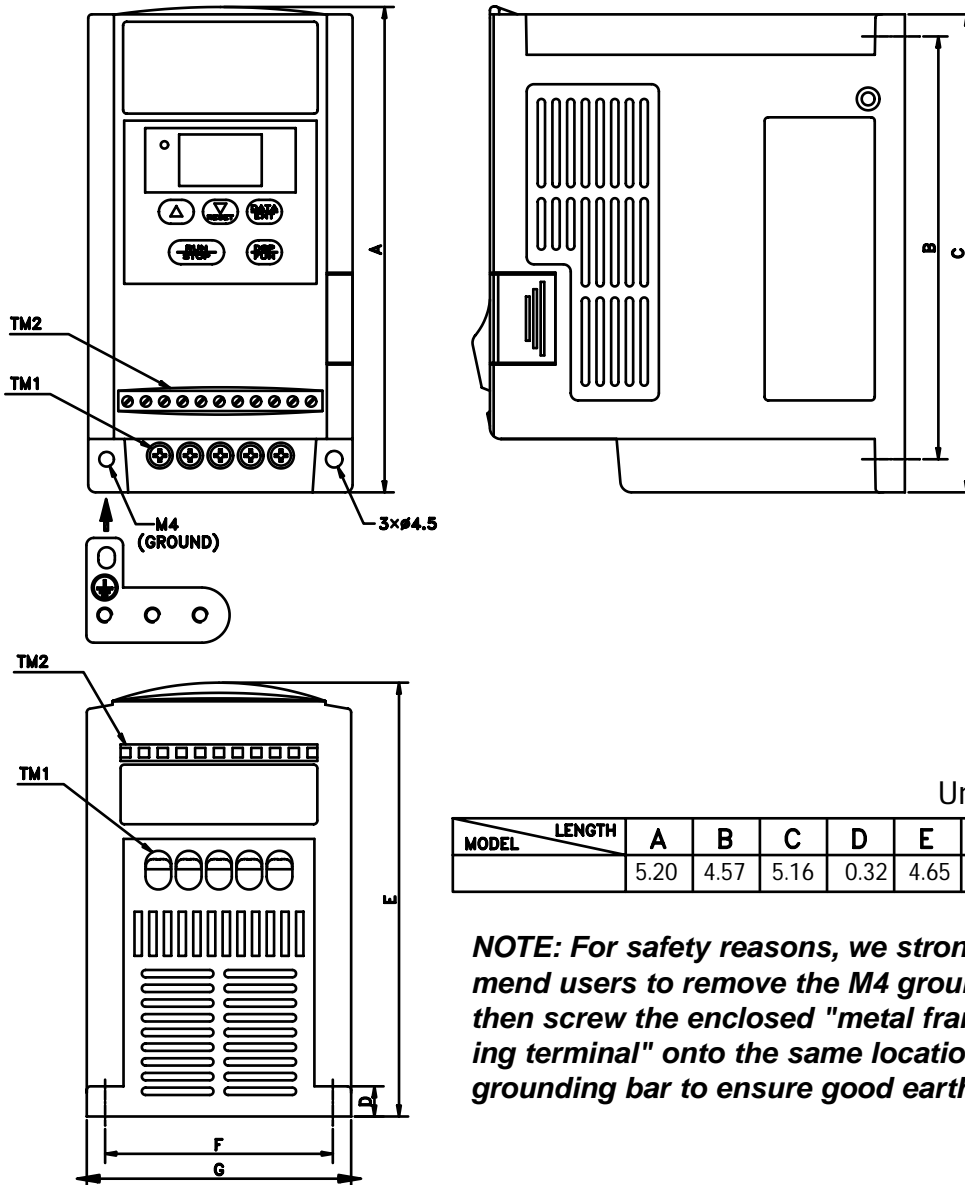

2-3HP, 230V & 1-3HP, 460V:

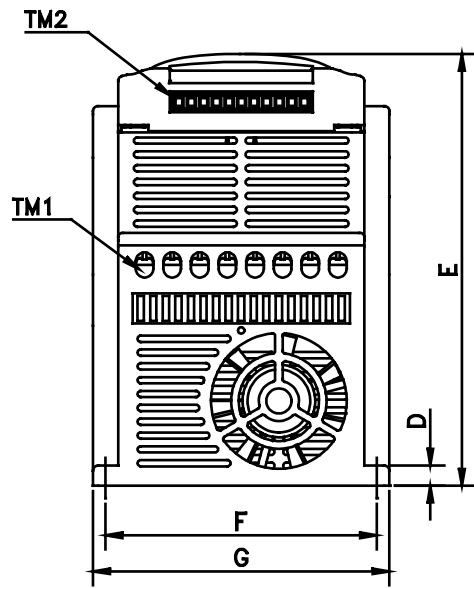
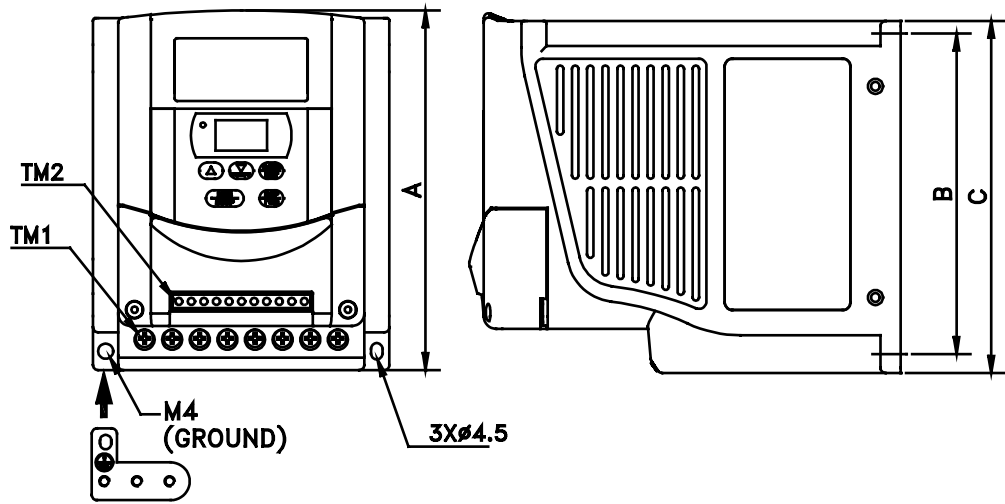

Unit:inches

A	B	C	D	E	F	G
5.63	5.02	5.63	0.32	6.77	4.25	4.65



---

---

**NEMA 4 - 2-3HP, 230V & 1-3HP, 460V:**

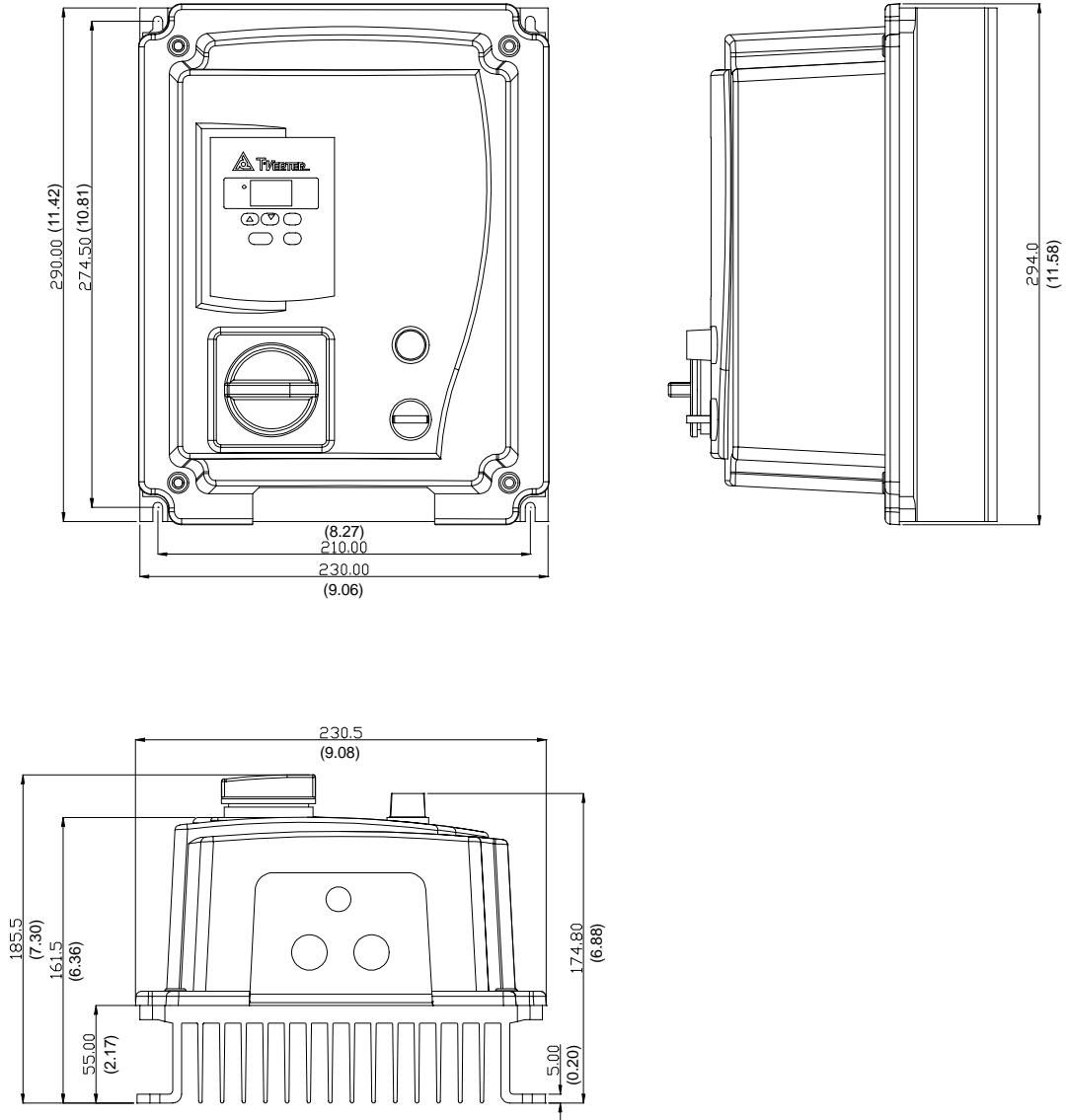

**UNIT: mm (Inches)**

Operator controls shown are optional

---

---

## TYPICAL NEMA 4 CONNECTIONS AND EMC MOUNTING:

(Single Phase Input Shown)

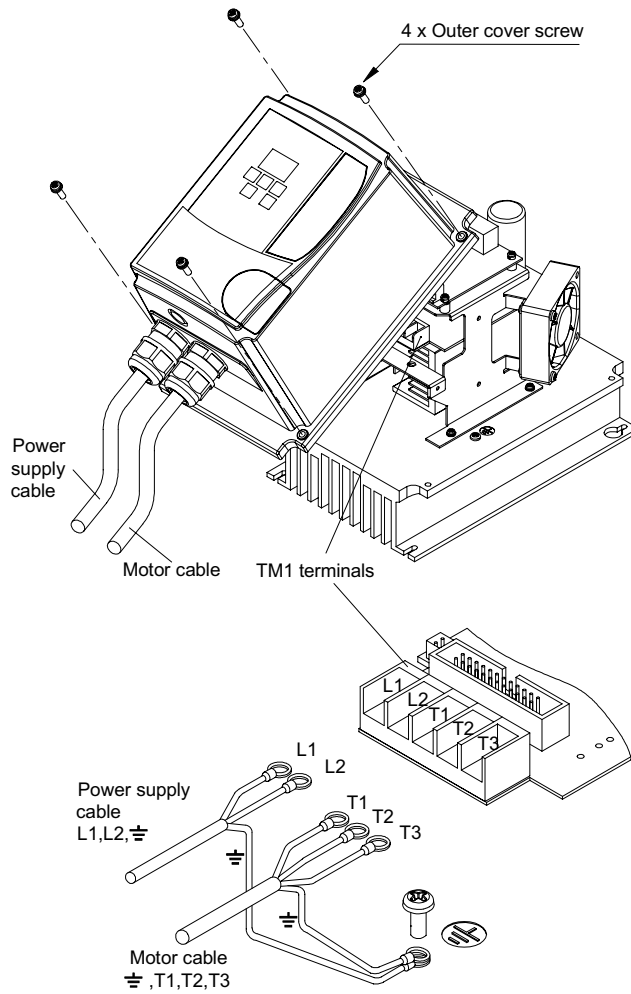

## EMC MOUNTING

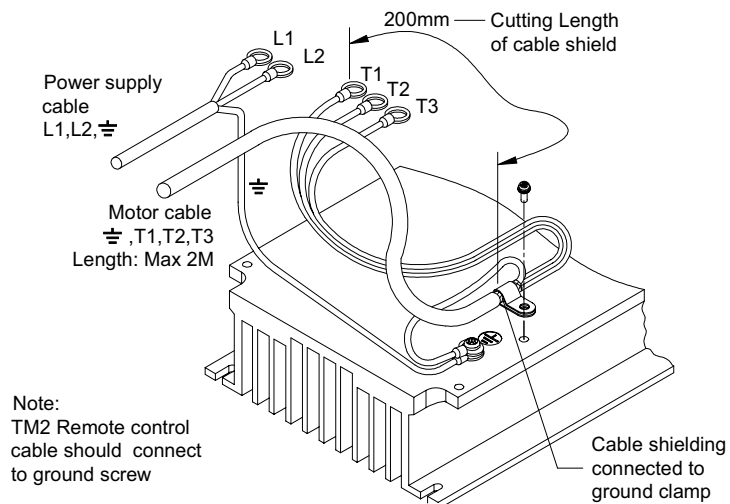



## 3.2 PARAMETER LIST

Function	F_	Function Description	Unit	Range	Factory Setting	Page	Note
	0	Factory Adjustment			0		
Acceleration time	1	Accel. time	0.1Sec	0.1 ~ 999 S	5.0		*1 *3
Deceleration time	2	Decel. time	0.1Sec	0.1 ~ 999 S	5.0		*1 *3
Operation mode	3	0: Forward / Stop, Reverse / Stop 1: Run/Stop, Forward / Reverse	1	0 1	0		
Motor rotation direction	4	0: Forward 1: Reverse	1	0 1	0		*1
V/F pattern	5	V/F pattern setting	1	1 ~ 6	1/4	23	*2
Frequency upper/lower limit	6	Frequency upper limit	0.1Hz	1 ~ 200	50/60Hz		*2 *3
	7	Frequency lower limit	0.1Hz	1 ~ 200	0.0Hz		*3
SPI frequency	8	SP1 frequency	0.1Hz	1 ~ 200	10Hz		*3
JOG frequency	9	JOG frequency	0.1Hz	1 ~ 200	6Hz		
Start / Stop control	10	0: Keypad 1: Terminal (TM2)	1	0 1	~ 0		
Frequency control	11	0: Keypad 1: Terminal (0~10v / 0~20mA) 2: Terminal (4~20mA)	1	0 2	~ 0		
Carrier frequency control	12	Carrier frequency setting	1	1 ~ 10	5	24	
Torque compensation	13	Torque compensation gain	0.1%	0.0 ~ 10.0%	0.0%*		*1
Stop method	14	0: Controlled deceleration stop 1: Coast to stop	1	0 1	~ 0		
DC braking setting	15	DC braking time	0.1S	0.0 ~ 25.5S	0.5S		
	16	DC braking injection frequency	0.1Hz	1 ~ 10Hz	1.5Hz		
	17	DC braking level	0.1%	0.0 ~ 20.0%	8.0%		
Electronic thermal overload protection	18	Protection based on motor rated current	1%	0 ~ 200%	100%		
Multifunction input connection point	19	Multifunction input terminal 1 (SP1) function	1: Jog 2: SP1 3: Emergency stop		2		
	20	Multifunction input terminal 2 (RESET) function	4: External base block 5: Reset 6: SP2		5		
Multifunction output	21	Multifunction output terminal	1: Operating 2: Frequency reached 3: Fault		3		

Function	F_	Function Description	Unit	Range	Factory Setting	Page	Note
Reverse lock-out	22	0: REV run 1: REV run lock-out	1	0 1	0		
Momentary power loss	23	0: Enabled 1: Disabled	1	0 1	~ 0		
Auto restart	24	Number of auto-restart times	1	0 ~ 5	0		
Factory setting	25	010: Constants default to 50Hz system 020: Constants default to 60Hz system				24	*2
SP2 frequency	26	SP2 frequency	0.1Hz	1.0~200Hz	20		
SP3 frequency	27	SP3 frequency	0.1Hz	1.0~200Hz	30		
Direct start	28	0: Enabled 1: Disabled	1	0 1	~ 1		
Software version	29	CPU program version					
Fault log	30	Fault log for three faults.					

**NOTES:**

\*1: Indicates this parameter can be adjusted during running mode.

\*2: Refer to F\_25.

\*3: If the setting range is above 100, the setting unit becomes 1.

Function descriptions are available in Manual ACE10TM. This manual is available at our Web Site ([BostonGear.com](http://BostonGear.com)).

**F\_05: V/F Pattern Setting = 1 ~ 6**

Set F\_05 = 1-6 to select one of the six preset V/F patterns. (Refer to the following tables.)

Specification	50 Hz System		
Application	General application	High starting torque	Decreasing torque
F_5	1	2	3
V/F pattern			
Specification	60Hz System		
Application	General application	High starting torque	Decreasing torque
F_5	4	5	6
V/F pattern			

F_5	B	C
1/4	10%	8%
2/5	15%	10.5%
3/6	25%	7.7%

**F\_12: Carrier Frequency = 1 ~ 10**

<b>F_12</b>	<b>Carrier frequency</b>	<b>F_12</b>	<b>Carrier frequency</b>	<b>F_12</b>	<b>Carrier frequency</b>
1	4 kHz	5	8 kHz	9	15 kHz
2	5 kHz	6	10 kHz	10	16 kHz
3	6 kHz	7	12 kHz		
4	7.2 kHz	8	14.4 kHz		

**NOTE:**

If F\_12 = 7~10, the drive must operate with a light load.

Although an IGBT type controller can provide a low audible noise level during operation, it is possible that the switching of the high carrier frequency may interfere with external electronic components (or other controllers) or even cause vibration in the motor. Adjusting the carrier frequency can usually correct this problem.

**F\_25: Return to Factory Settings = 010: Parameters restored to 50Hz system  
= 020: Parameters restored to 60Hz system**

1. When F\_25 is set to 010, all parameters are restored to factory settings for 50Hz operation. The settings of F\_05 = 1 and F\_06 = 50. F\_25 is restored to 000 after the reset process is complete.

2. When F\_25 is set to 020, all parameters are restored to factory settings for 60Hz operation. The settings of F\_05 = 4 and F\_06 = 60. F\_25 is restored to 000 after the reset process is complete.

### 3.3 MALFUNCTION INDICATIONS AND COUNTERMEASURES

#### 1. Manual Reset Inoperative Malfunctions

INDICATION	CONTENT	POSSIBLE CAUSE	COUNTERMEASURE
<b>CPF</b>	Program error	Outside noise interference	Place an RC surge protector in parallel with the noise generating magnetic contact
<b>EPR</b>	EEPROM error	EEPROM defective	Replace EEPROM
<b>OV</b>	Voltage too high when not operating	1. Power source voltage too high 2. Detection circuitry defective	1. Examine the line supply 2. Return the controller for repair
<b>LV</b>	Voltage too low when not operating	1. Power source voltage too low 2. Detection circuitry defective	1. Examining the line supply 2. Return the controller for repair
<b>OH</b>	Controller over heats when not operating	1. Detection circuit defective 2. Environment overheat or poor ventilation	1. Return the controller for repair 2. Improve ventilation

#### 2. Manual Reset Operative Malfunctions (Auto-Reset Inoperative)

INDICATION	CONTENT	POSSIBLE CAUSE	COUNTERMEASURE
<b>OC</b>	Over-current at stop condition	Detection circuit malfunction	Return the controller for repair
<b>OL1</b>	Motor overload	1. Excessive load 2. Incorrect V/F model setting 3. Incorrect F_18 setting	1. Increase capacity of motor 2. Adjust to use a proper V/F curve setting 3. Adjust F_18 according to instructions
<b>OL2</b>	Controller overload	1. Excessive load 2. Incorrect V/F model setting	1. Increase capacity of controller 2. Adjust to use a proper V/F curve setting

### 3.Manual Reset and Auto-Reset Operative Malfunction

INDICATION	CONTENT	POSSIBLE CAUSE	COUNTERMEASURE
<b>OCS</b>	Transient over-current when starting	<ol style="list-style-type: none"> <li>1. Motor shorted to external casing</li> <li>2. Motor connection wire shorted or grounded</li> <li>3. Transistor module damaged</li> </ol>	<ol style="list-style-type: none"> <li>1. Examine the motor</li> <li>2. Examine the wiring</li> <li>3. Replace the transistor module</li> </ol>
<b>OCA</b>	Over-current at acceleration	<ol style="list-style-type: none"> <li>1. Acceleration time setting too short</li> <li>2. Incorrect V/F feature selection</li> <li>3. Motor capacity exceeds controller capacity</li> </ol>	<ol style="list-style-type: none"> <li>1. Adjust acceleration time to a longer setting</li> <li>2. Adjust to a proper V/F curve</li> <li>3. Increase controller capacity</li> </ol>
<b>OCC</b>	Over-current at steady speed	<ol style="list-style-type: none"> <li>1. Oscillating load</li> <li>2. Fluctuating line supply</li> </ol>	<ol style="list-style-type: none"> <li>1. Examining the load configuration</li> <li>2. Install an inductor on the line supply input</li> </ol>
<b>OCd</b>	Over-current at deceleration	Deceleration setting too short	Adjust deceleration time to a longer setting
<b>OCb</b>	Over-current at braking	DC braking frequency, braking voltage, or braking time setting too long	Reduce settings of F_15, F_16, or F_17
<b>OVC</b>	Over-voltage at operation/ deceleration	<ol style="list-style-type: none"> <li>1. Deceleration time setting too short or load inertia too large</li> <li>2. Line supply voltage fluctuation too large</li> </ol>	<ol style="list-style-type: none"> <li>1. Adjust for a longer deceleration time</li> <li>2. Install an inductor on the line supply input</li> </ol>
<b>LVC</b>	Insufficient voltage level at operation	<ol style="list-style-type: none"> <li>1. Line supply voltage too low</li> <li>2. Line supply voltage variation too large</li> </ol>	<ol style="list-style-type: none"> <li>1. Improve line supply quality</li> <li>2. Adjust for a longer acceleration time</li> <li>3. Increase capacity of controller</li> <li>4. Install a reactor on the line supply input</li> </ol>
<b>OHC</b>	Heat-sink over heated at operation	<ol style="list-style-type: none"> <li>1. Excessive load</li> <li>2. Ambient temperature too high or poor ventilation</li> </ol>	<ol style="list-style-type: none"> <li>1. Reduce the load</li> <li>2. Increase capacity of controller</li> <li>3. Improve ventilation</li> </ol>

## Special Condition Description

INDICATION	CONTENT	DESCRIPTION
SP0	Zero speed stopping	When F_11 = 0, F_7 = 0 and frequency setting < 1 Hz When F_11 = 1, F_7 < (F_6/100), and frequency setting < (F_6/100)
SP1	Fail to start directly	1. If the controller is set to external operation (F_10 = 1) and direct start is disabled (F_28 = 1), the controller cannot be started, and will flash SP1 when operation switch turned to ON after applying power (see descriptions of F_28). 2. Direct start is possible when F_28 = 0.
SP2	Keypad emergency stop	The controller is set to external operation (F_10=1). If the STOP key on the keypad is pressed at the middle of operation, the drive stops according to the setting in F_14 and flashes SP2 after stop. The RUN switch must be turned OFF, then ON to restart the drive.
E.S.	External emergency stop	When the external emergency stop signal is activated through the multifunction input terminal, the motor decelerates and stops. Controller flashes E.S. after stop. (Refer to instructions for F_19 for details.)
b.b.	External BASE BLOCK	When the external BASE BLOCK signal is activated through the multifunction terminal, the controller shuts down immediately and flashes b.b. (Refer to instructions for F_19 for details.)

## Keypad Operation Error Instructions

INDICATION	CONTENT	POSSIBLE CAUSE	COUNTERMEASURE
LOC	Motor direction locked	1. Attempt to reverse direction when F_22 = 1 2. Attempt to set F_22 to 1 when F_04 = 1	1. Set F_22 to 0 2. Set F_04 to 0
Er1	Keypad operation error	1. Press▲ or ▼ keys when F_11 = 1 or under SP1 operation 2. Attempt to modify F_29 3. Attempt to modify parameter that is not allowed to be modified during operation (refer to parameter list)	1. Use▲ or ▼ keys to adjust frequency setting only when F_11 = 0 2. Do not modify F_29 3. Modify parameter in stop mode
Er2	Parameter setting error	$F_6 \leq F_7$	$F_6 > F_7$

### 3.4 GENERAL MALFUNCTION EXAMINATION METHOD

ABNORMALITY	CHECK POINT	COUNTERMEASURE
<b>Motor inoperative</b>	Is line voltage applied to L1, L2 or L3 terminals (is the charging indicator illuminated)?	<ul style="list-style-type: none"> <li>● Check if the power source is on.</li> <li>● Turn power source OFF and then ON again.</li> <li>● Reconfirm the line voltage level.</li> </ul>
	Is there voltage at output terminals T1, T2 and T3?	<ul style="list-style-type: none"> <li>● Turn power source OFF and then ON again.</li> </ul>
	Is the motor wired correctly?	<ul style="list-style-type: none"> <li>● Check motor wiring.</li> </ul>
	Are there any abnormal controller conditions?	<ul style="list-style-type: none"> <li>● Refer to malfunction handling instructions to examine and correct wiring.</li> </ul>
	Is the forward or reverse instruction loaded?	
<b>Motor inoperative</b>	Is the analog frequency setting loaded?	<ul style="list-style-type: none"> <li>● Check if the wiring for the analog frequency input signal is correct.</li> </ul>
	Is the operation mode setting correct?	<ul style="list-style-type: none"> <li>● Check if the frequency input setting voltage is correct.</li> </ul>
<b>Motor operates in opposite direction</b>	Is the wiring on output terminals T1, T2 and T3 correct?	<ul style="list-style-type: none"> <li>● Operate by digital?</li> </ul>
	Is the wiring for the forward and reverse signals correct?	<ul style="list-style-type: none"> <li>● Wiring should be in accordance with the U, V, W terminals of the motor.</li> </ul>
<b>Motor operation speed fixed</b>	Is the wiring for the analog frequency input correct?	<ul style="list-style-type: none"> <li>● Examine the wiring and correct it.</li> </ul>
	Is the operation mode setting correct?	<ul style="list-style-type: none"> <li>● Examine the wiring and correct it.</li> </ul>
	Is the loading excessive?	<ul style="list-style-type: none"> <li>● Reduce the load.</li> </ul>
<b>Motor operates at speeds too high or too low</b>	Is the specification of the motor (poles, voltage) correct?	<ul style="list-style-type: none"> <li>● Check motor specification.</li> </ul>
	Is the gear ratio correct?	<ul style="list-style-type: none"> <li>● Check gear ratio.</li> </ul>
	Is the highest output frequency setting correct?	<ul style="list-style-type: none"> <li>● Check highest output frequency.</li> </ul>
	Is the motor voltage too low?	<ul style="list-style-type: none"> <li>● Check motor voltage.</li> </ul>
<b>Abnormal speed variation at operation</b>	Is the loading excessive?	<ul style="list-style-type: none"> <li>● Increase controller and motor capacity.</li> </ul>
	Is the loading variation too large?	<ul style="list-style-type: none"> <li>● Reduce loading variation.</li> </ul>
	Is the input power source steady and stable?	<ul style="list-style-type: none"> <li>● Install an AC reactor on the line supply.</li> </ul>

**ACE10UG  
August 2003**

**14 Hayward Street  
Quincy, MA 02190  
(617) 328-3300  
Fax: (617) 479-6238**