



Boston Gear
14 Hayward Street
Quincy, MA 02171
tel 617.328.3300
fax 617.479.6238

ACE10TM
08/03

*** ACE 10 SERIES ***
ADJUSTABLE FREQUENCY
AC MOTOR CONTROLLERS
TECHNICAL MANUAL
(1/4 - 3 HP)

MODEL NO. _____

SERIAL NO. _____

INPUT SUPPLY _____ VAC, 50/60 Hz

HORSEPOWER _____

TABLE OF CONTENTS

Foreword	3
1. Safety precautions	3
2. Examination before installation	4
1. Safety Precautions	
1.1 Precautions for operation	5
1.2 Precautions of operation environment	8
2. Hardware Instructions and Installation	
2.1 Operation environment	9
2.2 Model No. identification	10
2.3 Specifications	11
2.4 Wiring diagram	17
2.5 Dimensions & location of terminal block	21
2.6 Mounting instructions	23
3. Software Index	
3.1 Keypad operating instructions	26
3.2 Parameters list	27
3.3 Parameter function description	28
3.4 Malfunction indications and countermeasures	40
3.5 General malfunction examination method	43
4. Troubleshooting Procedure	
4.1 Flow chart	44
4.2 Routine and periodic examination	51
4.3 Maintenance and examination	52
4.4 Voltage & current measurements	53
4.5 EMI filter (Class B) specification	54
4.6 DIN Rail specification	54
4.7 Specification of braking resistor and input reactor	54
4.8 Specification of braking resistor	55
4.9 Parameters table	56

FOREWORD

To fully use all functions of this AC Drive, and to ensure the safety of its users, please read through this technical manual in detail. If you have any further questions, please feel free to contact your local distributor or regional representative.

1. SAFETY PRECAUTIONS

The AC Drive is a power electronic device. For safety reasons, please read carefully those paragraphs with "WARNING" and "CAUTION" symbols. They are important safety precautions to be aware of while transporting, installing, operating or examining the AC drive. Please follow these precautions to ensure your safety.

 **WARNING** Personal injury may occur from improper operation.

 **CAUTION** The AC Drive or mechanical system may be damaged by improper operation.

WARNING

- Do not touch the PCB or components on the PCB after turning off the power before the charging indicator is turned off.
- Do not attempt to wire circuitry while power is on. Do not attempt to examine components and signals on the PCB while the drive is operating.
- Do not attempt to disassemble or modify internal circuitry, wiring, or components of the controller.
- The grounding terminal of the controller must be grounded properly to 200V class type III standard.
- This is a product of the restricted sales distribution class according to EN61800-3.

In a domestic environment, this product may cause radio interference in which case the user may be required to take adequate measures.

CAUTION

- Do not attempt to perform dielectric strength test to internal controller components. There are sensitive semiconductor devices vulnerable to high voltage in the controller.
- Do not connect the output terminals: T1 (U), T2 (V), and T3 (W) to AC power.
- The CMOS IC on the primary PCB of the controller is vulnerable to static electrical charges. Do not contact the primary PCB of the controller.

2. EXAMINATION BEFORE INSTALLATION

Every controller has been fully tested and examined before shipment. Please perform the following examination procedure after unpacking your AC controller.

- Check if the model number of the AC controller matches the model number of the AC controller that you ordered.
- Check whether any damage occurred to the AC controller during shipment. Do not connect the AC controller to a power supply if there is any sign of damage.

Report any abnormalities to your sales representative.

1. SAFETY PRECAUTIONS

1.1 PRECAUTIONS FOR OPERATION

Before turning ON power

⚠ CAUTION

Choose the appropriate power source with the correct voltage for the input power to the AC controller.

⚠ WARNING

Special care must be taken when wiring the primary circuitry panel. The input power source must be connected to the L1, L2 or L3 terminals, and must not be mistakenly connected to the T1, T2 or T3 output terminals. This may damage the controller when power is turned on.

⚠ CAUTION

- Do not attempt to carry the controller by the front of the cover. Securely hold the controller by the heat-sink mounting chassis to prevent the controller from falling, as this may cause personal injury or damage to the controller.
- Install the controller onto a firm metal base plate or other non-flammable type material. Do not install the controller onto or nearby any flammable material.
- An additional cooling fan may be needed if several controllers are installed onto one control panel. The temperature inside an enclosed panel should be below 40 degrees C (104 degrees F) to avoid overheating.
- Turn off the power (line) supply before removing or performing any work on any panel. Carry out installation procedures according to instructions given in order to avoid an operation malfunction.
- The AC controller is for use on a circuit capable of delivering not more than 5000 RMS symmetrical amperes.
- The controller is not provided with overspeed protection.
- The controller is only intended for use in a pollution degree 2 environment or equivalent.

When power is applied:

! WARNING

- Do not install or remove input or output controller connections when the power (line) supply is turned on. Otherwise, the controller may be damaged due to the surge peak caused by the application or removal of power.
- When momentary power loss is longer than 2 seconds (the larger the horsepower, the the longer the time), the controller does not have enough storage power to retain control. Therefore, when power is reapplied, the operation of the controller is based on the setup of F_10 and the condition of an external switch (FWD/REV button). This is considered to be a restart in the following paragraphs.
- When the momentary power loss is short, the controller still has enough storage power to retain control. Therefore, when power is reapplied, the controller will automatically start operation again, depending on the setup of F_23.

When the controller restarts, the operation is based on the setup of F_10, and the condition of an external switch (FWD/REV button). The restart operation is irrelevant with F_23/F_24.

(1) When F_10 = 0, the controller will not start after restart.

(2) When F_10 = 1 and the external switch (FWD/REV button) is OFF, the controller will not start after a restart command.

(3) When F_10 = 1 and the external switch (FWD/REV button) is ON, the controller will start automatically after a restart command. For safety reasons, turn off the external switch (FWD/REV button) after a power loss to avoid possible damage to the machine and personal injury after sudden regeneration of power.

During Operation:

! WARNING

Do not use a separate device to switch the motor ON or OFF during operation. Otherwise, the controller may experience an over-current breakdown.

! WARNING

- Do not remove the controller front cover when the power is ON to avoid personal injury caused by electrical shock.
- When the automatic restart function is enabled, the motor and machinery will restart automatically.

▲ CAUTION

- Do not touch the heat-sink base during operation.
- The controller can be easily operated from a low-speed to high-speed range. Reconfirm the operating range of the motor and the machinery you are controlling.
- Do not examine the signals on the PCB of the controller during operation.
- All controllers are properly adjusted and set before delivery.

▲ CAUTION

Do not disassemble or examine the controller before ensuring that the power source is OFF and the Power LED is not lit.

When performing an examination or maintenance:

▲ CAUTION

The controller environment should be within: -10°C ~ +40°C (14°F ~ 104°F), with humidity under 95% RH without condensing.

▲ CAUTION

After the removing the shield sticker, the environment should be within: -10°C ~ +50°C (14°F ~ 122°F) with humidity under 95% RH without condensing. The controller should be free from water dripping and metal dust.

1.2 PRECAUTIONS OF OPERATION ENVIRONMENT

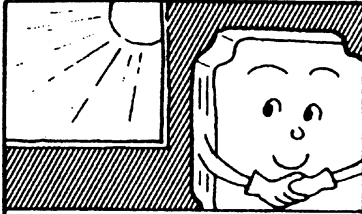

Avoid any direct sunlight

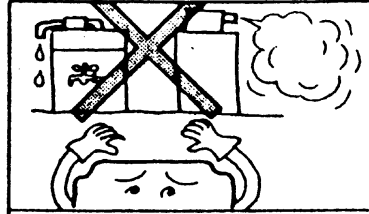

Keep away from corrosive gas and liquid

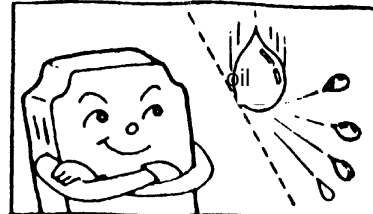

Keep away from oil, grease and gas

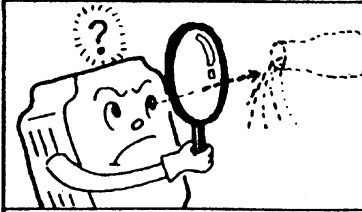

Keep away from salty environments

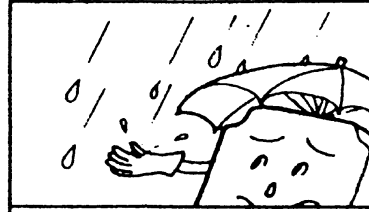

Keep away from rain or where dripping water may get into the controller

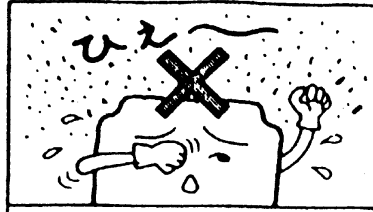

Avoid metal dust and dusty environments

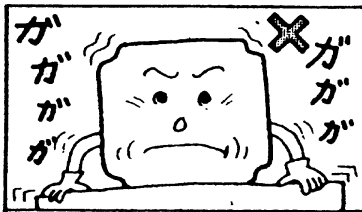

Avoid massive vibration

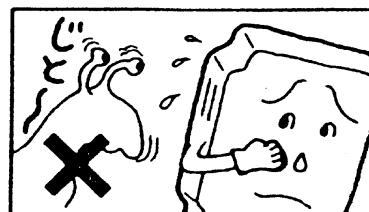

Avoid excessive direct heat

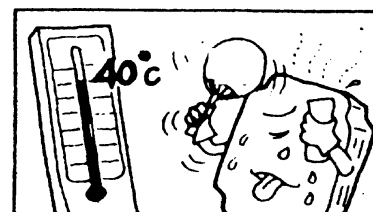

Avoid environments where temperatures are too high

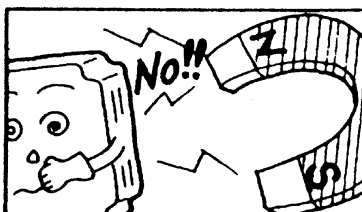

Keep away from high electrical-magnetic waves

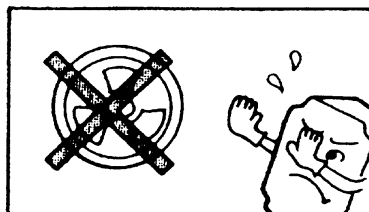

Keep away from radioactive matter

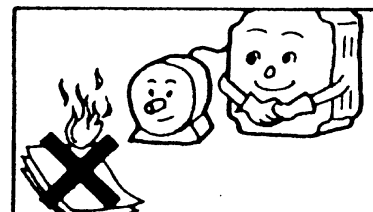

Keep away from flammable material

2. HARDWARE INSTRUCTIONS AND INSTALLATION

2.1 OPERATION ENVIRONMENT

The installation site of the controller is very important. It relates directly to the functionality and the life span of your controller. Carefully choose the installation site to meet the following requirements:

- Mount the controller vertically
- Environment temperature: $-10^{\circ}\text{C} \sim +40^{\circ}\text{C}$ ($14^{\circ}\text{F} \sim 104^{\circ}\text{F}$) (w/o shield sticker: $-10^{\circ}\text{C} \sim +50^{\circ}\text{C}$ ($14^{\circ}\text{F} \sim 122^{\circ}\text{F}$))
- Avoid placing the controller close to any heating equipment
- Avoid water dripping and humid environment
- Avoid direct sunlight
- Avoid oil and salty corrosive gas
- Avoid contacting corrosive liquid and gas
- Prevent foreign dust, flocks, and metal scraps from entering the controller interior
- Avoid electrical-magnetic interference (soldering or power machinery)
- Avoid vibration. If vibration cannot be avoided, an anti-vibration mounting device should be installed to reduce vibration.
- If the controller is installed on an enclosed control panel, remove the shield sticker located at the top of the controller. This will allow additional airflow and cooling.

External Fan Placement needs to be over the top of the controller.

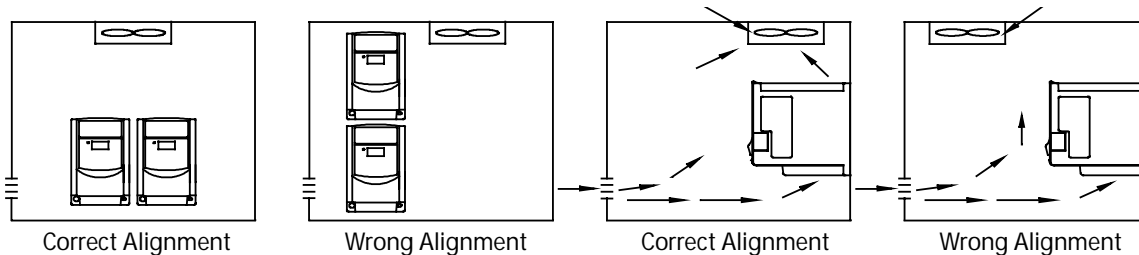

- For proper Installation of the controller, place the front of the controller facing front and the top of the controller in the up direction for better heat dissipation.
- Installation must be compliant with the following requirements:

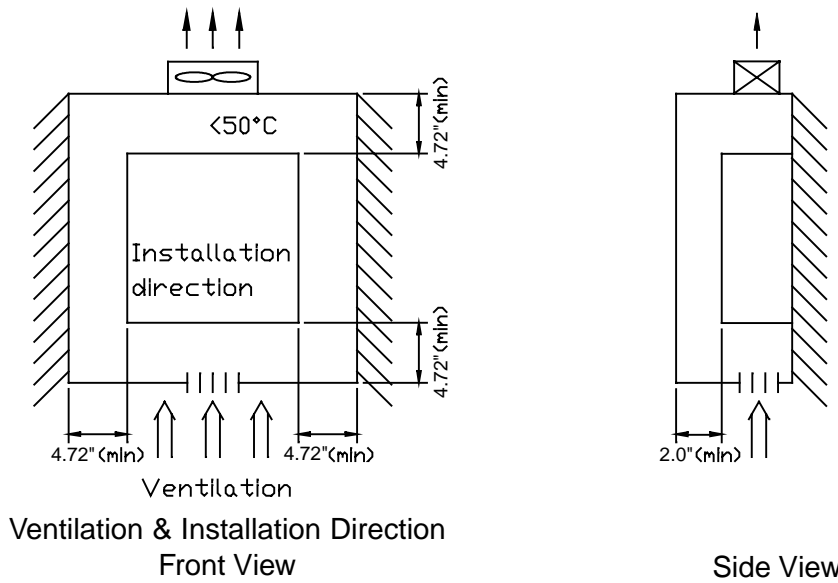

Note: Maximum temperature in the enclosure: 50°C (122°F)

2.2 MODEL NO. IDENTIFICATION

CATALOG NUMBER	ITEM CODE	TYPE	HP RATING	VOLTAGE	PHASE	AMPS
ACE101V1P0002C	43285	Chassis	1/4	115	1	1.4
ACE101V1P0005C	43286		1/2			2.3
ACE101V1P0010C	43287		1			4.2
ACE102V1P0002C	43288		1/4	230	1	1.4
ACE102V1P0005C	43289		1/2			2.3
ACE102V1P0010C	43290		1			4.2
ACE102V3P0020C	43291		2	460	3	7.5
ACE102V3P0030C	43292		3			10.5
ACE104V3P0010C	43293		1			2.3
ACE104V3P0020C	43294		2	3.8		
ACE104V3P0030C	43295		3	5.2		
ACE101V1P0002N4	43296		NEMA 4	1/4	115	1
ACE101V1P0005N4	43297	1/2		2.3		
ACE101V1P0010N4	43298	1		4.2		
ACE102V1P0002N4	43299	1/4		230	1	1.4
ACE102V1P0005N4	43300	1/2				2.3
ACE102V1P0010N4	43301	1				4.2
ACE102V3P0020N4	43302	2		460	3	7.5
ACE102V3P0030N4	43303	3				10.5
ACE104V3P0010N4	43304	1				2.3
ACE104V3P0020N4	43305	2		3.8		
ACE104V3P0030N4	43306	3		5.2		

a. Can be operated at single phase without derating.

2.3 SPECIFICATIONS

2.3.1 Basic Specifications

Model	Chassis	
	ACE101V1P0002C	ACE101V1P0005C
Suitable Motor Power Rating (kW)		
Motor (HP)	1/4	1/2
Output Current (A)	1.4	2.3
Capacity (KVA)	0.53	0.88
Weight (lbs)	1.7	1.7
Chassis	NEMA 4	
Input Voltage, Maximum	Single Phase 100-120 VAC (+10%, -15%), 50/60 Hz (+/-5%)	
Output Voltage, Maximum	Three Phase 200-240 VAC (Proportional to input voltage)	
Dimensions W*H*D (Inches)	2.83 x 5.16 x 4.65	
EMC Specification	5.54 x 8.49 x 7.19 Without Filter	

Model	Chassis	
	ACE102V1P0002C	ACE102V1P0005C
Suitable Motor Power Rating (kW)		
Motor (HP)	0.2	0.4
Output Current (A)	1/4	1/2
Capacity (KVA)	0.53	0.88
Weight (lbs)	1.7	1.7
Chassis	NEMA 4	
Input Voltage, Maximum	Single Phase 200-240 VAC (+10%, -15%), 50/60 Hz (+/-5%)	
Output Voltage, Maximum	Three Phase 200-240 VAC (Proportional to input voltage)	
Dimensions W*H*D (Inches)	2.83 x 5.16 x 4.65	
EMC Specification	5.54 x 8.49 x 7.19 Class A (Single phase filter built in)	

Model	Chassis	
	ACE104V3P0010C	ACE104V3P0020C
Suitable Motor Power Rating (kW)		
Motor (HP)	0.75	1.5
Output Current (A)	1	2
Capacity (KVA)	1.7	2.9
Weight (lbs)	3.1	3.1
Chassis	NEMA 4	
Input Voltage, Maximum	Three Phase 380-480 VAC (+10%, -15%), 50/60 Hz (+/-5%)	
Output Voltage, Maximum	Three Phase 380-480 VAC (Proportional to input voltage)	
Dimensions W*H*D (Inches)	4.65 x 5.63 x 6.77	
EMC Specification	9.13 x 11.61 x 8.32 Class A (Three phase filter built in)	

2.3.2 Functional Specifications

Item		Specification
Input Signal Type		PNP type (SOURCE) input (External 24 VDC input is allowed)
Control Method		Sinusoidal wave PWM control
Frequency Control	Frequency Range	1 - 200 Hz
	Resolution Setting	Digital: 0.1 Hz (1 - 99.9 Hz); 1 Hz (100 - 200 Hz) Analog: 1 Hz / 60 Hz
	Keypad Setting	Direct setup by ▲▼ buttons
	External Signal Setting	0 - 10V, 4 - 20mA, 0 - 20mA
	Other Function	Frequency upper and lower limit
General Control	Carrier Frequency	4 - 16 KHz
	Accel/Decel Time	0.1 - 999 seconds
	V/F Pattern	6 patterns
	Torque control	Torque boost level adjustable (manual torque boost)
	Multi-functional Input	2 point, to be used as multi-speed 1(Sp. 1) / multi-speed 2(Sp. 2) / Jog / External emergency stop / External bb / Reset
	Multi-functional Output	1a relay terminal, to be set up as Fault / Running / Frequency
	Braking Torque	About 20%. 20 - 100% with built -in braking transistor
Other Function	Decelerate or free run stop, Auto reset, DC braking frequency / Voltage / Time can be set up by constants	
Display		Three LED's display frequency / drive parameter / fault record / program version
Operating Temperature		-10 - +40° C (14 - 104° F) (without shield sticker: -10 - +50° C (14 - 122° F))
Humidity		0 - 95% RH non-condensing
Vibration		Under 1G (9.8 m/s ²)
EMC Specification		EN5008-1, EN5008-2, EN50082-1, EN50082-2, EN50178
UL		UL508C
Protection Function	Overload	150% for 1 minute
	Over Voltage	DC voltage > 410V(100/200 series); DC voltage > 800V(400 series)
	Under Voltage	DC voltage < 200V(100/200 series); DC voltage < 400V(400 series)
	Momentary Power Loss	0 - 2 seconds: The drive can be restarted using speed search feature.
	Stall Prevention	During Acceleration / Deceleration / Constant speed
	Output Short-circuit	Electronic circuitry protection
	Grounding Fault	Electronic circuitry protection
Other Function	Heat sink overheat protection, Current limit	
Installation		Mounting screw or DIN rail (option)

2.3.3 Suitable Optional and Wiring Specifications

Molded-Case Circuit Breaker / Magnetic Contact

● **Warranty does not apply to damage caused by the following situations:**

- (1) Damage to the controller caused by the lack of appropriate molded-case circuit breaker or when a circuit breaker with too large of capacity is installed between the power supply and the controller.
- (2) Damage to the controller caused by a magnetic contact, phase advancing capacitor, or surge-protector installed between the controller and the motor.

Controller Rating	1.4/2.3A, 115/230V	4.2/7.5A, 115/230V	10.5A, 230V	2.3/3.8/5.2A, 460V
Molded-case circuit breaker	15A	20A	30A	15A
Primary Circuit Terminal (TM1) L1 L2 L3* T1 T2 T3 * Terminal L3 is on three phase controllers only.	Wire dimension (#14AWG) 2.0mm ² Terminal screw M3	Wire dimension (#14AWG) 2.0m m ² Terminal screw M3/M4	Wire dimension 3.5mm ² Terminal screw M4	Wire dimension 3.5mm ² Terminal screw M4
Signal Terminal (TM2) 1~11	Wire dimension 0.75mm ² (#18 AWG), Terminal screw M3			

Use copper conductors only. Size field wiring based on 80 degrees C wire only.

- Use a three-phase squirrel-cage induction motor with appropriate rating.
- If the controller is used to drive more than one motor, the total motor current must be less than the controller current rating. Additional thermal overload relays must be installed in series with each motor. Use the Fn_18 at 1.0 times the rated value specified on the motor nameplate at 50Hz, 1.1 times the rated value specified on the motor nameplate at 60Hz.
- Do not install phase advancing capacitors, LC, or RC components between the controller and motor.

2.3.4 Application and precautions of peripherals

From the power source (AC line supply):

- Be sure the power source is rated correctly to prevent damaging the controller.
- A power disconnect or circuit breaker must be installed between the AC power supply and the controller.

Molded-case circuit breaker:

- Use a correctly sized circuit breaker to protect the controller.

- Do not use the circuit breaker to switch power ON or OFF to the controller. The circuit breaker should be used only to provide protection.

Leakage circuit breaker:

- An earth leakage circuit breaker should be added to prevent false operation cause by leakage current, and to ensure personal safety.

Magnetic contactor:

- A magnetic contactor can usually be omitted. However, to utilize external control, automatic restart, or braking the controller, a magnetic contactor must be added at the primary side.
- Do not use a magnetic contactor to switch power ON or OFF to the controller.

Power improvement AC reactor:

- If a large capacity power source is applied (over 600KVA), an additional AC reactor may be added to improve power factor.

Controller:

- The power supply input terminals (L1, L2 and L3) are not sensitive to phase sequence. They can be arbitrarily connected. Also, their connections may be interchanged.
- Output terminals T1, T2, and T3 should be connected to motor terminals U, V, and W, respectively. If the motor turns in the opposite direction of the controller command, simply exchanging two of the three motor connections to correct this problem.
- Output terminals T1, T2, and T3 must not be connected to a power source. Otherwise, the controller may become damaged.

- Properly ground the grounding terminal in compliance to 200V class type three grounding. (The 400V class type is special grounding.)

External wiring must comply with the following requirements.
Be sure all wiring is correct.

(Do not use a control circuitry buzzer to check the wiring.)

EMI connections:

It is very important that the connections between the controller, the shielded motor cable, and the EMI filters are tested as follows:

- Use a metal grounding plate and place the controller and the EMI filter on the plate.
- Use a shielded motor cable with 4 connectors (U, V, W, & Earth). Don't use the shielding as safety earth (the shield is high frequency earth).
- Remove any paint around the two metal coupling nut holes so that the metal coupling nuts (and the shielding) make contact with the controller and the motor.
- Don't solder a conductor to the shielding.
- Use a metal clamp to connect the shielding from the motor cable to the metal grounding plate. This ensures that there is a good high frequency earth connection between the controller, grounding plate, and EMI filter.
- Keep the distance between the controller and EMI filter as short as possible (< 11.8"). If the distance is longer, use a shielded cable with a metal coupling nut and a metal clamp to connect the shielded cable to the controller and metal grounding plate.
- The only earth connection between the LISN and the test plate should be via the EMI filter.
- Use a motor which equals or is less than the power rating of the controller.

Class B:

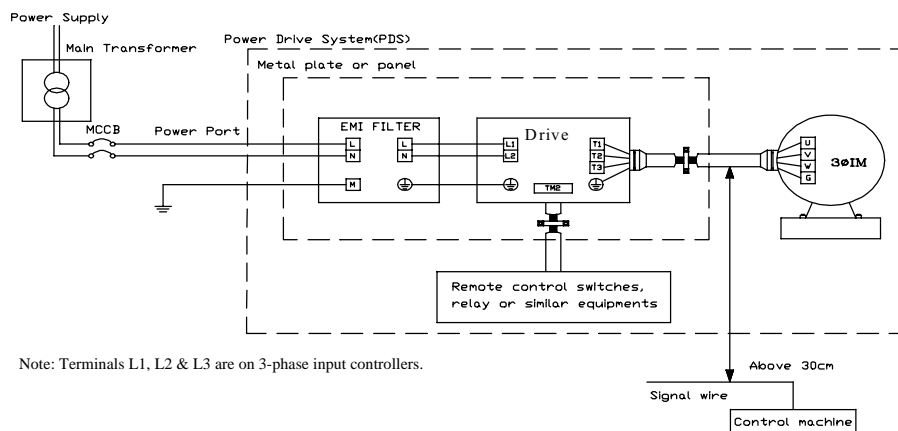

Class A:

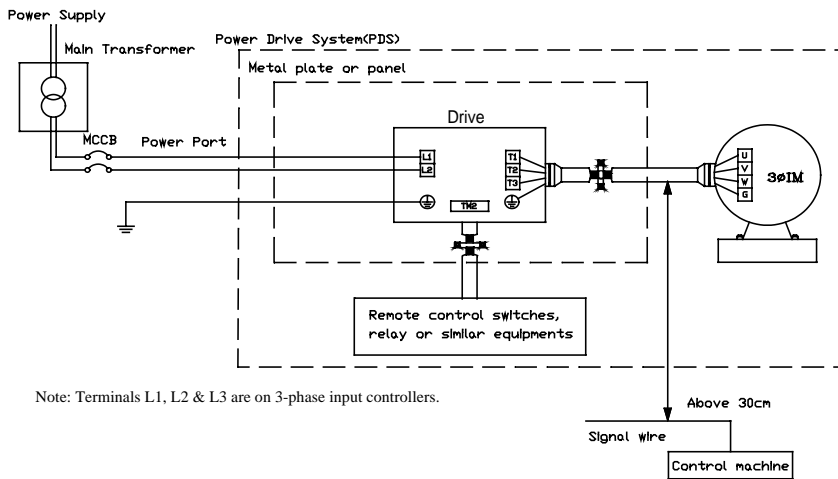

- Installing a noise filter onto the output side of the primary circuitry can suppress conducting noise.
- When the distance between the controller and motor is longer than 330 ft (100 m), cable wire should be carefully chosen to reduce the wiring resistance to less than 3%, and the voltage drop $(V) = \sqrt{3} \times \text{Wire resistance (}\Omega/\text{km)} \times \text{wire length (m)} \times \text{current} \times 10^{-3}$.
- Control circuitry wiring must be separately terminated and kept away from the primary power circuitry and other high-voltage or large-current power lines to avoid noise interference.
- To reduce noise interference and avoid possible operation problems, shielded twisted pair cable should be used to wire the control circuitry. Refer to the following diagram. Connect the shielding wire to the grounding terminal. Only connect one end of the shield.

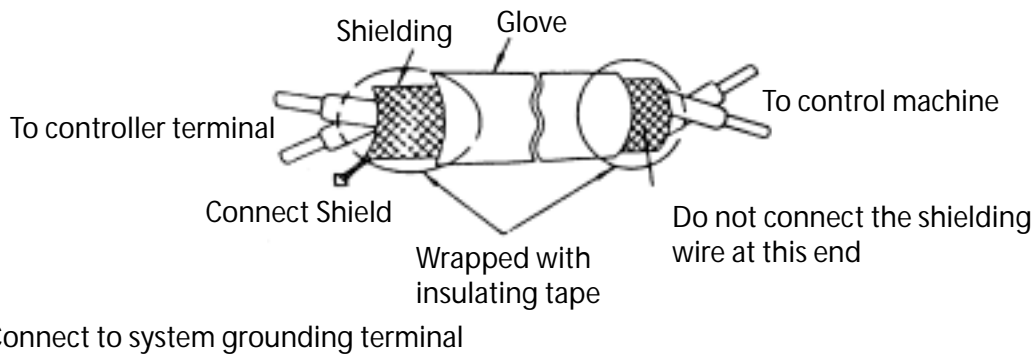

Wiring distance must be under 164 ft (50 m).

- The grounding terminal of the controller must be correctly grounded in compliance with 200V class type three grounding.
- The grounding wire should be wired in accordance to electrical equipment (AWG) with the length of the grounding wire as short as possible.

- The grounding wire of the controller must not be grounded together with other large current loads (such as soldering machines or large current motors). They should be grounded separately.

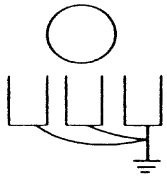

(a) good

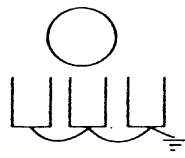

(b) good

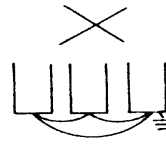

(c) not good

2.4 WIRING DIAGRAMS

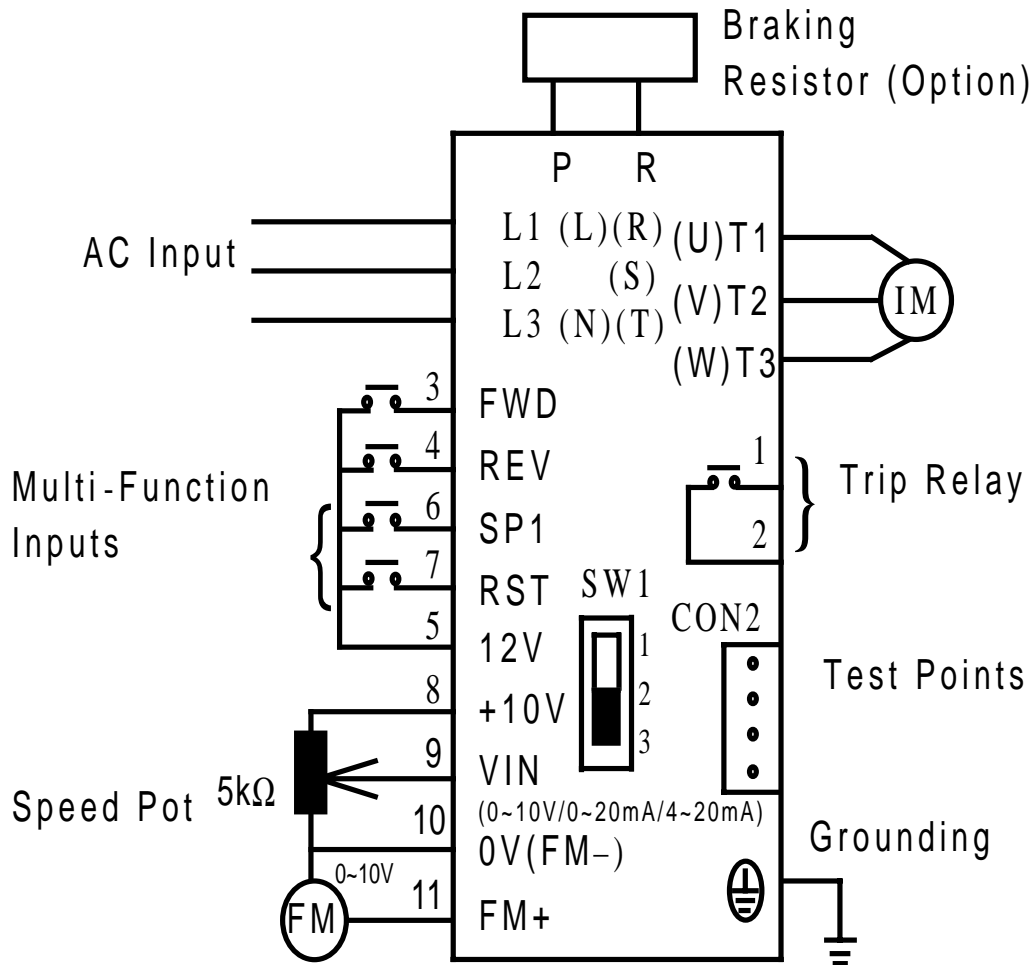

- Grounding circuitry must not be formed when grounding several controllers together.

Use appropriate wire with correct diameter for primary power circuitry and control circuitry in accordance with electrical regulations.

External 24V supply

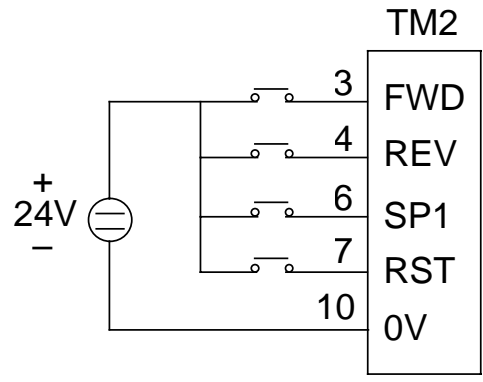

PARAMETER SETTING	SETTINGS	
	EXTERNAL SPEED CONTROL	KEYPAD SPEED CONTROL
F03 OPERATION MODE	0	0
F10 START STOP CONTROL	1	1
F11 FREQUENCY CONTROL	1	0

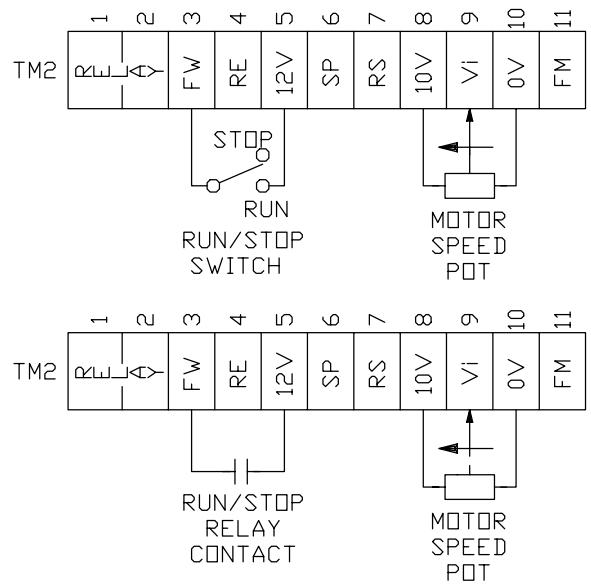

FIGURE 1.

RUN STOP OPERATION BY SWITCH OR RELAY CONTACT WITH SPEED CONTROL BY SPEED POT OR KEYPAD

PARAMETER SETTING	SETTINGS	
	EXTERNAL SPEED CONTROL	KEYPAD SPEED CONTROL
F03 OPERATION MODE	0	0
F10 START STOP CONTROL	1	1
F11 FREQUENCY CONTROL	1	0

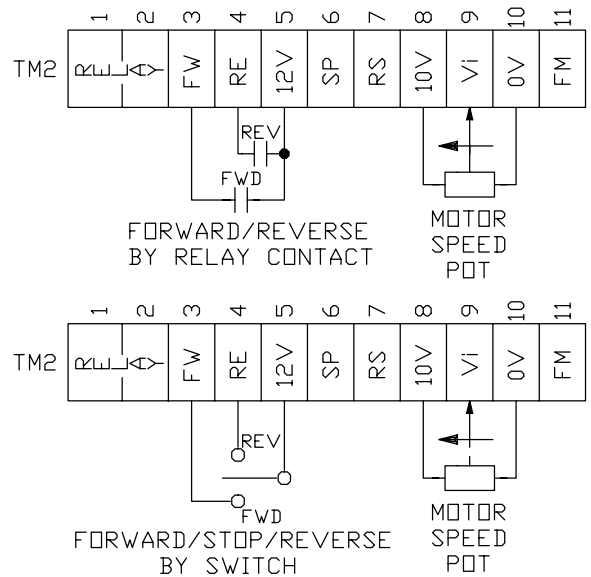

FIGURE 2.

FORWARD STOP REVERSE OPERATION BY SWITCH OR RELAY CONTACT WITH SPEED CONTROL BY SPEED POT OR KEYPAD

Controller Terminal Descriptions

Primary Circuitry Terminal Block (TM1) description

Terminal Symbol	Function Description
L1/L (R)	Primary power source (line voltage) input to the controller
L2 (S)	
L3/N (T)	
P	External braking resistor terminal (Only for - 2 & 3HP, 230V & 1 - 3HP, 460V)
R	
T1 (U)	Controller output to the motor
T2 (V)	
T3 (W)	

Tightening torque for TM1 is 1 LB-FT or 12 LB-IN (1/4HP - 1/2HP, 115V & 1/4 - 1HP, 230V).

Tightening torque for TM1 is 1.3 LB-FT or 16 LB-IN (2 - 3HP, 230V & 1 - 3HP, 460V).

* Wire voltage rating must be a minimum of 300V(200V series) / 600V(400V series).

Control Circuitry Terminal Block (TM2) description

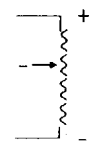
Terminal Symbol	Function Description		
1	TRIP	Fault relay output terminal. Multifunction output terminal (refer to F_21) Connection point rated 250VAC @ 1A (30VDC @ 1A)	
2	RELAY		
3	FWD (FW)	Operation control terminals (refer to F_03)	
4	REV (RE)		
5	+ 12V(12)	Common point of terminals 3, 4, 6 & 7	
6	SP1(SP)	Multifunction input terminals (refer to F_19)	
7	RESET(RS)		
8		+10V	Power terminal for potentiometer (Pin 3)
9		Analog input wire Wiper	Analog frequency signal input terminal (Pin 2 of potentiometer or positive terminal of 0~10V / 4~20mA / 0~20mA)
10	0V(FM -)	Analog common point	Analog signal common point (Pin 1 of potentiometer or negative terminal of 0~10V / 4~20mA / 0~20mA)
11	FM+	Analog output positive connection point	Analog frequency signal output terminal Output terminal signal is 0 ~ 10VDC/Fn6

Tightening torque for TM2 is 0.42 LB-FT or 5.03 LB-IN.

* Wire voltage rating must be a minimum of 300V.

* Control wiring should not be run in the same conduit or raceway with power or motor wiring.

* Single Input and Output Terminals (TM2): Ratings are all Class 2.

SW1 function description

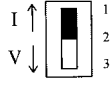
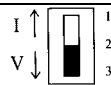
SWITCH 1	External signal type
	0~20mA analog signal (When F_11 is set to 1)
	4~20mA analog signal (When F_11 is set to 2)
	0~10 VDC analog signal (When F_11 is set to 1)

2.5 DIMENSIONS & LOCATION OF TERMINAL BLOCK

1/4-1HP, 115/230V:

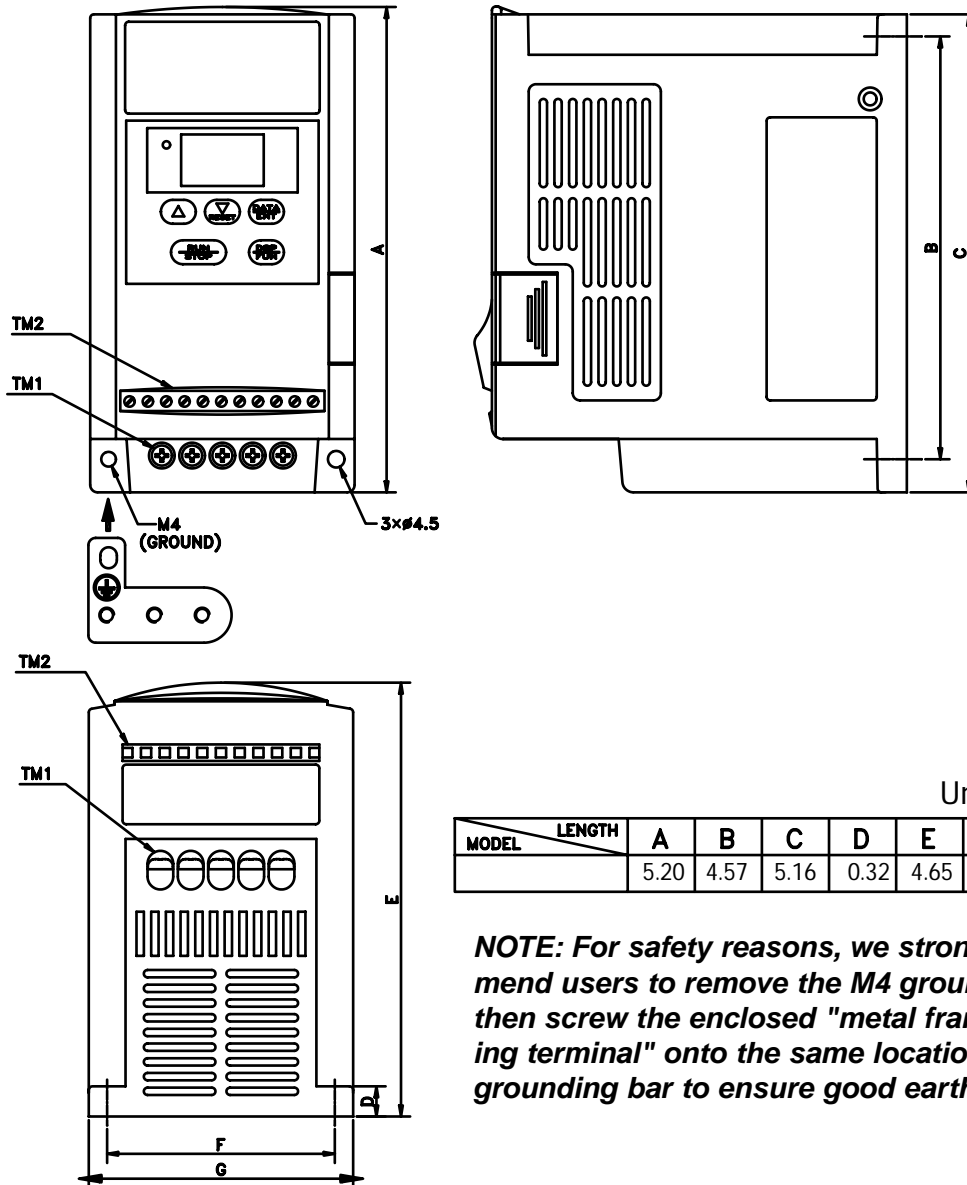

Unit: inches

MODEL	LENGTH	A	B	C	D	E	F	G
		5.20	4.57	5.16	0.32	4.65	2.40	2.83

NOTE: For safety reasons, we strongly recommend users to remove the M4 grounding screw, then screw the enclosed "metal frame grounding terminal" onto the same location to make a grounding bar to ensure good earth protection.

2-3HP, 230V & 1-3HP, 460V:

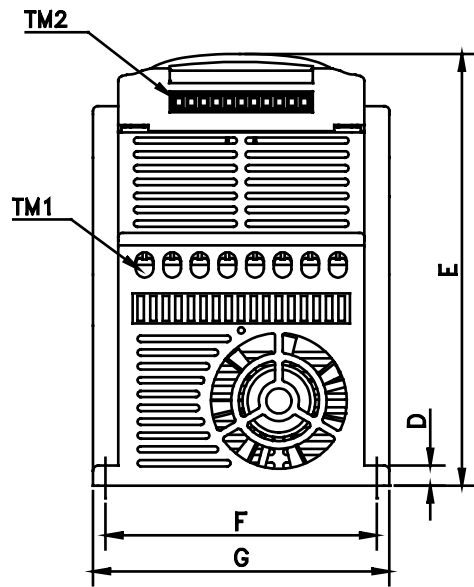
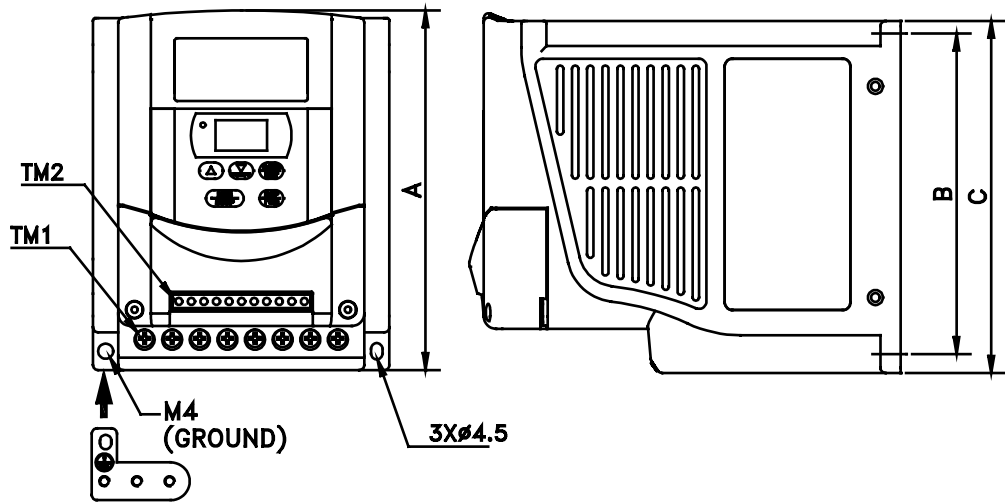

Unit: inches

A	B	C	D	E	F	G
5.63	5.02	5.51	0.32	6.77	4.25	4.65

Dimensions of class B Filter

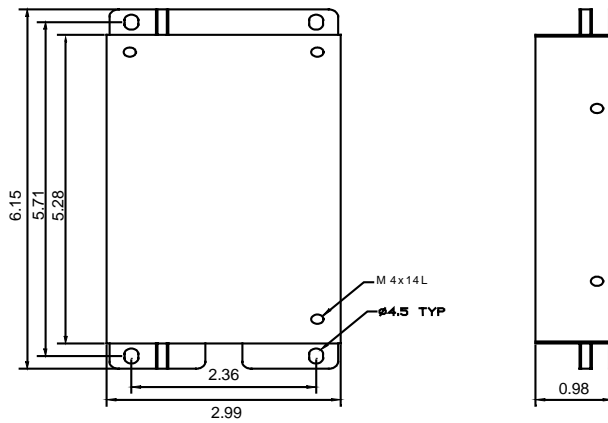

2.6 MOUNTING INSTRUCTIONS - Class B Filter

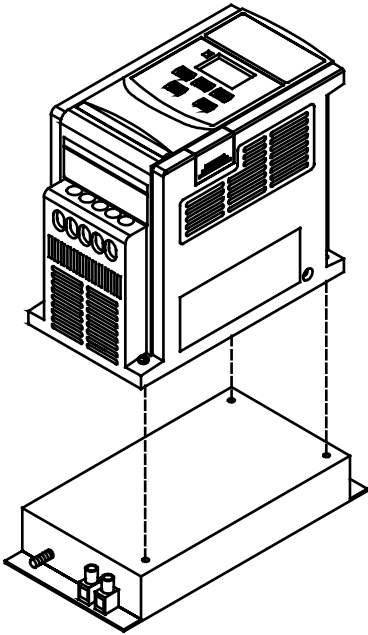

Controller with class B filter mounted.

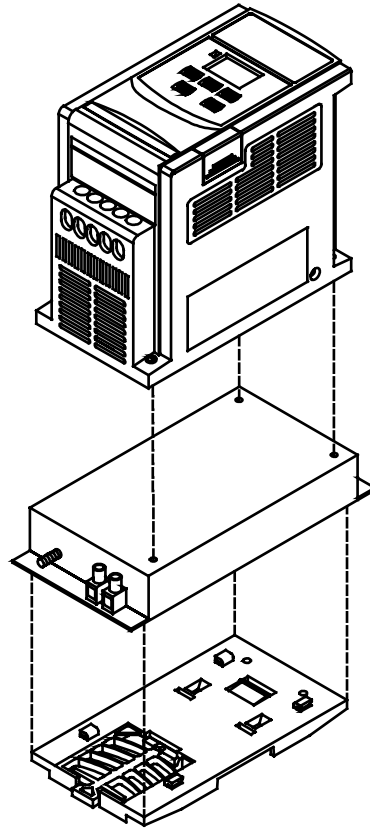

Controller with class B filter & Din rail mounting kit.

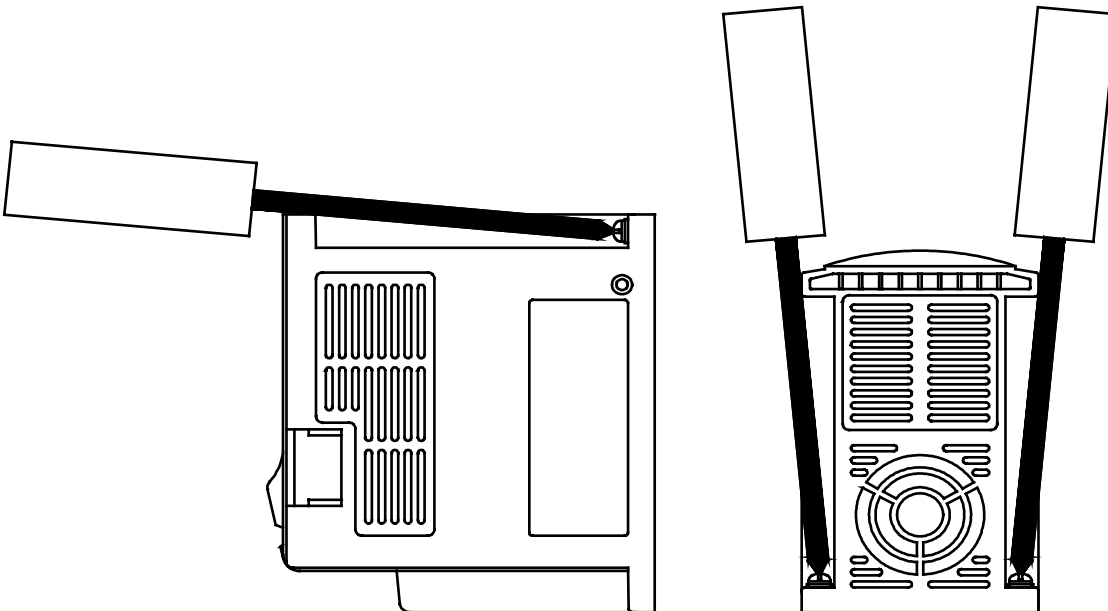

Din Rail Mounting Diagram

Install Controller

Step 1 - Insert the 4 retention ribs of the DIN Rail at the 4 holes in rear panel of controller.

Step 2 - Push the DIN Rail forward until the middle rib grips firmly with back panel.

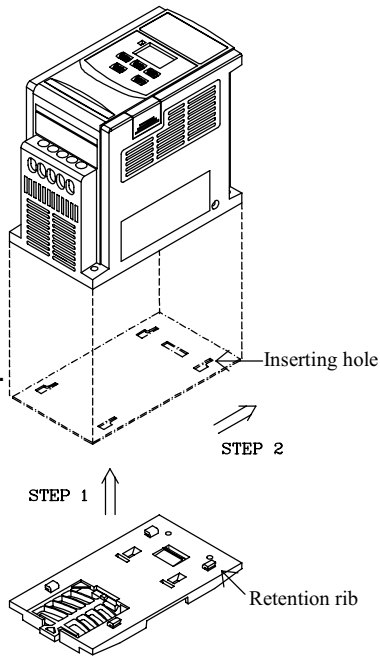

Remove Controller

Step 1- Use a small screwdriver, and insert it into the middle rib of DIN Rail and press the screwdriver in order to remove the DIN Rail from the controller.

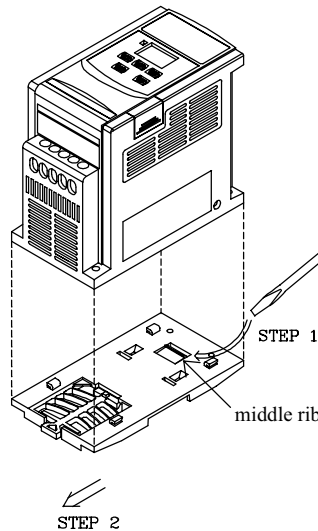

DIN Rail Installation

A mounting clamp and a 1.38" width rail must be used to install the controller on the rail.

Install Controller

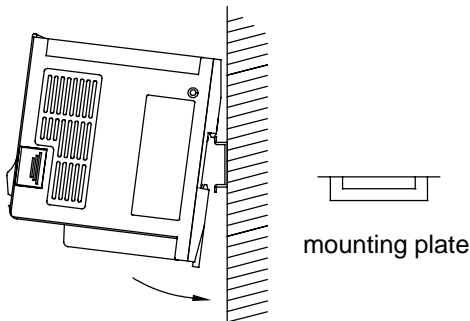

Remove Controller

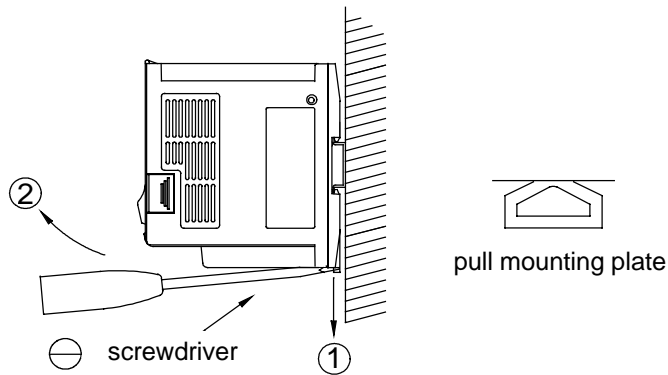

First, place the groove on the back of the controller on the upper edge of the din rail, and then push the controller down to lock up position. Finally, press the mounting plate upward into the controller.

1. Pull the mounting plate downward.
2. Rotate the controller to remove it.

Notes:

3. SOFTWARE INDEX

3.1 KEYPAD OPERATING INSTRUCTIONS

Keypad Description

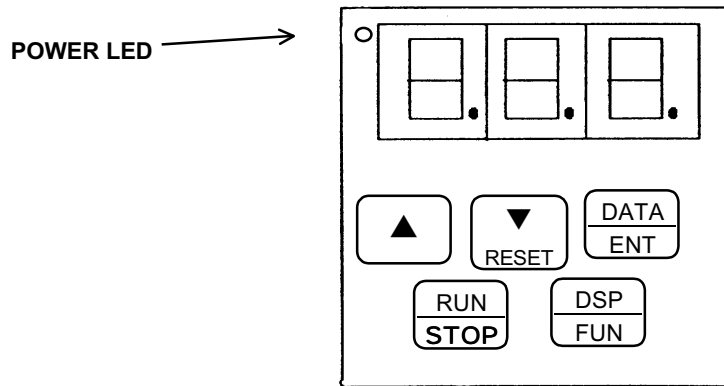

Caution

Do not operate the keypad with a screwdriver or other sharp-ended tool to avoid damaging the keypad.

Brief keypad operation flowchart

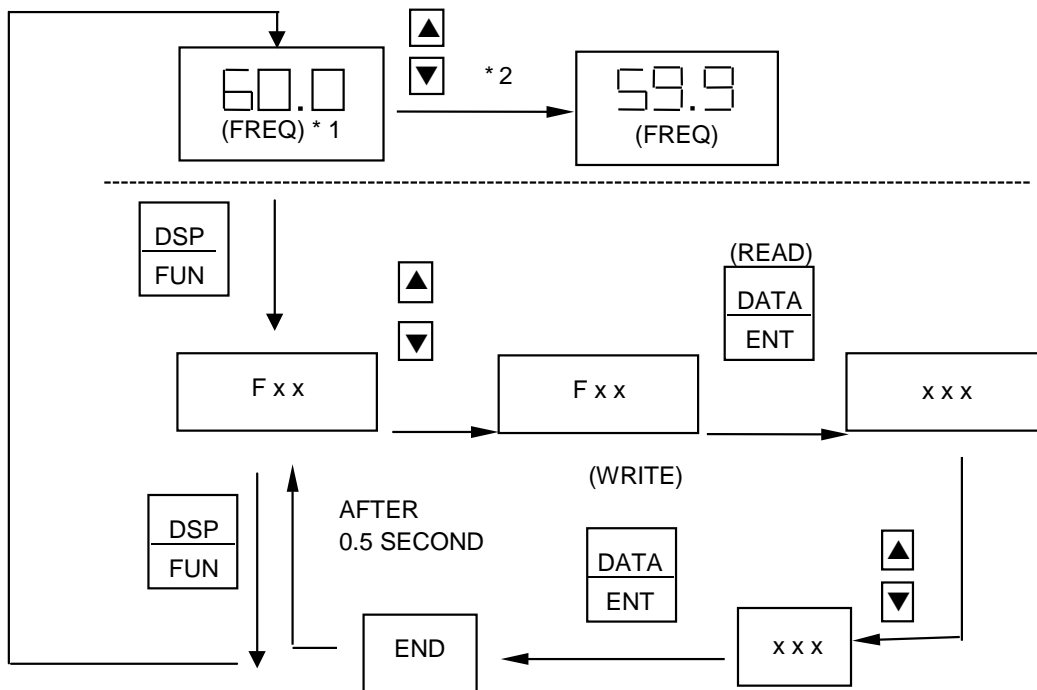

Note *1: Displays frequency setting when stopped. Displays output frequency when running.

Note *2: The frequency setting can be modified either when stopped or when running.

3.2 PARAMETER LIST

Function	F_	Function Description	Unit	Range	Factory Setting	Page	Note
	0	Factory Adjustment			0	28	
Acceleration time	1	Accel. time	0.1Sec	0.1 ~ 999 S	5.0	28	*1 *3
Deceleration time	2	Decel. time	0.1Sec	0.1 ~ 999 S	5.0	28	*1 *3
Operation mode	3	0: Forward / Stop, Reverse / Stop 1: Run / Stop, Forward / Reverse	1	0 1	0	29	
Motor rotation direction	4	0: Forward 1: Reverse	1	0 1	0	29	*1
V/F pattern	5	V/F pattern setting	1	1 ~ 6	1/4	30	*2
Frequency upper/lower limit	6	Frequency upper limit	0.1Hz	1 ~ 200	50/60Hz	31	*2 *3
	7	Frequency lower limit	0.1Hz	1 ~ 200	0.0Hz	31	*3
SPI frequency	8	SP1 frequency	0.1Hz	1 ~ 200	10Hz	31	*3
JOG frequency	9	JOG frequency	0.1Hz	1 ~ 200	6Hz	31	
Start / Stop control	10	0: Keypad 1: Terminal (TM2)	1	0 1	0	32	
Frequency control	11	0: Keypad 1: Terminal (0~10V / 0~20mA) 2: Terminal (4~20mA)	1	0 2	0	32	
Carrier frequency control	12	Carrier frequency setting	1	1 ~ 10	5	33	
Torque compensation	13	Torque compensation gain	0.1%	0.0 ~ 10.0%	0.0%	33	*1
Stop method	14	0: Controlled deceleration stop 1: Coast to stop	1	0 1	0	34	
DC braking setting	15	DC braking time	0.1S	0.0 ~ 25.5S	0.5S	34	
	16	DC braking injection frequency	0.1Hz	1 ~ 10Hz	1.5Hz	34	
	17	DC braking level	0.1%	0.0 ~ 20.0%	8.0%	34	
Electronic thermal overload protection	18	Protection based on motor rated current	1%	0 ~ 200%	100%	34	
Multifunction input connection point	19	Multifunction input terminal 1 (SP1) function	1: Jog 2: SP1 3: Emergency stop		2	35	
	20	Multifunction input terminal 2 (RESET) function	4: External base block 5: Reset 6: SP2		5	35	
Multifunction output	21	Multifunction output terminal	1: Operating 2: Frequency reached 3: Fault		3	36	

Function	F_	Function Description	Unit	Range	Factory Setting	Page	Note
Reverse lock-out	22	0: REV run 1: REV run lock-out	1	0 1	0	37	
Momentary power loss	23	0: Enabled 1: Disabled	1	0 1	0	37	
Auto restart	24	Number of auto-restart times	1	0 ~ 5	0	38	
Factory setting	25	010: Constants default to 50Hz system 020: Constants default to 60Hz system				38	*2
SP2 frequency	26	SP2 frequency	0.1Hz	1.0~200Hz	20	39	
SP3 frequency	27	SP3 frequency	0.1Hz	1.0~200Hz	30	39	
Direct start	28	0: Enabled 1: Disabled	1	0 1	1	39	
Software version	29	CPU program version				39	
Fault log	30	Fault log for three faults.				39	

NOTES:

*1: Indicates this parameter can be adjusted during running mode.

*2: Refer to F_25.

*3: If the setting range is above 100, the setting unit becomes 1.

3.3 PARAMETER FUNCTION DESCRIPTION

F_00 Factory Adjustment Parameter. Do not change.

F_01: Acceleration Time = 0.1 ~ 999 seconds

F_02: Deceleration Time = 0.1 ~ 999 seconds

1. Acceleration / Deceleration time calculation formula:

$$\text{Accelerate time} = \frac{F_{01} \times \text{Setting Frequency}}{60 \text{ Hz}}$$

$$\text{Decelerate time} = \frac{F_{02} \times \text{Setting Frequency}}{60\text{Hz}}$$

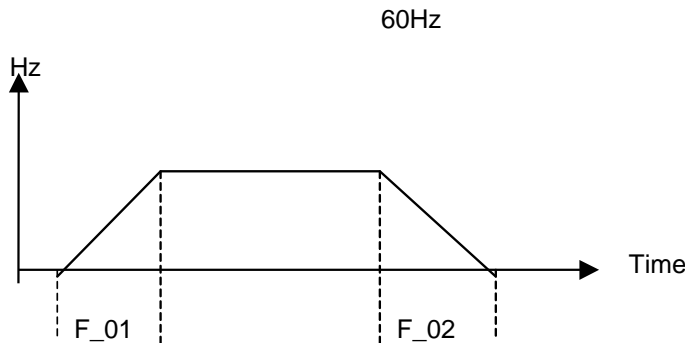

**F_03: Operation Mode Selection = 0: Forward / Stop, Reverse / Stop
1: Run / Stop, Forward / Reverse**

Note 1: F_03 takes affect only when F_10 = 1 (external operation control).

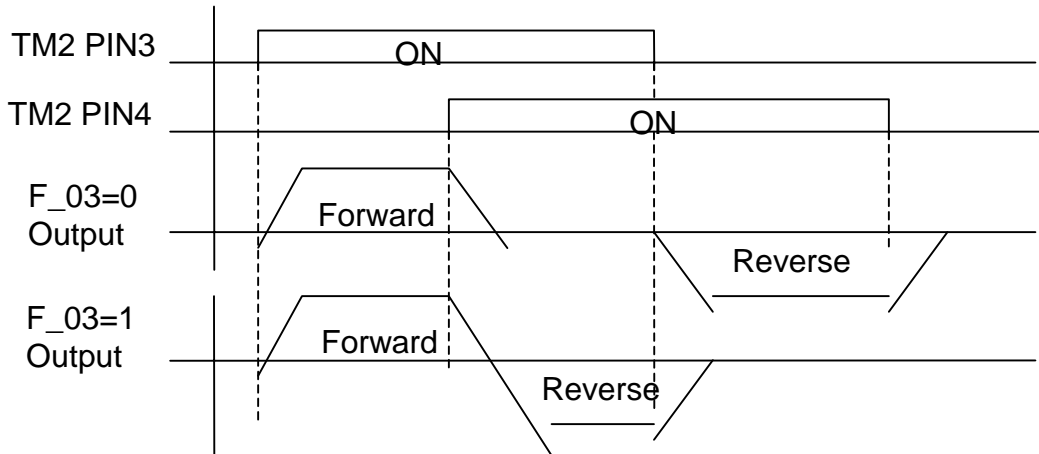
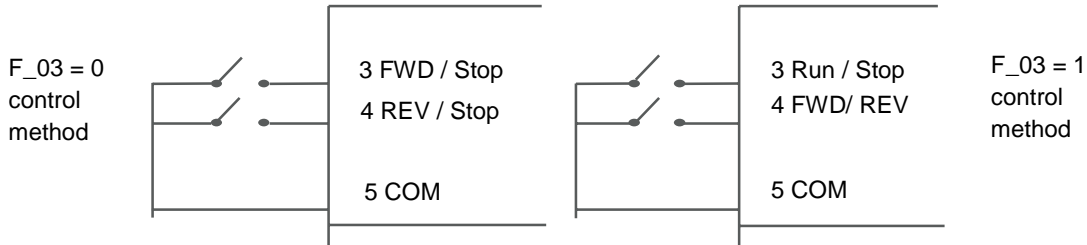

Note: Reverse command is ignored when F_22 = 1.

**F_04: Motor Rotation Direction Setting = 0: Forward
1: Reverse**

Although there is no Forward / Reverse push button on the digital control panel, it is possible to switch forward / reverse functions by changing the F_04 setting.

Note: When F_22 =1: Reverse is disabled, the F_04 cannot be set to 1.

The keypad indication will display "LOC."

F_05: V/F Pattern Setting = 1 ~ 6

Set F_05 = 1 - 6 to select one of the six preset V/F patterns. (Refer to the following tables.)

Specification	50 Hz System		
Application	General application	High starting torque	Decreasing torque
F_5	1	2	3
V/F pattern			
Specification	60Hz System		
Application	General application	High starting torque	Decreasing torque
F_5	4	5	6
V/F pattern			

F_5	B	C
1/4	10%	8%
2/5	15%	10.5%
3/6	25%	7.7%

F_06: Frequency Upper Limit Range = 1 ~ 120Hz

F_07: Frequency Lower Limit Range = 1 ~ 120Hz

F_06: Factory setting refers to F_25.

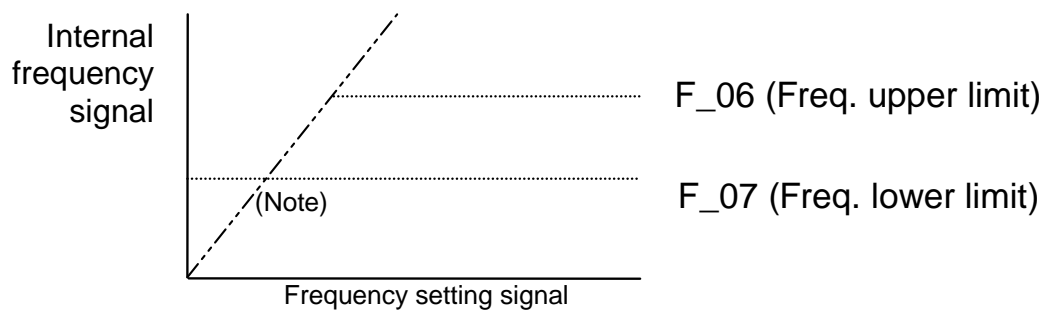

Note:

If F_07 = 0 Hz, The drive will stop at 0 speed.

If F_07 > 0 Hz, The controller will output a minimum speed according to the setting in F_07.

F_08: SP1 Frequency = 1 ~ 200 Hz

F_09: JOG Frequency = 1 ~ 200 Hz

1. When F_19 or F_20 = 2 and the multifunction input terminal is ON, the drive operates at sp1 frequency (F_08).
2. When F_19 or F_20 = 1 and the multifunction input terminal is ON, the drive operates at jog frequency (F_09).
3. The priority of reading frequency setting is: Jog, Sp1, keypad setting, or external frequency signal using a speed pot.

F_10: Start / Stop Control = 0: Keypad
 = 1: Terminal (TM2)

Note: When F_10 = 1 (Terminal Control), the emergency stop on the Keypad is enabled.
 When F_10 = 1, refer to the descriptions of F_23/24 to avoid personal injury and machine damage.

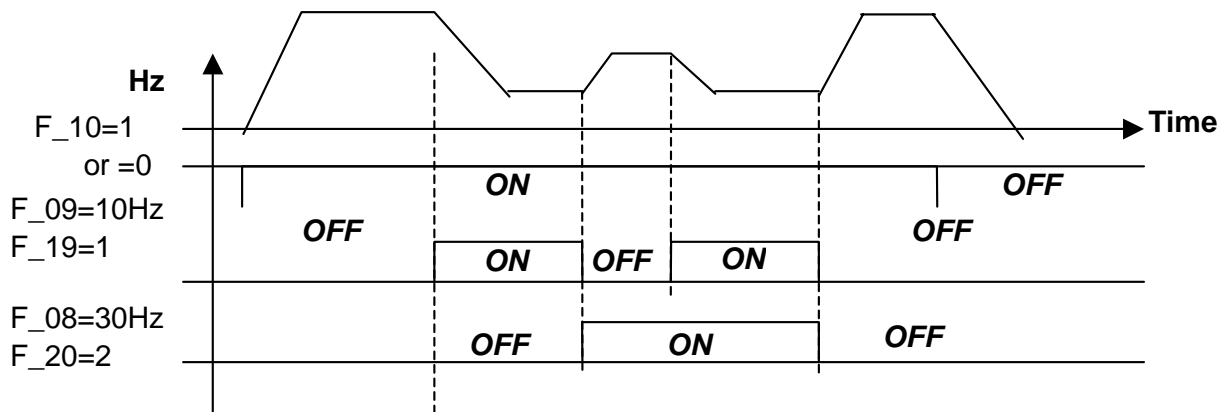

F_11: Speed Control = 0: Keypad
 = 1: Analog Speed Pot Terminal (TM2) (0 ~ 10V / 0-20mA)
 = 2: Analog Speed Pot Terminal (TM2) (4-20mA)

Note 1:
 When jog frequency or SP1 frequency is switched ON, the frequency is set by SP1 speed, and the ▲▼ buttons on the keypad are disabled. Original setting will be restored after the Sp1 connection is removed.

Note 2:
 During the contact closure of the jog function, the keypad control is disabled until the jog contact connection is re-opened.

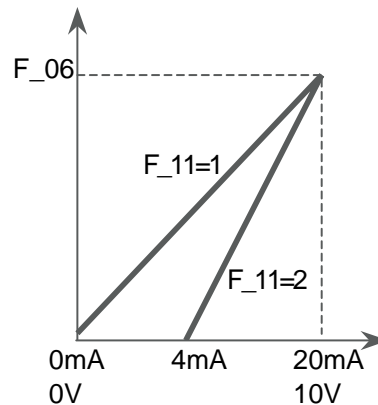

See the SW1 Function Description on page 21.

F_12: Carrier Frequency = 1 ~ 10

F_12	Carrier frequency	F_12	Carrier frequency	F_12	Carrier frequency
1	4 kHz	5	8 kHz	9	15 kHz
2	5 kHz	6	10 kHz	10	16 kHz
3	6 kHz	7	12 kHz		
4	7.2 kHz	8	14.4 kHz		

Note:

If $F_{12} = 7\sim 10$, the drive load must be light.

Although an IGBT type controller can provide a low audible noise level during operation, it is possible that the switching of the high carrier frequency may interfere with external electronic components (or other controllers) or even cause vibration in the motor. Adjusting the carrier frequency can usually correct this problem.

F_13: Torque Compensation Gain = 0 ~ 10 %

To enhance controller output torque patterns according to the B, C voltage points on the V/F pattern, refer to F_05 and F_13 descriptions.

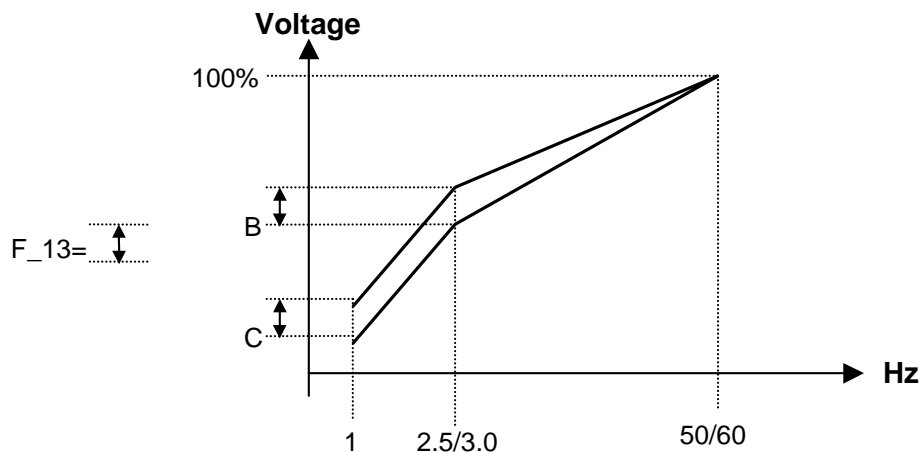

Note: When $F_{13} = 0$, the torque boost function is disabled.

F_14 Stopping Method = 0: Controlled deceleration stop

= 1: Coast to stop

F_15 DC Braking Time = 0 ~ 25.5 seconds

F_16 DC Braking Starting Frequency = 1 ~ 10Hz

F_17 DC Braking Level = 0 ~ 20%

If F_14 = 0

When the controller receives a stop command, the drive decelerates to the preset frequency set by F_16. After this, the output voltage level set in F_17 will determine the amount of DC voltage that's injected into the motor. The time duration to perform this stopping function is set in F_15.

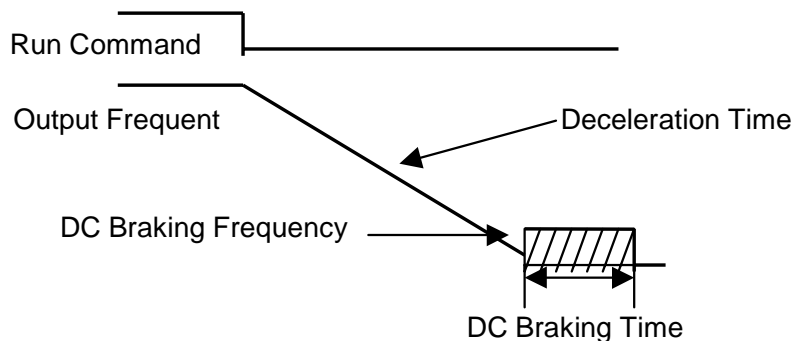

If F_14 = 1

The controller stops output immediately after receiving the stop command. The motor will enter into a coast state until it comes to a complete stop.

F_18: Motor Rated Current = 0 ~ 200 %

1. Electronic thermal overload protection for the motor:

(1) Motor rated current = Controller rated current x F_18

$F_{18} = \text{Motor rated current} / \text{controller rated current}$

(2) When the load is within 100% of motor rated current, operation continues.

When the load reaches 150% of motor rated current, operation continues for 1 minute. (Refer to curve (1) in Figure 3 on page 35.)

(3) After the electronic thermal switch activates, the controller will shut down immediately, and the OLI light will flash. To resume operation, push the RESET button or activate an external reset contact wired to terminal 2.

(4) When the motor is operating at low speed, the heat dissipation efficiency is lower. The electronic thermal activation level is also reduced. To change from curve (1) to curve (2) in Figure 3, choose the appropriate F_05 setting to achieve the desired performance.

2. Electronic thermal overload protection for the controller:

(1) When the load is within 103% of controller rated current, operation continues. When the load reaches 150% of controller rated current, operation will continue for 1 minute. (Refer to curve (1) in Figure 3.)

(2) After the electronic thermal switch activates, the controller will shut down immediately, and the OL2 light will flash. To resume the operation, push RESET button or activate an external reset contact wired to terminal 2.

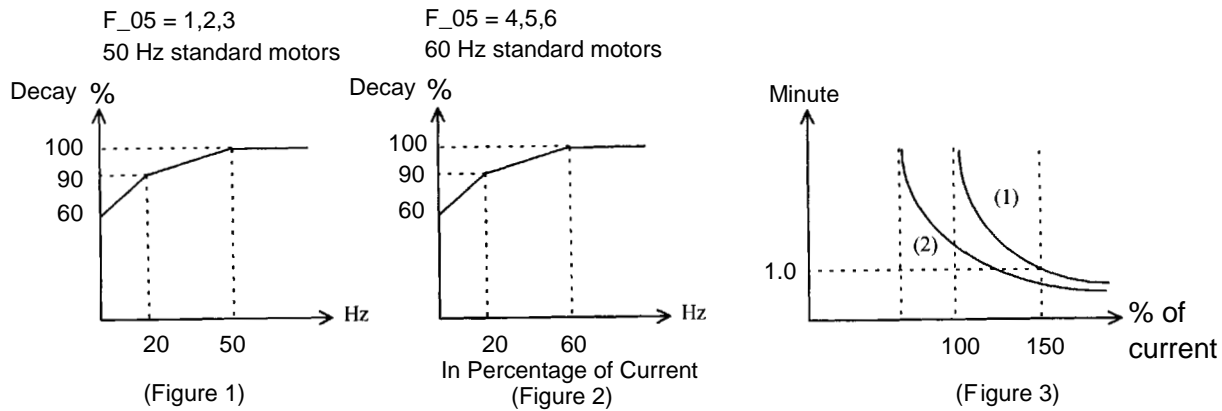

F_19: Multifunctional Input Terminal 1 Function = 1~ 6

F_20: Multifunctional Input Terminal 2 Function = 1~ 6

1. F_19 = 1 or F_20 = 1: JOG control (refer to F_09)
2. F_19, F_20 = 2 or 6 Multi-speed control:
F_19 = 2 & F_20 = 6:

TM2 SP1 Terminal	TM2 RESET Terminal	Output Frequency
ON	OFF	F_08
OFF	ON	F_26
ON	ON	F_27

F_19 = 6 & F_20 = 2:

TM2 SP1 Terminal	TM2 RESET Terminal	Output Frequency
ON	OFF	F_26
OFF	ON	F_08
ON	ON	F_27

3. F_19, F_20 = 3: External Emergency Stop

When the external emergency stop signal is activated, the drive decelerates and stops, ignoring the setting of F_14. E.S. will flash on the controller display after stopping. After the emergency stop signal is deactivated, turn the RUN switch OFF and then ON again (F_10 = 1). Or, push the RUN key (F_10 = 0). The drive will then resume operation. If the emergency stop signal is removed before the drive stops, the controller will still execute the emergency stop.

4. F_19, F_20 = 4: External Base Block (Immediate Shut Down)

When the external base block signal is activated, the controller output immediately shuts off (ignoring the setting of F_14), and flashes b.b. on the display. After the base block signal is deactivated, turn the RUN switch OFF and then ON again (F_10 = 1) or push the RUN key (F_10=0), and the drive will restart from the original starting frequency.

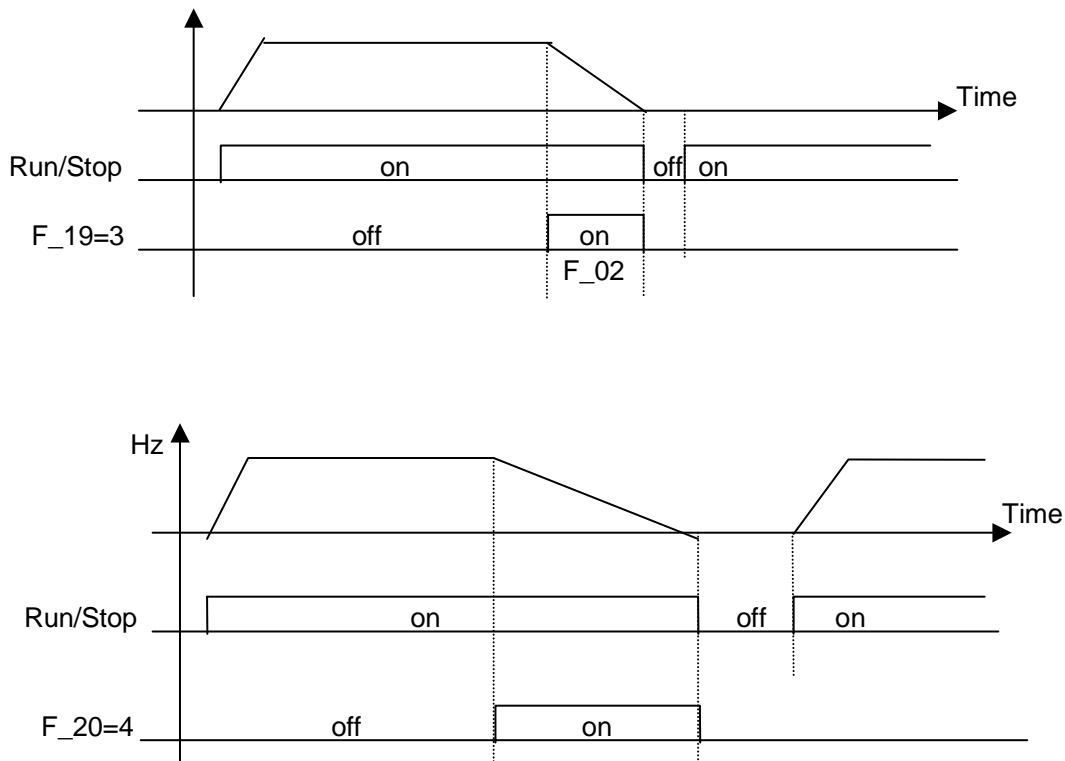

5. F_19, F_20 = 5: Auto reset when the controller faults.

F_21: Multi-function Output Terminal Control = 1 ~ 3

1. F_21 = 1: Run mode signal
2. F_22 = 2: At Frequency speed signal
3. F_21 = 3: Fault signal

Terminals 1 and 2 of TM2 are activated during CPF, OL1, OL2, OCS, OCA, OCC, OCd, OCb, OVC, LVC and OHC faults.

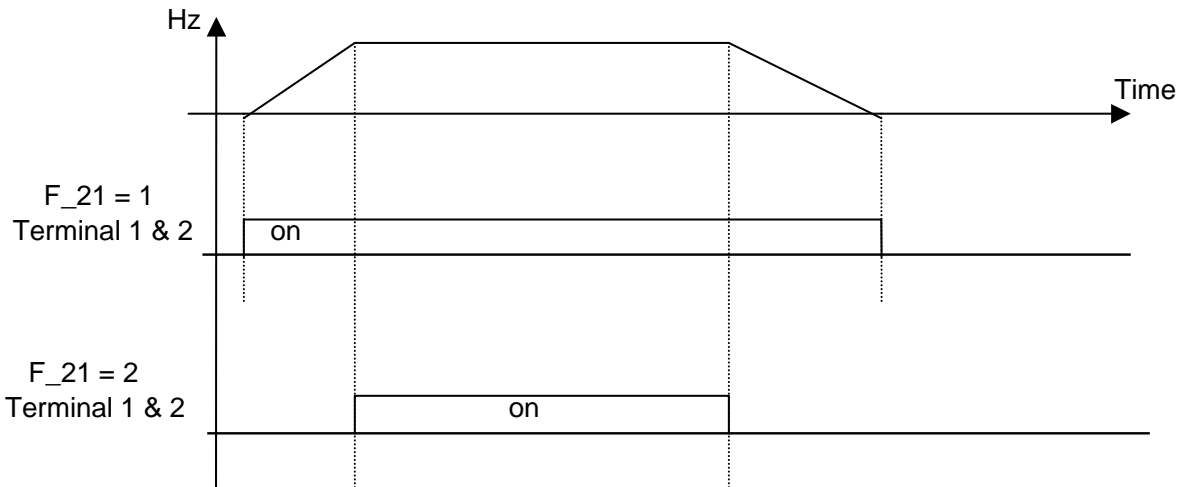

F_22: Reverse Lock-Out = 0: REV command
= 1: REV command lockout

Note:

When F_04 is set to 1 (reverse), F_22 cannot be set to 1. To lock out the motor's direction, F_04 must be set at 0 before setting F_22 to 1.

F_23: Auto-restart After Momentary Power Loss = 0: Auto-restart enabled
= 1: Auto-restart disabled

1. If the AC power supply drops below the low voltage protection level, or if large current loading is encountered in the power supply system, the controller will shut down immediately. If the power source resumes within 2 seconds, the controller can restart by using its speed search program.

2. When F_23 = 0:

(1) If the momentary power loss is less than 2 seconds, the controller will resume operation automatically via speed search 0.5 second after power up. The number of auto-restart times is not limited by F_24.

(2) If the momentary power loss is longer than 2 seconds, the operation of the controller is based on the setting of F_10 and the condition of an external switch (FWD/REV button).

(3) If the time of momentary power loss is between the above two, whether the controller will auto-restart depends on the F_24 setting:

F_24 = 0: Auto-restart disabled.

F_24 = 1~5: Auto-restart enabled 1~5 times.

3. When F_23 = 1:

- (1) When the controller is powered up after a momentary power loss, it will not start, even if $F_{24} > 0$.
- (2) If the momentary power loss is long, the controller must be restarted manually. The operation of the controller is based on the setting of F_10 and the condition of the external switch.

4. After restarting the controller, the operation of the controller is based on the setting of F_10 and the setting of the external switch (FWD/REV button).

- (1) When $F_{10} = 0$, the controller will not start after a restart command.
- (2) When $F_{10} = 1$ and the external switch (FWD/REV button) is OFF, the controller will not start after a restart command.
- (3) When $F_{10} = 1$ and the external switch (FWD/REV button) is ON, the controller will start automatically after a restart command. For reasons of safety, be sure to turn off the external switch (FWD/REV button) after a power loss to avoid possible damage to the machine and personal injury after a sudden regeneration of power.

F_24: Number of Auto-restart Times = 0~5

1. When $F_{24} = 0$: The controller will not auto-restart after an interruption of operation, except for a momentary power loss. (See F_23 for details.)
2. When $F_{24} = 1\sim 5$: The controller will resume operation via speed search after 0.5 second under auto-restart after an interruption of operation, except for a momentary power loss. (See F_23 for details.)
3. When the controller is set to decelerate or DC brake, the transient restart procedure will not occur.
4. If either of the following situations occur, the auto restart times will reset:
 - (1) No additional interruption in operation or a stop occurs within 10 minutes.
 - (2) The RESET button is pressed.

**F_25: Return to Factory Settings = 010: Parameters restored to 50Hz system
= 020: Parameters restored to 60Hz system**

1. When F_25 is set to 010, all parameters are restored to factory settings for 50Hz operation. The settings of $F_{05} = 1$ and $F_{06} = 50$. F_25 is restored to 000 after the reset process is complete.
2. When F_25 is set to 020, all parameters are restored to factory settings for 60Hz operation. The settings of $F_{05} = 4$ and $F_{06} = 60$. F_25 is restored to 000 after the reset process is complete.

F_26: SP2 (1~200Hz), Multi-speed 2 (Refer to F_19 / F_20)

F_27: SP3 (1~200Hz), Multi-speed 3 (Refer to F_19 / F_20)

**F_28: Direct Start = 0: Direct start enabled when remote Run command is on
= 1: Direct start disabled when remote Run command is on**

When F_28 = 1 and the control mode is Remote Control (F_10 = 1), the controller cannot start if the RUN switch is ON when power is applied. The RUN switch must be turned OFF and turned ON again before the controller will start.

F_29: CPU program version

F_30: Last three faults

1. Last three faults: Indicates the sequence of the occurrence of malfunctions by the location of a decimal point. **x.xx** indicates a recent malfunction. **xx.x** indicates the last malfunction that happened. **xxx.** indicates the first malfunction in the record.
2. After entering the F_30 function, the **x.xx** trip record will be displayed first. After that, press the ▲ button and read activity in a chronological order. **xx.x → xxx. → x.xx →,,,** consecutively.
3. After entering the F_30 function, and the RESET button is pressed, the trip record will be cleared. Indication display **-.-, --.-, and ---.**
4. When the contents of trip indicates O.CC, the latest trip code will be OC-C, and so on.

3.4 MALFUNCTION INDICATIONS AND COUNTERMEASURES

1. Manual Reset Inoperative Malfunctions

INDICATION	CONTENT	POSSIBLE CAUSE	COUNTERMEASURE
CPF	Program error	Outside noise interference	Place an RC surge absorber in parallel with the noise generating magnetic contact
EPR	EEPROM error	EEPROM defective	Replace EEPROM
OV	Voltage too high when not operating	1. Power source voltage too high 2. Detection circuitry defective	1. Examine the line supply 2. Return the controller for repair
LV	Voltage too low when not operating	1. Power source voltage too low 2. Detection circuitry defective	1. Examining the line supply 2. Return the controller for repair
OH	Controller over heats when not operating	1. Detection circuit defective 2. Environment overheat or poor ventilation	1. Return the controller for repair 2. Improve ventilation

2. Manual Reset Operative Malfunctions (Auto-Reset Inoperative)

INDICATION	CONTENT	POSSIBLE CAUSE	COUNTERMEASURE
OC	Over-current at stop condition	Detection circuit malfunction	Return the controller for repair
OL1	Motor overload	1. Excessive load 2. Incorrect V/F setting 3. Incorrect F_18 setting	1. Increase capacity of motor 2. Adjust to use a proper V/F curve setting 3. Adjust F_18 according to instructions
OL2	Controller overload	1. Excessive load 2. Incorrect V/F setting	1. Increase capacity of controller 2. Adjust to use a proper V/F curve setting

3. Manual Reset and Auto-Reset Operative Malfunction

INDICATION	CONTENT	POSSIBLE CAUSE	COUNTERMEASURE
OCS	Transient over-current when starting	<ol style="list-style-type: none"> 1. Motor shorted to external casing 2. Motor connection wire shorted or grounded 3. Transistor module damaged 	<ol style="list-style-type: none"> 1. Examine the motor 2. Examine the wiring 3. Replace the transistor module
OCA	Over-current at acceleration	<ol style="list-style-type: none"> 1. Acceleration time setting too short 2. Incorrect V/F selection 3. Motor capacity exceeds controller capacity 	<ol style="list-style-type: none"> 1. Adjust acceleration time to a longer time setting 2. Adjust to a proper V/F curve 3. Increase controller capacity
OCC	Over-current at steady speed	<ol style="list-style-type: none"> 1. Oscillating load 2. Fluctuating line supply 	<ol style="list-style-type: none"> 1. Examine the load configuration 2. Install an inductor on the line supply input
OCd	Over-current at deceleration	Deceleration setting too short	Adjust deceleration time to a longer time setting
OCb	Over-current at braking	DC braking frequency, braking voltage, or braking time setting too long	Reduce setting of F_15, F_16, or F_17
OVC	Over-voltage at operation/ deceleration	<ol style="list-style-type: none"> 1. Deceleration time setting too short or load inertia too large 2. Line supply voltage fluctuation too large 	<ol style="list-style-type: none"> 1. Adjust for a longer deceleration time 2. Install an inductor on the line supply input
LVC	Insufficient voltage level at operation	<ol style="list-style-type: none"> 1. Line supply voltage too low 2. Line supply voltage variation too large 	<ol style="list-style-type: none"> 1. Improve line supply quality 2. Adjust for a longer acceleration time 3. Increase capacity of controller 4. Install a reactor on the line supply input
OHC	Heat-sink over heated at operation	<ol style="list-style-type: none"> 1. Excessive load 2. Ambient temperature too high or poor ventilation 	<ol style="list-style-type: none"> 1. Reduce the load 2. Increase capacity of controller 3. Improve ventilation

Special Condition Description

INDICATION	CONTENT	DESCRIPTION
SP0	Zero speed stopping	When F_11 = 0, F_7 = 0 and frequency setting < 1 Hz When F_11 = 1, F_7 < (F_6/100), and frequency setting < (F_6/100)
SP1	Fail to start directly	1. If the controller is set to external operation (F_10 = 1) and direct start is disabled (F_28 = 1), the controller cannot be started, and will flash SP1 when the operation switch is turned ON after applying power (see description of F_28). 2. Direct start is possible when F_28 = 0.
SP2	Keypad emergency stop	The controller is set to external operation (F_10=1). If the STOP key on the keypad is pressed at the middle of operation, the drive stops according to the setting in F_14 and flashes SP2 after stop. The RUN switch must be turned OFF then ON to restart the drive.
E.S.	External emergency stop	When the external emergency stop signal is activated through the multifunction input terminal, the controller decelerates and stops. Controller flashes E.S. after stop. (Refer to instructions for F_19 for details.)
b.b.	External BASE BLOCK	When the external BASE BLOCK signal is activated through the multifunction terminal, the controller shuts down immediately and flashes b.b. (Refer to instructions for F_19 for details.)

Keypad Operation Error Instructions

INDICATION	CONTENT	POSSIBLE CAUSE	COUNTERMEASURE
LOC	Motor direction locked	1. Attempt to reverse direction when F_22 = 1 2. Attempt to set F_22 to 1 when F_04 = 1	1. Set F_22 to 0 2. Set F_04 to 0
Er1	Keypad operation error	1. Press▲ or ▼ key when F_11 = 1 or under SP1 operation 2. Attempt to modify F_29 3. Attempt to modify a parameter that is not allowed to be modified during operation (refer to parameter list)	1. Use▲ or ▼ key to adjust frequency setting only when F_11 = 0 2. Do not modify F_29 3. Modify the parameter in the stop mode
Er2	Parameter setting error	$F_6 \leq F_7$	$F_6 > F_7$

3.5 GENERAL MALFUNCTION EXAMINATION METHOD

ABNORMALITY	CHECK POINT	COUNTERMEASURE
Motor inoperative	Is line voltage applied to L1, L2, L3 terminals (is the charging indicator illuminated)?	<ul style="list-style-type: none"> ● Check if the power source is on. ● Turn power source OFF and then ON again. ● Reconfirm the line voltage level.
	Is there voltage at output terminals T1, T2 and T3?	<ul style="list-style-type: none"> ● Turn power source OFF and then ON again.
	Is the motor wired correctly?	<ul style="list-style-type: none"> ● Check motor wiring.
	Are there any abnormal controller conditions?	<ul style="list-style-type: none"> ● Refer to malfunction handling instructions to examine and correct wiring.
	Is the forward or reverse instruction loaded?	
Motor inoperative	Is the analog frequency setting loaded?	<ul style="list-style-type: none"> ● Check if the wiring for the analog frequency input signal is correct.
	Is the operation mode setting correct?	<ul style="list-style-type: none"> ● Check if the frequency input setting voltage is correct.
Motor operates in opposite direction	Is the wiring on output terminals T1, T2 and T3 correct?	<ul style="list-style-type: none"> ● Operate by digital?
	Is the wiring for the forward and reverse signals correct?	<ul style="list-style-type: none"> ● Wiring should be in accordance with the U, V, W terminals of the motor.
Motor operation speed fixed	Is the wiring for the analog frequency input correct?	<ul style="list-style-type: none"> ● Examine the wiring and correct it.
	Is the operation mode setting correct?	<ul style="list-style-type: none"> ● Examine the wiring and correct it.
	Is the load excessive?	<ul style="list-style-type: none"> ● Reduce the load.
Motor operates at speeds too high or too low	Is the specification of the motor (poles, voltage) correct?	<ul style="list-style-type: none"> ● Check motor specification.
	Is the gear ratio correct?	<ul style="list-style-type: none"> ● Check gear ratio.
	Is the highest output frequency setting correct?	<ul style="list-style-type: none"> ● Check highest output frequency.
	Is the motor voltage too low?	<ul style="list-style-type: none"> ● Check motor voltage.
Abnormal speed variation at operation	Is the load excessive?	<ul style="list-style-type: none"> ● Increase controller and motor capacity.
	Is the load variation too large?	<ul style="list-style-type: none"> ● Reduce load variation.
	Is the input power source steady and stable?	<ul style="list-style-type: none"> ● Install an AC reactor on the line supply.

4. TROUBLESHOOTING PROCEDURES

4.1 FLOW CHART

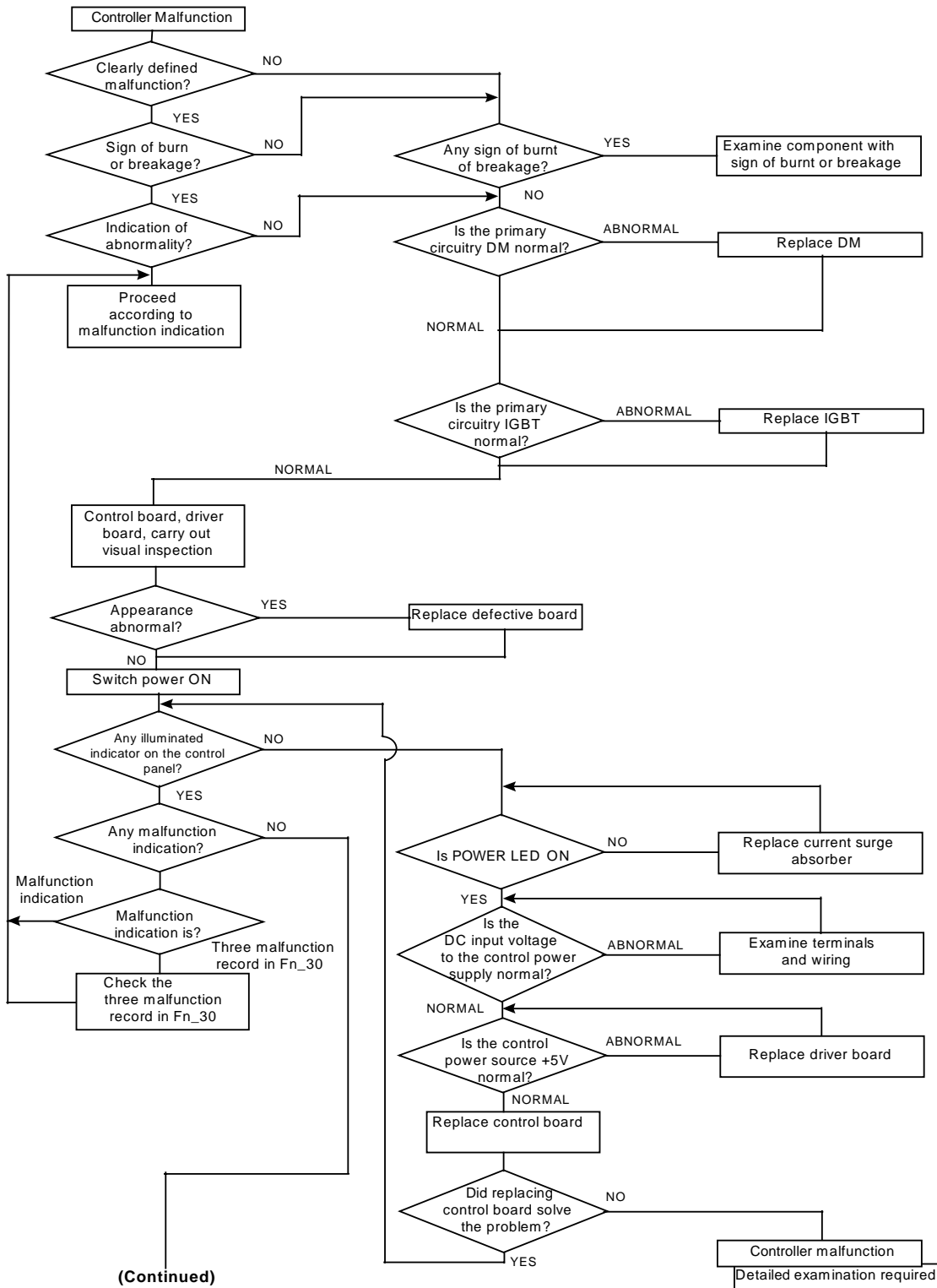

(Continued)

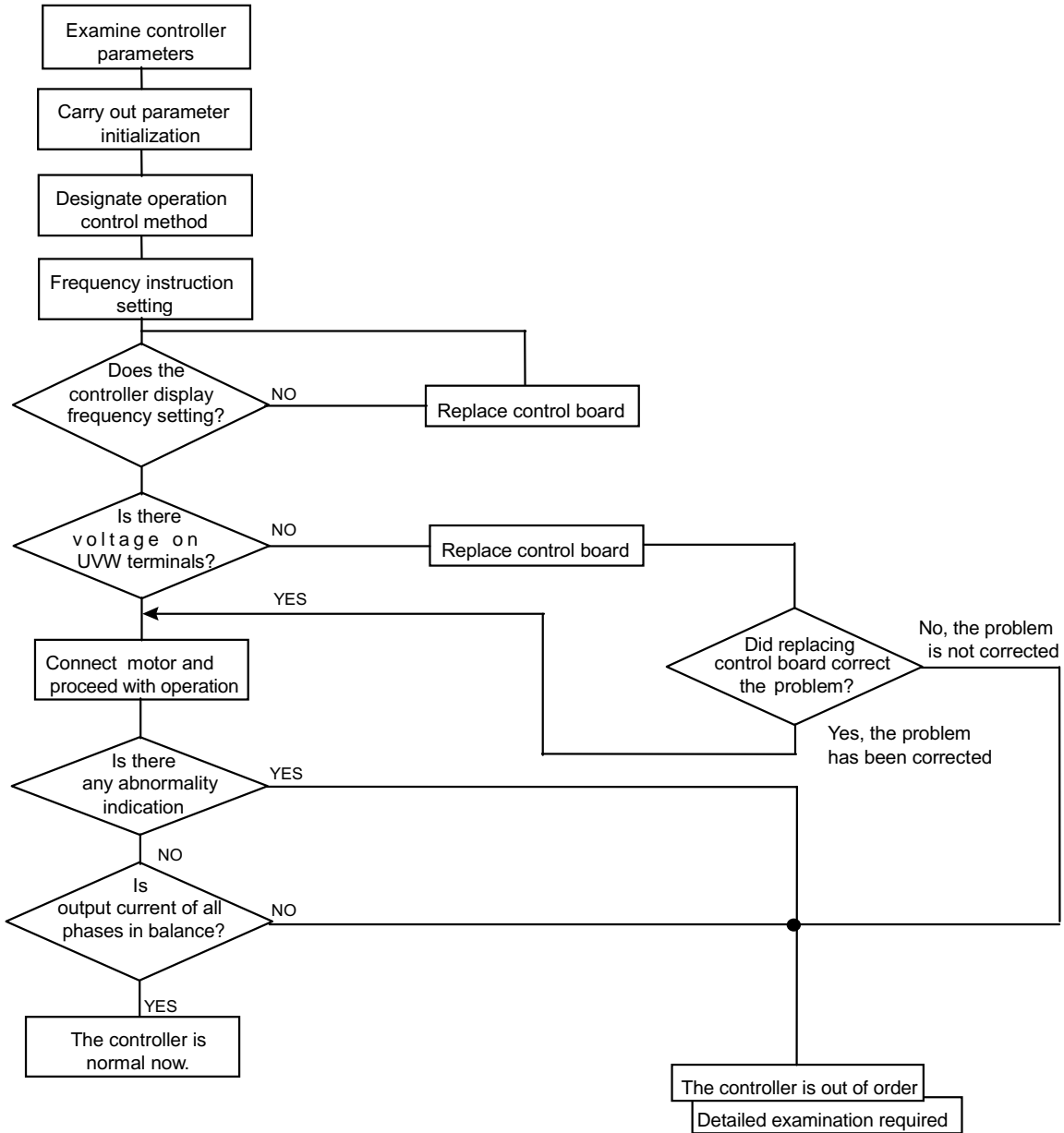

Error handling of malfunction indication of OC.O.L

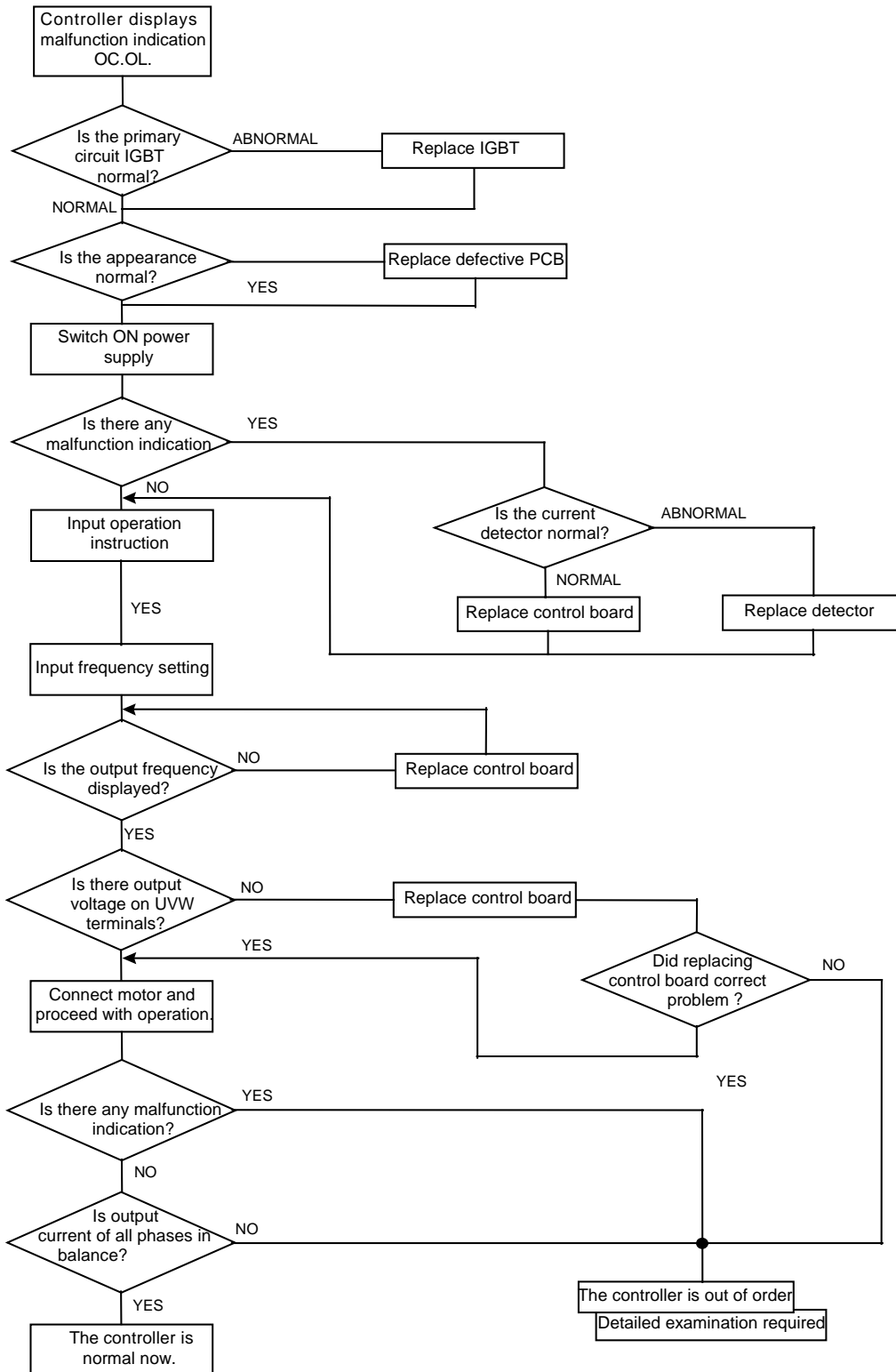

Error handling of malfunction indication of OV.LV

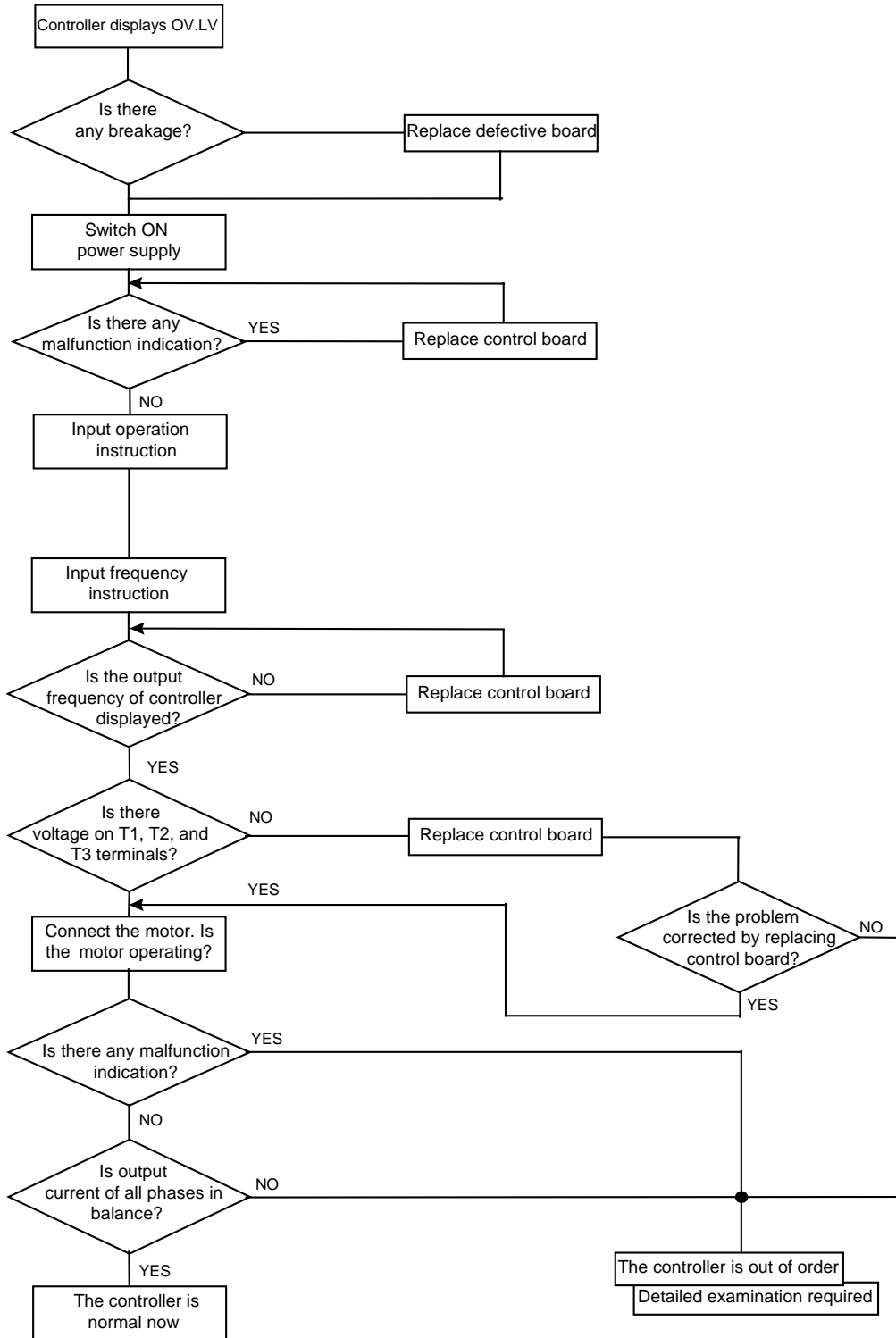

(1) Motor inoperative

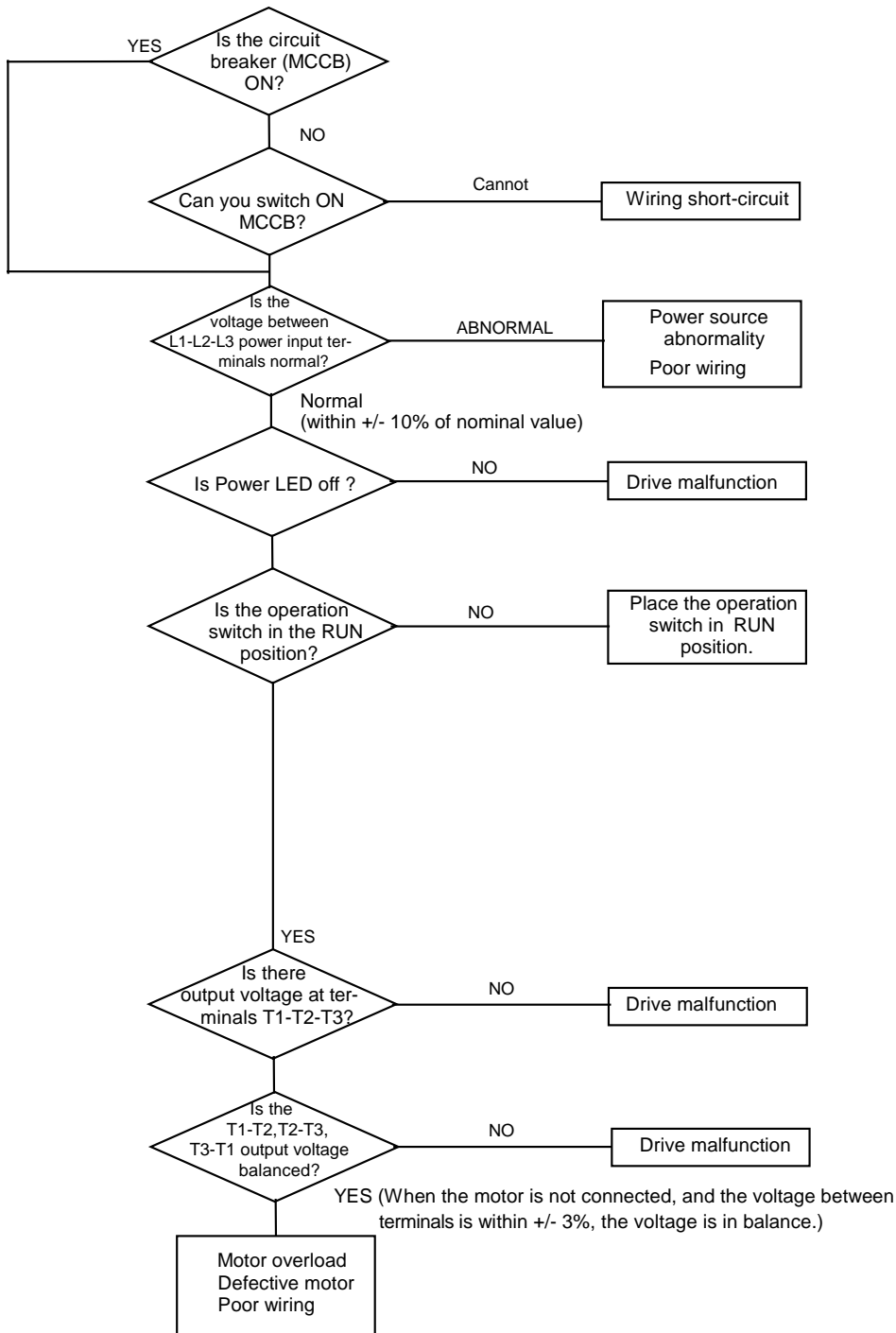

(2) Motor overheating

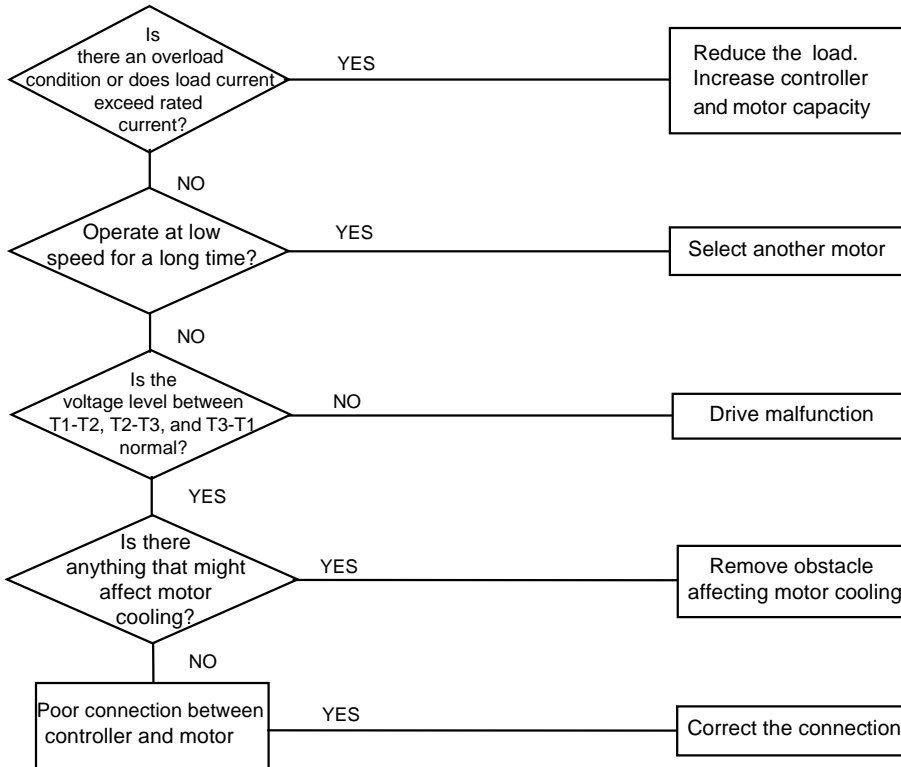

(3) Disturbing motor operation

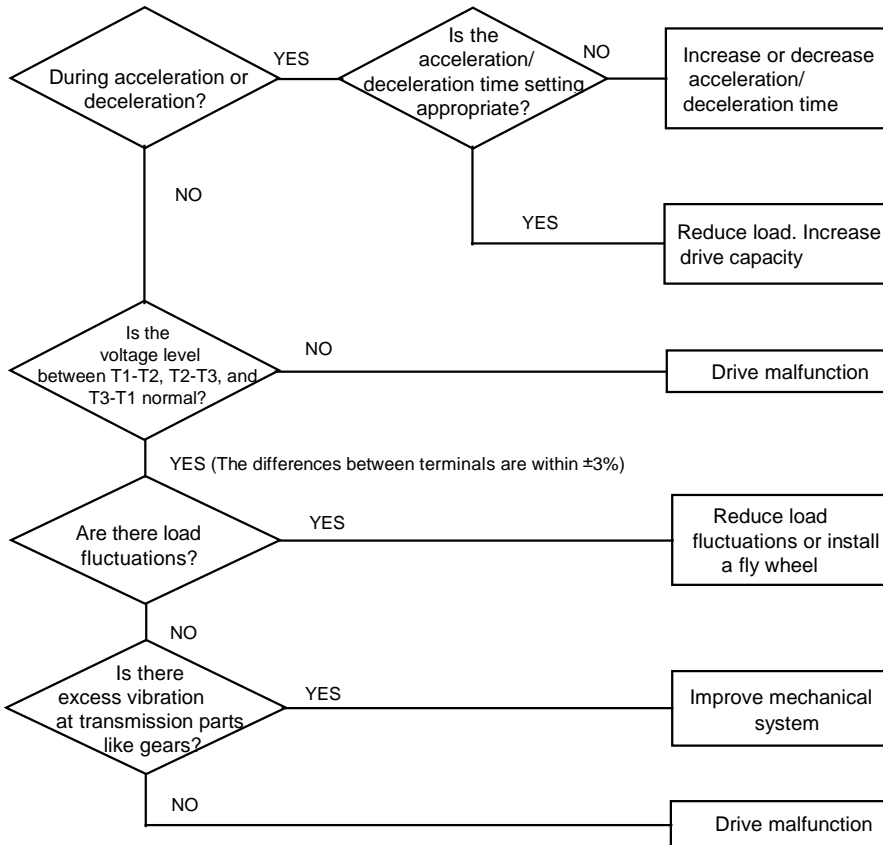

4.2 ROUTINE AND PERIODIC EXAMINATION

The controller requires routine and periodic examination and maintenance. Carry out the examination only after the "Power LED" indicator turns off for at least 5 minutes.

Maintenance Item	Maintenance Description	Examination Period		Examination Method	Criterion	Countermeasure
		Routine	1 Year			
Installation site environment	Check environment temperature and humidity	○		Refer to installation instructions and measure with thermometer and hygrometer	Temperature: 14~104 degrees F. Humidity: under 95% without condensing	Improve installation site environment
	Check and remove any flammable material nearby	○		Visual inspection	No foreign object	
Controller Installation and Grounding	Is there any abnormal vibration on the installation site?	○		Visual and audio inspection	No foreign object	Tighten loose screws
	Is the grounding resistance within acceptable range?		○	Measure resistance with multimeter	200V class under 100 ohms	Improve grounding
Input power source voltage	Is the voltage of the line supply normal?	○		Measure voltage with multimeter	Voltage level within specification	Improve input power source
Controller external terminal mounting screws	Are the tighten parts secure?		○	Visual inspection. Use screwdriver to verify screw tightness	No abnormality	Tighten loose screws or return for repair
	Is there any sign of breakage on the terminal panel?		○			
	Is there any obvious rusty condition?		○			
Internal wiring of controller	Is it deformed or skewed?		○	Visual inspection	No abnormality	Replace or return for repair
	Is the wire insulation broken?		○			
Heat sink	Is it accumulating dust or dirt?	○		Visual inspection	No abnormality	Clean up dust and dirt
PCB	Is it accumulating conductive metal or oil stain?		○	Visual inspection	No abnormality	Clean up or replace PCB
	Are there any overheated or burnt components?		○			
Cooling fan	Is there any abnormal vibration or noise?		○	Visual and audio inspection	No abnormality	Replace cooling fan
	Is it accumulating dust or dirt?	○		Visual inspection		Clean up
Power components	Is it accumulating dust or dirt?		○	Visual inspection	No abnormality	Clean up
Capacitors	Is there any sign of odor or leakage?	○		Visual inspection	No abnormality	Replace capacitor or controller
	Is there any sign of swelling or bulging?	○				

4.3 MAINTENANCE AND EXAMINATION

Frequent examination and maintenance are not required for the controller.

To maintain appropriate reliability, proceed with following periodic examination.

Remember to turn off the power (line) supply and wait until the Power LED goes off before proceeding (due to the large amount of remaining charges in the internal capacitors).

- (1) Clean out internal dust and dirt.
- (2) Check mounting screws on every terminal and part. Tighten loose screws.
- (3) Dielectric strength test.
 - (a) Remove all conducting wires connected to the controller. Power must be turned OFF.
 - (b) The dielectric strength test inside the controller should be carried out only for the controller power circuits. Use DC 500V: high resistance meter. Measured resistance should be higher than 100M ohms.

CAUTION: Do not perform dielectric strength test to the controller control circuitry.

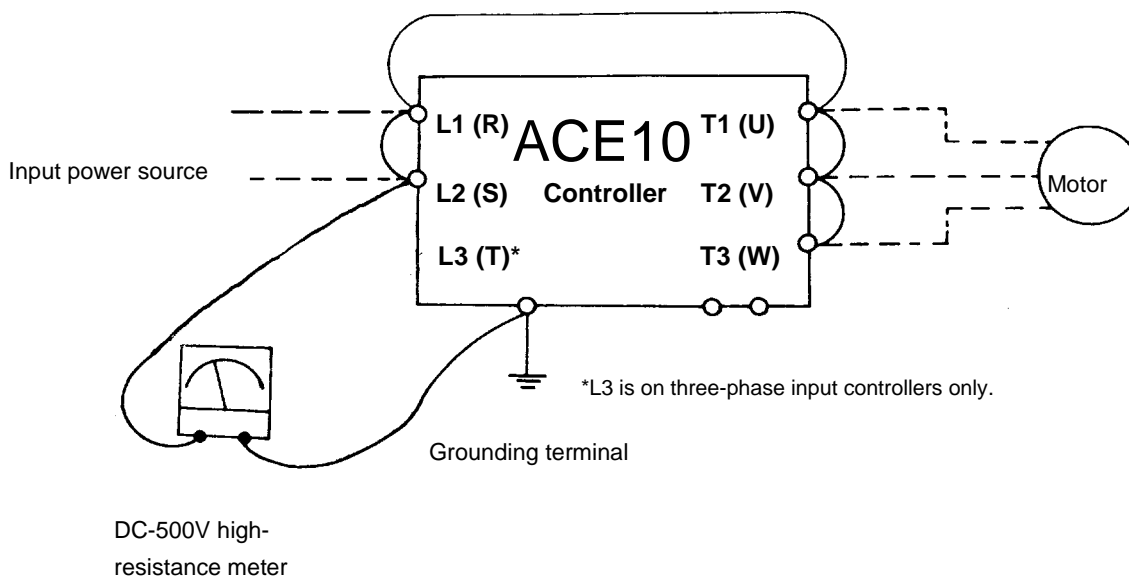

Connection for dielectric strength test

4.4 VOLTAGE & CURRENT MEASUREMENTS

The voltage and current measurements on the primary and secondary side of the controller may be different due to instrument variations. Refer to following diagram for measurements:

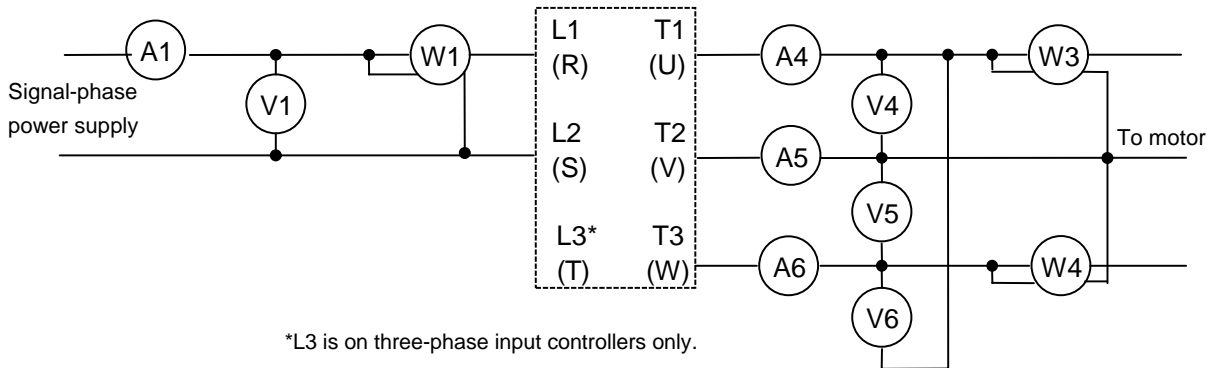

Different kinds of instruments



Measurement	Measuring point	Instrument	Note (Measurement criterion)
Input voltage V_i	(V1)	Moving-iron	
Input current I_i	(A1)	Moving-iron	
Input power P_i	(W1)	Power-meter	$P = W1$
Input power factor PF_i	Calculate power factor by the input voltage, input current and input power $PF_i = \frac{P_i}{\sqrt{3}V_i \cdot I_i} \times 100\%$		
Output voltage V_o	(V4) (V5) (V6)	Rectifier (Moving-iron not allowed)	Maximum voltage difference between wires under 3%
Output Current I_o	(A4) (A5) (A6)	Moving-iron	Under the controller rated current
Output power P_o	(W3) (W4)	Power-meter	$P_o = W3+W4$
Output power factor	$PF_o = \frac{P_o}{\sqrt{3}V_o \cdot I_o} \times 100\%$		

4.5 EMI FILTER (CLASS B) SPECIFICATION

Model	Dimension (in)	Current (A)	Controller Rating
ACE10EMI2F	6.14 x 3.0 x 0.99	10A	1/4HP, 230V 1/2HP, 230V 1HP, 230V
ACE10EMI223	6.77 x 4.73 x 0.43	20A	2HP, 230V 3HP, 230V
ACE10EMI413	6.77 x 4.73 x 0.43	10A	1HP, 460V 2HP, 460V 3HP, 460V

4.6 DIN RAIL SPECIFICATION

Model	Dimension (in)	Controller Rating
ACE10DIN	5.12 x 2.83 x 0.30	1/4, 1/2 & 1HP, 115/230V 2 & 3HP, 230V; 1, 2 & 3HP, 460V

4.7 SPECIFICATION OF BRAKING RESISTOR AND INPUT REACTOR

RATING	Braking transistor built-in	Braking resistor built-in	Torque of braking	Model of braking resistor	Input AC Reactor	
					Current (A)	Inductance (mH)
0.25HP, 230V	X	X	20%	Note 1	3	7.0
0.50HP, 230V	X	X	20%	Note 1	5.2	4.2
1HP, 230V	X	X	20%	Note 1	9.4	2.1
2HP, 230V	○	X	20%	ACE10DBR22	19	1.1
3HP, 230V	○	X	20%	ACE10DBR23	25	0.71
1HP, 460V	○	X	20%	ACE10DBR41	2.5	8.4
2HP, 460V	○	X	20%	ACE10DBR42	5.0	4.2
3HP, 460V	○	X	20%	ACE10DBR43	7.5	3.6

○ : Built-in X: Without built-in

Note 1: Without transistor and resistor built-in.

4.8 SPECIFICATION OF BRAKING RESISTOR

Controller Rating	Model of Braking Resistor	Motor (HP)	Specification of Braking Resistor		Braking Resistor ED(%)	Torque of Braking (%)
			(W)	(Ω)		
2HP, 230V	ACE10DBR22	2	150	100	10	119
3HP, 230V	ACE10DBR23	3	200	70	9	116
1HP, 460V	ACE10DBR41	1	60	750	8	125
2HP, 460V	ACE10DBR42	2	150	400	10	119
3HP, 460V	ACE10DBR43	3	200	250	8	128

Notes:

1. Braking level: 385/770Vdc for 200/400 series.
2. Braking resistor mounting shown below:

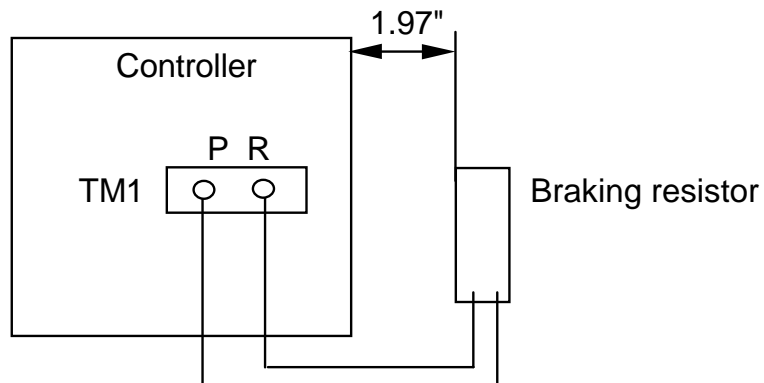

4.9 PARAMETERS TABLE

CUSTOMER		MODEL			
APPLICATION		TELEPHONE			
ADDRESS					
F_##	Value Setting	F_##	Value Setting	F_##	Value Setting
F_00		F_11		F_22	
F_01		F_12		F_23	
F_02		F_13		F_24	
F_03		F_14		F_25	
F_04		F_15		F_26	
F_05		F_16		F_27	
F_06		F_17		F_28	
F_07		F_18		F_29	
F_08		F_19		F_30	
F_09		F_20			
F_10		F_21			

**P/N: ACE10TM
August 2003**

**14 Hayward Street
Quincy, MA 02190
(617) 328-3300
Fax: (617) 479-6238**