

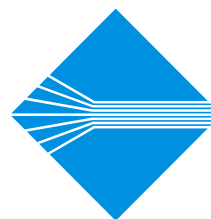

RSi Uni-Torque H Series Drive

Installation, Operation, and
Troubleshooting Manual



BENSHAW
ADVANCED CONTROLS & DRIVES

Publication# 890014-01-06

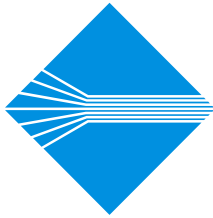

BENSHAW
ADVANCED CONTROLS & DRIVES



Benshaw Inc

1659 E. Sutter Rd Glenshaw, PA 15116

Phone:412-487-8235

Fax:412-487-4201

 **WARNING**

Electrical Shock Prevention

1. Installation, adjustment, repair, and maintenance of the H-series drive must be performed by qualified personnel.
2. The user is responsible for conforming to all applicable code requirements with respect to the wiring and installation of the drive.
3. Do not remove the front cover when input power is applied to the drive.
4. Do not operate the drive with the front cover removed. Electric shock can occur due to the exposed terminals and bus bars.
5. Do not remove the front cover except for routine inspections or installation, even if the input power is not applied. The capacitor bank may remain charged for some time even when the power is not applied.
6. Wait at least 10 minutes after removing input power before wiring or performing routine checkups to allow the DC bus capacitors to discharge. Verify that the DC bus voltage is discharged with a tester. (Below DC 30V)
7. Verify that the drive is solidly grounded.
8. Connect wiring to the drive after the drive has been firmly mounted.
9. Electrical shock may occur if the cable insulation is damaged. Insure proper mounting of equipment to minimize excess stress on the power cables.
10. More than one disconnect switch may be required to de-energize the equipment before servicing.

 **CAUTION**

Fire Prevention

1. Install the drive on a non-combustible surface.
2. Disconnect the drive from power when the drive is damaged.
3. Do not connect a resistance directly between the DC Px and N terminals. Doing so can result in overheating and damage to the resistor.

Damage Prevention

1. Do not apply voltages higher than the values specified in this manual to any of the drive's terminals.
2. Incorrectly connecting optional equipment to the P1, P2 and N terminals can damage the drive.
3. After shutting down or disconnecting the drive, the drive may be hot to the touch.
4. Verify that the power-up restart feature is off during servicing to prevent any unexpected operation.

Other Important Precautions

It is important that the following precautions must be observed. Failure to do so can result in damage to the drive and/or personal injury.

Handling and Installation

1. The H-series drive can be heavy. Lift according to the weight of product. Use a hoist or a crane to move and install the H Series drive if necessary. Failure to do so can result in personal injury or damage to the drive.
2. Install the drive according to specifications listed within this manual.
3. Do not open the front cover while the drive is being carried or lifted.
4. Do not place heavy items on the drive.
5. The installation orientation and clearances must follow specifications listed within this manual.
6. Do not drop the drive or inflict hard impact to the drive.

Operation

1. The STOP key on the keypad can only be used to stop the drive when keypad control is enabled. Install a separate emergency stop switch if required.
2. CAUTION: When the Auto Retry function is selected the drive will restart after a fault condition occurs.
3. CAUTION: If a run signal is received, the drive will immediately restart after a fault has been manually reset. Verify run signal status before resetting any fault.
4. The operation of the drive is intended to be controlled by either keypad command or control input signals. Operation with a device (such as an inline contactor) that routinely disconnects the drive and reconnects the drive to the input supply power for the purpose of starting and stopping the motor is not recommended.
5. CAUTION: Depending on the motor specifications and ETH overload settings the motor may not be protected by the electronic thermal function of the drive.

6. The drive can be set to output a higher than line frequency output. Verify that the motor and/or connected load is capable of functioning at these higher speeds prior to operating unit.
7. The H series drive is not provided with Over Speed Protection.
8. Holding torque is not produced when using the DC-Braking function. Install separate equipment when holding torque is needed.

Fault Prevention Precautions

If necessary, install additional safety equipment, such as emergency brakes and/or interlocks to prevent uncontrolled machine operation resulting from a damaged drive.

Maintenance, Inspection, and Exchanging Components

1. Do not conduct a megger test (insulation resistance measurement) of the power or control circuitry in the drive.
2. Refer to Chapter 6 for routine inspection methods.

General Precautions

The diagrams in this manual may show the drive covers removed. Prior to operating unit, be sure to restore covers and circuit protection according to specifications.

Table of Contents

USER SELECTION GUIDE (H SERIES SPECIFICATIONS)	3
CHAPTER 1 - INSTALLATION	6
1.1 Inspection.....	6
1.2 Environmental Conditions	6
1.3 Mounting	7
1.4 Other Precautions	7
1.5 Dimensions	8
1.6 Basic Wiring	10
1.7 Power Terminals	11
1.8 Control Terminals.....	17
CHAPTER 2 - OPERATION	20
2.1 Parameter Groups	20
2.2 Display	21
2.3 Alpha-numerical Display	21
2.4 Procedure of Setting Data.....	22
2.5 Parameter Navigation	23
2.6 Operation Method	24
CHAPTER 3 - QUICK- START PROCEDURES	25
3.1 Operation Using Keypad.....	26
3.2 Operation Using Control Terminal – External Start, Stop and Speed Reference	28
3.3 Operation Using Both Keypad and Control Terminals	30
CHAPTER 4 - PARAMETER LIST	32
4.1 Drive Group.....	32
4.2 Function Group	32
4.3 I/O Group	36
CHAPTER 5 - PARAMETER DESCRIPTION	39
5.1 Drive Group [DRV].....	39
5.2 Function Group	41
5.3 I/O Group	65
CHAPTER 6 - TROUBLESHOOTING & MAINTENANCE	79
6.1 Fault Display	79
6.2 Fault Remedy.....	80
6.3 Troubleshooting	81
6.4 How to Check Power Components	86
6.5 Maintenance	87
6.6 Daily and Periodic Inspection Items.....	88

APPENDIX A - FUNCTIONS BASED ON USE ERROR! BOOKMARK NOT DEFINED.

APPENDIX B - PARAMETERS BASED ON APPLICATION .. ERROR! BOOKMARK NOT DEFINED.

DECLARATION OF CONFORMITY ERROR! BOOKMARK NOT DEFINED.

USER SELECTION GUIDE (H-SERIES SPECIFICATIONS)

200~230V Class (40 - 75HP)

Model Number		RSI-040-H-2	RSi-050-H-2	RSi-060-H-2	RSi-075-H-2
Motor Rating ¹	Constant Torque [HP]	40	50	60	75
	Constant Torque [kW]	30	37	45	55
Output Ratings	Constant Torque [kVA] ²	46	55	68	83
	Constant Torque FLA [A]	122	146	180	220
Input Ratings	Input Voltage	3 Phase, 200 to 230 V (± 10%)			
	Input Frequency	50 to 60 Hz (± 5%)			
Weight [kg (lbs)]		42 (93)	42 (93)	56 (123)	56 (123)

¹ Indicates the maximum applicable capacity when using a 4 Pole motor.

² Rated kVA ($\sqrt{3} \cdot V \cdot I$) listed is based on 220VAC operation.

440~460V Class (40 - 100HP)

Model Number		RSi-040-H-4-L	RSi-050-H-4-L	RSi-060-H-4-L	RSi-075-H-4-L	RSi-100-H-4-L
Motor Rating ³	Constant Torque [HP]	40	50	60	75	100
	Constant Torque [kW]	30	37	45	55	75
	Variable Torque [HP]	50	60	75	100	125
	Variable Torque [kW]	37	45	55	75	90
Output Ratings	Constant Torque FLA [A]	61	75	91	110	152
	Constant Torque [kVA] ⁴	45	56	68	82	113
	Variable Torque FLA [A]	80	96	115	125	160
	Variable Torque [kVA] ⁵	60	70	86	93	120
Input Ratings	Input Voltage	3 Phase, 440 to 460 V (± 10%)				
	Input Frequency	50 to 60 Hz (± 5%)				
Weight [kg (lbs)]		45 (99)	45 (99)	63 (139)	63 (139)	68 (150)

440~460V Class (125 - 300HP)

Model Number		RSi-125-H-4-L	RSi-150-H-4-L	RSi-200-H-L	RSi-250-H-4-L	RSi-300-H-4-L
Motor Rating ⁴	Constant Torque [HP]	125	150	200	250	300
	Constant Torque [kW]	90	110	132	160	220
	Variable Torque [HP]	150	200	250	300	400
	Variable Torque [kW]	110	132	185	220	280
Output Ratings	Constant Torque FLA [A]	183	223	264	325	432
	Constant Torque [kVA] ⁵	136	166	197	242	322
	Variable Torque FLA [A]	228	264	330	361	477
	Variable Torque [kVA] ⁵	170	200	246	270	356
Input Ratings	Input Voltage	3 Phase, 440 to 460 V (± 10%)				
	Input Frequency	50 to 60 Hz (± 5%)				
Weight [kg (lbs)]		98 (216)	98 (216)	122 (269)	122 (269)	175 (386)

³ Indicates the maximum applicable capacity when using a 4 Pole motor.

⁴ Rated kVA ($\sqrt{3} \cdot V \cdot I$) listed is based on 440VAC operation.

All Models

Output Ratings	Max. Frequency	0.5 to 400 Hz
	Output Voltage	3 Phase, 0 to Input Voltage
Control	Control Method	Space Vector PWM
	Frequency Setting Resolution	Digital Reference: 0.01 Hz (Below 100Hz), 0.1 Hz (Over 100Hz) Analog Reference: 0.03 Hz / 60Hz
	Frequency Accuracy	Digital: 0.01% of Maximum Output Frequency Analog: 0.1% of Maximum Output Frequency
	V/F Ratio	Linear, Non-Linear, User Programmable
	Braking Torque (w/o DB)	About 20%
	Overload Capacity CT	150% of Rated Current for 1 Minute, 200% for 0.5 Second
	Overload Capacity VT	110% of Rated Current for 1 Minute, 150% for 0.5 Second
	Torque Boost	Manual Torque Boost (0 to 20%), Auto Torque Boost
Operating	Operation Method	Keypad / Terminal / Remote (Optional)
	Frequency Setting	Analog: 0 to 10 V / 4 to 20mA, Digital: Keypad
	Accel / Decel Time	0.1 to 6,000 sec, 8 Pre-Defined (Programmable)
	Multi-Step	8 Preset Operational Speed
	Jog	Jog Operation
	Operating Function	DC Braking, Frequency Limit, Frequency Jump, Slip Compensation, PI Control, Stall Prevention
	Operating Status	Frequency Detection Level, Overload Alarm, Stalling, Over Voltage, Under Voltage, Inverter Overheat, Run, Stop, Constant Speed, Speed Searching
	Start Signal	Forward, Reverse
Programmable I/O	Programmable Input	6 Programmable Inputs
	Programmable Output	5 Programmable Outputs: 2 Form A Contact (N.O.) Fault Contact Output (A, C, B) – 250VAC 1A, 30VDC 1A 3 Open Collector Outputs: 24V, 50mA
	Analog	4 ~ 20mA
	Meter	RPM, Hz, Current, Voltage (Output Pulse: 500Hz, Output Voltage: 0 ~ 10V)
Protective Functions	Inverter Trip	Over Voltage, Under Voltage, Over Current, Inverter Overload, Fuse Open, Ground Fault, Inverter Overheat, Motor Overheat, Main CPU Error.
	Stall Prevention	Over Current Prevention
	Instant Power Loss	Less Than 15msec: Continuous Operation More Than 15msec: Auto Restart (Programmable)
Operating Conditions	Ambient Temp.	14 °F ~ 104 °F (-10 °C ~ 40 °C), <i>CE Certification: 41 °F ~ 104 °F (5 °C ~ 40 °C)</i>
	Storage Temp.	-4 °F ~ 149 °F (-20 °C ~ 65 °C)
	Humidity	90% RH Max. (Non-Condensing), <i>CE Certification: 5 ~85% (Non-Condensing)</i>
	Altitude / Vibration	Below 3,300ft (1,000m) / Below 5.9m/sec ² (0.6g)
	Air Pressure	86 ~ 106kPa
	Application Site	No Corrosive Gas, Combustible Gas, Oil Mist, or Dust
	Cooling Method	Forced Air Cooling
Enclosure	IP00	
Inter National Standards	CE Certified, UL Listed (UL508C) ⁵	

⁵ UL508C: UL Standard for Safety for Power Conversion Equipment. UL File E124949. UL listing is available only for 380~460V Class drives.

CHAPTER 1 - INSTALLATION

1.1 Inspection

- ✓ Inspect the drive for any damage that may have occurred during shipping.
- ✓ Check the nameplate on the drive. Verify the drive unit is the correct one for the application. The numbering system for the Benshaw drive is as shown below.

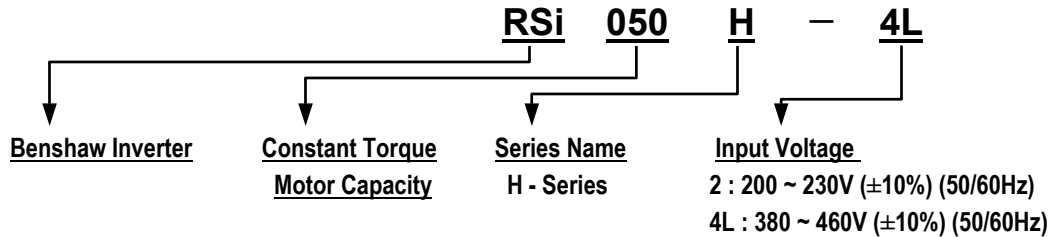

1.2 Environmental Conditions

- ✓ Verify the ambient air conditions at the mounting location.
 - The ambient temperature should not be below 14°F (-10°C) or above 104°F (40°C).
 - The relative humidity should be less than 90% (non-condensing).
 - The drive is rated for operation up to 3,300ft (1,000m) above sea level. Derate drive 1% for every 330ft (100m) above 3,300ft (1000m).
- ✓ Do not mount the drive in direct sunlight or near other heat sources.
- ✓ The drive shall be located in a Pollution Class 2 environment. If the drive is going to be installed in an environment with a high probability of dust, metallic particles, mists, corrosive gasses, or other contaminants, the drive must be located inside the appropriate electrical enclosure of the proper NEMA rating or IP degree.
- ✓ Do not mount the drive in a location where excessive vibration is present such as installing the drive on a press or other moving equipment.

1.3 Mounting

- ✓ The drive must be mounted vertically with sufficient horizontal and vertical space between adjacent equipment (A= Over 20" (500mm), B= Over 8" (200mm)).

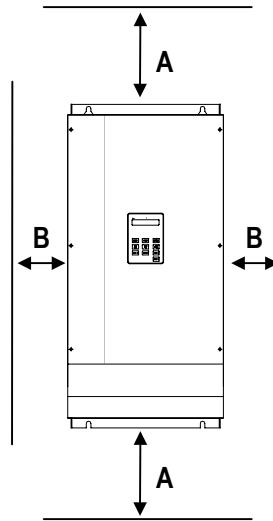

1.4 Other Precautions

- ✓ Do not carry the drive by the front cover.
- ✓ When installing the drive inside a panel or cabinet with multiple drives or ventilation fans consult the figures below. If installed incorrectly, the ambient temperature inside the cabinet may exceed specified limits.

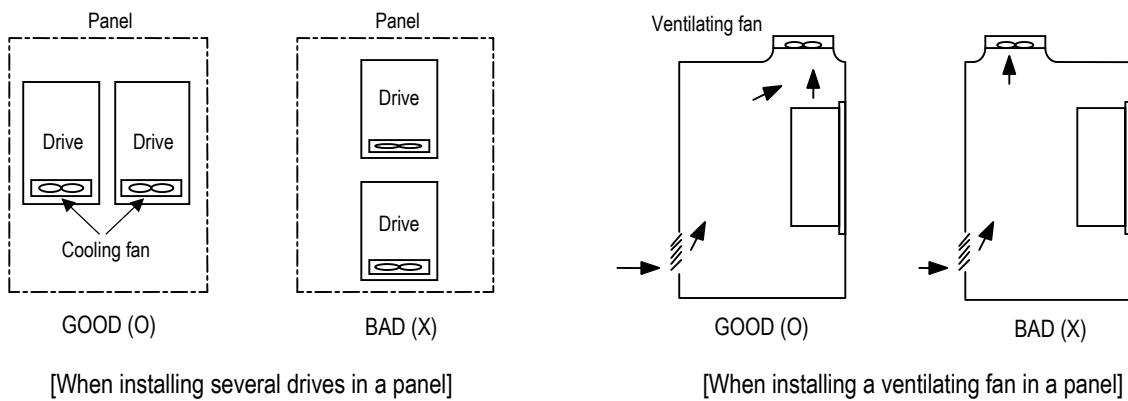

- ✓ Install the drive to its mounting panel using appropriately sized screws or bolts to insure the drive is firmly fastened.

1.5 Dimensions

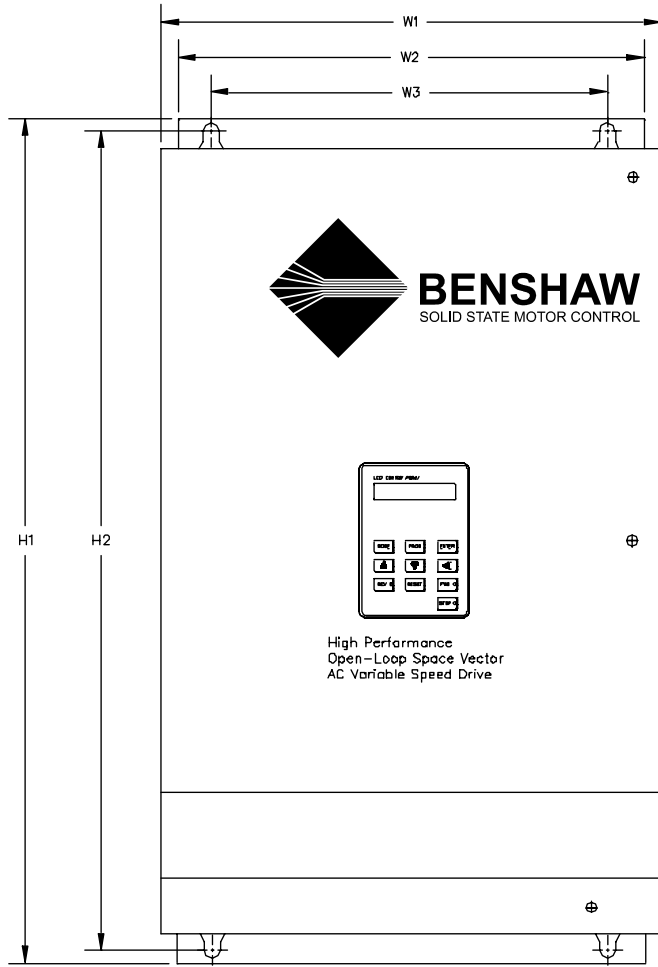

FRONT VIEW



SIDE VIEW

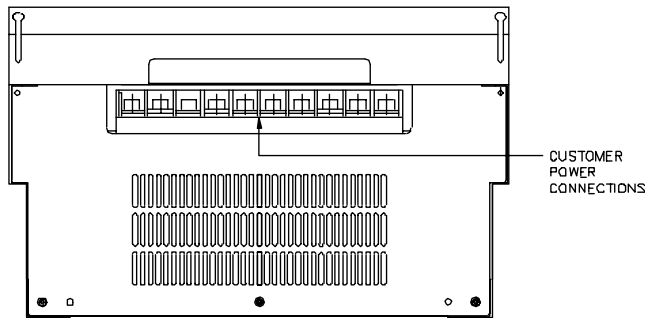

BOTTOM VIEW

Dimensions (millimeters)

Model No.	W1	W2	W3	H1	H2	D1	D2	D3
RSi-040-H-2	375	360	275	615	593.5	277.5	265.5	230.5
RSi-050-H-2	375	360	275	615	593.5	277.5	265.5	230.5
RSi-060-H-2	375	360	275	780	758.5	300.7	281.7	230.5
RSi-075-H-2	375	360	275	780	758.5	300.7	281.7	230.5
RSi-040-H-4	350	319.2	270	680	660	306.6	289.2	236.4
RSi-040-H-4-L	350	319.2	270	680	660	308.2	-	255.5
RSi-050-H-4	450	420	356.8	760	736.5	304.2	288.4	245.2
RSi-050-H-4-L	350	319.2	270	680	660	308.2	-	255.5
RSi-060-H-4	450	420	356.8	760	736.5	304.2	288.4	245.2
RSi-060-H-4-L	375	360	275	780	758.5	301	-	234
RSi-075-H-4	450	420	356.8	760	736.5	304.2	288.4	245.2
RSi-075-H-4-L	375	360	275	780	758.5	301	-	234
RSi-100-H-4	375	360	275	780	758.5	300.7	281.7	230.5
RSi-100-H-4-L	375	360	275	780	758.5	325	-	234
RSi-125-H-4	530	507	430	780	760	320.3	292	232
RSi-125-H-4-L	530	507	430	780	760	335	-	286.2
RSi-150-H-4	530	507	430	780	760	320.3	292	232
RSi-150-H-4-L	530	507	430	780	760	335	-	286.2
RSi-200-H-4	530	507	430	1000	980	352	331	253
RSi-200-H-4-L	530	507	430	1000	980	345	-	298
RSi-250-H-4	530	507	430	1000	980	352	331	253
RSi-250-H-4-L	530	507	430	1000	980	345	-	298
RSi-300-H-4	680	642	540	1002	969	400	-	355
RSi-300-H-4-L	680	642	540	1002	969	400	-	355

Dimensions (inches)

Model No.	W1	W2	W3	H1	H2	D1	D2	D3
RSi-040-H-2	14.76	14.17	10.83	24.21	23.37	10.93	10.45	9.07
RSi-050-H-2	14.76	14.17	10.83	24.21	23.37	10.93	10.45	9.07
RSi-060-H-2	14.76	14.17	10.83	30.71	29.86	11.84	11.09	9.07
RSi-075-H-2	14.76	14.17	10.83	30.71	29.86	11.84	11.09	9.07
RSi-040-H-4	13.78	12.57	10.63	26.77	25.98	12.07	11.39	9.31
RSi-040-H-4-L	13.78	12.57	10.63	26.77	25.98	12.13	-	10.06
RSi-050-H-4	17.72	16.54	14.05	29.92	29.00	11.98	11.35	9.65
RSi-050-H-4-L	13.78	12.57	10.63	26.77	25.98	12.13	-	10.06
RSi-060-H-4	17.72	16.54	14.05	29.92	29.00	11.98	11.35	9.65
RSi-060-H-4-L	14.76	14.17	10.83	30.71	29.86	11.85	-	9.21
RSi-075-H-4	17.72	16.54	14.05	29.92	29.00	11.98	11.35	9.65
RSi-075-H-4-L	14.76	14.17	10.83	30.71	29.86	11.85	-	9.21
RSi-100-H-4	14.76	14.17	10.83	30.71	29.86	11.83	11.09	9.07
RSi-100-H-4-L	14.76	14.17	10.83	30.71	29.86	12.80	-	9.21
RSi-125-H-4	20.83	19.96	16.93	30.71	29.92	12.61	11.50	9.13
RSi-125-H-4-L	20.83	19.96	16.93	30.71	29.92	13.19	-	11.27
RSi-150-H-4	20.83	19.96	16.93	30.71	29.92	12.61	11.50	9.13
RSi-150-H-4-L	20.83	19.96	16.93	30.71	29.92	13.19	-	11.27
RSi-200-H-4	20.87	19.96	16.93	39.37	38.58	13.86	13.03	9.96
RSi-200-H-4-L	20.87	19.96	16.93	39.37	38.58	13.58	-	11.73
RSi-250-H-4	20.87	19.96	16.93	39.37	38.58	13.86	13.03	9.96
RSi-250-H-4-L	20.87	19.96	16.93	39.37	38.58	13.58	-	11.73
RSi-300-H-4	26.77	25.28	21.25	39.45	38.15	15.75	-	13.98
RSi-300-H-4-L	26.77	25.28	21.25	39.45	38.15	15.75	-	13.98

1.6 Basic Wiring

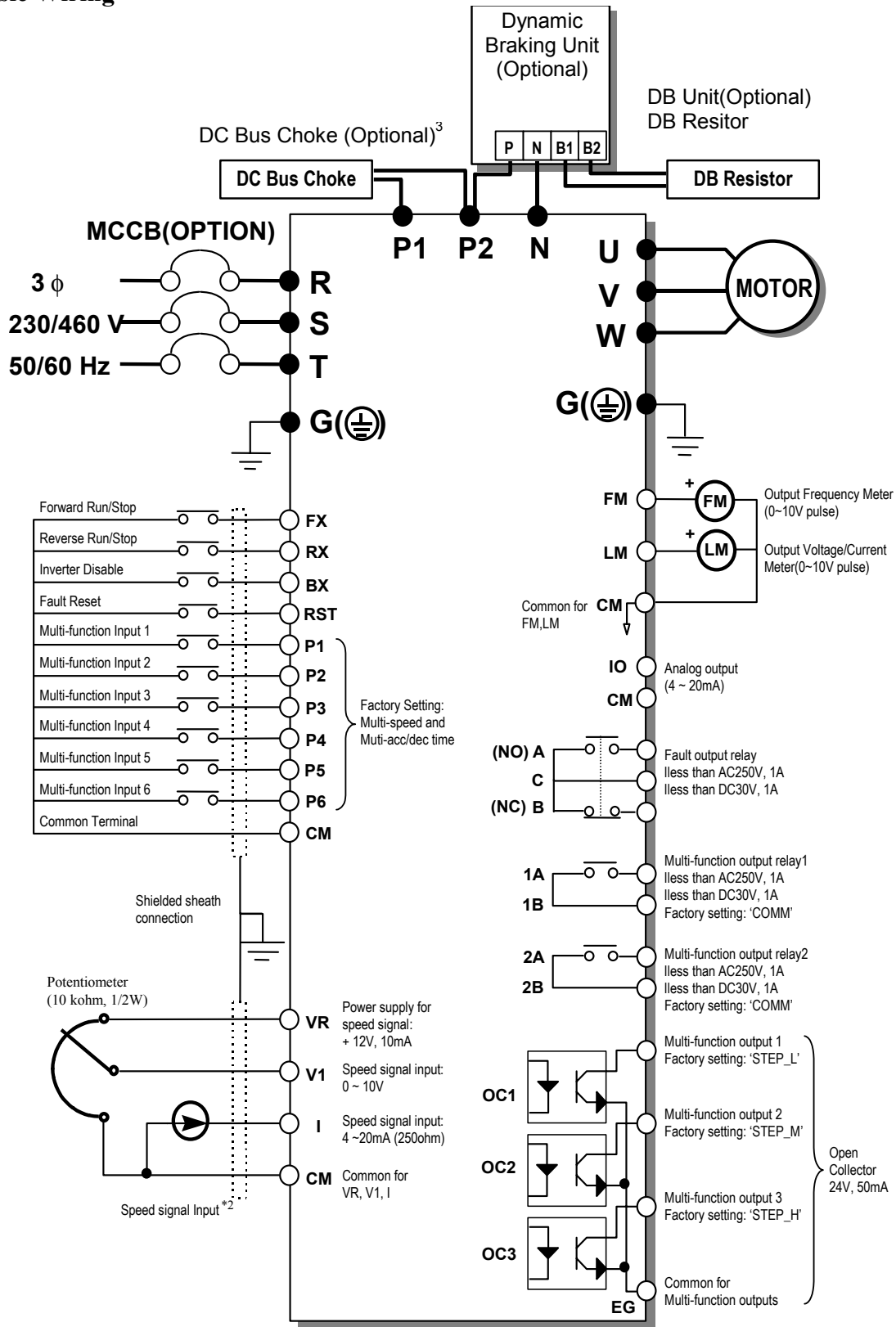

Note) ● Main Circuit Terminals ○ Control Circuit Terminals.

1. Analog speed command may be set by Voltage, Current or both..
2. When installing the DC Reactor, the Common Busbar between P1 and P2 must be removed.

1.7 Input Power

- The installation of the H-Series drive must comply with all national and local electrical codes regarding wiring, grounding, branch circuit protection and disconnect devices.
- The H-Series drive is designed to operate with a three-phase input with symmetrical/balanced input voltages. Consult factory for operation with other input configurations.
- A supply voltage above or below the limits given in the specifications can cause the drive to trip either with an undervoltage or overvoltage condition.
- The H-Series drives can usually be directly connected to an AC supply of the correct voltage level. However an AC input reactor and/or DC bus choke is recommended for installations where the input supply source kVA rating is greater than six (6) times the kVA rating of the drive.
- If the AC source supplying the drive has power factor correction capacitors connected to it, it is recommended that an AC input reactor be installed between the capacitor bank and the drive. Otherwise the power factor capacitors may be damaged.
- The H-Series drives are suitable for use on an input supply circuit capable of delivering not more than the following symmetrical RMS current at 264VAC max. for 230V rated units and 506VAC max. for 460V rated units:

Model Number	Circuit Current Capability
RSi-040-H-2, 050-H-2, 060-H-2, 075-H-2,	10,000 Amps RMS
RSi-040-H-4, 050-H-4, 060-H-4, 075-H-4, 100-H-4, 125-H-4, 150-H-4, 200-H-4, 250-H-4	65,000 Amps RMS
RSi-300-H-4	18,000 Amps RMS

1.8 Power Terminals

- **Type A Configuration: 230V Class** (RSi-040-H-2, RSi-050-H-2, RSi-060-H-2, RSi-075-H-2)

R	S	T	G	U	V	W	G	P1	P2	N
----------	----------	----------	----------	----------	----------	----------	----------	-----------	-----------	----------

Type B Configuration: 380 ~ 460V Class (RSi-040-H-4-L through RSi-300-H-4-L)

R	S	T	G	U	V	W	P1	P2	N
----------	----------	----------	----------	----------	----------	----------	-----------	-----------	----------

Symbols	Functions
R	AC Line Voltage Input

S	(3 Phase, 200 ~ 230VAC or 380 ~ 460VAC)
T	
G	Earth Ground
P1	<i>Positive DC Bus Terminal</i> External DC Reactor (P1-P2) and DB Unit (P2-P1) Connection Terminals
P2	
N	<i>Negative DC Bus Terminal</i> DB Unit (N-N ¹) Connection Terminal
U	3-Phase Power Output Terminals to Motor (3 Phase, 200 ~ 230VAC or 380 ~ 460VAC)
V	
W	

1.8.1 Input and Motor Power Wiring

- The input power and motor cables must be of the appropriate type and dimensioned according to applicable national and local (NEC, etc.) regulations to carry the rated current of the drive. It is recommended that the cables be at least the size listed in the following table.

Model Number	Terminals (R, S, T, U, V, W)		Model Number	Terminals (R, S, T, U, V, W)	
	Wire Size (mm ²)	Wire Size (AWG)		Wire Size (mm ²)	Wire Size (AWG)
RSi-040-H-2	60	1/0	RSi-075-H-4-L	38	2
RSi-050-H-2	60	1/0	RSi-100-H-4-L	60	1/0
RSi-060-H-2	100	4/0	RSi-125-H-4-L	60	1/0
RSi-075-H-2	100	4/0	RSi-150-H-4-L	80	3/0
RSi-040-H-4-L	22	4	RSi-200-H-4-L	100	4/0
RSi-050-H-4-L	22	4	RSi-250-H-4-L	100	4/0
RSi-060-H-4-L	38	2	RSi-300-H-4-L	100 ×2	4/0 ×2

- Use at least 60C temperature rated copper (Cu) wire for all power connections.
- To reduce the coupling of electrical noise, do not run power wiring in the same conduit or raceway as the control wiring
- The following is the supplied bolt size and maximum lug width that can be used to connect to the power terminals of the drive.

Model Number	Bolt Size	Maximum Lug Width
RSi-040-H-2,050-H-2, 040-H-4, 050-H-4	M8 (~ 5/16" dia.)	22mm (0.865")
RSi-060-H-2,075-H-2, 060-H-4, 075-H-4, 100-H-4	M8	22mm (0.865")

¹ This N terminal is provided on optional Dynamic Braking Unit. (Refer to DB Unit Manual for detail terminal configuration)

RSi-125-H-4, 150-H-4	M10 (~ 13/32" dia.)	30mm (1.180")
RSi-200-H-4, 250-H-4	M10	42.50mm (1.675")
RSi-300-H-4	M10	48.25mm (1.900")

- The recommended tightening torque for the power terminals are as follows:

Model Number	Recommended Power Terminals Tightening Torque
RSi-040-H-2,050-H-2, 040-H-4, 050-H-4	150 in. - lb. (12.5 ft. - lb.)
RSi-060-H-2,075-H-2, 060-H-4, 075-H-4, 100-H-4	150 in. - lb. (12.5 ft. - lb.)
RSi-125-H-4, 150-H-4	350 in. - lb. (29 ft. - lb.)
RSi-200-H-4, 250-H-4, 300-H-4	450 in. - lb. (37.5 ft. - lb.)

- Installations with long motor cable lengths may require the addition of output reactors and/or cable terminators to limit the level of voltage reflections at the motor. Depending on the length of the motor cables and the type of cable used, the reflected voltage may degrade the motor insulation and damage the motor. Use of an inverter duty motor is recommended. Contact the factory for more information.

1.8.2 Power Terminal Configuration

A Dynamic Braking Unit or a DC Bus Choke or both of them may be added to an H Series drive.

 **Jumper Between P1 and P2 Must Be Removed In Order To Install a DC Bus Choke.**

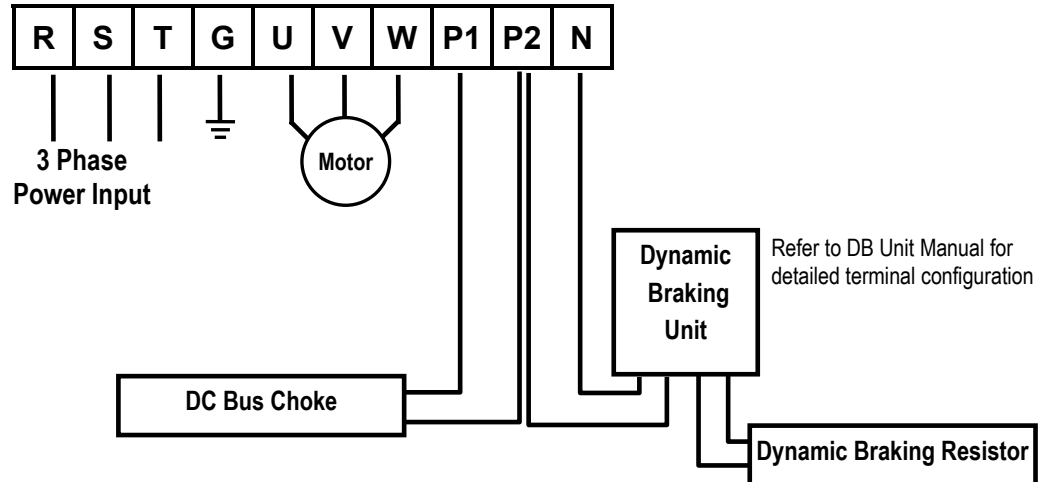

Fig. 1 – Type C Dynamic Braking Unit, DC Bus Choke Installation

WARNING

Normal stray capacitance between the inverter and chassis can provide a high impedance shock hazard. Refrain from applying power to the inverter if the inverter frame (Power terminal G) is not grounded.

1.8.3 Wiring Power Terminals

■ **Wiring Precautions**

- ✓ The internal circuits of the drive will be damaged if the incoming power is connected and applied to the output terminals (U, V, W). If a drive bypass contactor is used, extreme care must be taken so that input voltage is never applied to the motor terminals.
- ✓ Use ring terminals with insulated caps when wiring the input power and motor wiring.
- ✓ Do not leave wire fragments inside the drive. Wire fragments can cause a short circuit and cause serious damage to the drive.
- ✓ Do not use 3-wire cable (multiconductor) power cable for long distances. Due to the increased leakage capacitance between the wires, the H Series drive over-current protective feature may operate or the equipment connected to the output may malfunction.
- ✓ The main circuits of the drive may produce high frequency noise and can hinder communication equipment located near the drive. To reduce noise, install line noise filters on the input side of the drive.
- ✓ Do not use power factor capacitor, surge arrestors, or RFI filters on the output or motor side of the drive. Doing so may damage the drive and/or the additional components.
- ✓ Always check whether the LCD display and the charge lamp (LED) are OFF before wiring terminals. The DC bus capacitors may hold a high-voltage even after the power is disconnected. Use caution to prevent the possibility of personal injury.

■ **Grounding**

- ✓ The drive contains high power and high frequency switching devices, leakage current may flow between the drive components and ground. Ground the drive to avoid electrical shock.
- ✓ Connect only to the dedicated ground terminal of the drive. Do not use the case or chassis screws for grounding.
- ✓ The protective earth conductor must be the first one connected and the last one disconnected when connecting power wiring to and from the drive.
- ✓ The grounding wire shall comply with all local regulations. It is recommend that it be at least the size listed in the following table and be as short as possible.

Motor Capacity	Grounding wire dimensions, AWG (mm ²)	
	200V Class	400Vclass
30 ~ 37kW	4 (22)	6 (14)
45 ~ 75kW	2 (38)	4 (22)
90 ~ 132kW	-	2 (38)
160 ~ 280kW	-	1/0 (60)

■ Power and Motor Connection

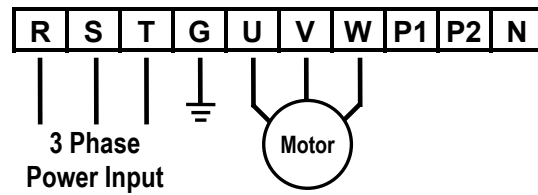

Power supply must be connected to the R, S, and T terminals.

Connecting it to the motor (U, V, and W) terminals will cause internal damage to the drive. Arranging the phase sequence is not necessary.



Motor should be connected to the U, V, and W terminals.

If the forward command (FX) is on, the motor should rotate counter clockwise when viewed from the load side of the motor. If the motor rotates in the reverse, switch the U and V terminals.

1.9 Control Terminals

1A	1B	2A	2B	OC1	OC2	EG	RST	FX	RX	BX	CM	VR	V1	V2	IO
A	C	B	OC3	CM	P1	P2	P3	P4	P5	P6	CM	I	FM	LM	CM

Type	Symbol	Name	Description
Input signal	Starting Contact Function Select	P1 ~ P6	Multi-Function input 1 ~ 6 Used for Multi-Function Input Terminal.
		FX	Forward Run Command Forward Run When Closed and Stopped When Open.
		RX	Reverse Run Command Reverse Run When Closed and Stopped When Open.
		BX	Emergency Stop When the BX Signal is ON the Output of the Drive is Turned Off. When Motor uses an Electrical Brake to Stop, BX is used to Turn Off the Output Signal. When BX Signal is OFF (Not Turned Off by Latching) and FX Signal (or RX Signal) is ON, Motor continues to Run.
		RST	Fault Reset Used for Fault Reset.
		CM	Sequence Common Common Terminal for Contact Inputs.
	Analog Frequency Setting	VR	Frequency Setting Power (+10V) Used as Power for Analog Frequency Setting. Maximum Output is +12V, 10mA.
		V1 V2	Frequency Reference (Voltage) Used for 0-10V Input Frequency Reference. Input Resistance is 20 K Ω
		I	Frequency Reference (Current) Used for 4-20mA Input Frequency Reference. Input Resistance is 250 Ω
		CM	Frequency Setting Common Terminal Common Terminal for Analog Frequency Setting
Output signal	Pulse	FM	Frequency Output (For External Monitoring) Outputs PWM signal according to drive Output Frequency. Maximum Output Voltage and Output Current are 0-12V and 1mA.
		LM	Current/Voltage Output (For External Monitoring) Outputs One of the Following: Output Current, Output Voltage. Default is set to Output Voltage. Maximum Output Voltage and Output Current are 0-12V and 1mA. Output Frequency is Set at 1.8kHz.
	Analog	IO	Frequency Output (4 ~ 2-mA) Outputs Analog Signal according to drive Output Frequency.
	Contact	A, C, B	Fault Output Relay Activates when Protective Function is Operating. AC250V, 1A or less; DC30V, 1A or less. Fault: 30A-30C Closed (30B-30C Open) Normal: 30B-30C Closed (30A-30C Open)
		1A-1B, 2A-2B	Multi-Function Output Relay 1 and 2 (AUX1, AUX2) Use after Defining Multi-Function Output Terminal. AC250V, 1A or less; DC30V, 1A or less.
		CO1, OC2, OC3	Multi-Function Open Collector Output Use after Defining Multi-Function Output Terminal. DC24V, 50mA
		EG	Multi-Function Open Collector Output Common Terminal Ground Terminal for OC1, OC2, OC3.

1.9.1 Wiring Control Terminals

■ Wiring Precautions

- ✓ Use at least 60C temperature rated copper (Cu) wire of 18-26AWG for all control circuit, auxiliary outputs (1A, 1B, 2A, 2B), and fault output (A, B, C).
- ✓ The control terminal recommended tightening torque is 5.2 in-lbs.
- ✓ The use of shielded wires or twisted wires for control circuit wiring is recommended to reduce noise pickup.
- ✓ Separate control wires as much as possible from the main power circuits and other high voltage circuits.
- ✓ Separate Class 1 (low voltage) control wires from Class 2 (120/240VAC) control signals. Do not mix Class 1 and Class 2 signals in the same cable.

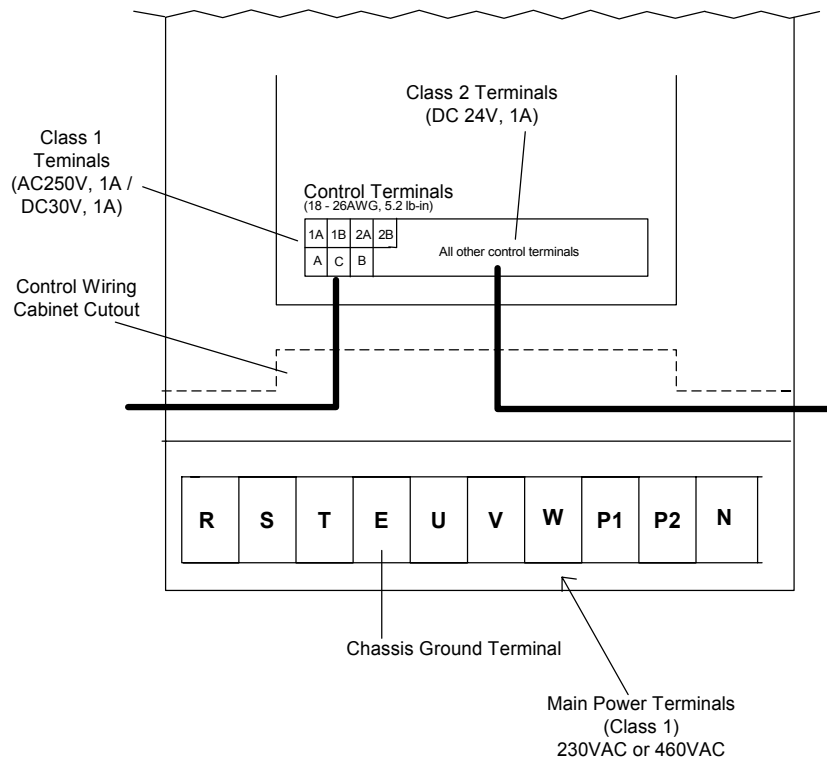

- ✓ Wire rated for Class 2 usage (300V) or higher shall be used for ALL control wiring connections.
- ✓ The CM and EG control terminals are isolated from each other. Do not connect these terminals together and do not connect these terminals to the power ground.

■ Control Circuit Terminal

The control input terminal of the control circuit is ON when the current flows out of the terminal, as shown in the following illustration. CM terminal is the common terminal for the contact input signals.

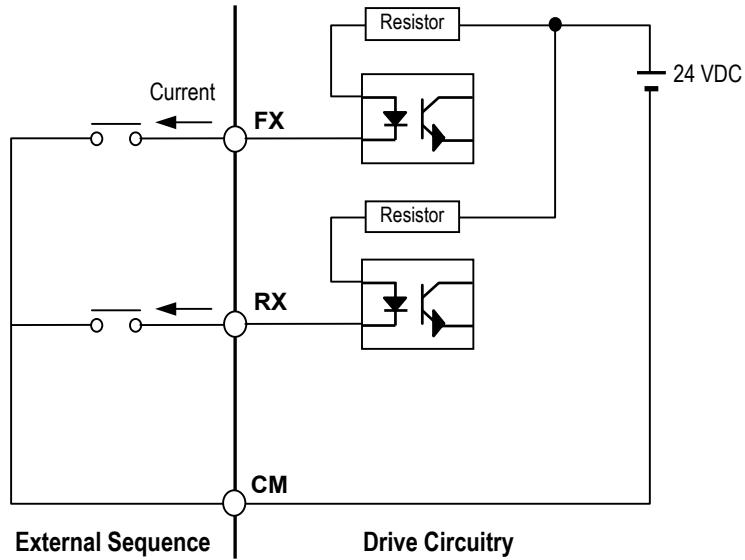

CAUTION

Do not apply external voltage to any of the control input terminals (FX, RX, P1~P6, BX, RST, FM, LM, IO, CM Etc). Otherwise damage to the inputs may result.

CHAPTER 2 - OPERATION

The H series inverter has three parameter groups separated according to their function, as indicated in the following table.

2.1 Parameter Groups

Group	LCD Keypad (Upper Left Corner)	Description
Drive Group	DRV	Command Frequency, Accel/Decel Time Etc. Basic Parameters
Function Group	FUN	Maximum Frequency, Amount of Torque Boost, Etc. Basic Related Parameters
Input/Output Group	I/O	Multi-Function Terminal Settings. Parameters Needed for Sequence Operation

Refer to the function descriptions in Chapter 5 for detailed description of each group.

2.2 Display

The LCD keypad can display up to 32 alphanumeric characters. Various settings can be checked directly from the display. The keypad is fully upload and download capable. The following is an illustration of the keypad

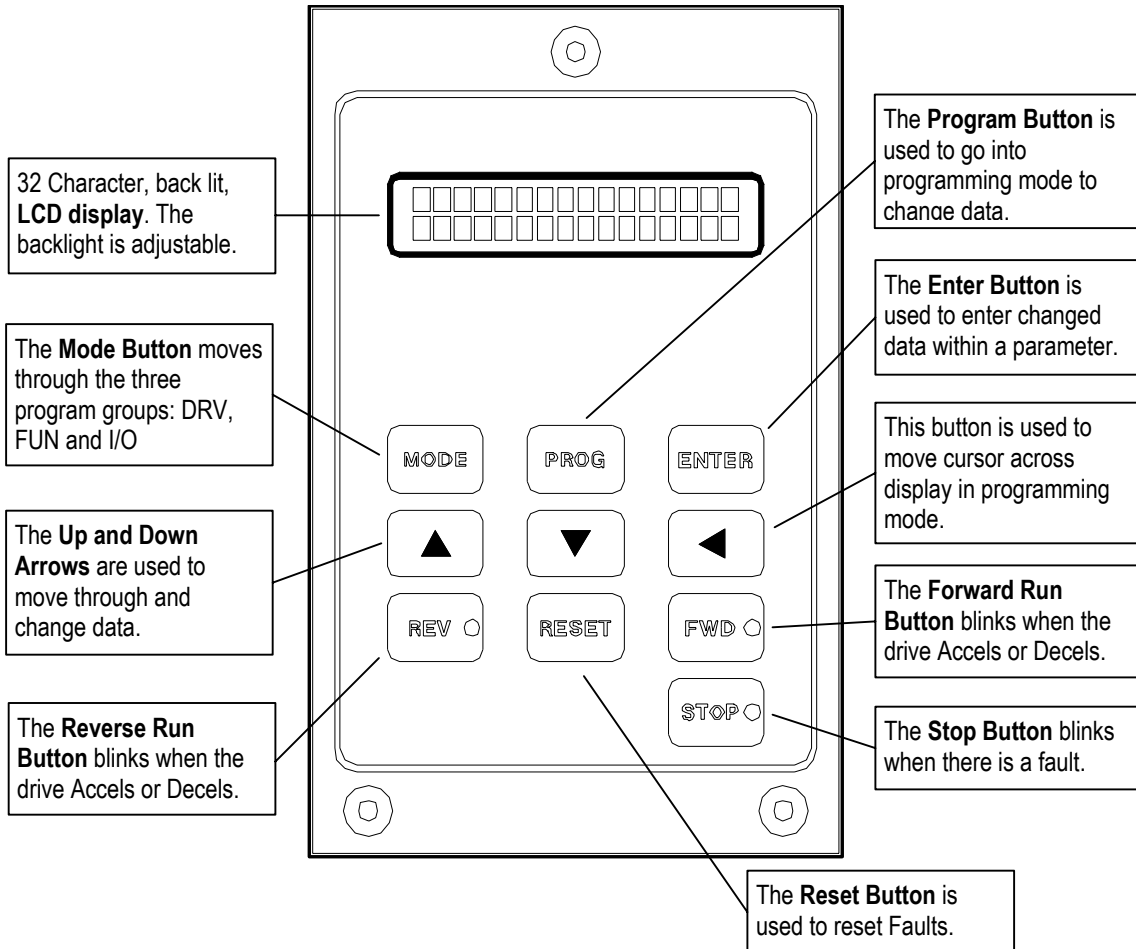



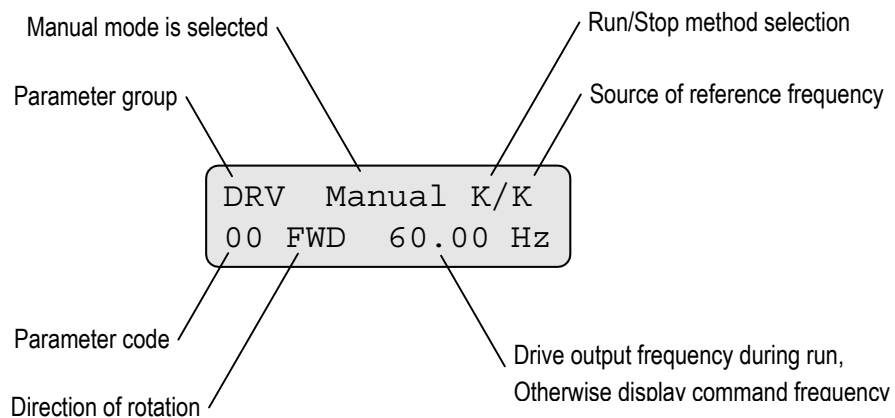





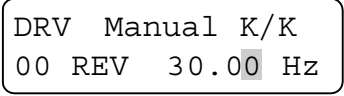
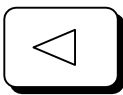
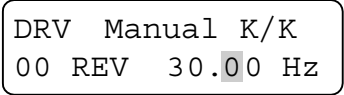

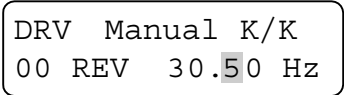
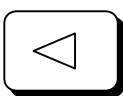
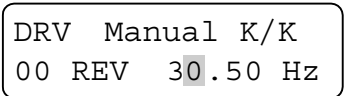
2.3 Alpha-numerical Display

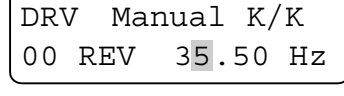
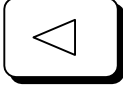
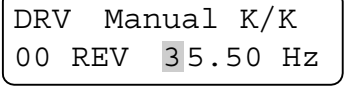

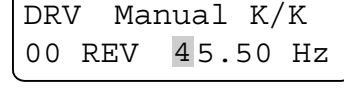
2.4 Procedure of Setting Data

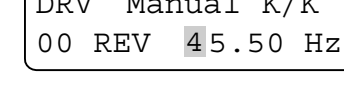
To change command frequency from 30.00Hz to 45.50Hz:

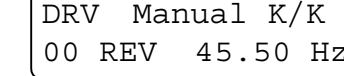
		Press PROG key and the cursor appears on the lowest digit.
		Press LEFT key once to move digit.
		Press UP key 5 times.
		Press SHIFT key once to shift the cursor to next digit.
		Press UP key 5 times.
		Press SHIFT key once to shift the cursor to next digit.
		Press UP key once to make 4.
		Press ENTER key to store new value.
		

The same procedure is applied to all other parameters. While the drive is running, the output frequency can be changed to a new command frequency.

- **Note:** Some parameters cannot be changed while the inverter is running (refer to the function table in Chapter 4)

2.5 Parameter Navigation

In any of the parameter groups, users may jump to a specific parameter code by following these steps:

- Select a parameter group that requires a change.
- At the beginning of each program group the menu will read [Jump Code]. Press the [PROG] key. Enter the code number of the parameter needing to be changed, then press [ENTER] key. There is no jump code for [Drive Group].

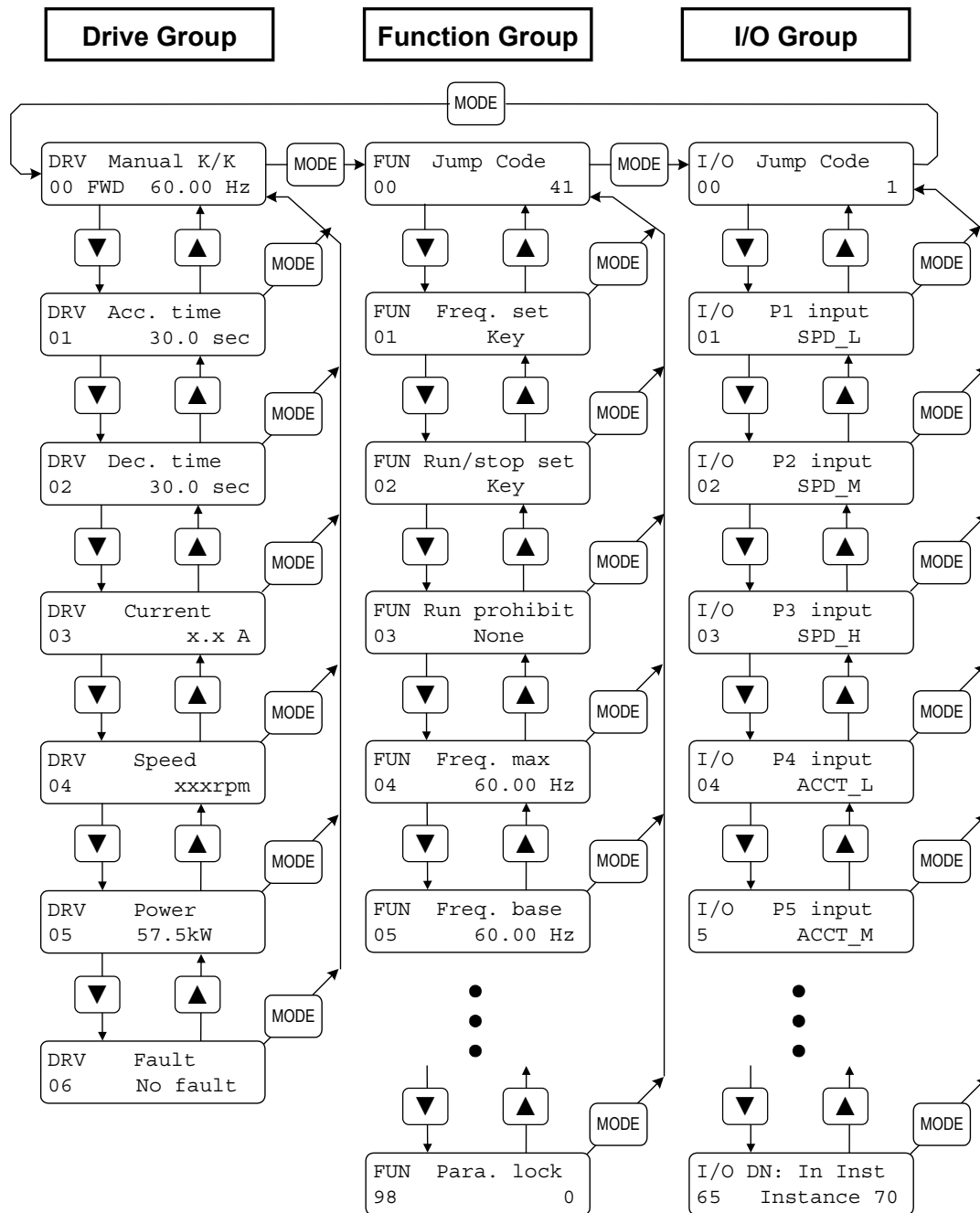

2.6 Operation Method

The H Series has several operation methods as shown below.

Operation Method	Function	Function Setting
Operation using keypad	Run/Stop command and frequency are set only through the keypad.	FUN 01: Key FUN 02: Key
Operation using Control Terminals	Closing FX or RX terminal performs Run/Stop. Frequency reference is set through V1 or I terminal.	FUN 01: Terminal FUN 02: Terminal-1 or Terminal-2
Operation using both Keypad and Control Terminals	Run/Stop is performed by the keypad. Frequency reference is set through the V1 or I terminal.	FUN 01: Terminal FUN 02: Key
	Closing FX or RX terminal performs Run/Stop. Frequency reference is set through the keypad.	FUN 01: Key FUN 02: Terminal-1 or Terminal-2
Option	Operation using RS485 communication between inverter and computer.	FUN 01: Remote FUN 02: Remote I/O 48: RS485
	Operation using ModBus RTU communication between inverter and PLC.	FUN 01: Remote FUN 02: Remote I/O 48: ModBus RTU
	Operation using FNet communication between inverter and computer.	FUN 01: Remote FUN 02: Remote I/O 48: Fnet
	Operation using Device Net communication between inverter and computer.	FUN 01: Remote FUN 02: Remote I/O 48: Device Net

CHAPTER 3 QUICK- START PROCEDURES

These Quick-Start Up instructions are for those applications where:

- The user wants to get the H Series inverter started quickly
- The factory-preset values are suitable for the user application

The factory-preset values are shown on the 'Chapter 4 - Parameter List'. The H Series inverter is configured to operate a motor at 60Hz (base frequency). If the application requires coordinated control with other controllers, it is recommended the user become familiar with all parameters and features of the inverter before applying AC power.

1. Mounting the inverter (mount the inverter as described in '1.3 Mounting')
 - Install in a clean, dry location
 - Allow a sufficient clearance around top and sides of inverter
 - The ambient temperature should not exceed 40°C (104°F)
 - If two or more inverters are installed in an enclosure, add additional cooling
2. Wiring the inverter (connect wiring as described in '1.7 Power Terminals')
 - AC power should be turned OFF
 - Verify the AC power matches the nameplate voltage of the drive

3.1 Operation Using Keypad

1. Apply AC power.

2. If the message of DRV 00 is 'Manual K/K', go to step 11.

```
DRV Manual K/K
00 FWD  0.00 Hz
```

3. Press the [PROG] key to display function group.

```
MODE
FUN Jump code
00                               41
```

4. Press the UP-arrow key to display FUN 01.

```
△
FUN Freq. set
01   Terminal
```

5. Press the [PROG] key to enter into the program mode.

```
PROG
FUN Freq. set
01   Terminal █
```

6. Using arrow keys, select 'Key', then press the [ENTER] key.

```
△
FUN Freq. set
01   Key █
```

```
ENTER
```

7. Press UP-arrow key to display FUN 02.

```
△
FUN Run/stop set
02   Terminal-1
```

8. Press [PROG] key to enter into the program mode.

```
PROG
FUN Run/stop set
02   Terminal-1 █
```

9. Using arrow keys, select 'Key', then press the [ENTER] key.

```
△
FUN Run/stop set
02   Key █
```

```
ENTER
```

10. Press the [MODE] key repeatedly until DRV 00 is displayed.

```
MODE
DRV Manual K/K
00 FWD  0.00 Hz
```

11. Set the frequency reference by pressing the [PROG] key. Using arrow keys, change the data to 5.00 Hz. Press the [ENTER] key.

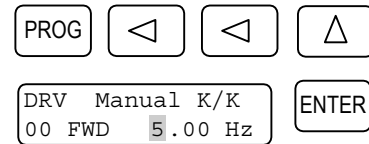

12. Press UP-arrow key to display DRV 01. Change the acceleration time by pressing the [PROG], arrow and [ENTER] keys.

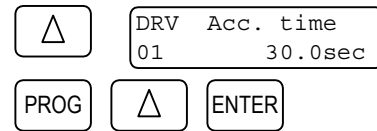

13. Press the UP-arrow key to display DRV 02. Change the Deceleration time by pressing the [PROG], arrow and [ENTER] keys.

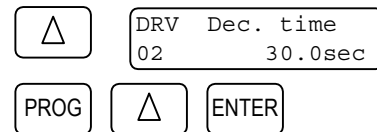

14. Press the [FWD] key to run motor in the forward direction,



15. Press the [REV] key to run motor in the reverse direction,



16. Press the [STOP] key to stop motor,



3.2 Operation Using Control Terminal – External Start, Stop and Speed Reference

1. Confirm 'Manual T/T' in DRV 00.

DRV	Manual T/T
00	FWD 60.00 Hz

2. If different, as in section 3.1 of this chapter, select 'Terminal' in FUN 01 and 'Terminal-1' or Terminal-2' in FUN 02.

FUN	Freq. set
01	Terminal

FUN	Run/stop set
02	Terminal-1

3. Install a potentiometer on terminals V1, VR and CM as shown right below. Select 'V1' in FUN 20 to control the speed by potentiometer alone.

FUN	V-I mode
20	V

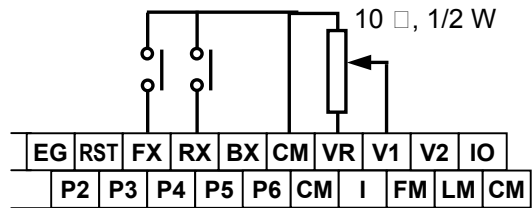

4. Set a frequency reference using the potentiometer. Make sure to observe the set value in DRV 00.

5. When a '4 - 20mA' current source is used as the frequency reference, use terminal I and CM. Select 'I' in FUN 20 to control the speed by the current source alone.

FUN	V-I mode
20	I

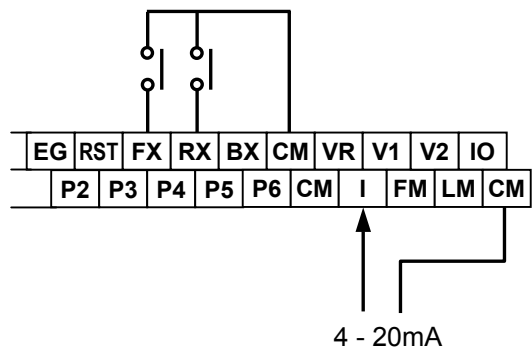

6. To run the motor in the forward direction, close the [FX] terminal to the [CM] terminal.

7. To run the motor in the reverse direction, close the [RX] terminal to the [CM] terminal.

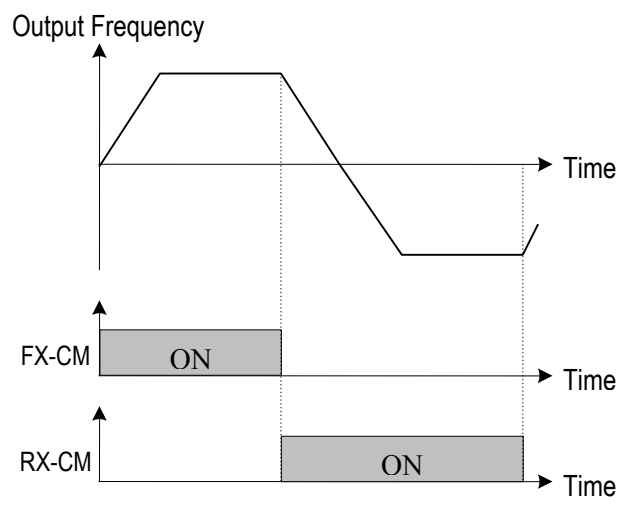

[FUN 02 - 'Terminal-1' Operation]

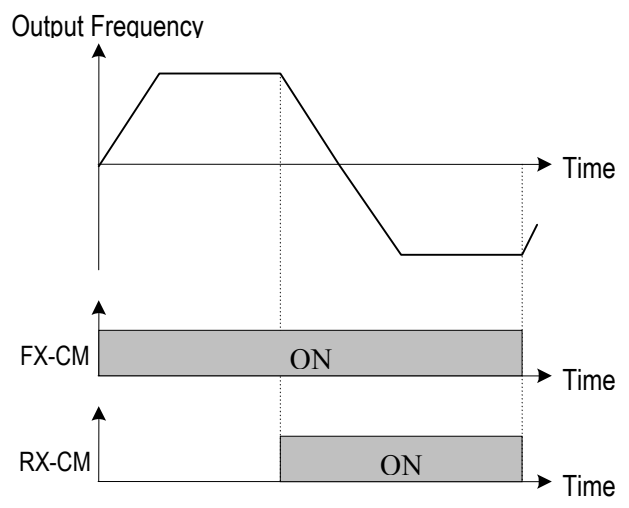

[FUN 02 - 'Terminal-2' Operation]

3.3 Operation Using Both Keypad and Control Terminals

3.3.1 Frequency Set by External Source and Run/Stop Set by Keypad

1. Confirm 'Manual K/T' in DRV 00.

DRV	Manual K/T
00	FWD 60.00 Hz

2. If different, as in section 3.1 of this chapter, select 'Terminal' in FUN 01 and 'Key' in FUN 02.

FUN	Freq. set
01	Terminal

FUN	Run/stop set
02	Key

3. Install a potentiometer to terminals V1, VR and CM. Select 'V1' in FUN 20 to control the speed by the potentiometer alone.

FUN	V-I mode
20	V1

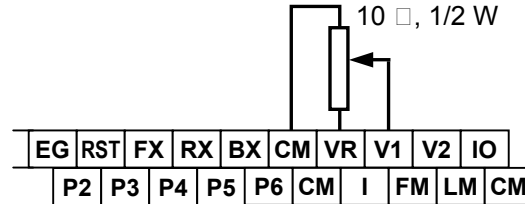

4. Set a frequency reference using the potentiometer. Make sure to observe the set value in DRV 00.

5. When a '4 - 20mA' current source is used as the frequency reference, use terminals I and CM. Select 'I' in FUN 20 to control the speed by the current source alone.

FUN	V-I mode
20	I

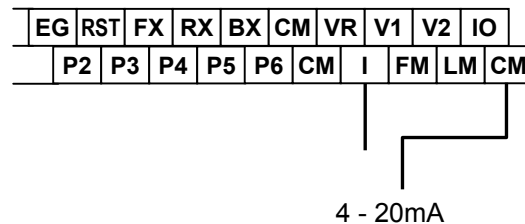

6. To run the motor in the forward direction, press the [FWD] key.

7. To run the motor in the reverse direction, press the [REV] key.

8. To stop the motor, press the [STOP] key.

3.3.2 Frequency Set by Keypad and Run/Stop by External Source

1. Confirm 'Manual T/K' in DRV 00.

DRV	Manual T/K
00	FWD 60.00 Hz

2. If different, as in section 3.1 of this chapter, select 'Key' in FUN 01 and 'Terminal-1' or Terminal-2' in FUN 02.

FUN	Freq. set
01	Key

FUN	Run/stop set
02	Terminal-1

3. Set a frequency reference in DRV 00.

DRV	Manual T/K
00	FWD 60.00 Hz

PROG	△	ENTER
------	---	-------

4. To run the motor in the forward direction, close the [FX] terminal to the [CM] terminal.

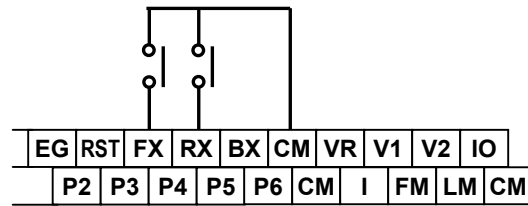

5. To run the motor in the forward direction, close the [RX] terminal to the [CM] terminal.

CHAPTER 4 - PARAMETER LIST

4.1 Drive Group

Code [DRV]	Description Drive Group	Keypad Display	Setting Range	Units	Factory Default	Adj. During Run	Page
00	Output Frequency (During Run) or Reference Frequency (During Stop)	Cmd. Freq	0 to FUN 04	0.01	0.00 [Hz]	Yes	39
01	Acceleration Time	Acc. time	0 to 6000 [sec]	0.1	30 [sec]	Yes	39
02	Deceleration Time	Dec. time	0 to 6000 [sec]	0.1	60 [sec]	Yes	39
03	Output Current	Current	The Load Current in RMS	-	- [A]	-	39
04	Output Speed	Speed	The Motor Speed in RPM	-	- [rpm]	-	39
05	Output Power Display	Power	Inverter Output Power	-	- [kW]	-	40
06	Fault Display	Fault	-	-	-	-	40

4.2 Function Group

Code [FUN]	Description Function Group	Keypad Display	Setting Range	Units	Factory Default	Adj. During Run	Page
00	Jump to Desired Code #	Jump Code	1 to 98	1	41	Yes	41
01	Frequency Setting Mode	Freq. set	Key, Terminal, Remote	-	Key	No	41
02	Run / Stop Mode Selection	Run/stop set	Key, Terminal-1, Terminal-2, Remote	-	Key	No	41
03	Run Prevention	Run prohibit	None, FWD disable, REV disable	-	None	No	42
04	Maximum Frequency Output Set Point	Freq. max	40 to 400 [Hz]	0.01	60 [Hz]	No	42
05	Base Frequency	Freq. base	40 to FUN 04	0.01	60 [Hz]	No	42
06	Starting Frequency	Freq. start	0.5 to 5[Hz]	0.01	0.5 [Hz]	No	42
07	Starting Frequency Hold Time	Hold time	0 to 10 [sec]	0.1	0.0 [sec]	Yes	43
08	Volts / Hz Pattern	V/F pattern	Linear, 2.0 (Squared), User, Auto	-	Linear	No	43
09	Torque Boost in Forward Direction	Fwd boost	0 to 20 [%]	1	2 [%]	No	44
10	Torque Boost in Reverse Direction	Rev boost	0 to 20 [%]	1	2 [%]	No	44
11	Acceleration Pattern	Acc. pattern	Linear, S-Curve, U-curve	-	Linear	No	45

Code [FUN]	Description Function Group	Keypad Display	Setting Range	Units	Factory Default	Adj. During Run	Page
12	Deceleration Pattern	Dec. pattern	Linear, S-Curve, U-Curve	-	Linear	No	45
13	Output Voltage Adjustment	Volt control	40 to 110 [%]	1	100 [%]	No	45
14	Energy Savings Level	Energy save	70 to 100 [%]	1	100 [%]	Yes	46
15	Stop Mode Selection	Stop mode	Decel, DCBR, Free Run	-	Decel	No	46
16	User V/F - Frequency 1	User-1f	0 to 30 [Hz]	0.01	10.00 [Hz]	No	46
17	User V/F - Voltage 1	User-1v	0 to 50 [%]	1	15 [%]	No	46
18	User V/F - Frequency 2	User-2f	FUN 16 to FUN 04	1	30.00 [Hz]	No	46
19	User V/F - Voltage 2	User-2v	FUN 17 to 100 [%]	1	50 [%]	No	46
20	Analog Speed Input Selection	V-I mode	V1, I, V1 + I, V2	-	V1	No	46
21	Analog Speed Input Filter Gain	Filter gain	1 to 100 [%]	1	25 [%]	Yes	48
22	Analog Speed Input Gain	Analog gain	50 to 250 [%]	0.1	100.0 [%]	Yes	48
23	Analog Speed Input Bias	Analog bias	0 to 200 [%]	0.1	100.0 [%]	Yes	48
24	Analog Speed Input Direction	Analog dir	Direct, Invert	-	Direct	Yes	48
25	Frequency Limit Selection	Freq. limit	No, Yes	-	No	No	50
26	Frequency High Limit Selection	F-limit high	0 to FUN 04	0.01	60.00 [Hz]	No	50
27	Frequency Low Limit Selection	F-limit low	0 to FUN 26	0.01	0.00 [Hz]	No	50
28	Jump Frequency Selection	Freq. jump	No, Yes	-	No	No	50
29	Jump Frequency 1	Freq-jump 1f	0 to FUN 04	0.01	10.00 [Hz]	No	50
30	Jump Frequency 2	Freq-jump 2f	0 to FUN 04	0.01	20.00 [Hz]	No	50
31	Jump Frequency 3	Freq-jump 3f	0 to FUN 04	0.01	30.00 [Hz]	No	50
32	Jump Frequency Bandwidth	Freq. band	0 to 30 [Hz]	0.01	5.00 [Hz]	No	50
33	DC Injection Braking Frequency	DC-br freq	0 to 60 [Hz]	0.01	0.50 [Hz]	No	51
34	DC Injection Braking On-Delay Time	DC-br block	0.5 to 5 [sec]	0.1	2 [sec]	No	51
35	DC Injection Braking Time	DC-br time	0.1 to 25 [sec]	0.1	0.5 [sec]	No	51
36	DC Injection Braking Voltage	DC-br value	1 to 20 [%]	1	1 [%]	No	51
37	Slip Compensation	Slip compen.	No, Yes	-	No	No	52
38	Rated Motor Slip	Rated slip	0 to 5 [Hz]	0.01	0.00 [Hz]	No	52
39	Rated Motor Current (RMS)	M-rated cur.	0.1 to 999 [A]	0.1	103.0 [A] ¹	No	52
40	No Load Motor Current in RMS	No-load cur.	0.1 to 300 [A]	0.1	0.1 [A]	No	52

¹ Default value will depend on the inverter capacity.

Code [FUN]	Description Function Group	Keypad Display	Setting Range	Units	Factory Default	Adj. During Run	Page
41	Inverter Capacity	Inv Capacity	RSI-040-H-2 RSI-050-H-2 RSI-250-H-4-L RSI-300-H-4-L	-	SV030iH-2 ²	No	53
42	Number of Auto Restart attempt	Retry number	0 to 10	1	0	Yes	53
43	Delay Time Before Auto Restart	Retry time	0 to 10 [sec]	1	1 [sec]	Yes	53
44	Fault Output Relay (A, C, B)	Relay mode	Retry 0, All Trips, LV + Retry 0, LV + All Trips	-	Retry 0	Yes	53
45	Stall Prevention Mode	Stall mode	None, Acc, Steady, Acc + Steady, Dec, Acc + Dec, Dec + Steady, Acc + Dec+ Steady	-	None	Yes	54
46	Stall Prevention Level	Stall level	CT: 30 to 150 [%] VT: 30 to 110 [%]	1 1	150 [%] 110 [%]	Yes Yes	54
47	Overload Warning Level	OL level	CT: 30 to 150 [%] VT: 30 to 110 [%]	1 1	150 [%] 110 [%]	Yes Yes	55
48	Overload Warning Hold Time	OL time	1 to 30 [sec]	1	10 [sec]	Yes	55
49	Over Current Trip Limit Level	OC lim level	CT: 30 to 200 [sec] VT: 30 to 150 [sec]	1 1	160 [%] 110 [%]	Yes Yes	56
50	Over Current Limit Time	OC lim. Time	0 to 60 [sec]	0.1	60 [sec]	Yes	56
51	Electronic Thermal Selection	ETH select	No, Yes	-	No	Yes	56
52	Electronic Thermal Level	ETH level	110 to 150 [%]	1	150 [%]	Yes	56
53	Electronic Thermal Characteristic (Motor Type) Selection	Motor type	General, Special	-	General	Yes	56
54	Number of Motor Poles	Pole number	2 to 12	1	4	Yes	57
55	IPF (Instant Power Failure) Restart Selection	IPF select	No, Yes	-	No	Yes	57
56	Speed Search Acceleration Time	SS acc. time	0.1 to 600 [sec]	0.1	5 [sec]	Yes	57
57	Speed Search Deceleration Time	SS dec. Time	0.1 to 600 [sec]	0.1	10 [sec]	Yes	57
58	Speed Search Gain	SS gain	0 to 200 [%]	1	100 [%]	Yes	57
59	Restart after Fault Reset Selection	RST-restart	No, Yes	-	No	Yes	58

² FUN 41 is set at its inverter capacity before shipping outside. However, inverter loses its capacity after parameter initialization in FUN 97. If the parameters are initialized, be sure to re-set the inverter capacity to the right capacity.

Code [FUN]	Description Function Group	Keypad Display	Setting Range	Units	Factory Default	Adj. During Run	Page
60	Restart after Power-On Selection	Power on st	No, Yes	-	No	Yes	59
61	Carrier Frequency	Carrier Freq	2 to 10 [kHz]	1	6 [kHz] ³	No	60
62	PI Control Selection	PI-control	No, Yes	-	No	No	60
63	PI Proportional Gain	P-gain	1 to 30000	1	10	Yes	60
64	PI Integral Gain	I-gain	1 to 30000	1	50	Yes	60
65	PI Feedback Selection	PI-fb select	I, V1, V2	-	I	No	60
66	PI Feedback Filter Gain	PI-fb filt. G	1 to 100 [%]	1	25 [%]	Yes	60
67	PI Feedback Gain	PI-fb gain	50 to 250 [%]	0.1	100.0 [%]	Yes	60
68	PI Feedback Bias	PI-fb bias	0 to 200 [%]	0.1	100.0 [%]	Yes	60
69	PI Feedback Direction	PI-fb dir	Direct, Invert	-	Direct	No	60
70	PI I Gain Scale	I term scale	1 to 100 [%]	1	100 [%]	Yes	60
71	PI Controller Error Direction	PI error dir	Direct, Invert	-	Direct	No	60
72	PI Control Bypass	Regul bypass	No, Yes	-	No	No	60
94 ⁴	CT/VT Selection	CT/VT	Constant Trq, Variable Trq	-	Constant Trq	No	61
95	Read Parameters into Keypad From Drive	Para. Read	No, Yes	-	No	No	62
96	Write Parameters to Drive From Keypad	Para. Write	No, Yes	-	No	No	62
97	Initialize Parameters to Factory Default Settings	Para. Init	No, Yes	-	No	No	62
98	Parameter Write Protection	Para. Lock	0 to 255	1	0	Yes	62

³ Carrier Frequency according to the Inverter Capacity (The Carrier Frequency is set to 3kHz for VT Rating)

Inverter	Setting Range	Factory Default	Inverter	Setting Range	Factory Default
RSi-040-H-2	2 to 10	6kHz	RSi-100-H-4-L	2 to 7	6kHz
RSi-050-H-2	2 to 10	6kHz	RSi-125-H-4-L	2 to 6	6kHz
RSi-060-H-2	2 to 8	6kHz	RSi-150-H-4-L	2 to 6	6kHz
RSi-075-H-2	2 to 8	6kHz	RSi-200-H-4-L	2 to 5	5kHz
RSi-040-H-4-L	2 to 10	6kHz	RSi-250-H-4-L	2 to 4	4kHz
RSi-050-H-4-L	2 to 10	6kHz	RSi-300-H-4-L	2 to 4	4kHz
RSi-060-H-4-L	2 to 8	6kHz	-	-	-
RSi-075-H-4-L	2 to 8	6kHz	-	-	-

⁴ VT is available only for 400V class inverter.

4.3 I/O Group

Code [I/O]	Description Function Group	Keypad Display	Setting Range	Units	Factory Default	Adj. During Run	Page
00	Jump to Desired Code #	Jump Code	1 to 65	1	1	Yes	65
01	Multi-function Input 1 (P1 terminal)	P1 Input	SPD_L, SPD_M, SPD_H, JOG, ACCT_L, ACCT_M, ACCT_H, UP, DOWN, HOLD, DIS_OPT, COMM_CONN, EXT_DCBR, EXT_TRIP	-	SPD_L	No	65
02	Multi-function Input 2 (P2 terminal)	P2 Input		-	SPD_M	No	65
03	Multi-function Input 3 (P3 terminal)	P3 Input		-	SPD_H	No	65
04	Multi-function Input 4 (P4 terminal)	P4 Input		-	ACCT_L	No	65
05	Multi-function Input 5 (P5 terminal)	P5 Input		-	ACCT_M	No	65
06	Multi-function Input 6 (P6 terminal)	P6 Input		-	ACCT_H	No	65
07	Multi-function Output 1 (OC1 terminal)	OC1 Output	FST_LO, FST_HI, FDT_HI, FDT_PULSE, FDT_BAND, OL, STALL, LV, RUN, COMM, STEP_L, STEP_M, STEP_H	-	STEP_L	No	68
08	Multi-function Output 2 (OC2 terminal)	OC2 Output		-	STEP_M	No	68
09	Multi-function Output 3 (OC3 terminal)	OC3 Output		-	STEP_H	No	68
10	Multi-function Output 4 (Aux.1 Relay term.)	AUX1 output		-	COMM	No	68
11	Multi-function Output 5 (Aux. 2 Relay term.)	AUX2 output		-	COMM	No	68
12	Jog Frequency	Jog freq.	0 to FUN 04	0.01	30.00 [Hz]	Yes	72
13	Step Speed 1	Step freq-1	0 to FUN 04	0.01	10.00 [Hz]	Yes	72
14	Step Speed 2	Step freq-2	0 to FUN 04	0.01	20.00 [Hz]	Yes	72
15	Step Speed 3	Step freq-3	0 to FUN 04	0.01	30.00 [Hz]	Yes	72
16	Step Speed 4	Step freq-4	0 to FUN 04	0.01	40.00 [Hz]	Yes	72
17	Step Speed 5	Step freq-5	0 to FUN 04	0.01	50.00 [Hz]	Yes	72
18	Step Speed 6	Step freq-6	0 to FUN 04	0.01	46.00 [Hz]	Yes	72
19	Step Speed 7	Step freq-7	0 to FUN 04	0.01	37.00 [Hz]	Yes	72
20	Acceleration Time 1	Acc time-1	0 to 6000 [sec]	0.1	1.0 [sec]	Yes	72
21	Deceleration Time 1	Dec time-1	0 to 6000 [sec]	0.1	1.0 [sec]	Yes	72
22	Acceleration Time 2	Acc time-2	0 to 6000 [sec]	0.1	2.0 [sec]	Yes	72
23	Deceleration Time 2	Dec time-2	0 to 6000 [sec]	0.1	2.0 [sec]	Yes	72
24	Acceleration Time 3	Acc time-3	0 to 6000 [sec]	0.1	3.0 [sec]	Yes	72

Code [I/O]	Description Function Group	Keypad Display	Setting Range	Units	Factory Default	Adj. During Run	Page
25	Deceleration Time 3	Dec time-3	0 to 6000 [sec]	0.1	3.0 [sec]	Yes	72
26	Acceleration Time 4	Acc time-4	0 to 6000 [sec]	0.1	4.0 [sec]	Yes	72
27	Deceleration Time 4	Dec time-4	0 to 6000 [sec]	0.1	4.0 [sec]	Yes	72
28	Acceleration Time 5	Acc time-5	0 to 6000 [sec]	0.1	5.0 [sec]	Yes	72
29	Deceleration Time 5	Dec time-5	0 to 6000 [sec]	0.1	5.0 [sec]	Yes	72
30	Acceleration Time 6	Acc time-6	0 to 6000 [sec]	0.1	6.0 [sec]	Yes	72
31	Deceleration Time 6	Dec time-6	0 to 6000 [sec]	0.1	6.0 [sec]	Yes	72
32	Acceleration Time 7	Acc time-7	0 to 6000 [sec]	0.1	7.0 [sec]	Yes	72
33	Deceleration Time 7	Dec time-7	0 to 6000 [sec]	0.1	7.0 [sec]	Yes	72
34	Output Voltage / Current Meter (LM Meter) Selection	LM meter	Voltage, Current	-	Voltage	Yes	72
35	Output Voltage / Current Meter (LM Meter) Adjustment (15V Pulse)	LM adj.	0 to 120 [%]	1	100 [%]	Yes	72
36	FM Meter Output Adjustment (15V Pulse)	FM adj.	0 to 120 [%]	1	100 [%]	Yes	73
37	IO Meter Output Adjustment (4 to 20mA)	IO adj.	0 to 120 [%]	1	100 [%]	Yes	73
38	Frequency Steady Level	FST-freq.	0 to FUN 04	0.01	0.50 [Hz]	No	73
39	Frequency Detection Level	FDT-freq.	0 to FUN 04	0.01	60.00 [Hz]	No	73
40	Frequency Detection Bandwidth	FDT-band	0 to 30 [Hz]	0.01	1.00 [Hz]	No	73
41	Multiplier Constant for Speed Display in 'DRV 04'	Mul. Factor	0 to 999	1	100	Yes	74
42	Divider Constant for Speed Display in 'DRV 04'	Div. factor	1 to 999	1	100	Yes	74
43	Status of Input Terminals	Ter. Input	-	-	-	-	74
44	Status of Output Terminals	Ter. Output	-	-	-	-	74
45	Software Version	S/W version	-	-	2.02	-	74
46	Fault History 1	Last fault 1	Fault Status, Freq. at Fault Current at Fault	-	-	Yes	74
47	Fault History 2	Last fault 2		-	-	Yes	74
48	Option 1 Selection	Option 1	None, RS485, ModBus RTU, Fnet, Device Net	-	None	No	75
49	Option 2 Selection	Option 2	None, MMC	-	None	No	75
50 ⁵	Inverter number for Option	Inv. Number	1 to 31	1	1	Yes	75
51	Baud rate for Option	Baud-rate	1200, 2400, 4800, 9600, 19200	-	9600 BPS	Yes	75

⁵ Option related parameters (FUN 50 ~ FUN 61) - Please refer to specific option manual.

Code [I/O]	Description Function Group	Keypad Display	Setting Range	Units	Factory Default	Adj. During Run	Page
52	Communication Timeout	Comm. Timeout	0 to 60 [sec]	0.1	10.0 [sec]	Yes	76
53	PG Slip Frequency for PG Option	PG Slip Freq	0 to 10 [Hz]	0.01	5.00 [Hz]	No	76
54	PG-P Gain for PG Option	PG. P-Gain	0 to 225	1	1	Yes	76
55	PG-I Gain for PG Option	PG. I-Gain	0 to 225	1	1	Yes	76
56	PG-Filter Gain for PG Option	PG. F-Gain	0 to 225	1	100	Yes	76
57	Encoder Selection for PG Option	Enc pulse	100, 500, 512, 1000, 1024, 2000, 2048, 4000	-	512 Pulse	Yes	76
58	Digital Input for DI/DA Option	DI Mode	None, Freq. 1, Freq. 2	-	Freq.1	Yes	76
59	Analog Output for DI/DA Option	DA Mode	Freq., Voltage, Current	-	Freq.	Yes	77
60	Analog Output Adjustment	DA adj.	80 to 120 [%]	1	100 [%]	Yes	77
61	Inverter Number for FNet	FN: St.ID	1 to 63	1	1	No	77
62	Device Net ID	DN: MAC ID	0 to 63	1	0	Yes	77
63	Device Net Communication Speed	DN: Baud Rate	125 kBPS 250 kBPS 500 kBPS	-	125 kBPS	Yes	77
64	Device Net Output Instance	DN: Out Inst	20 21 100 101	-	20	No	77
65	Device Net Input Instance	DN: In Inst	70 71 110 111	-	70	No	77

CHAPTER 5 - PARAMETER DESCRIPTION

5.1 Drive Group [DRV]

DRV 00: Output Frequency / Reference Frequency

```
DRV  Manual K/K
00 FWD  60.00 Hz
```

Setting Range: 0 to FUN 04 [Freq. max]

Factory Default: 0.00 Hz

When the inverter is stopped, the LCD display will read “Reference Frequency”. This is the Target Set Frequency. While the inverter is running, the LCD display will read “Output Frequency”.

The Output Frequency may be controlled by the digital **Keypad** or analog input (**Speed pot**) or (**4 ~ 20mA**). The factory default is [Keypad] mode. To change the output frequency from Keypad to Terminal, go to [FUN 01].

DRV 01: Acceleration Time DRV 02: Deceleration Time

```
DRV  Acc. Time
01      30.0 sec
```

```
DRV  Dec. Time
02      60.0 sec
```

Setting Range: 0 to 6000 sec

Factory Default: 5.0 sec

The inverter targets [FUN 04] when accelerating or decelerating. When [FUN 04] is set to ‘Maximum Frequency’, the acceleration time is the time taken by the motor to reach [FUN 04] from 0 Hz. The deceleration time is the time taken by the motor to reach 0 Hz from [FUN 04] (Maximum Frequency).

The acceleration and deceleration time can be changed to a preset transient time via multi-function inputs. By setting the multi-function inputs (P1~P6) to ‘ACCT_L’, ACCT_M’, ‘ACCT_H’ respectively, the Accel and Decel time set in [I/O 01] to [I/O 06] are supplied according to preset speeds assigned in [I/O 20] to [I/O 33].

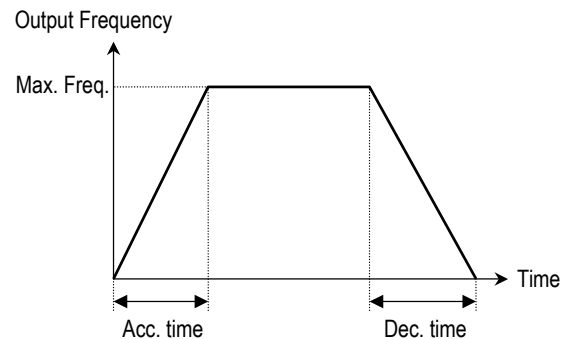

[Accel/Decel Operation]

DRV 03: Output Current

```
DRV  Current
03      10.0 A
```

Displays RMS value of the output current when the drive is running.

DRV 04: Output Speed

```
DRV  Speed
04      1800 rpm
```

Displays the speed of the motor in RPM. Line speed of the motor (m/min.) can be calculated by the number of motor poles [FUN 54] and the “Multiplier and Divider Factor” [I/O 41], [I/O 42].

DRV 05: Output Power Display

DRV	Power
05	47.8kW

Displays inverter output power (kW) when the drive is running.

DRV 06: Fault Display

DRV	Fault
05	No Fault

Displays the status of a fault. The output of the inverter is turned off when a fault condition occurs. The condition at the time of the fault can be examined (Motor Current and Output Frequency). The Stop LED blinks when a fault has occurred. The following table shows the fault item.

Display	Fault	Remark
OC Trip	Over Current	Latch
OV Trip	Over Voltage	Latch
EXT Trip	External Trip	Latch
BX	Inverter Disable	Unlatch
LV Trip	Low Voltage	Unlatch
Fuse Open	Fuse Blown	Latch
GF Trip	Ground Fault	Latch
Over Heat	Cooling Problem	Latch
ETH	Electronic Thermal Protected	Latch
OC Limit	Over Current	Latch
M/C Fail	Magnetic Contactor Problem	Unlatch
Inv OLT	Inverter Overload	Latch
SC Trip ¹	Short Through Trip	Latch

■ **Note:** A latched fault must be released by the [RESET] key or reset (RST) terminal. Unlatched faults are released upon condition or command.

¹ Available for models over 220kW. To reset this fault, the main input power should be disconnected.

5.2 Function Group

FUN 00: Jump to Desired Code

FUN	Jump Code
00	41

Setting Range: 0 to 98

Factory Default: 41

Any program code may be jumped to directly by entering the desired program code number.

Press the [PROG] key, scroll with the [▲ ▼] keys to the desired program code, the press the [ENTER] key to move to a desired program code.

FUN 01: Frequency Setting Mode

FUN	Freq. set
01	Key

Setting Range: Key, Terminal, Remote

Factory Default: Key

Key: The target frequency is controlled and established using the Keypad in [DRV 00].

Terminal: The target frequency is controlled and established using the Terminal with an analog speed pot (10V DC) or a (4 ~ 20mA) current signal.

Remote: The target frequency is controlled and established using Option Board.

■ **Note:** Analog input may be fine tuned when controlling the target frequency through the Terminal. (See FUN 20~22)

FUN 02: Run/Stop Mode Selection

FUN	Run/stop set
02	Key

Setting Range: Key, Terminal-1, Terminal-2, Remote

Factory Default: Key

This function selects Keypad, Terminal-1, Terminal-2 or Remote (Option Board) as the source for the Run/Stop command.

Key: Run/Stop is controlled by Keypad.

Terminal-1: Control terminals FX, RX and CM control Run/Stop.

FX-CM: Forward Run and Stop Control

RX-CM: Reverse Run and Stop Control

Terminal-2: Control terminals FX, RX and CM control Run/Stop.

FX-CM: Run/Stop control.

RX-CM: Forward and Reverse Control (Toggle)

Remote: Communication Option Board controls Run/stop.

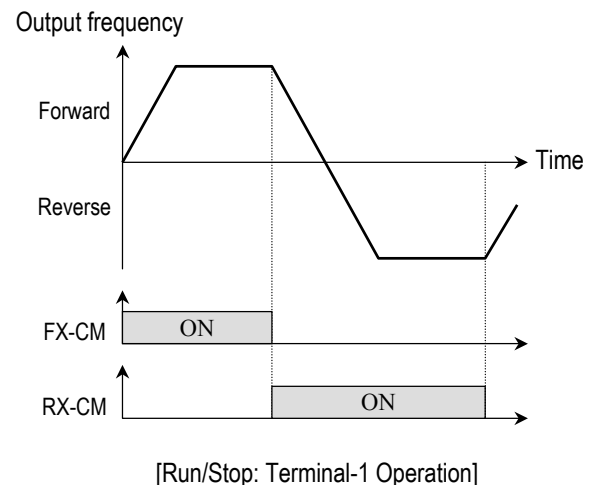

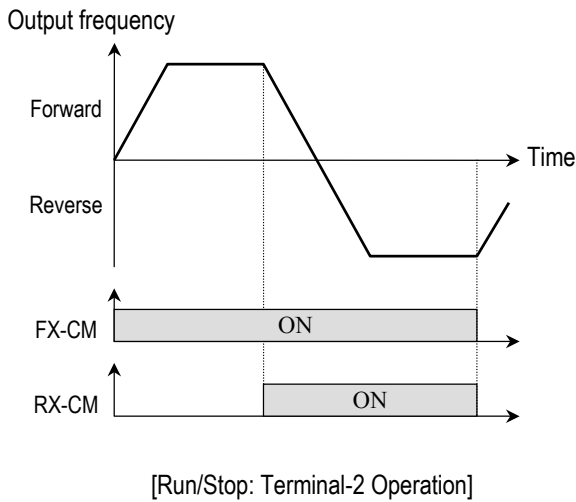

FUN 03: Run Prevention

FUN Run prohibit
03 None

Setting Range: None, FWD disable, REV disable
Factory Default: None

This function prevents reverse operation of the motor. This function may be used for loads that rotate only in one direction such as fans and pumps.

Setting Range	Description
None	Forward and Reverse run is available.
FWD disable	Forward run is prevented.
REV disable	Reverse run is prevented.

FUN 04: Maximum Frequency Set Point

FUN Freq. max
04 60.00 Hz

Setting Range: 40 ~ 400 Hz
Factory Default: 60.00 Hz

This function selects the maximum frequency output of the inverter. Caution should be exercised

when increasing the motor's command speed beyond its nameplate RPM. Please check with the motor manufacturer before exceeding the base speed of the motor.

FUN 05: Base Frequency Set Point

FUN Freq. base
05 60.00 Hz

Setting Range: 40 to FUN 04 [Freq. max]
Factory Default: 60.00 Hz

This function selects the output frequency of the inverter when operating at rated output voltage. Base frequency cannot be set above the maximum frequency. [FUN 04] establishes the frequency for maximum output voltage. This parameter is normally set to 60Hz. This allows constant torque operation of the motor up to its base speed. If base frequency is set to 60Hz and maximum frequency is set to 120Hz, the motor will run in the constant torque range up to the motor's base frequency, and in the constant horse power range from the motor's base frequency to twice the motor's base frequency.

FUN 06: Start Frequency Set Point

FUN Freq. start
06 0.50 Hz

Setting Range: 0.5 to 5Hz
Factory Default: 0.50 Hz

This function selects the start frequency when the inverter starts to output voltage.

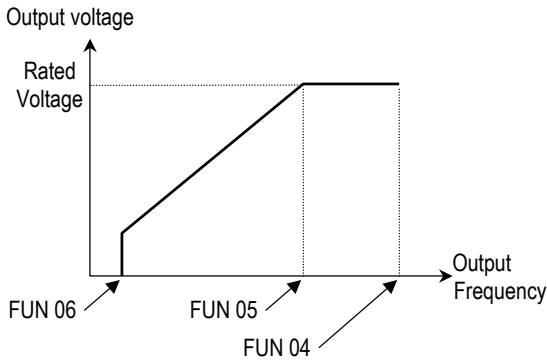

■ **Note:** If maximum frequency is decrease, all frequency parameters are adjusted to the maximum frequency set point.

FUN 07: Hold Time

```
FUN Hold time
07      0.0sec
```

Setting Range: 0 to 10 sec
Factory Default: 0.0 sec

This function selects the amount of time to hold the starting frequency before accelerating.

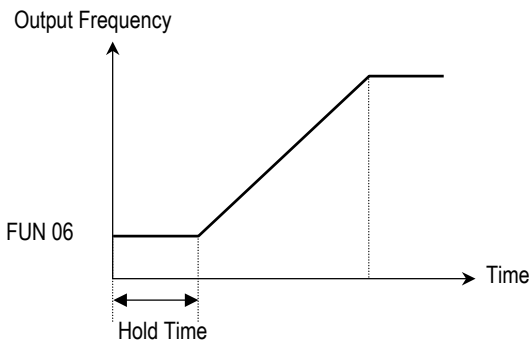

FUN 08: Volts/Hz Pattern

```
FUN V/F pattern
08      Linear
```

Setting Range: Linear, 2.0, User, Auto
Factory Default: Linear

This is the pattern of voltage/frequency ratio. Select the proper V/F pattern according to the load. The motor torque is dependent on this V/F pattern.

[Linear] pattern is used where constant torque is required. It maintains a linear volts/hertz ratio from zero to base frequency. This pattern is appropriate for conveyer, parking facility etc.

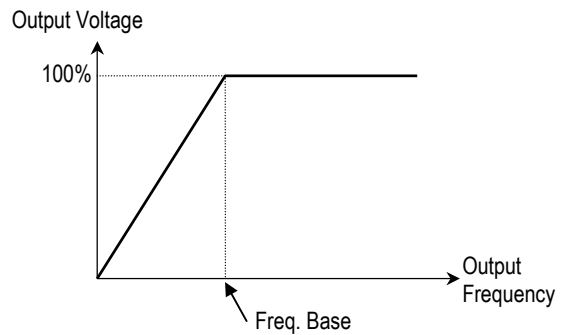

[2.0] pattern is used where variable torque is required. It maintains squared and cube powered ratio characteristics for the volts/hertz ratio. This pattern is appropriate for fans, pumps etc.

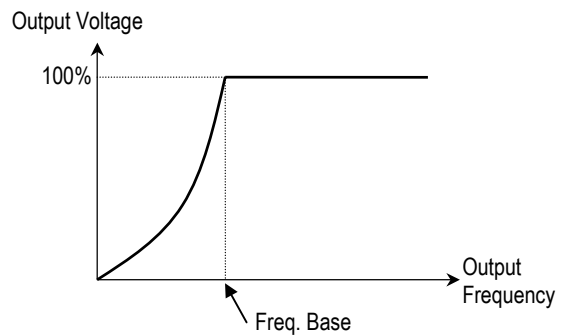

[User] pattern is used for special applications. Users can adjust the volts/hertz ratio according to the application. This is accomplished by setting the voltage and frequency, respectively, at two (2) points between starting frequency and base frequency. The two (2) points of voltage and

Chapter 5 - Parameter Description (Function Group)

frequency are set in [FUN 16] through [FUN 19].

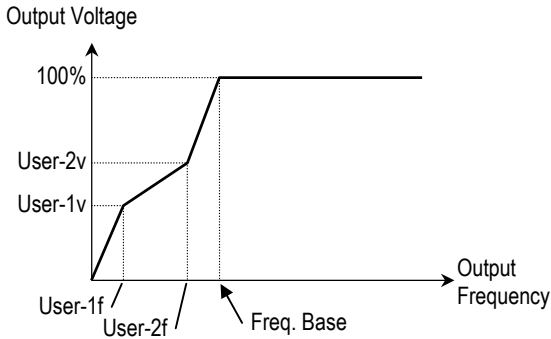

[Auto Boost] pattern is used where high starting torque is applications. This pattern will automatically boost the torque by sensing load current. It has a high torque characteristic at low speed. [Auto] pattern cannot be used when operating several motors with one inverter.

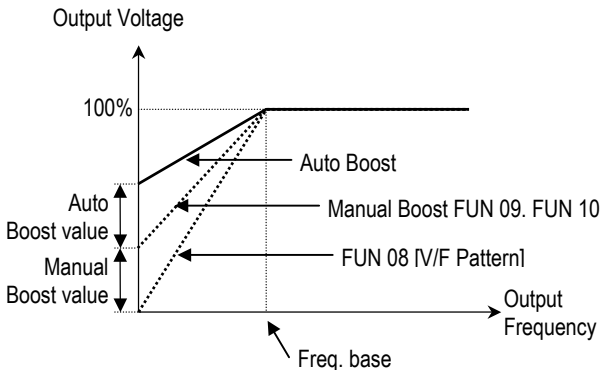

FUN 09: Manual Torque Boost – Forward FUN 10: Manual Torque Boost - Reverse

```
FUN  Fwd boost
09           2 %
```

Setting Range: 0 to 20 %
Factory Default: 2 %

```
FUN  Fwd boost
10           2 %
```

Setting Range: 0 to 20 %
Factory Default: 2 %

[FUN 09] and [FUN 10] establish the level of torque boost in the Forward and Reverse direction. These functions are used to increase the output voltage to the motor at low speeds for a higher V/F ratio loads that require higher than normal starting torque.

- **Note:** If the torque boost is set higher than needed, it is possible to over-flux or saturate the motor. This can result in the motor overheating.
- **Note:** The manual torque boost value can be added to "Linear" or "2.0" V/F pattern, but not to "User" or "Auto Boost" V/F pattern.

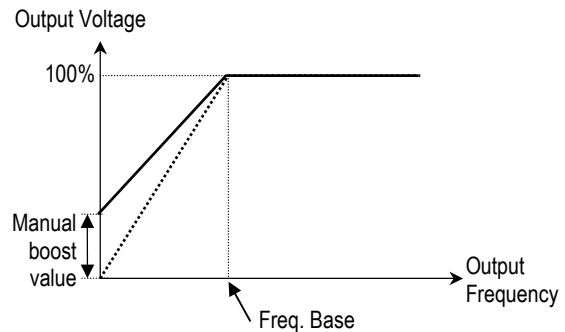

[Linear V/F Pattern: 'Torque Boost']

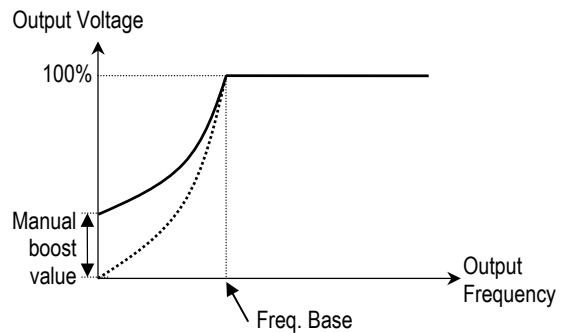

[2.0 V/F Pattern: 'Torque Boost']

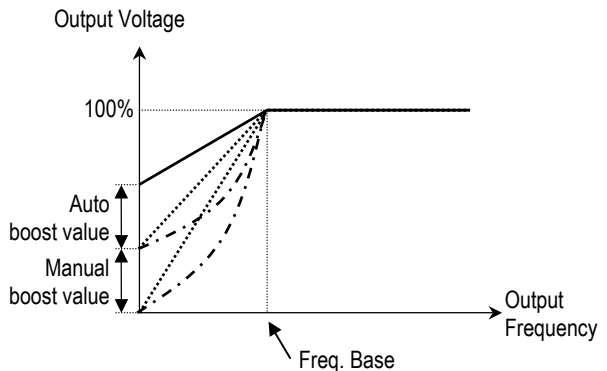

[Auto Boost Pattern: 'Torque Boost']

FUN 11: Acceleration pattern
FUN 12: Deceleration pattern

FUN Acc. pattern
 11 Linear

FUN Dec. pattern
 12 Linear

Setting Range: Linear, S-Curve, U-Curve
Factory Default: Linear

[FUN 11] and [FUN 12] selects different combinations of acceleration and deceleration patterns.

Linear: This is the general acceleration and deceleration pattern for constant torque applications.

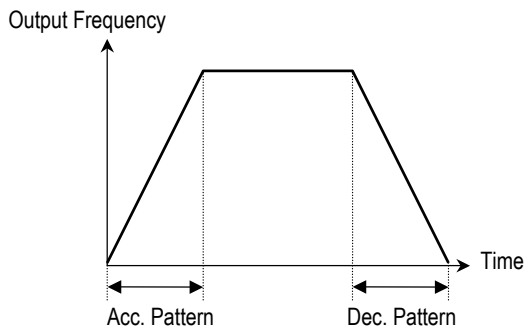

[Acc./Dec. Pattern: 'Linear']

S-Curve: This pattern allows the motor to accelerate and decelerate smoothly. At this time, the actual acceleration and deceleration time are longer about 10% than the acceleration and deceleration time set in DRV 01-02.

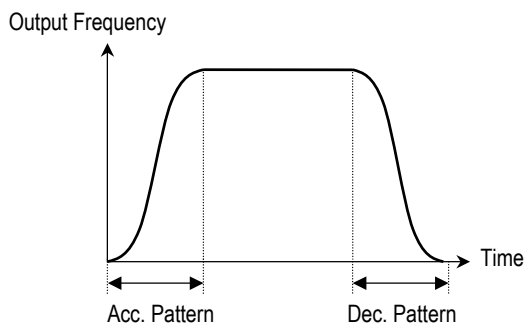

[Acc./Dec. Pattern: 'S-Curve']

U-Curve: This pattern provides more efficient control of acceleration and deceleration in the application like winding machines.

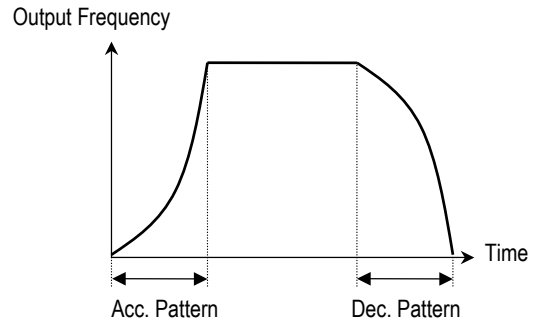

[Acc./Dec. Pattern: 'U-Curve']

FUN 13: Output Voltage Adjustment

FUN Volt control
 13 100 %

Setting Range: 40 to 110%
Factory Default: 100%

This function is used to adjust the output voltage of the inverter. This is useful when using a motor with a lower rated voltage than the main input voltage. When this is set at 100%, the inverter outputs its rated voltage.

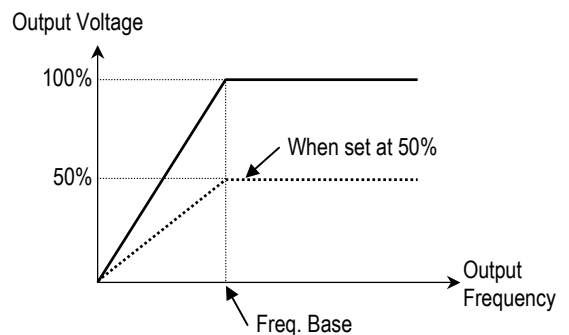

[Output Voltage Adjustment]

FUN 14: Energy Savings Level

FUN	Energy save
14	100 %

Setting Range: 70 to 100%
Factory Default: 100%

This function is used to reduce the output voltage in applications that do not require high torque and current at steady speed. The inverter reduces its output voltage after accelerating to the reference frequency (steady speed) if the energy save level is set less than 100%.

Caution: This function may cause over-current trips due to the lack of output torque in a fluctuating load situation. Further, if the Energy Save parameter is reduced too much, the applied motor voltage may be too low for correct motor operation and motor stalling and/or overheating may result.

Note: This function does nothing with a 100% set point value.

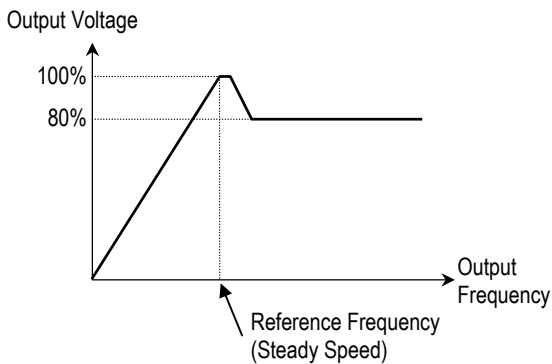

FUN 15: Stop Mode Selection

FUN	Stop mode
15	Decel

Setting Range: Decel, DCBR, Free Run
Factory Default: Decel

This function is used to select stopping mode of the motor.

Decel: [Deceleration]

Inverter stops by the deceleration pattern selected in FUN 12 [Dec. pattern].

DCBR: [DC Injection Braking]

Inverter stops with DC injection braking. Inverter outputs DC voltage when the frequency reaches the DC injection braking frequency set in FUN 33 during deceleration.

Free Run: [Coast to Stop]

Inverter cuts off its output immediately when the stop signal is commanded.

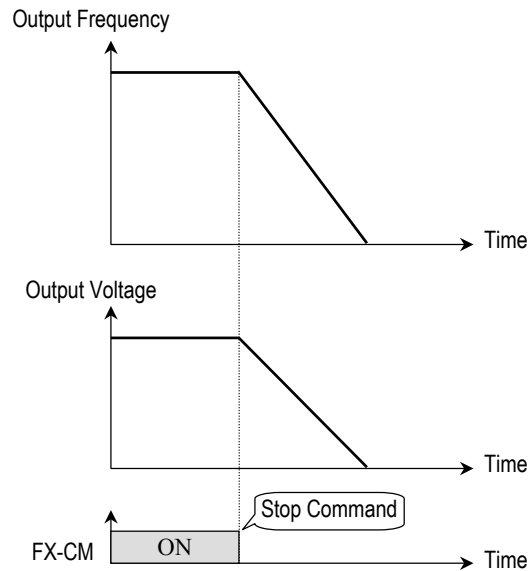

[Stop Mode: 'Decel']

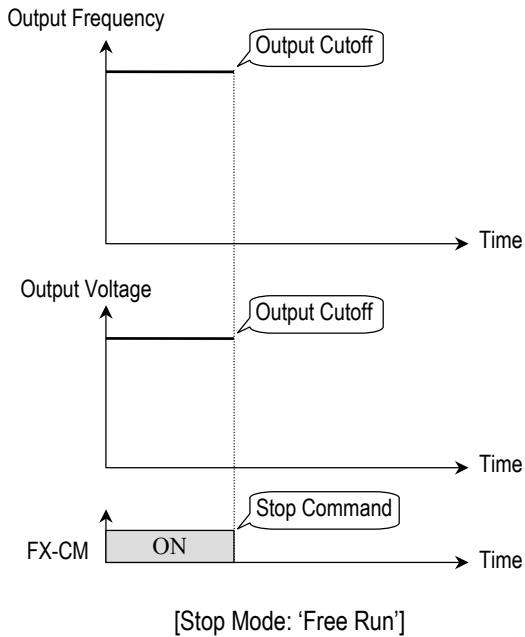
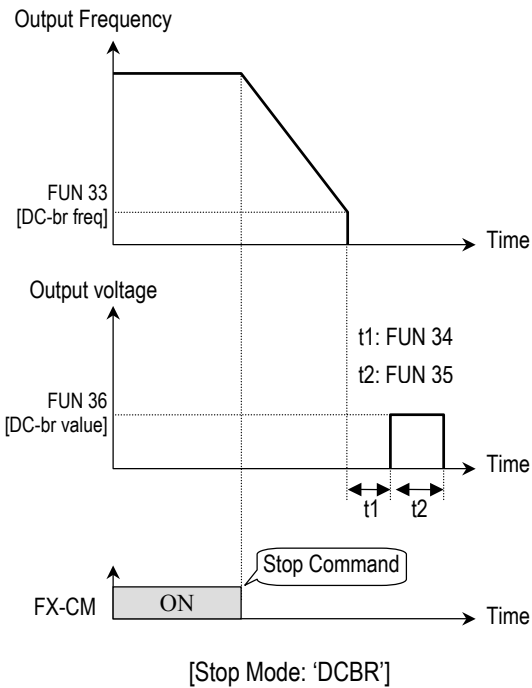

FUN 16 ~ FUN 19: User V/F Pattern

FUN User-1f
16 10.00 Hz

Setting Range: 0 to 30Hz
Factory Default: 10Hz

FUN User-1v
17 15%

Setting Range: 0 to 50%
Factory Default: 15%

FUN User-2f
18 30.00 Hz

Setting Range: FUN 16 to FUN 04
Factory Default: 30Hz

FUN User-2v
19 50%

Setting Range: FUN 17 to 100%
Factory Default: 50%

These functions are available only when 'User V/F' is selected in FUN 08 [V/F pattern]. Users can make the custom V/F pattern by setting two (2) points between [FUN 06] (Starting Frequency) and [FUN 05] (Base Frequency)

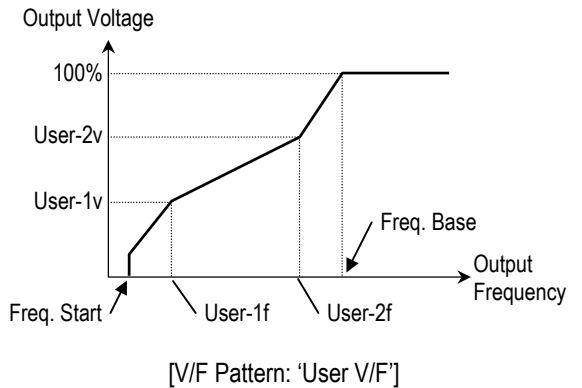

FUN 20: Analog Speed Ref. Selection

FUN V-I mode
20 V1

Setting Range: V1, I, V1+I, V2
Factory Default: V1

Chapter 5 - Parameter Description (Function Group)

This function is used to set the analog speed command. Use this function when operating from the terminal strip. When using 0~10VDC, 4~20mA input signal or PI control, be sure that [FUN 01] is set for terminal control.

V1: [Voltage 1]

A 0 to 10V DC signal is used for analog speed reference. When using a speed pot, connect it to VR, V1 and CM terminals.

I: [Current]

A 4 to 20mA signal is used for analog speed reference. Connect the current source to I and CM terminals.

V1+I: [Voltage 1+Current]

A 0 to 10V DC and a 4 to 20mA signals are used for analog speed reference at the same time. One signal overrides the other signal.

V2: [Voltage 2]

V2 has the same function as V1.

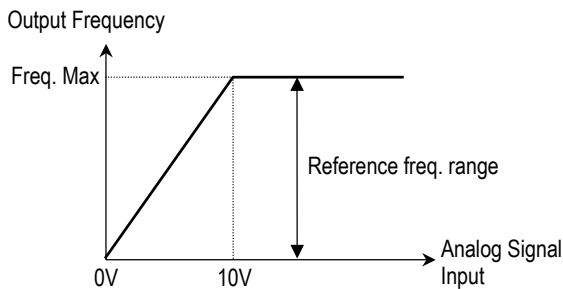

[V-I Mode: 'V1' (Voltage 1)]

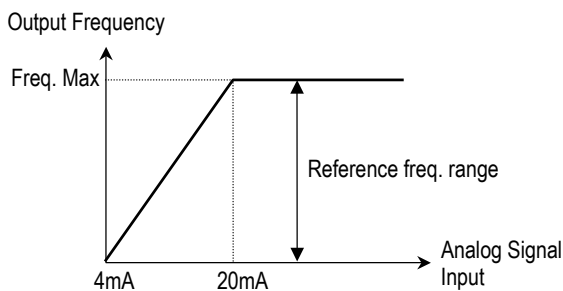

[V-I Mode: 'I' (Current)]

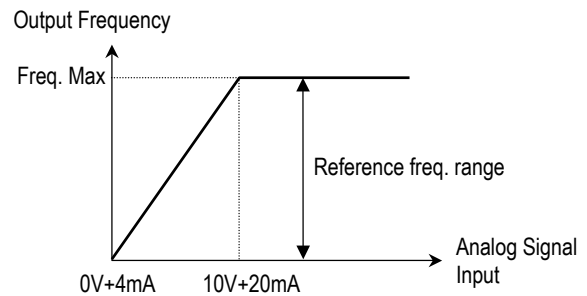

[V-I Mode: 'V1+I' (Voltage 1+Current)]

- **Note:** If the PI control [FUN 62] is selected, the value in [FUN 01] will be ignored. The main speed command is automatically selected as 0~10V with the feedback command being 4~20mA.

FUN 21: Analog Speed Input Filter Gain

FUN 22: Analog Speed Input Gain

FUN 23: Analog Speed Input Bias

FUN 24: Analog Speed Input Direction

FUN	Filter gain
21	50 %

Setting Range: 1 to 100%

Factory Default: 50%

This function establishes the response value of the analog speed reference. For a faster response, set the gain lower and vice versa

FUN	Analog gain
22	100.0 %

Setting Range: 50.0 to 250.0%

Factory Default: 100.0%

This function is used to determine the analog input scale from a speed potentiometer, 0~10V signal or 4~20mA signal. When this value is set at 50.0%, the inverter outputs maximum frequency at 5V DC or 12mA.

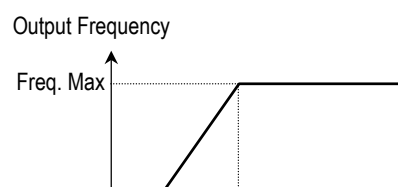

[Analog Gain: '100.0%']

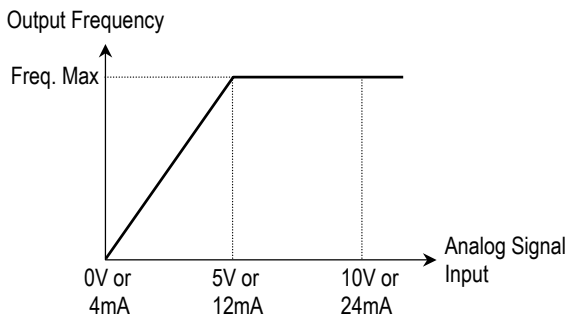

[Analog Gain: '50.0%']

```
FUN Analog bais
23      100.0 %
```

Setting Range: 0.0 to 200.0%
Factory Default: 0.0%

This function is used to give a minimum output signal with a zero analog signal from a manual potentiometer, 0~10V signal or 4~20mA signal.

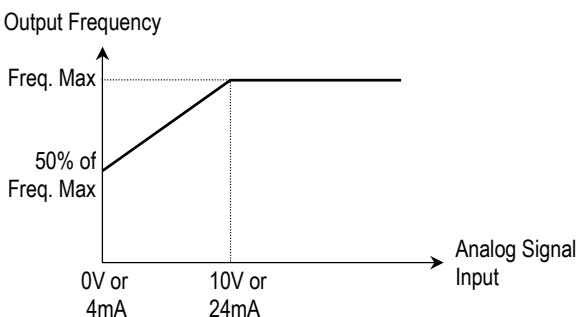

[Analog Bias: '50.0%']

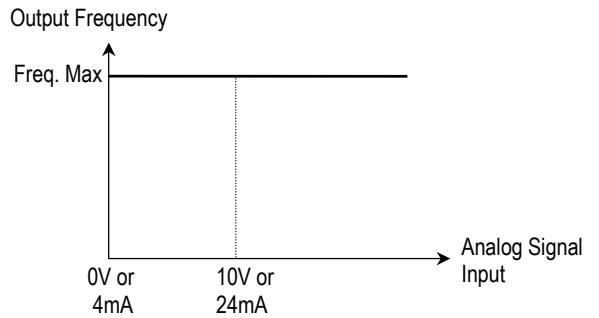

[Analog Bias: '100.0%']

```
FUN Analog dir
24      Direct
```

Setting Range: Direct, Invert
Factory Default: Direct

This function creates either a linear relationship between the analog input reference and the analog speed command, or creates an inverted linear relationship between the analog input reference and the analog speed command 0~10V signal or 4~20mA signal.

Direct: The output frequency is directly proportional to the analog signal input.

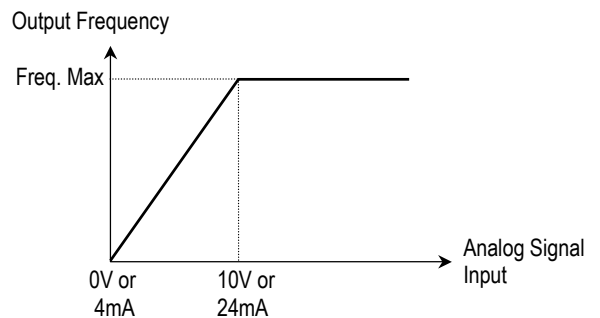

[Analog dir: 'Direct']

Invert: The output frequency is inversely proportional to the analog signal input.

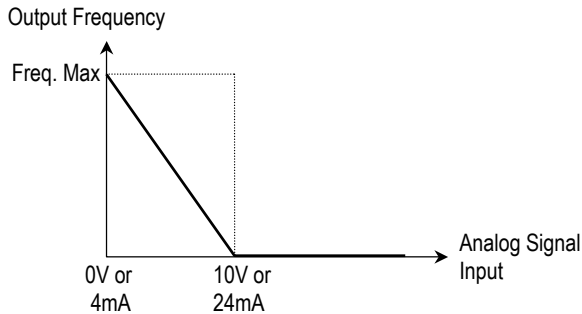

[Analog dir: 'Invert']

FUN 25: Frequency Limit Selection
FUN 26: High Limit Frequency
FUN 27: Low Limit Frequency

```
FUN  Freq. limit
25   --- No ---
```

Setting Range: No, Yes
Factory Default: No

```
FUN  F-limit high
26      60.00 Hz
```

Setting Range: 0 to FUN 04 [Freq. max]
Factory Default: 0%

```
FUN  F-limit low
27      0.00 Hz
```

Setting Range: 0 to FUN 26 [F-limit high]
Factory Default: 0%

[FUN 25] selects the limits for the inverter operating frequency. If [FUN 24] is set to 'Yes', the inverter operates within the upper and lower limit setting. The inverter operates at the upper or the lower limit when the frequency reference is outside the frequency limit range.

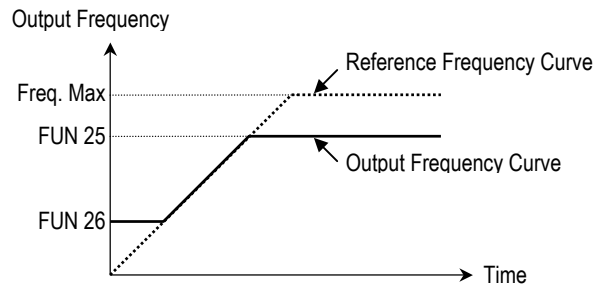

[Freq. limit: 'Yes']

- **Note:** When setting the frequency below the low limit or above the high limit, the drive will automatically ramp inside the limited setting.
- **Note:** When accelerating or decelerating, the output frequency follows the normal acceleration and deceleration rates.

FUN 28: Frequency Jump Selection
FUN 29: Frequency Jump 1
FUN 30: Frequency Jump 2
FUN 31: Frequency Jump 3
FUN 32: Frequency Jump Bandwidth

```
FUN  Freq. jump
28   --- No ---
```

Setting Range: No, Yes
Factory Default: No

```
FUN  Freq-jump 1f
29      10.00 Hz
```

Setting Range: 0 to FUN 04 [Freq. max]
Factory Default: 10Hz

```
FUN  Freq-jump 2f
30      20.00 Hz
```

Setting Range: 0 to FUN 04 [Freq. max]
Factory Default: 20Hz

FUN Freq-jump 3f
31 30.00 Hz

Setting Range: 0 to FUN 04 [Freq. max]
Factory Default: 30Hz

FUN Freq. band
32 5.00 Hz

Setting Range: 0 to 30Hz
Factory Default: 5Hz

To prevent undesirable resonance and vibration on the structure of the machine, this function locks out the resonance frequency from occurring. Each jump frequency also has a bandwidth. This is a span of the particular jump frequency selected. Three different jump frequencies can be set. However, there is only one bandwidth frequency available. This jumping of frequencies does not occur during accelerating or decelerating. It only occurs during continuous operation. To use just one jump frequency, both Frequency jump 1 and Frequency jump 2 should be set 0 Hz. To use two jump frequencies, Frequency jump 3 should be set 0 Hz.

- **Note:** When the reference frequency is set inside the jump frequency, the output frequency goes to the frequency marked by "●" symbol.

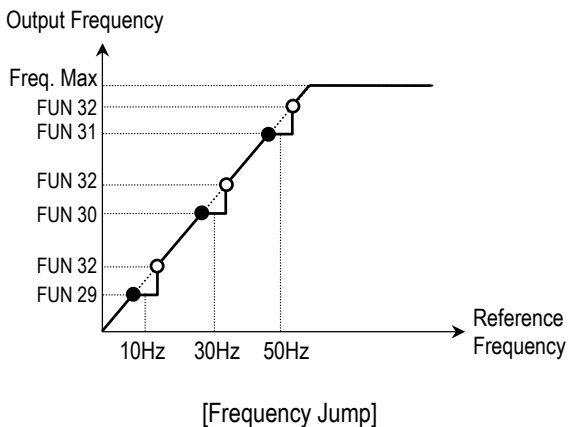

FUN 33: DC Injection Braking Frequency
FUN 34: DC Injection Braking On-Delay Time
FUN 35: DC Injection Braking Time
FUN 36: DC Injection Braking Voltage

FUN DC-br freq
33 0.5 Hz

Setting Range: 0 to 60Hz
Factory Default: 0.5Hz

FUN DC-br block
34 2.0 sec

Setting Range: 0.5 to 5 sec
Factory Default: 2.0sec

FUN DC-br time
35 0.5 sec

Setting Range: 0.1 to 25 sec
Factory Default: 0.5sec

FUN DC-br value
36 1 %

Setting Range: 1 to 20 %
Factory Default: 1%

The DC injection braking function is enabled in FUN 15 [Stop mode]. By introducing a DC voltage to the motor windings, this function stops the motor immediately.

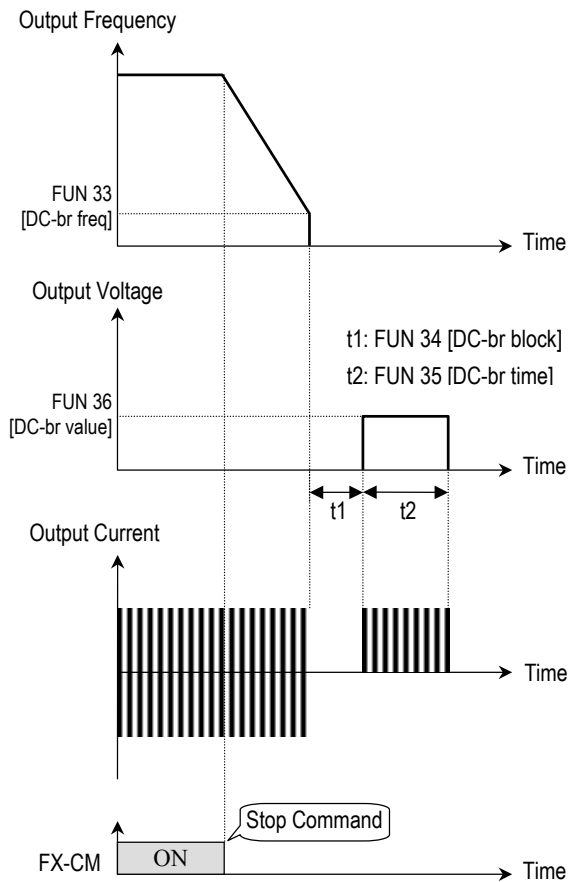

[DC Injection Braking with 'Stop mode: DCBR']

■ **Note:** The on-delay time must be set according to the DC injection braking frequency and the magnitude of the load. If the on-delay time is set 0 sec, the drive may trip on over current. This is because the DC voltage is applied before the motor's residual magnetic field and voltage have decayed.

[FUN 33] (DC Injection Braking Frequency) is the frequency at which the inverter starts to output DC voltage during deceleration.

[FUN 34] (DC Injection Braking On-Delay Time) is the inverter output blocking time before DC injection braking.

[FUN 35] (DC Injection Braking Time) is the time the DC current is applied to the motor.

[FUN 36] (DC Injection Braking Voltage) is the

DC voltage applied to the motor and is based upon rated inverter output voltage.

FUN 37: Slip Compensation
FUN 38: Rated Slip of Motor
FUN 39: Rated Current of Motor
FUN 40: No Load Current of Motor

FUN Slip compen.
 37 --- No ---

Setting Range: No, Yes
Factory Default: No

FUN Rated slip
 38 0.00 Hz

Setting Range: 0 to 5Hz
Factory Default: 0Hz

FUN M-rated cur.
 39 122.0 A

Setting Range: 0.1 to 999A
Factory Default: depend on [FUN 41]

FUN No-load cur.
 40 0.1 A

Setting Range: 0.1 to 300A
Factory Default: 4.0A

This function is used to maintain the motor speed constant. To keep the motor speed constant, the output frequency varies within the limit of the slip frequency-FUN 38 [Rated slip] according to the load current. For example, when the motor speed decreases below the reference speed (frequency) due to a heavy load, the inverter increases the output frequency higher than the reference frequency to increase the motor speed. The inverter increases or decreases the output by delta frequency shown below.

$$\text{Delta Freq.} = \frac{\text{Output Current} - \text{No-load Current}}{\text{Rated Current} - \text{No-load Current}} \times \text{Rated Slip}$$

Output frequency = Reference freq. + Delta freq.

FUN 41: Inverter Capacity

FUN Inv Capacity
41 RSI050H-4

Setting Range: RSI-040-H-2 – RSI-300-H-4-L
Factory Default: depend on model number

Description:

[FUN 41] selects the inverter capacity. Inverter capacity must be set correctly for proper current calculations and protective functions to occur.

FUN 42: Auto Restart
FUN 43: Restart On-Delay Time

FUN Retry number
42 0

Setting Range: 0 to 10
Factory Default: 0

FUN Retry time
43 1.0sec

Setting Range: 0 to 10 sec
Factory Default: 1sec

[FUN 41] establishes the number of times the inverter will try to restart itself after an over current, over voltage, ground fault, or over current limit occurs. This function uses the Speed Search function. See [FUN 56] through [FUN 58].
[FUN 42] establishes the amount of wait time

between Auto-Restart attempts. When an under voltage fault or inverter disable (BX) occurs, the drive does not restart automatically.

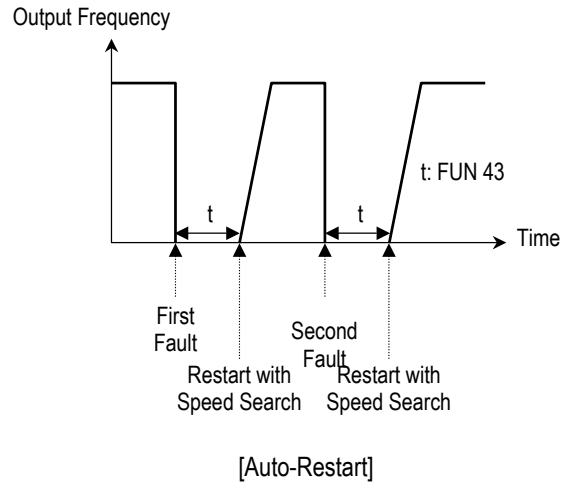

- Note: Inverter decreases the retry number by ones as a fault occurs. When restarted without a fault during 30 seconds, the inverter increases the retry number by ones.

FUN 44: Fault Output Relay (A, B, C)

FUN Relay mode
44 Retry 0

Setting Range: Retry 0, All Trips, LV+Retry 0, LV+All Trips
Factory Default: Retry 0

[FUN 44] determines the operation of the fault relay after a fault has occurred. The output relay terminals are A, B, C on control terminal strip.

Retry 0: The output relay operates when the retry number decreases to 0 by faults. When the retry number is set to 0 by default, the relay operates at any faults **except** at under voltage and BX (inverter disable) fault.

All Trips: The output relay operates on all faults **except** under voltage and BX (inverter disable)

fault. The output relay operates regardless of the retry number.

LV+Retry 0: In case of an under voltage fault or a 0 restart count, the output relay operates. For a BX (inverter disable) input, the relay does NOT operate.

LV+All Trips: When a fault including under voltage occurs, the output relay operates. In BX (inverter disable), the relay does NOT operate. The output relay operates regardless of the retry number.

FUN 45: Stall Prevention
FUN 46: Stall Prevention Level

FUN	Stall mode
45	None

Setting Range: None, Acc, Steady, Acc+Steady, Dec, Acc+Dec, Dec+Steady, Acc+Dec+Std
Factory Default: None

FUN	Stall level
46	150 %

Setting Range: CT : 30 to 150% VT : 30 to 110%
Factory Default: 150% 110%

[FUN 45] is used to prevent the motor from stalling by reducing the inverter output frequency until the motor current decreases below the stall prevention level.

[FUN 46] assigns the stall prevention level in percent of motor FLA.

Acc: During acceleration, when the output current of the inverter reaches the stall prevention level, the drive reduces its output frequency. When the current reduces below the stall prevention level, the drive will begin to accelerate again.

Steady: During steady state, when the output

current of the inverter reaches the stall prevention level, the drive reduces its output frequency. When the current is reduced below the stall prevention level, the drive returns to its command frequency.

Dec: During deceleration, when the output current of the inverter reaches the stall prevention level, the drive reduces its output frequency. When the current reduces below the stall prevention level, the drive will begin to decelerate again.

Acc+Steady: Stall prevention is active during acceleration and steady state operation.

Acc+Dec: Stall prevention is active during acceleration and deceleration.

Dec+Steady: Stall prevention is active during deceleration and steady state operation.

Acc+Dec+Std: Stall prevention is active during acceleration, deceleration and steady state operation.

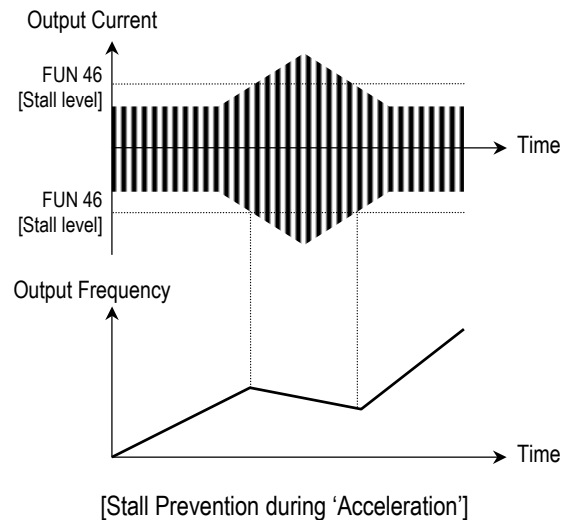

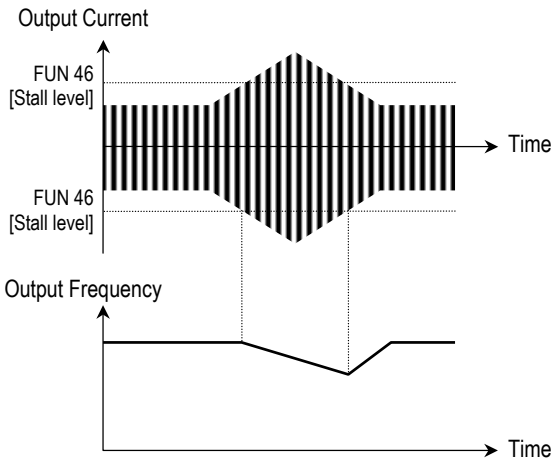

[Stall Prevention during 'Steady']

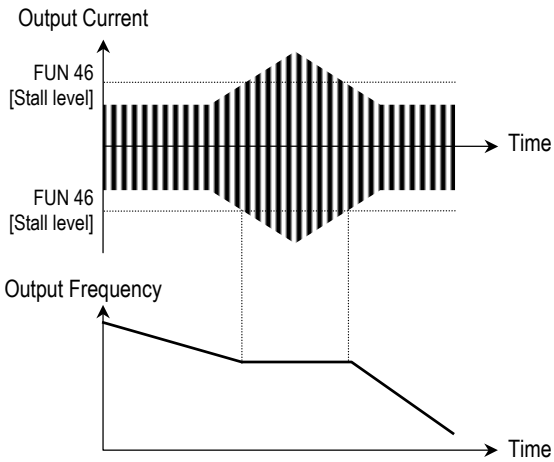

[Stall Prevention during 'Deceleration']

FUN 47: Overload Warning Level
FUN 48: Overload Warning On-Delay Time

FUN	OL level
47	150 %

Setting Range: CT : 30 to 150% VT : 30 to 110%
Factory Default: 150% 110%

FUN	OL time
48	10.0sec

Setting Range: 1 to 30 sec
Factory Default: 10sec

[FUN 47] is used to provide motor overload detection. When the output current of the inverter has reached the “Overload Warning Level” and after the [FUN 48] on-delay time has been reached, a multi-output signal may be turned on.

For example, define multi-output OC1 in [I/O 07 ~ 09] (OC1 Output) to OL. The multi-output is open collector (24V DC, 50mA).

Open Collector Outputs
 (24VDC, 50mA)

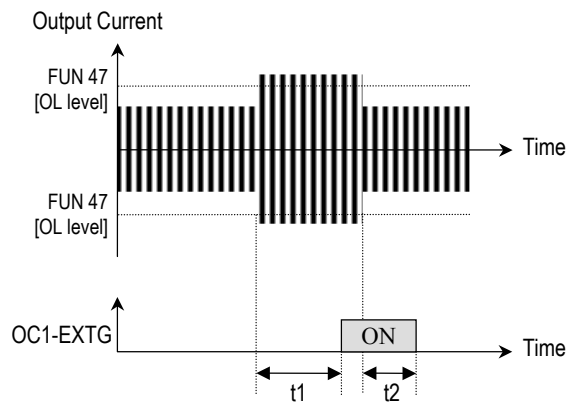
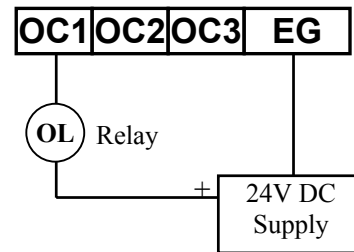

t1: Overload warning time - FUN 48 [OL time]
 t2: Overload warning time / 2

[Overload Warning]

FUN 49: Over Current-Limit Trip Level
FUN 50: Over Current-Limit Trip Time

```
FUN OC lim level
49      160 %
```

Setting Range: CT: 30 to 200% VT: 30 to 150%
Factory Default: 160% 110%

```
FUN OC lim. time
50      60.0sec
```

Setting Range: 0 to 60sec
Factory Default: 60sec

[FUN 49] and [FUN 50] turn off the output current or the inverter when the motor reaches Over Current-Limit Trip Level and has timed out. These functions protect against abnormal load conditions.

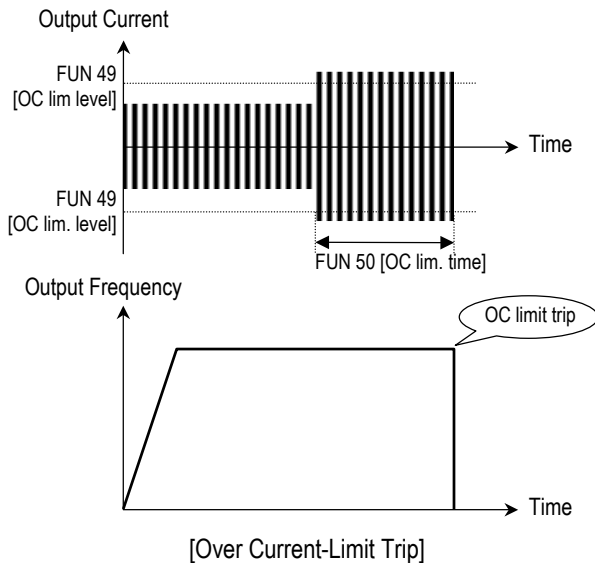

FUN 51: Electronic Thermal (ETH) Selection
FUN 52: Electronic Thermal Level
FUN 53: Motor Type

```
FUN ETH select
51 --- No ---
```

Setting Range: No, Yes
Factory Default: No

```
FUN ETH level
52      150 %
```

Setting Range: 30 to 150%
Factory Default: 150%

```
FUN Motor type
53      General
```

Setting Range: General, Special
Factory Default: General

These functions are used to protect the motor from overheating without that addition of a separate thermal overload relay. The inverter calculates the temperature rise (i^2t) of the motor using several parameters and determines whether or not the motor is overheated. When an Electronic Thermal Overload trip occurs the inverter will turn off and display an ETH trip message.

The following parameters must be set for the ETH function to operate correctly:

[FUN 39] The Rated Motor Current must be set.

[FUN 51] Activates the Electronic Thermal Overload function by setting 'Yes'.

[FUN 52] Establishes the reference level of current that will cause a thermal overload trip to occur in 60 seconds.

Example: If the Electronic Thermal Level

[FUN52] is set to 150% a thermal overload trip will occur in 60 seconds if the motor is run at 150% percent of rated current [FUN 39].

$$Time_to_Trip \approx 60 \text{ sec} * \frac{\left(\frac{[FUN52]}{100\%}\right)^2 - 1}{\left(\frac{MotorCurrent}{[FUN39]}\right)^2 - 1}$$

[FUN 53] adjusts the ETH calculation based on the method of motor cooling. The motor cooling method must be selected correctly. The selections are either 'General' or 'Special'.

A '**General**' or 'Self Cooled' motor is a motor that has a cooling fan connected directly to the shaft of the motor. The cooling of a self-cooled motor decreases when the motor is running at low speeds. The motor overload is adjusted as the motor speed decreases to compensate for this effect.

A '**Special**' motor is a motor that uses a separately powered cooling fan. As the motor speed changes, the cooling do not change.

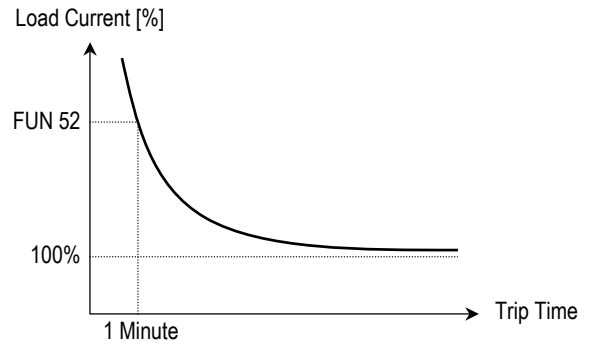
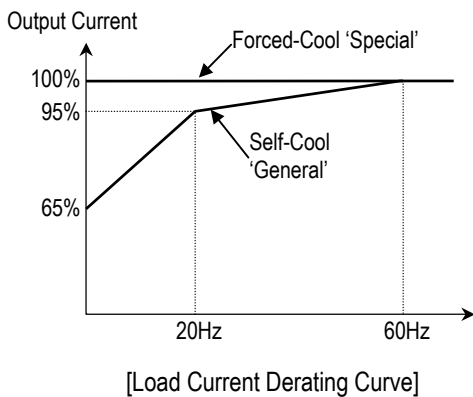

[Motor i²t Characteristic Curve]

FUN 54: Number of motor poles

FUN Pole number
54 4

Setting Range: 2 to 12
Factory Default: 4

This parameter selects the number of poles on the motor. Used to display correct speed based on output frequency.

FUN 55: IPF Restart Selection
FUN 56: Speed Search Acceleration Time
FUN 57: Speed Search Deceleration Time
FUN 58: Speed Search Gain

FUN IPF select
55 --- No ---

Setting Range: No, Yes
Factory Default: No

FUN ss acc. time
56 5.0sec

Setting Range: 0.1 to 600sec
Factory Default: 5sec

```
FUN ss dec. time
57      10.0sec
```

Setting Range: 0.1 to 600sec
Factory Default: 10sec

```
FUN ss gain
58      100 %
```

Setting Range: 0 to 200%
Factory Default: 100%

These functions are used to permit automatic restarting after Instantaneous Power Failure without waiting for the motor to stop.

- [FUN 55] selects the 'IPF Restart' function
- [FUN 56] determines the acceleration time during speed search.
- [FUN 57] determines the acceleration time during speed search.
- [FUN 58] determines the gain during speed search.

- The speed search gain and Acc/Dec time should be set after considering the moment of inertia (GD^2) and size of the load.

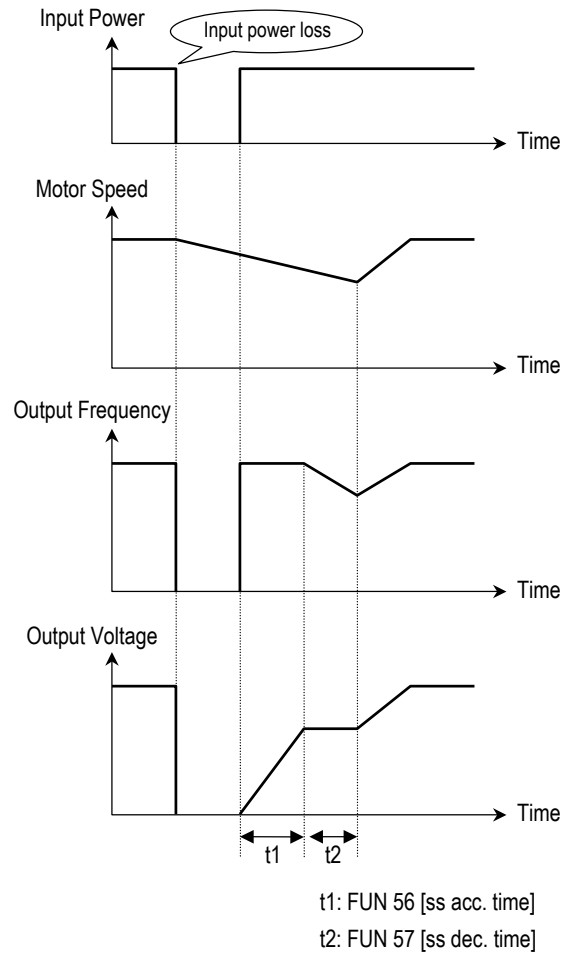

[IPF Restart and Speed Search]

FUN 59: Restart After Fault Reset Selection

```
FUN RST-restart
59      --- No ---
```

Setting Range: No, Yes
Factory Default: No

If [FUN 59] is set to 'Yes', inverter will restart after the RST (reset) terminal has been reset. If [FUN 59] is set to 'No', restart the inverter by cycling the FX terminal to CM terminal after the fault has been reset. If the motor is rotating at the time power is restored. The inverter may trip. To

avoid this trip, use 'Speed Search' function.

- **Caution:** When utilizing 'Reset Restart' make sure to utilize appropriate warning notices to minimize the potential for injury or equipment damage.

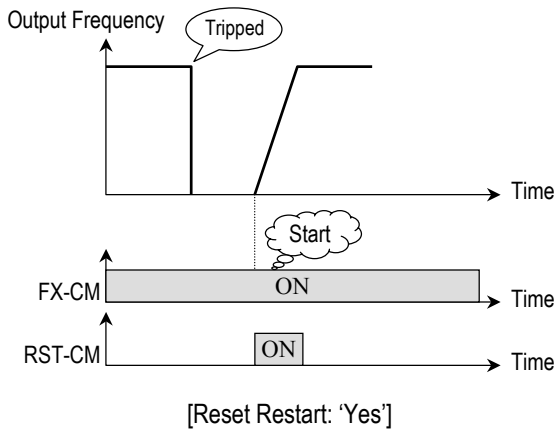
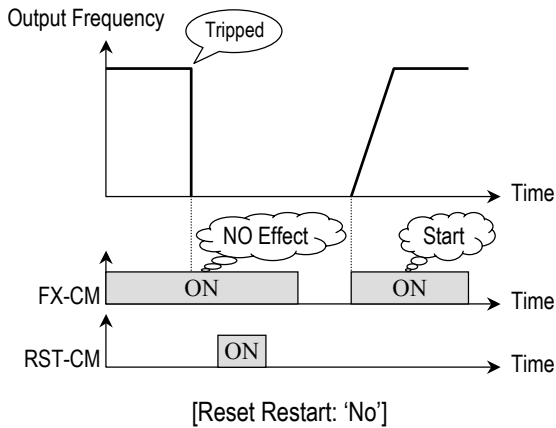

is rotating at the time power is restored. The inverter may trip. To avoid this trip, use 'Speed Search' function.

FUN 60: Restart After Power-On Selection

FUN	Power on st
60	--- No ---

Setting Range: No, Yes
Factory Default: No

If [FUN 60] is set to 'Yes', inverter will restart after input power has been restored. If [FUN 60] is set to 'No', restart the inverter by cycling the FX terminal after the fault has been reset. If the motor

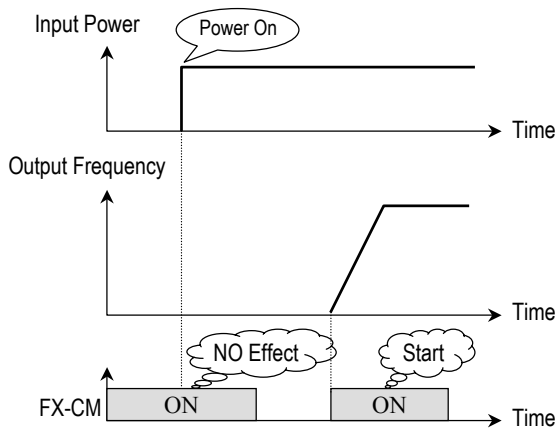

[Power On Start: 'No']

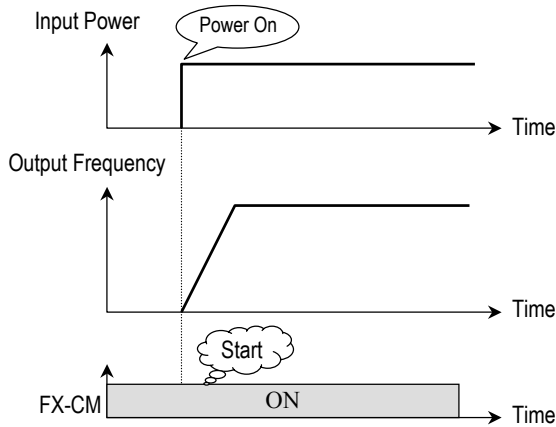

[Power On Start: 'Yes']

- **Caution:** When selecting 'Power-On Start' to 'Yes', make sure to utilize appropriate warning notices to minimize the potential for injury or equipment damage.

FUN 61: Carrier frequency

```
FUN Carrier Freq
61      6 kHz
```

Setting Range: See [FUN 61] in 'Parameter List'
Factory Default: 6kHz

This parameter sets the switching frequency for the PWM output. The switching frequency also affects the audible sound of the motor, emission from the

inverter, inverter temperature, and leakage current. If the ambient temperature where the inverter installed is high or other equipment may be affected by potential inverter noise, set this value lower. If the PWM frequency is high then audible noise from the motor will be reduced. The parameter can also be used to avoid induced resonances in the load or motor.

- FUN 62: PI Control Selection**
- FUN 63: Proportional Gain**
- FUN 64: Integral Gain**
- FUN 65: PI Feedback Signal Selection**
- FUN 66: PI Feedback Filtering Gain**
- FUN 67: PI Feedback Gain**
- FUN 68: PI Feedback Bias**
- FUN 69: PI Feedback Direction**
- FUN 70: I-Term Scale**
- FUN 71: PI Error Direction**
- FUN 72: PI Control Bypass**

For HVAC or Pump applications, the PID control can be used to adjust the actual output by comparing a feedback with a 'Set-point' given to the inverter. This 'Set-point' can be in the form of Speed, Temperature, Pressure, Flow level, etc. The 'Set-point' and the feedback signals are provided externally to the inverter analog input terminals V1, V2 or I. The inverter compares the signals in calculating 'total-error' which is reflected in the inverter output.

```
FUN  PI-control
62  --- No ---
```

Setting Range: No, Yes
Factory Default: No

This parameter selects PI control.

```
FUN  P-gain
63                                10
```

Setting Range: 1 to 30,000
Factory Default: 10

Sets the proportional gain for PI control.

```
FUN  I-gain
64          50
```

Setting Range: 1 to 30,000
Factory Default: 50

Sets the integral gain for PI control.

```
FUN  PI-FB select
65          I
```

Setting Range: I, V1, V2
Factory Default: I

Selects the feedback signal for PI control.

```
FUN  PI-FB fit.G
66          25%
```

Setting Range: 1 to 100%
Factory Default: 25%

Selects the filtering gain for feedback signal.

```
FUN  PI-FB gain
67          100%
```

Setting Range: 50 to 250%
Factory Default: 100%

Selects the gain for feedback signal.

```
FUN  PI-FB bias
68          100%
```

Setting Range: 0 to 200%
Factory Default: 100%

Selects the bias for feedback signal.

```
FUN  PI-FB dir
69          Direct
```

Setting Range: Direct, Invert
Factory Default: Direct

Selects the direction of feedback signal.

```
FUN  I_term scale
70          100%
```

Setting Range: 0 to 100%
Factory Default: 100%

Used to scale [FUN 64].

```
FUN  PI error dir
71          Direct
```

Setting Range: Direct, Invert
Factory Default: Direct

Used to change the polarity of error (command – feedback).

```
FUN  Regul bypass
72          --- No ---
```

Setting Range: No, Yes
Factory Default: No

When selected to ‘Yes’, inverter bypasses PI control and operates with frequency reference of feedback

FUN 94: CT/VT Mode Selection

```
FUN  CT/VT
94    Contant Trq
```

Setting Range: Constant Trq, Variable Trq
Factory Default: Constant Trq

This parameter selects ‘Constant Torque’ or ‘Variable Torque’. If ‘Variable Torque’ is selected, All current related parameters are changed to VT rating. (Overload Capacity, Carrier Frequency, Stall Prevention Level, Overload Warning Level, and Over Current-Limit Trip Level).

FUN 95: Parameter Upload to Keypad

```
FUN Para. read
95 --- No ---
```

Setting Range: No, Yes
Factory Default: No

This parameter is used to copy all parameters from the inverter to the keypad.

FUN 96: Parameter Download to Inverter

```
FUN Para. write
96 --- No ---
```

Setting Range: No, Yes
Factory Default: No

This parameter is used to copy all parameters from the keypad to the inverter.

FUN 97: Initialize Parameters to Factory Setting

```
FUN Para. init
97 --- No ---
```

Setting Range: No, Yes
Factory Default: No

This parameter returns all of the inverter parameters to their original settings.

- **Note:** Initializing the parameters to factory default settings also reinitializes the Inverter Capacity parameter [FUN 41]. Once the parameters are initialized to their factory defaults, [FUN 41] must be

set to its proper model number.

FUN 98: Parameter Lockout

```
FUN Para. lock
98 0
```

Setting Range: 0 to 255
Factory Default: 0

This function will prevent changes from being made to the parameters set in the drive. When the parameters are locked, the display arrow changes from solid to dashed line. The lock and unlock code is '12'.

```
FUN Para. lock
98 0
```

Blank Page

5.3 I/O Group

I/O 00: Jump to Desired Code

I/O	Jump Code
00	1

Setting Range: 1 to 65

Factory Default: 1

Jumping directly to any program code can be accomplished by entering the desired code number.

I/O 01 - 06: Multi-Function Inputs (Terminals P1 ~ P6)

I/O	P1 Input
01	SPD_L

Factory Default: SPD_L

I/O	P2 Input
02	SPD_M

Factory Default: SPD_M

I/O	P3 Input
03	SPD_H

Factory Default: SPD_H

I/O	P4 Input
04	ACCT_L

Factory Default: ACCT_L

I/O	P5 Input
05	ACCT_M

Factory Default: ACCT_M

I/O	P6 Input
06	ACCT_H

Factory Default: ACCT_H

Multi-function input terminals can be defined for many different applications. The following table shows various definitions for them.

Setting Range	Description
SPD_L SPD_M SPD_H	Multi-Step Speed via P1~P6
JOG	Jog
ACCT_L ACCT_M ACCT_H	Multi-Accel/Decel Time Select
UP	Increase Drive Output Frequency
DOWN	Decrease Drive Output Frequency
HOLD	Hold Drive Output Frequency
DIS_OPT	Disable Option Control
COMM_CONN	Connect Motor to Commercial Line
EXT_DCBR	Initiate Dynamic Braking Mode
EXT_TRIP	Initiate External Fault
INTERLOCK	Used for MMC Option

SPD_L, SPD_M, SPD_H: [Multi-Step Speed]

By setting P1, P2 and P3 terminals to 'SPD_L', 'SPD_M', and 'SPD_H' respectively, the inverter can operate at the preset frequency set in [I/O 13] through [I/O 19].

The preset frequencies are determined by the combination of P1, P2 and P3 terminals as shown in the following table.

Multi-Step Speed Selection Table

	Speed 0	Speed 1	Speed 2	Speed 3	Speed 4	Speed 5	Speed 6	Speed 7
SPD_L	0	1	0	1	0	1	0	1
SPD_M	0	0	1	1	0	0	1	1
SPD_H	0	0	0	0	1	1	1	1

0: OFF, 1: ON

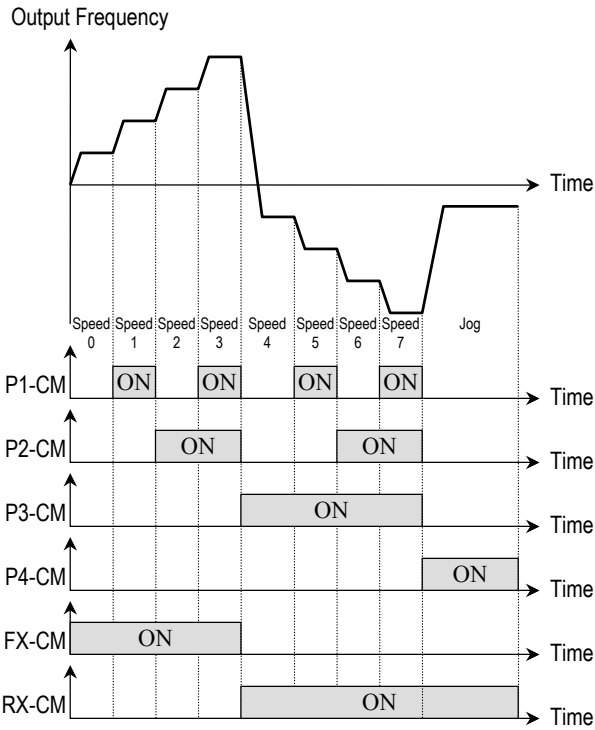

[Multi-Step Speed Operation]

- **Note:** [I/O 12] (Jog Frequency) can be used as one of the step frequencies.
- **Note:** If the 'Jog' terminal is ON, inverter operates at the Jog frequency regardless of other terminal inputs.

JOG:

Jog Frequency can be used as one of the step frequencies. Jog frequency is set in I/O 12.

ACCT_L, ACCT_M, ACCT_H: [Multi-Step Acceleration/Deceleration Time]

By setting multi-function input terminals to 'ACCT_L', 'ACCT_M' and 'ACCT_H' respectively, up to 7 different Accel and Decel times can be used. The Accel/Decel time is set in [I/O 20] through [I/O 33]

The Accel/Decel time is determined by the combination of multi-function input terminals as shown in the following table.

Multi-Step Accel/Decel Time Selection Table

	Time 0	Time 1	Time 2	Time 3	Time 4	Time 5	Time 6	Time 7
ACCT_L	0	1	0	1	0	1	0	1
ACCT_M	0	0	1	1	0	0	1	1
ACCT_H	0	0	0	0	1	1	1	1

0: OFF, 1: ON

The Time 0 Accel/Decel time is configured by DRV 01-02 and selected when no Accel/Decel input terminals are active.

Example:

If P4 is configured as ACC_L, P5 as ACCT_M and P6 as ACCT_H, then P4, P5 and P6 terminals can select the transition time.

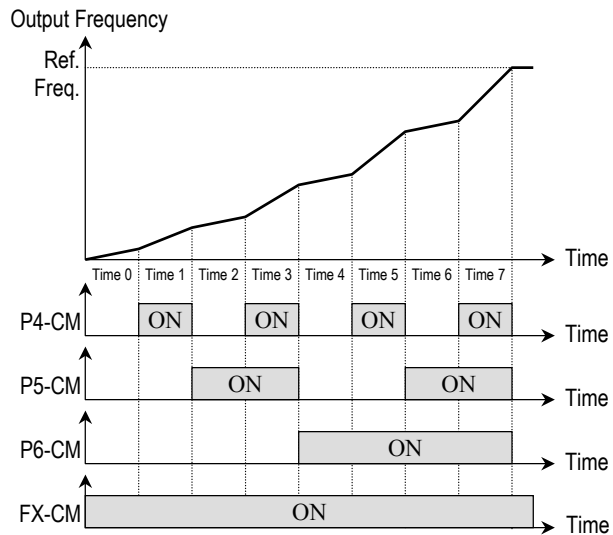

[Multi-Accel/Decel Time Operation]

UP, DOWN:

By using the Up and Down function, the drive can accelerate to a steady speed and decelerate down to a desired speed by using only two input terminals.

Example:

If P1 is configured as 'UP' and P2 as 'DOWN', then Up/Down operation can be achieved using P1 and P2 terminals.

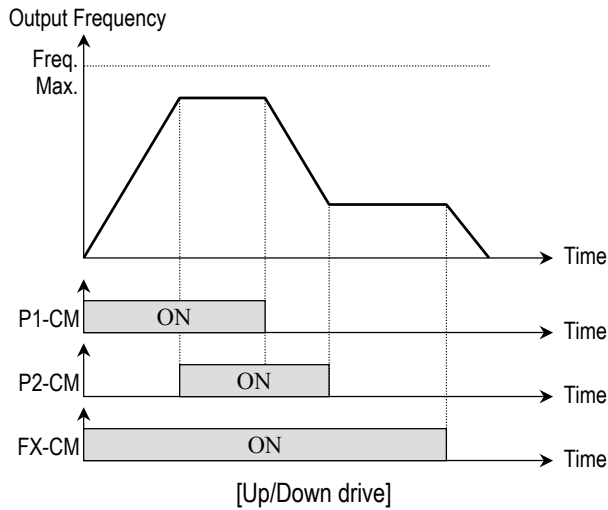

HOLD:

This function is for 3-wire start/stop control. This parameter is mainly used as a momentary push button to hold the current frequency output during acceleration or deceleration.

Example:

When P2 is configured as 'HOLD'.

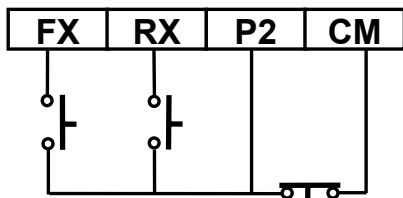

[Wiring for 3-Wire Operation]

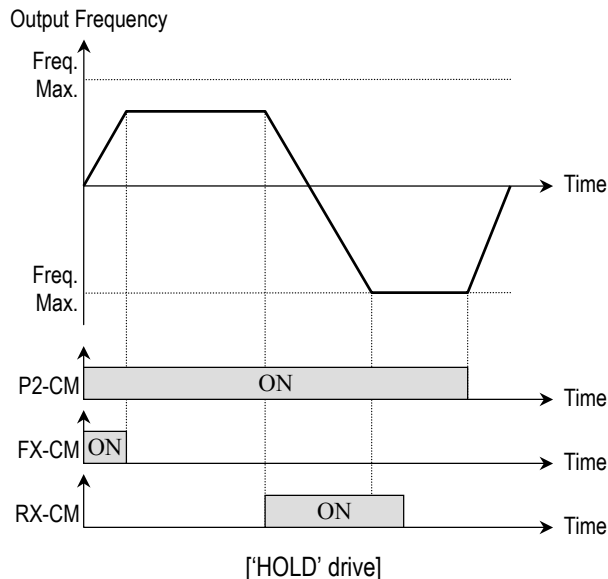

DIS_OPT: This function is used to exchange

control mode from Option Board to Inverter.

COMM_CONN:

This function is used to bypass the motor from the inverter to commercial power, or the opposite. To bypass the motor to commercial line, set [FUN 01] to either 'Key' or 'Terminal'. Set the Run and Stop method to 'Terminal-1' in [FUN 02]. Configure P5 as 'COMM_CONN' in [I/O 10]. To bypass the motor input from the inverter, close the P5 terminal to CM.

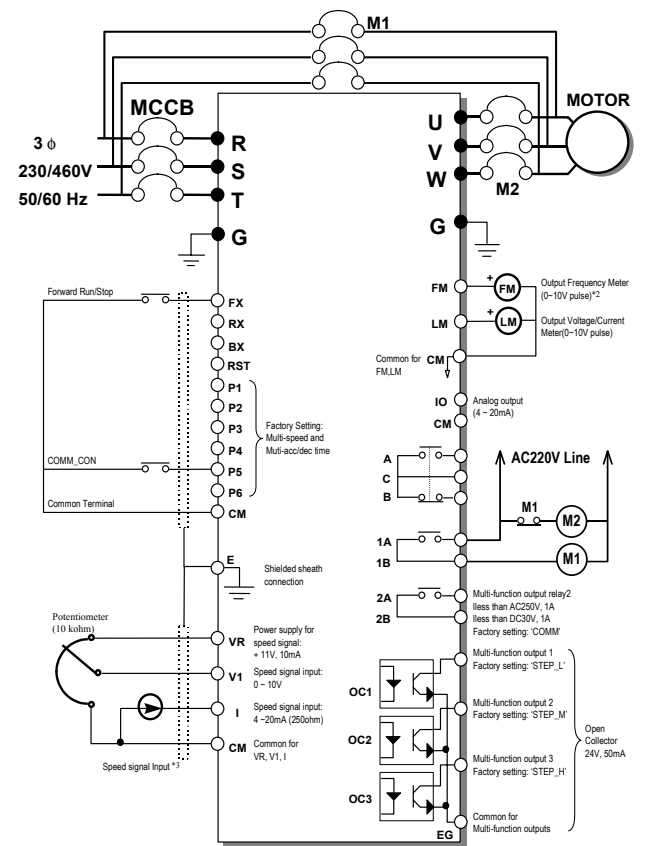

[Wiring for 'COMM_CONN']

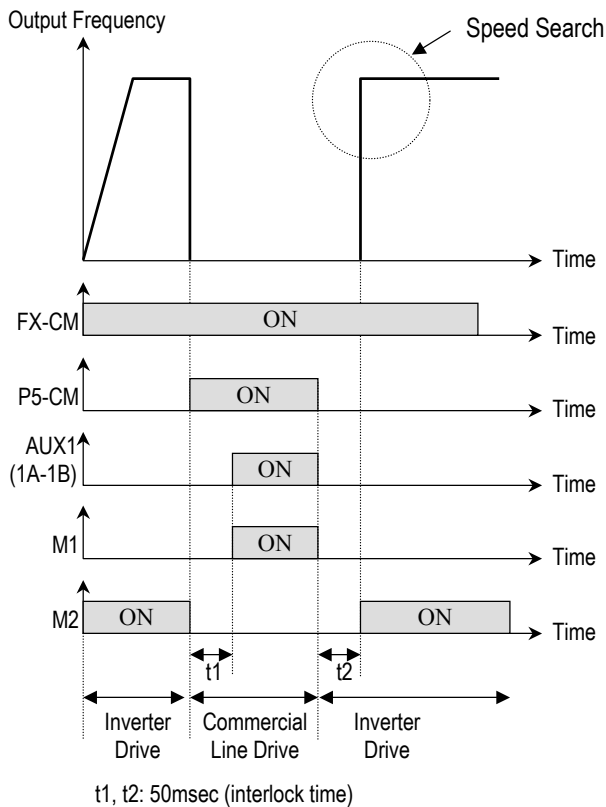

['COMM_CONN' Sequence]

EXT_DCBR:

DC Injection Braking can be activated, while the inverter is stopped, by configuring one of the multi-function input terminals to 'EXT_DCBR'. To activate the DC Injection Braking, close the contact on the assigned terminal while the inverter is stopped.

Example:

If P4 is configured as EXT_DCBR, then DC injection braking is achieved on stop by using P4 input terminal.

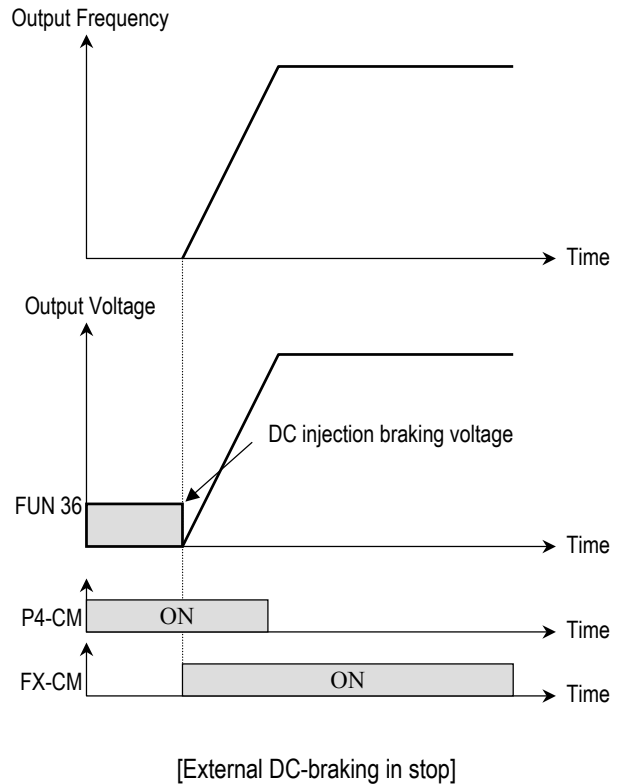

EXT_TRIP:

This is a normally closed contact input. When an input terminal is set to 'EXT_TRIP' and the contact input opens, the inverter displays the fault and cuts off its output. This can be used as an external latch trip. The inverter will decelerate as configured in [FUN 15]. The inverter must be RESET and the RUN command must be re-initiated to restart the drive.

I/O 07 - 11: Multi-function Outputs (OC1, OC2, OC3, AUX1, AUX2)

I/O[◊] OC1 output
07 STEP_L

Factory Default: STEP_L

I/O[◊] OC2 output
08 STEP_M

Factory Default: STEP_M

I/O	OC3 output
09	STEP_H

Factory Default: STEP_H

I/O	AUX1 output
10	COMM

Factory Default: COMM

I/O	AUX2 output
11	COMM

Factory Default: COMM

Setting Range:

- FST_LO
- FST_HI
- FDT_HI
- FDT_PULSE
- FDT_BAND
- OL
- STALL
- LV
- RUN
- COMM
- STEP_L
- STEP_M
- STEP_H

Multi-Function outputs OC1, OC2 and OC3 are open collector outputs and can be defined by the user. AUX1 and AUX2 are auxiliary relay outputs.

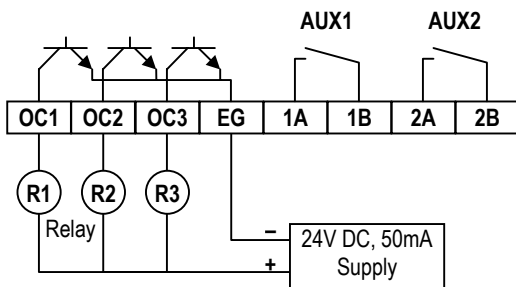

[Multi-Function Output Terminal Configuration]

FST_LO:

During acceleration, deceleration, and constant speed conditions, the inverter can generate an output signal via the multi-function output terminals whenever its output frequency is below the value in [I/O 38].

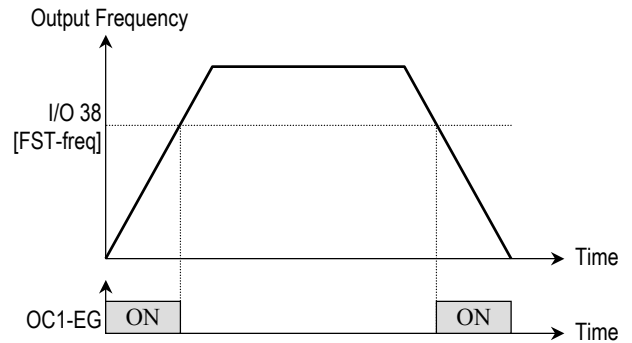

[OC1 Configured as 'FST-LO']

FST_HI:

The inverter can generate an output signal via the multi-function output terminals whenever its output frequency is above the value in [I/O 38].

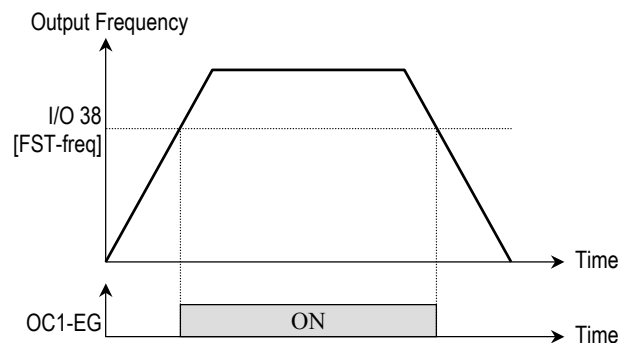

[OC1 Configured as 'FST-HI']

FDT_HI:

The inverter can generate an output signal via the multi-function output terminals whenever its output frequency is above the Frequency Detection Level set in [I/O 39]. The output is turned off when the output frequency goes below the Frequency Detection Level frequency minus the Frequency Detection Bandwidth [I/O 40].

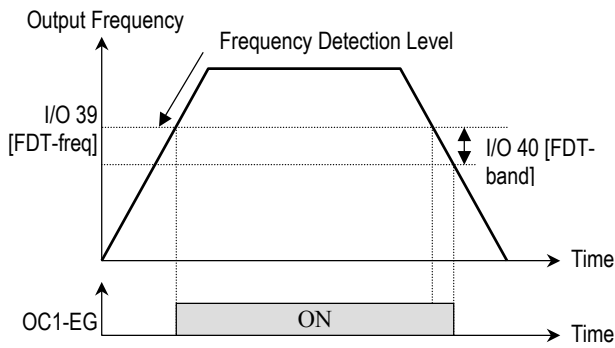

[OC1 Configured as 'FDT-HI']

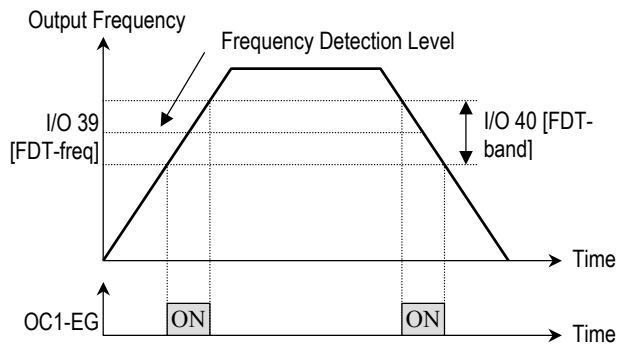

[OC1 Configured as 'FDT-BAND']

FDT_PULSE:

The inverter can generate a pulsed output signal for 100ms via the multi-function output terminals when its output frequency is above the Frequency Detection Level set in [I/O 39]. The output is pulsed again when the output frequency goes below the Frequency Detection Level frequency minus the Frequency Detection Bandwidth [I/O 40].

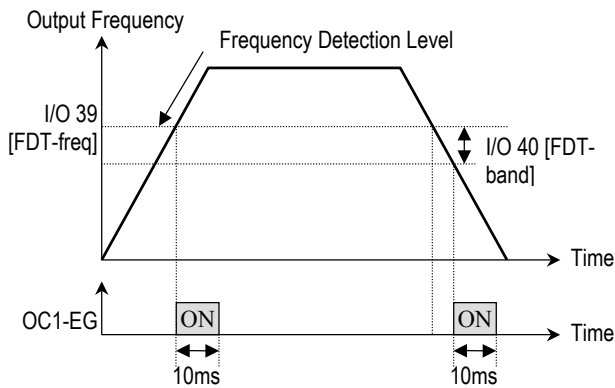

[OC1 Configured as 'FDT-PULSE']

FDT_BAND:

The inverter can generate an output signal via the multifunction output terminals whenever its output frequency falls within its programmed bandwidth [I/O 40]. The output is turned off when the output frequency goes outside the Frequency Detection Bandwidth centered on the Frequency Detection Level frequency.

OL: [Overload Signal]

When the output current is above the overload warning level set in FUN 47 [OL level] for overload duration time set in FUN 48 [OL time], the inverter can generate an output signal via the multi-function output terminals. The output signal will turn off once the current output level falls below the value of [FUN 47] and hold for more than half of the time set in [FUN 48].

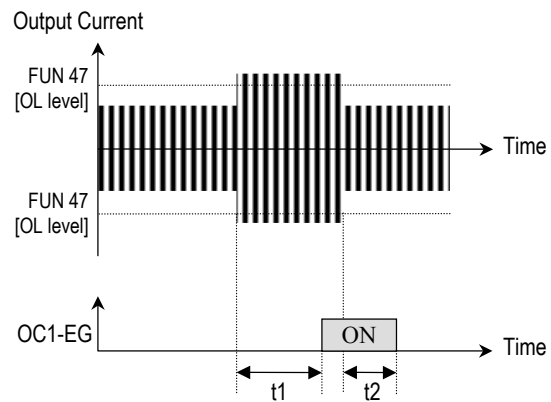

t1: Overload warning time - FUN 48 [OL time]
t2: Overload warning time / 2

[OC1 Configured as 'OL']

STALL:

Whenever the inverter stalls, the inverter can generate an output signal via the multi-function output terminals. This is true throughout acceleration, deceleration and steady state conditions.

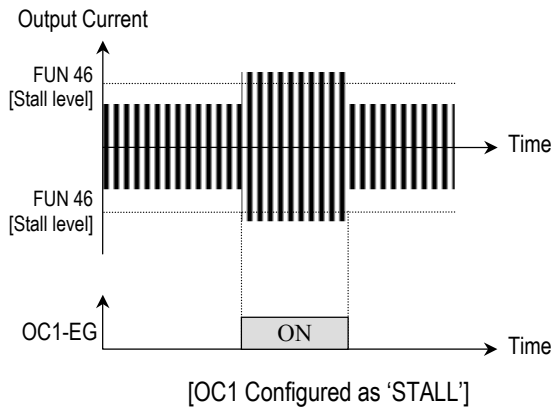

LV: [Low voltage]

Whenever the inverter's DC Link Voltage falls below the under voltage of the drive, the inverter can generate an output signal via the multi-function output terminals.

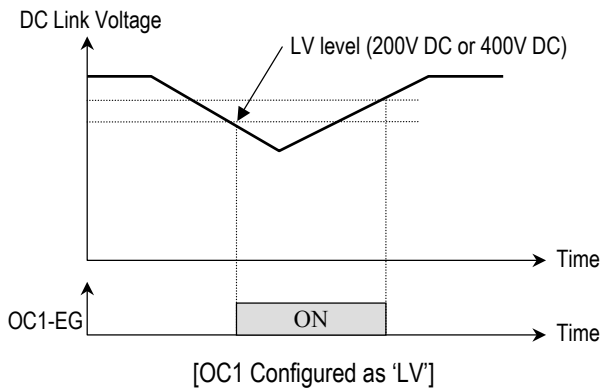

RUN: [On Running]

Whenever the inverter is in the Run Mode, the inverter can generate an output signal via the multi-function input terminals.

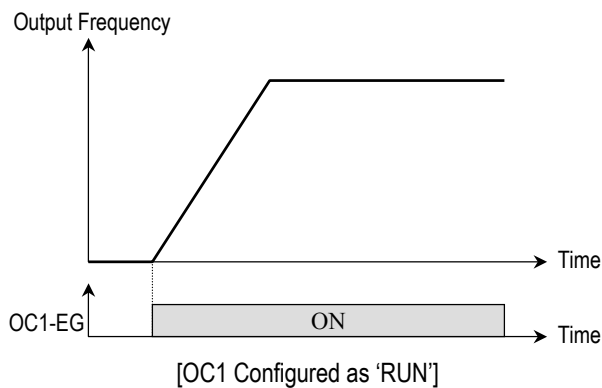

COMM:

Whenever the inverter is in a Bypass Mode, the inverter can generate an output signal via the multi-function output terminals.

STEP_L, STEP_M, STEP_H:

The inverter can generate an output signal via the multi-function output terminals for monitoring STEP commands. The output signal is in binary format as set by input terminals [I/O 01] through [I/O 06] via the OC1, OC2 and OC3 terminals.

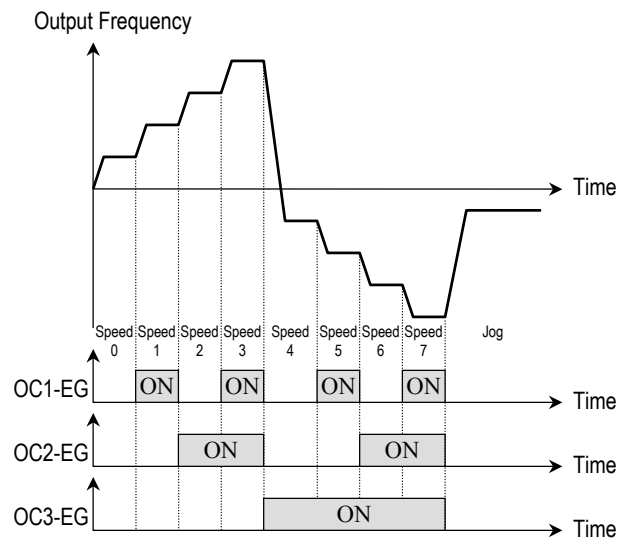

[OC1 Configured as 'STEP_L',
OC2 Configured as 'STEP_M',
OC3 Configured as 'STEP_H']

I/O 12: Jog Frequency

I/O Jog freq.
12 30.00 Hz

Setting Range: 0 to FUN 04
Factory Default: 30Hz

The Jog Frequency can be used to inch the drive Forward or Reverse.

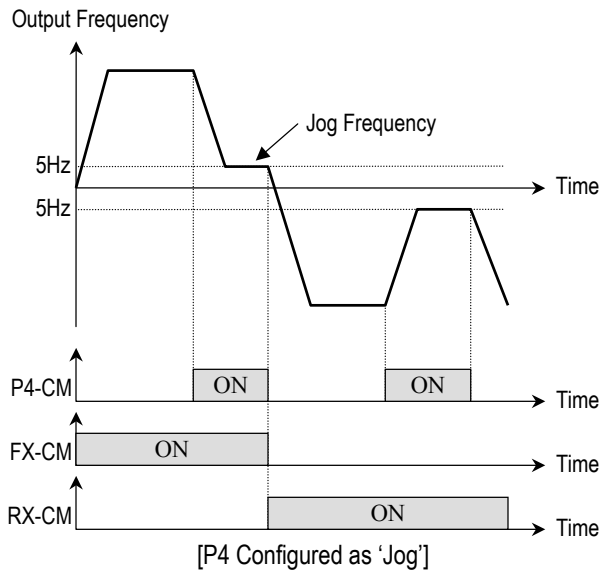

I/O 13 - 19: Multi-Step Frequency

I/O Step freq-1
13 10.00 Hz

•
•
•

I/O Step freq-7
19 37.00 Hz

Setting Range: 0 to 400Hz (FUN 04)

Up to 7 preset Step Frequencies may be selected in [I/O 13] through [I/O 19]. See multi-function input terminal selection for more detail.

I/O 20 - 33: Multi-Step Accel/Decel Time

I/O Acc time-1
20 1.0sec

I/O Dec time-1
21 1.0sec

•
•

I/O Acc time-7
32 7.0sec

I/O Dec time-7
33 7.0sec

Setting Range: 0 to 6000sec

Up to 7 preset Accel/Decel times may be selected in [I/O 20] through [I/O 33]. See multi-function input terminal selection for more detail.

I/O 34: Load Meter (LM) Selection

I/O 35: Load Meter (LM) Adjustment (15V Pulse)

I/O LM meter
34 Voltage

Setting Range: Voltage, Current
Factory Default: Voltage

I/O LM adj.
35 100 %

Setting Range: 0 to 120%
Factory Default: 100%

[I/O 34] selects either voltage or current to be displayed on the inverter's load meter. Output for the meter is a pulsed 0~10VDC. This output voltage may be adjusted in [I/O 35].

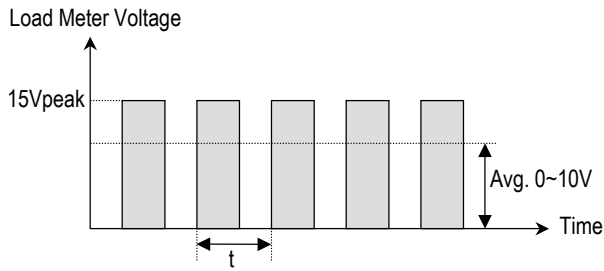

[Load Meter (LM-CM Terminal) Output]

Load Meter Frequency (1/t) = 1.8kHz

Duty (%) = (Output Voltage / Maximum Output Voltage) * 2/3

Or = (Output Current / Rated Current * 1.5) * 2/3

Load Meter Voltage = (Output Voltage / Maximum Output Voltage) * 10V

Or = (Output Current / Rated Current * 1.5) * 10V

I/O 36: Frequency Meter (FM) Adjustment (15V Pulse)

I/O	FM adj.
36	100 %

Setting Range: 0 to 120%

Factory Default: 100%

[I/O 36] adjust 0~10VDC pulsed frequency meter display signal on the FM terminal.

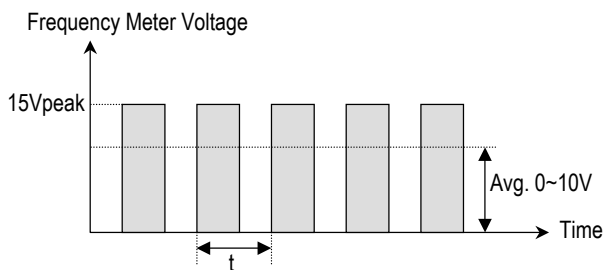

[Frequency Meter (FM-CM Terminal) Output]

Frequency meter frequency (1/t) = (Output Frequency / Maximum Output Frequency) * 1.8kHz

Duty (%) = (Output Voltage / Maximum Output Voltage) * 2/3

Frequency Meter Voltage = (Output Voltage / Maximum Output Voltage) * 10V

I/O 37: IO Meter Adjustment (4~20mA)

I/O	IO adj.
37	100 %

Setting Range: 0 to 120%

Factory Default: 100%

IO meter displays the inverter's output frequency as a current signal on the IO terminal. The current signal is 4~20mA. To adjust the current signal value, change [I/O 37] to the proper setting. The following equation may be used to determine the proper output.

IO Meter Current = 4mA + (Output Frequency / Maximum Frequency) * 16mA

I/O 38: Frequency Steady Level

I/O 39: Frequency Detection Level

I/O 40: Frequency Detection Bandwidth

I/O	FST-freq.
38	0.05 Hz

Setting Range: 0.5 to 400Hz (FUN 04)

Factory Default: 0.05Hz

I/O	FDT-freq.
39	60.00 Hz

Setting Range: 0.5 to 400Hz (FUN 04)

Factory Default: 60Hz

I/O	FDT-freq.
40	1.00 Hz

Setting Range: 0.5 to 30 Hz

Factory Default: 1Hz

[I/O 38] through [I/O 40] are used in connection with multi-function output [I/O 07] through [I/O

11].

I/O 41: Speed Display Multiplier Factor
I/O 40: Speed Display Divider Factor

I/O# Ter. input
 41 100

Setting Range: 0 to 999
Factory Default: 100

I/O# Ter. output
 42 100

Setting Range: 1 to 999
Factory Default: 100

[I/O 41] and [I/O 42] are used to translate [DRV 04] into line or process speed. Motor poles are defined in [FUN 54]. The following equation may be used to determine the proper output.

$$\text{Line Speed} = \frac{\text{Multiplier Factor}}{\text{Divide Factor}} \times \frac{120 * \text{Output Frequency}}{P \text{ (Number of Poles)}}$$

I/O 43: Input Terminal Status
I/O 44: Output Terminal Status

I/O# Ter. input
 43 1000000001

I/O# Ter. output
 44 10001

[I/O 43] and [I/O 44] displays the status of FX, RX, P1 – P6 input terminals and OC1, OC2, OC3, AUX1 (1A, 1B) and AUX2 (2A, 2B) output terminals.

Input Terminal Status

P6	P5	P4	P3	P2	P1	X	X	RX	FX
----	----	----	----	----	----	---	---	----	----

1	0	0	0	0	0	0	0	0	0	1
---	---	---	---	---	---	---	---	---	---	---

0: OFF, 1: ON

Output Terminal Status

AUX2	AUX1	OC3	OC2	OC1
1	0	0	0	1

0: OFF, 1: ON

I/O 45: Software Version

I/O# S/W version
 45 2.02

[I/O 45] displays the software version of the inverter.

I/O 46: Fault History 1
I/O 47: Fault History 2

I/O Last fault 1
 46 OV Trip

I/O Last fault 2
 47 OC Trip

[I/O 46] and [I/O 47] review trip information. By using keypad, trip information (Over Current, Over Voltage and Frequency) may be displayed.

Example:

By using the PROG, UP and DOWN arrow key, old trip information (which contains current, frequency and trip) can be viewed.

I/O Last fault 1
 46 OV Trip

I/O Last fault 1
 46 35.60 Hz

I/O Last fault 1
 46 16.5 A

```
I/O Last fault 2
47      OC Trip
```

```
I/O Last fault 2
47      60.00 Hz
```

```
I/O Last fault 2
47      50.6 A
```

I/O 48: Option 1 Selection
I/O 49: Option 2 Selection

```
I/O Option 1
48      None
```

```
I/O Option 2
49      None
```

Setting Range: **None**
 RS485
 Modbus RTU
 F-Net
 Device Net

[I/O 48] and [I/O 49] allows the selection of available option cards for the inverter.

None:

This option indicates NO option cards are used in the inverter.

RS485:

This option card allows communication between the inverter and a computer using the inverter's software protocol. For more detailed information, see RS485 option manual.

Modbus RTU:

This option card allows communication between the inverter and a computer using Modbus RTU protocol. For more detailed information, see Modbus RTU option manual.

Fnet:

This option card allows communication between the inverter and LG GLOFA PLC using exclusive protocol. For more detailed information, see Fnet option manual.

Device Net:

This option card allows communication between the inverter and a computer using Device Net protocol. For more detailed information, see Device Net option manual.

I/O 50: Inverter ID Number

```
I/O Inv. number
50      1
```

Setting Range: 1 to 31
Factory Default: 1

[I/O 50] defines the inverter's unique ID number. This function is used when the RS485/Modbus RTU option card is selected.

I/O 51: Baud Rate

```
I/O Baud-rate
51      9600 BPS
```

Setting Range: 1200, 2400, 4800, 9600, 19200
Factory Default: 9600

[I/O 51] selects the baud rate used in inverter communication. This function is used when the RS485/Modbus RTU/Fnet option card is selected.

I/O 52: Communication Timeout

I/O Comm. Timeout
52 10.0sec

Setting Range: 0 to 60sec
Factory Default: 10sec

[I/O 52] selects the time by which the inverter determines communication error between the inverter and option card. This function is used when the RS485/Modbus RTU/Fnet option card is selected.

I/O 53: PG Slip Frequency

I/O PG Slip Freq
53 5.00 Hz

Setting Range: 0 to 10Hz
Factory Default: 5Hz

[I/O 53] selects the slip frequency when using the 'PG' Encoder option card.

I/O 54: PG P-Gain

I/O PG. P-Gain
54 10

Setting Range: 0 to 255
Factory Default: 10

[I/O 54] establishes the proportional gain when using the 'PG' Encoder option card.

I/O 55: PG I-Gain

I/O PG. I-Gain
55 30

Setting Range: 0 to 255
Factory Default: 30

[I/O 55] establishes the integral gain when using the 'PG' Encoder option card.

I/O 56: PG Filter Gain

I/O PG. F-Gain
56 100

Setting Range: 0 to 255
Factory Default: 100

[I/O 56] establishes the filter gain when using the 'PG' option card.

I/O 57: Encoder Pulse Selection

I/O Enc pulse
57 512 Pulse

Setting Range: 100, 500, 512, 1000, 1024, 2000, 2048, 4000 pulse
Factory Default: 512 Pulse

[I/O 57] establishes the number of encoder pulses per revolution when using the 'PG' Encoder option card.

I/O 58: Digital Input Selection

I/O DI Mode
58 None

Setting Range: None, Freq. 1, Freq. 2
Factory Default: None

[I/O 58] selects the type of 12-bit digital input when using the 'DI_DA' option card.

I/O 59: Analog Output Selection

I/O	DA Mode
59	Freq.

Setting Range: Freq., Voltage, Current
Factory Default: Freq.

[I/O 59] selects Frequency, Voltage of Current for the inverter output signal when using the 'DI_DA' option card.

I/O 60: Analog Output Adjustment

I/O	DA adj.
60	100 %

Setting Range: 80 to 120%
Factory Default: 100%

[I/O 60] calibrates the 4~20mA output signal when using 'DI_DA' option card.

I/O 61: Inverter Number for Fnet

I/O	FN:St.	ID
61		1

Setting Range: 1 to 63
Factory Default: 1

[I/O 61] defines the inverter's unique ID number. This function is used when the Fnet option card is selected.

I/O 62: Inverter Number for Device Net

I/O DN: MAC	ID
62	0

Setting Range: 0 to 63
Factory Default: 0

[I/O 62] defines the inverter's unique ID number. This function is used when the Device Net option card is selected.

I/O 63: Baud Rate for Device Net

I/O DN: BaudRate
63 125 kbps

Setting Range: 125, 250, 500 kbps
Factory Default: 125 kbps

[I/O 63] selects the baud rate used in inverter communication. This function is used when the Device Net option card is selected.

I/O 64: Device Net Output Instance

I/O DN: Out Inst
64 Instance 20

Setting Range: 20, 21, 100, 101
Factory Default: 20

[I/O 64] selects the output instance used in inverter communication. This function is used when the Device Net option card is selected.

I/O 65: Device Net Input Instance

I/O DN: In Inst
65 Instance 70

Setting Range: 70, 71, 110, 111
Factory Default: 70

[I/O 65] selects the input instance used in inverter communication. This function is used when the Device Net option card is selected.

CHAPTER 6 - TROUBLESHOOTING & MAINTENANCE

6.1 Fault Display

When a fault occurs, the inverter turns off its output and displays the fault status in [DRV 05]. The last 2 faults are saved in [I/O 46] and [I/O 47] with the operation status at the instance of fault.

Keypad Display	Protective Function	Description
OC Trip	Over Current Protection	The inverter turns off its output when the output current of the inverter is more than 200% of the inverter rated current.
GF Trip	Ground Fault Protection	The inverter turns off its output when a ground fault occurs and the ground fault current is more than the internal preset value of the inverter. The Over current trip function may protect the inverter when a ground fault occurs due to the low ground fault resistance.
OV Trip	Over Voltage protection	The inverter turns off its output if the DC voltage of the main bus increases higher than the rated value when the motor decelerates or when regenerative energy flows back to the inverter due to a regenerative load. This fault can also occur due to a surge voltage generated in the input power supply system.
OC Limit	Current Limit Protection (Overload Protection)	The inverter turns off its output if the output current exceeds the value set in [FUN 49] over the time period set in [FUN 50]
Fuse Open	Fuse Open	The inverter turns off its output by opening the fuse when something is wrong with the main power circuit IGBTs to protect the wiring from being damaged from short currents.
Over Heat	Heat Sink Over Heat	The inverter turns off its output if the heat sink overheats due to a damaged cooling fan or an foreign substance in the cooling path by detecting the temperature of the heat sink.
ETH	Electronic Thermal	The internal electronic thermal of the inverter determines the motor is over heating. If the motor is overloaded the inverter turns off the output. The inverter may not protect the motor when driving multiple motors, so consider thermal relays or other thermal protective devices for each motor. Overload capacity: Value set in [FUN 52]
EXT Trip	External Fault	Multi-function input configured as 'EXT_TRIP' has opened.
LV Trip	Low Voltage Protection	The inverter turns off its output if the DC bus voltage is below the preset level because insufficient torque production or over heating of the motor can occurs when the input voltage of the inverter drops.
SC Trip	IGBT Short	The inverter turns off the output if an IGBT shorts or an output short occurs.
BX	BX Protection (Instant Cut Off)	Used as an inverter disable. The inverter instantly turns off the output when the BX terminal is turned ON, and returns to regular operation when the BX terminal is turned OFF. Use caution when utilizing this function.
Inv. OLT	Inverter Overload	The inverter turns off its output when the output current of the inverter is more than the rated level overload level (150% for 1 minute CT, 200% for 0.5 seconds).
M/C Fail	Magnetic Contactor Fail	The inverter turns off its output if the magnetic contactor has failed or the CPT fuse has opened.

To reset fault, Press **RESET** key, Close RST-CM terminals or connect input power.

If a problem persists, please contact the factory or your local distributor.

Chapter 6 - Troubleshooting Maintenance

6.2 Fault Remedy

Protective Function	Cause	Remedy
Over Current Protection	<ol style="list-style-type: none"> 1) Acceleration/Deceleration time is too short compared to the inertia of the load 2) Load is larger than the inverter rating 3) Inverter turns output on when the motor is still rotating. 4) Output short or ground fault has occurred 5) Mechanical brake of the motor is operating too fast 6) Components of the main circuit have overheated due to a faulty cooling fan or blocked cooling. 	<ol style="list-style-type: none"> 1) Increase Accel/Decel time 2) Increase inverter capacity. 3) Operate after motor has completely stopped 4) Check output wiring 5) Check mechanical brake operation 6) Check cooling fan <p>(Caution) Operating inverter prior to correcting fault may damage the IGBT</p>
Ground Current Protection	<ol style="list-style-type: none"> 1) Ground fault has occurred at the output wiring of inverter. 2) The insulation of the motor has been damaged. 	<ol style="list-style-type: none"> 1) Investigate the output wiring of inverter 2) Exchange motor
Over Voltage Protection	<ol style="list-style-type: none"> 1) Deceleration time is too short compared to the inertia of load 2) Regenerative load at the output 3) Line voltage high 	<ol style="list-style-type: none"> 1) Increase deceleration time 2) Install Dynamic braking / resistor option 3) Check line voltage
Current Limit Protection (Overload Protection)	<ol style="list-style-type: none"> 1) Load is larger than the inverter rating 2) Selected incorrect inverter capacity parameter 3) Selected incorrect V/F pattern 	<ol style="list-style-type: none"> 1) Increase capacity of motor and/or inverter 2) Select correct inverter capacity 3) Select correct V/F pattern
Fuse Damage	<ol style="list-style-type: none"> 1) Damage due to repeated over current protection 2) Damage due to instant deceleration when motor is at an excessive excitation status. 	<p>Exchange the fuse</p> <p>(Caution) Many times the IGBTs are damaged when the Fuse Open Trip occurs and should be tested before returning the drive to service.</p>
Heat Sink Overheat	<ol style="list-style-type: none"> 1) Cooling fan damaged or a foreign substance is blocking fan 2) Cooling system has faults 3) Ambient temperature too high 	<ol style="list-style-type: none"> 1) Exchange cooling fans and/or eliminate foreign substance 2) Check for foreign substances in the heat sink 3) Keep ambient temperature under 40C
Electronic Thermal	<ol style="list-style-type: none"> 1) Motor has overheated 2) Load is larger than inverter rating 3) ETH level set too low 4) Incorrect inverter capacity selected 5) Set incorrect V/F pattern 6) Motor operated too long at low speeds 	<ol style="list-style-type: none"> 1) Reduce load and/or running duty 2) Increase inverter capacity 3) Adjust ETH level to an appropriate level 4) Select correct inverter capacity 5) Select correct V/F pattern 6) Install a cooling fan with a separate power supply
External Fault	External fault has occurred	Eliminate fault at circuit connected to external fault terminal or cause of external fault input
Low Voltage Protection	<ol style="list-style-type: none"> 1) Line voltage low 2) Load larger than line capacity is connected to line (welding machine, motor with high starting current connected to the commercial line) 3) Faulty magnetic switch at the input side of the inverter 	<ol style="list-style-type: none"> 1) Check line voltage 2) Increase line capacity 3) Exchange magnetic switch
IGBT Short	<ol style="list-style-type: none"> 1) Short has occurred between the upper and lower IGBT. 2) Short has occurred at the output of the inverter 3) Acceleration/Deceleration time is too short compared to the inertia of the load 	<ol style="list-style-type: none"> 1) Check IGBT 2) Check output wiring of inverter 3) Increase acceleration or deceleration time
Inverter Overload	<ol style="list-style-type: none"> 1) Load is larger than inverter rating 2) Selected incorrect inverter capacity 	<ol style="list-style-type: none"> 1) Increase motor and/or inverter capacity 2) Select correct inverter capacity
Magnetic	1) The magnetic contactor malfunction.	1) Replace the magnetic contactor

Protective Function	Cause	Remedy
Contactors Fail	2) The Control Power Transformer (CPT) fuse has opened.	2) Replace the CPT fuse

6.3 Troubleshooting

Condition	Check Point
The Motor Does Not Rotate	1) Main circuit inspection: <input type="checkbox"/> Is the input (line) voltage normal? (Is the LED in the inverter is lit?) <input type="checkbox"/> Is the motor connected correctly? 2) Input signal inspection: <input type="checkbox"/> Check the operating signal input to the inverter. <input type="checkbox"/> Check the forward and the reverse signal input simultaneously to the inverter? <input type="checkbox"/> Check the command frequency signal input to the inverter. 3) Parameter setting inspection: <input type="checkbox"/> Is the reverse prevention (FUN 03) function set? <input type="checkbox"/> Is the operation mode (FU1N 02) set correctly? <input type="checkbox"/> Is the command frequency set to 0? 4) Load inspection: <input type="checkbox"/> Is the load too large or is the motor jammed? (Mechanical brake) 5) Other: <input type="checkbox"/> Is the alarm displayed on the keypad or is the alarm LED lit? (STOP LED blinks)
The Motor Rotates in Opposite Directions	<input type="checkbox"/> Is the phase sequence of the output terminal U, V, W correct? <input type="checkbox"/> Is the starting signal (forward/reverse) connected correctly?
The Difference Between the Rotating Speed and the Reference is Too Large	<input type="checkbox"/> Is the frequency reference signal correct? (Check the level of the input signal) <input type="checkbox"/> Is the following parameter setting is correct? Lower Limit Frequency (FUN 27), Upper Limit Frequency (FUN 26), Analog Frequency Gain (FUN 20~23) <input type="checkbox"/> Is the input signal line influenced by external noise? (Use a shielded wire)
The Inverter Does Not Accelerate or Decelerate Smoothly	<input type="checkbox"/> Is the acceleration/deceleration time is set too short a period of time? <input type="checkbox"/> Is the load too large? <input type="checkbox"/> Is the Torque Boost (FUN 09~10) value is too high that the current limit function and the stall prevention function do not operate?
The Motor Current is Too High	<input type="checkbox"/> Is the load too large? <input type="checkbox"/> Is the Torque Boost Value (manual) too high?
The Rotating Speed Does Not Increase	<input type="checkbox"/> Is the Upper Limit Frequency (FUN 26) value correct? <input type="checkbox"/> Is the load too large? <input type="checkbox"/> Is the Torque Boost (FUN 09~10) value too high that the stall prevention function (FUN 45~46) does not operate?
The Rotating Speed Oscillates When the Inverter is Operating.	1) Load inspection: <input type="checkbox"/> Is the load oscillating? 2) Input signal inspection: <input type="checkbox"/> Is the frequency reference signal oscillating? 3) Other: <input type="checkbox"/> Is the wiring too long when the inverter is using V/F control? (Over 500m)

CAUTION
Risk of Electric Shock – More than one disconnect switch may be required to de-energize the equipment before servicing.

6.3.1 Motor Does Not RUN

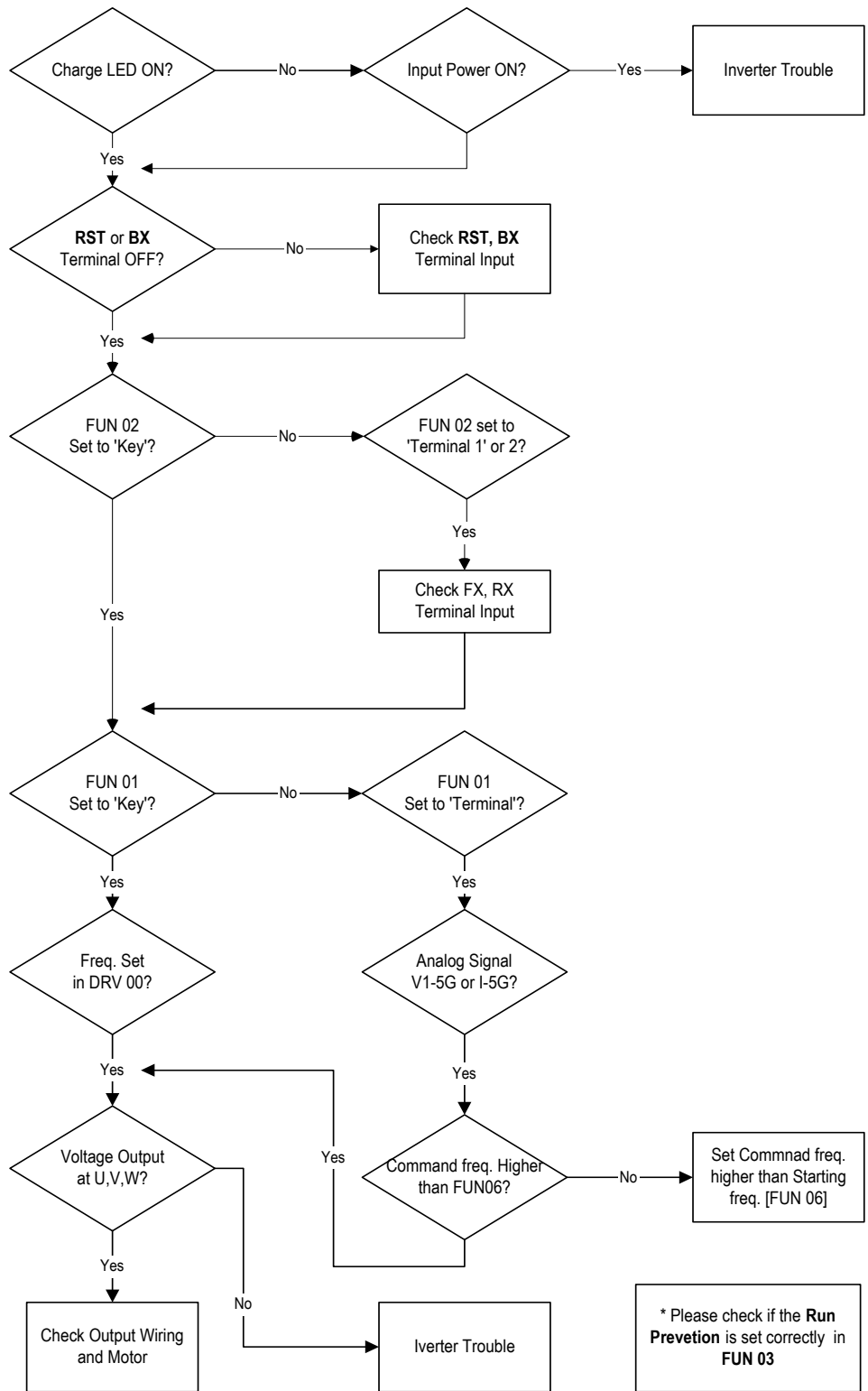

6.3.2 Motor Speed NOT EQUAL to the Command Frequency

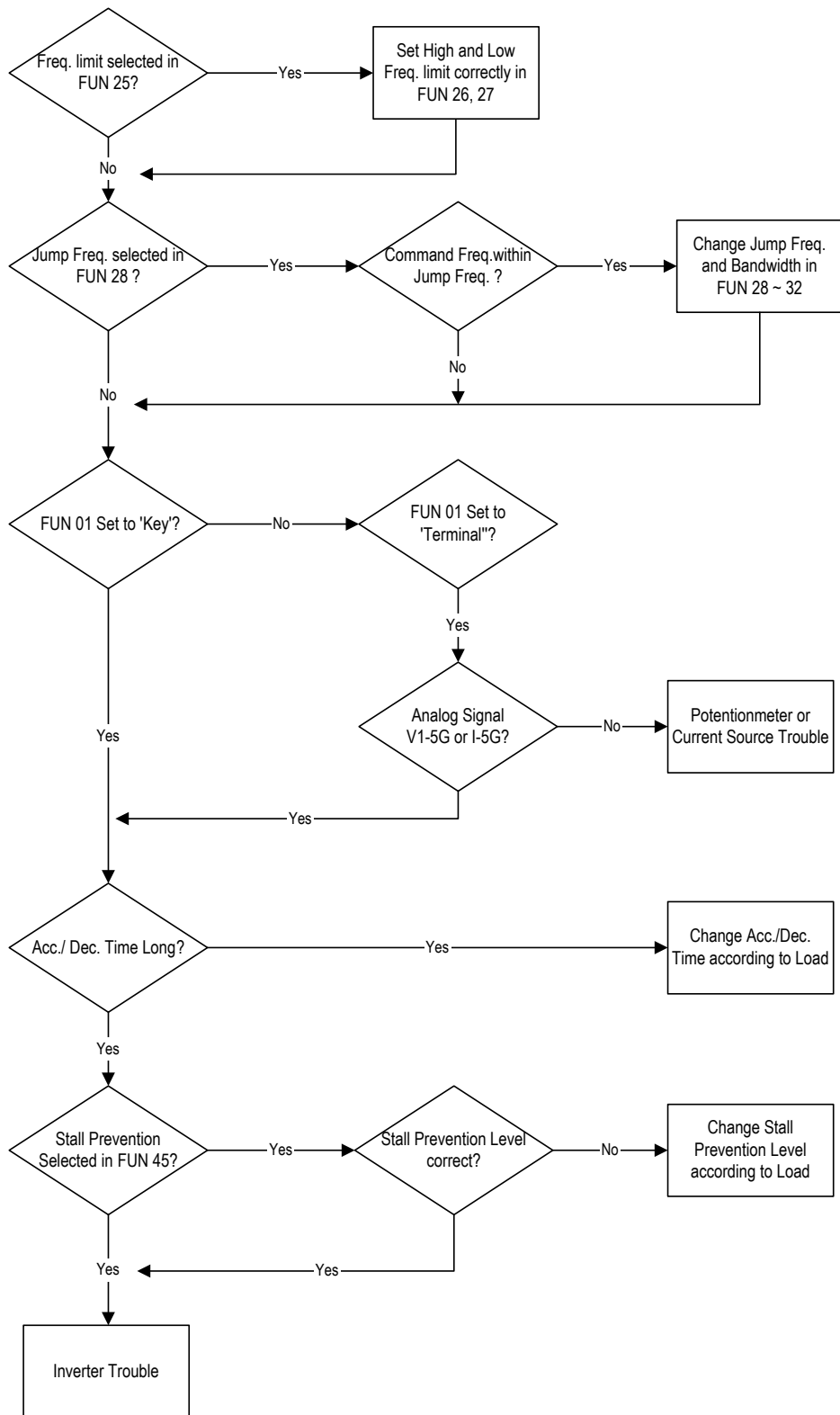

6.3.3 Motor Does Not Run Smoothly

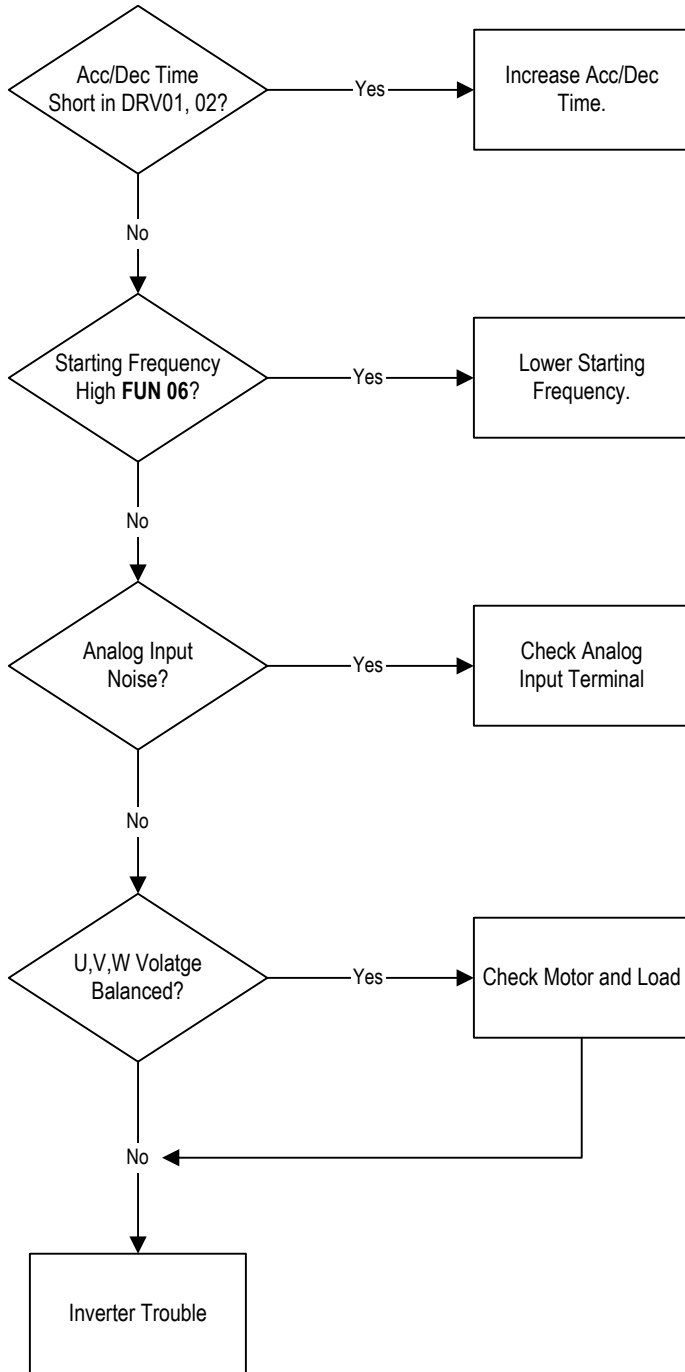

6.3.4 Motor Overheats

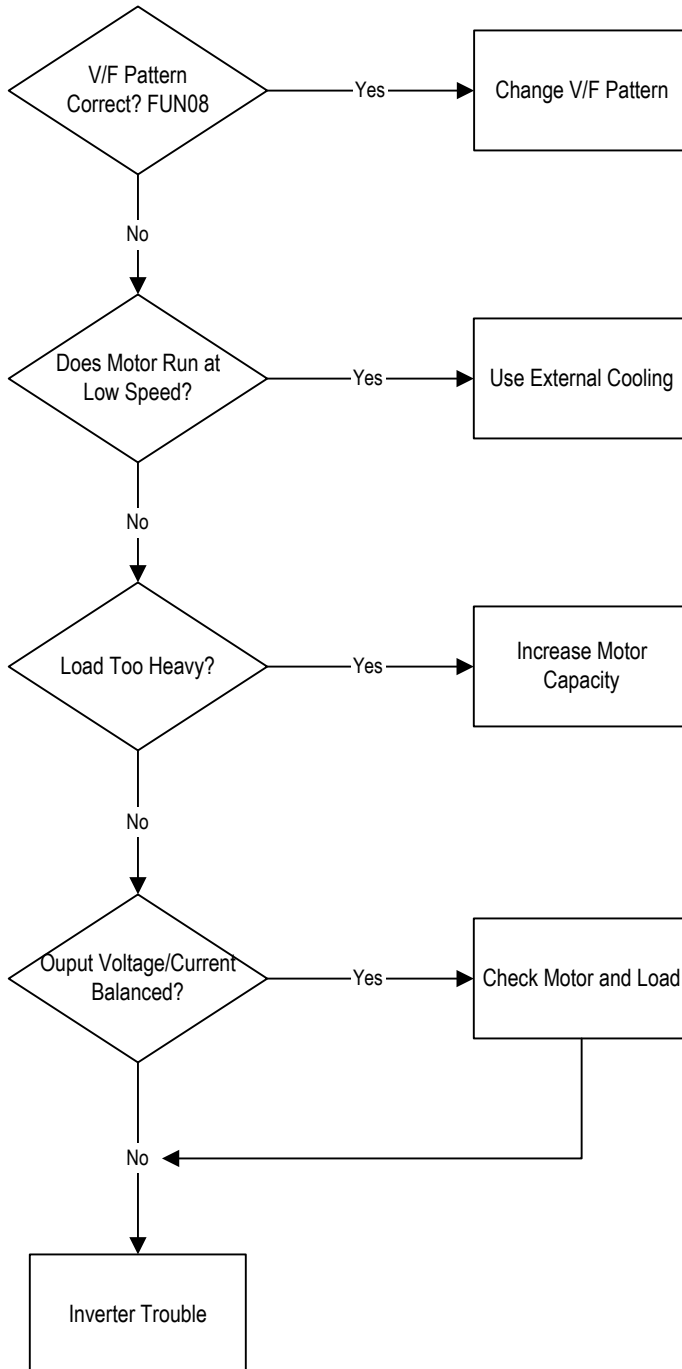

6.4 How to Check Power Components

Before checking the power components, be sure to disconnect AC Input supply and wait until the Main Electrolytic Capacitors (DCP-DCN) discharge.

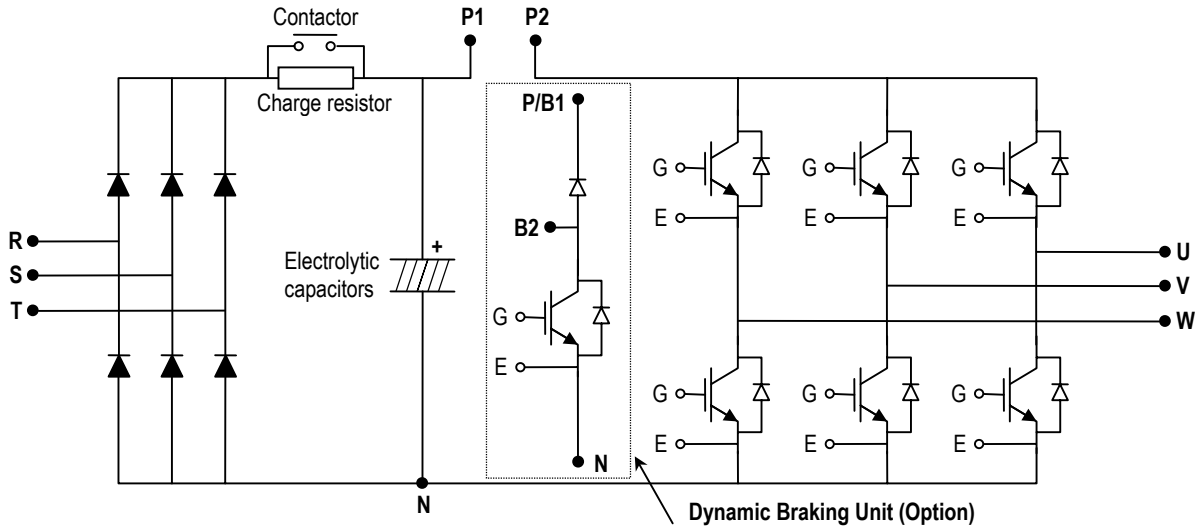

■ Diode Module Check

Check Point	Resistance
R, S, T – P1	50 k ohms or more
R, S, T – N	50 k ohms or more

■ Charge Resistor Check

Check Point	Resistance
Contactors terminals	Resistance depending on models

■ DB(Dynamic Braking) IGBT (Option)

Check Point	Resistance
B2 - N	50 k ohms or more
G - N	A few kilo ohms

■ IGBT Module Check

Check Point	Resistance
B2 - N	50 k ohms or more
G - N	A few kilo ohms

6.5 Maintenance

The H series drive is an industrial electronic product with advanced semiconductor elements. However, temperature, humidity, vibration and aging parts may still affect it. To avoid this, it is recommended to perform routine inspections.

6.5.1 Precautions

- Be sure to remove the drive power input while performing maintenance.
- Be sure to perform maintenance only after checking that the bus has discharged. The bus capacitors in the electronic circuit can still be charged even after the power is turned off.
- The correct output voltage can only be measured by using a rectifier voltage meter. Other voltage meters, including digital voltage meters, are likely to display incorrect values caused by the high frequency PWM output voltage of the drive.

6.5.2 Routine Inspection

Be sure to check the following before operation:

- The conditions of the installation location
- The conditions of the drive cooling
- Abnormal vibration
- Abnormal heating

6.5.3 Periodical Inspection

- Are there any loose bolt, nut or rust caused by surrounding conditions? If so, tighten up or replace them.
- Are there any deposits inside the drive-cooling fan? If so, remove using compressed air.
- Are there any deposits on the drive's PCB (Printed Circuit Boards)? If so, remove using compressed air.
- Are there any abnormalities in the various connectors of the drive's PCB? If so, check the condition of the connector in question.
- Check the rotating condition of the cooling fan, the size and condition of the capacitors and the connections with the magnetic contactor. Replace them if there are any abnormalities.

6.5.4 Internal Fuse Replacement

When the internal fuse is opened the IGBT's should be checked thoroughly before replacing the fuse. Contact the factory for replacement fuse information.

Chapter 6 - Troubleshooting Maintenance

6.6 Daily and Periodic Inspection Items

Inspection Location	Inspection Item	Inspection	Period			Inspection Method	Criterion	Measuring Instrument
			Daily	1 year	2 year			
All	Ambient Environment	Is there any dust? Is the ambient temperature and humidity adequate?	O			Refer to the precautions	Temperature: -10~+40 no freezing. Humidity: Under 90% no dew	Thermometer, Hygrometer, Recorder
	Equipment	Is there any abnormal oscillation or noise	O			Use sight and hearing	No abnormality	
	Input Voltage	Is the input voltage of the main circuit normal	O			Measure the voltage between the terminals R, S, T		Digital Multi-Meter/Tester
Main Circuit	All	Megger check (between the main circuit and the ground) Are any fixed parts removed? Are there any traces of overheating at each component's cleaning?		O	O	Undo the inverter connections short the terminals R, S, T, U, V, W and measure between these parts and the ground. Tighten the screws. Visual check.	Over 5MΩ No fault	DC 500V class Megger
	Conductor/Wire	Is the conductor rusty? Is the wire coating damaged?		O		Visual check	No fault	
	Terminal	Is there any damage?		O		Visual check	No fault	
	IGBT Module /Diode Module	Check the resistance between each of the terminals.			O	Undo the inverter connection and measure the resistance between R, S, T □ P, N and U, V, W □ P, N with a tester.	(Refer "How to Check Power Components")	Digital Multi-Meter/Analog Tester
	Smoothing Capacitor	Is there any liquid coming out? Is the safety pin out, and is there any swelling? Measure the capacitance.	O	O		Visual check. Measure with a capacitance-measuring device.	No fault Over 85% of the rated capacity	Capacitance Measuring Device
	Relay	Is there any chattering noise during operation? Is there any damage to the contact		O		Auditory check. Visual check.	No fault	
	Resistor	Is there any damage to the resistor insulation? Is the wiring in the resistor damaged (open)?		O		Visual check. Disconnect one of the connections and measure with a tester.	No fault Error must be within ±10% the displayed resistance	Digital Multi-Meter/Analog Tester
Control Circuit Protective Circuit	Operation Check	Is there any unbalance between each phases of the output voltage? Nothing must be wrong with display circuit after executing the sequence protective operation		O	O	Measure the voltage between the output terminals U, V and W. Short and open the inverter protective circuit output.	The voltage balance between the phases for 200V (800V) class is under 4V (8V). The fault circuit operates according to the sequence.	Digital Multi-Meter/Rectifying Voltmeter
Cooling System	Cooling Fan	Is there any abnormal oscillation or noise? Is the connection area loose?	O	O		Turn OFF the power and turn the fan by hand. Tighten the connections.	Must rotate smoothly. No fault	
Display	Meter	Is the displayed value correct?	O	O		Check the meter reading at the exterior of the panel	Check the specified and management values.	Voltmeter/ Ammeter etc.
Motor	All	Are there any abnormal vibrations or noise? Is there any unusual odor?	O	O		Auditory, sensory, visual check. Check for overheat and damage.	No fault	
	Insulation Resistor	Megger check (between the output terminals and the ground terminal)			O	Undo the U, V and W connections and tie the motor wiring.	Over 5MΩ	500V class Megger

Note: Values in () is for the 400V class inverters.

APPENDIX A - FUNCTIONS BASED ON USE

Set the function properly according to the load and operating conditions. Application and related functions are listed in the following table.

Use	Related Parameter Code
Accel/Decel Time, Pattern Adjustment	DRV-01 [Acceleration Time], DRV-02 [Deceleration Time], FUN 11 [Acceleration Pattern], FUN 12 [Deceleration Pattern]
Reverse Rotation Prevention	FUN 03 [Forward, Reverse Prevention]
Minimum Accel/Decel Time	FUN 11 [Acceleration Pattern], FUN 12 [Deceleration Pattern]
Accel/Decel at Continuous Rating Range	FUN 11 [Acceleration Pattern], FUN 12 [Deceleration Pattern]
Braking Operation Adjustment	FUN 15 [Stop Method], FUN 33~36 [DC Braking],
Operations for Frequencies Over 60 Hz	FUN 04 [Maximum Frequency], FUN 25~26 [Frequency Limit]
Selecting an Appropriate Output Characteristics for the Load	FUN 03 [Maximum Frequency], FUN 05 [Base Frequency]
Motor Output Torque Adjustment	FUN 05 [Starting Frequency], FUN 09~10 [Torque Boost], FUN 45~46 [Stall Prevention], FUN 39~40 [Rated Motor]
Output Frequency Limit	FUN 25~27 [Frequency Upper/Lower Limit], I/O 20~24 [Analog Frequency Setting]
Motor Overheat Protection	FUN 51~53 [Electronic Thermal], FUN 38~40 [Rated Motor]
Multi Step Operation	I/O 01~06 [Define the Multi Function Input Terminals], I/O 12~19 [Jog, Multi Step Frequency], FUN 25~27 [Frequency Upper/Lower Limit]
Jog Operation	I/O 12 [Jog Frequency]
Frequency Jump Operation	FUN 28~32 [Frequency Jump]
Timing the Electronic Brake Operation	I/O 39~40 [Frequency Detection Level], I/O 07~11 [Multi Function Output]
Displaying the Rotating Speed	DRV 04 [Motor Speed], FUN 41~42 [Motor RPM Display Gain]
Function Alteration Prevention	FUN 98 [Parameter Lock]
Energy Saving	FUN 14 [Energy Saving]
Auto Restart Operation After Alarm Stop	FUN 42~43 [Auto Retry]
PID Feedback Operation	FUN 62~72 [PID Operation]
Frequency Reference Signal and Output Adjusting	FUN 20~24 [Analog Frequency Setting]
Define the Multi-Function Input Terminals	I/O 01~06 [Define the Multi-Function Input Terminals]
Define the Multi-Function Input Terminals	I/O 07~11 [Multi Function Auxiliary Contact Output Setting]
Commercial Line <input type="checkbox"/> inverter Switchover Operation	I/O 01~06 [Define the Multi-Function Input Terminals], I/O 07~11 [Multi-Function Auxiliary Contact Output Setting]
Frequency Meter Calibration	I/O 34~37 [FM Output]
Operate by Communicating with a Computer	I/O 50 [Inverter No.], I/O 51 [communication Speed], I/O 52 [communication Timeout]

APPENDIX B - PARAMETERS BASED ON APPLICATION

Application	Parameter Code
DRV Group	
When you want to change the frequency setting	DRV 00
When you want to change the acceleration and deceleration time of the motor	DRV 01, DRV 02
FUN Group	
When you want to use the Jump Code	FUN 00
When you want to change the run/stop method	FUN 02
When you want to change the frequency reference source	FUN 01
When you want to prevent the motor from rotating at opposite directions	FUN 03
When you want to change the stopping method	FUN15
When DC injection braking is required before starting	FUN 33~36
When you want to set the maximum frequency and the base frequency according to the rated torque of the motor	FUN 37~40
When you want to adjust the starting frequency	FUN 06
When a large starting torque is needed for loads such as elevators (Manual/Auto Torque Boost)	FUN 09~10
When you want to select an appropriate output characteristic (V/F characteristic) according to loads	FUN 08
When you want to set up your own V/F pattern	FUN 16~19
When you want to use the energy saving function	FUN 14
When you want to protect the motor from overheating	FUN 51~54
When you want to output a signal when the overload condition lasts more than a fixed amount of time	FUN 47~48
When you want to cut off the output when the overload condition lasts more than a fixed amount of time	FUN 49~50
When you want to set the stall prevention function	FUN 45~46
When you want to prevent the resonance from the oscillating characteristics of a machine	FUN 28~31
When you want to start the inverter as soon as the power is turned ON	FUN 55
When you want to restart the inverter by resetting the fault when a fault occur	FUN 42~43
When you want to use the instant power failure restart function (Speed Search)	FUN 56~58
When you want to enter the motor constants	FUN 38~40
When you want to reduce noise or leakage current by changing the PWM carrier frequency	FUN 61
When you want to operate using PID feedback	FUN 62~72
When you want to copy the inverter parameter to another inverter	FUN 95~96
When you want to initialize the parameters	FUN 97
When you want to prevent the parameters from being changed	FUN 98
I/O Group	
When you want to set the analog voltage or current for the frequency reference	I/O 34~37
When you want to set the step frequency	I/O 13~19
When you want to change the functions for the input terminals P1~P6	I/O 12 ~ 14
When you want to check the status of the input/output terminals	I/O 43~44
When you want to check the fault history of the inverter	I/O 46~47
When you want to use the JOG and multi step speed operation	I/O 01~06
When you want to change the 1 st ~ 7 th acceleration/deceleration time	I/O 20~23
When you want to set the frequency detection level	I/O 39~40
When you want to change the functions of the multi function auxiliary contact output (AXA-AXC)	I/O 07~11
When you want to exchange the motor to commercial power line from inverter or the opposite	I/O 01~06

