



Series 15J Inverter Control

Installation and Operating Manual

Table of Contents

Section 1	
Quick Start	1-1
Overview	1-1
Quick Start Checklist	1-1
Power-up Procedure	1-2
Section 2	
General Information	2-1
CE Compliance	2-1
Overview	2-1
Limited Warranty	2-1
Safety Notice	2-2
Section 3	
Receiving and Installation	3-1
Receiving & Inspection	3-1
Physical Installation	3-1
Control Installation	3-1
Optional Remote Keypad Installation	3-2
Electrical Installation	3-3
System Grounding	3-3
Line Impedance	3-4
Line Reactors	3-4
Load Reactors	3-4
Input Current Requirements	3-6
Cover Removal	3-6
Terminal Identification	3-7
AC Line Connections	3-7
Reduced Input Voltage Derating	3-7
Power Disconnect	3-7
Protective Devices	3-8
Three Phase Wire Size and Protection Devices	3-8
3 Phase Installation	3-9
115VAC 1 Phase Wire Size and Protection Devices	3-10
230VAC Single Phase Derating for Three Phase Controls	3-11
Motor Brake Connections	3-12
Optional Dynamic Brake Hardware	3-12
Inputs and Outputs	3-13
Analog Inputs	3-13
Analog Output	3-14
Relay Outputs	3-14
External Trip Input	3-14

Selection of Operating Mode	3-15
Keypad Connection	3-15
Standard Run 3 Wire Connection	3-17
7 Speed Connection	3-18
Fan Pump 2 Wire Connection	3-19
Fan Pump 3 Wire Connection	3-20
Process Control Connection	3-21
3 Speed Analog 2 Wire Connection	3-22
3 Speed Analog 3 Wire Connection	3-23
EPOT 2 Wire Connection	3-24
EPOT 3 Wire Connection	3-25
Pre-Operation Checklist	3-26
Power-up Procedure	3-26
Section 4	
Programming and Operation	4-1
Overview	4-1
Operation Examples	4-3
Operating the Control from the Keypad	4-3
Accessing the Keypad JOG Command	4-3
Speed Adjustment using Local Speed Reference	4-4
Speed Adjustment using Arrow Keys	4-4
Display Mode	4-5
Adjusting Display Contrast	4-5
Display Screens	4-6
Fault Log Access	4-6
Diagnostic Information Access	4-7
Program Mode	4-8
Parameter Blocks Access for Programming	4-8
Changing Parameter Values	4-9
Reset Parameters to Factory Settings	4-10
Parameter Definitions	4-11
Parameter Block Definitions	4-13
Section 5	
Troubleshooting	5-1
No Keypad Display - Display Contrast Adjustment	5-1
Wrong Language Selection	5-2
Diagnostic Information Access	5-3
How to Access the Fault Log	5-4
How to Clear the Fault Log	5-4
Electrical Noise Considerations	5-9
Relay and Contactor Coils	5-9
Wires between Controls and Motors	5-9
Special Drive Situations	5-10
Special Motor Considerations	5-10
Analog Signal Wires	5-10

Section 6	
Specifications and Product Data	6-1
Specifications:	6-1
Operating Conditions:	6-1
Keypad Display:	6-2
Control Specifications:	6-2
Analog Inputs:	6-3
Analog Output:	6-3
Digital Inputs:	6-3
Digital Outputs:	6-3
Fault Indications:	6-3
Ratings	6-4
Terminal Tightening Torque Specifications	6-4
Mounting Dimensions	6-5
Appendix A	
Dynamic Brake Hardware	A-1
Appendix B	
Parameter Values	B-1
Appendix C	
Remote Keypad Mounting Template	C-1

Section 1

Quick Start

Overview

If you are an experienced user of Baldor controls, you are probably already familiar with the keypad programming and keypad operation methods. If so, this quick start guide has been prepared for you. This procedure will help get your system up and running in the keypad mode quickly and will allow motor and control operation to be verified. It assumes that the Control and Motor are correctly installed (see Section 3 for procedures) and that you have an understanding of the keypad programming & operation. It is not necessary to wire the terminal strip to operate in the Keypad mode (Section 3 describes how to wire the terminal strip).

The quick start procedure is as follows:

1. Read the Safety Notice and Precautions in section 2 of this manual.
2. Mount the control. Refer to Section 3, "Physical Installation" procedure.
3. Connect AC power. Refer to Section 3, "AC Line Connections".
4. Connect the motor. Refer to Section 3, "AC Line Connections".

Quick Start Checklist Check of electrical items.

1. Verify that the AC line voltage at the source matches the control rating.
2. Inspect all power connections for accuracy, workmanship and tightness as well as compliance to codes.
3. Verify that the control and motor are grounded to each other and the control is connected to earth ground.
4. Check all signal wiring for accuracy.
5. Be certain all brake coils, contactors and relay coils have noise suppression. This should be an R-C filter for AC coils and reverse polarity diodes for DC coils. MOV type transient suppression is not adequate.

Check of Motors and Couplings

1. Verify freedom of motion of motor shaft.
2. Verify that all motor couplings are tight without backlash.
3. If holding brakes are used, verify they are properly adjusted to fully release and set to the desired torque value.

⚠ WARNING: Make sure that unexpected operation of the motor shaft during start up will not cause injury to personnel or damage to equipment.

Power-up Procedure

1. Turn power on. Be sure no faults are displayed on the keypad display.
2. Set the Level 1 Input block, Operating Mode to “Keypad”.
3. Set the Level 2 Output Limits block, “MIN Output FREQ” parameter.
4. Set the Level 2 Output Limits block, “MAX Output FREQ” parameter.
5. If the desired peak current limit setting is not correct, set the Level 2 Output Limits block, “PK Current Limit” parameter as desired.
6. Enter the following motor data in the Level 2 Motor Data block parameters:
 - Motor Rated Amps (FLA)
 - Motor Rated Speed (base speed)
 - Motor Rated Frequency (Nameplate)
7. If External Dynamic Brake hardware is used, set the Level 2 Brake Adjust block parameters as desired.
8. Set the Level 1 V/HZ Boost block, “V/HZ Profile” parameter for the correct V/Hz ratio for your application.
9. If the load is a high initial starting torque type, the torque boost and accel time may need to be increased. Set the Level 1 V/HZ Boost block, “Torque Boost” and the Level 1 Accel/Decel Rate block, “Accel Time #1” as required.
10. Select and program additional parameters to suit your application.

The control is now ready for use in keypad mode. The terminal strip wiring may be changed and different parameter values used for another operating mode.

Section 2

General Information

CE Compliance

A custom unit may be required, contact Baldor. Compliance to Directive 89/336/EEC is the responsibility of the system integrator. A control, motor and all system components must have proper shielding grounding and filtering as described in MN1383. Please refer to MN1383 for installation techniques for CE compliance.

Overview

The Baldor Series 15J control is a PWM inverter motor control. The control operates by converting AC line power into fixed DC power. The DC power is then pulse width modulated into synthesized three-phase AC line voltage for the motor. In this way, the control converts the fixed input frequency to variable output frequency to cause the motor to have variable speed operation.

The rated horsepower of the control is based on a NEMA design B four pole motor and 60Hz operation at nominal rated input voltage. If any other type of motor is used, or input voltage other than 230 or 460 VAC is applied to the input terminals, the control should be sized to the motor using the rated output current of the control.

The Baldor Series 15J control may be used in many different applications. It can be programmed to operate in a number of operating modes, PWM rates and output current levels for custom operation.

It is the responsibility of the user to determine the optimum operating mode for the application. These choices are programmed using the keypad as explained in the programming section of this manual.

Limited Warranty

For a period of two (2) years from the date of original purchase, BALDOR will repair or replace without charge controls and accessories which our examination proves to be defective in material or workmanship. This warranty is valid if the unit has not been tampered with by unauthorized persons, misused, abused, or improperly installed and has been used in accordance with the instructions and/or ratings supplied. This warranty is in lieu of any other warranty or guarantee expressed or implied. BALDOR shall not be held responsible for any expense (including installation and removal), inconvenience, or consequential damage, including injury to any person or property caused by items of our manufacture or sale. (Some states do not allow exclusion or limitation of incidental or consequential damages, so the above exclusion may not apply.) In any event, BALDOR's total liability, under all circumstances, shall not exceed the full purchase price of the control. Claims for purchase price refunds, repairs, or replacements must be referred to BALDOR with all pertinent data as to the defect, the date purchased, the task performed by the control, and the problem encountered. No liability is assumed for expendable items such as fuses.

Goods may be returned only with written notification including a BALDOR Return Authorization Number and any return shipments must be prepaid.

Safety Notice:

This equipment contains voltages that may be as great as 1000 volts! Electrical shock can cause serious or fatal injury. Only qualified personnel should attempt the start-up procedure or troubleshoot this equipment.

This equipment may be connected to other machines that have rotating parts or parts that are driven by this equipment. Improper use can cause serious or fatal injury. Only qualified personnel should attempt the start-up procedure or troubleshoot this equipment.

PRECAUTIONS:

- ⚠ WARNING:** Do not touch any circuit board, power device or electrical connection before you first ensure that power has been disconnected and there is no high voltage present from this equipment or other equipment to which it is connected. Electrical shock can cause serious or fatal injury. Only qualified personnel should attempt the start-up procedure or troubleshoot this equipment.
- ⚠ WARNING:** Be sure that you are completely familiar with the safe operation of this equipment. This equipment may be connected to other machines that have rotating parts or parts that are controlled by this equipment. Improper use can cause serious or fatal injury. Only qualified personnel should attempt the start-up procedure or troubleshoot this equipment.
- ⚠ WARNING:** Do not use motor overload relays with an automatic reset feature. These are dangerous since the process may injure someone if a sudden or unexpected automatic restart occurs. If manual reset relays are not available, disable the automatic restart feature using external control wiring.
- ⚠ WARNING:** This unit has an automatic restart feature that will start the motor whenever input power is applied and a RUN (FWD or REV) command is issued and maintained. If an automatic restart of the motor could cause injury to personnel, the automatic restart feature should be disabled by changing the “Restart Auto/Man” parameter to MANUAL.
- ⚠ WARNING:** Be sure the system is properly grounded before applying power. Do not apply AC power before you ensure that grounds are connected. Electrical shock can cause serious or fatal injury.
- ⚠ WARNING:** Do not remove cover for at least five (5) minutes after AC power is disconnected to allow capacitors to discharge. Electrical shock can cause serious or fatal injury.
- ⚠ WARNING:** Improper operation of control may cause violent motion of the motor shaft and driven equipment. Be certain that unexpected motor shaft movement will not cause injury to personnel or damage to equipment. Peak torque of several times the rated motor torque can occur during control failure.

Continued on next page.

-
- ⚠ WARNING:** Motor circuit may have high voltage present whenever AC power is applied, even when motor is not rotating. Electrical shock can cause serious or fatal injury.
 - ⚠ WARNING:** Dynamic brake resistors may generate enough heat to ignite combustible materials. Keep all combustible materials and flammable vapors away from brake resistors.
 - ⚠ Caution:** Suitable for use on a circuit capable of delivering not more than 5,000 RMS symmetrical amperes, at rated voltage.
 - ⚠ Caution:** Do not supply any power on the External Trip (motor thermostat) leads at J4-17 or J4-18 as the control may be damaged. Use a dry contact type that requires no external power to operate.
 - ⚠ Caution:** Disconnect motor leads (T1, T2 and T3) from control before you perform a “Megger” test on the motor. Failure to disconnect motor from the control will result in extensive damage to the control. The control is tested at the factory for high voltage / leakage resistance as part of Underwriters Laboratories Inc. requirements.
 - ⚠ Caution:** Do not connect AC power to the motor terminals T1, T2 and T3. Connecting AC power to these terminals may result in damage to the control.
 - ⚠ Caution:** Baldor recommends not using “Grounded Leg Delta” transformer power leads that may create ground loops. Instead, we recommend using a four wire Wye.

Section 3

Receiving and Installation

Receiving & Inspection

The Series 15J Inverter Control is thoroughly tested at the factory and carefully packaged for shipment. When you receive your control, there are several things you should do immediately:

1. Observe the condition of the shipping container and report any damage immediately to the commercial carrier that delivered your control.
2. Verify that the control you received is the same as listed on your purchase order.
3. If the control is to be stored for several weeks before use, be sure that it is stored in a location that conforms to published storage specifications. (Refer to Section 6 of this manual).

Physical Installation

The mounting location of the 15J is important. It should be installed in an area that is protected from direct sunlight, corrosives, harmful gases or liquids, dust, metallic particles, and vibration. Exposure to these elements can reduce the operating life and degrade performance of the control.

Several other factors should be carefully evaluated when selecting a location for installation:

1. For effective cooling and maintenance, the control should be mounted on a smooth, non-flammable vertical surface. Table 3-1 lists the Watts Loss ratings for enclosure sizing.
2. At least two inches clearance must be provided on all sides for airflow.
3. Front access must be provided to allow the control cover to be opened or removed for service and to allow viewing of the Keypad Display.
4. **Altitude derating.** Up to 3300 feet (1000 meters), no derating required. Above 3300 feet, derate output current by 2% for each 1000 feet above 3300 feet.
5. **Temperature derating.** Up to 40°C, no derating required. Above 40°C, derate output current by 2% per °C above 40°C. Maximum ambient is 55°C.

Table 3-1 Series 15J Watts Loss Ratings

115VAC		230VAC		460VAC	
2.5kHz PWM	7.5kHz PWM	2.5kHz PWM	7.5kHz PWM	2.5kHz PWM	7.5kHz PWM
17 Watts/ Amp	20 Watts/ Amp	17 Watts/ Amp	20 Watts/ Amp	19 Watts/ Amp	28 Watts/ Amp

Control Installation

The control must be securely fastened to the mounting surface. Use the four (4) mounting holes to fasten the control to the mounting surface or enclosure.

Shock Mounting

If the control will be subjected to levels of shock greater than 1G or vibration greater than 0.5G at 10 to 60Hz, the control should be shock mounted.

Excessive vibration within the control could cause internal connections to loosen and cause component failure or electrical shock hazard.

Optional Remote Keypad Installation

Note: Requires phone jack connector on the control board. Some models may not have a phone jack installed. If the phone jack is not installed and you wish to connect a remote keypad, contact Baldor.

A separate keypad may be remotely mounted using an optional Baldor keypad extension cable (in addition to the keypad within the control). Keypad assembly (CBLSM015KP - 5 ft, CBLSM046KP - 15 ft or CBLSM091KP - 30 ft) comes complete with the extension cable and gasket required to mount it to an enclosure. When the keypad is properly mounted to a NEMA Type 4X indoor enclosure, it retains the Type 4X indoor rating.

Tools Required:

- Center punch, tap handle, screwdrivers (Phillips and straight) and crescent wrench.
- 8-32 tap and #29 drill bit (for tapped mounting holes) or #19 drill (for clearance mounting holes).
- 1-¹/₄" standard knockout punch (1-¹¹/₁₆" nominal diameter).
- RTV sealant.
- (4) 8-32 nuts and lock washers.
- Extended 8-32 screws (socket fillister) are required if the mounting surface is thicker than 12 gauge and is not tapped (clearance mounting holes).
- Remote keypad mounting template. A tear out copy is provided at the end of this manual for your convenience. (Photo copy or tear out.)

Mounting Instruction: For tapped mounting holes

1. Locate a flat 4" wide x 5.5" minimum height mounting surface. Material should have sufficient thickness (14 gauge minimum).
2. Place the template on the mounting surface or mark the holes as shown.
3. Accurately center punch the 4 mounting holes (marked A) and the large knockout (marked B).
4. Drill four #29 mounting holes (A). Thread each hole using an 8-32 tap.
5. Locate the 1-¹/₄" knockout center (B) and punch using the manufacturers instructions.
6. Debur knockout and mounting holes making sure the panel stays clean and flat.
7. Apply RTV to the 4 holes marked (A).
8. Assemble the keypad to the panel. Use 8-32 screws, nuts and lock washers.
9. From the inside of the panel, apply RTV over each of the four mounting screws and nuts. Cover a ³/₄" area around each screw while making sure to completely encapsulate the nut and washer.

Mounting Instructions: For clearance mounting holes

1. Locate a flat 4" wide x 5.5" minimum high mounting surface. Material should have sufficient thickness (14 gauge minimum).
2. Place the template on the mounting surface or mark the holes as shown on the template.
3. Accurately center punch the 4 mounting holes (marked A) and the large knockout (marked B).
4. Drill four #19 clearance holes (A).
5. Locate the 1-1/4" knockout center (B) and punch using the manufacturers instructions.
6. Debur knockout and mounting holes making sure the panel stays clean and flat.
7. Apply RTV to the 4 holes marked (A).
8. Assemble the keypad to the panel. Use 8-32 screws, nuts and lock washers.
9. From the inside of the panel, apply RTV over each of the four mounting screws and nuts. Cover a 3/4" area around each screw while making sure to completely encapsulate the nut and washer.

Electrical Installation

Interconnection wiring is required between the motor control, AC power source, motor, host control and any operator interface stations. Use listed closed loop connectors that are of appropriate size for the wire gauge being used. Connectors are to be installed using crimp tool specified by the manufacturer of the connector. Only Class 1 wiring should be used.

System Grounding

Baldor Controls are designed to be powered from standard three phase lines that are electrically symmetrical with respect to ground. System grounding is an important step in the overall installation to prevent problems. The recommended grounding method is shown in Figure 3-1.

Ungrounded Distribution System

With an ungrounded power distribution system it is possible to have a continuous current path to ground through the MOV devices. To avoid equipment damage, an isolation transformer with a grounded secondary is recommended. This provides three phase AC power that is symmetrical with respect to ground.

Input Power Conditioning

Baldor controls are designed for direct connection to standard three phase lines that are electrically symmetrical with respect to ground. Certain power line conditions must be avoided. An AC line reactor or an isolation transformer may be required for some power conditions.

- If the feeder or branch circuit that provides power to the control has permanently connected power factor correction capacitors, an input AC line reactor or an isolation transformer should be connected between the power factor correction capacitors and the control.

- If the feeder or branch circuit that provides power to the control has power factor correction capacitors that are switched on line and off line, the capacitors must not be switched while the control is connected to the AC power line. If the capacitors are switched on line while the control is still connected to the AC power line, additional protection is required. TVSS (Transient Voltage Surge Suppressor) of the proper rating should be installed between the AC line reactor or an isolation transformer and the AC input to the control.

Line Impedance

The Baldor Series 15J control requires a minimum line impedance of 1%. The input impedance of the power lines can be determined as follows:

Measure the line to line voltage at no load and at full rated load. Use these measured values to calculate impedance as follows:

$$\% \text{Impedance} = \frac{(\text{Volts}_{\text{NoLoad}} - \text{Volts}_{\text{FullLoad}})}{(\text{Volts}_{\text{NoLoad}})} \times 100$$

Line Reactors

3 phase line reactors are available from Baldor. The size of the line reactor to use is based on the maximum continuous load. If providing your own line reactor, use the following formula to calculate the minimum inductance required. Table 3-3 lists the input current required for this calculation.

$$L = \frac{(V_{L-L} \times 0.01)}{(I \times \sqrt{3} \times 377)}$$

Where: L Minimum inductance in henrys.
 V_{L-L} Input volts measured line to line.
 0.01 Desired percentage of input impedance (1% shown).
 I Input current rating of control.
 377 Constant used with 60Hz power.
 Use 314 with 50Hz power.

Table 3-2 Recommended Line Reactors

230VAC, 60Hz, 3% Impedance				460VAC, 60Hz, 3% Impedance			
Catalog No.	HP	Amps	Inductance (mH)	Catalog No.	HP	Amps	Inductance (mH)
LRAC00401	1	4	3	LRAC00202	1	2	12
LRAC00801	1.5	8	1.15	LRAC00202	1.5	2	12
LRAC00801	2	8	1.15	LRAC00402	2	4	6.5
LRAC01201	3	12	1.25	LRAC00402	3	4	6.5
LRAC01801	5	18	0.8	LRAC00802	5	8	3.0
LRAC3501	7.5	25	0.5	LRAC01202	7.5	12	2.5
				LRAC01802	10	18	1.5

Load Reactors

Line reactors may be used at the control output to the motor. When used this way, they are called Load Reactors. Load Reactors serve several functions.

- Protect the control from a short circuit at the motor.
- Limit the rate of rise of motor surge currents.
- Slow the rate of change of power the control delivers to the motor.

Load reactors should be installed as close to the control as possible.

Figure 3-1 Recommended System Grounding

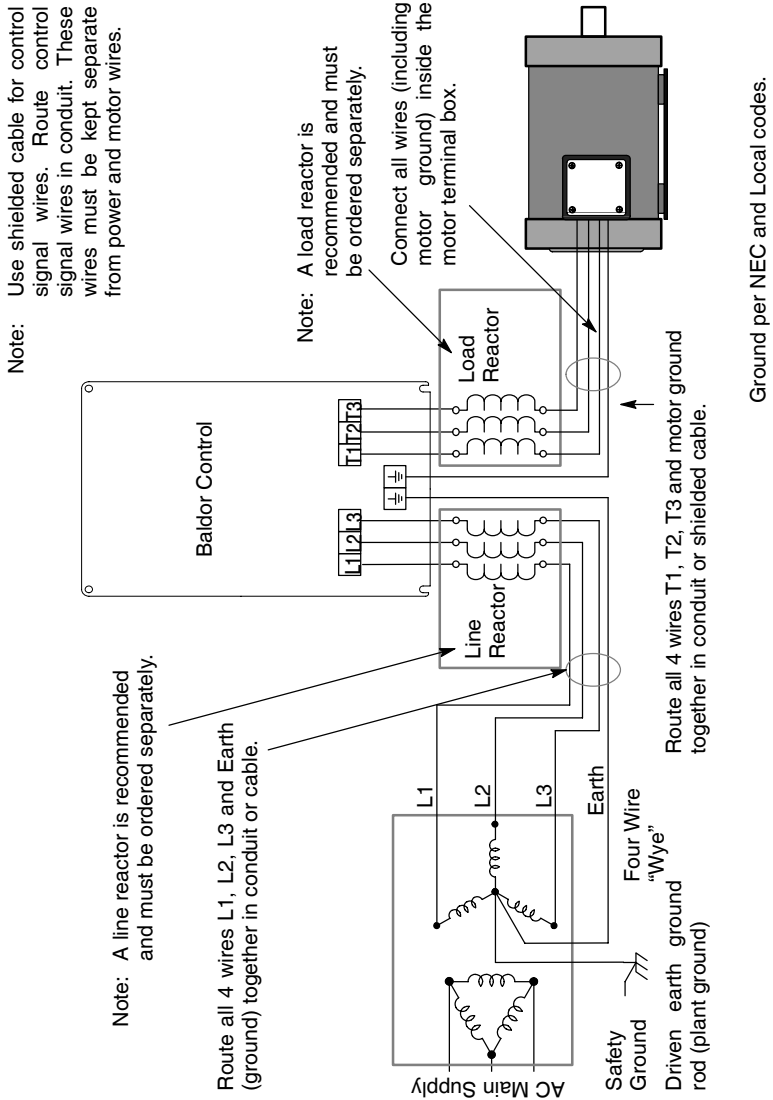

Input Current Requirements

Table 3-3 Input Current Requirements for Stock Products

115VAC - 1 ϕ		230VAC - 3 ϕ		460VAC - 3 ϕ	
Catalog Numbers	Input Amps	Catalog Numbers	Input Amps	Catalog Numbers	Input Amps
ID15J1F33-ER	3.5	ID15J201-ER	5.0	ID15J401-ER	2.5
ID15J1F50-ER	5.0	ID15J201F5-ER	7.0	ID15J401F5-ER	3.5
ID15J1F75-ER	7.5	ID15J202-ER	8.0	ID15J402-ER	4.0
ID15J101-ER	10.0	ID15J203-ER	11.0	ID15J403-ER	5.5
		ID15J205-ER	15.0	ID15J405-ER	9.0
				ID15J407-ER	10.0
				ID15J410V-ER	13.0

Cover Removal

The cover is made of plastic and could be damaged during removal if handled roughly. Refer to Figure 3-2. Insert a screwdriver or small blade tool and pry cover outward as shown to release the side.

When both sides are released, remove the cover.

Figure 3-2 Cover Removal

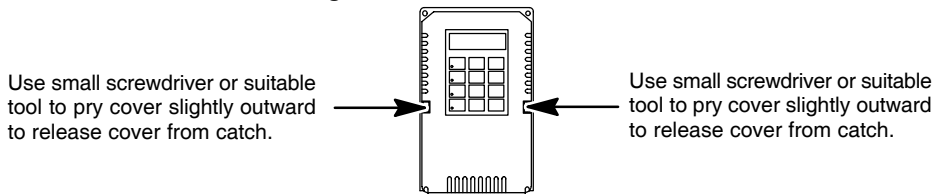

Terminal Identification

The terminals for signal, AC power and motor connections are shown in Figure 3-3. Separate ground connections are provided for power and motor grounds.

Figure 3-3 Terminal Identification

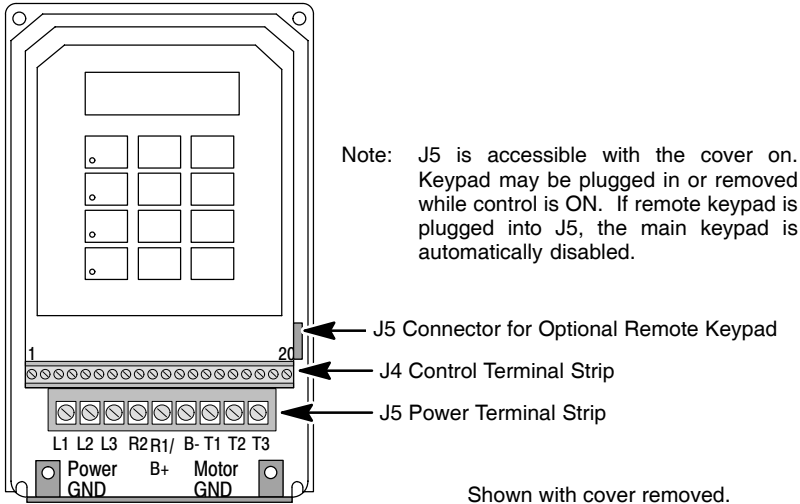

AC Line Connections

Be sure all power to the control is disconnected before proceeding. If power has been applied to the control, wait at least 5 minutes after power disconnect for residual voltage across the bus capacitors to discharge.

Reduced Input Voltage Derating

All power ratings stated in Section 6 are for the nominal AC input voltages (115, 230, or 460). The power rating of the control must be reduced when operating at a reduced input voltage. The amount of reduction is the ratio of the voltage change.

Examples:

A 5hp, 230VAC control operating at 208VAC has a reduced power rating of 4.52hp.

$$5\text{HP} \times \frac{208\text{VAC}}{230\text{VAC}} = 4.52\text{hp}$$

Likewise, a 5hp, 460VAC control operating at 380VAC has a reduced power rating of 4.13hp.

$$5\text{HP} \times \frac{380\text{VAC}}{460\text{VAC}} = 4.13\text{hp}$$

Power Disconnect

A power disconnect should be installed between the input power service and the control for a fail-safe method to disconnect power. The control will remain in a powered-up condition until all input power is removed from the control and the internal bus voltage is discharged.

Protective Devices

Recommended fuse sizes are based on the following:
 115% of maximum continuous current for time delay.
 150% of maximum continuous current for Fast or Very Fast action.

Note: These general size recommendations do not consider harmonic currents or ambient temperatures greater than 40°C.

Be sure a suitable input power protection device is installed. Use the recommended fuses listed in Tables 3-4 and 3-5. Input and output wire size is based on the use of copper conductor wire rated at 75°C. The table is specified for NEMA B motors.

Fast Action Fuses: 230VAC, Buss KTN
 460VAC, Buss KTS

Very Fast Action: 230VAC, Buss JJN
 460VAC, Buss JJS

Time Delay Fuses: 230VAC, Buss FRN
 460VAC, Buss FRS

Three Phase Wire Size and Protection Devices

Table 3-4 Three Phase Wire Size and Protection Devices 230VAC Controls

Control Power Output Rating	Input Fuse		Wire Gauge	
	Fast Acting	Time Delay	AWG	mm ²
1	6	5	14	2.08
1.5	8	7	14	2.08
2	12	9	14	2.08
3	15	12	14	2.08
5	25	20	12	3.31

Table 3-5 Three Phase Wire Size and Protection Devices 460VAC Controls

Control Power Output Rating	Input Fuse		Wire Gauge	
	Fast Acting	Time Delay	AWG	mm ²
1	3	2.5	14	2.08
1.5	4	3.5	14	2.08
2	5	4.5	14	2.08
3	8	6.3	14	2.08
5	12	10	14	2.08
7.5	17.5	15	14	2.08
10	20	17.5	12	3.31

Note: All wire sizes are based on 75°C copper wire, 1% line impedance. Higher temperature, smaller gauge wire may be used per NEC and local codes. Recommended fuses are based on 40°C ambient, maximum continuous control output current and no harmonic current.

3 Phase Installation

The AC power and motor connections are shown in Figure 3-4. The 15J control has electronic I²t motor overload protection. If motor overloads are desired, they should be sized according to the manufacturers specifications and installed between the motor and the T1, T2 and T3 terminals of the control. Refer to Figure 3-3 for terminal locations.

Figure 3-4 3 Phase AC Power and Motor Connections

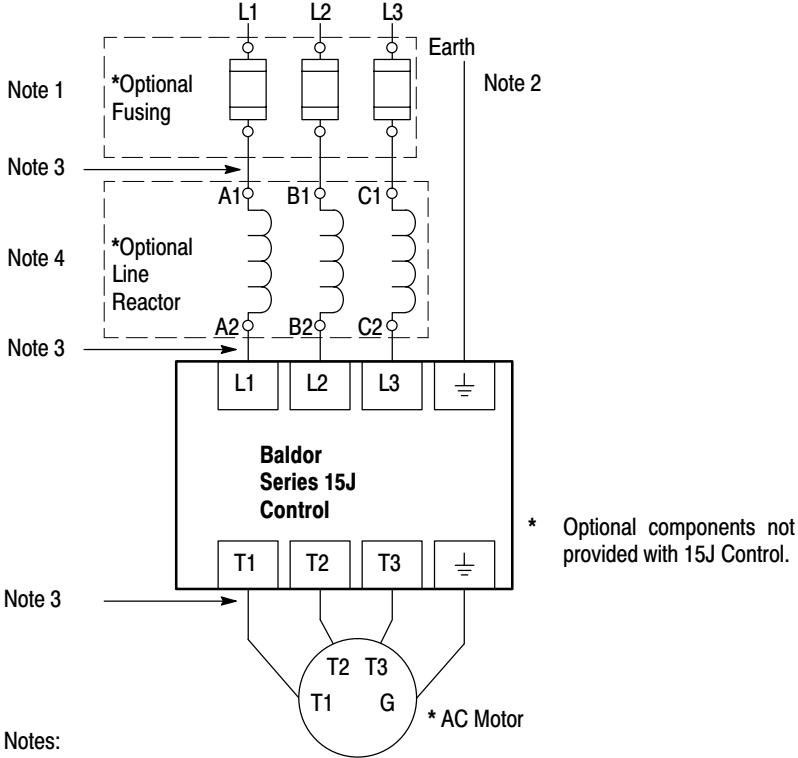

115VAC 1 Phase Wire Size and Protection Devices

Table 3-6 Wire Size and Protection Devices - 1 phase

Control Output Rating HP	Input Fuse		Wire Gauge	
	Fast Acting Amps	Time Delay Amps	AWG	mm ²
0.33	10	10	14	2.08
0.5	10	10	14	2.08
0.75	15	10	14	2.08
1.0	20	15	14	2.08

Note: All wire sizes are based on 75°C copper wire, 1% line impedance. Higher temperature, smaller gauge wire may be used per NEC and local codes. Recommended fuses are based on 40°C ambient, maximum continuous control output current and no harmonic current.

Figure 3-5 Single Phase AC Power and Motor Connections

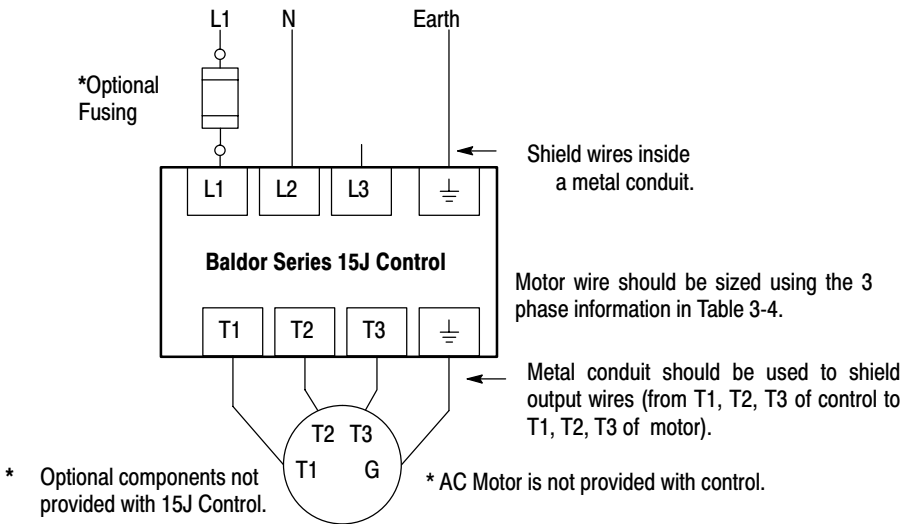

230VAC Single Phase Derating for Three Phase Controls

Single phase AC input power can be used to power a three phase control. However, the continuous and peak current ratings of the control must be reduced by 35% (derated).

Control Output Rating HP	Input Fuse		Wire Gauge	
	Fast Acting Amps	Time Delay Amps	AWG	mm ²
0.75	10	9	14	2.08
1	12	10	14	2.08
1.5	15	15	14	2.08
2	20	17.5	14	2.08
3	25	25	12	3.31

Note: All wire sizes are based on 75°C copper wire, 1% line impedance. Higher temperature, smaller gauge wire may be used per NEC and local codes. Recommended fuses are based on 40°C ambient, maximum continuous control output current and no harmonic current.

Figure 3-6 Single Phase 230VAC Power and Motor Connections

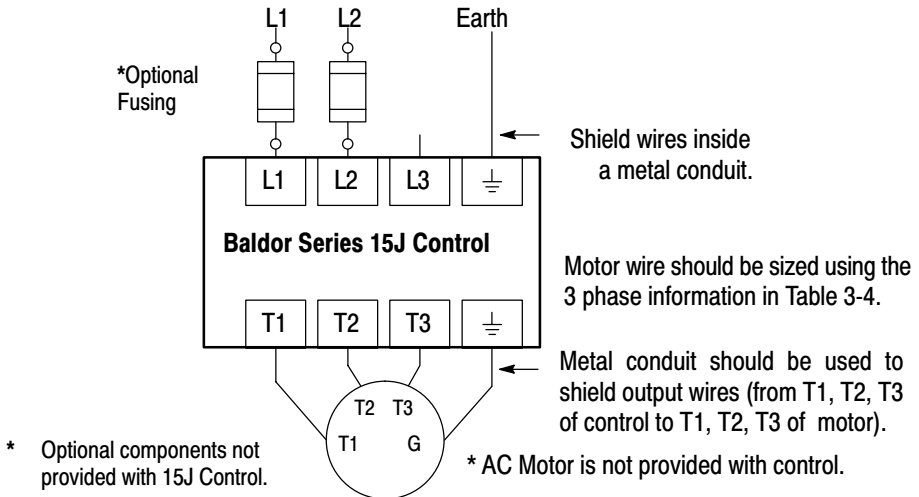

Motor Brake Connections

For motors with spring set brakes, connect the brake power leads and the motor power leads separately. Because the inverter has variable voltage output to the motor, the inverter may not supply enough power at low frequencies for proper brake operation. If using a motor with an internally connected brake, the brake power leads must be connected to a separate power source for proper brake operation.

Optional Dynamic Brake Hardware

Dynamic Brake (DB) Hardware must be installed on a flat, non-flammable, vertical surface for effective cooling and operation. See Figure 3-7 for terminal identification.

See Appendix A of this manual for additional information.

Note: Although not shown, metal conduit should be used to shield all power wires and motor leads.

Figure 3-7 Wiring for RGA Assembly

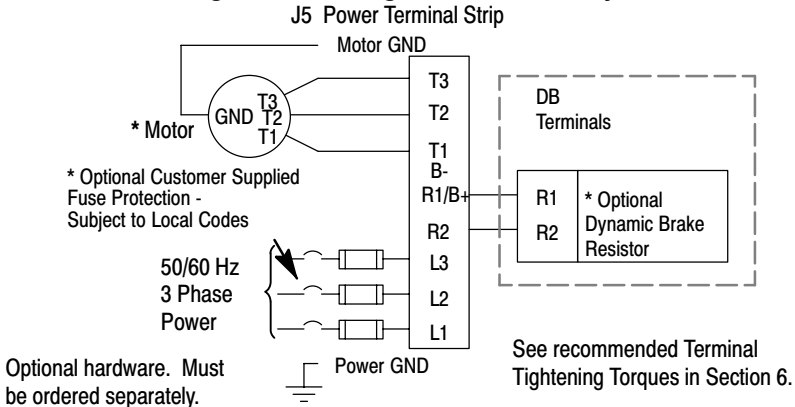

Inputs and Outputs (Refer to Figure 3-8).

Analog Inputs

Two analog inputs are available: analog input #1 (J4-5 and J4-4) and analog input #2 (J4-7 and J4-8) as shown. Either analog input #1 or #2 may be grounded provided the common mode range is not exceeded. Either analog input may be selected in the Level 1 INPUT block, ANA CMD Select parameter value. Analog input #1 is selected if parameter value "Potentiometer" is selected. Analog input #2 is selected if parameter value "0-10Volts, 0-5 Volts, 4-20mA or 0-20mA" is selected.

Figure 3-8 Analog Inputs and Outputs

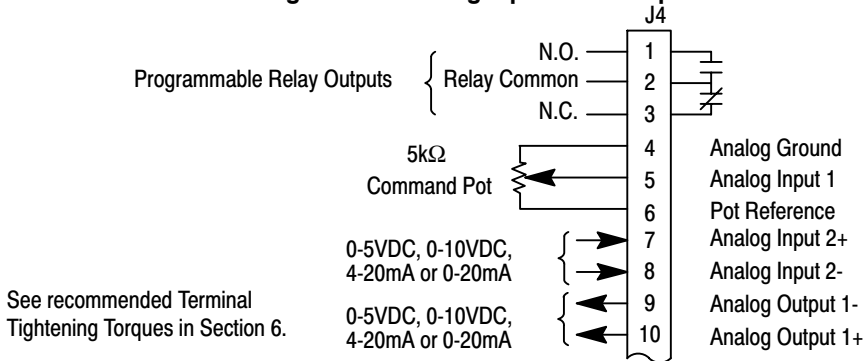

Analog Input #1

The single ended analog input #1 can be used when the controller is set to Standard Run, 7 Speed, Fan Pump 2 Wire, Fan Pump 3 Wire, Process Control, 3 SPD ANA 2Wire, 3 SPD ANA 3Wire, EPOT 2Wire or EPOT 3Wire (not Keypad).

The single ended analog input #1 can be used as a Speed command (Level 1 Input block, ANA CMD Select=Potentiometer).

Note: A potentiometer value of 5kΩ to 10kΩ, 0.5 watt may be used.

1. Connect the wires from the 5KΩ pot at the J4 terminal strip. One end of the pot is connected to J4-4 (analog ground) and the other end is connected to J4-6 (reference voltage).
2. Connect the wiper of the pot to J4-5. The voltage across terminals J4-4 and J4-5 is the speed command input.

Analog Input #2

Analog input #2 accepts a differential command 0-5VDC, 0-10VDC, 4-20 mA or 0-20 mA. The (Differential) command mode is defined in the Level 1 Input block ANA CMD Select parameter.

Note: Analog Input #2 can be used with Standard Run, 7 Speed, Fan Pump 2 Wire, Fan Pump 3 Wire, Process Control, 3 SPD ANA 2Wire or 3 SPD ANA 3Wire, EPOT 2Wire or EPOT 3Wire (not Keypad).

1. Connect the Analog Input + wire to J4-7 and the - wire to J4-8.
2. If using a 0-20 mA or 4-20 mA command signal, "Level 1 Input block, ANA CMD Select" parameter should be set to 0-20 mA or 4-20 mA.

Analog Output

One programmable analog output is provided at J4-10 and J4-9. The output is scaled 0 - 5 VDC, 0 - 10 VDC, 4-20mA or 0-20mA. The output function is programmed in the Level 1 Output block, Analog Out parameter value. The scaling of the output is programmed in the Level 1 Output block, Analog Scale.

Relay Outputs

One normally open (N.O.) and one normally closed (N.C.) relay contact is available at terminals J4-1, J4-2 and J4-3. J4-2 is relay common. The output is programmable in the Level 1 Output block, Relay Output parameter.

1. Connect the N.O. contact to another circuit by attaching the wires to J4-1 and J4-2.
2. Connect the N.C. contact to another circuit by attaching the wires to J4-3 and J4-2.

External Trip Input

Terminal J4-17 is available for connection to a normally closed thermostat or overload relay in some operating modes as shown in Figure 3-9. The thermostat or overload relay should be a dry contact type with no power available from the contact. If the motor thermostat or overload relay activates, the control will automatically shut down and give an external trip fault.

The optional relay (CR1) shown provides the isolation required. The N.O. contact is closed when power is applied to the relay and the motor is cold. Connect the external trip input wires to J4-17 and J4-18. Do not place these wires in the same conduit as the motor power leads.

To activate the external trip input, the external trip parameter in the Level 2 Protection Block must be set to "ON".

Figure 3-9 External Trip Input Connection

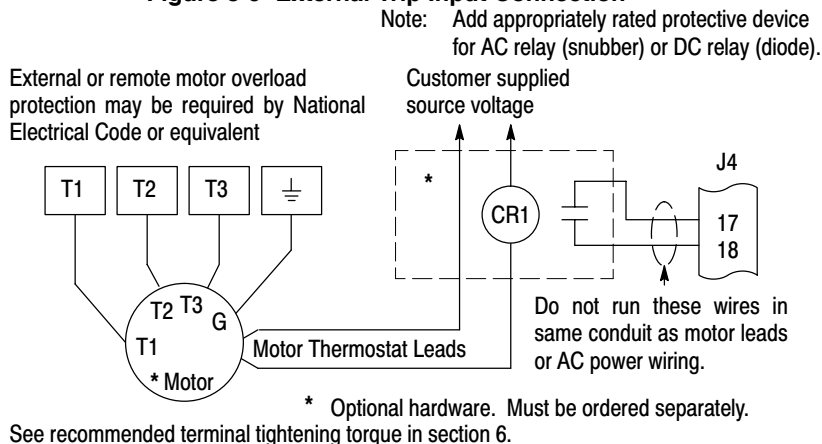

Selection of Operating Mode (and Connection Diagram)

Several operating modes are available that define the basic motor control setup and the operation of the input and output terminals. These operating modes are selected by programming the Operating Mode parameter in the Level 1 Input programming Block. Available operating modes include:

- Keypad
- Standard Run, 3 Wire
- 7 Speed
- Fan Pump 2 Wire
- Fan Pump 3 Wire
- Process Control
- 3 Speed Analog 2 Wire
- 3 Speed Analog 3 Wire
- Electronic Potentiometer 2 Wire
- Electronic Potentiometer 3 Wire

Each mode requires connections to the J4 terminal strip (except that all J4 connections are optional in the keypad mode).

Note: J4-19 and J4-20 are not to be used. These terminals are reserved for manufacturing use only.

Keypad Connection

The Keypad operating mode allows the control to be operated from the keypad. In this mode, no control connection wiring is required. However, the Stop, Accel/Decel select and External Trip inputs may optionally be used. All other digital inputs are inactive. The analog output and relay outputs remain active at all times.

For operation in Keypad mode, set the Level 1 Input block, Operating Mode parameter to Keypad.

To use the Stop input, J4-13 must be connected and the Level 1 Keypad Setup block, LOC. Hot Start parameter must be set to ON. The Stop line is normally closed. When opened, the motor will COAST or REGEN to a stop depending upon the setting of Level 1 Keypad Setup block Keypad Stop Key parameter value. Closing the input will immediately start the motor if a run command was given before the stop line was opened.

The Accel/Decel select input is used to select ACC / DEC / S-CURVE group 1 or group 2. This connection is made at J4-14.

The External Trip input is used to cause a fault condition during a motor over-temperature condition. The External Trip input (J4-17) must be connected and the External Trip parameter in the Level 2 Protection block must be set to ON. When J4-17 is opened, the motor will coast to a stop and an External Trip fault will be displayed on the keypad display.

Figure 3-10 Keypad Connection Diagram

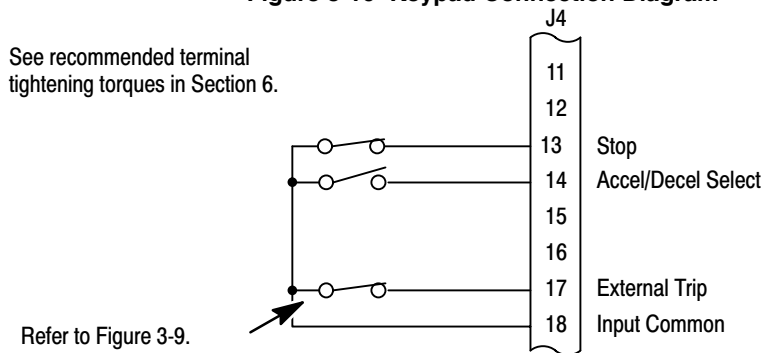

Keypad Only Connection

- J4-13** If J4-13 is connected, you must set Level 1 Keypad Setup block, LOC. Hot Start parameter to "ON" to activate the opto input. CLOSED allows normal control operation. OPEN disables the control and the motor will coast or brake to a stop. The motor will restart when J4-13 closes after open.
- J4-14** OPEN selects ACC / DEC / S-CURVE group 1. CLOSED selects group 2.
- J4-17** If J4-17 is connected, you must set Level 2 Protection block, External Trip to "ON" to activate the opto input. OPEN causes an external trip fault. The control will disable and the motor coasts to a stop. An external trip fault is displayed (also logged in the fault log). CLOSED allows normal operation.

Standard Run 3 Wire Connection

Figure 3-11 Standard Run 3-Wire Connection Diagram

See recommended terminal tightening torques in Section 6.

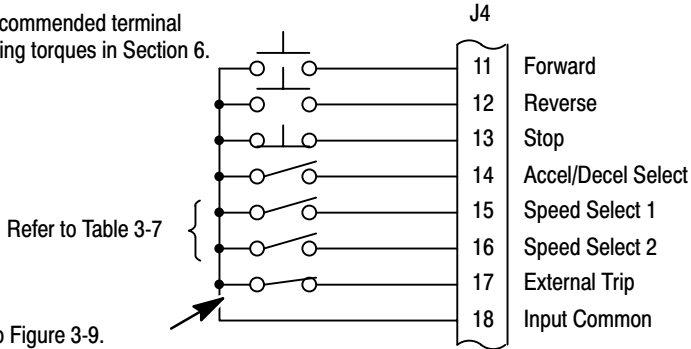

Table 3-7 Speed Select

Function	Speed Select 1	Speed Select 2
ANA CMD Select	Open	Open
Preset Speed 1	Closed	Open
Preset Speed 2	Closed	Closed
Preset Speed 3	Open	Closed

- J4-11 Momentary CLOSED starts Forward motor rotation.
- J4-12 Momentary CLOSED starts Reverse motor rotation.
- J4-13 Momentary OPEN motor decels to stop (depending on Keypad Stop mode).
- J4-14 OPEN selects ACC / DEC / S-CURVE group 1.
CLOSED selects group 2.
- J4-15 Selects preset speeds as defined in Table 3-7.
- J4-16 Selects preset speeds as defined in Table 3-7.
- J4-17 If J4-17 is connected, you must set Level 2 Protection block, External Trip to "ON" to activate the opto input.
OPEN causes an external trip fault. The control will disable and the motor coasts to a stop. An external trip fault is displayed (also logged in the fault log).
CLOSED allows normal operation.

7 Speed Connection

Figure 3-12 7 Speed Connection Diagram

See recommended terminal tightening torques in Section 6.

Refer to Table 3-8

Refer to Figure 3-9.

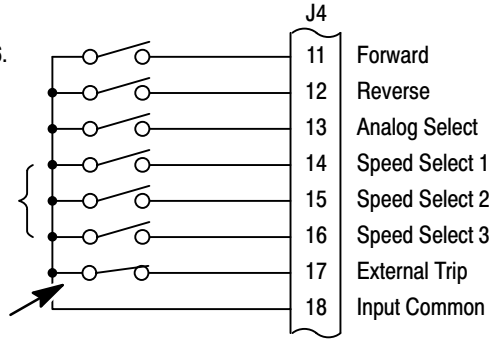

Table 3-8

Function	Speed Select 1	Speed Select 2	Speed Select 3
ANA CMD Select	Open	Open	Open
Preset Speed 1	Closed	Open	Open
Preset Speed 2	Closed	Closed	Open
Preset Speed 3	Closed	Closed	Closed
Preset Speed 4	Closed	Open	Closed
Preset Speed 5	Open	Open	Closed
Preset Speed 6	Open	Closed	Closed
Preset Speed 7	Open	Closed	Open

- J4-11 OPEN motor decels to stop (depending on Keypad Stop mode).
CLOSED starts Forward motor rotation.
- J4-12 OPEN motor decels to stop (depending on Keypad Stop mode).
CLOSED starts Reverse motor rotation.
- J4-13 OPEN selects setting of “ANA CMD Select” parameter.
CLOSED selects Analog Input #1.
- J4-14 Selects preset speeds as defined in Table 3-8.
- J4-15 Selects preset speeds as defined in Table 3-8.
- J4-16 Selects preset speeds as defined in Table 3-8.
- J4-17 If J4-17 is connected, you must set Level 2 Protection block, External Trip to “ON” to activate the opto input.
OPEN causes an external trip fault. The control will disable and the motor coasts to a stop. An external trip fault is displayed (also logged in the fault log).
CLOSED allows normal operation.

Fan Pump 2 Wire Connection

Figure 3-13 Fan/Pump 2 Wire Connection Diagram

See recommended terminal tightening torques in Section 6.

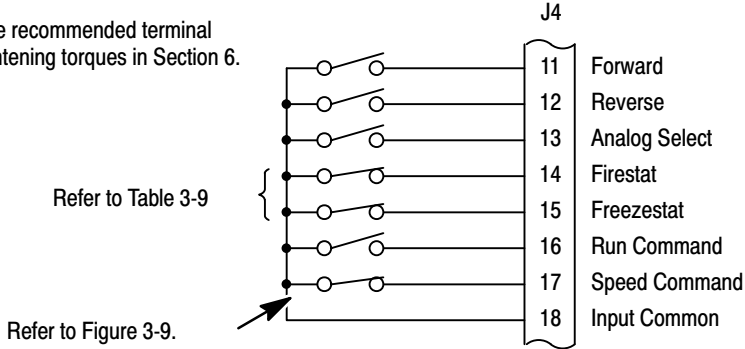

Table 3-9

Function	Firestat	Freezestat	Comment
ANA CMD Select	Closed	Closed	Firestat and Freezestat are alarm inputs that override all speed commands including the keypad.
Preset Speed 1	Open	Closed	
Preset Speed 1	Open	Open	
Preset Speed 2	Closed	Open	

- J4-11 OPEN motor decels to stop (depending on Keypad Stop mode).
CLOSED starts Forward motor rotation.
- J4-12 OPEN motor decels to stop (depending on Keypad Stop mode).
CLOSED starts Reverse motor rotation.
- J4-13 OPEN selects setting of “ANA CMD Select” parameter.
CLOSED selects Analog Input #1.
- J4-14 OPEN selects preset speed #1 regardless of the Speed Command input J4-13.
- J4-15 OPEN selects preset speed #2 regardless of the Speed Command input J4-13.
- J4-16 OPEN selects direction commands from Keypad.
CLOSED selects direction commands from terminal strip.
- J4-17 OPEN selects speed commanded from Keypad.
CLOSED selects terminal strip speed source (selected in the Level 1 Input block, ANA CMD Select parameter).

Fan Pump 3 Wire Connection

Figure 3-14 Fan/Pump 3 Wire Connection Diagram

See recommended terminal tightening torques in Section 6.

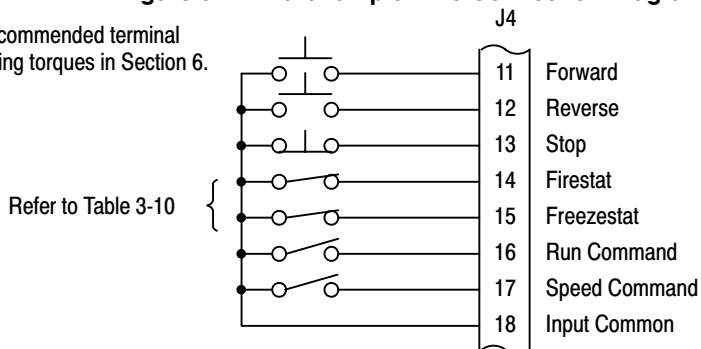

Table 3-10

Function	Firestat	Freezestat	Comment
ANA CMD Select	Closed	Closed	Firestat and Freezestat are alarm inputs that override all speed commands including the keypad.
Preset Speed 1	Open	Closed	
Preset Speed 1	Open	Open	
Preset Speed 2	Closed	Open	

- J4-11 Momentary CLOSED starts Forward motor rotation.
- J4-12 Momentary CLOSED starts Reverse motor rotation.
- J4-13 Momentary OPEN motor decels to stop (depending on Keypad Stop mode).
- J4-14 OPEN selects preset speed #1 regardless of the Speed Command input J4-13. CLOSED allows normal operation.
- J4-15 OPEN selects preset speed #2 regardless of the Speed Command input J4-13. CLOSED allows normal operation.
- J4-16 OPEN selects direction commands from Keypad. CLOSED selects direction commands from terminal strip.
- J4-17 OPEN selects speed commanded from Keypad. CLOSED selects terminal strip speed source (selected in the Level 1 Input block, ANA CMD Select parameter).

Process Control Connection

Figure 3-15 Process Control Connection Diagram

See recommended terminal
tightening torques in Section 6.

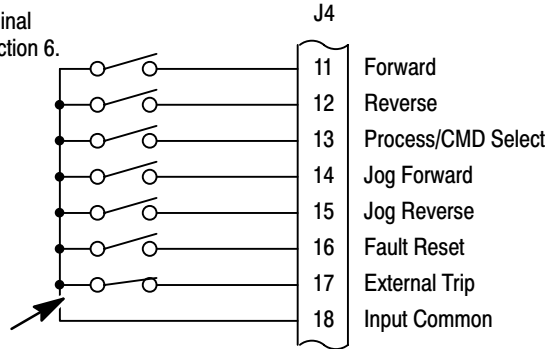

J4-11 OPEN motor decels to stop (depending on Keypad Stop mode).
CLOSED starts Forward motor rotation.

J4-12 OPEN motor decels to stop (depending on Keypad Stop mode).
CLOSED starts Reverse motor rotation.

Note: Simultaneous closure of J4-11 and J4-12 will cause the motor to regen to stop (not coast).

J4-13 OPEN selects the input specified in the Level 1 Input block,
ANA CMD Select parameter.
CLOSED selects the closed loop feature of the Process Control mode.

Note: The process will run in one direction. For example, if the forward line (J4-11) is closed, the process will only run in the forward direction. The PID algorithm will not reverse the direction automatically.

J4-14 OPEN allows normal operation.

CLOSED jogs the motor in the forward direction.

J4-15 OPEN allows normal operation.

CLOSED jogs the motor in the reverse direction.

Note: Simultaneous closure of J4-14 and J4-15 selects jog forward.

J4-16 OPEN allows normal operation.

CLOSED to reset a fault condition.

J4-17 If J4-17 is connected, you must set Level 2 Protection block, External Trip to "ON" to activate the opto input.

OPEN causes an external trip fault. The control will disable and the motor coasts to a stop. An external trip fault is displayed (also logged in the fault log).
CLOSED allows normal operation.

3 Speed Analog 2 Wire Connection

Figure 3-16 3 Speed Analog 2 Wire Connection Diagram

See recommended terminal tightening torques in Section 6.

Refer to Table 3-11

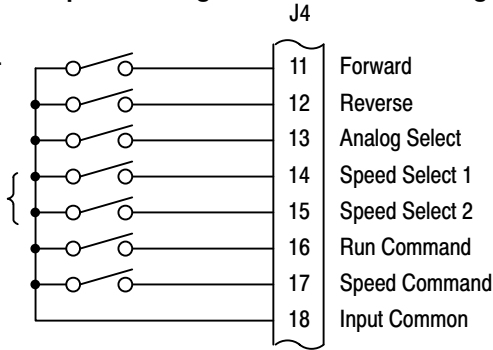

Table 3-11

Function	Speed Select 1	Speed Select 2
ANA CMD Select	Open	Open
Preset Speed 1	Closed	Open
Preset Speed 2	Closed	Closed
Preset Speed 3	Open	Closed

- J4-11 OPEN motor decels to stop (depending on Keypad Stop mode).
CLOSED starts Forward motor rotation.
- J4-12 OPEN motor decels to stop (depending on Keypad Stop mode).
CLOSED starts Reverse motor rotation.
- J4-13 OPEN selects setting of "ANA CMD Select" parameter.
CLOSED selects Analog Input #1.
- J4-14 Selects preset speeds as defined in Table 3-11.
- J4-15 Selects preset speeds as defined in Table 3-11.
- J4-16 OPEN selects direction commands from Keypad.
CLOSED selects direction commands from terminal strip.
- J4-17 OPEN selects speed commanded from Keypad.
CLOSED selects terminal strip speed source (selected in the Level 1 Input block, ANA CMD Select parameter).

3 Speed Analog 3 Wire Connection

Figure 3-17 3 Speed Analog 3 Wire Connection Diagram

See recommended terminal tightening torques in Section 6.

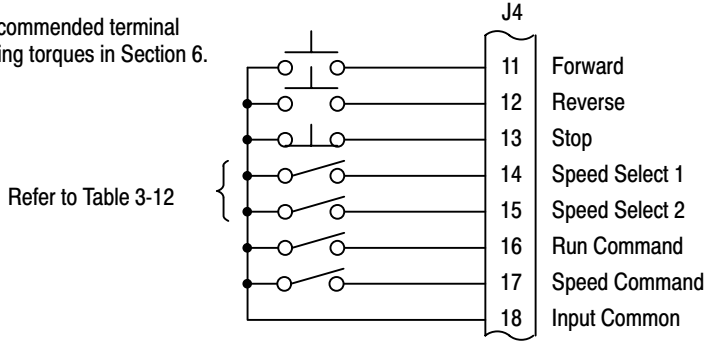

Table 3-12

Function	Speed Select 1	Speed Select 2
ANA CMD Select	Open	Open
Preset Speed 1	Closed	Open
Preset Speed 2	Closed	Closed
Preset Speed 3	Open	Closed

- J4-11 Momentary CLOSED starts Forward motor rotation.
- J4-12 Momentary CLOSED starts Reverse motor rotation.
- J4-13 Momentary OPEN motor decels to stop (depending on Keypad Stop mode).
- J4-14 Selects preset speeds as defined in Table 3-12.
- J4-15 Selects preset speeds as defined in Table 3-12.
- J4-16 OPEN selects direction commands from Keypad.
CLOSED selects direction commands from terminal strip.
- J4-17 OPEN selects speed commanded from Keypad.
CLOSED selects terminal strip speed source (selected in the Level 1 Input block, ANA CMD Select parameter).

EPOT 2 Wire Connection

Figure 3-18 Electronic POT 2 Wire Connection Diagram

See recommended terminal tightening torques in Section 6.

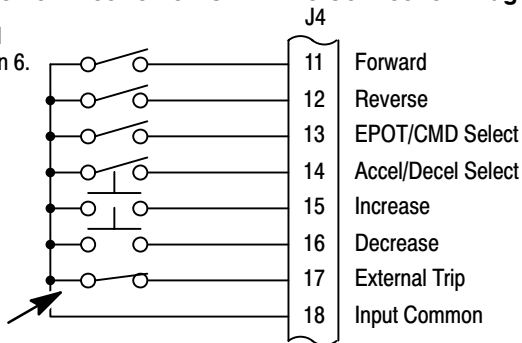

Refer to Figure 3-9.

- J4-11 OPEN motor decels to stop (depending on Keypad Stop mode).
CLOSED to enable operation in the Forward direction.
- J4-12 OPEN motor decels to stop (depending on Keypad Stop mode).
CLOSED to enable operation in the Reverse direction.
- J4-13 OPEN for normal speed mode. Terminal strip speed source is selected in the Level 1 Input block, ANA CMD Select parameter.
CLOSED to enable the Electronic Potentiometer Mode.
- J4-14 OPEN selects ACC / DEC / S-CURVE group 1.
CLOSED selects group 2.
- J4-15 Momentary CLOSED increases motor speed while closed.
- J4-16 Momentary CLOSED decreases motor speed while closed.
- J4-17 If J4-17 is connected, you must set Level 2 Protection block, External Trip to "ON" to activate the opto input.
OPEN causes an external trip fault. The control will disable and the motor coasts to a stop. An external trip fault is displayed (also logged in the fault log).
CLOSED allows normal operation.

EPOT 3 Wire Connection

Figure 3-19 Electronic POT 3 Wire Connection Diagram

See recommended terminal tightening torques in Section 6.

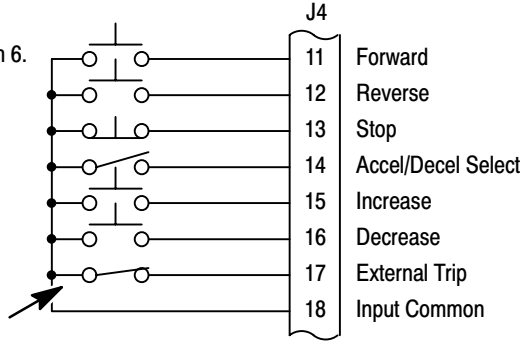

- J4-11 Momentary CLOSED starts Forward motor rotation.
- J4-12 Momentary CLOSED starts Reverse motor rotation.
- J4-13 Momentary OPEN motor decels to stop (depending on Keypad Stop mode).
- J4-14 OPEN selects ACC / DEC / S-CURVE group 1.
CLOSED selects group 2.
- J4-15 Momentary CLOSED increases motor speed while closed.
- J4-16 Momentary CLOSED decreases motor speed while closed.
- J4-17 If J4-17 is connected, you must set Level 2 Protection block, External Trip to "ON" to activate the opto input.
OPEN causes an external trip fault. The control will disable and the motor coasts to a stop. An external trip fault is displayed (also logged in the fault log).
CLOSED allows normal operation.

Pre-Operation Checklist Check of electrical items.

1. Verify AC line voltage at source matches control rating.
2. Inspect all power connections for accuracy, workmanship and tightness as well as compliance to codes.
3. Verify control and motor are grounded to each other and the control is connected to earth ground.
4. Check all signal wiring for accuracy.
5. Be certain all brake coils, contactors and relay coils have noise suppression. This should be an R-C filter for AC coils and reverse biased diodes for DC coils. MOV type transient suppression is not adequate for noise suppression.

Check of Motor and Couplings

1. Verify freedom of motion of motor shaft.
2. Verify that all motor couplings are tight without backlash.
3. If holding brakes are used, verify they are properly adjusted to fully release and set to the desired torque value.

Power-up Procedure

1. Turn power on. Be sure no faults are displayed on the keypad display.
2. Set the Level 1 Input block, Operating Mode to "Keypad".
3. Set the Level 2 Output Limits block, "MIN Output FREQ" parameter.
4. Set the Level 2 Output Limits block, "MAX Output FREQ" parameter.
5. If the desired peak current limit setting is not correct, set the Level 2 Output Limits block, "PK Current Limit" parameter as desired.
6. Enter the following motor data in the Level 2 Motor Data block parameters:
Motor Rated Amps (FLA)
Motor Rated Speed (base speed)
Motor Rated Frequency (Nameplate)
7. If External Dynamic Brake hardware is used, set the Level 2 Brake Adjust block parameters as desired.
8. Set the Level 1 V/Hz Boost block, "V/Hz Profile" parameter for the correct V/Hz ratio for your application.
9. If the load is a high initial starting torque type, the torque boost and Accel time may need to be increased. Set the Level 1 V/Hz Boost block, "Torque Boost" and the Level 1 Accel/Decel Rate block, "ACCEL TIME #1" as required.
10. Select and program additional parameters to suit your application.

The control is now ready for use in keypad mode. The terminal strip wiring may be changed and different parameter values used for another operating mode.

Section 4

Programming and Operation

Overview The keypad is used to program the control parameters, to operate the motor and to monitor the status and outputs of the control (by accessing the display options, diagnostic menus and the fault log).

Figure 4-1 Keypad

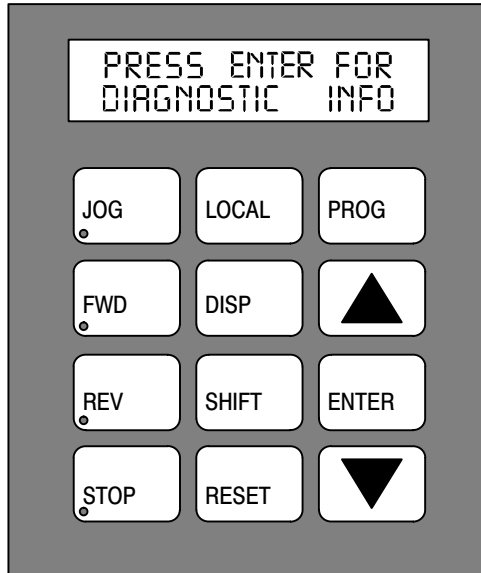
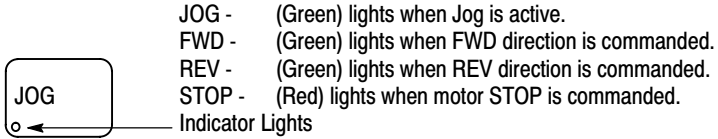

JOG

Press JOG to select the preprogrammed jog speed. After the jog key has been pressed, use the FWD or REV keys to run the motor in the direction that is needed. The JOG key is only active in the local mode.

FWD

Press FWD to initiate forward rotation of the motor.

REV

Press REV to initiate reverse rotation of the motor.

STOP

Press STOP to initiate a stop sequence. Depending on the setup of the control, the motor will either regen or coast to a stop. This key is operational in all modes of operation unless it has been disabled by the Keypad Stop parameter in the Keypad (programming) Setup Block.

LOCAL

Press LOCAL to change between the local (keypad) and remote operation.

DISP

Press DISP to return to display mode from programming mode. In the Diagnostic menu, pressing this key will advance to the next diagnostic screen.

SHIFT

Press SHIFT in the program mode to control cursor movement. Pressing the SHIFT key once moves the blinking cursor one character position to the right. While in program mode, a parameter value may be reset to the factory preset value by pressing the SHIFT key until the arrow symbols at the far left of the keypad display are flashing, then press an arrow key.

RESET

Press RESET to clear all fault messages (in local mode). This key can also be used to return to the top of the block programming menu without saving any parameter value changes.

PROG

Press PROG to enter the program mode to check or to edit a parameter value.

▲ - (UP Arrow)

Press ▲ to change the value of the parameter being displayed. Pressing ▲ increments the value to the next greater value. Also, when the fault log or parameter list is displayed, the ▲ key will scroll upward through the list. In the local mode pressing the ▲ key will increase motor speed to the next greater value.

ENTER

Press ENTER to save parameter value changes and move back to the previous level in the programming menu. In the display mode the ENTER key is used to directly set the Local Speed Reference.

▼ - (Down Arrow)

Press ▼ to change the value of the parameter being displayed. Pressing ▼ decrements the value to the next lesser value. Also, when the fault log or parameter list is displayed, the ▼ key will scroll downward through the list. In the local mode pressing the ▼ key will decrease motor speed to the next lesser value.

Operation Examples

Operating the Control from the Keypad

If the control is configured for remote or serial control, the LOCAL Mode must be activated before the control may be operated from the keypad. To activate the LOCAL Mode, first the motor must be stopped using the keypad STOP key (if enabled), remote commands or serial commands.

Note: Pressing the keypad STOP key (if enabled) will automatically issue a motor stop command and change to LOCAL mode.

When the motor has stopped, the LOCAL Mode is activated by pressing the "LOCAL" key. Selection of the LOCAL Mode overrides any remote or serial control inputs except for the External Trip input, Local Enable Input or STOP input.

The control can operate the motor in three (3) different ways from the keypad.

1. JOG Command.
2. Speed adjustment with Keypad entered values.
3. Speed adjustment using the Keypad arrow keys.

Note: If the control has been configured for Keypad in the operating mode parameter (level 1, input block), then no other means of operation is permitted other than from the keypad.

Accessing the Keypad JOG Command

Action	Description	Display						
Apply Power	If no faults and programmed for LOCAL operation.	<table border="1"><tr><td>STP</td><td>0V</td><td>0 RPM</td></tr><tr><td>LOC</td><td>0.0 A</td><td>0.0 HZ</td></tr></table>	STP	0V	0 RPM	LOC	0.0 A	0.0 HZ
STP	0V	0 RPM						
LOC	0.0 A	0.0 HZ						
Press JOG key	Access programmed JOG speed.	<table border="1"><tr><td>STP</td><td>0V</td><td>0 RPM</td></tr><tr><td>LOC</td><td>0.0 A</td><td>0.0 HZ</td></tr></table>	STP	0V	0 RPM	LOC	0.0 A	0.0 HZ
STP	0V	0 RPM						
LOC	0.0 A	0.0 HZ						
Press and hold FWD or REV key	Move control forward or reverse at JOG speed.	<table border="1"><tr><td>FWD</td><td>45V</td><td>208RPM</td></tr><tr><td>LOC</td><td>0.3A</td><td>7.00HZ</td></tr></table>	FWD	45V	208RPM	LOC	0.3A	7.00HZ
FWD	45V	208RPM						
LOC	0.3A	7.00HZ						
Press JOG key	Disables JOG mode.	<table border="1"><tr><td>STP</td><td>0V</td><td>0 RPM</td></tr><tr><td>LOC</td><td>0.0 A</td><td>0.0 HZ</td></tr></table>	STP	0V	0 RPM	LOC	0.0 A	0.0 HZ
STP	0V	0 RPM						
LOC	0.0 A	0.0 HZ						

Speed Adjustment using Local Speed Reference

Speed Adjustment using Local Speed Reference.

(This example changes the Local Speed Ref parameter from 0Hz to 10Hz).

Action	Description	Display
Apply Power	If no faults and programmed for LOCAL operation.	STP 0V 0 RPM LOC 0.0 A 0.0 HZ
Press ENTER key	Select the local speed reference.	LOCAL SPEED REF 000.00 0.00 HZ
Press SHIFT key	Move blinking cursor right one digit.	LOCAL SPEED REF 000.00 0.00 HZ
Press ▲ key	Increase tens value by one digit.	LOCAL SPEED REF 010.00 0.00 HZ
Press ENTER key	Save new value and return to display mode.	STP 0V 0 RPM LOC 0.0 A 0.0 HZ
Press FWD or REV key	Motor runs FWD or REV at commanded speed.	FWD 230V 300 RPM LOC 2.0A 10.0HZ
Press STOP key	Motor stop command issued.	STP 0V 0 RPM LOC 0.0 A 0.0 HZ

Speed Adjustment using Arrow Keys

Action	Description	Display
Apply Power	If no faults and programmed for LOCAL operation.	STP 0V 0 RPM LOC 0.0 A 0.0 HZ
Press FWD or REV key	Motor runs FWD or REV at selected speed.	FWD 0V 0 RPM LOC 0.0A 0.0HZ
Press ▲ key	Increase motor speed.	FWD 230V 300 RPM LOC 2.0A 10.0HZ
Press ▼ key	Decrease motor speed.	FWD 0V 0 RPM LOC 0.0A 0.0HZ
Press ▲ key	Increase motor speed.	FWD 230V 300 RPM LOC 2.0A 10.0HZ
Press STOP key	Motor stop command issued.	STP 0V 0 RPM LOC 0.0 A 0.0 HZ
Press FWD or REV key	Motor runs FWD or REV at commanded speed.	FWD 230V 300 RPM LOC 2.0A 10.0HZ
Press STOP key	Motor stop command issued.	STP 0V 0 RPM LOC 0.0 A 0.0 HZ

Display Mode

During normal operation the controller is in the display mode and the keypad displays the status of the control. Several output status values can be monitored.

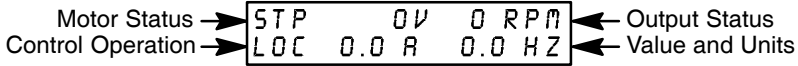

The display mode also gives the user the ability to view diagnostic information and the fault log.

Adjusting Display Contrast

When AC power is applied to the control the keypad should display the status of the control. If there is no display visible, use the following procedure to adjust the display.

Action	Description	Display
Apply Power	No visible display	
Press DISP Key	Places control in display mode	
Press SHIFT SHIFT	Allows display contrast adjustment	
Press ▲ or ▼ Key	Adjusts display intensity	ADJUST CONTRAST ⬇ (ENTER) TO SAVE
Press ENTER	Saves level of contrast and exits to display mode	STP 0V 0 RPM LOC 0.0 A 0.0 HZ

Display Screens

Action	Description	Display
Apply Power	Display of mode & drive status.	<pre>STP 0V 0 RPM LOC 0.0 A 0.0 HZ</pre>
Press DISP key	The fault log block.	<pre>PRESS ENTER FOR FAULT LOG</pre>
Press DISP key	The diagnostic information block.	<pre>PRESS ENTER FOR DIAGNOSTIC INFO</pre>
Press DISP key	The modified parameters block.	<pre>PRESS ENTER FOR MODIFIED PARAMS</pre>
Press DISP key	Display of output frequency.	<pre>STOP FREQUENCY LOCAL 0.00 HZ</pre>
Press DISP key	Display of motor speed (based on output frequency).	<pre>STOP MOTOR SPEED LOCAL 0 RPM</pre>
Press DISP key	Display of motor current.	<pre>STOP CURRENT OUT LOCAL 0.00 A</pre>
Press DISP key	Display of motor voltage.	<pre>STOP VOLTAGE OUT LOCAL 0 V</pre>

Fault Log Access

When a fault condition occurs, motor operation stops and a fault code is displayed on the Keypad display. The control keeps a log of the last 31 faults. If more than 31 faults have occurred the oldest fault will be deleted from the fault log to make room for the newest fault. To access the fault log perform the following procedure:

Action	Description	Display
Apply Power	Display of mode & drive status.	<pre>STP 0V 0 RPM LOC 0.0 A 0.0 HZ</pre>
Press DISP key	Press DISP to scroll to the Fault Log entry point.	<pre>PRESS ENTER FOR FAULT LOG</pre>
Press ENTER key	Display first fault type and time fault occurred.	<pre>EXTERNAL TRIP 1: 3:00:30</pre>
Press ▲ key	Scroll through fault messages to the end.	<pre>PRESS ENTER FOR FAULT LOG EXIT</pre>
Press RESET key	Return to display mode.	<pre>STP 0V 0 RPM LOC 0.0 A 0.0 HZ</pre>

Diagnostic Information Access

Action	Description	Display
Apply Power	Display of mode & drive status.	STP 0V 0 RPM LOC 0.0 A 0.0 HZ
Press DISP key several times	Scroll to Diagnostic Info entry point.	PRESS ENTER FOR DIAGNOSTIC INFO
Press ENTER key	Access diagnostic information.	STOP FREQ REF LOCAL 2.00 HZ
Press DISP key	Control temperature.	STOP CONTROL TMP LOCAL 25.0° C
Press DISP key	Bus voltage.	STOP BUS VOLTAGE LOCAL 321V
Press DISP key	PWM Frequency.	STOP PWM FREQ LOCAL 2500 HZ
Press DISP key	% overload current remaining.	STOP OVRLD LEFT LOCAL 100.00%
Press DISP key	Display of HP, voltage, rated peak & continuous current.	2.0HP 230V 6.8A 13.6APK
Press DISP key	Real time opto inputs & relay outputs states. (0=Open, 1=Closed)	DIGITAL I/O 0000000 0
Press DISP key	Display of Analog Inputs.	ANA IN1: 1.1% ANA IN2: 0.03V
Press DISP key	(Displayed in Process Control mode only) Display of "Proportional", "Integral" and "Derivative" terms.	PID TERMS 0 0 0
Press DISP key	(Displayed in Process Control mode only) Display of "Feedforward" (1st line), "Setpoint" and "Feedback" equiv. freq. (2nd line, left to right)	PROC.CTL 0.00HZ 0.00HZ 0.00HZ
Press DISP key	Operating time.	ACCUMULATED TIME 000111:09:45
Press DISP key	Display of software version.	USER INT 15JX.XX MOTOR CTL X.XX
Press DISP key	Displays exit choice. Press ENTER to exit.	PRESS ENTER FOR DIAGNOSTIC EXIT

Note: In Diagnostic mode only, press DISP to display next item or press SHIFT to display previous item.

Program Mode

Use the Program Mode to customize the control for a variety of applications by programming the operating parameters. In the Display Mode, press the PROG key to access the Program Mode. To return to the Display Mode, press the DISP key. Note that when a parameter is selected alternately pressing the DISP and PROG keys will change between the Display Mode and the selected parameter. Parameters may be programmed in any operating mode. When a parameter is selected for programming, the keypad display gives you the following information:

Parameter → PRESET SPEED #1
 Parameter Status → P: 10.00 HZ ← Value and Units

Parameter Status

All programmable parameters are displayed with a P: in the lower left hand corner of the keypad display. If a parameter is displayed with a V:, the setting may be viewed but not changed while the motor is operating. If the parameter is displayed with an L:, the setting is locked and the security access code must be entered before any changes can be made.

Parameter Blocks Access for Programming

Use the following procedure to access parameter blocks to program the control.

Action	Description	Display
Apply Power	If no faults and programmed for LOCAL operation.	STP 0V 0 RPM LOC 0.0 R 0.0 HZ
	If no faults and programmed for REMOTE operation.	STP 0V 0 RPM REM 0.0 R 0.0 HZ
	If fault is displayed, refer to the Troubleshooting section of this manual.	
Press PROG key		PRESS ENTER FOR PRESET SPEEDS
Press ▲ or ▼ key	Scroll to the ACCEL/DECEL block.	PRESS ENTER FOR ACCEL/DECEL RATE
Press ▲ or ▼ key	Scroll to the Level 2 Block.	PRESS ENTER FOR LEVEL 2 BLOCKS
Press ENTER key	First level 2 block display.	PRESS ENTER FOR OUTPUT LIMITS
Press ▲ or ▼ key	Scroll to Programming Exit menu.	PRESS ENTER FOR PROGRAMMING EXIT
Press ENTER key	Return to display mode.	STP 0V 0 RPM LOC 0.0 R 0.0 HZ

Changing Parameter Values

Use the following procedure to program or change a parameter value.

Action	Description	Display
Apply Power	If no faults and programmed for LOCAL operation.	STP 0V 0 RPM LOC 0.0 A 0.0 HZ
Press PROG key	Access programming mode.	PRESS ENTER FOR PRESET SPEEDS
Press ▲ or ▼ key	Scroll to Level 1 Input Block.	PRESS ENTER FOR INPUT
Press ENTER key	Access Input Block.	OPERATING MODE P: KEYPAD
Press ENTER key	Access Operating Mode.	OPERATING MODE ◄ □ KEYPAD
Press ▲ key	Scroll to make your selection.	OPERATING MODE ◄ □ STANDARD RUN
Press ENTER	Save selection to memory.	OPERATING MODE P: STANDARD RUN
Press ▲ key	Scroll to menu exit.	PRESS ENTER FOR MENU EXIT
Press ENTER key	Return to Input Block.	PRESS ENTER FOR INPUT
Press ▲ or ▼ key	Scroll to Programming Exit menu.	PRESS ENTER FOR PROGRAMMING EXIT
Press ENTER key	Return to display mode.	STP 0V 0 RPM LOC 0.0 A 0.0 HZ

Reset Parameters to Factory Settings

Sometimes it is necessary to restore the parameter values to the factory settings (after new software is installed, etc.). This procedure describes how to restore factory settings.

Note: All parameter values already programmed will be changed when resetting the control to factory settings.

Action	Description	Display
Apply Power	If no faults and programmed for LOCAL operation.	<pre>STP 0V 0 RPM LOC 0.0 R 0.0 HZ</pre>
Press PROG key	Enter program mode.	<pre>PRESS ENTER FOR PRESET SPEEDS</pre>
Press ▲ or ▼ key	Scroll to Level 2 Blocks.	<pre>PRESS ENTER FOR LEVEL 2 BLOCKS</pre>
Press ENTER key	Select Level 2 Blocks.	<pre>PRESS ENTER FOR OUTPUT LIMITS</pre>
Press ▲ or ▼ key	Scroll to the Miscellaneous block.	<pre>PRESS ENTER FOR MISCELLANEOUS</pre>
Press ENTER key	Select Miscellaneous block.	<pre>FACTORY SETTING P: NO</pre>
Press ENTER key	Access Factory Settings parameter.	<pre>FACTORY SETTINGS ⬆ □ NO</pre>
Press ▲ key	Scroll to YES, to choose original factory settings.	<pre>FACTORY SETTINGS ⬆ □ YES</pre>
Press ENTER key	Restores factory settings.	<pre>FACTORY SETTING OPERATION DONE</pre>
Press RESET key	Return to Miscellaneous block.	<pre>PRESS ENTER FOR MISCELLANEOUS</pre>
Press ▲ key	Scroll to menu exit.	<pre>PRESS ENTER FOR MENU EXIT</pre>

Parameter Definitions (Interface Version 2.01) – Level 1 Blocks

Preset Speeds	Output
Preset Speed #1	Relay Output
Preset Speed #2	Zero SPD Set Pt
Preset Speed #3	At Speed Band
Preset Speed #4	Set Speed Point
Preset Speed #5	Overload Set Pt
Preset Speed #6	Underload Set Pt
Preset Speed #7	Analog Out Type
	Analog Out
	Analog Scale
Accel / Decel Rate	
Accel Time #1	
Decel Time #1	
S-Curve #1	
Accel Time #2	
Decel Time #2	
S-Curve #2	
Jog Settings	
Jog Speed	
Jog Accel Time	
Jog Decel Time	
Jog S-Curve	
Input	
Operating Mode	
ANA CMD Select	
ANA CMD Inverse	
ANA CMD Offset	
ANA CMD Gain	
ANA CMD Filter	
	Keypad Setup
	Keypad Stop Key
	Keypad Stop Mode
	Keypad Run FWD
	Keypad Run REV
	Keypad Jog FWD
	Keypad Jog REV
	Switch On Fly
	Loc. Hot Start
	V/HZ and Boost
	Ctrl Base Frequency
	Torque Boost
	Dynamic Boost
	Slip Comp Adj
	V/HZ Profile
	3-PT Operation
	3-PT Volts
	3-PT Frequency
	Max Output Volts

Parameter Definitions – Level 2 Blocks

Output Limits	Brake Adjust Continued
Min Output Frequency	Brake on Reverse
Max Output Frequency	Stop Brake Time
PK Current Limit	Brake on Start
PWM Frequency	Start Brake Time
Protection	Process Control
External Trip	Process Feedback
Foldback Protect	Process Inverse
	Setpoint Source
Miscellaneous	Setpoint Command
Restart Auto/Man	Set PT Adj limit
Restart Fault/Hr	At Setpoint Band
Restart Delay	Process PROP Gain
Language Select	Process INT Gain
Factory Settings	Process DIFF Gain
Security Control	Skip Frequency
Security State	Skip Frequency #1
Access Timeout	Skip Band #1
Access Code	Skip Frequency #2
	Skip Band #2
Motor Data	Skip Frequency #3
Motor Rated Amps	Skip Band #3
Motor Rated Speed	
Motor Rated Frequency	Synchro Starts
	Sync Start Enable
Brake Adjust	Sync Scan V/F
Resistor Ohms	Sync Setup Time
Resistor Watts	Sync Scan Time
DC Brake Voltage	
DC Brake Frequency	
Brake on Stop	

Parameter Block Definitions Level 1

PRESET SPEEDS

Preset Speeds #1 – #7 Allows selection of 7 predefined motor operating speeds. Each speed may be selected using external switches connected to the control terminal strip (J4). For motor operation, a motor direction command must be given along with a preset speed command (at J4).

ACCEL/DECCEL RATE

Accel Time #1,2 Accel time is the number of seconds required for the control to increase the output frequency from the “Min Output Frequency” to the frequency specified in the “Max Output Frequency” parameter in the Level 2 Output Limits block.

Decel Time #1,2 Decel time is the number of seconds required for the control to decrease the output frequency from the frequency specified in the “Max Output Frequency” parameter to the “Min Output Frequency”.

S-Curve #1,2 S-Curve is a percentage of the total Accel or Decel time. It is non-linear to provides smooth starts and stops. Figure 4-2 illustrates how motor acceleration and deceleration is changed using a 40% S-Curve. 0% represents no “S” and 100% represents full “S” with no linear segment.

Figure 4-2 40% S-Curve Example

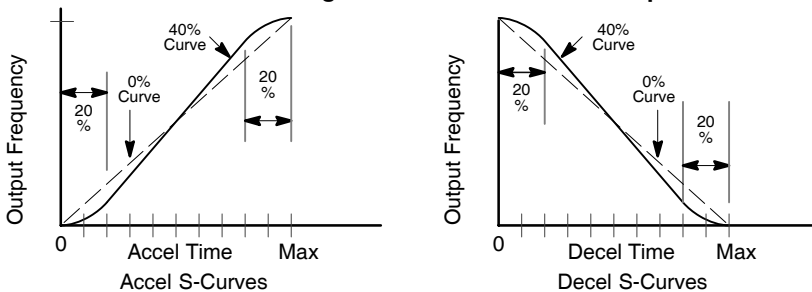

Example: Maximum Output frequency =100 Hz; Preset frequency = 50 Hz, Accel Time=10 Sec. In this example, control output frequency will be 50Hz, 5 seconds after commanded from minimum output frequency.

Note: Accel #1, Decel #1 and S-Curve #1 are associated together. Likewise, Accel #2, Decel #2 and S-Curve #2 are associated together. These associations can be used to control any preset speed or external speed command (Pot).

Note: Since the motor design uses rotor slip to produce torque, the motor speed will not necessarily increase/decrease in a linear manner with motor frequency.

Note: If faults (motor trips) occur during rapid Accel or Decel, selecting an S-curve may eliminate the faults without affecting the overall ramp time. Some adjustment of Accel, Decel and S-Curve settings may be necessary to optimize your application.

JOG SETTINGS

Jog Speed Jog Speed is the commanded frequency used during jog. Jog speed can be initiated from the keypad or terminal strip. At the keypad, first press the JOG key then either the FWD or REV key.

Jog Accel Time is the Accel Time used during jog.

Jog Decel Time is the Decel Time used during jog.

Jog S-Curve is the S-Curve used during jog.

Parameter Block Definitions Level 1 Continued

INPUT

Operating Mode The “Operating Modes” are: Keypad, Standard Run, 7 Speed, Fan Pump 2 Wire, Fan Pump 3 Wire, Process Control, 3 Speed Analog 2 Wire, 3 Speed Analog 3 Wire, EPOT 2Wire, EPOT 3Wire. External connections to the control are made at the J4 terminal strip (wiring diagrams are shown in Section 3).

ANA CMD Select Selects the external speed reference to be used.

Potentiometer is the simplest method of speed control. Select Potentiometer and connect a 5K Ω pot at J4-4, J4-5, and J4-6.

0-5 or 0-10VDC input is selected when an input voltage signal is applied to J4-7 and J4-8.

4-20mA or 0-20mA selection should be considered if long distance is required between the external device and the control. Current loop allows longer cable lengths at J4-7 and J4-8 with less attenuation of the command signal.

None no external reference is selected.

ANA CMD Inverse “ON” will cause a low input voltage (e.g. 0VDC) to be a maximum motor speed command and a maximum input voltage (e.g. 10VDC) to be a low motor speed command.

“OFF” will cause a low input voltage (e.g. 0VDC) to be a low motor speed command and a maximum input voltage (e.g. 10VDC) to be a maximum motor speed command.

ANA CMD Offset Provides an offset to the Analog Input to minimize signal drift. For example, if the minimum speed signal is 1VDC (instead of 0VDC) the ANA CMD Offset can be set to -10% so the minimum voltage input is seen by the control as 0VDC.

ANA CMD Gain Provides a gain factor for the analog speed reference input signal. For example, if the analog speed reference signal is 0 - 9VDC, setting the ANA CMD Gain to 111% allows the control to see 0 - 10VDC as the input signal.

ANA CMD Filter Provides filtering for the analog speed reference input signal. The greater the number (0 - 6) the more noise filtering is provided. For faster response, use a smaller number.

OUTPUT

Relay Output N.O. and N.C. relay outputs that may be configured to any of the following conditions:

Ready Active when power is applied and no faults are present.

Zero Speed Active when output frequency is less than the value of the “Zero SPD Set Pt” Level 1 Output parameter.

At Speed Band Active when output frequency is within the commanded range defined by the “At Speed Band” Level 1 Output parameter.

At Set Speed Active when output frequency is at or greater than the “Set Speed Point” Level 1 Output parameter.

Overload Output is active if the output current is greater than value of the Overload Set Point parameter value.

Underload Output is active if the output current is less than the value of the Underload Set Point parameter.

Keypad Control Active when control is in local (keypad) control.

Parameter Block Definitions Level 1 Continued

OUTPUT Continued

Fault Active when a fault condition is present.

Drive On Active when control is "Ready" and is being commanded to operate the motor.

Reverse Active when control is operating in the reverse direction.

Process Error Active when the PID control loop process is outside the range specified by the Level 2 Process Control block, AT Setpoint band parameter.

Zero SPD Set PT The output frequency at which the zero speed relay output becomes active (turns on). When the output frequency is less than the Zero SPD Set PT, the relay output becomes active. This is useful in applications where a motor brake will be interlocked into the operation of the motor control.

At Speed Band A frequency band within which the at speed relay output becomes active (turns on). For example, if the at speed band is set to $\pm 5\text{Hz}$ the relay output becomes active when the output frequency to the motor is within 5Hz of the commanded motor frequency. This is useful when another machine must not start (or stop) until the motor reaches operating speed.

Set Speed Point The frequency at which the at set speed relay output becomes active (turns on). When the frequency is greater than the set speed point parameter, the relay output becomes active. This is useful when another machine must not start (or stop) until the motor exceeds a predetermined speed.

Overload Set Point When the output current exceeds this value, the overload output is turned on.

Underload Set Point When the output current is less than this value, the underload output is turned on.

Analog OUT Type 0-10VDC, 0-5VDC, 4-20mA or 0-20mA.

Analog Output Analog output that may be configured to represent one of the following conditions:

Frequency Represents the output frequency; where max output = MAX Hz (slip freq. compensation is not included).

Freq Command Represents the commanded frequency where max output = MAX Hz.

AC Current Represents the value of the output current where max output = Full load current (A_{RMS}).

AC Voltage Represents the value of the output voltage where max output = Control Input Voltage.

Bus Voltage Represents motor power where half max output = 325VDC for 230VAC input (650VDC for 460VAC input).

Control Temp Represents the heat sink temperature of the control where max output = maximum heat sink temperature.

Process Feedback Represents the process feedback signal where max output = 100% feedback signal.

Set Point Command Represents the setpoint command value where max output = 100% commanded value.

Zero Cal Output is minimum used to calibrate an external meter.

100% Cal Output is maximum used to calibrate an external meter.

Analog Scale Scale factor for the Analog Output voltage.
Useful to set the full scale range for external meters.

KEYPAD SETUP

- Keypad Stop Key** Allows keypad STOP key to initiate motor stop during remote or serial operation (if set to Remote ON). Pressing STOP initiates the stop command and automatically selects Local mode.
- Keypad Stop Mode** Causes the motor to coast to a stop or regen to a stop for a stop command. In coast, the motor is turned off and allowed to coast to a stop. In regen, the voltage and frequency to the motor is reduced at a rate set by the decel time.
- Keypad Run FWD ON** makes the keypad FWD key active in Local.
- Keypad Run REV** ON makes the keypad REV key active in Local.
- Keypad Jog FWD ON** makes the keypad FWD key active in Local Jog.
- Keypad Jog REV** ON makes the keypad REV key active in Local Jog.
- Switch On Fly ON** allows switching from Local to Remote mode or back without stopping the drive.
- Loc. Hot Start ON** allows the stop input to be used in keypad mode.

V/HZ AND BOOST

- CTRL Base FREQ** Represents the point on the V/Hz profile where output voltage becomes constant with increasing output frequency. This is the point at which the motor changes from constant or variable torque to constant horsepower operation. In some cases the Max Output Volts and CTRL Base Freq values can be manipulated to provide a wider constant torque or wider constant horsepower speed range than is normally available with the motor.
- Torque Boost** Adjusts the amount of motor starting torque. The boost adjustment alters the output voltage to the motor from the normal voltage value by increasing or decreasing the starting voltage by fixed values as defined by the V/Hz profile. The factory setting is suitable for most applications. Increasing the boost may cause the motor to overheat. If adjustment is required, increase the boost in small increments until the motor shaft just starts to rotate with maximum load applied.
- Slip Comp Adjustment** Compensates for varying load conditions during normal operation. This parameter sets the maximum allowable variation in output frequency under varying load conditions (changes of output current). As motor current increases toward 100% of Motor Rated Amps, output frequency is automatically increased to compensate for slip.
- V/Hz Profile** Sets the Volts/Frequency ratio of the control output (to the motor) for all values of output voltage versus output frequency up to the control base frequency. Because motor voltage is related to motor current, motor voltage can then be related to motor torque. A change in the V/Hz profile can adjust how much torque is available from the motor at various speeds.
- 3PT profile - allows two linear V/Hz segments by setting the V/Hz 3PT Volts and V/Hz 3PT Frequency parameters. 0% to 100% squared reduced may be selected for the V/Hz profile. (0% = Linear V/Hz Profile.)
- These profiles are shown in Figure 4-3.

Parameter Block Definitions Level 1 Continued

V/HZ AND BOOST Continued

3-PT Operation ON allows 3 point operation. OFF disables 3 point operation and the values of parameters V/Hz 3-PT Volts and V/Hz 3-PT Frequency are ignored.

V/Hz 3-PT Volts The output voltage associated with the 3PT Frequency parameter.

V/Hz 3-PT Frequency The output frequency associated with the 3PT Volts parameter.

Max Output Volts The maximum output voltage available to the motor from the control. This is useful if the motor rated voltage is less than the input line voltage. In some cases the Max Output Volts and the CTRL Base Frequency parameter values can be adjusted to provide a wider constant torque or wider constant horsepower speed range than is normally available.

Figure 4-3 Volts/Hertz Profile

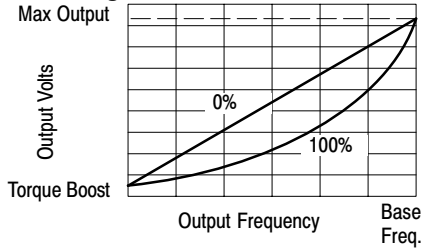

3 Point V/Hz Curve

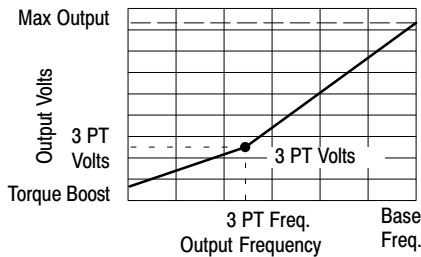

Parameter Block Definitions Level 2

OUTPUT LIMITS

MIN Output Frequency The minimum output frequency to the motor. During operation, the output frequency will not be allowed to go below this value except for motor starts from 0 Hz or during dynamic braking to a stop.

MAX Output Frequency The maximum output frequency to the motor.

PK Current Limit The maximum output (peak) current to the motor. Values above 100% of the rated current are available depending upon the operating zone selected.

PWM Frequency The frequency that the output transistors are switched. PWM should be as low as possible to minimize stress on the output transistors and motor windings. PWM frequency is also referred to as “Carrier” frequency.

PROTECTION

External Trip

OFF - External Trip is Disabled. (Ignores J4-17).

ON - External Trip is enabled. If a normally closed contact at J4-17 (to J4-18) is opened, an External Trip fault will occur and cause the drive to shut down.

Foldback Protect

OFF - Foldback protection is disabled.

ON - Acceleration rate is extended automatically to help prevent overcurrent trips during rapid acceleration.

MISCELLANEOUS

Restart Auto/Man

Manual If a fault occurs (or power loss), the control must be manually reset to resume operation.

Automatic - If a fault occurs (or power loss), the control will automatically reset (after restart delay) to resume operation.

Restart Fault/Hr The maximum number of automatic restart attempts before requiring a manual restart. After one hour without reaching the maximum number of faults or if power is turned off and on again, the fault count is reset to zero.

Restart Delay The amount of time allowed after a fault condition for an automatic restart to occur. Useful to allow sufficient time to clear a fault before restart is attempted.

Language Select Selects English, Spanish, French, German, Italian or Portuguese characters for keypad display.

Factory Settings Restores factory settings for all parameter values.

Select “YES” and press “ENTER” key to restore factory parameter values. The keypad Display will show “Operation Done” then return to “NO” when completed.

SECURITY CONTROL

Security State

Off - No security access code required to change parameter values.

Local Security - Requires security access code to be entered before changes can be made using the Keypad.

Access Timeout The time in seconds the security access remains enabled after leaving the programming mode. If you exit and go back into the program mode within this time limit, the security Access Code does not have to be re-entered. This timer starts when leaving the program mode (by pressing DISP etc.).

Access Code A 4 digit code. You must know this code to change secured Level 1 and Level 2 values.

Note: Please record your access code and store it in a safe place. If you cannot gain entry into parameter values to change a protected parameter, please contact Baldor. Be prepared to give the 5 digit code located on the lower right side of the Keypad Display at the Enter Code prompt.

MOTOR DATA

Motor Rated Amps The rated current of the motor (listed on the motor nameplate). If the motor current exceeds this value for a period of time, an Overload fault will occur. If multiple motors are used on one control, add the Motor Rated Amps for all motors and enter this value.

Motor Rated Speed The rated speed of the motor (listed on the motor nameplate). If Motor Rated SPD = 1750 RPM and Motor Rated Freq = 60 Hz, the Keypad Display will show 1750 RPM at 60 Hz and 875 RPM at 30Hz.

Motor Rated Freq The rated frequency of the motor (listed on the motor nameplate).

BRAKE ADJUST

Resistor Ohms The dynamic braking resistor value in ohms. Refer to Appendix A or call Baldor for additional information. If dynamic braking is not installed, enter zero.

Resistor Watts The dynamic braking resistor watts rating. Refer to dynamic braking manual or call Baldor for additional information. If dynamic braking is not installed, enter zero.

DC Brake Voltage The amount of DC braking voltage applied to the motor windings during a stop command. Increase this value for more braking torque during stops. The increased braking voltage may cause the motor to overheat for applications that require frequent starts/stops. Be careful in selecting this value.

The maximum DC Brake Voltage = $(1.414) \times (\text{Max Output Volts})$.

DC Brake FREQ The output frequency (to the motor) at which DC injection braking will begin during Decel.

Brake on Stop If ON, DC injection braking will begin when a stop command is issued. After a stop command, the DC brake voltage will be applied to the motor windings when the output frequency reaches the DC brake frequency.

Brake on Reverse If set to ON, DC injection braking will begin when the control is commanded to drive the motor in the opposite direction. Braking continues until the motor is stopped. The motor will then accelerate in the opposite direction.

Parameter Block Definitions Level 2 Continued

Stop Brake Time The maximum number of seconds that DC injection brake voltage will be applied to the motor windings after a stop command. After the time specified by this value, DC injection braking is automatically turned off. If DC injection braking starts at a frequency less than the DC brake frequency parameter, the stop brake time is calculated as follows:

$$\text{Brake Time} = \text{Stop Brake Time} \times \frac{\text{Output Frequency at Braking}}{\text{DC Brake Frequency}}$$

Brake on Start If set to ON, turns DC injection braking ON for a period of time (Start Brake Time) when a run command is issued. Braking will automatically turn off and the motor will accelerate at the end of the start brake time.

Start Brake Time The amount of time that DC injection braking will be applied after a run command is issued. This will only occur if brake on start is set to ON. Braking may cause the motor to overheat for applications that require frequent starts/stops. Be careful in selecting this value. The start brake time should be just long enough to ensure the motor shaft is not rotating when a start command is issued.

PROCESS CONTROL

Process Feedback The type of signal used for the process feedback in the PID setpoint control loop.

Process Inverse OFF – The process feedback signal is not inverted (no polarity change).

ON – Causes the process feedback signal to be inverted. Used with reverse acting processes that use a unipolar signal such as 4-20mA. If “ON”, the PID loop will see a low value of the process feedback signal as a high feedback signal and a high value of the process feedback signal as a low feedback signal.

Setpoint Source The source input reference signal type to which the process feedback will be compared. If “Setpoint CMD” is selected, a fixed value that is entered in the Setpoint Command parameter (of the Level 2 Process Control block) will be used.

Setpoint Command The setpoint value for the PID loop that the control will try to maintain. Used only when the setpoint source parameter is set to “Setpoint Command”.

Set PT ADJ Limit The maximum frequency correction value to be applied to the motor (in response to the maximum process error). For example, if the max output frequency is 60 Hz, the setpoint adjustment limit is 20%, the process error is 100% and the maximum speed the motor will run in response to the setpoint feedback error is ± 12 Hz. ($60\text{Hz} \times 20\% = 12\text{Hz}$ or a total of 24 Hz total output band-width centered around the effective setpoint frequency).

At Setpoint Band The operating band within which the At Setpoint opto output is active (turned ON). This feature indicates when the process is within the desired setpoint range. For example, if the setpoint source is 0-10VDC and the at setpoint band value is 10%, the at setpoint opto output will turn on if the process is within $(10 \times 10\% = 1) \pm 1\text{VDC}$ of the setpoint.

Process PROP Gain Sets the PID loop proportional gain or how much adjustment to motor speed is made to bring the process to the setpoint.

Process INT Gain The PID loop Integral gain or how much adjustment to motor speed is made to correct for long term error.

Process DIFF Gain The PID loop differential gain or how much adjustment to motor speed is made for short term error.

SKIP FREQUENCY

Skip Frequency (#1, #2 and #3) The center frequency of the frequency band to skip or treat as a speed command dead-band.

Skip Band (#1, #2 and #3) The width of the band centered about the Skip Frequency. For example, if Skip Frequency #1 is set to 20Hz and Skip Band #1 is set to 5Hz, continuous operation is not allowed in the dead-band of 15Hz to 25Hz.

Note: Three bands can be defined independently or the three values can be selected to skip one wide frequency band.

SYNCHRO STARTS

Sync Start Enable Allows Synchro Starts.

Sync Scan V/F Sets the Volts/Hertz ratio for the Synchro Starts feature as a percentage of the V/Hz ratio defined by the Max Output Volts/Base Frequency. This Sync Scan V/F percentage value is multiplied by the Max Output Volts/Base Frequency value. If this value is too high, the inverter may fault on Over-Current.

Sync Setup Time The time for the inverter to ramp the output voltage from zero to the voltage that corresponds to the frequency set by the "Sync at Max Freq" parameter. A 0.5 second delay before the ramp begins is not included in this time. If the Synchro Starts feature is not operating quickly enough, decrease the Sync Setup Time value.

Sync Scan Time The time allowed for Synchro Starts to scan and detect rotor frequency. Generally, the shorter the Sync Scan Time the more likely a false Synchro Starts will be detected. This value should be set high enough to eliminate false Synchro Starts.

Section 5

Troubleshooting

The Baldor Series 15J Control requires very little maintenance, if any, and should provide years of trouble free operation when installed and applied correctly.





Occasional visual inspection and cleaning should be considered to ensure tight wiring connections and to remove dust, dirt, or foreign debris which can reduce heat dissipation.

Operational failures called faults are displayed on the keypad display as they occur. A comprehensive list of these faults and their meaning is provided in this section. The procedure to access the fault log and diagnostic information is also provided.

Before consulting the factory, check that all power and control wiring is correct and installed per the recommendations given in this manual.

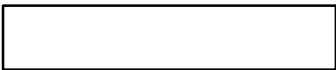
No Keypad Display - Display Contrast Adjustment

At power up, the display could be blank if the contrast is improperly set. The following procedure is used to adjust the display contrast. Be sure keypad is plugged into the keypad connector on the main control board.

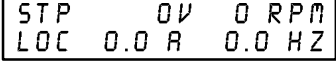
Action	Description	Display
Apply Power	No visible display	
Press DISP Key	Places control in display mode	
Press SHIFT SHIFT	Allows display contrast adjustment	
Press ▲ or ▼ Key	Adjusts display intensity	
Press ENTER	Saves level of contrast and exits to display mode	

Wrong Language Selection

The following procedure is used to set the language used by the keypad display. The table on this page shows the selections in each of the languages.

Action	Description	Display
Apply Power		<pre>STP 0V 0 RPM LOC 0.0 R 0.0 HZ</pre>
Press SHIFT		<pre>STP 0V 0 RPM LOC 0.0 R 0.0 HZ</pre>
Press PROG	Displays selected language.	<pre>LANGUAGE SELECT P: ENGLISH</pre>
Press ENTER	Allows language selection.	<pre>LANGUAGE SELECT △ ENGLISH</pre>
Press ▲ or ▼ Key	Scroll to the desired language.	<pre>LANGUAGE SELECT △ ENGLISH</pre>
Press ENTER	Saves selection and exits to display mode.	<pre>LANGUAGE SELECT P: ENGLISH</pre>

English	Spanish	French	German	Italian	Portuguese
LANGUAGE SELECT	SELECCION IDIOMA	SELECTION LANGUE	SPRACHAUSWAHL	SELEZIONE LINGUA	SELE/ LINGUAGEM
ENGLISH	INGLES	ANGLAIS	ENGLISCH	INGLESE	INGLES
SPANISH	ESPAÑOL	ESPAGNOL	SPANISCH	SPAGNOLO	ESPAÑOL
FRENCH	FRANCAIS	FRANCAIS	FRANZOSISCH	FRANCESE	FRANCAIS
GERMAN	ALEMAN	ALLEMAND	DEUTSCH	TEDESCO	ALEMAO
ITALIAN	ITALIANO	ITALIEN	ITALIENISCH	ITALIANO	ITALIANO
PORTUGUESE	PORTUGUES	PORTUGAIS	PORTUGIESISCH	PORTOGHESE	PORTUGUESES

Diagnostic Information Access

Action	Description	Display
Apply Power	Display of mode & drive status.	<pre>STP 0V 0 RPM LOC 0.0 A 0.0 HZ</pre>
Press DISP key several times	Scroll to Diagnostic Info entry point.	<pre>PRESS ENTER FOR DIAGNOSTIC INFO</pre>
Press ENTER key	Access diagnostic information.	<pre>STOP FREQ REF LOCAL 2.00 HZ</pre>
Press DISP key	Control temperature.	<pre>STOP CONTROL TMP LOCAL 25.0° C</pre>
Press DISP key	Bus voltage.	<pre>STOP BUS VOLTAGE LOCAL 321V</pre>
Press DISP key	PWM Frequency.	<pre>STOP PWM FREQ LOCAL 2500 HZ</pre>
Press DISP key	% overload current remaining.	<pre>STOP OVRLD LEFT LOCAL 100.00%</pre>
Press DISP key	Display of HP, voltage, rated peak & continuous current.	<pre>2.0HP 230V 6.0A 13.6APK</pre>
Press DISP key	Real time opto inputs & relay outputs states. (0=Open, 1=Closed)	<pre>DIGITAL I/O 0000000 0</pre>
Press DISP key	Display of Analog Inputs.	<pre>ANA IN1: 1.1% ANA IN2: 0.03V</pre>
Press DISP key	(Displayed in Process Control mode only) Display of "Proportional", "Integral" and "Derivative" terms.	<pre>PID TERMS 0 0 0</pre>
Press DISP key	(Displayed in Process Control mode only) Display of "Feedforward" (1st line), "Setpoint" and "Feedback" equiv. freq. (2nd line, left to right)	<pre>PROC.CTL 0.00HZ 0.00HZ 0.00HZ</pre>
Press DISP key	Operating time.	<pre>ACCUMULATED TIME 000111:09:45</pre>
Press DISP key	Display of software version.	<pre>USER INT 15JX.XX MOTOR CTL X.XX</pre>
Press DISP key	Displays exit choice. Press ENTER to exit.	<pre>PRESS ENTER FOR DIAGNOSTIC EXIT</pre>

Note: In Diagnostic mode only, press DISP to display next item or press SHIFT to display previous item.

How to Access the Fault Log

When a fault condition occurs, motor operation stops and a fault code is displayed on the Keypad display. The control keeps a log of the last 31 faults. If more than 31 faults have occurred, the oldest fault will be deleted from the fault log. To access the fault log, perform the following procedure:

Action	Description	Display
Apply Power	Display of mode & drive status.	<pre>STP 0V 0 RPM LOC 0.0 A 0.0 HZ</pre>
Press DISP key	Press DISP to scroll to the Fault Log entry point.	<pre>PRESS ENTER FOR FAULT LOG</pre>
Press ENTER key	Display first fault type and time fault occurred.	<pre>EXTERNAL TRIP 1: 00:00:30</pre>
Press ▲ key	Scroll through fault messages.	<pre>PRESS ENTER FOR FAULT LOG EXIT</pre>
Press ENTER key	Scroll to diagnostic info block.	<pre>PRESS ENTER FOR DIAGNOSTIC INFO</pre>
Press RESET key	Return to display mode.	<pre>STP 0V 0 RPM LOC 0.0 A 0.0 HZ</pre>

How to Clear the Fault Log

Use the following procedure to clear the fault log.

Action	Description	Display
Apply Power	Display of mode & drive status.	<pre>STP 0V 0 RPM LOC 0.0 A 0.0 HZ</pre>
Press DISP key several times	Scroll to diagnostic info block.	<pre>PRESS ENTER FOR DIAGNOSTIC INFO</pre>
Press DISP key	Press DISP to scroll to the Fault Log entry point.	<pre>PRESS ENTER FOR FAULT LOG</pre>
Press ENTER key	Displays most recent message.	<pre>EXTERNAL TRIP 1: 00:00:30</pre>
Press SHIFT key		<pre>EXTERNAL TRIP 1: 00:00:30</pre>
Press RESET key		<pre>EXTERNAL TRIP 1: 00:00:30</pre>
Press SHIFT key		<pre>EXTERNAL TRIP 1: 00:00:30</pre>
Press ENTER key	Fault log is cleared.	<pre>FAULT LOG NO FAULTS</pre>

Table 5-1 Fault Messages

FAULT MESSAGE	DESCRIPTION
Invalid Base ID	Failure to determine control horsepower and input voltage configuration from the Power Base ID value in software.
Commun Timeout	Communication failure between interface board and motor control.
2 SEC Overload	* Output current exceeded 3 second rating.
1 MIN Overload	* Output current exceeded 1 minute rating.
CUR LIM Timeout	Peak output current exceeded PK CURRENT LIMIT parameter value.
HW Surge Current	High output current condition detected (greater than 250% of rated output current).
Heat Sink Temp	Control heatsink exceeded upper temperature limit.
Hardware Protect	A general hardware fault was detected but cannot be isolated. Ground Fault detected (output current leakage to ground) or power supply undervoltage.
Regen RES Power	Regen power exceeded dynamic brake resistor rating.
Precharge FLT	DC Bus charging error detected.
Bus Overvoltage	High DC Bus voltage.
Bus Undervoltage	Low DC Bus voltage.
Software VER FLT	Keypad and control software versions are incompatible.
External Trip	Connection between J4-17 and J4-18 is open.
FE EEPROM Error	Non-volatile memory on the keypad has failed.
New Base ID	Control board detected a change in the Power Base ID value in software.

* Note: An overload fault cannot be reset (cleared) until the “% OVERLOAD LEFT” counter reaches 100%.

Table 5-2 Troubleshooting

INDICATION	POSSIBLE CAUSE	CORRECTIVE ACTION
No Display	No input voltage.	Check input power for proper voltage. Adjust display contrast.
Bus Overvoltage	Excessive dynamic braking power.	Check dynamic brake watt and resistance parameter values. Increase the DECEL time. Add external dynamic braking assemblies.
	DECEL Rate value set too low.	Lengthen DECEL time. Add external dynamic braking resistors or module.
	Overhauling Motor load	Correct problem with motor load. Add external dynamic braking resistors or module.
	Dynamic brake wiring problem.	Check dynamic brake hardware wiring.
	Input voltage too high.	Verify proper AC line voltage. Use step down transformer if needed. Use line reactor to minimize spikes.
Bus Undervoltage	Input voltage too low.	Disconnect dynamic brake hardware and repeat operation. Verify proper AC line voltage. Use step up transformer if needed. Check power line disturbances (sags caused by start up of other equipment). Monitor power line fluctuations with date and time imprint to isolate power problem.
Hardware Protect	Output current (motor current) leakage to ground.	Disconnect wiring between control and motor. Turn power OFF then ON (cycle power). Retry test. If Ground Fault is cleared, reconnect motor leads and retry the test. Repair motor if internally shorted. Replace motor lead wire with low capacitance cable. If Ground Fault remains, contact Baldor.
Heatsink Temp	Motor Overloaded.	Correct motor loading. Verify proper sizing of control and motor.
	Ambient temperature too high.	Relocate control to cooler operating area. Add cooling fans or air conditioner to control cabinet.
	Built-in fans are ineffective or inoperative.	Verify fan operation. Remove debris from fan and heatsink surfaces. Replace fan or check fan wiring.
Invalid Base ID	Control does not recognize hp and Voltage configuration.	Turn power OFF then ON (cycle power). If fault remains call Baldor.
New Base ID	Replaced Control or circuit board.	Restore parameters to factory settings. Reset control.
FE EEPROM Error	Non-volatile memory on the keypad has failed.	Press "RESET" key on keypad. Restore factory settings. Reset power. If fault remains, contact Baldor.
Precharge FLT	DC Bus charging error detected.	Turn power OFF then ON (cycle power). If fault remains, contact Baldor.

Table 5-2 Troubleshooting Continued

INDICATION	POSSIBLE CAUSE	CORRECTIVE ACTION
External Trip	Motor ventilation insufficient.	Clean motor air intake and exhaust. Check external blower for operation. Verify motor's internal fan is coupled securely.
	Motor draws excessive current.	Check motor for overloading. Verify proper sizing of control and motor.
	Volts/Hertz ratio is wrong.	Adjust the Volts/Hz parameter value. Adjust the Base Frequency. Adjust the Max Output Voltage.
	No thermostat connected.	Connect thermostat. Verify connection of all external trip circuits used with thermostat. Disable thermostat input at control.
	Poor thermostat connections.	Check thermostat connections.
	External trip parameter incorrect.	Verify connection of external trip circuit at J4-17. Set external trip parameter to "OFF" if no connection made at J4-17.
HW Surge Current	High output current condition detected (greater than 250% of rated output current).	Turn power OFF then ON (cycle power). If error occurred while ramping motor, check motor, coupling and load. Increase Accel time. Increase/Decrease torque boost value. Press "RESET" key on keypad. If fault remains, contact Baldor.
Motor Will Not Start	Not enough starting torque.	Increase Current Limit setting.
	Motor overloaded.	Check for proper motor loading. Check couplings for binding. Verify proper sizing of control and motor.
	Control not in local mode of operation.	Place control in local mode.
	Motor may be commanded to run below minimum frequency setting.	Increase speed command or lower minimum frequency setting.
	Incorrect Command Select parameter.	Change Command Select parameter to match wiring at J4.
	Incorrect frequency command.	Verify control is receiving proper command signal at J4.
CUR LIM Timeout	Peak output current exceeded PK CURRENT LIMIT.	Check PK Current Limit parameter in the Level 2 Output Limits block. Check motor for overloading. Increase ACCEL/DECEL times. Reduce motor load. Verify proper sizing of control and motor.

Table 5-2 Troubleshooting Continued

INDICATION	POSSIBLE CAUSE	CORRECTIVE ACTION
Motor Will Not Reach Maximum Speed	Max Frequency Limit set too low.	Adjust Max Frequency Limit parameter value.
	Motor overloaded.	Check for mechanical overload. If unloaded motor shaft does not rotate freely, check motor bearings.
	Improper speed command.	Verify control is receiving proper command signal at input terminals. Verify control is set to proper operating mode to receive your speed command.
	Speed potentiometer failure.	Replace potentiometer.
Motor will not stop rotation	MIN Output Speed parameter set too high.	Adjust MIN Output Speed parameter value.
	Improper speed command.	Verify control is receiving proper command signal at input terminals. Verify control is set to receive your speed command.
	Speed potentiometer failure.	Replace potentiometer.
Motor runs rough at low speed	Torque boost set too high.	Adjust torque boost parameter value.
	Misalignment of coupling.	Check motor/load coupling alignment.
	Faulty motor.	Replace with a Baldor Motor.
Regen RES Power	Incorrect dynamic brake parameter.	Check Resistor Ohms and Resistor Watts parameters in the Level 2 Brake Adjust block.
	Regen power exceeded resistor rating.	Use resistor with a larger power rating. Increase Decel Time.
Comm Timeout	Communication failure between keypad and motor control.	Verify connections of all signals and grounds. Press "RESET" key on keypad. If fault remains, contact Baldor.
Software VER FLT	Keypad and control software versions are incompatible.	Press "RESET" key on keypad. Reset power. If fault remains, contact Baldor.
3 SEC Overload *	Output current exceeded 3 second rating.	Verify motor rated amperes parameter matches FLA of motor. Verify proper sizing of control and motor. If error occurred while ramping motor, check motor, coupling and load.
1 MIN Overload *	Output current exceeded 1 minute rating.	Increase ACCEL time. Increase/Decrease Torque Boost value.

* Note: An overload fault cannot be reset (cleared) until the "% OVERLOAD LEFT" counter reaches 100%.

Electrical Noise Considerations

All electronic devices are vulnerable to significant electronic interference signals (commonly called “Electrical Noise”). At the lowest level, noise can cause intermittent operating errors or faults. From a circuit standpoint, 5 or 10 millivolts of noise may cause detrimental operation. For example, analog speed inputs are often scaled at 5 to 10VDC maximum with a typical resolution of one part in 1,000. Thus, noise of only 5 mV represents a substantial error.

At the extreme level, significant noise can cause damage to the drive. Therefore, it is advisable to prevent noise generation and to follow wiring practices that prevent noise generated by other devices from reaching sensitive circuits. In a control, such circuits include inputs for speed, control logic, and speed and position feedback, plus outputs to some indicators and computers.

Relay and Contactor Coils

Among the most common sources of noise are the ever-present coils of contactors and relays. When these highly inductive coil circuits are opened, transient conditions often generate spikes of several hundred volts in the control circuit. These spikes can induce several volts of noise in an adjacent wire that runs parallel to a control-circuit wire.

Figure 5-4 illustrates noise suppression for AC and DC operated coils.

Figure 5-4 Diode with DC Coil

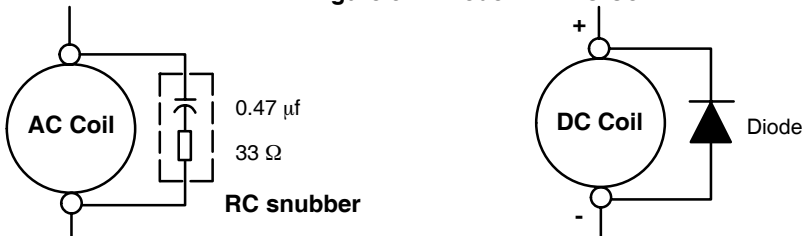

Wires between Controls and Motors

Output leads from a typical 460 VAC drive controller contain rapid voltage rises created by power semiconductors switching 650V in less than a microsecond, 1,000 to 10,000 times a second. These noise signals can couple into sensitive drive circuits. If shielded pair cable is used, the coupling is reduced by nearly 90% compared to unshielded cable.

Even input AC power lines contain noise and can induce noise in adjacent wires. In some cases, line reactors may be required.

To prevent induced transient noise in signal wires, all motor leads and AC power lines should be contained in rigid metal conduit, or flexible conduit. Do not place line conductors and load conductors in same conduit. Use one conduit for 3 phase input wires and another conduit for the motor leads. The conduits should be grounded to form a shield to contain the electrical noise within the conduit path. Signal wires - even ones in shielded cable should never be placed in the conduit with motor power wires.

Special Drive Situations

For severe noise situations, it may be necessary to reduce transient voltages in the wires to the motor by adding load reactors. Load reactors are installed between the control and motor.

Reactors are typically 1% to 3% impedance and are designed for the frequencies encountered in PWM drives. For maximum benefit, the reactors should be mounted in the drive enclosure with short leads between the control and the reactors.

Special Motor Considerations

Motor frames must also be grounded. As with control enclosures, motors should be grounded directly to plant ground with as short a ground wire as possible. Capacitive coupling within the motor windings produces transient voltages between the motor frame and ground. The severity of these voltages increases with the length of the ground wire. Installations with the motor and control mounted on a common frame, and with heavy ground wires less than 10 ft. long, rarely have a problem caused by these motor-generated transient voltages.

Analog Signal Wires

Analog signals generally originate from speed and torque controls, plus DC tachometers and process controllers. Reliability is often improved by the following noise reduction techniques:

- Use twisted-pair shielded wires with the shield grounded at the drive end only.
- Route analog signal wires away from power or control wires (all other wiring types).
- Cross power and control wires at right angles (90°) to minimize inductive noise coupling.

Section 6

Specifications and Product Data

Specifications:

Horsepower	0.33-1HP @ 115VAC 1-3 HP @ 230VAC 1-5 HP @ 460VAC
Input Frequency	50/60Hz \pm 5%
Input Impedance	1%
Output Voltage	0 to Maximum Input VAC
Output Current	See Ratings Table
Output Frequency	0 to 120Hz
Service Factor	1.0
Duty	Continuous
Overload Capacity	Constant Torque Mode: 200% for 2 seconds 150% for 60 seconds
Frequency Setting	Keypad, 0-5VDC, 0-10VDC, 4-20mA, 0-20mA
Frequency Setting Potentiometer	5k Ω or 10k Ω , 1/2 Watt
Rated Storage Temperature:	- 30°C to +65°C

Operating Conditions:

Voltage Range:	
115 VAC Models	90-132 VAC 1 ϕ 60/50Hz
230 VAC Models	180-264 VAC 3 ϕ 60Hz/50Hz
460 VAC Models	340-528 VAC 3 ϕ 60Hz/50Hz
Input Line Impedance:	1% Minimum Required
Ambient Operating Temperature:	0 to +40°C Derate Output 2% per °C over 40°C to 55°C (130°F) Maximum
Enclosure:	NEMA 1: ER (suffix) Models
Humidity:	NEMA 1: To 90% RH non-condensing
Altitude:	Sea level to 3300 feet (1000 meters) Derate 2% per 1000 feet (303 meters) above 3300 feet
Shock:	1G
Vibration:	0.5G at 10Hz to 60Hz

Keypad Display:

Display	Backlit LCD Alphanumeric 2 Lines x 16 Characters
Keys	Membrane keypad with tactile response
Functions	Output status monitoring Digital speed control Parameter setting and display Fault log display Motor run and jog Local/Remote
LED Indicators	Forward run command Reverse run command Stop command Jog active
Optional Remote Mount Keypad	100 feet Maximum from control

Control Specifications:

Control Method	Sine wave carrier input, PWM output
Frequency Accuracy	0.01Hz Digital 0.05 % Analog
Frequency Resolution	0.01Hz Digital 0.5% Analog
Carrier Frequency	2.5, 5.0 and 7.5kHz
Transistor Type	IGBT (Insulated Gate Bipolar Transistor)
Transistor Rise Time	2500 V/ μ sec. (dv/dt)
Torque Boost	Automatic adjustment to load (Standard) 0 to 15% of input voltage (Manual)
Volts/Hertz Pattern	Linear, Squared Reduced, Three Point
Accel/Decel Time	0 to 600 sec. for 2 assignable plus JOG
S-Curve Time	0 to 100%
Base Frequency	10 to 120Hz
Regenerative Braking Torque	50% with optional external braking resistor (-ER)
Jog Frequency	0 to Maximum frequency
Skip Frequency	0 to Maximum frequency in 3 zones.
Minimum Output Frequency	0 to 150Hz
Maximum Output Frequency	0 to 150Hz
Auto Restart	Manual or Automatic
Slip Compensation	0 to 6Hz
Operating modes	Keypad Standard Run 7 Speed Fan Pump 2Wire Fan Pump 3Wire Process Control 3SPD ANA 2WIRE 3SPD ANA 3WIRE EPOT - 2WIRE EPOT - 3WIRE

Analog Inputs: (2 Inputs)

Potentiometer Input	0 - 10VDC
Differential Input Full Scale Range	0-5VDC, 0-10VDC, 4-20mA, 0-20mA
Differential Input Common Mode Rejection	40db
Input Impedance	20k Ω

Analog Output: (1 Output)

Analog Outputs	1 Assignable
Full Scale Range	0-5 VDC, 0-10 VDC, 4-20mA, 0-20mA
Resolution	8 bits
Output Conditions	10 conditions plus calibration (see parameter table)

Digital Inputs: (7 Inputs)

Digital Inputs	7 Assignable
Input Impedance	6.8k Ω (Closed contacts standard)
Leakage Current	10 μ A Maximum

Digital Outputs: (1 Output)

Relay Output (N.O. and N.C.)	1 Assignable
Rated Voltage	230VAC
Maximum Current	5A Maximum (non-inductive)
Output Conditions	11 Conditions (see parameter table)

Fault Indications:

INVALID BASE ID	BUS OVERVOLTAGE
NEW BASE ID	BUS UNDERVOLTAGE
1 MIN OVERLOAD	HEAT SINK TEMP
2 SEC OVERLOAD	EXTERNAL TRIP
CURRENT TIMEOUT	REGEN RES POWER
PRECHARGE FLT	SOFTWARE VER FLT
HW GROUND FAULT	FE EEPROM ERROR
HW SURGE CURRENT	
HARDWARE PROTECT	

Note: All specifications are subject to change without notice.

Ratings: Series 15J Stock Products

Catalog No.	Rated Input Volts	Rated Output Volts	HP	kW	Output Current		
					Continu-ous	60 Sec. Overload	2 Sec. Overload
ID15J1F33-ER	115	230	0.33	0.25	1.6	2.4	3.2
ID15J1F50-ER	115	230	0.5	0.37	2.2	3.3	4.4
ID15J1F75-ER	115	230	0.75	0.56	3.2	4.8	6.4
ID15J101-ER	115	230	1.0	0.75	4.2	6.3	8.4
ID15J201-ER	230	230	1	0.75	4.2	6.3	8.4
ID15J201F5-ER	230	230	1.5	1.1	6.0	9.0	12.0
ID15J202-ER	230	230	2	1.5	6.8	10.2	13.4
ID15J203-ER	230	230	3	2.2	9.6	14.4	19.2
ID15J205-ER	230	230	5	3.7	15.2	22.8	30.4
ID15J401-ER	460	460	1	0.75	2.1	3.2	4.2
ID15J401F5-ER	460	460	1.5	1.1	3.0	4.5	6.0
ID15J402-ER	460	460	2	1.5	3.4	5.1	6.8
ID15J403-ER	460	460	3	2.2	4.8	7.2	9.6
ID15J405-ER	460	460	5	3.7	7.6	11.4	15.2
ID15J407-ER	460	460	7.5	5.6	11.0	16.5	22.0
ID15J410V-ER	460	460	10.0	7.6	14.0	16.1	16.1

Terminal Tightening Torque Specifications:

Table 6-3 Torques for “ER”

Control Voltage Rating VAC	Tightening Torque			
	Control Terminals (J4)		Power Terminals (J5)	
	Lb-in	Nm	Lb-in	Nm
115, 230 and 460	4	0.45	7	0.8

Mounting Dimensions

inches (mm)

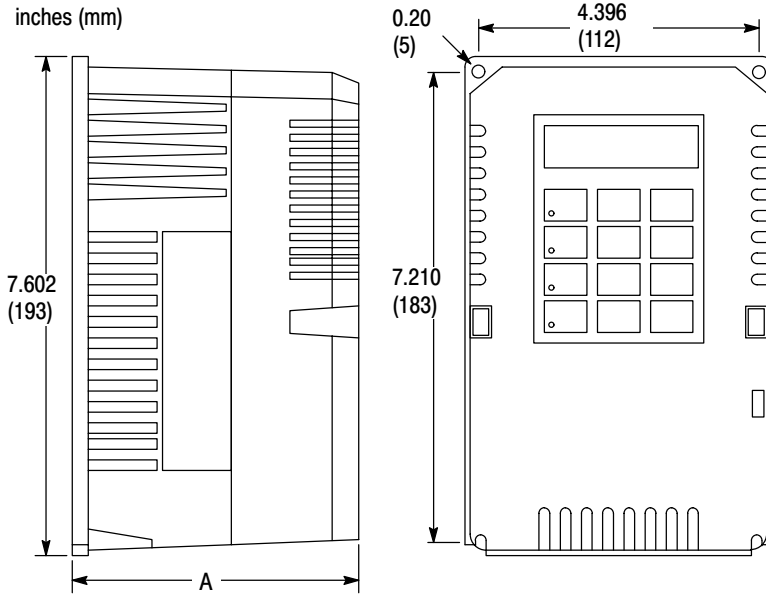

A = 5.235 (133) for 230VAC, 5hp and 460VAC, 7.5 & 10hp.
 A = 4.485 (114) for all other sizes.

B = 4.886 (124) for 230VAC, 5hp and 460VAC, 7.5 & 10hp..
 B = 4.834 (123) for all other sizes.

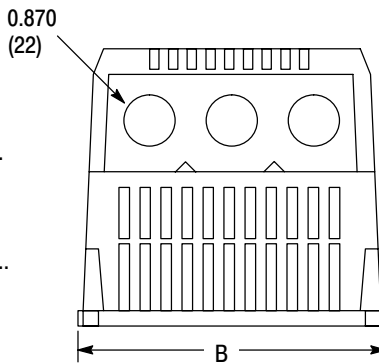

OM0001A02
 OM0001A12

Appendix A

Dynamic Brake Hardware

Dynamic Braking (DB) Hardware

Whenever a motor is abruptly stopped or forced to slow down quicker than if allowed to coast to a stop, the motor becomes a generator. This energy appears on the DC Bus and must be dissipated using dynamic braking hardware. Dynamic braking (DB) hardware is a resistive load. Table A-1 provides a matrix of DB turn ON and turn OFF voltages.

Table A-1

Parameter Description	Control Input Voltage		
	115VAC	230VAC	460VAC
Nominal Voltage	115VAC	230VAC	460VAC
Overvoltage Fault (Voltage exceeded)	400VDC	400VDC	800VDC
DB ON Voltage	381VDC	381VDC	762VDC
DB Upper Tolerance Peak	388VDC	388VDC	776VDC
DB OFF Voltage	375VDC	375VDC	750VDC

Braking torque and time should not exceed the available drive braking torque and time rating. The drive braking torque is limited to the available peak current and peak current time rating of the control. If the peak current or peak current time limit is exceeded during braking, the control may trip on an over voltage or a regen power fault.

Selection Procedure

1. Calculate the watts to be dissipated using the following formulas for the appropriate load type.
2. Identify the control model number and determine which braking hardware is required based on the model number suffix: ER.
3. Select appropriate braking hardware from Baldor 501 Catalog or Table A-2.

Hoisting Load Calculations

1. Calculate braking duty cycle:

$$\text{Duty Cycle} = \frac{\text{Lowering Time}}{\text{Total Cycle Time}}$$

2. Calculate braking watts to be dissipated in dynamic braking resistors:

$$\text{Watts} = \frac{\text{duty cycle} \times \text{lbs} \times \text{FPM} \times \text{efficiency}}{44}$$

where: lbs = weight of load
 FPM = Feet Per Minute
 efficiency = mechanical efficiency
 i.e., 95% = 0.95

Dynamic Braking (DB) Hardware Continued

General Machinery Load Calculations:

1. Calculate braking duty cycle:

$$\text{Duty Cycle} = \frac{\text{Braking Time}}{\text{Total Cycle Time}}$$

2. Calculate deceleration torque:

$$T_{\text{Decel}} = \frac{\text{RPM change} \times Wk^2}{308 \times \text{time}} - \text{Friction}_{(\text{Lb}-\text{Ft})}$$

where: T_{Decel} = Deceleration torque in lb-ft
 Wk^2 = Inertia in lb-ft²
time = In seconds

3. Calculate watts to be dissipated in dynamic braking resistor:

$$\text{Watts} = T_{\text{Decel}} \times (S_{\text{max}} - S_{\text{min}}) \times \text{Duty Cycle} \times (0.0712)$$

where: S_{max} = Speed to start braking
 S_{min} = Speed after braking

4. Multiply watts calculated in step 3 by 1.25 to allow for unanticipated loads (safety factor).

15J Catalog Numbers with an "ER" Suffix

These controls include a factory-installed dynamic braking transistor. If dynamic braking is required, use an optional external RGA brake resistor. See RGA assemblies.

RGA Assemblies include braking resistors completely assembled and mounted in a NEMA 1 enclosure. A listing of available RGA assemblies is provided in Table A-2. The minimum resistance "Minimum Ohms" shown in the table is the minimum resistor value that can be connected to the control without causing damage to the internal dynamic brake transistor for ER controls.

115VAC controls must use 56 ohms or greater.

230VAC controls must use 56 ohms or greater.

460VAC controls must use 120 ohms or greater.

Table A-2 Dynamic Braking Resistor Assemblies (RGA)

Continuous Rated Watts	Minimum Ohms			
	30	60	120	150
100		RGJ160	RGJ1120	RGJ1150
200		RGJ260	RGJ2120	RGJ2150
300		RGJ360	RGJ3120	RGJ3150
600	RGA630	RGA660	RGA6120	
1200	RGA1230	RGA1260	RGA12120	
2400	RGA2430	RGA2460	RGA24120	
4800	RGA4830	RGA4860		

Dynamic Braking (DB) Hardware Continued
Table A-3 Dynamic Braking Resistor Assemblies (RGJ)

HP	Input Volts	Min Ohms	Continuous Watts		
			100	200	300
0.33 – 7.5	115 / 230	60	RGJ160	RGJ260	RGJ360
2 – 10	460	120	RGJ1120	RGJ2120	RGJ3120
1.0 – 1.5	460	150	RGJ1150	RGJ2150	RGJ3150

Figure A-5 100–300 Watts

IRV 60~150: a=10, b=12 standard

IRV200~500: a=13, b=17 standard

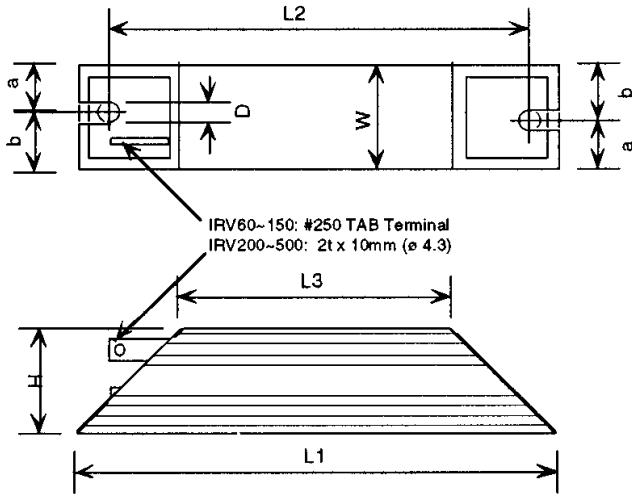

Appendix B

Parameter Values

Parameter Values (Interface Version 2.01) Level 1

PRESET SPEEDS Block

Parameter	Adjustable Range	Factory Setting	User Setting
PRESET SPEED #1	0-Max Output Freq	0.00Hz	
PRESET SPEED #2	0-Max Output Freq	0.00Hz	
PRESET SPEED #3	0-Max Output Freq	0.00Hz	
PRESET SPEED #4	0-Max Output Freq	0.00Hz	
PRESET SPEED #5	0-Max Output Freq	0.00Hz	
PRESET SPEED #6	0-Max Output Freq	0.00Hz	
PRESET SPEED #7	0-Max Output Freq	0.00Hz	

ACCEL/DECEL RATE Block

Parameter	Adjustable Range	Factory Setting	User Setting
ACCEL TIME #1	000.1 to 600.0 Seconds	10.0S	
DECEL TIME #1	000.1 to 600.0 Seconds	10.0S	
S-CURVE #1	0 to 100%	0%	
ACCEL TIME #2	000.1 to 600.0 Seconds	20.0S	
DECEL TIME #2	000.1 to 600.0 Seconds	20.0S	
S-CURVE #2	0 to 100%	0%	

JOG SETTINGS Block

Parameter	Adjustable Range	Factory Setting	User Setting
JOG SPEED	0-Max Output Freq	7.00Hz	
JOG ACCEL TIME	000.1-600.0 Seconds	3.0S	
JOG DECEL TIME	000.1-600.0 Seconds	3.0S	
JOG S-CURVE	0-100%	0%	

Parameter Values Level 1 Continued

INPUT Block

Parameter	Adjustable Range	Factory Setting	User Setting
OPERATING MODE	Keypad Standard Run 7 Speed Fan Pump 2Wire Fan Pump 3Wire Process Control 3SPD ANA 2WIRE 3SPD ANA 3WIRE EPOT 2WIRE EPOT 3 WIRE	Keypad	
ANA CMD SELECT	Potentiometer 0-10 Volts 0-5 Volts 4 TO 20 mA 0 TO 20 mA None	Potentiometer	
ANA CMD INVERSE	OFF, ON	OFF	
ANA CMD OFFSET	-20.0 to +20.0%	0.0%	
ANA CMD GAIN	80.0% to 120%	100.0%	
ANA CMD FILTER	0-6	1	

OUTPUT Block

Parameter	Adjustable Range	Factory Setting	User Setting
RELAY OUTPUT	Ready Zero Speed At Speed Band At Set Speed Overload Underload Keypad Control Fault Drive On Reverse Process Error	Ready	
ZERO SPD SET PT	0-Max Output Freq	6.00Hz	
AT SPEED BAND	0-20.00Hz	20.00Hz	
SET SPEED POINT	0-Max Output Freq	60.00Hz	
OVERLOAD SET PT	0-PK Current Limit	Factory Set	
UNDERLOAD SET PT	0-PK Current Limit	Factory Set	
ANALOG OUT TYPE	0-10 VOLTS, 0-5 VOLTS, 4TO20mA, 0TO20mA	0-10 VOLTS	

Parameter Values Level 1 Continued**OUTPUT Block** Continued

Parameter	Adjustable Range	Factory Setting	User Setting
ANALOG OUT	Frequency Freq Command AC Current AC Voltage Bus Voltage Control Temp Process Feedback Set Point Command Zero CAL 100% CAL	Frequency	
ANALOG SCALE	10-160%	100%	

KEYPAD SETUP Block

Parameter	Adjustable Range	Factory Setting	User Setting
KEYPAD STOP KEY	Remote ON, Remote OFF	Remote ON	
KEYPAD STOP MODE	Regen Braking Coast-No Regen	Regen Braking	
KEYPAD RUN FWD	OFF, ON	ON	
KEYPAD RUN REV	OFF, ON	ON	
KEYPAD JOG FWD	OFF, ON	ON	
KEYPAD JOG REV	OFF, ON	ON	
SWITCH ON FLY	OFF, ON	OFF	
LOC. HOT START	OFF, ON	OFF	

V/Hz AND BOOST Block

Parameter	Adjustable Range	Factory Setting	User Setting
CTRL BASE FREQUENCY	50.00-120.00Hz	60.00Hz	
TORQUE BOOST	00.0 - 15.0%	Factory Set	
SLIP COMP ADJ	0.00 - 6.00Hz	0.00Hz	
V/Hz PROFILE	0-100% 0%=Linear Profile	0%	
3-PT OPERATION	OFF, ON	OFF	
3-PT VOLTS	000.0-100.0%	0.0%	
3-PT FREQUENCY	000.0-Ctrl Base Freq. (150Hz max)	0.00Hz	
MAX OUTPUT VOLTS	0-460 (for 460 volt units) 0-230 (for 230 volt units) 0-230 (for 115 volt units)	Factory Set	

Parameter Values Level 2

OUTPUT LIMITS Block

Parameter	Adjustable Range	Factory Setting	User Setting
MIN OUTPUT FREQ	000.0-Max Output Freq	0.00Hz	
MAX OUTPUT FREQ	000.0-120.00	60.00Hz	
PK CURRENT LIMIT	00.0-Peak Rated Current	Factory Set	
PWM FREQUENCY	2.5, 5.0, 7.5 kHz	Factory Set	

PROTECTION Block

Parameter	Adjustable Range	Factory Setting	User Setting
EXTERNAL TRIP	OFF, ON	OFF	
FOLDBACK PROTECT	OFF, ON	OFF	

MISCELLANEOUS Block

Parameter	Adjustable Range	Factory Setting	User Setting
RESTART AUTO/MAN	Automatic, Manual	MANUAL	
RESTART FAULT/HR	00-10	0	
RESTART DELAY	000-120 Seconds	0S	
LANGUAGE SELECT	English, Spanish, French, German, Italian, Portuguese	ENGLISH	
FACTORY SETTING	NO, YES	NO	

SECURITY CONTROL Block

Parameter	Adjustable Range	Factory Setting	User Setting
SECURITY STATE	OFF, Local Security	OFF	
ACCESS TIMEOUT	0-600 Seconds	0 S	
ACCESS CODE	0-9999	9999	

MOTOR DATA Block

Parameter	Adjustable Range	Factory Setting	User Setting
MOTOR RATED AMPS	00.0-Max. Amps	Factory Set	
MOTOR RATED SPD	0-10800RPM	1785RPM	
MOTOR RATED FREQ	050.00-120.00Hz	60.00Hz	

Parameter Values Level 2 Continued
BRAKE ADJUST Block

Parameter	Adjustable Range	Factory Setting	User Setting
RESISTOR OHMS	020.0-999.9 OHMS	Factory Set	
RESISTOR WATTS	0-60000 Watts	0	
DC BRAKE VOLTAGE	00.0-15.0	5.0%	
DC BRAKE FREQ	000.00-Max Output Freq	6.00Hz	
BRAKE ON STOP	OFF, ON	OFF	
BRAKE ON REVERSE	OFF, ON	OFF	
STOP BRAKE TIME	00.0-60.0 Seconds	3.0S	
BRAKE ON START	OFF, ON	OFF	
START BRAKE TIME	00.0-60.0 Seconds	3.0S	

PROCESS CONTROL Block

Parameter	Adjustable Range	Factory Setting	User Setting
PROCESS FEEDBACK	0-10 Volts 0-5 Volts 4TO20 mA 0TO20 mA None Potentiometer	0-10 Volts	
PROCESS INVERSE	OFF, ON	OFF	
SETPOINT SOURCE	Set PT Command Potentiometer 0-10 Volts 0-5 Volts 4 TO 20 mA 0 TO 20 mA None	Set PT Command	
SETPOINT COMMAND	0-100.0%	50.0%	
SET PT ADJ LIMIT	0-100.0%	100.0%	
AT SETPOINT BAND	0-100%	10%	
PROCESS PROP GAIN	0-999	500	
PROCESS INT GAIN	0-99.99	0.50	
PROCESS DIFF GAIN	0-9999	0	

SKIP FREQUENCY Block

Parameter	Adjustable Range	Factory Setting	User Setting
SKIP FREQ #1	0–Max Output Freq	0.00Hz	
SKIP BAND #1	0–50.00Hz	0.00Hz	
SKIP FREQ #2	0–Max Output Freq	0.00Hz	
SKIP BAND #2	0–50.00Hz	0.00Hz	
SKIP FREQ #3	0–Max Output Freq	0.00Hz	
SKIP BAND #3	0–50.00Hz	0.00Hz	

SYNCHRO STARTS Block

Parameter	Adjustable Range	Factory Setting	User Setting
Sync STRT Enable	OFF, ON	OFF	
Sync Scan V/F	5.0-100.0%	10.0%	
Sync Setup Time	0.2-2.0 Seconds	1.0S	
Sync Scan Time	01.0-10.0 Seconds	2.0S	

Appendix C

Remote Keypad Mounting Template

Remote Keypad Mounting Template

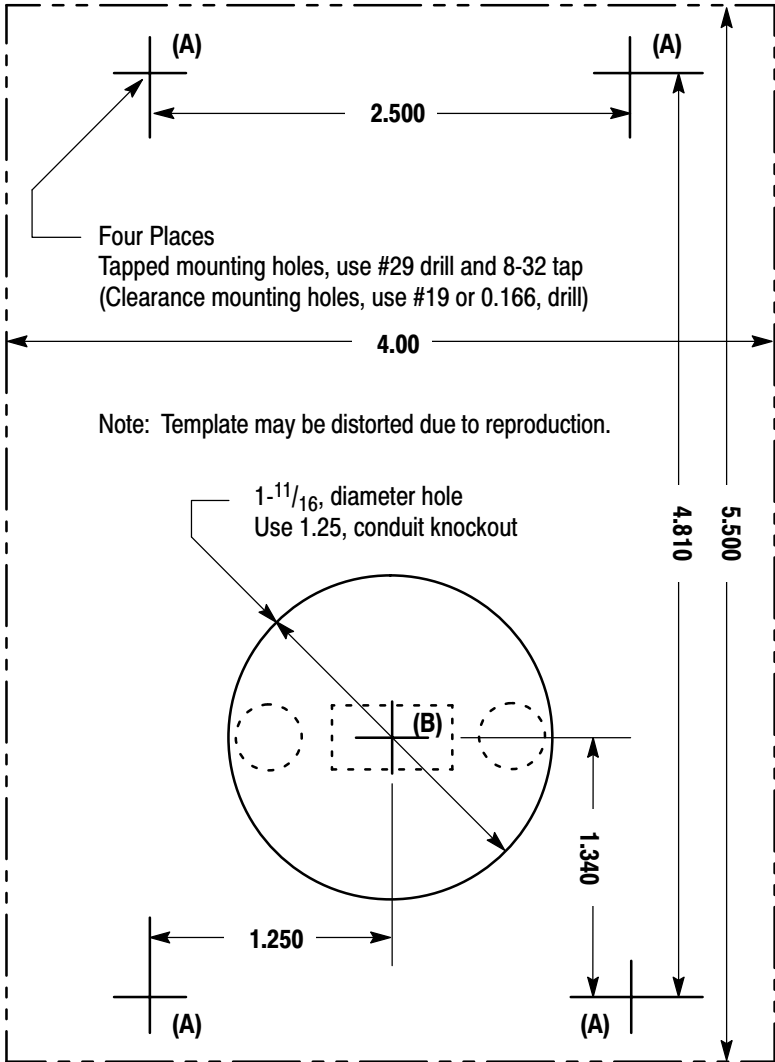

**Baldor District Offices
UNITED STATES**

ARIZONA
PHOENIX
4211 S 43RD PLACE
PHOENIX, AZ 85040
PHONE: 602-470-0407
FAX: 602-470-0464

CALIFORNIA
LOS ANGELES
6480 FLOTILLA
COMMERCE, CA 90040
PHONE: 323-724-6771
FAX: 323-721-5859

HAYWARD
21056 FORBES STREET
HAYWARD, CA 94545
PHONE: 510-785-9900
FAX: 510-785-9910

COLORADO
DENVER
2520 W BARBERY PLACE
DENVER, CO 80204
PHONE: 303-623-0127
FAX: 303-595-3772

CONNECTICUT
WALLINGFORD
65 SOUTH TURNPIKE ROAD
WALLINGFORD, CT 06492
PHONE: 203-269-1354
FAX: 203-269-5485

FLORIDA
TAMPA/PUERTO RICO/
VIRGIN ISLANDS
3906 EAST 11TH AVENUE
TAMPA, FL 33605
PHONE: 813-248-5078
FAX: 813-247-2984

GEORGIA
ATLANTA
62 TECHNOLOGY DR.
ALPHARETTA, GA 30005
PHONE: 770-772-7000
FAX: 770-772-7200

ILLINOIS
CHICAGO
1601 FRONTENAC ROAD
NAPERVILLE, IL 60563
PHONE: 630-848-5100
FAX: 630-848-5110

INDIANA
INDIANAPOLIS
5525 W. MINNESOTA ST.
INDIANAPOLIS, IN 46241
PHONE: 317-246-5100
FAX: 317-246-5100
800-428-4141

IOWA
DES MOINES
1901 BELL AVE., SUITE 7
DES MOINES, IA 50315
PHONE: 515-244-9996
FAX: 515-244-6124

MARYLAND
BALTIMORE
6660 SANTA BARBARA RD
SUITE 22-24
ELKRIDGE, MD. 21075
PHONE: 410-579-2135
FAX: 410-579-2677

MASSACHUSETTS
BOSTON
6 PULLMAN STREET
WORCESTER, MA 01606
PHONE: 508-854-0708
FAX: 508-854-0291

MICHIGAN
DETROIT
33782 STERLING PONDS BLVD.
STERLING HEIGHTS, MI 48312
PHONE: 586-978-9800
FAX: 586-978-9969

GRAND RAPIDS
668 3 MILE ROAD NW
GRAND RAPIDS, MI 49504
PHONE: 616-785-1784
FAX: 616-785-1788

MINNESOTA
MINNEAPOLIS
21080 134TH AVE. NORTH
ROGERS, MN 55374
PHONE: 763-428-3633
FAX: 763-428-4551

MISSOURI
ST LOUIS
422 INDUSTRIAL DRIVE
MARYLAND HEIGHTS, MO 63043
PHONE: 314-298-1800
FAX: 314-298-7660

KANSAS CITY
915 N W PLATTE VALLEY DR
RIVERSIDE, MO 64150
PHONE: 816-587-0272
FAX: 816-587-3735

NEW YORK
AUBURN
ONE ELLIS DRIVE
AUBURN, NY 13021
PHONE: 315-255-3403
FAX: 315-253-9923

NORTH CAROLINA
GREENSBORO
1220 ROTHERWOOD ROAD
GREENSBORO, NC 27406
P O BOX 16500
GREENSBORO, NC 27416
PHONE: 336-272-6104
FAX: 336-273-6628

OHIO
CINCINNATI
2929 CRESCENTVILLE ROAD
CINCINNATI, OH 45069
PHONE: 513-771-2600
FAX: 513-772-2219

CLEVELAND
8929 FREEWAY DRIVE
MACEDONIA, OH 44056
PHONE: 330-468-4777
FAX: 330-468-4778

OKLAHOMA
TULSA
2 EAST DAWES
BIXBY, OK 74008
PHONE: 918-366-9320
FAX: 918-366-9338

OREGON
PORTLAND
20393 SW AVERY COURT
TUALATIN, OR 97062
PHONE: 503-691-9010
FAX: 503-691-9012

PENNSYLVANIA
PHILADELPHIA
1035 THOMAS BUSCH
MEMORIAL HIGHWAY
PENNSAUKEN, NJ 08110
PHONE: 856-661-1442
FAX: 856-663-6363

PITTSBURGH
616H BEATTY ROAD
MONROEVILLE, PA 15146
PHONE: 412-380-7244
FAX: 412-380-7250

TENNESSEE
MEMPHIS
4000 WINCHESTER ROAD
MEMPHIS, TN 38118
PHONE: 901-365-2020
FAX: 901-365-3914

TEXAS
HOUSTON
4647 PINE TIMBERS
SUITE # 105
HOUSTON, TX 77041
PHONE: 713-895-7062
FAX: 713-690-4540

DALLAS
3040 QUEBEC
DALLAS, TX 75247
PHONE: 214-634-7271
FAX: 214-634-8874

UTAH
SALT LAKE CITY
2230 SOUTH MAIN STREET
SALT LAKE CITY, UT 84115
PHONE: 801-832-0127
FAX: 801-832-8911

WISCONSIN
MILWAUKEE
2725 SOUTH 163RD STREET
NEW BERLIN, WI 53151
PHONE: 262-784-5940
FAX: 262-784-1215

INTERNATIONAL SALES
FORT SMITH, AR
BALDOR ELECTRIC CO
FORT SMITH, AR 72902
PHONE: 479-646-4711
FAX: 479-648-5895

CANADA
EDMONTON, ALBERTA
4053-92 STREET
EDMONTON, ALBERTA T6E6R8
PHONE: 780-434-4900
FAX: 780-438-2600

OAKVILLE, ONTARIO
2750 COVENTRY ROAD
OAKVILLE, ONTARIO L6H6R1
PHONE: 905-829-3301
FAX: 905-829-3302

MONTREAL, QUEBEC
1844 WILLIAM STREET
MONTREAL, QUEBEC H3J1R5
PHONE: 514-933-2711
FAX: 514-933-8639

VANCOUVER,
BRITISH COLUMBIA
1538 KEBET WAY
PORT COQUITLAM, BC V3C 5M5
PHONE: 604-421-2822
FAX: 604-421-3113

WINNIPEG, MANITOBA
54 PRINCESS STREET
WINNIPEG, MANITOBA R3B1K2
PHONE: 204-942-5205
FAX: 204-956-4251

AUSTRALIA
UNIT 3, 6 STANTON ROAD
SEVEN HILLS, NSW 2147,
AUSTRALIA
PHONE: (61) (2) 9674 5455
FAX: (61) (2) 9674 2495

UNIT 8, 5 KELLETTS ROAD
ROWVILLE, VICTORIA, 3178
AUSTRALIA
PHONE: (03) 9753 4355
FAX: (03) 9753 4366

BALDOR CENTROAMERICA
BALDOR CENTROAMERICA
RESIDENCIAL PINARES DE SUIZA
POL. 15 #44, NVA. SAN SALVADOR
EL SALVADOR, CENTRO AMERICA
PHONE: (503) 288-1519
FAX: (503) 288-1518

PANAMA
BALDOR SUDAMERICA
9109 0818, ZONA 6 BETHANIA
PANAMA CITY, REP. DE PANAMA
PHONE: (507) 261-5347
FAX: (507) 261-5355

CHINA
SHANGHAI JIAHUA BUSINESS
CENTER
ROOM NO. C-203
808 HONG QIAO ROAD
SHANGHAI 200021
PHONE: 86-21-64473060
FAX: 86-21-64078620

GERMANY
DIESELSTRASSE 22
D-85551 KIRCHHEIM
MUNICH, GERMANY
PHONE: (49) (89) 90508 - 0
FAX: (49) (89) 90508 - 491

ITALY
Baldor ASR AG
Mendrisio Office
Via Borromini, 20A
6850 Mendrisio
Switzerland
PHONE: 0041 91 640 99 50
FAX: 0041 91 630 26 33

JAPAN
DIABLDG 8002,
2-1-1 TSURUYA-CHO,
KANAGAWA-KU
YOKOHAMA, 221-0835, JAPAN
PHONE: 81-45-412-4506
FAX: 81-45-412-4507

KOREA
ROOM 210
BUPYEONG INDUSTRIAL
COMMERCIAL COOP.
396-13 CHEONGCHEON 2-DONG,
BUPYEONG-GU
INCHEON, KOREA, 403-858
PHONE: 82-32-508-3252
FAX: 82-32-508-3253

MÉXICO
BLVD. AL AEROPUERTO, KM. 2
LEON 37545, GUANAJUATO,
MÉXICO
PHONE: 52-477-761-2030
FAX: 52-477-761-2010

SINGAPORE
51 KAKI BUKIT ROAD 2
K B WAREHOUSE COMPLEX
SINGAPORE 417863
PHONE: (65) 6 744 2572
FAX: (65) 6 747 1708

SWITZERLAND
POSTFACH 73
SCHUTZENSTRASSE 59
CH-8245 FEUERTHALEN
SWITZERLAND
PHONE: (41) (52) 6474700
FAX: (41) (52) 6592394

TAIWAN
ROOM R, 2F, NO. 124
CHUNG CHENG ROAD, SHIHLIN
DIST.
TAIPEI 11141
PHONE: 886-2-2835-1666 EXT. 802
FAX: 886-2-2835-1717

UNITED KINGDOM
6 BRISTOL DISTRIBUTION PARK
HAWKLEY DRIVE
BRISTOL BS32 0BF, U.K.
PHONE: 44 1454 850000
FAX: 44 1454 859001



BALDOR ELECTRIC COMPANY
P.O. Box 2400
Fort Smith, AR 72902-2400
(479) 646-4711
Fax (479) 648-5792

CH TEL: +41 52 647 4700 FAX: +41 52 659 2394	D TEL: +49 89 90 50 80 FAX: +49 89 90 50 8491	UK TEL: +44 1454 850000 FAX: +44 1454 859001	F TEL: +33 145 10 7902 FAX: +33 145 09 0864
I TEL: +39 11 562 4440 FAX: +39 11 562 5660	AU TEL: +61 29674 5455 FAX: +61 29674 2495	CC TEL: +65 744 2572 FAX: +65 747 1708	MX TEL: +52 477 761 2030 FAX: +52 477 761 2010