



Allen-Bradley

***Bulletin 1336 FORCE
Adjustable Frequency
AC Drive
Series B, C, D***

***A020 – A030
B040 – B050
BX040, BX060
C025 – C060***

Service Manual

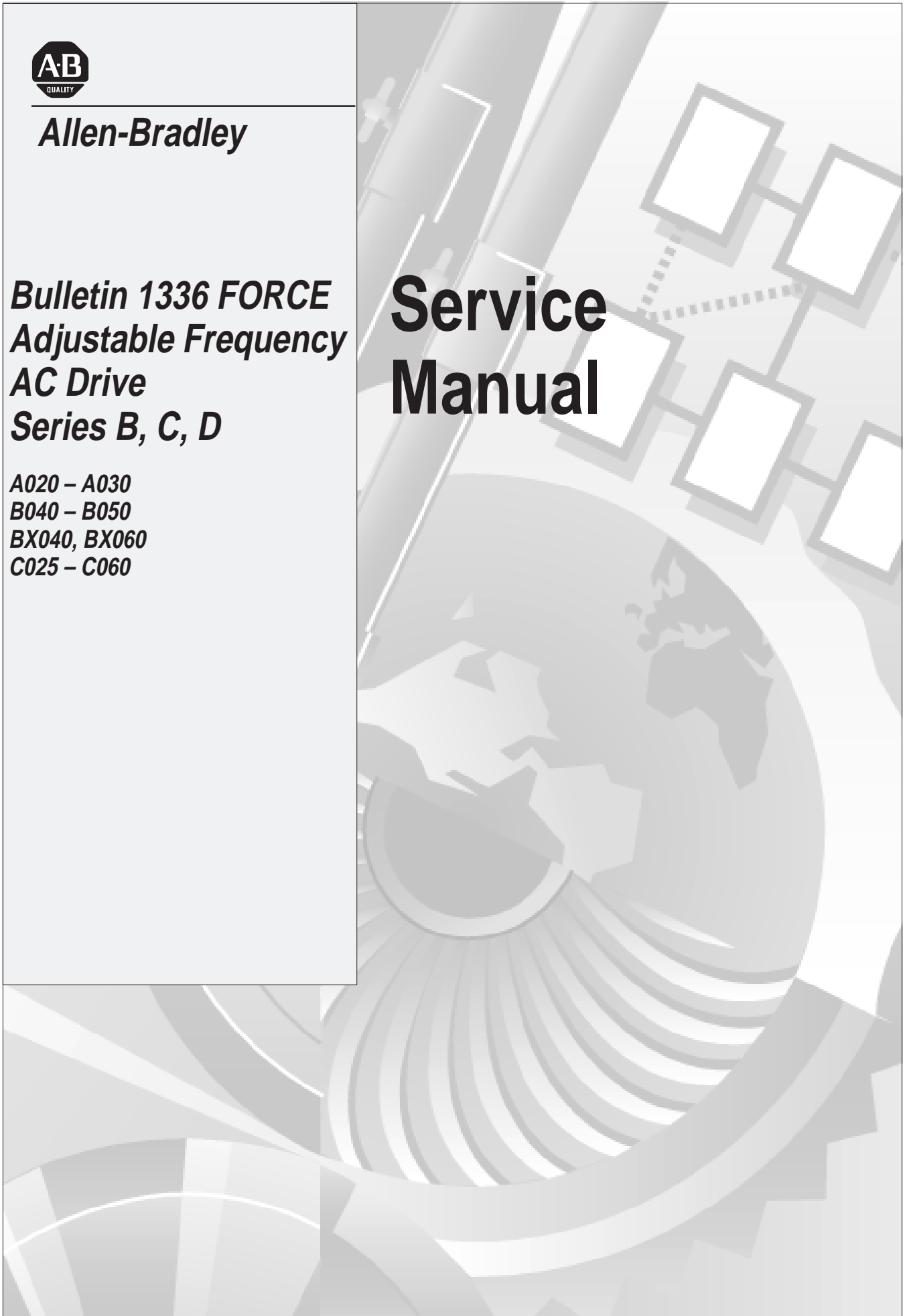

Important User Information

Because of the variety of uses for the products described in this publication, those responsible for the application and use of this control equipment must satisfy themselves that all necessary steps have been taken to assure that each application and use meets all performance and safety requirements, including any applicable laws, regulations, codes and standards.

The illustrations, charts, sample programs and layout examples shown in this guide are intended solely for purposes of example. Since there are many variables and requirements associated with any particular installation, Allen-Bradley does not assume responsibility or liability (to include intellectual property liability) for actual use based upon the examples shown in this publication.

Allen-Bradley publication SGI-1.1, *Safety Guidelines for the Application, Installation, and Maintenance of Solid-State Control* (available from your local Allen-Bradley office), describes some important differences between solid-state equipment and electromechanical devices that should be taken into consideration when applying products such as those described in this publication.

Reproduction of the contents of this copyrighted publication, in whole or in part, without written permission of Allen-Bradley Company, Inc., is prohibited.

Throughout this manual we use notes to make you aware of safety considerations:



ATTENTION: Identifies information about practices or circumstances that can lead to personal injury or death, property damage or economic loss.

Attention statements help you to:

- identify a hazard
- avoid the hazard
- recognize the consequences

Important: Identifies information that is critical for successful application and understanding of the product.

Summary of Changes

The information below summarizes the changes to the company-wide templates since the last release.

Updated Information

The derating tables in the Preface have been removed. Refer to the 1336 FORCE User Manual.

This Page Intentionally Left Blank

Preface

| | |
|---|-----|
| Manual Objective | P-1 |
| Who Should Use This Manual | P-1 |
| Safety Precautions | P-1 |
| Electrostatic Discharge Precautions | P-2 |
| 1336 FORCE Product Identification | P-3 |
| Drive Nameplate Location | P-3 |
| Software Compatibility | P-3 |
| Drive and Option Identification | P-4 |
| 1336 FORCE Drive Catalog Numbers | P-4 |
| Drive Rating Qualifications | P-6 |
| Enclosure Type | P-7 |
| Conventions | P-7 |
| Auxiliary Input | P-7 |
| Auxiliary Interlock | P-7 |
| Bit | P-7 |
| Check | P-8 |
| Connector | P-8 |
| Default | P-8 |
| Enable Input | P-8 |
| False | P-8 |
| Jumper | P-8 |
| Control Interface Board | P-9 |
| Parameter | P-9 |
| Press | P-9 |
| True | P-9 |

Control Logic Wiring and Adapters

Chapter 1

| | |
|--|------|
| Chapter Objectives | 1-1 |
| Chapter Overview | 1-1 |
| Control Interface Option | 1-2 |
| Control Interface Board Jumpers | 1-3 |
| Available Inputs | 1-4 |
| Standard Adapter Local Programming | 1-5 |
| Adapters and Communication Ports | 1-11 |
| Human Interface Module | 1-11 |
| Standard Adapter Ports | 1-12 |
| PLC Comm Adapter Ports | 1-13 |
| HIM Removal | 1-13 |
| HIM Operation | 1-14 |
| Graphic Programming Terminal | 1-14 |
| GPT Description | 1-14 |

| | | |
|--|---|------|
| | Drive Tools | 1-15 |
| | Control Firmware Function | 1-15 |
| | Chapter Objectives | 1-1 |
| Disassembly and Access Procedures | Chapter 2 | |
| | Chapter Objectives | 2-1 |
| | Disassembly and Access Overview | 2-1 |
| | Electrostatic Discharge Precautions | 2-1 |
| | Tools | 2-2 |
| | Fastener Torque Specifications | 2-2 |
| | Torque Sequence | 2-2 |
| | Two-Point Mounting | 2-2 |
| | Four-Point Mounting | 2-3 |
| | Torque Specifications | 2-4 |
| | Disassembly and Access Procedures | 2-5 |
| | Opening the Drive Enclosure | 2-5 |
| | Removal | 2-6 |
| | Installation | 2-6 |
| | Removing Control Interface L-Option Board MOD-L4, -L5, or -L6 | 2-7 |
| | Removal | 2-8 |
| | Installation | 2-8 |
| | Removing the Main Control Board | 2-9 |
| | Removal | 2-10 |
| | Installation | 2-10 |
| | Removing the Standard Adapter Board | 2-11 |
| | Removal | 2-12 |
| | Installation | 2-12 |
| | Removing the PLC Comm Adapter Board | 2-13 |
| | Removal | 2-14 |
| | Installation | 2-14 |
| | Removing the Control Board/Adapter Mounting Plate | 2-15 |
| | Removal | 2-15 |
| | Installation | 2-16 |
| | Removing the Precharge Board | 2-17 |
| | Removal | 2-17 |
| | Installation | 2-18 |
| | Removing the Gate Driver Board | 2-19 |
| | Removal | 2-19 |
| | Installation | 2-20 |
| | Removing the Snubber Board | 2-21 |
| | Removal | 2-22 |
| | Installation | 2-23 |
| | Accessing Chassis Power Components | 2-23 |

Component Test Procedures**Chapter 3**

| | |
|---|------|
| Chapter Objectives | 3-1 |
| Component Test Overview | 3-1 |
| Electrostatic Discharge Precautions | 3-2 |
| Tools | 3-2 |
| Test 1 | |
| Testing Input Rectifier SCR1 | 3-3 |
| Test 2 | |
| Testing the Bus Capacitor Bank | 3-5 |
| Test 3 | |
| Testing Power Modules PM1 – PM3 | 3-8 |
| Test 4 | |
| Testing Bus Fuse F1 | 3-10 |
| Test 5 | |
| Testing the Gate Driver Board | 3-12 |
| Test 6 | |
| Testing the Precharge Board | 3-14 |
| Test 7 | |
| Testing the Thermistor | 3-16 |

Part Replacement Procedures**Chapter 4**

| | |
|---|------|
| Chapter Objective | 4-1 |
| Part Replacement Overview | 4-1 |
| Safety Precautions | 4-1 |
| Electrostatic Discharge Precautions | 4-1 |
| Tools | 4-2 |
| Major Component Replacement | 4-2 |
| Detailed Product Identification | 4-2 |
| Ground Sense CT | 4-4 |
| Removal | 4-4 |
| Installation | 4-6 |
| Bus Fuse F1 | 4-6 |
| Removal | 4-7 |
| Installation | 4-7 |
| Thermistor | 4-8 |
| Removal | 4-8 |
| Installation | 4-9 |
| Power Modules PM1 – PM3 | 4-10 |
| Removal | 4-10 |
| Installation | 4-11 |
| Input Rectifier SCR1 | 4-12 |
| Removal | 4-12 |
| Installation | 4-13 |
| Fan | 4-14 |
| Removal | 4-15 |

| | | |
|--|--------------------------------------|------|
| | Installation | 4-16 |
| | DC Bus Inductor L1 | 4-17 |
| | Removal | 4-18 |
| | Installation | 4-19 |
| | Bus Capacitor Bank | 4-20 |
| | Removal | 4-20 |
| | Installation | 4-22 |
| Replacement Parts List | Chapter 5 | |
| | Chapter Objectives | 5-1 |
| | Ordering Replacement Parts | 5-1 |
| | Replacement Parts Listing | 5-2 |
| Schematics — 20 – 60 HP 1336 FORCE Drives | Chapter 6 | |
| Glossary | | |
| Index | | |

Preface

Manual Objective

The information in this manual is designed to help repair an Allen-Bradley Bulletin 1336 FORCE Adjustable Frequency AC Drive with ratings A020-A030, B040, B050, BX040, BX060, and C025–C060.

Who Should Use This Manual

This manual is intended for qualified service personnel responsible for repairing the 1336 FORCE Adjustable Frequency AC Drive. You should:

- Read this entire manual before performing maintenance or repairs to drives.
- Have previous experience with, and basic understanding of, electrical terminology, procedures, required equipment, equipment protection procedures and methods, and safety precautions.

This manual describes equipment and disassembly procedures. You begin with general illustrations and end with greater detail concerning replacement parts and part locations on the drives. Later chapters may refer you back to earlier chapters for information on basic equipment and steps necessary to perform detailed diagnostics and part replacement.

Safety Precautions



ATTENTION: Some printed circuit boards and drive components may contain hazardous voltage levels. Remove and lock out power before you disconnect or reconnect wires, and before you remove or replace fuses and circuit boards. Verify bus voltage by measuring the voltage between +DC and –DC on Terminal Block TB1. Do not attempt to service the drive until the bus voltage has discharged to zero volts.



ATTENTION: Potentially fatal voltages may result from improper usage of oscilloscope and other test equipment. The oscilloscope chassis may be at a potentially fatal voltage if not properly grounded. If an oscilloscope is used to measure high voltage waveforms, use only a dual channel oscilloscope in the differential mode with X 100 probes. It is recommended that the oscilloscope be used in the A minus B Quasi-differential mode with the oscilloscope chassis correctly grounded to an earth ground.



ATTENTION: Only personnel familiar with the 1336 FORCE Adjustable Frequency AC Drive and associated machinery should plan or implement the installation, start-up and subsequent maintenance of the system. Failure to comply may result in personal injury and/or equipment damage.

Electrostatic Discharge Precautions



ATTENTION: This assembly contains parts and sub-assemblies that are sensitive to electrostatic discharge. Static control precautions are required when servicing this assembly. Component damage may result if you ignore electrostatic discharge control procedures. If you are not familiar with static control procedures, reference Allen-Bradley Publication 8000-4.5.2, Guarding Against Electrostatic Damage, or any other applicable ESD protection handbook.

Electrostatic discharge generated by static electricity can damage the complimentary metallic oxide semiconductor devices on various drive boards. It is recommended that you perform these procedures to guard against this type of damage when circuit boards are removed or installed:

- Wear a wrist-type grounding strap that is grounded to the drive chassis.
- Attach the wrist strap before removing the new circuit board from the conductive packet.
- Remove boards from the drive and immediately insert them into their conductive packets.

1336 FORCE Product Identification

Drive Nameplate Location

The drive nameplate is located on the face of the Control Board Mounting Plate. The drive nameplate contains the drive's catalog number and other important drive information. Reference the catalog number when ordering replacement parts.

Figure P.1
Drive Nameplate Location

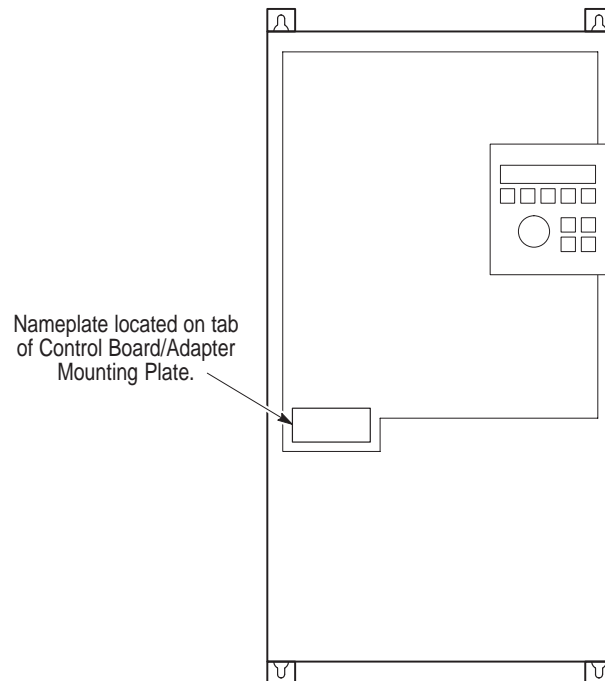

AB0334B

Software Compatibility



ATTENTION: To guard against machine damage and/or personal injury, drives with ratings above 45 kW (60 HP) must not be used with software versions below 1.07. Refer to the table below.

| Three-Phase Drive Rating ^① | | | | |
|---------------------------------------|--------------------------|----------------------------|---------------------------------|-----------------|
| 200 – 240V | 380 – 480V | 500 – 600V | Compatible with Version | Frame Reference |
| 15 – 22 kW 20 – 30 HP | 30 – 45 kW 40 – 60 HP | 18.5 – 45 kW 25 – 60 HP | 1.05 & Up or 1.06 w/std. Jog | C |

^① kW and HP are constant torque (CT) ratings.

Drive and Option Identification

The following is an explanation of the catalog numbering system for 1336 FORCE Adjustable Frequency AC Drives and options. The catalog number is coded to identify the drive power rating and can be found on the drive shipping carton and nameplate.

1336 FORCE Drive Catalog Numbers

Table P.A
200 – 240V AC Input, Constant Torque Drive

| 1336T | – A020-AN | | – GT2EN | – L6 | – HA1 | – GM1 |
|---------------------------|--------------------------------------|------------------|--|---|---|--|
| BULLETIN NO. | RATING-ENCLOSURE (MUST BE SPECIFIED) | | LANGUAGE MODULE ^① (MUST BE SPECIFIED) | CONTROL INTERFACE ^① (OPTIONAL) | HUMAN INTERFACE ^① (OPTIONAL) | COMMUNICATION CARD ^① (OPTIONAL) |
| Drive Rating ^② | | | Enclosures | | | |
| | | | Open IP00 No Enclosure | NEMA Type 1 IP20 General Purpose | NEMA Type 4 IP65 Resist Water, Dust | NEMA Type 12 IP54 Industrial Use |
| Frame Designation | Output Amps | Nominal HP/kW-CT | Code | Code | Code | Code |
| C | 65 | 20/15 | A020-AN | A020-AA | A020-AF | A020-AJ |
| | 77 | 25/18.5 | A025-AN | A025-AA | A025-AF | A025-AJ |
| | 80 | 30/22 | A030-AN | A030-AA | A030-AF | A030-AJ |

Table P.B
380 – 480V AC Input, Constant Torque Drive

| 1336T | – B040-AA | | – GT2EN | – L6 | – HA1 | – GM1 |
|---------------------------|--------------------------------------|---------------|--|---|---|--|
| BULLETIN NO. | RATING-ENCLOSURE (MUST BE SPECIFIED) | | LANGUAGE MODULE ^① (MUST BE SPECIFIED) | CONTROL INTERFACE ^① (OPTIONAL) | HUMAN INTERFACE ^① (OPTIONAL) | COMMUNICATION CARD ^① (OPTIONAL) |
| Drive Rating ^② | | | Enclosures | | | |
| | | | Open IP00 No Enclosure | NEMA Type 1 IP20 General Purpose | NEMA Type 4 IP56 Resist Water, Dust | NEMA Type 12 IP54 Industrial Use |
| Frame Designation | Constant Torque | | Code | Code | Code | Code |
| | Output Amps | Nominal HP/kW | | | | |
| C | 60 | 40/30 | B040-AN | B040-AA | B040-AF | B040-AJ |
| | 75 | 50/37 | B050-AN | B050-AA | B050-AF | B050-AJ |
| | 59 | 40/30 | BX040-AN | BX040-AA | BX040-AF | BX040-AJ |
| | 77 | 60/45 | BX060-AN | BX060-AA | BX060-AF | BX060-AJ |

Table P.C
500 – 600V AC Input, Constant Torque Drive

| 1336T | – C025-AA | | – GT2EN | – L6 | – HA1 | – GM1 |
|---------------------------|--------------------------------------|------------------|--|---|---|--|
| BULLETIN NO. | RATING-ENCLOSURE (MUST BE SPECIFIED) | | LANGUAGE MODULE ^① (MUST BE SPECIFIED) | CONTROL INTERFACE ^① (OPTIONAL) | HUMAN INTERFACE ^① (OPTIONAL) | COMMUNICATION CARD ^① (OPTIONAL) |
| Drive Rating ^② | | | Enclosures | | | |
| | | | Open IP00 No Enclosure | NEMA Type 1 IP20 General Purpose | NEMA Type 4 IP56 Resist Water, Dust | NEMA Type 12 IP54 Industrial Use |
| Frame Designation | Output Amps | Nominal HP/kW–CT | Code | Code | Code | Code |
| C | 30 | 25/18.5 | C025–AN | C025–AA | C025–AF | C025–AJ |
| | 35 | 30/22 | C030–AN | C030–AA | C030–AF | C030–AJ |
| | 45 | 40/30 | C040–AN | C040–AA | C040–AF | C040–AJ |
| | 57 | 50/37 | C050–AN | C050–AA | C050–AF | C050–AJ |
| | 62 | 60/45 | C060–AN | C060–AA | ③ | ③ |

① Refer to the Language Module and Options tables following these Catalog Number tables.

② 200 – 240V AC drive rating is based on nominal voltage of 240V and carrier frequency of 4kHz (60HP/45kW and below) or 2kHz (75HP/55kW and above) at altitudes of 1,000 meters or less. 380 – 480VAC drive rating is based on nominal voltage of 480V and carrier frequency of 4kHz (60HP/45kW and below) or 2kHz (75HP/55kW and above) at altitudes of 1,000 meters or less. 500 – 600V AC drive rating is based on nominal voltage of 600v and carrier frequency of 4kHz (60HP/45kW and below) or 2kHz (75HP/55kW and above) at altitudes of 1,000 meters or less. Refer to Drive Rating Qualifications on page P-6.

③ Not available at the time of this printing.

**Table P.D
Language Modules**

| Description | Option Code |
|------------------|-------------|
| English/English | EN |
| English/French | FR |
| English/German | DE |
| English/Italian | IT |
| English/Japanese | JP |
| English/Spanish | ES |

**Table P.E
Options**

| Code ^① | Description ^② | Code | Description ^② |
|--|--|---------------------------|------------------------------------|
| Human Interface Modules, NEMA Type 1 (IP20) | | Communication Options | |
| HAB | Blank – No Functionality | GT1EN | PLC Communication Adapter, English |
| HAP | Programmer Only | GT2EN | Standard Adapter, English |
| HA1 | Programmer/Controller with Analog Pot | GT0 | No Adapter |
| HA2 | Programmer/Controller with Digital Pot | | |
| Human Interface Modules, NEMA Type 4 (IP56) | | Control Interface Options | |
| HFP | Programmer Only | L4 | Contact Closure |
| HF2 | Programmer/Controller with Digital Pot | L5 | +24V AC/DC |
| | | L6 | 115V AC |
| Human Interface Modules, NEMA Type 12 (IP54) | | | |
| HJP | Programmer Only | | |
| HA2 | Programmer/Controller with Digital Pot | | |

^① Must be used in conjunction with a standard adapter option –GT2EN

^② For a more functionally complete description of each option refer to Publication 1336 FORCE-1.0.

Drive Rating Qualifications

Several factors can affect drive rating. If more than one factor exists, derating percentages must be multiplied. For example, if a 14-amp drive is installed at a 2km (6,600 ft.) altitude and has a 2% high-input line voltage, the actual amp rating is: 14 x 94% altitude derating x 96% high-input line derating = 12.6 amps

Enclosure Type

The first character, A, indicates the Enclosure Code.

The second character indicates the type of enclosure shipped from the factory:

Table P.F
Enclosure Type Code Description

| Enclosure Type Code | Description |
|---------------------|---------------------|
| N | Open style (IP00) |
| A | NEMA Type 1 (IP20) |
| F | NEMA Type 4 (IP65) |
| J | NEMA Type 12 (IP54) |

Conventions

To help differentiate parameter names and display text from other text in this manual, the following conventions will be used:

- Parameter Names will appear in [brackets].
- Display Text will appear in “quotes”.

The following is a list of conventions used throughout this manual, and definitions of the conventions. For a list of terminology and definitions, refer to the Glossary in the back of this manual.

Auxiliary Input

The Auxiliary Input is a terminal connection on the Control Interface Board. This connection provides an external input for use as an Auxiliary Interlock. Unless this interlock is closed, the drive will be faulted with an Auxiliary Fault.

Auxiliary Interlock

The Auxiliary Interlock is a user supplied circuit consisting of reset, overload, or other interlocking circuitry. The Interlock is wired to the drive Auxiliary input.

Bit

A bit is a single character or status point used in programmable logic. Eight bits form a BYTE, 16 bits form a word. Drive parameters are actually eight bits or 16 bit words.

Check

To check means to examine either the physical condition of something or the setting of some control, such as a Parameter. Checking a drive board or component may also require measurements and tests.

Connector

A connector connects one drive board to another. Connectors come in two designs, male and female. Male connectors are stationary and contain pins, which are sometimes joined by jumpers. Female connectors are at the ends of wires or ribbon cables and plug into male connectors.

Default

When a drive function defaults, it automatically changes to a pre-programmed setting.

Enable Input

The Enable Input is a terminal connection on the Control Interface Board. This connection provides an external input to enable or disable the Drive Output section. It must be true to permit the drive to operate.

False

False refers to a logical false state. For instance, a Control Interface signal on TB3 is false when the input contact is open or the appropriate voltage is not applied to the Control Interface Board.

Jumper

A jumper completes a circuit between two pins within a male connector on a drive board. In the absence of certain optional equipment using female connectors, jumpers are applied to certain pins within a male connector to complete specific and necessary circuits.

Control Interface Board

A Control Interface Board plugs into connectors J7 and J9, located on the lower portion of the Standard Adapter Board. This board is identified as L4, L5, or L6 and provides optional control wiring configurations for a drive.

Parameter

Parameters are programmable drive functions that define various operating functions or status displays of a drive. Refer to Bulletin 1336 FORCE Adjustable Frequency AC Drive User Manual for Parameter details.

Press

Press a button on the Human Interface Module to change Parameter settings and drive functions.

True

True refers to a logical true state. For instance, a Control Interface signal on TB3 is true when: L4 contact input is closed, L5 input terminal registers 24V, or L6 input terminal registers 115V AC.

Related Publications

The following lists other Allen-Bradley publications that apply to the 1336 FORCE Adjustable Frequency AC Drives with ratings A020-A030, B040, B050, BX040, BX060, and C025-C060:

- Product Data Drive Tools Software (9303-2.0)
- User Manual Bulletin 1201 Graphic Programming Terminal (1201-5.0)
- Product Pricing Bulletin (1336 FORCE-3.0)
- User Manual 1336 FORCE Field Oriented Control (1336 FORCE-5.12)
- User Manual 1336 FORCE PLC Communications Adapter (1336 FORCE-5.13)
- Renewal Parts List (1336-6.5)
- Options Manuals/Instructions

This Page Intentionally Left Blank

Control Logic Wiring and Adapters

Chapter Objectives

This chapter introduces you to terminal block locations and wiring and adapter locations and functions.

Chapter Overview

This chapter illustrates and describes Standard Adapter Board:

- Control Logic Interface Options L4, L5, and L6, including terminal block TB3.
- TB3, input mode selections and functions
- TB3, TB5, TB6, TB7 terminal designations

This chapter illustrates and describes the following terminal designations for the PLC Comm Adapter Board:

- TB20
- TB21

Important: All printed circuit boards, except the Main Control Board assembly, are referenced to negative ground (–bus).



ATTENTION: Some printed circuit boards and drive components may contain hazardous voltage levels. Remove power before you disconnect or reconnect wires, and before you remove or replace fuses and circuit boards. Verify bus voltage by measuring the voltage between +DC and –DC on Terminal Block TB1. Do not attempt to service the drive until the bus voltage has discharged to zero volts.



ATTENTION: This assembly contains parts and sub-assemblies that are sensitive to electrostatic discharge. Static control precautions are required when servicing this assembly. Component damage may result if you ignore electrostatic discharge control procedures. If you are not familiar with static control procedures, reference Allen-Bradley Publication 8000–4.5.2, Guarding Against Electrostatic Discharge, or any other applicable ESD protection handbook.

Figure 1.1
Terminal Block Locations

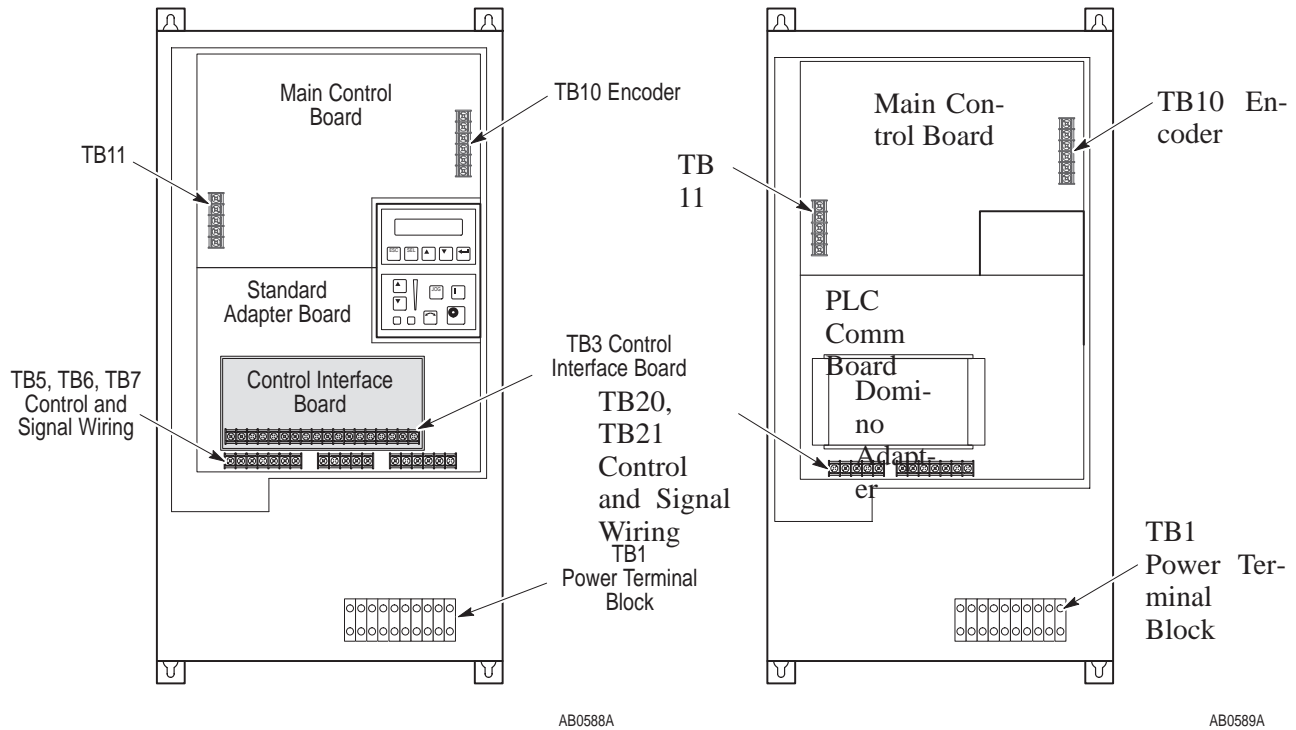

AB0588A

AB0589A



ATTENTION: The National Electrical Code (NEC) and local codes outline provisions for safely installing electrical equipment. Installation must comply with specifications regarding wire types, conductor sizes, branch circuit protection and disconnect devices. Failure to do so may result in personal injury and/or equipment damage.

Control Interface Option

The Control Interface Option provides a means of interfacing various signals and commands to the 1336 FORCE by using contact closures.

Three different versions of the option are available:

- L4 Contact Closure Interface¹
- L5 +24V AC/DC Interface
- L6 115V AC Interface

¹ Uses internal +5V DC supply.

The user inputs are connected to the option board through TB3. The L4, L5 and L6 options each have nine control inputs. The function of each input must be selected through programming as explained later in this section.

Control Interface Board Jumpers

Important: If the Control Interface Board is being installed, Main Control Board jumpers at pins 3 & 4 and 17 & 18 of J4 (J7 on 7.5 – 30 HP drives) must be removed. If this board is removed, these jumpers must be reinstalled and the [Input Mode] parameter must be programmed to “1”.

Figure 1.2
Jumper Locations

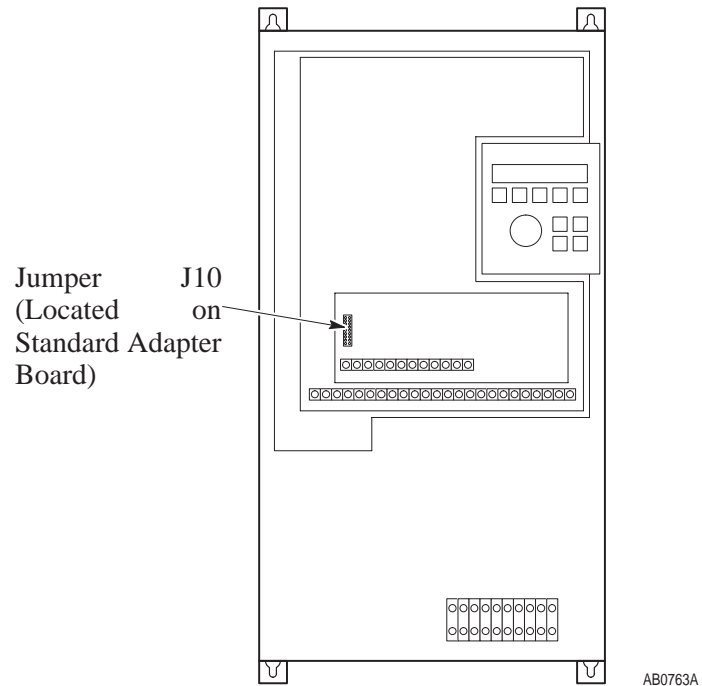

Available Inputs

A variety of combinations made up of the following inputs are available.

| | |
|-----------------------------|---------------------|
| Start | Enable |
| Stop/Clear Fault | Auxiliary |
| Reverse | 2 Stop Mode Selects |
| Digital Potentiometer (MOP) | Run Forward |
| 2 Accel/Decel Rates | Run Reverse |
| 3 Speed Selects | Local Control |

The available combinations are shown in Figure 1.4. Programming the [Input Mode] parameter to one of the Input Mode numbers listed selects that combination of input functions.

Important: The [Input Mode] parameter can be changed at any time; however, programming changes will not take affect until power has been cycled to the drive. When changing an input mode, it is important to note that the corresponding inputs to TB3 may also change.

The programming options of the Control Interface Option allow the user to select an input combination to meet the needs of a specific installation. Appropriate selection of a combination may be done by using Table 1.A. First determine the type of start/stop/direction control desired. Then select the remaining control functions available. After selecting a group of Input Modes use Table 1.A for specific mode selection. Record the selected mode number below.

Selected Mode Number: _____

Standard Adapter Local Programming

For local programming and control information, refer to the 1336 FORCE User Manual.

Table 1.A
Input Mode Selection

| Start/Stop Type | Direction Control | Communication Compatibility | Mode(s) to Use |
|---|--|--|----------------|
| Stop & Enable Only | None | Control must be provided by HIM or Communication Option. | 1 |
| Momentary Pushbutton (3 Wire) | Maintained Switch (Open-Forward, Closed-Reverse) | Start/Stop – works in parallel with HIM and Communication Options. Direction Control will not work in parallel with HIM or Communication Options. User must select direction control from either HIM and Communication Options or TB3 input. | 2-6 |
| Momentary Pushbutton (3 Wire) | Momentary Pushbuttons (Forward and Reverse) | Start/Stop – works in parallel with HIM and Communication Options. Direction – works in parallel with HIM or Communication Options. | 7-11 |
| Maintained switches for combined run and direction control (2 wire, Run Forward, Run Reverse) | | Start/Stop – not compatible with HIM or Communication Options. Direction – not compatible with HIM or Communication Options. | 12-16 |

The maximum and minimum wire sizes accepted by TB3 is 2.1 and 0.30 mm² (14 and 22 AWG). Maximum torque for all terminals is 0.9 – 1.13 N-m (8–10 lb-in.).

Figure 1.3
TB3 Terminal Designations

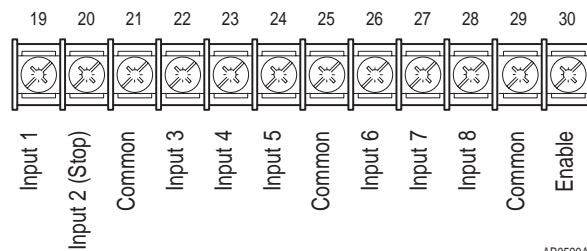

AB0590A

Figure 1.4
Input Mode Selection and Typical TB3 Connections

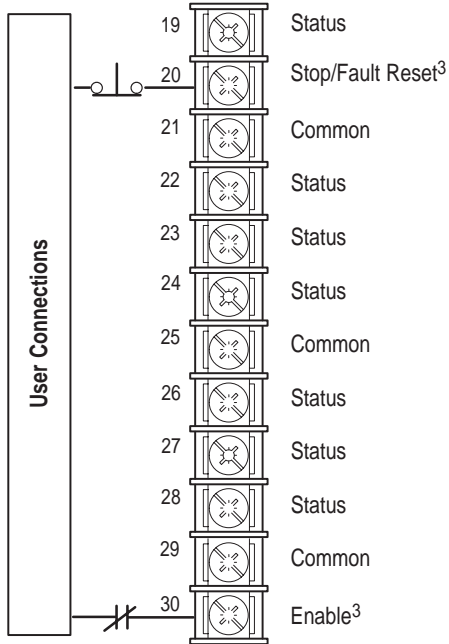
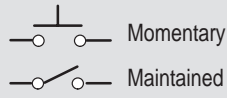

**[Input Mode] 1
Factory Default**

Note: If this mode is selected, the status of all inputs can be read at the [Input Status] parameter. However, only "Stop/Fault Reset" and "Enable" will have control function.

**[Input Mode] 2 – 6
Three-Wire Control with Single-Source Reversing**

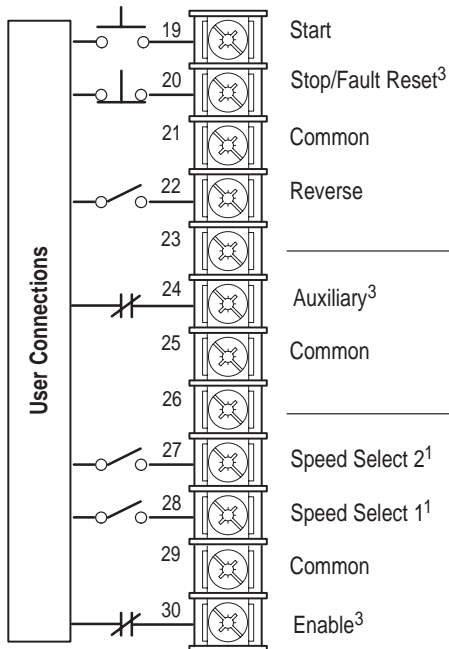

| | | Mode | | | | |
|--|--|-----------------------------|-----------------------------|-----------|----------------|----------------------------|
| | | 2 | 3 | 4 | 5 | 6 |
| | | Jog | Stop Type | 2nd Accel | Digital Pot Up | Jog |
| | | Speed Select 3 ¹ | Speed Select 3 ¹ | 2nd Decel | Digital Pot Dn | Local Control ² |

1 See Table 1.B.

2 Drive must be stopped to take Local Control. Control by all other adapters is disabled (except Stop).

3 These inputs must be present before drive will start.

ATTENTION: The JOG function will not operate properly unless a SCANport option is connected to the drive. To assure proper JOG function, install at least one of the following:

- 1201-HAP, 1201-HA1, 1201-HA2, 1336-GM1. Applies to 1305 with firmware FRN 2.01 or earlier and 1336 PLUS with Language Module 1336S-EN firmware FRN 1.05 or earlier.



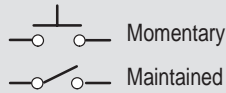

ATTENTION: The JOG function will not operate properly unless a SCANport option is connected to the drive. To assure proper JOG function, install at least one of the following:
 1201-HAP, 1201-HA1, 1201-HA2, 1336-GM1. Applies to 1305 with firmware FRN 2.01 or earlier and 1336 PLUS with Language Module 1336S-EN firmware FRN 1.05 or earlier.

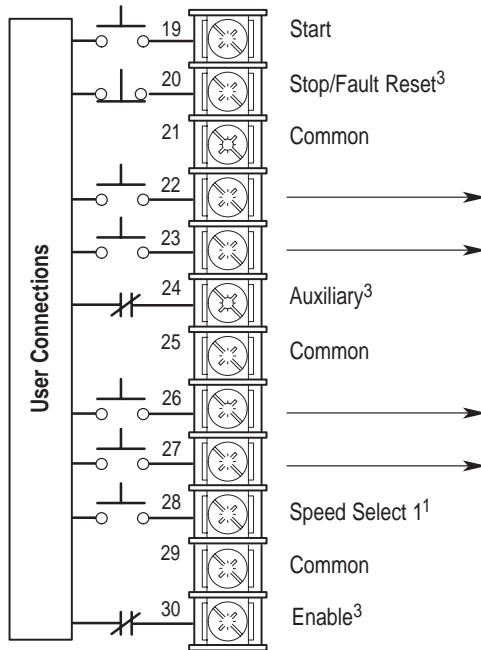

[Input Mode] 7 – 11
Three-Wire Control with Multi-Source Reversing

| | Mode | | | | |
|-----------------|---------|-----------------|-----------------|----------------|-----------|
| | 7 | 8 | 9 | 10 | 11 |
| Reverse | Reverse | Reverse | Digital Pot Up | Reverse | 1st Accel |
| Forward | Forward | Forward | Digital Pot Dn | Forward | 2nd Accel |
| Jog | | Speed Select 3¹ | Speed Select 3¹ | Digital Pot Up | 1st Decel |
| Speed Select 2¹ | | Speed Select 2¹ | Speed Select 2¹ | Digital Pot Dn | 2nd Decel |

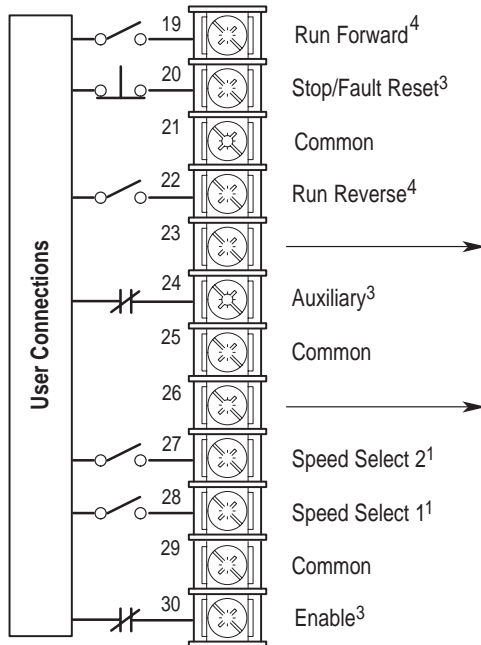

[Input Mode] 12 – 16
Two-Wire Control, Single-Source Control

| | Mode | | | | |
|-----------------|-----------------|-----------------|-----------|----------------|----------------|
| | 12 | 13 | 14 | 15 | 16 |
| Local Control² | Local Control² | Stop Type | 2nd Accel | Digital Pot Up | Local Control² |
| Speed Select 3¹ | Speed Select 3¹ | Speed Select 3¹ | 2nd Decel | Digital Pot Dn | Stop Type |

1 See Table 1.B.

2 Drive must be stopped to take Local Control. Control by all other adapters is disabled (except Stop).

3 These inputs must be present before drive will start.

4 Bit 0 of [Direction Mask] must = 1 to allow operation.

AB0291B

The following table defines the input state of the Speed Select inputs for a desired frequency source.

Table 1.B
Speed Select Input State vs. Velocity Reference Source

| Para 52 TB3 | Speed Select 3 Bit 14 Terminal 26 | Speed Select 2 Bit 13 Terminal 27 | Speed Select 1 B12 Terminal 28 | Velocity Reference Source |
|----------------|---|---|--------------------------------------|------------------------------|
| | O | O | O | Last State |
| | O | O | X | External Reference 1 |
| | O | X | O | Preset Speed 1 |
| | O | X | X | Preset Speed 2 |
| | X | O | O | Preset Speed 3 |
| | X | O | X | Preset Speed 4 |
| | X | X | O | Preset Speed 5 |
| | X | X | X | External Reference 2 |

O = Open — Input Removed

X = Closed — Input Present

The DIP switches and jumpers on the PLC Communications Board have been preset at the factory. Communication is received through Channels A and B. This communication protocol is defined through SW U2 – U5. If switches or jumpers require reconfiguration, refer to the 1336 FORCE PLC Communications Adapter User Manual.

Figure 1.5
PLC Comm Adapter Reference Signal Connections

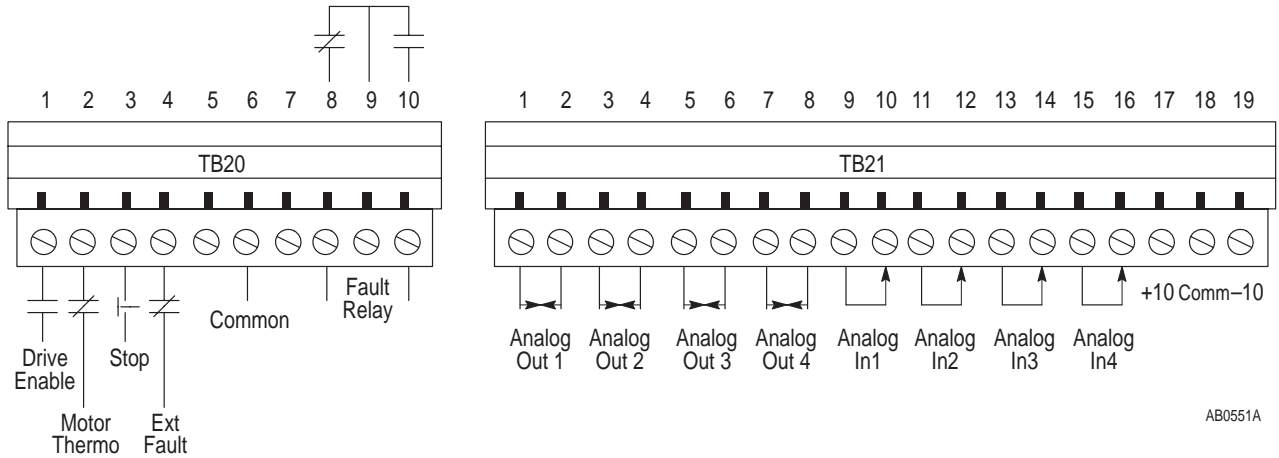

AB0551A

Table 1.C
PLC Comm Adapter Reference Signal Connections

| Terminal Block | Terminal Number(s) | Signal |
|----------------|--------------------|------------------------|
| TB20 | 1 | Drive Enable (NO) |
| | 2 | Motor Thermoguard (NC) |
| | 3 | Normal Stop (NC) |
| | 4 | External Fault (NC) |
| | 5 | |
| | 6 | Input Common |
| | 7 | |
| | 8 | Fault Output (NC) |
| | 9 | Fault Output (COM) |
| | 10 | Fault Output (NO) |
| TB21 | 1 | OUT 1 |
| | 2 | COM 1 |
| | 3 | COM 2 |
| | 4 | OUT 2 |
| | 5 | OUT 3 |
| | 6 | COM 3 |
| | 7 | OUT 4 |
| | 8 | COM 4 |
| | 9 | IN 1+ |
| | 10 | IN 1- |
| | 11 | IN 2+ |
| | 12 | IN 2- |
| | 13 | IN 3+ |
| | 14 | IN 3- |
| | 15 | IN 4+ |
| | 16 | IN 4- |
| | 17 | +10V |
| | 18 | COM |
| | 19 | -10V |

Adapters and Communication Ports

Human Interface Module

When the drive-mounted HIM is supplied, it will be connected as Port 1 (refer to Figure 1.7) and visible from the front of the drive. The HIM can be divided into two sections; Display Panel and Control Panel. The Display Panel provides a means of programming the drive and viewing the various operating parameters. The Control Panel allows different drive functions to be controlled. Refer to the 1336 FORCE User Manual for HIM operation.

Important: The operation of HIM functions depends upon drive parameter settings. Default parameter values allow full HIM functionality.

Figure 1.6
Human Interface Module, Standard Adapter Only

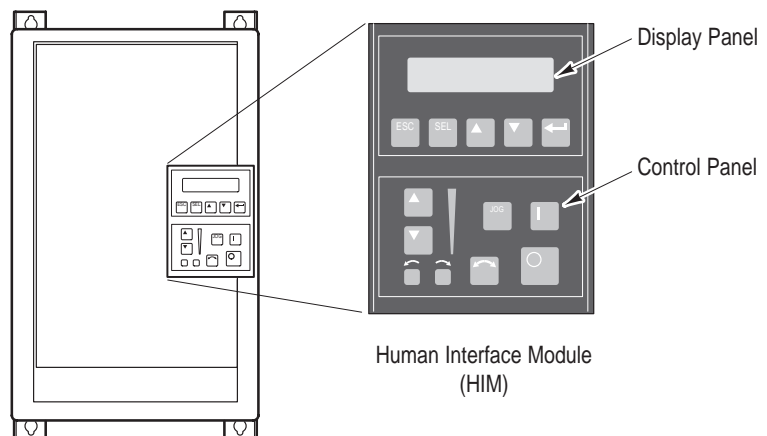

AB0268B

Standard Adapter Ports

Figure 1.7
Standard Adapter Board Port Locations

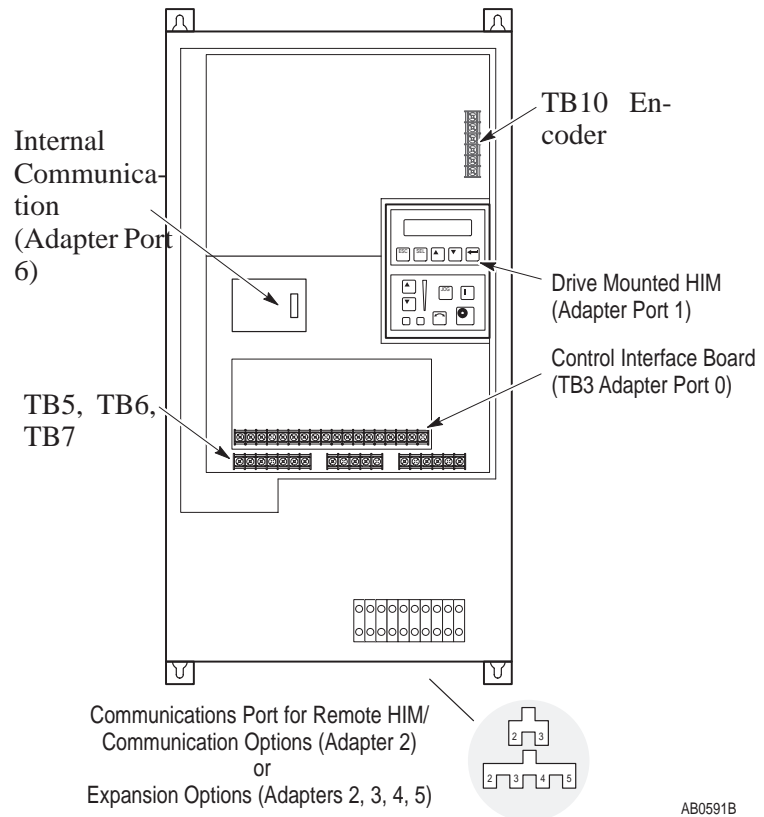

PLC Comm Adapter Ports

Figure 1.8
PLC Comm Adapter Board Port Locations

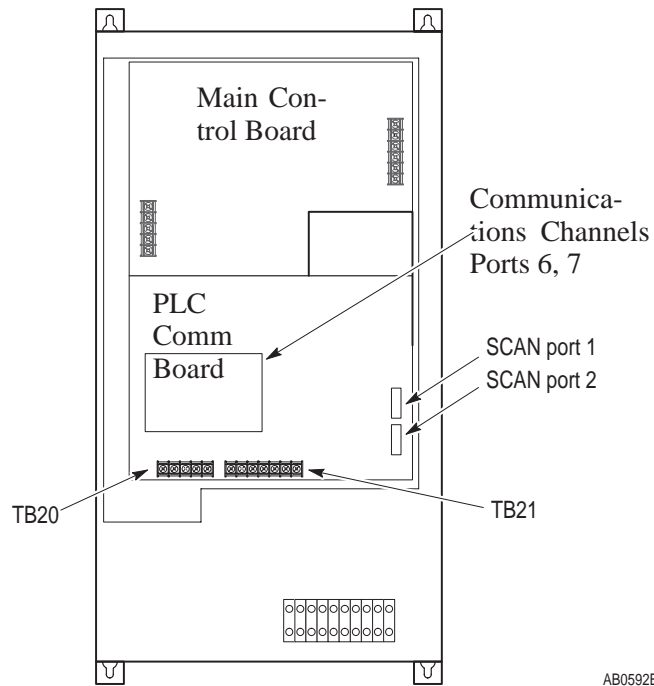

HIM Removal



ATTENTION: Some voltages present behind the drive front cover are at incoming line potential. To avoid an electric shock hazard, use extreme caution when removing/replacing the HIM.

For handheld operation, the module can be removed and located up to 10 meters (33 feet) from the drive.

Important: Power must be removed from the drive or Bit 1 of the [Logic Mask] parameter must be set to “0” to allow removal of the HIM module without causing a Communication Fault. Setting Bit 1 of the [Logic Mask] parameter to “0” allows HIM removal while power is applied to the drive. Note that this also disables all HIM control functions except Stop.

To remove the module:

1. Ensure that power has been removed or [Logic Mask] has been set to "0".
2. Take the drive front cover off and simply slide the module down and out of its cradle. Remove cable from module.
3. Connect the appropriate cable between the HIM and the Communications Port (Adapter 2, 3, 4, or 5).
4. Reverse the above steps to replace the module. Apply power or reset Bit 1 of the [Logic Mask] parameter to "1" to enable HIM control.

HIM Operation

When power is first applied to the drive, the HIM will cycle through a series of displays. These displays will show drive ID and communication status. Upon completion, the Status Display (see Figure 1.9) will be shown. This display shows the current status of the drive (i.e. Stopped, Running, etc.) or any faults that may be present (Not Enabled, etc.). Refer to the 1336 FORCE User Manual for HIM operation.

Figure 1.9
Status Display

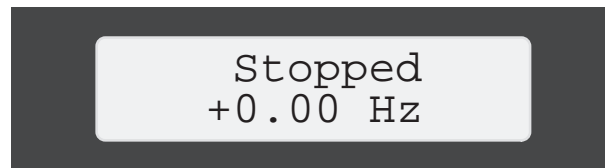

Graphic Programming Terminal

GPT Description

The optional GPT (Figure 1.10) is a remote device with a 1.8 meter (6 foot) long cable. The GPT offers a 40-by-8 character display that can also be used as a graphics display to show trending graphs. For GPT operation, refer to the 1336 FORCE Field Oriented Control User Manual. See also the 1201 GPT User Manual.

Important: Main Menu screens are dynamic and will change based on functionality provided by adapter and drive status.

Figure 1.10
Graphic Programming Terminal

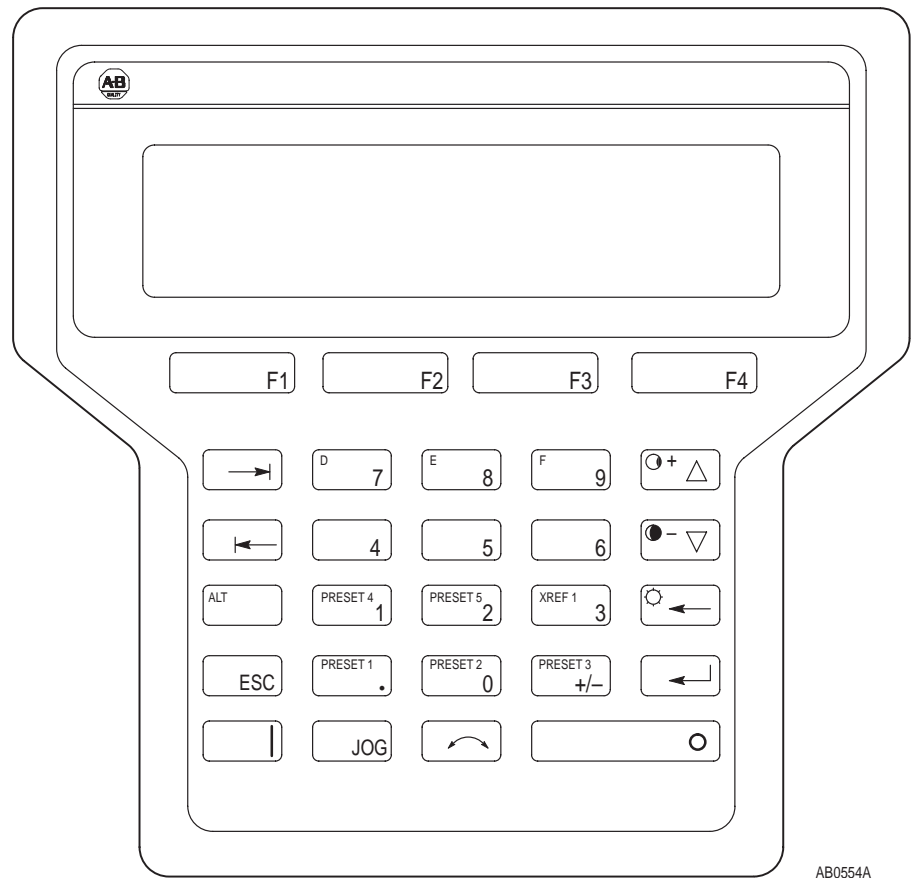

Drive Tools

Drive Tools software is a Windows 3.1 compatible family of application programs allowing the user to perform programming, monitoring, and diagnostic operations on Allen-Bradley AC and DC digital drive products. The software consists of five Windows applications. For operation, refer to the Product Data Drive Tools Software manual.

Control Firmware Function

All control functions in the 1336 FORCE are performed through the use of parameters that can be changed with a programming terminal or Drive Tools. Refer to an overview Block Diagram of the Control Firmware Function in the 1336 FORCE Field Oriented Control User Manual.

Feedback information is derived from hardware devices as part of the process equipment used. Analog signals are converted to digital signals for use by the drive. Control signals may be provided to the drive by one of two Adapter Boards.

All setup and operation information used by the drive is stored in a system parameter table. Every parameter, including Setup and Configuration parameters (Sources and Sinks), has an entry in the parameter table. For example, parameter 101 is named the “Velocity Reference 1 HI (whole)” parameter and contains a number value representing the velocity reference. The velocity reference can originate from an external control device such as a potentiometer connected to the analog input of an Adapter board or a signal coming in via RIO from a PLC. Refer to the 1336 FORCE User Manual, Publication 1336 FORCE-5.12.

Disassembly and Access Procedures

Chapter Objectives

This chapter describes general disassembly procedures required to access internal drive components.

Disassembly and Access Overview



ATTENTION: Some printed circuit boards and drive components may contain hazardous voltage levels. Remove and lock out power before you disconnect or reconnect wires, and before you remove or replace fuses and circuit boards. Verify bus voltage by measuring the voltage between +DC and –DC on Terminal Block TB1. Do not attempt to service the drive until the bus voltage has discharged to zero volts.



ATTENTION: Servicing energized industrial control equipment can be hazardous. Electrical shock, burns, or unintentional actuation of controlled industrial equipment may cause death or serious injury. Follow the safety-related practices of NFPA 70E, Electrical Safety for Employee Workplaces, when working on or near energized equipment. Do not work alone on energized equipment.

Electrostatic Discharge Precautions



ATTENTION: This assembly contains parts and sub-assemblies that are sensitive to electrostatic discharge. Static control precautions are required when servicing this assembly. Component damage may result if you ignore electrostatic discharge control procedures. If you are not familiar with static control procedures, reference Allen-Bradley Publication 8000-4.5.2, Guarding Against Electrostatic Discharge, or any other applicable ESD protection handbook.

Electrostatic discharge generated by static electricity can damage the complimentary metallic oxide semiconductor devices on various drive boards. It is recommended that you perform these procedures to guard against this type of damage when circuit boards are removed or installed:

- Wear a wrist type grounding strap that is grounded to the chassis.
- Attach the wrist strap before removing the new circuit board from the conductive packet.
- Remove boards from the drive and immediately insert them into their conductive packets.

Tools

You need the following tools to disassemble and assemble the drive:

- Pliers
- Phillips screwdriver
- Standard screwdriver
- 5/16-inch or 8 mm socket
- 11/16-inch or 17 mm socket
- 5/16-inch or 8 mm open-end wrench
- Torque wrench, metered in lb-in. or N-m

Fastener Torque Specifications

Torque Sequence

When mounting components to a drive's heat sink, component-fastener torque sequences and tolerances are crucial to component-to-heat sink heat dissipation.



ATTENTION: Component can be damaged if temporary tightening procedure is not performed to specification.

Two-Point Mounting

The following illustrates temporary and final tightening sequences for components fastened to a heat sink using two screws. Temporary torque is 1/3 (33%) of final torque. The numeric illustration labels are for your assistance. Drive components do not carry these labels.

Figure 2.1
Two-Point Mounting

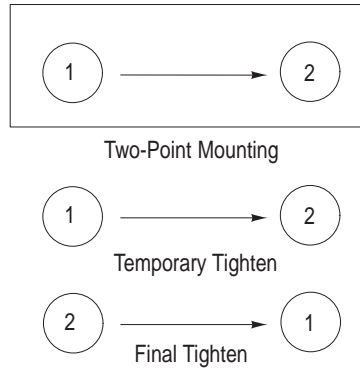

AB0016A

Four-Point Mounting

The following illustrates temporary and final tightening sequences for components fastened to a heat sink using four screws. Temporary torque is 1/3 (33%) of final torque. The numeric illustration labels are for your assistance. Drive components do not carry these labels.

Figure 2.2
Four-Point Mounting

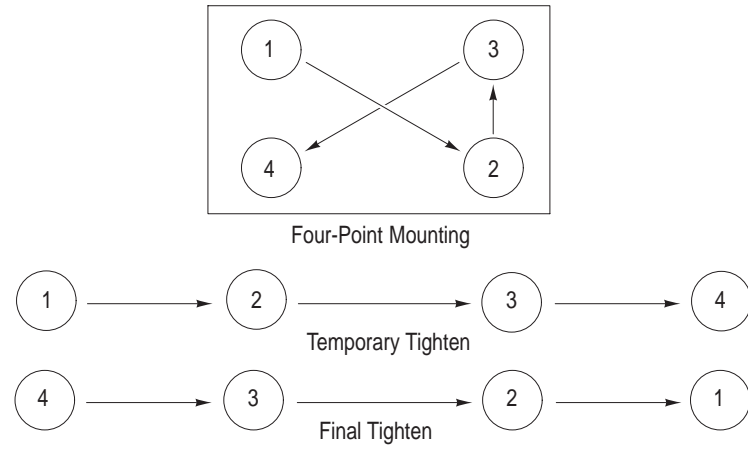

AB0017A

Torque Specifications

The following table lists fastener locations by component, how the fasteners are used, and torque specifications. Refer to Torque Sequence in this chapter for fastening two-point and four-point components to the heat sink.

Table 2.A
Fastener Torque Specifications

| Component | Fastener Application | Torque lb-in. | Torque N-m |
|---------------------------|-------------------------------|-------------------|---------------|
| Bus Capacitor Bank | Bank to chassis | 25-31 | 2.8-3.5 |
| DC Bus Inductor | Wires to bus bars | 25-31 | 2.8-3.5 |
| DC Bus Inductor | TB1 mounting plate to chassis | 25-31 | 2.8-3.5 |
| Snubber Board | Bus bars to capacitor bank | 25-31 | 2.8-3.5 |
| Snubber Board | Board to SCR1 | 30-39 | 3.4-4.4 |
| Snubber Board | Board to PM1 – PM3 | 25-31 | 2.8-3.5 |
| Power Modules PM1 – PM3 | Module to heat sink | 25-31 | 2.8-3.5 |
| Input Rectifier | Rectifier to heat sink | 200-220 | 22.6-24.8 |
| Bus Fuse F1 | Fuse to chassis | | |
| Thermistor | Thermistor to heat sink | Hand tighten only | |
| TB1 | Wires to terminals | 25-31 | 2.8-3.5 |
| TB5, 6, 7, 10, 11, 20, 21 | Wires to terminals | 8-10 | 0.9-1.1 |
| TB3 | Wires to terminals | 8-10 | 0.9-1.1 |
| Ground Sense CT | Bracket to chassis | 25-31 | 2.8-3.5 |
| Ground Sense CT | Positive bus bar junction | 25-31 | 2.8-3.5 |
| Ground Sense CT | Bus bars to capacitor bank | 25-31 | 2.8-3.5 |
| Standard Adapter Board | Board to Mounting Plate | 12-16 | 1.4-1.8 |
| PLC Comm Adapter Board | Board to Mounting Plate | 12-16 | 1.4-1.8 |
| Main Control Board | Board to Mounting Plate | 12-16 | 1.4-1.8 |

Disassembly and Access Procedures

Opening the Drive Enclosure

Figure 2.3
Drive Enclosure

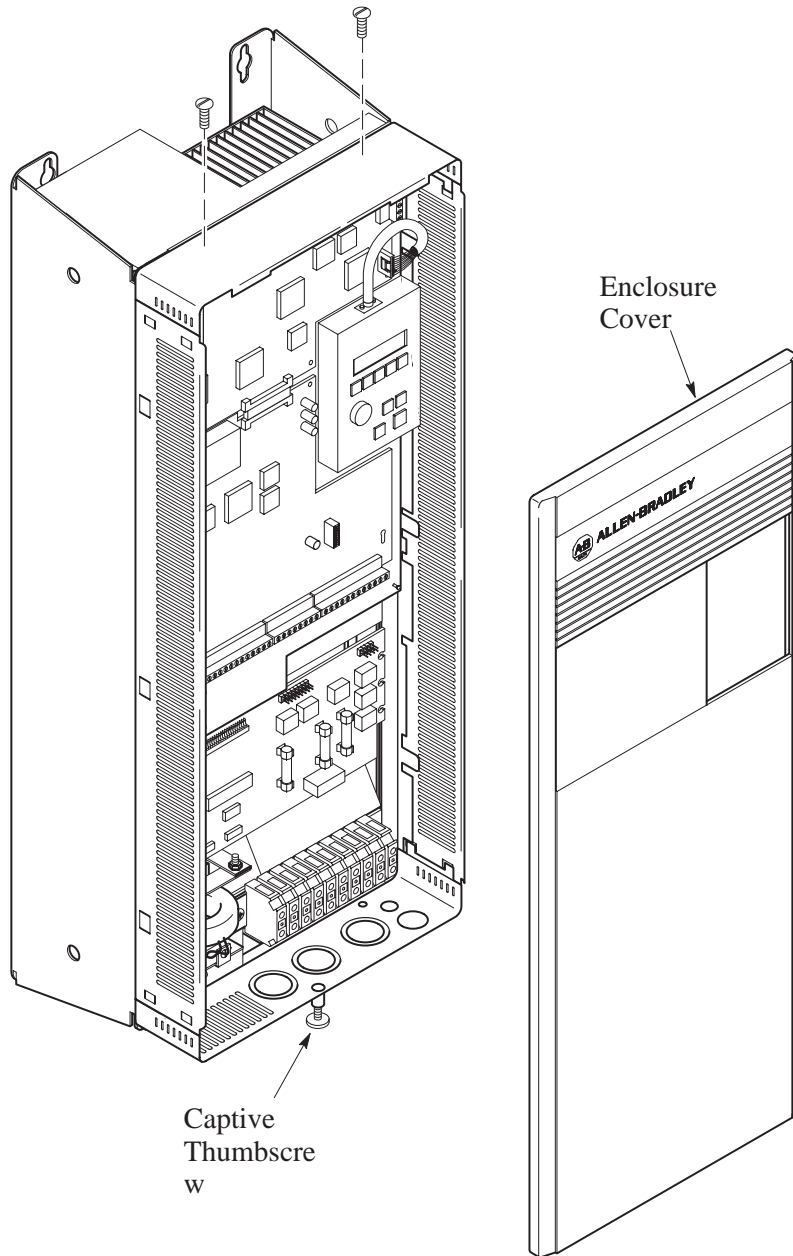

AB0765A

Removal



ATTENTION: Disconnect and lock out power from the drive before disassembling the drive. Failure to disconnect power may result in death or serious injury. Verify bus voltage by measuring the voltage between +DC and –DC on Terminal Block TB1. Do not attempt to service the drive until the bus voltage has discharged to zero volts.



ATTENTION: Wear a wrist-type grounding strap when servicing 1336 FORCE Drives. Failure to protect drive components against ESD may damage drive components. Refer to Electrostatic Discharge Precautions at the beginning of this chapter.

1. Remove power from the drive.
2. Loosen the captive thumb screw fastening the Enclosure cover to the bottom of the Enclosure frame.
3. Pull the bottom of the Enclosure cover outward to clear the frame, then lift the cover upward to remove the cover.
4. Check for zero volts at TB1 terminals +DC and –DC.
5. Check for absence of control voltage at:
 - TB20 and TB21 on drives using a PLC Comm Adapter Board
 - TB5, TB6, and TB7 on drives using a Standard Adapter Board
6. Remove the customer-supplied wiring from the drive.
7. Remove the screws from the Enclosure top panel. Note the tab slots in the top panel holding the side panels into place.
8. Lift the Enclosure side panels out of the Enclosure bottom-panel tab slots to remove the side panels.

Installation

Install the Enclosure in reverse order of removal.



ATTENTION: Replace all guards and insulators before applying power to the drive. Failure to replace guards may result in death or serious injury.

Removing Control Interface L-Option Board MOD-L4, -L5, or -L6

Figure 2.4
Control Interface Board

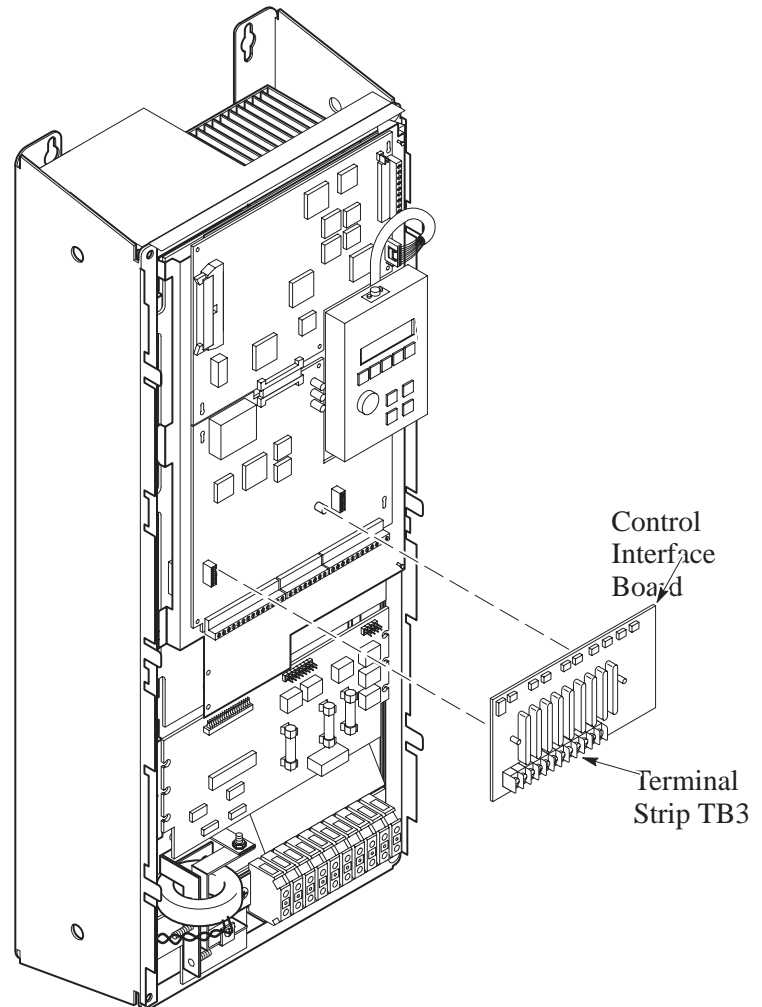

AB0764A

Removal



ATTENTION: Disconnect and lock out power from the drive before disassembling the drive. Failure to disconnect power may result in death or serious injury. Verify bus voltage by measuring the voltage between +DC and –DC on Terminal Block TB1. Do not attempt to service the drive until the bus voltage has discharged to zero volts.



ATTENTION: Wear a wrist-type grounding strap when servicing 1336 FORCE Drives. Failure to protect drive components against ESD may damage drive components. Refer to Electrostatic Discharge Precautions at the beginning of this chapter.

Important: Before you remove connections and wires from the drive components, mark the connections and wires to correspond with their component connections and terminals to prevent incorrect wiring during assembly.

1. Remove power from the drive.
2. Check for zero volts at TB1 terminals +DC and –DC.
3. Check for absence of control voltage at TB5, TB6, and TB7 on the Standard Stapter Board.
4. Open the Enclosure cover if the drive has an enclosure. Refer to Opening the Drive Enclosure in this chapter.
5. Remove all wires from the terminals on TB3.
6. Loosen the two captive screws fastening the Control Interface Board to the Standard Adapter Board.
7. Grip the right and left sides of the Control Interface Board and pull the board straight outward from the Standard Adapter Board.

Installation

Install the Control Interface Board in reverse order of removal.



ATTENTION: Replace all guards and insulators before applying power to the drive. Failure to replace guards may result in death or serious injury.

Removing the Main Control Board

Figure 2.5
Main Control Board

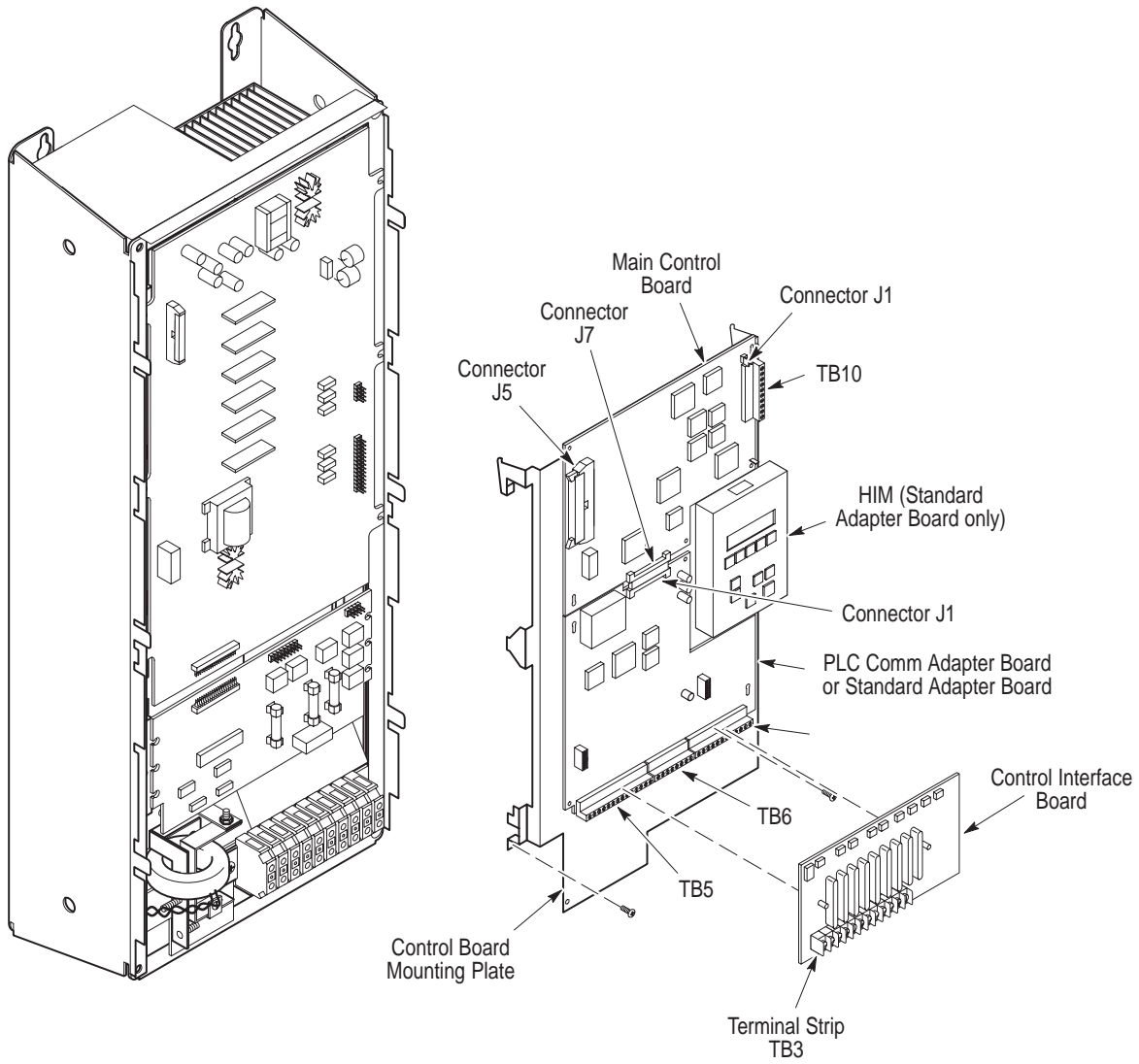

AB0580A

Removal



ATTENTION: Disconnect and lock out power from the drive before disassembling the drive. Failure to disconnect power may result in death or serious injury. Verify bus voltage by measuring the voltage between +DC and –DC on Terminal Block TB1. Do not attempt to service the drive until the bus voltage has discharged to zero volts.

1. Remove power from the Drive.
2. Open the Enclosure Cover. Refer to Opening the Drive Enclosure in this chapter.
3. Check for zero volts at TB1 Terminals +DC and –DC.
4. Check for the absence of control voltage at:
 - TB20 and TB21 on drives using a PLC Comm Adapter Board
 - TB5, TB6, and TB7 on drives using a Standard Adapter Board
5. Disconnect the following from the Main Control Board:
 - J5 ribbon cable connector.
 - J1 connector
 - Stake-on ground wire connector
 - All wires from TB10
6. Remove the screws fastening the Main Control Board to the mounting plate.
7. Lift the Main Control Board upward to release it from the slide-mount stand-offs and connector J7.

Installation

Install the Main Control Board in reverse order of removal.



ATTENTION: Replace all guards and insulators before applying power to the drive. Failure to replace guards may result in death or serious injury.

Removing the Standard Adapter Board

Figure 2.6
Standard Adapter Board

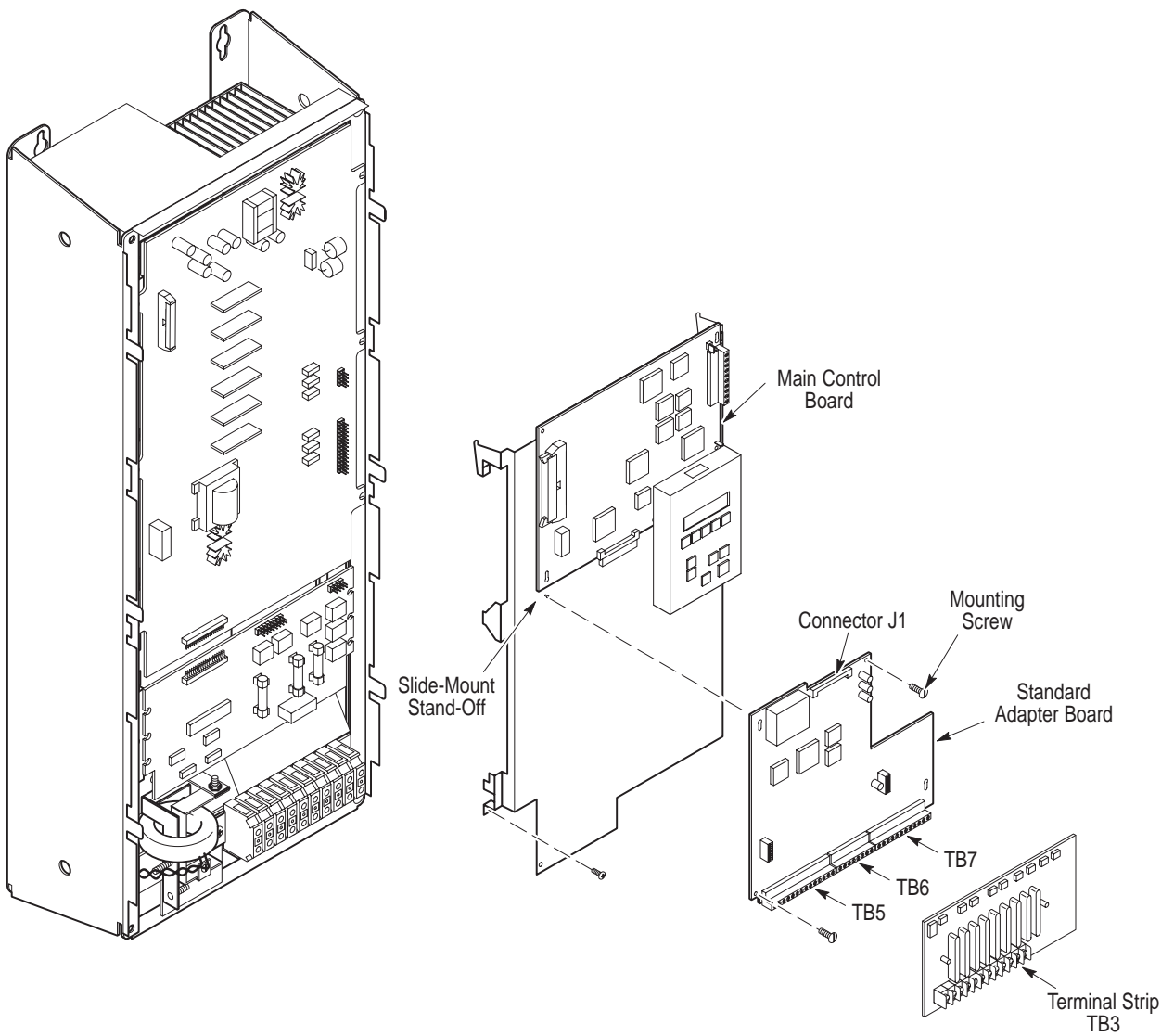

AB0581A

Removal

1. Remove power from the Drive.
2. Open the Enclosure Cover. Refer to Opening the Drive Enclosure in this chapter.
3. Check for zero volts at TB1 Terminals +DC and –DC.
4. Check for the absence of control voltage at TB5, TB6, and TB7 on the Standard Adapter Board.
5. Disconnect the following from the Standard Adapter Board:
 - Stake-on ground wire connector
 - All wires from TB5, TB6, and TB7
6. Remove the Control Interface Board. Refer to Removing the Control Interface Board in this chapter.
7. Remove the two screws fastening the Standard Adapter Board to the Control Board/Adapter Mounting Plate.
8. Pull the Standard Adapter Board down to release it from the slide mounting stand-offs and connector J1.

Installation

Install the Standard Adapter Board in reverse order of removal.



ATTENTION: Replace all guards and insulators before applying power to the drive. Failure to replace guards may result in death or serious injury.

Removing the PLC Comm Adapter Board

Figure 2.7
PLC Comm Adapter Board

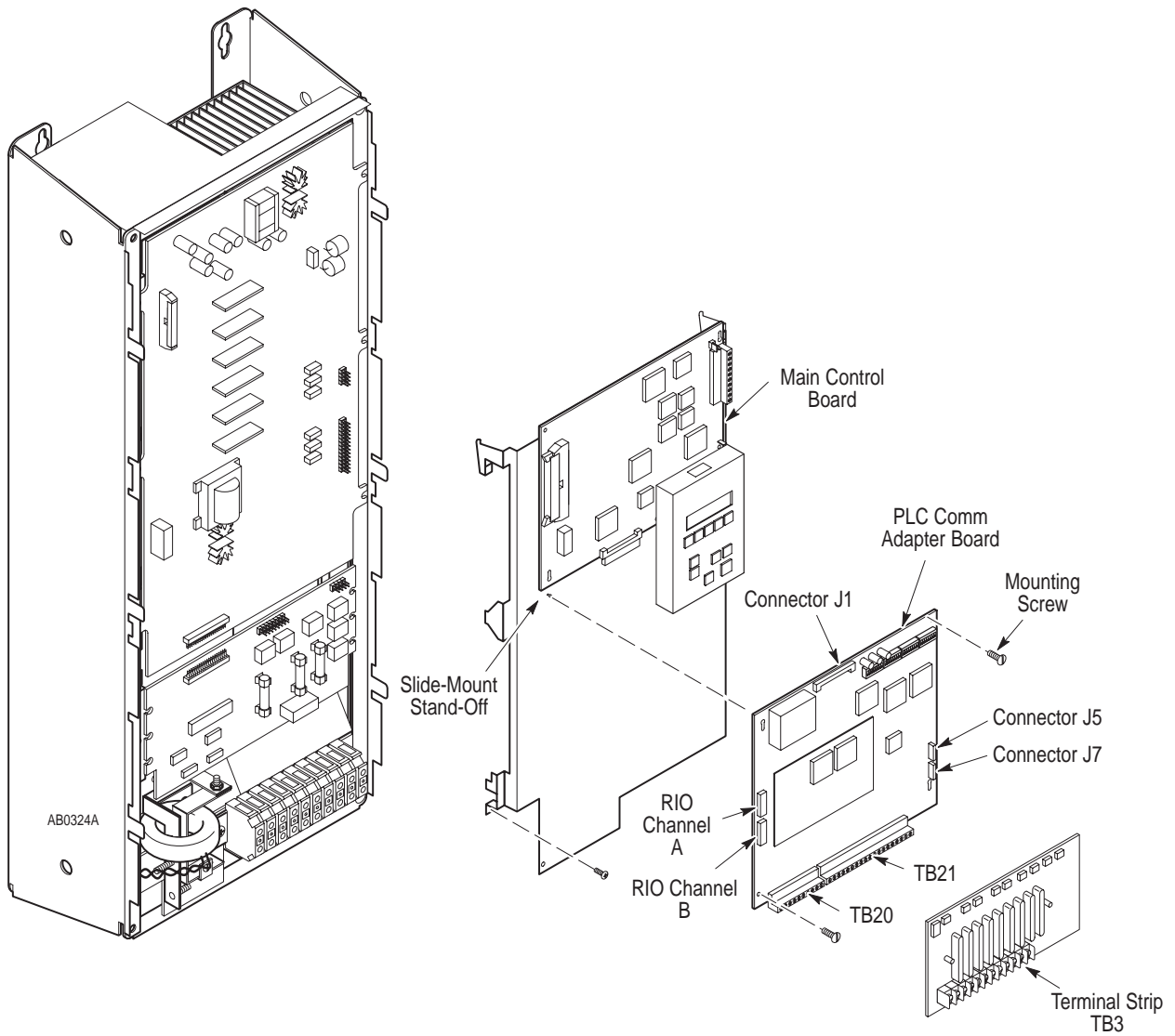

AB0584A

Removal



ATTENTION: Disconnect and lock out power from the drive before disassembling the drive. Failure to disconnect power may result in death or serious injury. Verify bus voltage by measuring the voltage between +DC and –DC on Terminal Block TB1. Do not attempt to service the drive until the bus voltage has discharged to zero volts.

1. Remove power from the Drive.
2. Open the Enclosure Cover. Refer to Opening the Drive Enclosure in this chapter.
3. Check for zero volts at TB1 Terminals +DC and –DC.
4. Check for the absence of control voltage at TB20 and TB21 on the PLC Comm Adapter Board.
5. Disconnect the following from the PLC Comm Adapter Board:
 - All wires from TB20 and TB21
 - Stake-on ground wire conductor
 - J5 connector
 - J7 connector
 - Communication channel A and B connectors
6. Remove the screws fastening the PLC Comm Adapter Board to the Control Board/Adapter Mounting Plate.
7. Pull the PLC Comm Adapter Board down to release it from the slide-mount stand-offs and connector J1.

Installation

Install the PLC Comm Adapter Board in reverse order of removal.



ATTENTION: Replace all guards and insulators before applying power to the drive. Failure to replace guards may result in death or serious injury.

Removing the Control Board/Adapter Mounting Plate

Figure 2.8
Control Board/Adapter Mounting Plate

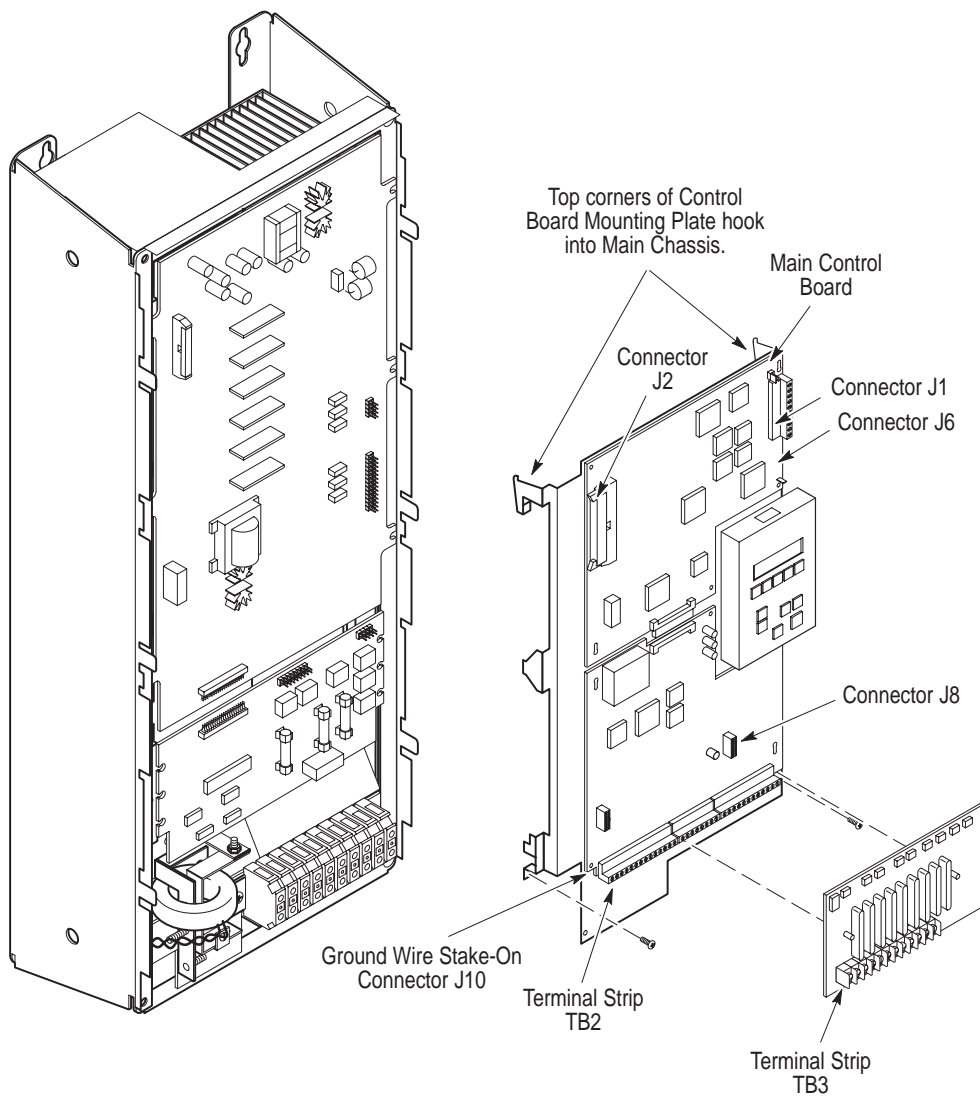

AB0585A

Removal



ATTENTION: Disconnect and lock out power from the drive before disassembling the drive. Failure to disconnect power may result in death or serious injury. Verify bus voltage by measuring the voltage between +DC and -DC on Terminal Block TB1. Do not attempt to service the drive until the bus voltage has discharged to zero volts.



ATTENTION: Wear a wrist-type grounding strap when servicing 1336 FORCE Drives. Failure to protect drive components against ESD may damage drive components. Refer to Electrostatic Discharge Precautions at the beginning of this chapter.

Important: Before you remove connections and wires from the drive components, mark the connections and wires to correspond with their component connections and terminals to prevent incorrect wiring during assembly.

1. Remove power from the drive.
2. Open the Enclosure Cover if the drive has an enclosure. Refer to Opening the Drive Enclosure in this chapter.
3. Check for zero volts at TB1 terminals +DC and -DC.
4. Check for absence of control voltage at:
 - TB20 and TB21 on drives using a PLC Comm Adapter Board
 - TB5, TB6, and TB7 on drives using a Standard Adapter Board
5. Remove the wires and connectors from the Standard or PLC Comm Adapter Board.



This drive may have either a standard Adapter Board or a PLC Comm Adapter Board. Refer to Removing the Standard Adapter Board or Removing the PLC Comm Adapter Board in this chapter.

6. Remove the wires and connectors from the Main Control Board.
7. Loosen the two captive screws near the bottom of the Control Board/Adapter Mounting Plate.
8. Pull the Control Board/Adapter Mounting Plate out about two inches, then slide it downward.

Installation

Install the Control Board/Adapter Mounting Plate in reverse order of removal.



ATTENTION: Replace all guards and insulators before applying power to the drive. Failure to replace guards may result in death or serious injury.

Removing the Precharge Board

Figure 2.9
Precharge Board

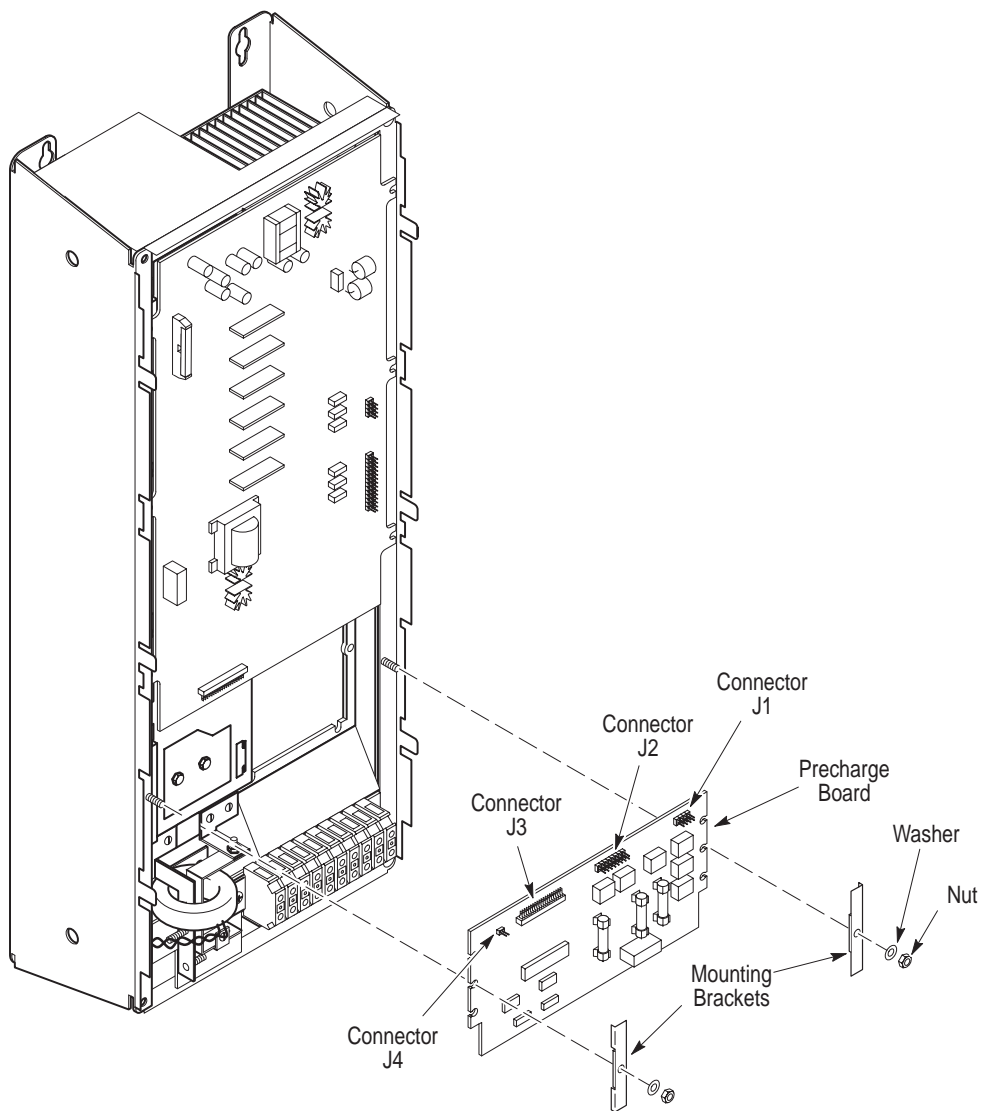

AB0327A

Removal



ATTENTION: Disconnect and lock out power from the drive before disassembling the drive. Failure to disconnect power may result in death or serious injury. Verify bus voltage by measuring the voltage between +DC and -DC on Terminal Block TB1. Do not attempt to service the drive until the bus voltage has discharged to zero volts.



ATTENTION: Wear a wrist-type grounding strap when servicing 1336 FORCE Drives. Failure to protect drive components against ESD may damage drive components. Refer to Electrostatic Discharge Precautions at the beginning of this chapter.

Important: Before you remove connections and wires from the drive components, mark the connections and wires to correspond with their component connections and terminals to prevent incorrect wiring during assembly.

1. Remove power from the drive.
2. Open the Enclosure if the drive has an Enclosure. Refer to Opening the Drive Enclosure in this chapter.
3. Check for zero volts at TB1 terminals +DC and -DC.
4. Check for absence of control voltage at:
 - TB20 and TB21 on drives using a PLC Comm Adapter Board
 - TB5, TB6, and TB7 on drives using a Standard Adapter Board
5. Disconnect the following from the Precharge Board:
 - J1 connector
 - J2 connector
 - J3 connector
 - J4 connector
6. Remove the nuts and brackets fastening the sides of the Precharge Board to the drive.

Installation

Install the Precharge Board in reverse order of removal.



ATTENTION: When removing the entire wire harness connecting Gate Driver Board connector J9 to Precharge Board connector J3, align the wires on the harness terminals with the pins on the board connectors. Incorrect harness connection may result in faulty drive operation and may damage the equipment.



ATTENTION: Replace all guards and insulators before applying power to the drive. Failure to replace guards may result in death or serious injury.

Removing the Gate Driver Board

Figure 2.10
Gate Driver Board

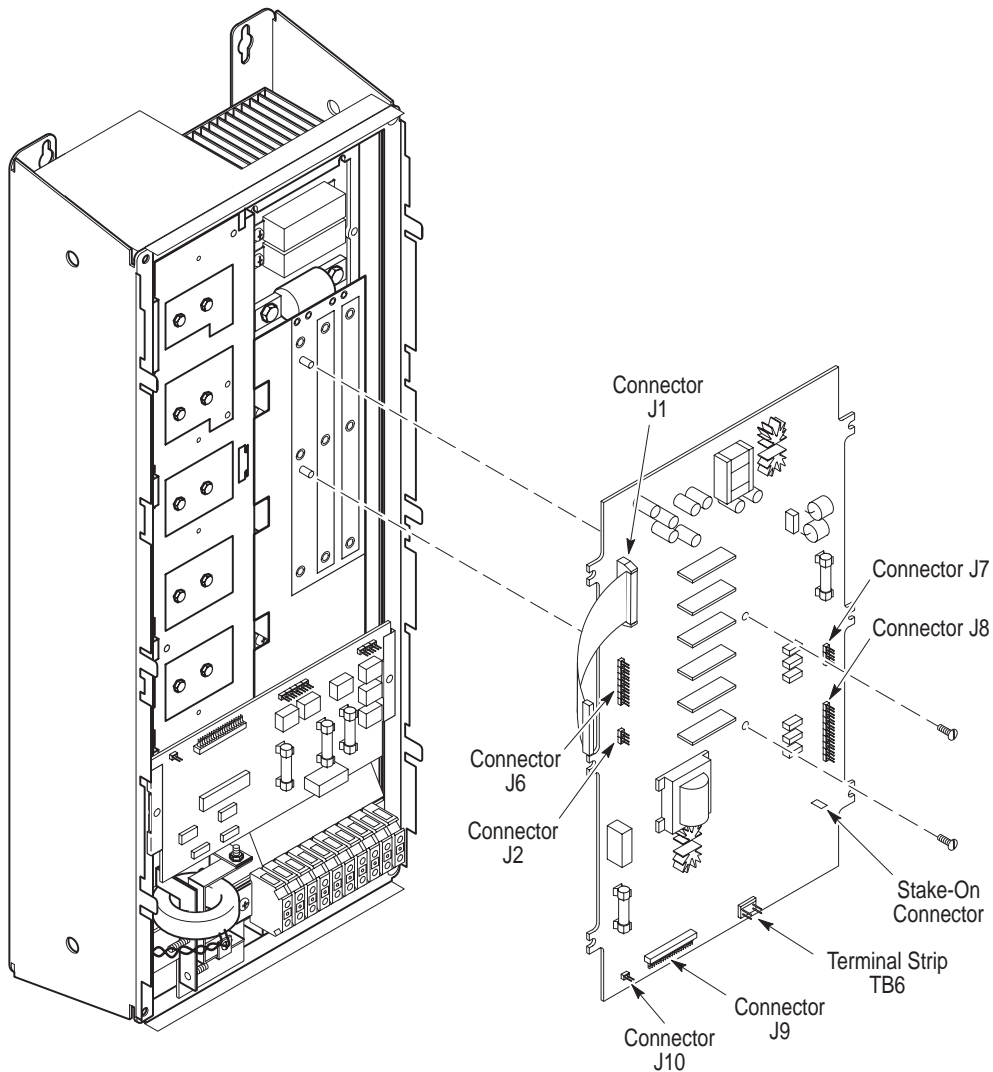

AB0341A

Removal



ATTENTION: Disconnect and lock out power from the drive before disassembling the drive. Failure to disconnect power may result in death or serious injury. Verify bus voltage by measuring the voltage between +DC and -DC on Terminal Block TB1. Do not attempt to service the drive until the bus voltage has discharged to zero volts.



ATTENTION: Wear a wrist-type grounding strap when servicing 1336 FORCE Drives. Failure to protect drive components against ESD may damage drive components. Refer to Electrostatic Discharge Precautions at the beginning of this chapter.

Important: Before you remove connections and wires from the drive components, mark the connections and wires to correspond with their component connections and terminals to prevent incorrect wiring during assembly.

1. Remove power from the drive.
2. Open the Enclosure if the drive has an Enclosure. Refer to Opening the Drive Enclosure in this chapter.
3. Check for zero volts at TB1 terminals +DC and -DC.
4. Check for absence of control voltage at:
 - TB20 and TB21 on drives using a PLC Comm Adapter Board
 - TB5, TB6, and TB7 on drives using a Standard Adapter Board
5. Remove the Control Board/Adapter Mounting Plate. Refer to Removing the Control Board/Adapter Mounting Plate in this chapter.
6. Disconnect the following from the Gate Driver Board:
 - J9 Precharge Board connector
 - J10 Bus Capacitor Bank connector
 - J2 Ground Sense CT connector
 - J7 Transistor Module connector
 - J8 Transistor Module connector
 - J6 Snubber Board connector
 - TB6 Fan connector
 - J13 connector
 - Ground wire from TB7
7. Remove the screws, fastening the Gate Driver Board to the drive, to remove the board from the drive.

Installation

Install the Gate Driver Board in reverse order of removal. Refer to Table 2.A – Fastener Torque Specifications.



ATTENTION: Replace all guards and insulators before applying power to the drive. Failure to replace guards may result in death or serious injury.

Removing the Snubber Board

Figure 2.11
Snubber Board

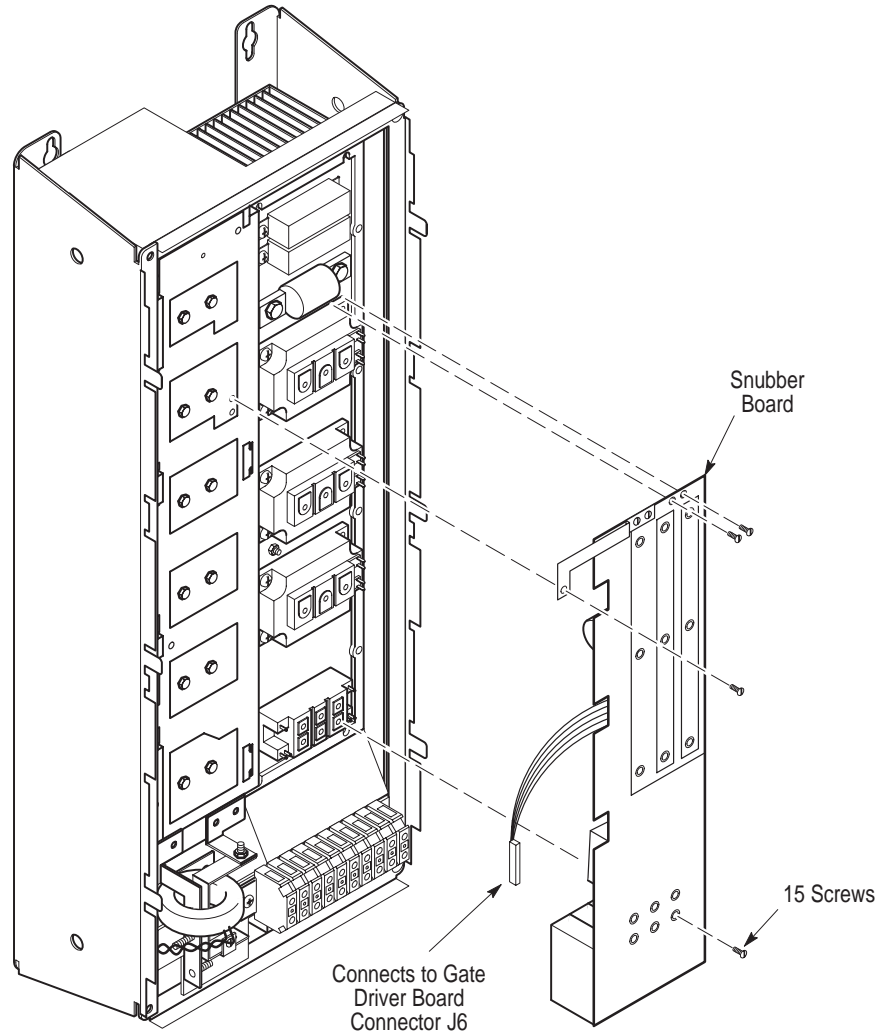

AB0343A

Removal



ATTENTION: Disconnect and lock out power from the drive before disassembling the drive. Failure to disconnect power may result in death or serious injury. Verify bus voltage by measuring the voltage between +DC and –DC on Terminal Block TB1. Do not attempt to service the drive until the bus voltage has discharged to zero volts.



ATTENTION: Wear a wrist-type grounding strap when servicing 1336 FORCE Drives. Failure to protect drive components against ESD may damage drive components. Refer to Electrostatic Discharge Precautions at the beginning of this chapter.

Important: Before you remove connections and wires from the drive components, mark the connections and wires to correspond with their component connections and terminals to prevent incorrect wiring during assembly.

1. Remove power from the drive.
2. Open the Enclosure if the drive has an Enclosure. Refer to Opening the Drive Enclosure in this chapter.
3. Check for zero volts at TB1 terminals +DC and –DC.
4. Check for absence of control voltage at:
 - TB20 and TB21 on drives using a PLC Comm Adapter Board
 - TB5, TB6, and TB7 on drives using a Standard Adapter Board
5. Remove the Gate Driver Board. Refer to Removing the Gate Driver Board in this chapter.
6. Remove the Precharge Board. Refer to Removing the Precharge Board in this chapter.
7. Remove the screws fastening the Snubber Board bus bar to the Bus Capacitor Bank.
8. Remove the wires from the Snubber Board stake-on connectors.
9. Remove the 15 screws fastening the Snubber Board to the Transistor Modules and Input Rectifier.



ATTENTION: The wire from TB1 terminal T3 (W) passes through the lower LEM located on the back of the Snubber Board. The wire from TB1 terminal T1 (U) passes through the upper LEM located on the back of the Snubber Board. During assembly, pass these wires through their respective LEMs to prevent damage to the equipment.

Installation

1. Remove the screws and nuts fastening the negative (-) bus bar to the old Snubber Board.
 2. Fasten the bus bar to the new Snubber Board.
 3. Pass the wires from TB1 terminals T3 (W) and T1 (U) through their respective LEMs.
-



ATTENTION: The wire from TB1 terminal T3 (W) passes through the lower LEM located on the back of the Snubber Board. The wire from TB1 terminal T1 (U) passes through the upper LEM located on the back of the Snubber Board. During assembly, pass these wires through their respective LEMs to prevent damage to the equipment.

4. Align the screw holes in the Snubber Board with the holes on the Transistor Modules and Input Rectifier.
 5. Install the Snubber Board in reverse order of removal.
-



ATTENTION: Replace all guards and insulators before applying power to the drive. Failure to replace guards may result in death or serious injury.

Accessing Chassis Power Components

To access the power components located on the chassis, refer to Removing the Gate Driver Board in this chapter.

This Page Intentionally Left Blank

Component Test Procedures

Chapter Objectives

The following tests help you troubleshoot A020-A030, B040, B050, BX040, BX060, and C025 – C060 drives.

Component Test Overview

In some cases, different tests troubleshoot components of the same name. These similar tests vary according to the rating of the drive being tested. Verify that the rating on the drive matches the rating for the test you are performing.

The procedures in this chapter assume that the drive you are servicing either has no enclosure or that the enclosure is open. For more information on opening the Drive Enclosure, refer to Chapter 2 – Disassembly and Access Procedures, Opening the Drive Enclosure.



ATTENTION: Some printed circuit boards and drive components may contain hazardous voltage levels. Remove and lock out power before you disconnect or reconnect wires, and before you remove or replace fuses and circuit boards. Verify bus voltage by measuring the voltage between +DC and –DC on Terminal Block TB1. Do not attempt to service the drive until the bus voltage has discharged to zero volts.



ATTENTION: Servicing energized industrial control equipment can be hazardous. Electrical shock, burns, or unintentional actuation of controlled industrial equipment may cause death or serious injury. Follow the safety-related practices of NFPA 70E, Electrical Safety for Employee Workplaces, when working on or near energized equipment. Do not work alone on energized equipment.

Electrostatic Discharge Precautions



ATTENTION: This assembly contains parts and sub-assemblies that are sensitive to electrostatic discharge. Static control precautions are required when servicing this assembly. Component damage may result if you ignore electrostatic discharge control procedures. If you are not familiar with static control procedures, reference Allen-Bradley Publication 8000-4.5.2, Guarding Against Electrostatic Discharge, or any other applicable ESD protection handbook.

Electrostatic discharge generated by static electricity can damage the complimentary metallic oxide semiconductor devices on various drive boards. It is recommended that you perform these procedures to guard against this type of damage when circuit boards are removed or installed:

- Wear a wrist-type grounding strap that is grounded to the chassis.
- Attach the wrist strap before removing the new circuit board from the conductive packet.
- Remove boards from the drive and immediately insert them into their conductive packets.

Tools

You need the following tools to disassemble and assemble the drive:

- Pliers
- Phillips screwdriver
- Standard screwdriver
- 5/16-inch or 8 mm socket
- 11/16-inch or 17 mm socket
- 5/16-inch or 8 mm open-end wrench
- Torque wrench, metered in lb-in. or N-m

Test 1 Testing Input Rectifier SCR1

Input Rectifier SCR1 is located on the bottom of the heat sink.

Figure 3.1
Input Rectifier Test

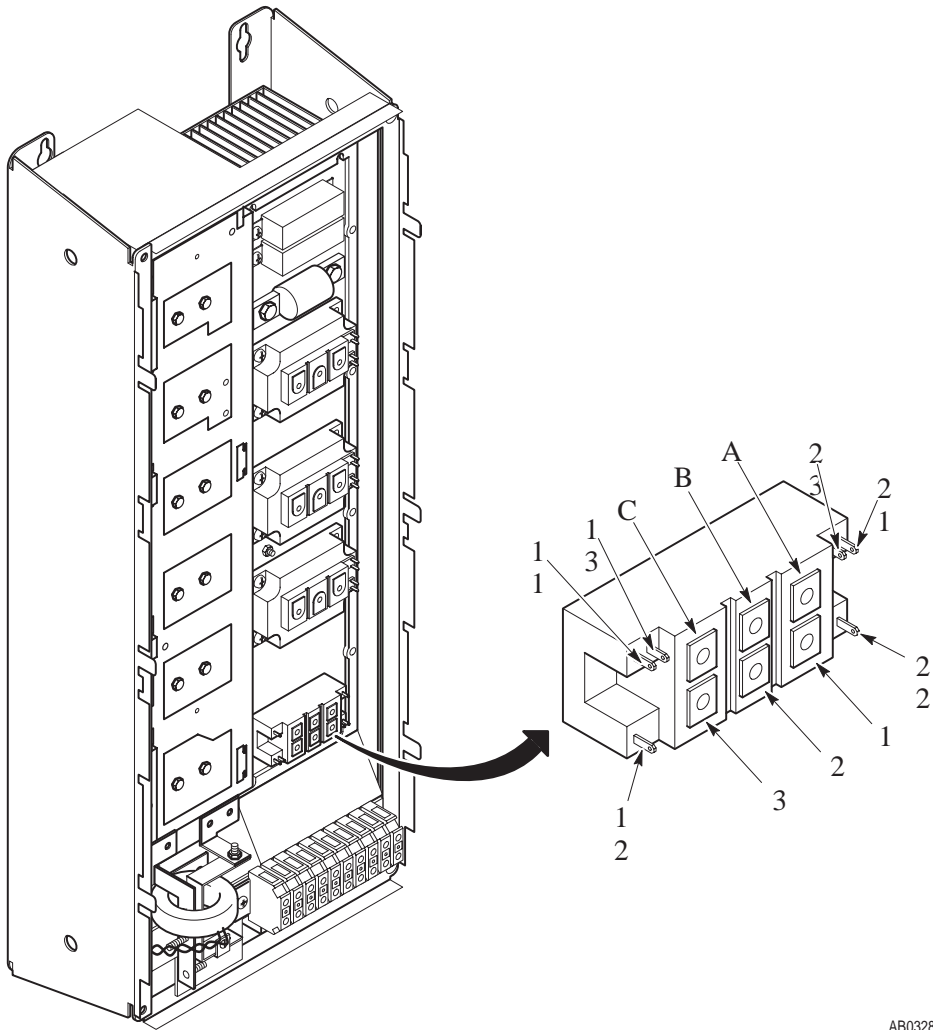

AB0328B



ATTENTION: Disconnect and lock out power from the drive before disassembling the drive. Failure to disconnect power may result in death or serious injury. Verify bus voltage by measuring the voltage between +DC and -DC on Terminal Block TB1. Do not attempt to service the drive until the bus voltage has discharged to zero volts.

Important: Before you remove connections and wires from the drive components, mark the connections and wires to correspond with their component connections and terminals to prevent incorrect wiring during assembly.

1. Remove power from the drive.
2. Check for zero volts at TB1 terminals +DC and –DC.
3. Check for absence of control voltage at:
 - TB20 and TB21 on drives using a PLC Comm Adapter Board
 - TB5, TB6, and TB7 on drives using a Standard Adapter Board
4. Remove the Snubber Board. Refer to Chapter 2 – Disassembly and Access Procedures, Removing the Snubber Board.
5. Set your meter to test diodes.
6. The following table shows meter connections and ideal meter readings for those connections. Refer to the former illustration for meter connection locations.

Table 3.A
Input Rectifier SCR1 Test

| Meter (+) Lead | Meter (-) Lead | Nominal Diode Reading | Nominal Ohm Reading |
|----------------|----------------|-----------------------|---------------------|
| 1 | A | Infinite | 8 Meg |
| 1 | B | Infinite | 8 Meg |
| 1 | C | Infinite | 8 Meg |
| 2 | A | Infinite | 8.5 Meg |
| 2 | B | Infinite | 8.5 Meg |
| 2 | C | Infinite | 8.5 Meg |
| 3 | A | Infinite | 7 Meg |
| 3 | B | Infinite | 7 Meg |
| 3 | C | Infinite | 7 Meg |
| 21 | 22 | 0.035 | 30 |
| 21 | 23 | 0.035 | 25 |
| 22 | 21 | 0.035 | 30 |
| 23 | 21 | 0.035 | 30 |
| 11 | 12 | Infinite | 10.5 Meg |
| 11 | 13 | Infinite | 10.5 Meg |
| 12 | 11 | Infinite | 10.5 Meg |
| 13 | 11 | Infinite | 10.5 Meg |

7. Replace the Input Rectifier if any meter readings are not as shown. Refer to Chapter 4 – Part Replacement Procedures, Input Rectifier SCR1.
8. If the Input Rectifier requires replacement, check the Power Modules for damage. Refer to Testing the Power Modules in this chapter.
9. Assemble the drive in reverse order of disassembly.

Test 2 Testing the Bus Capacitor Bank

The Bus Capacitor Bank is located on the left side of the Main Chassis.

Figure 3.2
Bus Capacitor Bank Test

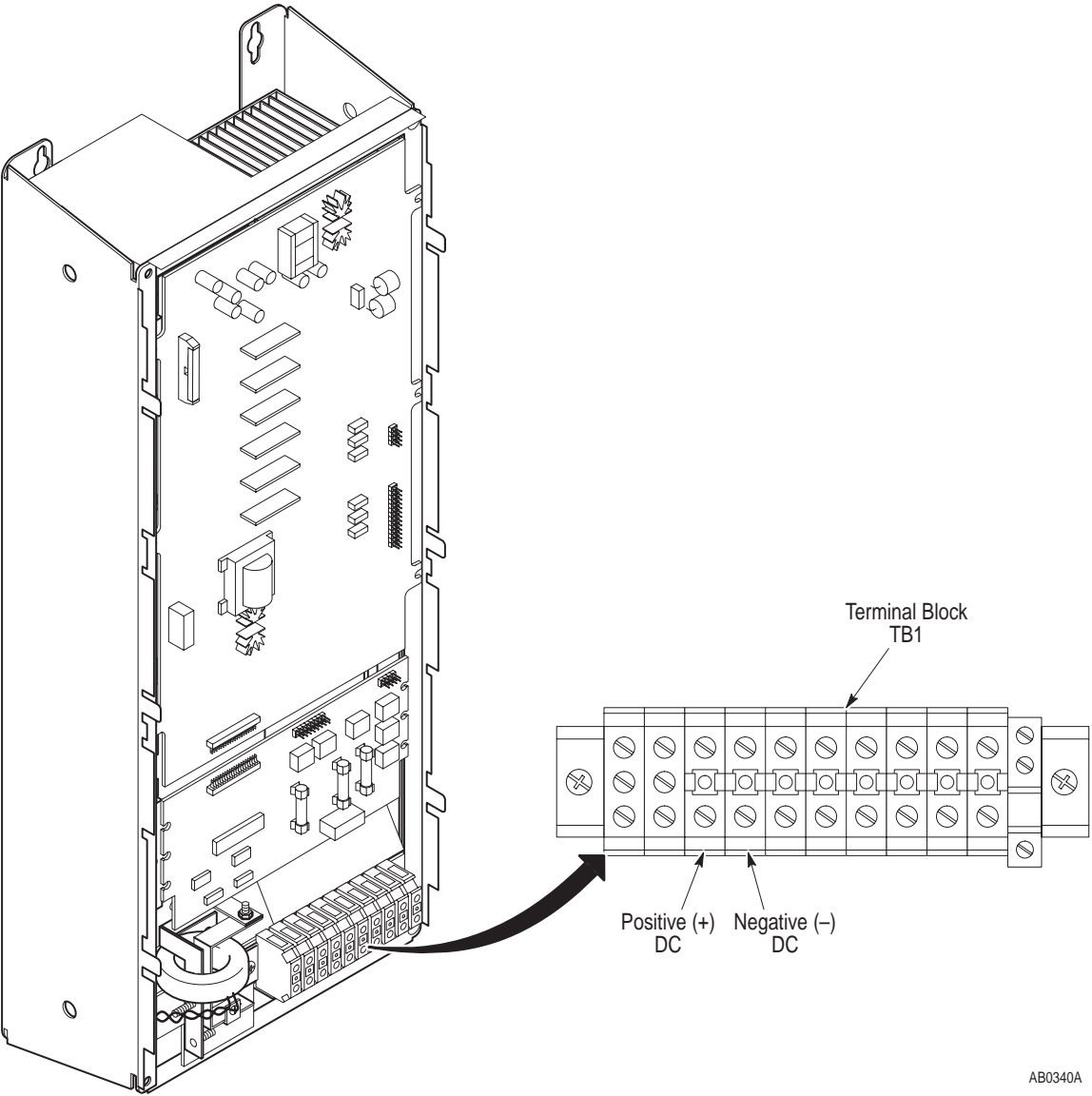

AB0340A



ATTENTION: Disconnect and lock out power from the drive before disassembling the drive. Failure to disconnect power may result in death or serious injury. Verify bus voltage by measuring the voltage between +DC and -DC on Terminal Block TB1. Do not attempt to service the drive until the bus voltage has discharged to zero volts.

Important: Before you remove connections and wires from the drive components, mark the connections and wires to correspond with their component connections and terminals to prevent incorrect wiring during assembly.

1. Remove power from the drive.
2. Check for zero volts at TB1 terminals +DC and –DC.
3. Check for absence of control voltage at:
 - TB20 and TB21 on drives using a PLC Comm Adapter Board
 - TB5, TB6, and TB7 on drives using a Standard Adapter Board
4. Set your meter to test voltage.
5. Connect the negative (–) lead of your meter to the (–) DC Bus terminal on TB1 and the positive lead to the (+) DC Bus terminal. Refer to the following tables and former illustration for meter readings and terminal locations.



ATTENTION: Servicing energized industrial control equipment can be hazardous. Electrical shock, burns, or unintentional actuation of controlled industrial equipment may cause death or serious injury. Follow the safety-related practices of NFPA 70E, Electrical Safety for Employee Workplaces, when working on or near energized equipment. Do not work alone on energized equipment.

6. Apply power **AFTER** the meter is connected, otherwise your meter will read zero volts. Expand readings for all input voltage ratings.

Table 3.B
Bus Capacitor Bank Test

| Drive Rating | Input Volts | Meter Reading |
|--------------|-------------|---------------|
| A | 200 | 280V DC +/-5% |
| | 230 | 322V DC +/-5% |
| | 240 | 336V DC +/-5% |
| B | 380 | 535V DC +/-5% |
| | 415 | 580V DC +/-5% |
| | 480 | 675V DC +/-5% |
| C | 500 | 700V DC +/-5% |
| | 575 | 810V DC +/-5% |
| | 600 | 850V DC +/-5% |

7. If the voltage is out of tolerance, check the following:
 - An open condition at Input Rectifier SCR1.
 - A voltage drop due to Bus Inductor L1 resistance.
 - A voltage drop between Input Rectifier SCR1 and the bus capacitors due to loose or resistive wires or connections.
 - Precharge circuit problems.
8. If the above check does not reveal a problem, replace the Bus Capacitor Bank and Load-Sharing Resistors. Refer to Chapter 4 – Part Replacement Procedures, Bus Capacitor Bank.



ATTENTION: Replace all guards and insulators before applying power to the drive. Failure to replace guards may result in death or serious injury.

Test 3 Testing Power Modules PM1 – PM3

Power Modules PM1 – PM3 are located near the center of the heat sink.

Figure 3.3
Power Module Test

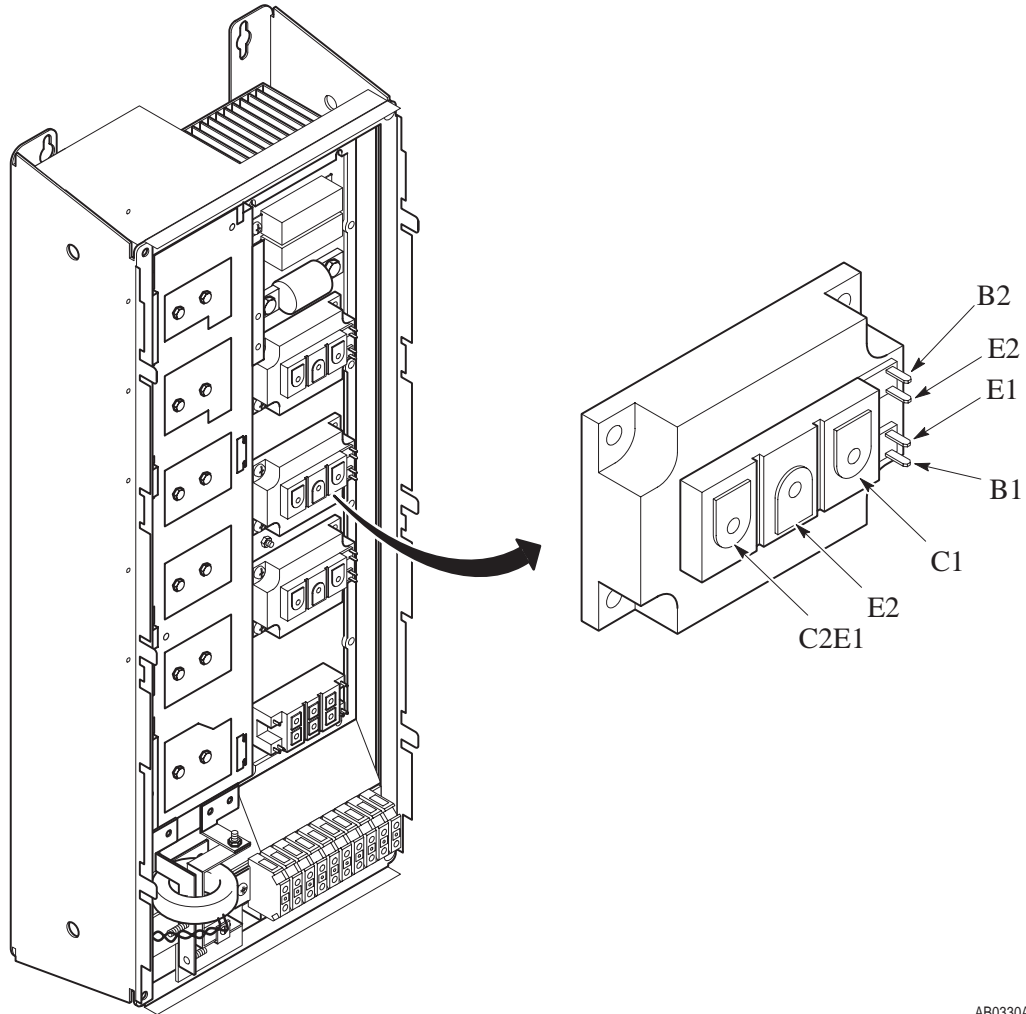

AB0330A



ATTENTION: Disconnect and lock out power from the drive before disassembling the drive. Failure to disconnect power may result in death or serious injury. Verify bus voltage by measuring the voltage between +DC and –DC on Terminal Block TB1. Do not attempt to service the drive until the bus voltage has discharged to zero volts.

Important: Before you remove connections and wires from the drive components, mark the connections and wires to correspond with their component connections and terminals to prevent incorrect wiring during assembly.

1. Remove power from the drive.
2. Check for zero volts at TB1 terminals +DC and –DC.
3. Check for absence of control voltage at:
 - TB20 and TB21 on drives using a PLC Comm Adapter Board
 - TB5, TB6, and TB7 on drives using a Standard Adapter Board
4. Remove the Snubber Board. Refer to Chapter 2 – Disassembly and Access Procedures, Removing the Snubber Board.
5. Set your meter to test diodes.
6. Test Power Modules PM1, PM2, and PM3. The following table shows meter connections and ideal meter readings for those connections. Refer to the former illustration for meter connection locations.

Table 3.C
Power Modules PM1 – PM3

| Motor (+) Lead | Meter (-) Lead | Nominal Meter Reading |
|----------------|----------------|-----------------------|
| C2E1 | E2 | Infinite |
| E2 | C2E1 | 0.36 |
| C1 | C2E1 | Infinite |
| C2E1 | C1 | 0.36 |
| B1 | E1 | Infinite/Capacitive |
| B2 | E2 | Infinite/Capacitive |

7. Replace Power Module PM1, PM2, or PM3 if meter readings are not as shown. Refer to Chapter 4 – Part Replacement Procedures, Power Modules PM1 – PM3.
8. If one or more Power Modules is replaced, test the Gate Driver Board. Refer to Testing the Gate Driver Board in this chapter.
9. Assemble the drive in reverse order of disassembly.



ATTENTION: Replace all guards and insulators before applying power to the drive. Failure to replace guards may result in death or serious injury.

Test 4 Testing Bus Fuse F1

Bus Fuse F1 is located at the top of the heat sink.

Figure 3.4
Bus Fuse F1 Test

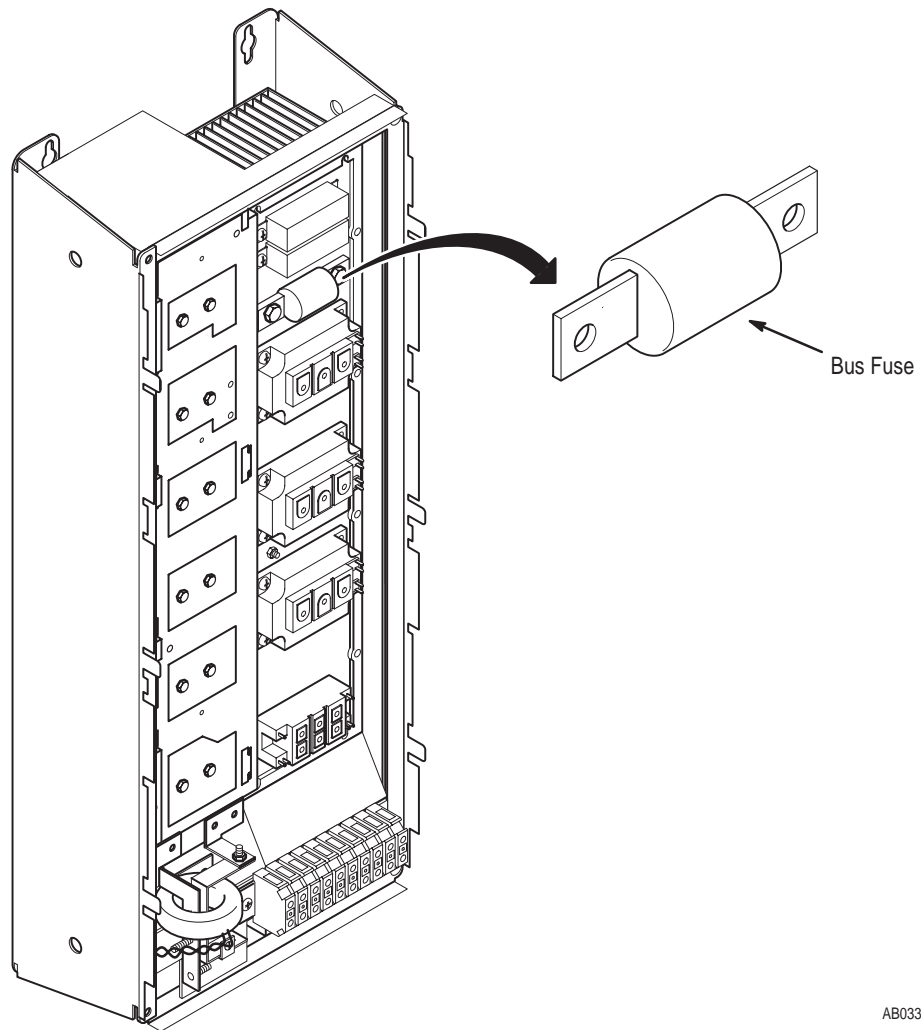

AB0331A



ATTENTION: Disconnect and lock out power from the drive before disassembling the drive. Failure to disconnect power may result in death or serious injury. Verify bus voltage by measuring the voltage between +DC and -DC on Terminal Block TB1. Do not attempt to service the drive until the bus voltage has discharged to zero volts.

Important: Before you remove connections and wires from the drive components, mark the connections and wires to correspond with their component connections and terminals to prevent incorrect wiring during assembly.

1. Remove power from the drive.
2. Check for zero volts at TB1 terminals +DC and –DC.
3. Check for absence of control voltage at:
 - TB20 and TB21 on drives using a PLC Comm Adapter Board
 - TB5, TB6, and TB7 on drives using a Standard Adapter Board
4. Remove the Gate Driver Board. Refer to Chapter 2 – Disassembly and Access Procedures, Removing the Gate Driver Board.
5. Set your meter to test resistance.
6. Check for an open condition across Bus Fuse F1.
7. If the fuse shows an open condition, replace the fuse. Refer to Chapter 4 – Part Replacement Procedures, Bus Fuse F1.
8. Assemble the drive in reverse order of disassembly.



ATTENTION: Replace all guards and insulators before applying power to the drive. Failure to replace guards may result in death or serious injury.

Test 5 Testing the Gate Driver Board

The Gate Driver Board is located between the Main Control Board and the Main Chassis. If one or more Power Modules has been replaced, you must test the Gate Driver Board.

Figure 3.5
Gate Driver Board Test

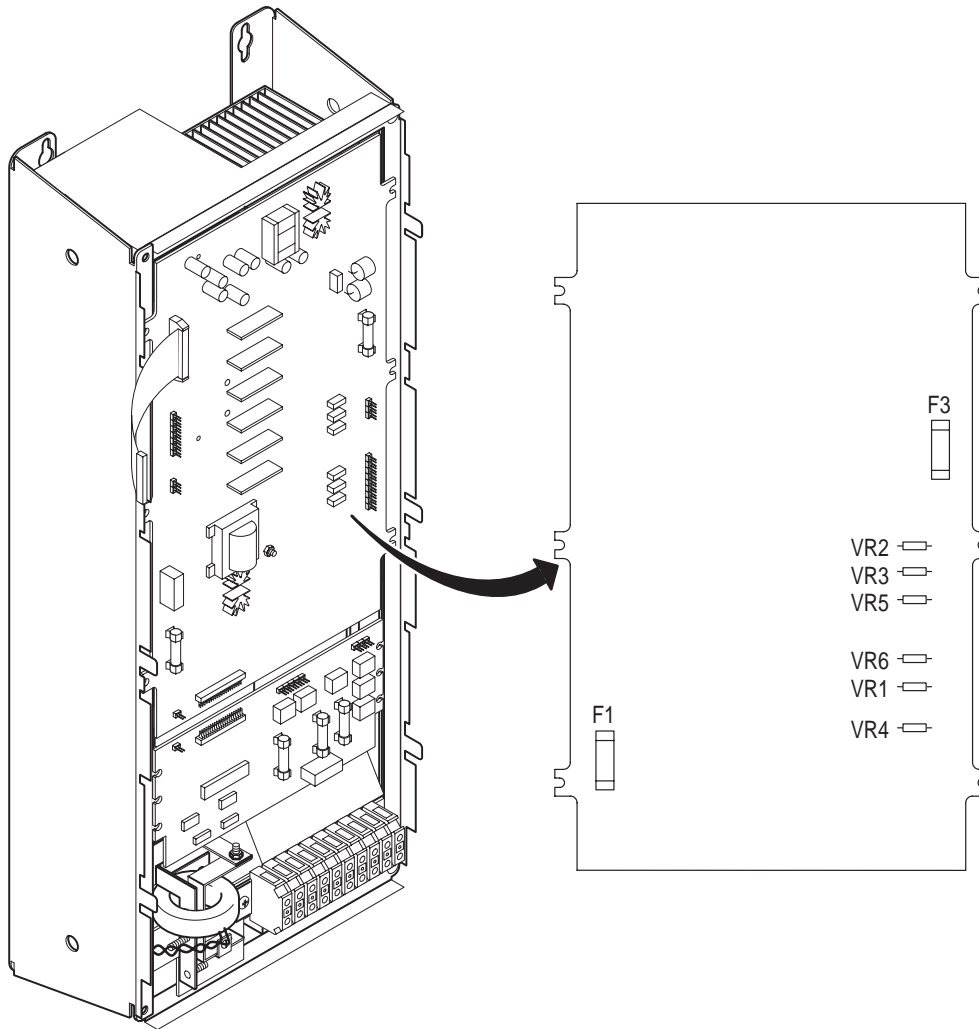

AB0339A



ATTENTION: Disconnect and lock out power from the drive before disassembling the drive. Failure to disconnect power may result in death or serious injury. Verify bus voltage by measuring the voltage between +DC and -DC on Terminal Block TB1. Do not attempt to service the drive until the bus voltage has discharged to zero volts.

Important: Before you remove connections and wires from the drive components, mark the connections and wires to correspond with their component connections and terminals to prevent incorrect wiring during assembly.

1. Remove power from the drive.
2. Check for zero volts at TB1 terminals +DC and –DC.
3. Check for absence of control voltage at:
 - TB20 and TB21 on drives using a PLC Comm Adapter Board
 - TB5, TB6, and TB7 on drives using a Standard Adapter Board
4. Remove the Control Board/Adapter Mounting Plate. Refer to Chapter 2 – Disassembly and Access Procedures, Removing the Control Board/Adapter Mounting Plate.
5. Unplug the connectors from the Gate Driver Board.
6. Set your meter to test resistance.
7. Test Fuses F1 and F3 for an open condition. Replace the Gate Driver Board if either fuse shows an open condition.
8. Set your meter to test diodes.
9. Test VR1 – VR6. The following table shows meter connections at the components and ideal meter readings for those connections. Refer to the former illustration for meter connection locations.

Table 3.D
Gate Driver Board Test

| Component | Meter (+) Lead | Meter (–) Lead | Nominal Meter Reading |
|-----------|----------------|----------------|-----------------------|
| VR1 – VR6 | + | – | 1.06 |
| | – | + | 1.8 |

NOTE: Typical malfunction is shorted in both directions.

10. Replace the Gate Driver Board if your readings do not match the table readings. Refer to Chapter 2 – Disassembly and Access Procedures, Removing the Gate Driver Board.
11. Assemble the drive in reverse order of disassembly.



ATTENTION: Replace all guards and insulators before applying power to the drive. Failure to replace guards may result in death or serious injury.

Test 6 Testing the Precharge Board

Figure 3.6
Precharge Board Test

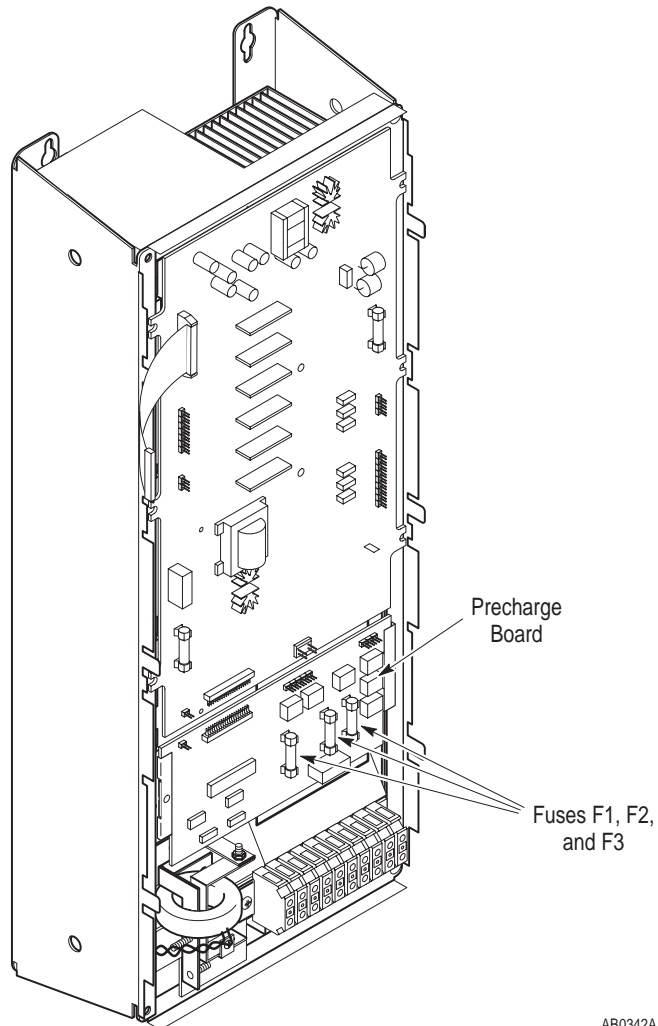

AB0342A



ATTENTION: Disconnect and lock out power from the drive before disassembling the drive. Failure to disconnect power may result in death or serious injury. Verify bus voltage by measuring the voltage between +DC and -DC on Terminal Block TB1. Do not attempt to service the drive until the bus voltage has discharged to zero volts.

Important: Before you remove connections and wires from the drive components, mark the connections and wires to correspond with their component connections and terminals to prevent incorrect wiring during assembly.

1. Remove power from the drive.
2. Check for zero volts at TB1 terminals +DC and -DC.
3. Check for absence of control voltage at:
 - TB20 and TB21 on drives using a PLC Comm Adapter Board
 - TB5, TB6, and TB7 on drives using a Standard Adapter Board
4. Set your meter to measure resistance.
5. Test fuses F1, F2, and F3 for open conditions.
6. Replace the Precharge Board if any fuse shows an open condition.

Test 7 Testing the Thermistor

Figure 3.7
Thermistor Test

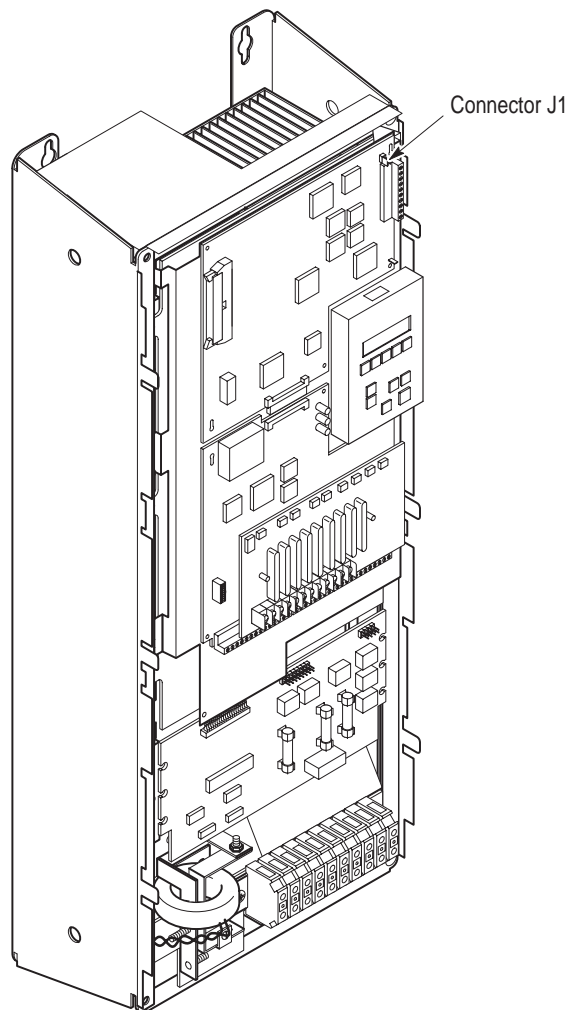

AB0593A



ATTENTION: Disconnect and lock out power from the drive before disassembling the drive. Failure to disconnect power may result in death or serious injury. Verify bus voltage by measuring the voltage between +DC and -DC on Terminal Block TB1. Do not attempt to service the drive until the bus voltage has discharged to zero volts.

Important: Before you remove connections and wires from the drive components, mark the connections and wires to correspond with their component connections and terminals to prevent incorrect wiring during assembly.

1. Remove power from the drive.
2. Check for zero volts at TB1 terminals +DC and -DC.
3. Check for absence of control voltage at:
 - TB20 and TB21 on drives using a PLC Comm Adapter Board
 - TB5, TB6, and TB7 on drives using a Standard Adapter Board
4. Disconnect the Thermistor from Connector J1 on the Main Control Board.
5. Allow the drive to cool down to room temperature.
6. Set your meter to test resistance.
7. Measure the resistance across the Thermistor wires. Nominal meter reading should be 100K ohms at room temperature.
8. If the Thermistor reading measures other than the nominal value, replace the Thermistor. Refer to Chapter 4 – Part Replacement Procedures, Thermistor.

This Page Intentionally Left Blank

Part Replacement Procedures

Chapter Objective

This chapter describes procedures required to replace drive components. This chapter references Chapter 2 – Disassembly and Access Procedures for basic drive component access.

Part Replacement Overview

The part replacement procedures in this chapter assume that the drive you are servicing either has no enclosure or that the enclosure is open. For more information on opening the Drive Enclosure, refer to Chapter 2 – Disassembly and Access Procedures, Opening the Drive Enclosure.

Safety Precautions



ATTENTION: Some printed circuit boards and drive components may contain hazardous voltage levels. Remove power before you disconnect or reconnect wires, and before you remove or replace fuses and circuit boards. Verify bus voltage by measuring the voltage between +DC and –DC on Terminal Block TB1. Do not attempt to service the drive until the bus voltage has discharged to zero volts.

Electrostatic Discharge Precautions



ATTENTION: This assembly contains parts and sub-assemblies that are sensitive to electrostatic discharge. Static control precautions are required when servicing this assembly. Component damage may result if you ignore electrostatic discharge control procedures. If you are not familiar with static control procedures, reference Allen-Bradley Publication 8000-4.5.2, Guarding Against Electrostatic Discharge, or any other applicable ESD protection handbook.

Electrostatic discharge generated by static electricity can damage the complimentary metallic oxide semiconductor devices on various drive boards. It is recommended that you perform these procedures to guard against this type of damage when circuit boards are removed or installed:

- Wear a wrist-type grounding strap that is grounded to the chassis.
- Attach the wrist strap before removing the new circuit board from the conductive packet.
- Remove boards from the drive and immediately insert them into their conductive packets.

Tools

You need the following tools to disassemble and assemble the drive:

- Pliers
- Phillips screwdriver
- Standard screwdriver
- 5/16-inch or 8 mm socket
- 11/16-inch or 17 mm socket
- 5/16-inch or 8 mm open-end wrench
- Torque wrench, metered in lb-in. or N-m

Major Component Replacement

This section explains in detail how to replace the following drive components:

- Ground Sense CT
- Bus Fuse F1
- Thermistor
- Power Modules PM1 – PM3
- Input Rectifier SCR1
- Fan
- DC Bus Inductor L1
- Bus Capacitors

For Gate Driver Board, Main Control Board, Standard Adapter Board, Precharge Board, PLC Comm Adapter Board, and Control Interface Board installation and removal procedures, refer to Chapter 2.

Detailed Product Identification

Allen-Bradley Adjustable Frequency AC Drives are modular by design to enhance troubleshooting and spare parts replacement, thereby helping reduce production down-time.

The following illustration calls out the main components of a typical drive. Component designs vary slightly among the different drive ratings, but component locations are identical.

Figure 4.1
Main Drive Components

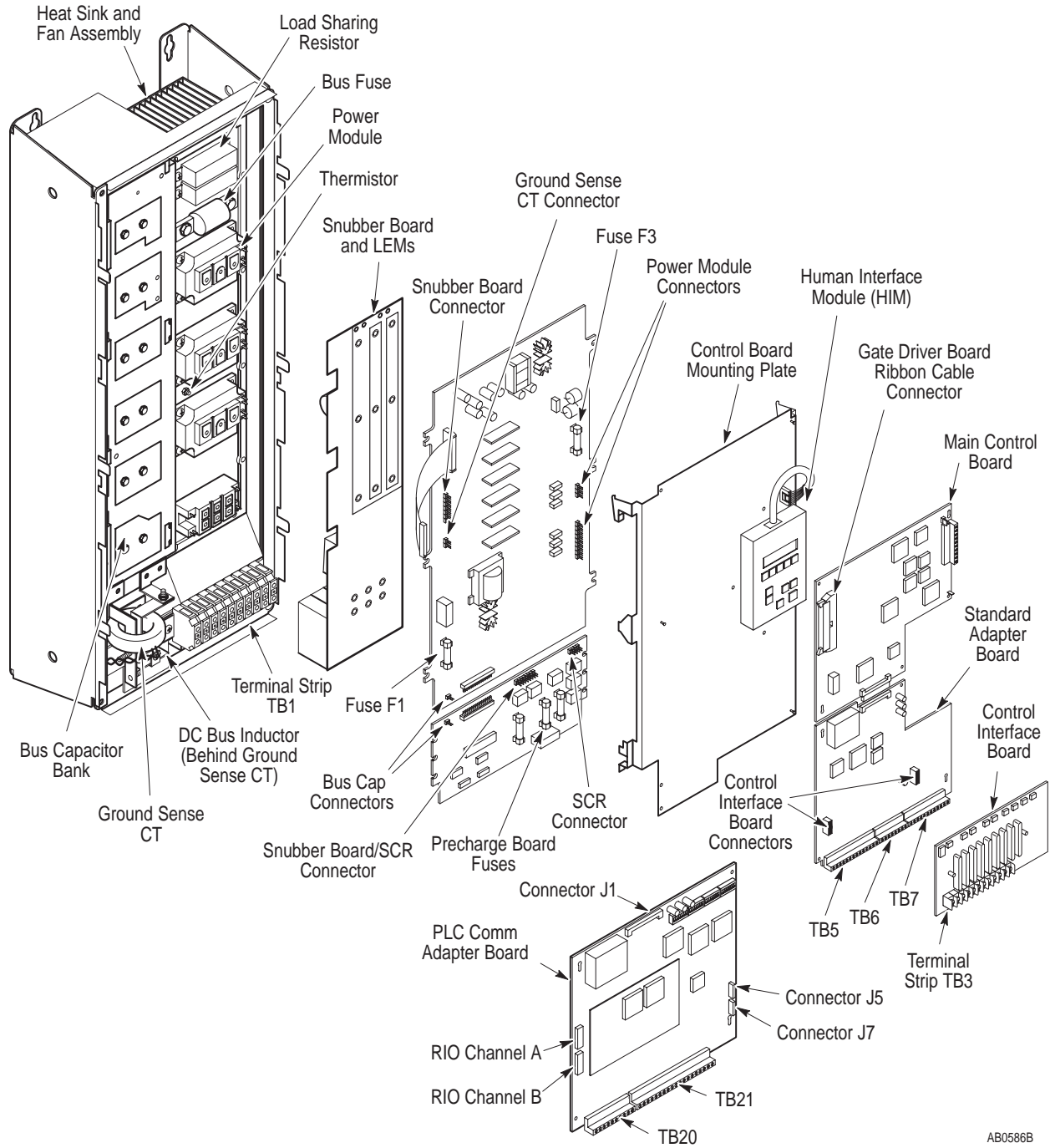

AB0586B

Ground Sense CT

The Ground Sense CT is located in the lower left corner of the drive.

Figure 4.2
Ground Sense CT

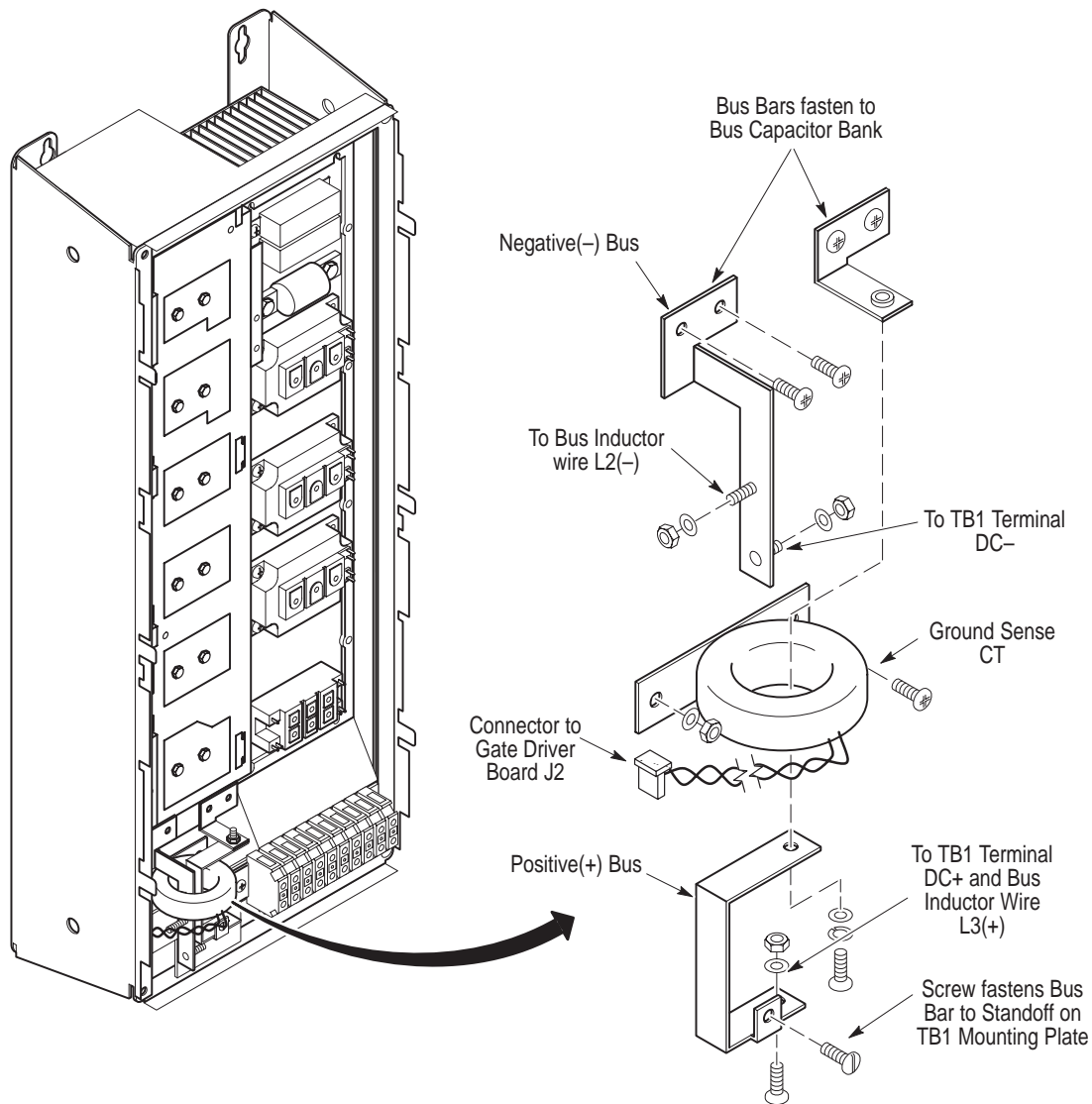

AB0348A

Removal



ATTENTION: Disconnect and lock out power from the drive before disassembling the drive. Failure to disconnect power may result in death or serious injury. Verify bus voltage by measuring the voltage between +DC and -DC on Terminal Block TB1. Do not attempt to service the drive until the bus voltage has discharged to zero volts.



ATTENTION: Wear a wrist-type grounding strap when servicing 1336 FORCE Drives. Failure to protect drive components against ESD may damage drive components. Refer to Electrostatic Discharge Precautions at the beginning of this chapter.

Important: Before you remove connections and wires from the drive components, mark the connections and wires to correspond with their component connections and terminals to prevent incorrect wiring during assembly.

1. Remove power from the drive.
2. Check for zero volts at TB1 terminals +DC and –DC.
3. Check for absence of control voltage at:
 - TB20 and TB21 on drives using a PLC Comm Adapter Board
 - TB5, TB6, and TB7 on drives using a Standard Adapter Board
4. Remove the Control Board/Adapter Mounting Plate. Refer to Chapter 2 – Disassembly and Access Procedures, Removing the Control Board/Adapter Mounting Plate.
5. Remove the Precharge Board. Refer to Chapter 2 – Disassembly and Access Procedures, Removing the Precharge Board.
6. Disconnect the Ground Sense CT from Gate Driver Board connector J2.
7. Remove the following from the Ground Sense CT Bus Bars:
 - DC Bus Inductor wire L3.
 - DC Bus Inductor wire L2. Note that the positive (+) and negative (–) DC wires from TB1 do not need to be removed from the bus bars.
 - The screw fastening the positive (+) bus bar to the standoff.
 - The screw and nut assembly fastening the positive (+) bus bar to the bus bar extension from Bus Capacitor Bank terminal E1.
 - The two screws fastening the negative (–) bus bar to the Bus Capacitor Bank terminal E2.
8. Remove the nut fastening the Ground Sense CT to the Main Chassis.
9. Remove the screw fastening the Ground Sense CT to the TB1 Mounting Plate.

Installation

1. Place the bus bars through the center of the Ground Sense CT.
2. Install the Ground Sense CT in reverse order of removal. Refer to Table 2.A – Fastener Torque Specifications.



ATTENTION: Replace all guards and insulators before applying power to the drive. Failure to replace guards may result in death or serious injury.

Bus Fuse F1

Bus Fuse F1 is located at the top of the heat sink.

Figure 4.3
Bus Fuse F1

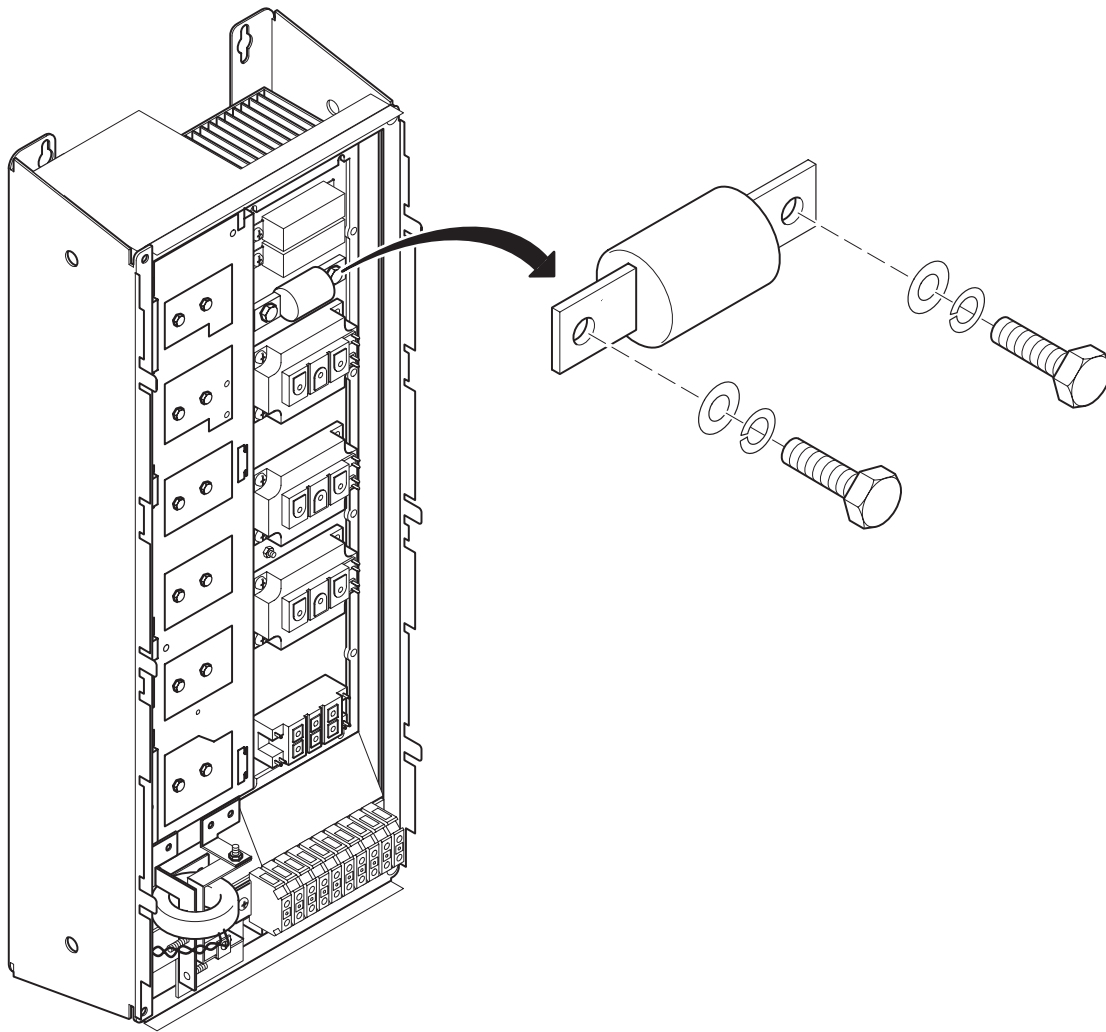

AB0332A

Removal



ATTENTION: Disconnect and lock out power from the drive before disassembling the drive. Failure to disconnect power may result in death or serious injury. Verify bus voltage by measuring the voltage between +DC and –DC on Terminal Block TB1. Do not attempt to service the drive until the bus voltage has discharged to zero volts.



ATTENTION: Wear a wrist-type grounding strap when servicing 1336 FORCE Drives. Failure to protect drive components against ESD may damage drive components. Refer to Electrostatic Discharge Precautions at the beginning of this chapter.

Important: Before you remove connections and wires from the drive components, mark the connections and wires to correspond with their component connections and terminals to prevent incorrect wiring during assembly.

1. Remove power from the drive.
2. Check for zero volts at TB1 terminals +DC and –DC.
3. Check for absence of control voltage at:
 - TB20 and TB21 on drives using a PLC Comm Adapter Board
 - TB5, TB6, and TB7 on drives using a Standard Adapter Board
4. Remove the Gate Driver Board. Refer to Chapter 2 – Disassembly and Access Procedures, Removing the Gate Driver Board.
5. Remove the two bolts fastening the fuse to the drive.

Installation

Install Fuse F1 in reverse order of removal. Refer to Table 2.A – Fastener Torque Specifications.



ATTENTION: Replace all guards and insulators before applying power to the drive. Failure to replace guards may result in death or serious injury.

Thermistor

The Thermistor is located on the heat sink, between the Power Modules and the Input Rectifier.

Figure 4.4
Thermistor

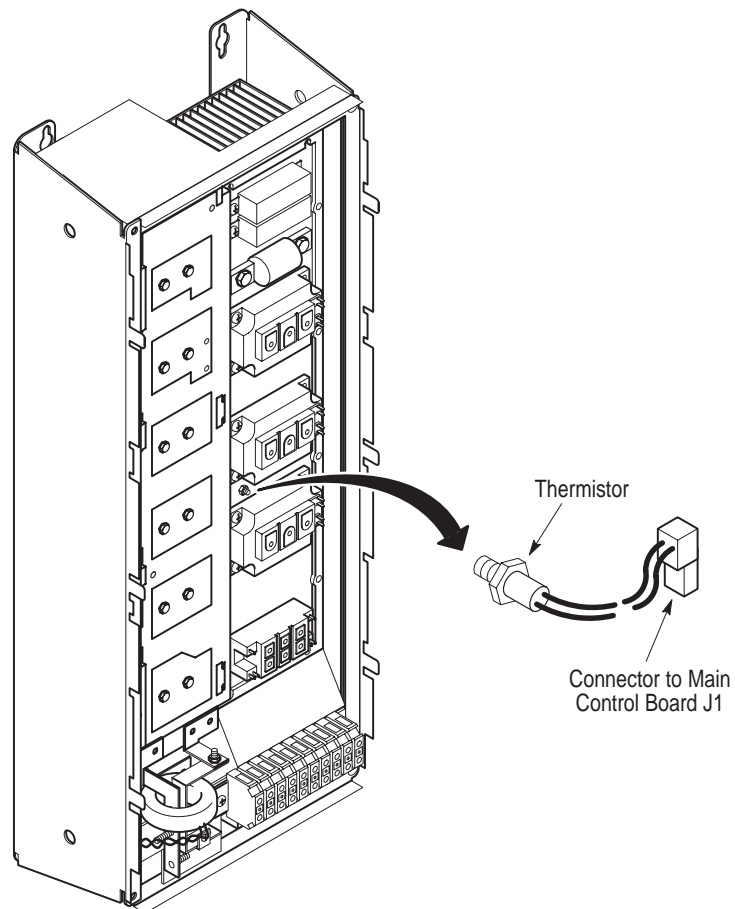

Removal



ATTENTION: Disconnect and lock out power from the drive before disassembling the drive. Failure to disconnect power may result in death or serious injury. Verify bus voltage by measuring the voltage between +DC and -DC on Terminal Block TB1. Do not attempt to service the drive until the bus voltage has discharged to zero volts.



ATTENTION: Wear a wrist-type grounding strap when servicing 1336 FORCE Drives. Failure to protect drive components against ESD may damage drive components. Refer to Electrostatic Discharge Precautions at the beginning of this chapter.

Important: Before you remove connections and wires from the drive components, mark the connections and wires to correspond with their component connections and terminals to prevent incorrect wiring during assembly.

1. Remove power from the drive.
2. Check for zero volts at TB1 terminals +DC and –DC.
3. Check for absence of control voltage at:
 - TB20 and TB21 on drives using a PLC Comm Adapter Board
 - TB5, TB6, and TB7 on drives using a Standard Adapter Board
4. Remove the Snubber Board from the drive. Refer to Chapter 2 – Disassembly and Access Procedures, Removing the Snubber Board.
5. Unscrew the Thermistor from the heat sink.

Installation

Install the Thermistor in reverse order of removal.

Important: When fastening the Thermistor to the heat sink, hand-tighten the Thermistor to avoid damaging the porcelain Thermistor body.



ATTENTION: Replace all guards and insulators before applying power to the drive. Failure to replace guards may result in death or serious injury.

Power Modules PM1 – PM3

Power Modules PM1 – PM3 are located on the heat sink, behind the Snubber Board.

Figure 4.5
Power Modules

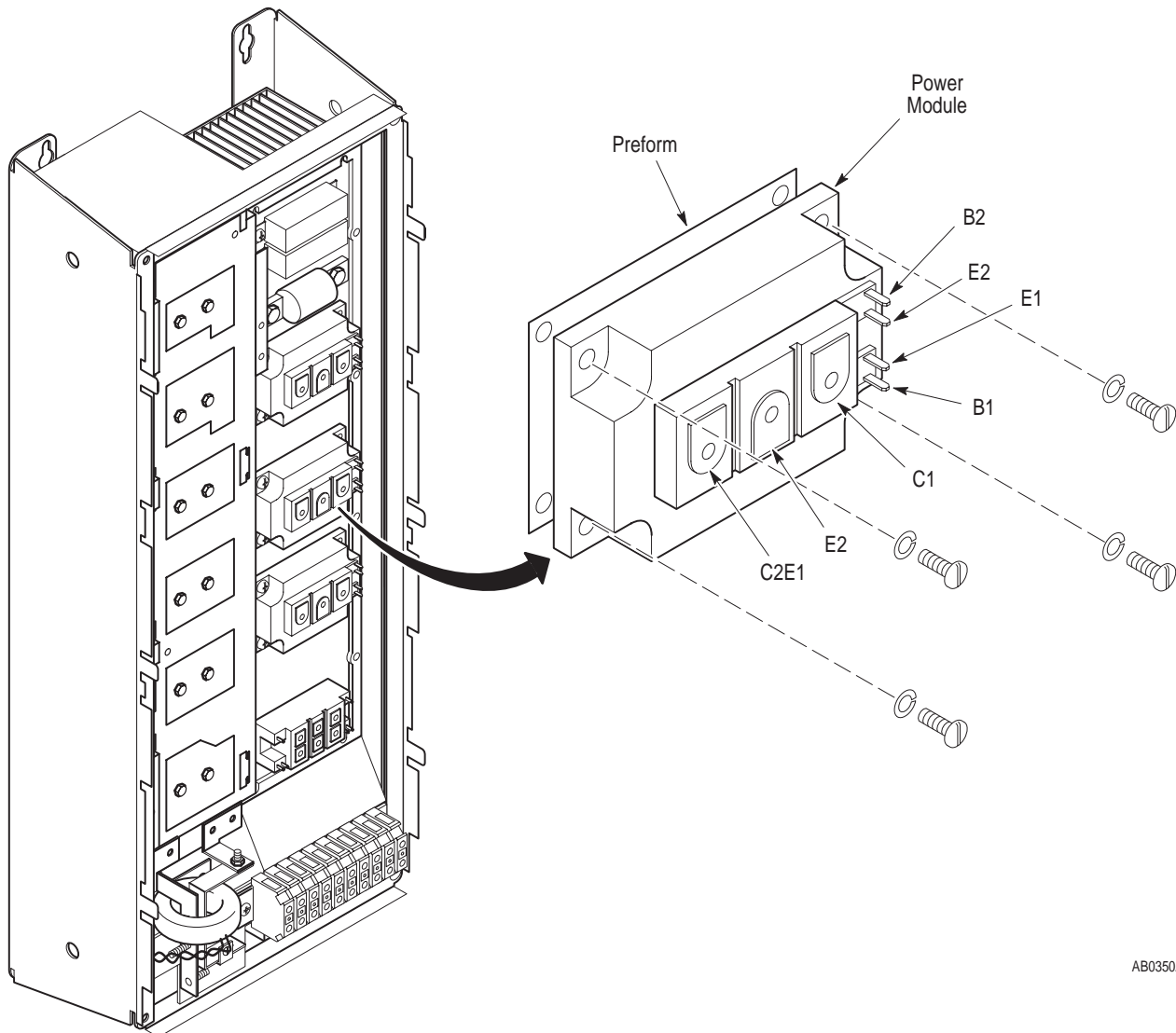

AB0350A

Removal



ATTENTION: Disconnect and lock out power from the drive before disassembling the drive. Failure to disconnect power may result in death or serious injury. Verify bus voltage by measuring the voltage between +DC and -DC on Terminal Block TB1. Do not attempt to service the drive until the bus voltage has discharged to zero volts.



ATTENTION: Wear a wrist-type grounding strap when servicing 1336 FORCE Drives. Failure to protect drive components against ESD may damage drive components. Refer to Electrostatic Discharge Precautions at the beginning of this chapter.

Important: Before you remove connections and wires from the drive components, mark the connections and wires to correspond with their component connections and terminals to prevent incorrect wiring during assembly.

1. Remove power from the drive.
2. Check for zero volts at TB1 terminals +DC and –DC.
3. Check for absence of control voltage at:
 - TB20 and TB21 on drives using a PLC Comm Adapter Board
 - TB5, TB6, and TB7 on drives using a Standard Adapter Board
4. Remove the Snubber Board from the drive. Refer to Chapter 2 – Disassembly and Access Procedures, Removing the Snubber Board.
5. Remove all wires connected to the Power Module terminals.
6. Remove the screws fastening the Power Module to the heat sink.

Installation

1. Clean all surfaces between the Power Module and the heat sink using a soft, clean cloth.
2. Replace the Preform between the Power Module and the heat sink.
3. Install the Power Module in reverse order of removal. Refer to Table 2.A – Fastener Torque Specifications.



ATTENTION: Replace all guards and insulators before applying power to the drive. Failure to replace guards may result in death or serious injury.

Input Rectifier SCR1

The Input Rectifier SCR1 is located on the heat sink, behind the Snubber Board.

Figure 4.6
Input Rectifier SCR1

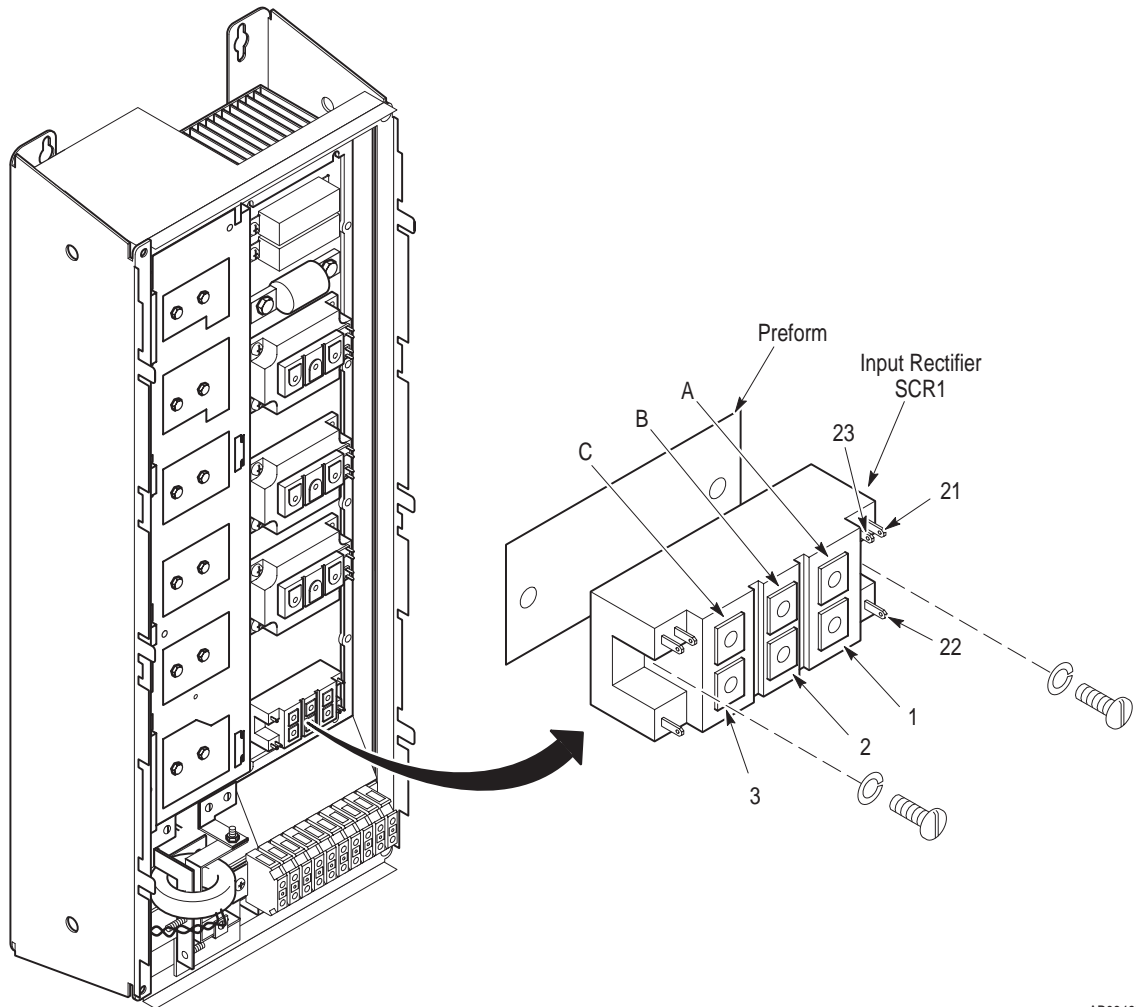

AB0349B

Removal



ATTENTION: Disconnect and lock out power from the drive before disassembling the drive. Failure to disconnect power may result in death or serious injury. Verify bus voltage by measuring the voltage between +DC and -DC on Terminal Block TB1. Do not attempt to service the drive until the bus voltage has discharged to zero volts.



ATTENTION: Wear a wrist-type grounding strap when servicing 1336 FORCE Drives. Failure to protect drive components against ESD may damage drive components. Refer to Electrostatic Discharge Precautions at the beginning of this chapter.

Important: Before you remove connections and wires from the drive components, mark the connections and wires to correspond with their component connections and terminals to prevent incorrect wiring during assembly.

1. Remove power from the drive.
2. Check for zero volts at TB1 terminals +DC and –DC.
3. Check for absence of control voltage at:
 - TB20 and TB21 on drives using a PLC Comm Adapter Board
 - TB5, TB6, and TB7 on drives using a Standard Adapter Board
4. Remove the Snubber Board from the drive. Refer to Chapter 2 – Disassembly and Access Procedures, Removing the Snubber Board.
5. Remove all wires from the Input Rectifier.
6. Remove the screws fastening the Input Rectifier to the heat sink.

Installation

1. Clean all surfaces between the Input Rectifier and the heat sink using a soft, clean cloth.
2. Replace the Preform between the Input Rectifier and the heat sink.
3. Install the Input Rectifier in reverse order of removal. Refer to Table 2.A – Fastener Torque Specifications.



ATTENTION: Replace all guards and insulators before applying power to the drive. Failure to replace guards may result in death or serious injury.

Fan

The Fan is located behind and on the bottom of the heat sink.

Figure 4.7
Fan

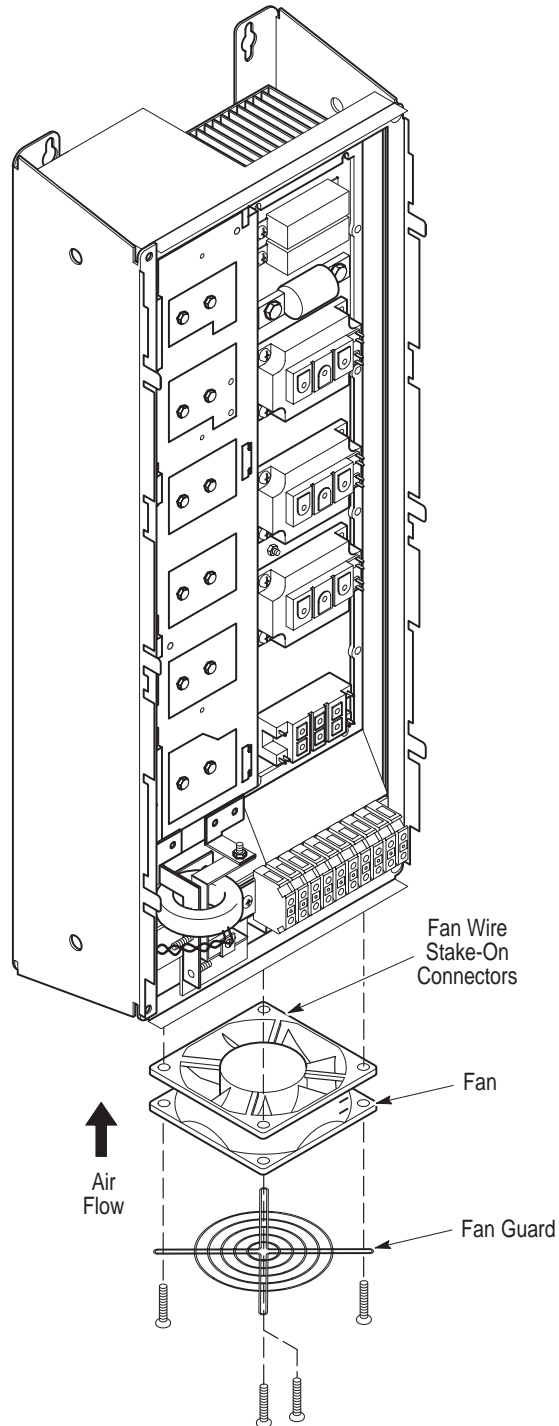

AB0323A

Removal



ATTENTION: Disconnect and lock out power from the drive before disassembling the drive. Failure to disconnect power may result in death or serious injury. Verify bus voltage by measuring the voltage between +DC and –DC on Terminal Block TB1. Do not attempt to service the drive until the bus voltage has discharged to zero volts.



ATTENTION: Wear a wrist-type grounding strap when servicing 1336 FORCE Drives. Failure to protect drive components against ESD may damage drive components. Refer to Electrostatic Discharge Precautions at the beginning of this chapter.

Important: Before you remove connections and wires from the drive components, mark the connections and wires to correspond with their component connections and terminals to prevent incorrect wiring during assembly.

1. Remove power from the drive.
2. Check for zero volts at TB1 terminals +DC and –DC.
3. Check for absence of control voltage at:
 - TB20 and TB21 on drives using a PLC Comm Adapter Board
 - TB5, TB6, and TB7 on drives using a Standard Adapter Board
4. Remove the four screws fastening the Fan assembly to the bottom of the Drive.
5. Remove the wires from the Fan stake-on connectors.

Installation

Install the fan in reverse order of removal. Refer to Table 2.A – Fastener Torque Specifications.

Important: When fastening the Fan to the cover plate, position the air flow arrow, located on the top of the fan near the connectors, so it points to the top of the drive. Position the Fan connectors to the front, away from DC Bus Inductor L1. Connect the red wire to the positive fan terminal and the black wire to the negative terminal.



ATTENTION: Replace all guards and insulators before applying power to the drive. Failure to replace guards may result in death or serious injury.

DC Bus Inductor L1

The DC Bus Inductor L1 is located on the lower left corner of the drive, behind the Ground Sense CT.

Figure 4.8
DC Bus Inductor L1

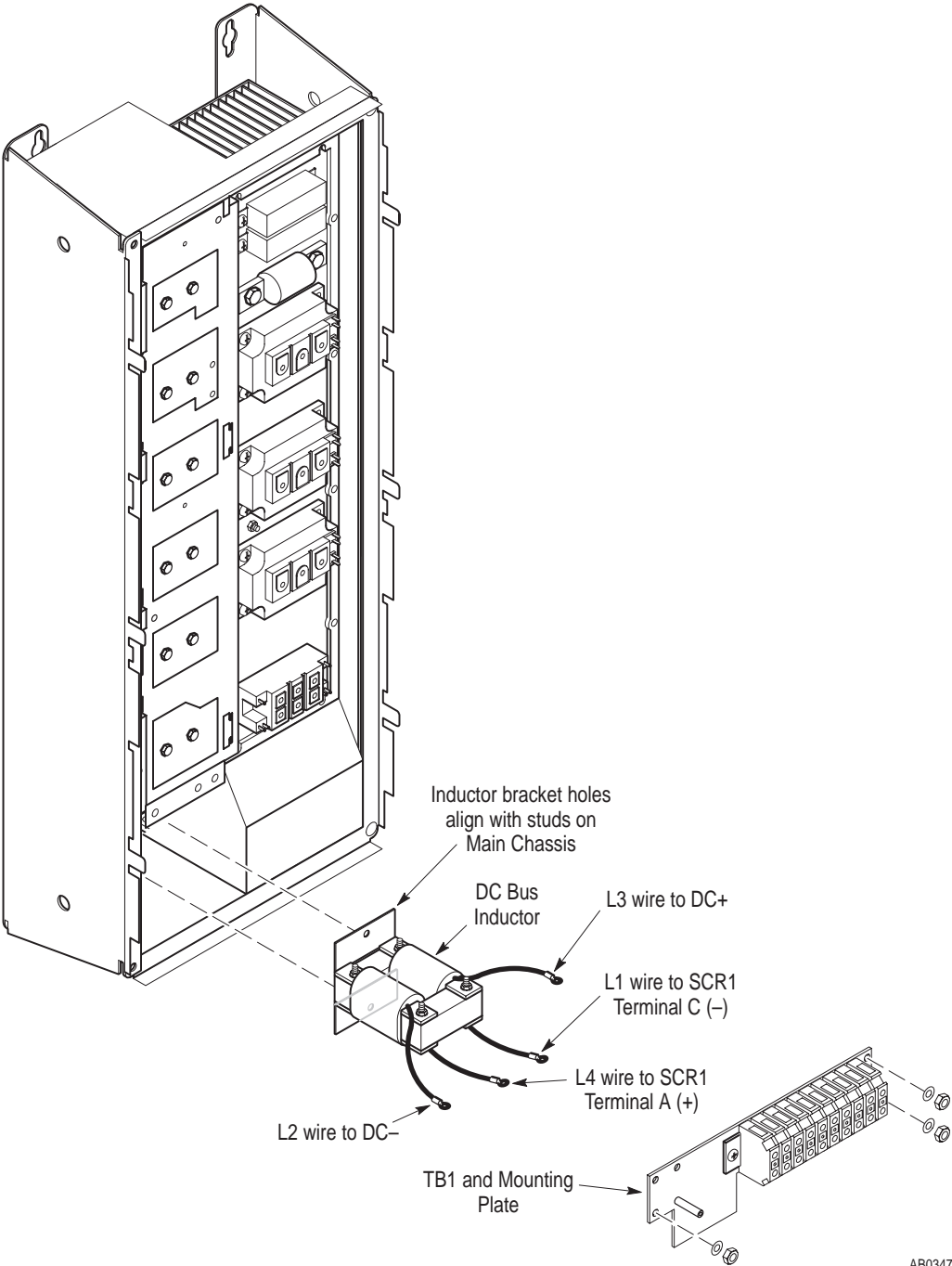

AB0347A

Removal



ATTENTION: Disconnect and lock out power from the drive before disassembling the drive. Failure to disconnect power may result in death or serious injury. Verify bus voltage by measuring the voltage between +DC and –DC on Terminal Block TB1. Do not attempt to service the drive until the bus voltage has discharged to zero volts.



ATTENTION: Wear a wrist-type grounding strap when servicing 1336 FORCE Drives. Failure to protect drive components against ESD may damage drive components. Refer to Electrostatic Discharge Precautions at the beginning of this chapter.

Important: Before you remove connections and wires from the drive components, mark the connections and wires to correspond with their component connections and terminals to prevent incorrect wiring during assembly.

Access the Main Chassis:

1. Remove power from the drive.
2. Check for zero volts at TB1 terminals +DC and –DC.
3. Check for absence of control voltage at:
 - TB20 and TB21 on drives using a PLC Comm Adapter Board
 - TB5, TB6, and TB7 on drives using a Standard Adapter Board
4. Remove the Precharge Board. Refer to Chapter 2 – Disassembly and Access Procedures, Removing the Precharge Board.
5. Remove the Gate Driver Board. Refer to Chapter 2 – Disassembly and Access Procedures, Removing the Gate Driver Board.
6. Remove the Bus Capacitor Bank. Refer to Bus Capacitor Bank in this chapter.

Remove the TB1 Mounting Plate and DC Bus Inductor L1:

1. Remove the following from the drive-connection side of TB1:
 - Ground wires
 - Wires at terminals U, V, and W (T1, T2, and T3)

2. Remove the following from the Ground Sense CT Bus Bars:
 - L3 wire from DC Bus Inductor L1.
 - L2 wire from DC Bus Inductor L1. Note that the positive (+) and negative (-) DC wires from TB1 may remain connected to the bus bars.
3. Remove the following from the Snubber Board:
 - DC Bus Inductor wire L1 from SCR1 terminal C (-).
 - DC Bus Inductor wire L4 from SCR1 terminal A (+).
 - TB1 terminal wire R from SCR1 terminal 3.
 - TB1 terminal wire S from SCR1 terminal 2.
 - TB1 terminal wire T from SCR1 terminal 1.
4. Remove the nuts fastening the TB1 Mounting Plate to the drive to remove the plate from the drive.
5. Pull the Bus Inductor straight out of the drive to remove the inductor from the drive.



ATTENTION: Note the position of the bracket toward the lower end of the inductor. The tab on the bottom right of the inductor bracket fits into a hole on the TB1 mounting plate. Correctly position the replacement inductor brackets to prevent damage to the equipment.



ATTENTION: Holes in the inductor bracket align with pins located on the inside-back of the Main Chassis. Correctly align the holes on the replacement inductor bracket with the chassis pins to prevent damage to the equipment.

Installation

1. Lower the inductor into the Main Chassis, aligning the hole in the bottom inductor bracket with the peg on the chassis.
2. Install DC Bus Inductor L1 in reverse order of removal. Refer to Table 2.A – Fastener Torque Specifications.



ATTENTION: Replace all guards and insulators before applying power to the drive. Failure to replace guards may result in death or serious injury.

Bus Capacitor Bank

The Bus Capacitor Bank is located on the left side of the Main Chassis.

Figure 4.9
Bus Capacitor Bank

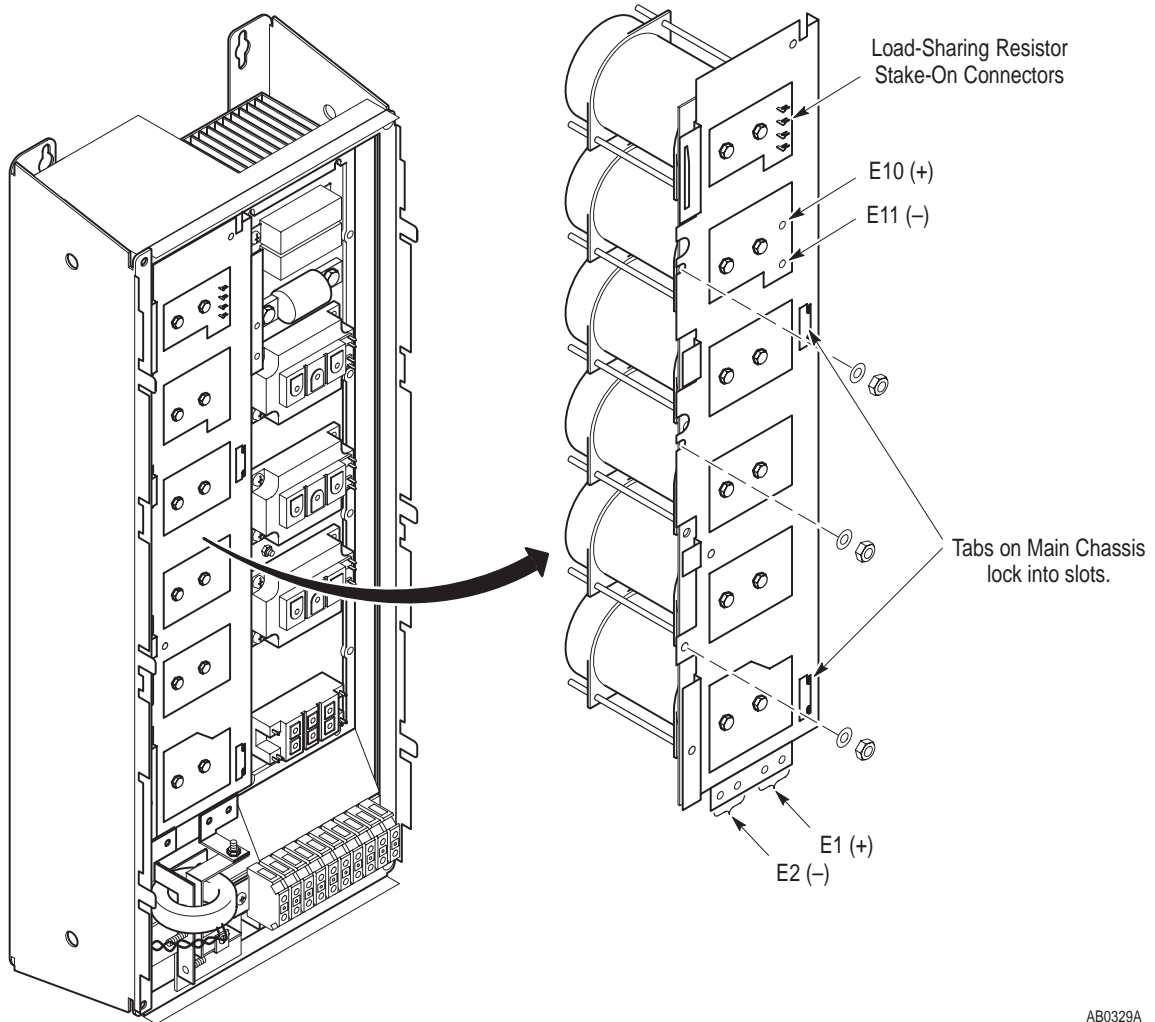

AB0329A

Removal



ATTENTION: Disconnect and lock out power from the drive before disassembling the drive. Failure to disconnect power may result in death or serious injury. Verify bus voltage by measuring the voltage between +DC and -DC on Terminal Block TB1. Do not attempt to service the drive until the bus voltage has discharged to zero volts.



ATTENTION: Wear a wrist-type grounding strap when servicing 1336 FORCE Drives. Failure to protect drive components against ESD may damage drive components. Refer to Electrostatic Discharge Precautions at the beginning of this chapter.

Important: Before you remove connections and wires from the drive components, mark the connections and wires to correspond with their component connections and terminals to prevent incorrect wiring during assembly.

Access the Main Chassis:

1. Remove power from the drive.
2. Check for zero volts at TB1 terminals +DC and –DC.
3. Check for absence of control voltage at:
 - TB20 and TB21 on drives using a PLC Comm Adapter Board
 - TB5, TB6, and TB7 on drives using a Standard Adapter Board
4. Remove the Precharge Board. Refer to Chapter 2 – Disassembly and Access Procedures, Removing the Precharge Board.
5. Remove the Gate Driver Board. Refer to Chapter 2 – Disassembly and Access Procedures, Removing the Gate Driver Board.

Remove the Bus Capacitor Bank:

1. Remove the Load Sharing Resistor wires from the Bus Capacitor Bank stake-on connectors.
2. Remove the four screws fastening the Snubber Board Bus Bars to the Bus Capacitor Bank terminals E10 (+) and E11 (–).
3. Loosen the screws fastening the Snubber Board negative Bus Bar to the Snubber Board.



ATTENTION: These screws are fastened with nuts located under the Snubber Board. Removing the screws requires removing the Snubber Board to fasten the bus bar to the Snubber Board.

4. Remove the four screws fastening the Ground Sense CT Bus Bars to Bus Capacitor Bank terminals E1 (+) and E2 (–).
5. Remove the three nuts and washers fastening the left side of the Bus Capacitor Bank to the Main Chassis.

6. Slide the Bus Capacitor Bank to the right to unlock the right side of the capacitor frame from the tabs located on the Main Chassis.
7. Pull the Bus Capacitor Bank away from the drive to remove the capacitors from the drive.

Installation

1. Fasten the capacitor assembly in reverse order of removal. Refer to Table 2.A – Fastener Torque Specifications.
2. Connect the Load Sharing Resistors to the Bus Capacitors according to the following diagram.

Figure 4.10
Load Sharing Resistor Connections to Bus Capacitors

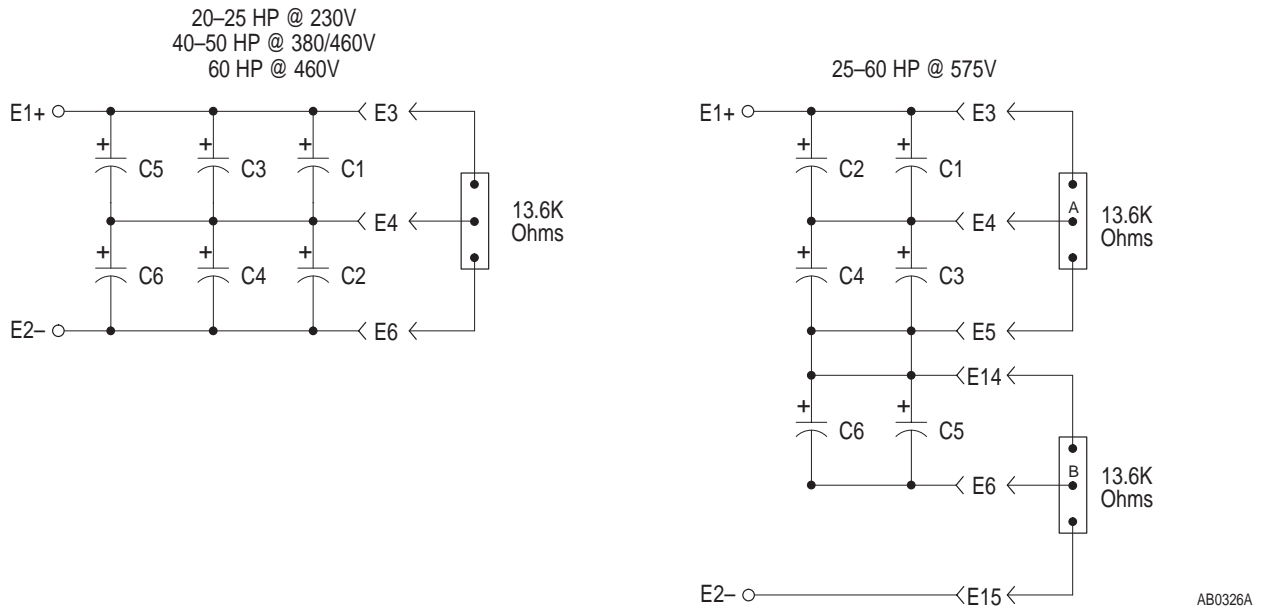

ATTENTION: The Capacitor Bus PCB must connect a positive (+) capacitor terminal to a negative (-) capacitor terminal. Capacitors not connected correctly will explode and cause death or serious injury.

Replacement Parts List

Chapter Objectives

This chapter illustrates and lists replacement parts for the 1336 FORCE Drives rated A020 – A030, B040, B050, BX040, BX060, and C025 – C060 and describes replacement parts ordering procedures.

The following illustration and table show you parts, part names, locations, and chapters for replacement procedures.

Ordering Replacement Parts

For your convenience, the Allen-Bradley Drives Division and the Allen-Bradley Support Division provide efficient and convenient repair and exchange for eligible equipment.

A product service report number is required to return any equipment for repair. Your local Allen-Bradley distributor or area sales and support office can provide you with a product service report number.

You should return equipment to be repaired to the area sales and support center nearest you. Reference the product service report number on the carton and packing slip. Include:

- Your company name
- Your company address
- The repair purchase order number
- A brief description of the problem

Contact your local Allen-Bradley distributor or sales office for a complete listing of area sales and support centers near you.

For parts catalog numbers, refer to the 1336 FORCE Spare Parts Pricing publication included with your drive documentation set.

Replacement Parts Listing

Figure 5.1
Parts for A020 – A030, B040, B050, BX040, BX060, and
C025 – C060 Drives

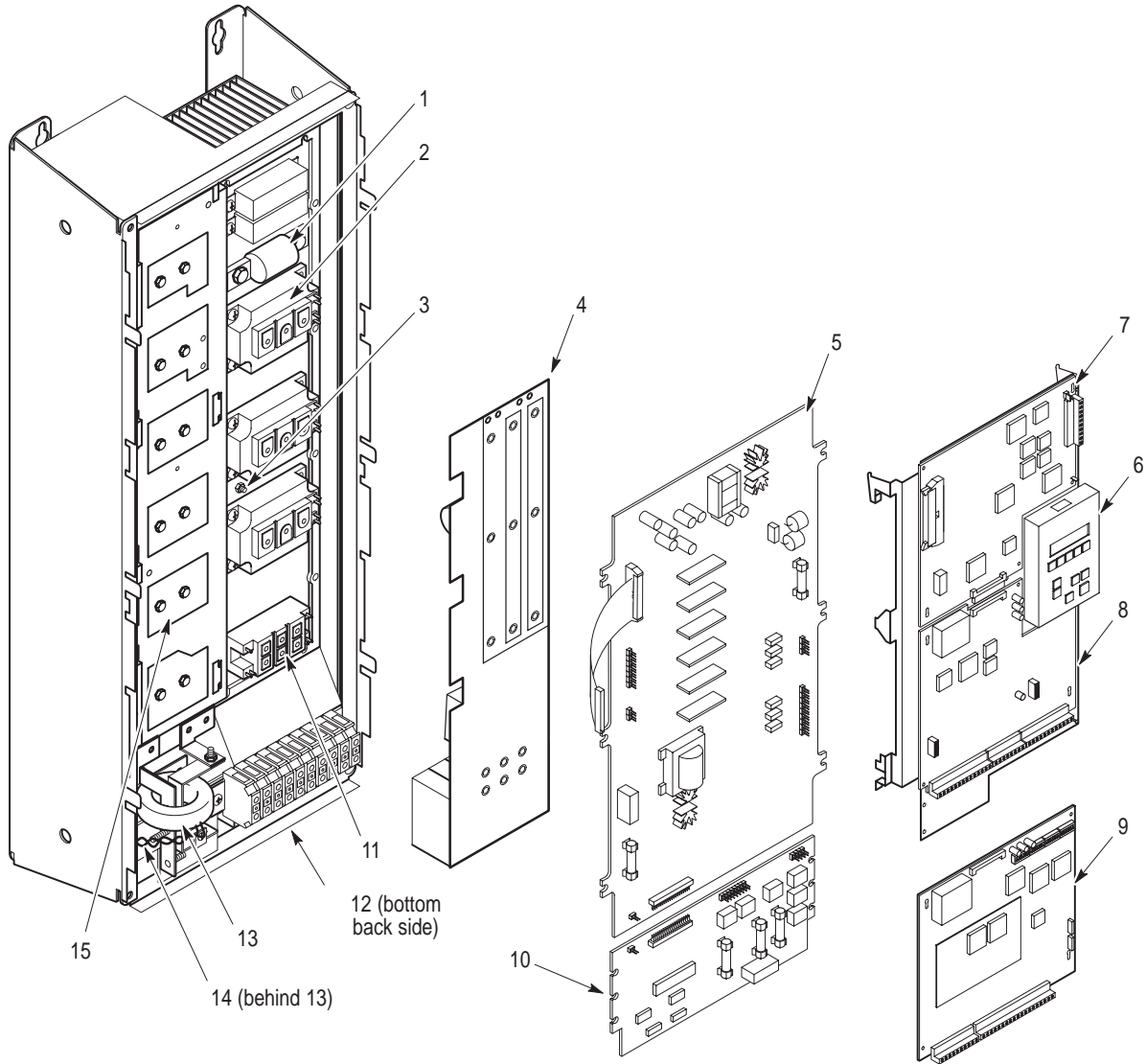

AB0587A

Table 5.A
Replacement Parts for A020 – A030, B040, B050, BX040,
BX060, and C025 – C060 Drives

| Callout | Symbol | Description | Location | Replacement Procedures |
|---------|----------------|------------------------------|--------------------------------------|--|
| 1 | F1 | Bus Fuse | Heat Sink | Chapter 5, Bus Fuse F1 |
| 2 | Q1-3 | Transistor | Heat Sink | Chapter 5, Transistor Modules |
| 3 | ST | Thermistor | Heat Sink | Chapter 5, Thermistor |
| 4 | SNUBBER BOARD | Snubber Board | — | Chapter 3, Removing the Snubber Board |
| 5 | BASEDR/PWRSPLY | Gate Driver/Power Supply PCB | — | Chapter 3, Removing the Gate Driver Board |
| 6 | LOCAL DIS | Human Interface Module | Control Board/Adapter Mounting Plate | Chapter 1, Module Removal |
| 7 | MAIN CTL | Main Control PCB | Main Control Board | Chapter 3, Removing the Main Control Board from the Mounting Plate |
| 8 | GT2 | Standard Adapter Board | Control Board/Adapter Mounting Plate | Chapter 3, Removing the Standard Adapter Board |
| 9 | GT1 | PLC Comm Board | Control Board/Adapter Mounting Plate | Chapter 3, Removing the PLC Comm Board |
| 10 | PRECHARGE | Precharge Board | — | Chapter 3, Removing the Precharge Board |
| 11 | SCR1 | Input Rectifier | Heat Sink | Chapter 5, Input Rectifier SCR1 |
| 12 | FAN | Fan | Main Chassis | Chapter 5, Fan |
| 13 | GND SENSE | Ground Sense CT | — | Chapter 5, Ground Sense CT |
| 14 | L1 | DC Bus Inductor | Main Chassis | Chapter 5, DC Bus Inductor L1 |
| 15 | C1-C6 | Bus Capacitors | Main Chassis | Chapter 5, Bus Capacitors |

This Page Intentionally Left Blank

**Schematics — 20 – 60 HP 1336 FORCE
Drives**

TABLE 1 – FUSES

| | DC FUSE | LINE FUSE |
|-------------------|-----------|-----------|
| | INVERTER | (AC) |
| | F1 | FR,FS,FT |
| HP RATING | A70Q TYPE | TYPE JJ |
| 230VAC | | |
| | | |
| 20 | 100A,700V | 100A |
| 25 | 125A,700V | 100A |
| 30 | 125A,700V | 100A |
| 380/460VAC | | |
| 40CT 50VT | 100A,700V | 90A |
| 50CT 60VT | 125A,700V | 100A |
| 60 460V ONLY | 125A,700V | 100A |
| 575VAC | | |
| | | |
| 25 | 50A,700V | 40A |
| 30 | 60A,700V | 50A |
| 40 | 70A,700V | 60A |
| 50 | 90A,700V | 80A |
| 60 | 100A,700V | 90A |

CAP BANK DETAILS

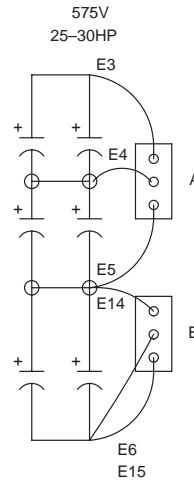
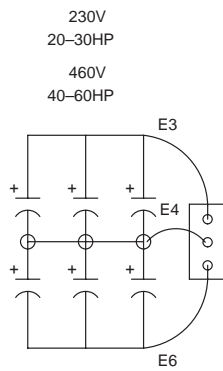

Schematic Diagram
Stand Alone Unit
Bulletin 1336 FORCE
200-240 Volt: 15-22 kW (20-30 HP)
380-480 Volt: 30-44 kW (40-60 HP)
500-600 Volt: 18.5-44 kW (25-60 HP)

AB0757A

This Page Intentionally Left Blank

Glossary

AC Contactor: An alternating-current (AC) contactor is designed for the specific purpose of establishing or interrupting an AC Power circuit.

Adjustable Speed: The concept of varying the speed of a motor, either manually or automatically. The desired operating speed (set speed) is relatively constant regardless of load.

Adjustable Speed Drive (Electrical): The adjustable speed drive is comprised of the motor, drive controller and operator's controls (either manual or automatic).

Ambient Temperature: The temperature of the medium (air, water, earth) into which the heat of the equipment is dissipated.

Base Speed: The manufacturer's nameplate rating where the motor will develop rated power at rated load and voltage. With DC drives, it is commonly the point where full armature voltage is applied with full-rated field excitation. With AC systems, it is commonly the point where 60 Hz is applied to the induction motor.

BR: Refer to *Bridge Rectifier*.

Braking: A method of stopping or reducing the time required to stop an AC motor, and can be accomplished in several ways:

1. DC-Injection braking (AC drives) — A method which produces electromagnetic braking forces in the motor by removing 2 AC motor (stator) phases and injecting DC current. The result is a linear braking characteristic (ramp) that does not diminish with motor speed. Application is normally limited to 10–20% of rated motor speed due to increased heating in the rotor.
2. Dynamic braking (AC drives) — A method which produces electromagnetic braking forces in the motor by dissipating generated power into the DC bus through a resistive load. Braking force remains constant and is only limited by the thermal capacity of the resistors. The result is a linear braking characteristic (ramp) that does not diminish with motor speed.
3. Regenerative braking — A method which produces electromagnetic braking forces in the motor by electronically controlling the return of generated power to the AC supply. The result is a controllable linear braking characteristic (ramp) that does not diminish with motor speed.

4. **Motor-mounted or separately-mounted brake** — A positive-action, mechanical friction device. Normal configuration is such that when the power is removed, the brake is set. This can be used as a holding brake. (Note: A separately mounted brake is not one which is located on some part of the mechanical drive train other than the motor.)

Breakaway Torque: The torque required to start a machine from standstill. Breakaway torque is always greater than the torque needed to maintain motion.

Breakdown Torque: The breakdown torque of an AC motor is the maximum torque which it will develop with rated voltage applied at rated frequency.

Bridge Rectifier: (Diode, SCR) A non-controlled, full-wave rectifier that produces a constant, rectified, DC voltage. An SCR bridge rectifier is a full-wave rectifier with a DC output that can be controlled by switching on the gate control element.

Bridge Rectifier: A full-wave rectifier that conducts current in only one direction of the input current. AC applied to the input results in approximate DC at the output.

British Thermal Unit: (BTU) The quantity of heat required to raise one pound of water by one degree Fahrenheit.

BTU: Refer to *British Thermal Unit*.

Bus: A single path or multiple parallel paths for power or data signals to which several devices may be connected at the same time. A bus may have several sources of supply and/or several sources of demand.

Bus Sense: A signal transducer that generates a signal proportional to the current in the drive's DC bus. The control logic uses this signal to sense the presence or absence of bus voltage.

CEMF: Refer to *Counter Electromotive Force*.

CMOS: Complimentary Metallic Oxide Semiconductor. A semiconductor device in which an electric field controls the conductance of a channel under a metal electrode called a gate.

Cogging: A condition in which a motor does not rotate smoothly but steps or jerks from one position to another during shaft revolution. Cogging is most pronounced at low motor speeds and can cause objectionable vibrations in the driven machinery.

Constant Torque Range: A speed range in which a motor is capable of delivering a constant torque, subject to cooling limitations of the motor.

Constant Voltage Range: (AC Drives) The range of motor operation where the drive's output voltage is held constant as output frequency is varied. This speed range produces motor performance similar to a DC drive's constant horsepower range.

Constant Volts per Hertz (V/Hz): The V/Hz relationship exists in AC drives where the output voltage is directly proportional to frequency. This type of operation produces constant rated torque as the motor's speed varies.

Continuous Duty (CONT): A motor that can continue to operate without stopping and remain within the insulation temperature limits after it has reached normal operating (equilibrium) temperature.

Converter:

1. A device for changing AC to DC. This is accomplished through use of a diode rectifier or thyristor rectifier circuit.
2. A device for changing AC to DC to AC (e.g., adjustable frequency drive). A frequency converter, such as that found in an adjustable frequency drive, consists of a rectifier, a DC intermediate circuit, an inverter, and a control unit.

Counter Electromotive Force (CEMF): The product of a motor armature rotating in a magnetic field. This generating action takes place whenever a motor is rotating. Under stable motoring conditions the generated voltage (CEMF) is equal to the voltage supplied to the motor minus small losses. However, the polarity of the CEMF is opposite to that of the power being supplied to the armature.

Current Limiting: An electronic method of limiting the maximum current available to the motor. This is adjustable so that the motor's maximum current can be controlled. It can also be preset as a protective device to protect both the motor and the control from extended overloads.

DC Boost: Compensates for the voltage drop across the resistance of an AC motor circuit and the resulting reduction in torque.

DC Bus: A drive's power structure that transmits a rectified AC line power from the bridge rectifier to the output transistors.

DC Hold: Describes a "holding brake" function to stop motor rotation after a ramp-to-stop function is activated.

Diode: A solid-state uni-directional conductor.

Drift: A slow change in some characteristic of a device. For a drive, it is the deviation from the initial set speed with no load change over a specific time period. Normally the drive must be operated for a specified warm-up time at a specified ambient temperature before drift specifications apply. Drift is normally caused by random changes in operating characteristics of various control components.

Drive Controller (Variable Speed Drive) (Drive): An electronic device that can control the speed, torque, horsepower, and direction of an AC or DC motor.

1. PWM drive — is a motor drive using pulse-width modulation techniques to control power to the motor. A high-efficiency drive used for high-response applications.
2. SCR drive — is a motor drive that uses SCRs as the power control elements. Usually used for low-bandwidth high-power applications.
3. Servo drive — is a motor drive that uses internal feedback loops for motor current and/or velocity.
4. Vector drive — is an AC static motor drive using power-control techniques that produce motor performance similar to DC static drives.

Duty Cycle:

1. The ratio of working time to total time for an intermittently operating device. Usually expressed as a percentage.
2. The ratio of pulse width to the interval between like portions of successive pulses. Usually expressed as a percentage.

Dynamic Braking: Refer to *Braking*.

Efficiency: Ratio of output to input, indicated by a percentage. In a motor, it is the effectiveness with which the motor converts electrical energy into mechanical energy. In a power supply, it is the effectiveness with which the power supply converts AC power into DC power.

Electrostatic Discharge (ESD): A static-electricity discharge that may damage drive components. Refer to the ESD precautions found in this manual to guard against damage to drive components.

Enable: To activate logic by the removal of a suppression signal.

Enclosure: The housing in which equipment is mounted. They are available in designs for various environmental conditions. Refer to NEMA standard for specifications of different types of enclosures.

ENUM (Enumeration): An ANSI C standard extension to the C language. An ENUM is a set of named integer constants that specify all the legal values a variable of a given type may have. The keyword ENUM signals the start of an enumeration type.

ESD: Refer to *Electrostatic Discharge*.

Floating Ground: An electrical circuit common which is not at earth ground potential or the same ground potential as circuitry with which it interfaces. A voltage difference can exist between the floating ground and earth ground.

Force: The tendency to change the motion of an object with an exertion of energy from a separate source.

Full Load Torque: The full-load torque of a motor is the torque necessary to produce rated horsepower at full-load speed.

Gate:

1. A logic element that blocks or passes a signal, depending on the status of specified input signals.
2. The control element of an SCR.

GND Sense: A current transducer that detects an unequal or imbalanced current in the three-phase AC line or DC bus of the drive. The imbalance indicates an output ground fault condition.

Horsepower (hp): A unit of power: 1 hp = 33,000 ft-lb/min. = 746 watts.

IEC: International Electrotechnical Commission.

IGBT: Refer to *Insulated Gate Bipolar Transistor*.

Induction Motor: An induction motor is an alternating-current motor in which the primary winding on one member is connected to the power source. A secondary winding on the other member carries the induced current. There is no physical electrical connection to the secondary winding; its current is induced.

Inertia: A measure of a body's resistance to change in velocity, whether a body is at rest or moving at a constant velocity. The velocity can be either linear or rotational. The moment of inertia (WK^2) is the product of the weight (W) of an object and the square of the radius of gyration (K^2). The radius of gyration is a measure of how the mass of the object is distributed about the axis of rotation. WK^2 is usually expressed in units of lb-ft².

Insulated Gate Bipolar Transistor (IGBT): A type of transistor commonly used in drive-control devices.

Integral-Horsepower Motor: A motor that has a continuous rating of 1 hp or more, built into a frame.

International Organization for Standards (ISO): An organization established to promote development of international standards.

Interposing Relay: An interposing relay is a relay that accepts control signals of one logic level in order to provide isolated contact signals in a circuit operating at a different logic level.

Inverter:

1. An AC adjustable frequency drive.
2. A particular section of an AC drive. This section uses the DC voltage from a previous circuit stage (intermediate DC circuit) to produce a pulse-width-modulated or stepped AC current or voltage waveform that has characteristics similar to the desired sine-wave frequency.
3. A circuit whose output signal is the inverse of its input (a positive-going pulse is inverted to a negative-going pulse, and vice versa).

ISO: Refer to *International Organization for Standards*.

Isolation Transformer:

1. A transformer that provides DC isolation from other equipment not connected to that transformer secondary.
2. A transformer that provides noise isolation between the primary and secondary by such means as a Faraday shield.

Jogging:

1. In a numerical control system, an operator manually generating motion (continuously or incrementally) by closing a switch.
2. An operator generating motion by closing a switch.

Kinetic Energy: The energy of motion of a moving body.

LAD: Refer to *Linear Acceleration/Deceleration*.

LEM: A hall-effect current transducer that senses drive output current and generates a signal for the control logic.

Linear Acceleration/Deceleration (LAD): A circuit that controls the rate at which a motor is allowed to accelerate to a set speed or decelerate to zero speed. On most drives, this circuit is adjustable and can be set to accommodate a particular application.

Linearity: A measure of how closely a characteristic follows a straight-line function.

Locked-Rotor Current: Steady-state current taken from the line current with the a rotor at standstill (at rated voltage and frequency). This is the current when starting the motor and load.

Locked-Rotor Torque: The minimum torque that a motor will develop at rest for all angular positions of the rotor (with rated voltage applied at rated frequency).

Megger Test: A test used to measure an insulation system's resistance. This is usually measured in megohms by applying a high voltage.

MOV: Refer to *Surge Protection*.

National Electrical Code (NEC): A set of regulations governing the construction and installation of electrical wiring and apparatus, established by the National Fire Protection Association and suitable for mandatory application by governing bodies exercising legal jurisdiction. It is widely used by state and local authorities within the United States.

National Electrical Manufacturer's Association (NEMA): A non-profit organization organized and supported by electrical equipment and supply manufacturers. Some NEMA motor standards include horsepower (hp) ratings, speeds, frame sizes and dimensions, torques, and drive enclosures.

NEC: Refer to *National Electrical Code*.

Negative Slope: The location on a V/Hz curve where the break voltage exceeds the base voltage.

NEMA: Refer to *National Electrical Manufacturer's Association*.

Offset: The steady-state deviation of a controlled variable from a fixed setpoint.

Op Amp: An operational amplifier. A high-gain stable linear DC amplifier that is designed to be used with external circuit elements.

Open Loop System: A control system that has no means of comparing the output with the input for control purposes.

Overload Capacity: The ability of the drive to withstand currents beyond the system's continuous rating. It is normally specified as a percentage of full-load current endured for a specified time period. Overload capacity is defined by NEMA as 150% of rated full load current for one minute for "standard industrial DC motors."

PC:

1. Personal Computer.
2. Programmable Controller.
3. Printed Circuit.

Plugging: A type of motor braking provided by reversing either line voltage polarity or phase sequence so that the motor develops a counter torque that exerts a retarding force to brake the motor.

Pot: A potentiometer, or variable resistor.

Power: Work done per unit of time. Measured in horsepower (hp) or watts (W): 1 hp = 33,000 ft-lb/min. = 746 W.

Power Factor (Displacement): A measurement of the time phase difference between the fundamental voltage and fundamental current in an AC circuit. It represents the cosine of the phase angle difference.

$$F_p = \cos(\alpha - \beta)$$

Power Factor (Distortion): A measurement of the ratio of the real power (kW) to the apparent power (kVA). Distortion power factor takes into account harmonic voltage and current distortion as well as voltage-to-current displacement.

Preform: A flexible material used between an electronic component and the heat sink to which the component is attached. Preform provides maximum heat dissipation from the component to the heat sink.

Preset Speed: Describes one or more fixed speeds at which a drive operates.

Programmable Controller: A solid-state control system that has a user-programmable memory for storage of instructions to implement specific functions such as I/O control, logic, timing, counting, report generation, communication, arithmetic, and data file manipulation. A controller consists of a central processor, input/output interface, and memory. A controller is designed as an industrial control system.

Pull-In Torque: The maximum constant torque to which a synchronous motor accelerates into synchronism at rated voltage and frequency.

Pull-Out Torque: The maximum running torque of a synchronous motor.

Pull-Up Torque: The torque required to accelerate the load from standstill to full speed (where breakdown torque occurs), expressed in percent of running torque. It is the torque required not only to overcome friction, windage, and product loading but also to overcome the inertia of the machine. The torque required by a machine may not be constant after the machine has started to turn. This load type is characteristic of fans, centrifugal pumps, and certain machine tools.

PWM: Pulse-width Modulation. A technique used to eliminate or reduce unwanted harmonic frequencies when inverting DC voltage to sine wave AC.

Reactance: Pure inductance or capacitance, expressed in ohms, in a circuit. It is the component of impedance to alternating current that is not resistance.

Rectifier: A device that conducts current in only one direction, thereby transforming alternating current to direct current.

Regeneration: (AC drives) When the rotor synchronous frequency is greater than the applied frequency.

Regenerative Braking: Slows or stops a motor through regeneration. Refer to *Regeneration* and *Braking*.

Resolution: The smallest distinguishable increment into which a quantity can be divided (e.g., position or shaft speed). It is also the degree to which nearly equal values of a quantity can be discriminated. For rotary encoders, it is the number of unique electrically identified positions occurring in 360 degrees of input shaft rotation. For D/A or A/D conversion, may be expressed as the number of bits in the digital value that corresponds to a full-scale analog value.

SCR: Silicon Controlled Rectifier. A solid-state uni-directional latching switch.

Service Factor: When used on a motor nameplate, a number that indicates how much above the nameplate rating a motor can be loaded without causing serious degradation (i.e., a motor with 1.15 S-F can produce 15% greater torque than one with 1.0 S-F).

Set Speed: The desired operating speed.

Shock Load: The load seen by a clutch, brake, or motor in a system that transmits high peak loads. This type of load is present in crushers, separators, grinders, conveyors, winches, and cranes.

Slip: The difference between rotating magnetic field speed (synchronous speed) and rotor speed of AC induction motors. Usually expressed as a percentage of synchronous speed.

Slip Compensation: Monitors motor current and compensates for speed lost due to increased motor slip. The amount of slip is proportional to the motor load.

Speed Range: The speed minimum and maximum at which a motor must operate under constant or variable torque load conditions. A 50:1 speed range for a motor with top speed 1800 rpm means the motor must operate as low as 36 rpm and still remain within regulation specification. Controllers are capable of wider controllable speed ranges than motors because there is no thermal limitation, only electrical. Controllable speed range of a motor is limited by the ability to deliver 100% torque below base speed without additional cooling.

Speed Regulation: The numerical measure (percent) of how accurately the motor speed can be maintained. It is the percentage of change in speed between full load and no load. The ability of a drive to operate a motor at constant speed (under varying load), without “hunting” (alternately speeding up and slowing down). It is related to both the characteristics of the load being driven and electrical time constants in the drive regulator circuits.

Surge Protection: The process of absorbing and clipping voltage transients on an incoming AC power line or control circuit. Surge protectors include MOVs (Metal Oxide Varistors) and specially designed R-C networks.

Synchronous Speed: The speed of an AC induction motor’s rotating magnetic field. It is determined by the frequency applied to the stator and the number of magnetic poles present in each phase of the stator windings. Mathematically, it is expressed as: Sync Speed (rpm) = 120 x Applied Freq. (Hz) / Number of poles per phase.

Torque: A turning force applied to a shaft, tending to cause rotation. Torque is equal to the force applied, times the radius through which it acts. Torque is measured in pound-feet, ounce-inches, Newton-meters, or gram-centimeters.

Transducer: A device that converts one energy form to another (e.g., mechanical to electrical). When a transducer is actuated by signals from one system or medium, it can supply a related signal to the other system or medium.

Transient: A momentary power deviation in an electrical or mechanical system.

Transistor: An active solid-state semiconductor device.

Work: A force moving an object over a distance.
(work = force x distance)

This Page Intentionally Left Blank

A

Adapter Locations, 1–12
Adapters and Communication Ports, Human Interface Module, 1–11
Audience for this Manual, P–1
Auxiliary Input, Definition, P–7
Auxiliary Interlock, Definition, P–7

B

Bit, Definition, P–7
Bus Capacitor Bank
 Illustration, 4–20
 Installation, 4–22
 Removal, 4–20
 Test, 3–5
Bus Fuse F1
 Illustration, 4–6
 Installation, 4–7
 Removal, 4–7

C

Check, Definition, P–8
Component Test Procedures, 3–1
Connector, Definition, P–8
Control Board Mounting Plate, Illustration, 2–15
Control Interface Board
 Definition, P–9
 Illustration, 2–7
 Installation, 2–8
 Jumper Locations, 1–3
 Removal, 2–8
Control Interface Option, 1–2
Control Logic Wiring, 1–1
Conventions in this Manual, P–7

D

DC Bus Inductor
 Illustration, 4–17
 Installation, 4–19
 Removal, 4–18
Default, Definition, P–8

Drive

 Enclosure Type, P–7
 Identification, P–4
 Illustration, 4–3
 Nameplate Location, P–3
 Rating, P–6
Drive Enclosure
 Illustration, 2–5
 Installation, 2–6
 Removal, 2–6

E

Electrostatic Discharge, P–2
Enable Input, Definition, P–8
Enclosure Type, P–7
ESD, P–2

F

False, Definition, P–8
Fan
 Illustration, 4–14
 Installation, 4–16
 Removal, 4–15
Four-Point Mounting, 2–3

G

Gate Driver Board
 Illustration, 2–19
 Installation, 2–20
 Removal, 2–19
Ground Sense CT
 Illustration, 4–4
 Installation, 4–6
 Removal, 4–4

H

HIM, Removal, 1–13
Human Interface Module (HIM)
 Adapter Locations, 1–12
 Illustration, 1–11
 Operation, 1–14

I

- Input Mode
 - Programming, 1–4
 - Selection, 1–5
 - Three-Wire, Multi-Source, 1–6
 - Two-Wire, Single-Source, 1–6
- Input Rectifier
 - Illustration, 4–12
 - Installation, 4–13
 - Removal, 4–12
 - Test, 3–3
- Inputs, Available, 1–4

J

- Jumper, Definition, P–8

L

- Load Sharing Resistor Connections, 4–22
- Local Programming, 1–5

M

- Main Control Board Mounting Plate
 - Installation, 2–16
 - Removal, 2–15
- Major Component Replacement. *See* Procedures
- Manual
 - Audience, P–1
 - Conventions, P–7
 - Objective, P–1
 - Related Publications, P–9
- Mounting
 - Four-Point, 2–3
 - Two-Point, 2–2

N

- Nameplate Location, P–3

O

- Objective of this Manual, P–1
- Operation, Human Interface Module, 1–14
- Option
 - Control Interface, 1–2
 - Identification, P–4

P

- Parameter, Definition, P–9
- Power Module
 - Illustration, 4–10
 - Installation, 4–11
 - Removal, 4–10
 - Test, 3–8
- Precautions
 - Electrostatic Discharge, P–2
 - Safety, P–1
- Precharge Board
 - Illustration, 2–17
 - Installation, 2–18
 - Removal, 2–17
- Press, Definition, P–9
- Procedures
 - Bus Capacitor Bank Installation, 4–22
 - Bus Capacitor Bank Removal, 4–20
 - Bus Capacitor Bank Test, 3–5
 - Bus Fuse F1, 4–7
 - Component Test, 3–1
 - Control Board Mounting Plate
 - Installation, 2–16
 - Control Board Mounting Plate Removal, 2–15
 - Control Interface Board Installation, 2–8
 - Control Interface L-Option Board
 - Removal, 2–7
 - DC Bus Inductor Installation, 4–19
 - DC Bus Inductor Removal, 4–18
 - Drive Enclosure Installation, 2–6
 - Drive Enclosure Removal, 2–6
 - Fan Installation, 4–16
 - Fan Removal, 4–15
 - Gate Driver Board Installation, 2–20
 - Gate Driver Board Removal, 2–19
 - Ground Sense CT, 4–4, 4–6
 - Input Rectifier Installation, 4–13
 - Input Rectifier Removal, 4–12
 - Input Rectifier Test, 3–3
 - Major Component Replacement, 4–2
 - Power Module Installation, 4–11
 - Power Module Removal, 4–10
 - Power Module Test, 3–8
 - Precharge Board Installation, 2–18
 - Precharge Board Removal, 2–17
 - Replacement Part, 4–1
 - Snubber Board Installation, 2–23
 - Snubber Board Removal, 2–21
 - Thermistor Installation, 4–9
 - Thermistor Removal, 4–8

Programming
 Input Mode, 1-4
 Local, 1-5

R

Rating, Drive, P-6
Related Publications, P-9
Removal, HIM, 1-13
Replacement Part Procedures, 4-1
Replacement Parts, 5-1

S

Safety Precautions, P-1
Schematics, 6-1
Snubber Board
 Illustration, 2-21
 Installation, 2-23
 Removal, 2-22
Speed Select, Input State, 1-8

T

TB3 Terminal Designations, 1-5
Terminal Block Locations, 1-2
Terminal Designations, TB3, 1-5
Thermistor
 Illustration, 4-8
 Installation, 4-9
 Removal, 4-8
Tools, Required for Service, 2-2, 3-2, 4-2
Torque
 Four-Point Mounting Sequence, 2-3
 Maximum for TB Terminals, 1-5
 Specifications, 2-4
 Two-Point Mounting Sequence, 2-2
Troubleshooting, Component Test
 Procedures, 3-1
True, Definition, P-9
Two-Point Mounting, 2-2

W

Wire Sizes, 1-5

This Page Intentionally Left Blank

FOLD HERE

FOLD HERE



BUSINESS REPLY MAIL

FIRST CLASS PERMIT NO. 413 MEQUON, WI

POSTAGE WILL BE PAID BY ADDRESSEE

ALLEN-BRADLEY
Attn: Marketing Communications
P.O. Box 760
Mequon, WI 53092-9907

NO POSTAGE
NECESSARY
IF MAILED
IN THE
UNITED STATES

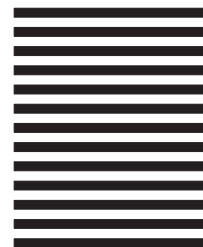

SCANport is a trademark of Allen-Bradley Company, Inc.
PLC is a registered trademark of Allen-Bradley Company, Inc.



Allen-Bradley, a Rockwell Automation Business, has been helping its customers improve productivity and quality for more than 90 years. We design, manufacture and support a broad range of automation products worldwide. They include logic processors, power and motion control devices, operator interfaces, sensors and a variety of software. Rockwell is one of the world's leading technology companies.

Worldwide representation.



Argentina • Australia • Austria • Bahrain • Belgium • Brazil • Bulgaria • Canada • Chile • China, PRC • Colombia • Costa Rica • Croatia • Cyprus • Czech Republic • Denmark • Ecuador • Egypt • El Salvador • Finland • France • Germany • Greece • Guatemala • Honduras • Hong Kong • Hungary • Iceland • India • Indonesia • Ireland • Israel • Italy • Jamaica • Japan • Jordan • Korea • Kuwait • Lebanon • Malaysia • Mexico • Netherlands • New Zealand • Norway • Pakistan • Peru • Philippines • Poland • Portugal • Puerto Rico • Qatar • Romania • Russia-CIS • Saudi Arabia • Singapore • Slovakia • Slovenia • South Africa, Republic • Spain • Sweden • Switzerland • Taiwan • Thailand • Turkey • United Arab Emirates • United Kingdom • United States • Uruguay • Venezuela • Yugoslavia

Allen-Bradley Headquarters, 1201 South Second Street, Milwaukee, WI 53204 USA, Tel: (1) 414 382-2000 Fax: (1) 414 382-4444