

AC Tech

a member of the **Lenze Group**

Drive for Global Excellence

QC Series

Installation and Operation Manual

TABLE OF CONTENTS

1.0	GENERAL	1
	PRODUCTS COVERED IN THIS MANUAL.....	1
	PRODUCT CHANGES.....	1
	WARRANTY.....	1
	RECEIVING.....	1
	CUSTOMER MODIFICATION.....	1
2.0	QC SERIES SPECIFICATIONS	2
3.0	QC SERIES MODEL DESIGNATION CODE	3
4.0	QC SERIES DIMENSIONS	4
5.0	QC SERIES RATINGS	12
6.0	THEORY	15
	DESCRIPTION OF AC MOTOR OPERATION.....	15
	DRIVE FUNCTION DESCRIPTION.....	17
7.0	INSTALLATION	20
8.0	INPUT AC POWER REQUIREMENTS	22
9.0	VOLTAGE SELECTION	23
10.0	POWER WIRING	24
11.0	QC SERIES POWER WIRING DIAGRAM	25
12.0	INITIAL POWER UP	26
13.0	KEYPAD CONTROL	28
	SETTING THE DRIVE FOR KEYPAD CONTROL.....	28
	KEYPAD FUNCTIONS IN LOCAL MODE.....	28
	QC SERIES DISPLAY (NORMAL).....	29
	QC SERIES DISPLAY (ACTUAL SPEED).....	31
	MONITOR MODE.....	31
	QC SERIES FAULT DISPLAY.....	32
14.0	CONTROL WIRING	33
	GENERAL.....	33
	REMOTE CONTROL.....	33
15.0	QC SERIES CONTROL WIRING DIAGRAMS	38
	QC SERIES TERMINAL STRIP.....	38
	TWO-WIRE START/STOP CONTROL.....	39
	ALTERNATE START/STOP CONTROL.....	40
	THREE-WIRE START/STOP CONTROL.....	41
	SPEED POT AND PRESET SPEED CONTROL.....	42
16.0	PROGRAMMING THE QC SERIES DRIVE	43
17.0	PARAMETER MENU	45
18.0	DESCRIPTION OF PARAMETERS	48
19.0	OPTIONS	64
20.0	TROUBLESHOOTING	66
21.0	USER SETTING RECORD	68

1.0 GENERAL

1.1 PRODUCTS COVERED IN THIS MANUAL

This manual covers the AC Tech QC1000, QC2000, and QC3000 Variable Frequency Drives.

1.2 PRODUCT CHANGES

AC Technology Corporation reserves the right to discontinue or make modifications to the design of its products and manuals without prior notice, and holds no obligation to make modifications to products sold previously. AC Technology Corporation also holds no liability for losses of any kind which may result from this action. Instruction manuals with the most up-to-date information are available for download from the AC Tech website (www.actechdrives.com).

1.3 WARRANTY

AC Technology Corporation warrants the QC Series AC motor control to be free of defects in material and workmanship for a period of eighteen months from the date of sale to the user, or two years from the date of shipment, whichever ever occurs first. Any control component, which under normal use, becomes defective, within the stated warranty time period, shall be returned to AC Technology Corporation, freight prepaid, for examination. AC Technology Corporation reserves the right to make the final determination as to the validity of a warranty claim, and sole obligation is to repair or replace only components which have been rendered defective due to faulty material or workmanship. No warranty claim will be accepted for components which have been damaged due to mishandling, improper installation, unauthorized repair and/or alteration of the product, operation in excess of design specifications or other misuse, or improper maintenance. AC Technology Corporation makes no warranty that its products are compatible with any other equipment, or to any specific application, to which they may be applied and shall not be held liable for any other consequential damage or injury arising from the use of its products.

This warranty is in lieu of all other warranties, expressed or implied. No other person, firm or corporation is authorized to assume, for AC Technology Corporation, any other liability in connection with the demonstration or sale of its products.

1.4 RECEIVING

Inspect all cartons for damage which may have occurred during shipping. Carefully unpack equipment and inspect thoroughly for damage or shortage. Report any damage to carrier and/or shortages to supplier. All major components and connections should be examined for damage and tightness, with special attention given to PC boards, plugs, knobs and switches.

1.5 CUSTOMER MODIFICATION

AC Technology Corporation, its sales representatives and distributors, welcome the opportunity to assist our customers in applying our products. Many customizing options are available to aid in this function. AC Technology Corporation cannot assume responsibility for any modifications not authorized by its engineering department.

2.0 QC SERIES SPECIFICATIONS

Storage Temperature	-20° to 70° C
Ambient Operating Temperature (with 8 kHz or lower carrier, derate for higher carriers)	Chassis: -10 to 50° C (40° C for QC3000) Type 1 Enclosed -10 to 50° C (40° C for QC3000) Type 4 / 12 Enclosed -10 to 40° C Type 12 Enclosed -10 to 40° C Type 4X Enclosed -10 to 40° C
Ambient Humidity	Less than 95% (non-condensing)
Altitude	3300 feet (1000 meters) above sea level without derating
Input Line Voltages	200/240 Vac, 400/480 Vac, and 480/590 Vac
Input Voltage Tolerance	+10%, -15%
Input Frequency Tolerance	48 to 62 Hz
Output Wave Form	Sine Coded PWM
Output Frequency	0-120 Hz Standard, 0 - 650 Hz Optional
Carrier Frequency	1.5, 8, 10, or 12 kHz
Frequency Stability	± 0.00006% / °C
Efficiency	97% or better
Power Factor (displacement)	0.96 or better
Service Factor	1.00
Overload Current Capacity (based on drive output current rating)	150 % for one minute (QC1000/2000) 120 % for one minute (QC3000)
Speed Reference Follower	0-10 VDC, or 4-20 mA
Control Voltage	24 VDC
Analog Outputs	0-10 VDC, 2-10 VDC, 4-20 mA Proportional to speed or load 12 VDC Pulse Train (40-50% Duty Cycle) Proportional to speed
Digital Outputs	Form C relays: 2A at 24 VDC or 120 Vac Open-collector output: 40 mA at 30 VDC

3.0 QC SERIES MODEL DESIGNATION CODE

The model number of a QC Series drive gives a full description of the basic drive unit (see example below).

EXAMPLE: Q14005HB

(QC1000, 480 Vac, 5 HP, Type 1 Enclosure with extended enclosure)

	Q1	4	005	H	B	-XXX																								
<p>Series: Q1 = QC1000 Series - Constant Torque - NEMA 1 and Chassis Q2 = QC2000 Series - Constant Torque - NEMA 4 / 12 & 4X Q3 = QC3000 Series - Variable Torque - NEMA 1 and Chassis</p>																														
<p>Input Voltage: 2 = 240/200Vac (For 208 and 240 Vac; 50 or 60 Hz) 4 = 480/400Vac (For 380, 415, 440, 460 and 480 Vac; 50 or 60 Hz) 5 = 590/480Vac (For 440, 460, 480, 575 and 600 Vac; 50 or 60 Hz)</p>																														
<p>Horsepower:</p> <table style="width: 100%; border: none;"> <tr> <td>001 = 1 Hp</td> <td>015 = 15 Hp</td> <td>060 = 60 Hp</td> <td>250 = 250 Hp</td> </tr> <tr> <td>002 = 2 Hp</td> <td>020 = 20 Hp</td> <td>075 = 75Hp</td> <td></td> </tr> <tr> <td>003 = 3 Hp</td> <td>025 = 25 Hp</td> <td>100 = 100Hp</td> <td></td> </tr> <tr> <td>005 = 5 Hp</td> <td>030 = 30 Hp</td> <td>125 = 125Hp</td> <td></td> </tr> <tr> <td>008 = 7½ Hp</td> <td>040 = 40 Hp</td> <td>150 = 150 Hp</td> <td></td> </tr> <tr> <td>010 = 10 Hp</td> <td>050 = 50 Hp</td> <td>200 = 200 Hp</td> <td></td> </tr> </table>							001 = 1 Hp	015 = 15 Hp	060 = 60 Hp	250 = 250 Hp	002 = 2 Hp	020 = 20 Hp	075 = 75Hp		003 = 3 Hp	025 = 25 Hp	100 = 100Hp		005 = 5 Hp	030 = 30 Hp	125 = 125Hp		008 = 7½ Hp	040 = 40 Hp	150 = 150 Hp		010 = 10 Hp	050 = 50 Hp	200 = 200 Hp	
001 = 1 Hp	015 = 15 Hp	060 = 60 Hp	250 = 250 Hp																											
002 = 2 Hp	020 = 20 Hp	075 = 75Hp																												
003 = 3 Hp	025 = 25 Hp	100 = 100Hp																												
005 = 5 Hp	030 = 30 Hp	125 = 125Hp																												
008 = 7½ Hp	040 = 40 Hp	150 = 150 Hp																												
010 = 10 Hp	050 = 50 Hp	200 = 200 Hp																												
<p>Extended Enclosures: H = Extended enclosure. <i>No character indicates standard height enclosure.</i> <i>Required for line reactor option. Line reactors are standard on 240 Vac models from 25 to 60 Hp, 480 Vac models from 25 to 250 Hp, and 590 Vac from 5 to 200 Hp.</i></p>																														
<p>Enclosure Type: A = Chassis - Open Frame B = NEMA 1 - General Purpose, vented: Indoor C = NEMA 4 - Washdown: Indoor / Outdoor (NEMA 4 rating exceeds NEMA 12 rating) D = NEMA 12 - Dust-tight and Drip-tight: Indoor E = NEMA 4X - Washdown, Stainless steel: Indoor / Outdoor</p>																														
<p>Special Designation: Non-standard special models have a three digit suffix.</p>																														

4.0 QC SERIES DIMENSIONS

4.1 QC1000- CHASSIS AND TYPE 1 ENCLOSED

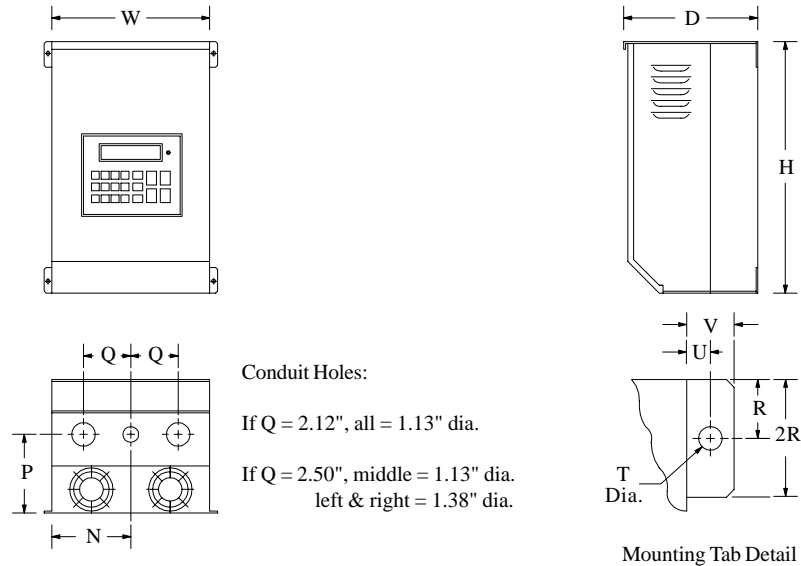

HP	INPUT VOLTAGE	MODEL	H	W	D	N	P	Q	R	T	U	V
1	240 / 200	Q12001	12.00	7.44	5.91	3.72	2.75	2.12	1.00	0.28	0.37	0.68
	480 / 400	Q14001	12.00	7.44	5.91	3.72	2.75	2.12	1.00	0.28	0.37	0.68
	590 / 480	Q15001	12.00	7.44	5.91	3.72	2.75	2.12	1.00	0.28	0.37	0.68
2	240 / 200	Q12002	12.00	7.44	7.91	3.72	4.75	2.12	1.00	0.28	0.37	0.68
	480 / 400	Q14002	12.00	7.44	7.91	3.72	4.75	2.12	1.00	0.28	0.37	0.68
	590 / 480	Q15002	12.00	7.44	7.91	3.72	4.75	2.12	1.00	0.28	0.37	0.68
3	240 / 200	Q12003	12.00	7.44	7.91	3.72	4.75	2.12	1.00	0.28	0.37	0.68
	480 / 400	Q14003	12.00	7.44	7.91	3.72	4.75	2.12	1.00	0.28	0.37	0.68
	590 / 480	Q15003	12.00	7.44	7.91	3.72	4.75	2.12	1.00	0.28	0.37	0.68
5	480 / 400	Q14005	12.00	7.44	7.91	3.72	4.75	2.12	1.00	0.28	0.37	0.68
	590 / 480	Q15005	15.50	7.44	7.91	3.72	4.75	2.12	1.00	0.28	0.37	0.68
7.5	240 / 200	Q12008	14.00	8.88	9.50	4.44	5.75	2.50	1.00	0.28	0.37	0.68
	480 / 400	Q14008	12.00	7.44	7.91	3.72	4.75	2.12	1.00	0.28	0.37	0.68
	590 / 480	Q15008	15.50	7.44	7.91	3.72	4.75	2.12	1.00	0.28	0.37	0.68
10	240 / 200	Q12010	14.00	8.88	9.50	4.44	5.75	2.50	1.00	0.28	0.37	0.68
	480 / 400	Q14010	14.00	8.88	9.50	4.44	5.75	2.50	1.00	0.28	0.37	0.68
	590 / 480	Q15010	19.00	8.88	9.84	4.44	6.13	2.50	1.00	0.28	0.37	0.68
15	240 / 200	Q12015	14.00	8.88	9.50	4.44	5.75	2.50	1.00	0.28	0.37	0.68
	480 / 400	Q14015	14.00	8.88	9.50	4.44	5.75	2.50	1.00	0.28	0.37	0.68
	590 / 480	Q15015	19.00	8.88	9.84	4.44	6.13	2.50	1.00	0.28	0.37	0.68
20	240 / 200	Q12020	19.00	8.88	9.84	4.44	6.13	2.50	1.00	0.28	0.37	0.68
	480 / 400	Q14020	19.00	8.88	9.84	4.44	6.13	2.50	1.00	0.28	0.37	0.68
	590 / 480	Q15020	25.00	8.88	10.50	4.44	6.50	2.50	1.50	0.36	0.37	0.68

4.1 QC1000 - CHASSIS AND TYPE 1 ENCLOSED

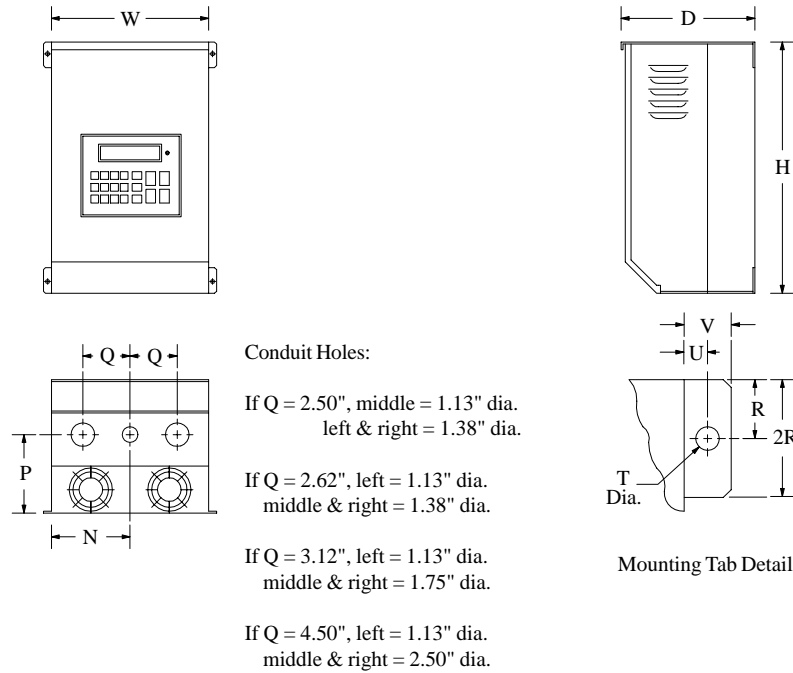

HP	INPUT		H	W	D	N	P	Q	R	T	U	V
	VOLTAGE	MODEL										
25	240/200	Q12025	25.00	8.88	10.50	4.44	6.50	2.50	1.50	0.36	0.37	0.68
	480/400	Q14025	25.00	8.88	10.50	4.44	6.50	2.50	1.50	0.36	0.37	0.68
	590/480	Q15025	25.00	8.88	10.50	4.44	6.50	2.50	1.50	0.36	0.37	0.68
30	240/200	Q12030	25.00	8.88	10.50	5.56	6.50	2.50	1.50	0.36	0.37	0.68
	480/400	Q14030	25.00	8.88	10.50	4.44	6.50	2.50	1.50	0.36	0.37	0.68
	590/480	Q15030	25.00	8.88	10.50	4.44	6.50	2.50	1.50	0.36	0.37	0.68
40	240/200	Q12040	25.00	13.00	10.50	5.56	6.50	2.62	1.50	0.36	0.37	0.68
	480/400	Q14040	25.00	13.00	10.50	5.56	6.50	2.62	1.50	0.36	0.37	0.68
	590/480	Q15040	25.00	13.00	10.50	5.56	6.50	2.62	1.50	0.36	0.37	0.68
50	480/400	Q14050	25.00	13.00	10.50	5.56	6.50	2.62	1.50	0.36	0.37	0.68
	590/480	Q15050	25.00	13.00	10.50	5.56	6.50	2.62	1.50	0.36	0.37	0.68
60	240/200	Q12060	29.00	16.64	11.85	7.14	6.88	3.12	1.50	0.44	0.49	0.92
	480/400	Q14060	29.00	16.64	11.85	7.14	6.88	3.12	1.50	0.44	0.49	0.92
	590/480	Q15060	29.00	16.64	11.85	7.14	6.88	3.12	1.50	0.44	0.49	0.92
75	480/400	Q14075	29.00	16.64	11.85	7.14	6.88	3.12	1.50	0.44	0.49	0.92
	590/480	Q15075	29.00	16.64	11.85	7.14	6.88	3.12	1.50	0.44	0.49	0.92
100	480/400	Q14100	29.00	24.42	11.85	11.12	6.50	4.50	1.50	0.44	0.49	0.92
	590/480	Q15100	29.00	24.42	11.85	11.12	6.50	4.50	1.50	0.44	0.49	0.92
125	480/400	Q14125	29.00	24.42	11.85	11.12	6.50	4.50	1.50	0.44	0.49	0.92
	590/480	Q15125	29.00	24.42	11.85	11.12	6.50	4.50	1.50	0.44	0.49	0.92
150	480/400	Q14150	29.00	36.66	11.85	SEE SECTION 4.7 - PAGE 11						
	590/480	Q15150	29.00	36.66	11.85							

4.2 QC2000 - TYPE 4/12 AND 4X ENCLOSED

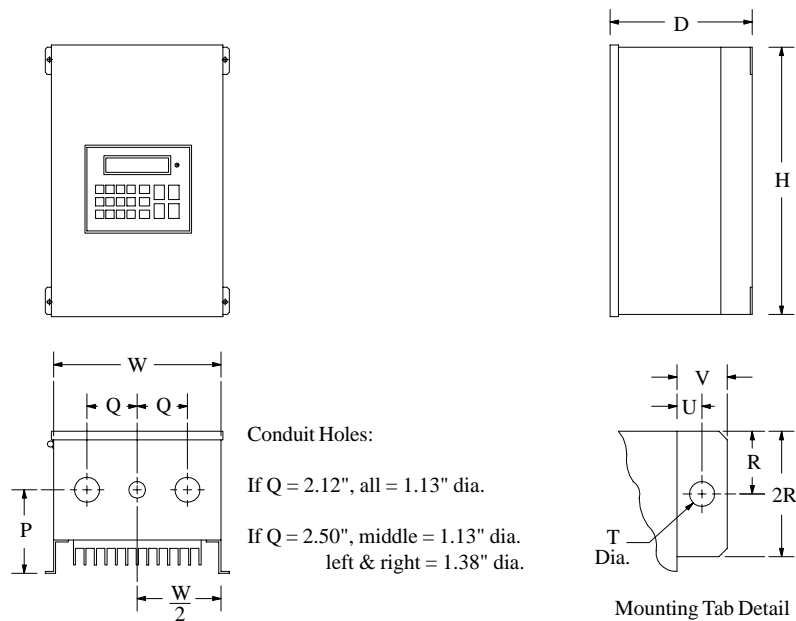

HP	INPUT VOLTAGE	MODEL	H	W	D	P	Q	R	T	U	V
1	240 / 200	Q22001	13.00	7.88	6.19	3.50	2.12	1.00	0.28	0.37	0.68
	480 / 400	Q24001	13.00	7.88	6.19	3.50	2.12	1.00	0.28	0.37	0.68
	590 / 480	Q25001	13.00	7.88	6.19	3.50	2.12	1.00	0.28	0.37	0.68
2	240 / 200	Q22002	13.00	7.88	7.25	4.56	2.12	1.00	0.28	0.37	0.68
	480 / 400	Q24002	13.00	7.88	6.19	3.50	2.12	1.00	0.28	0.37	0.68
	590 / 480	Q25002	13.00	7.88	6.19	3.50	2.12	1.00	0.28	0.37	0.68
3	240 / 200	Q22003	13.00	7.88	7.25	4.56	2.12	1.00	0.28	0.37	0.68
	480 / 400	Q24003	13.00	7.88	7.25	4.56	2.12	1.00	0.28	0.37	0.68
	590 / 480	Q25003	13.00	7.88	7.25	4.56	2.12	1.00	0.28	0.37	0.68
5	480 / 400	Q24005	16.00	9.70	7.50	4.81	2.12	1.00	0.28	0.37	0.68
	590 / 480	Q25005	16.00	9.70	7.50	4.81	2.12	1.00	0.28	0.37	0.68
7.5	240 / 200	Q22008	19.00	11.38	8.83	5.63	2.50	1.00	0.28	0.37	0.68
	480 / 400	Q24008	16.00	9.70	7.50	4.81	2.12	1.00	0.28	0.37	0.68
	590 / 480	Q25008	16.00	9.70	7.50	4.81	2.12	1.00	0.28	0.37	0.68
10	240 / 200	Q22010	19.00	11.38	8.83	5.63	2.50	1.00	0.28	0.37	0.68
	480 / 400	Q24010	19.00	11.38	8.83	5.63	2.50	1.00	0.28	0.37	0.68
	590 / 480	Q25010	19.00	11.38	8.83	5.63	2.50	1.00	0.28	0.37	0.68
15	240 / 200	Q22015	19.00	11.38	8.83	5.63	2.50	1.00	0.28	0.37	0.68
	480 / 400	Q24015	19.00	11.38	8.83	5.63	2.50	1.00	0.28	0.37	0.68
	590 / 480	Q25015	19.00	11.38	8.83	5.63	2.50	1.00	0.28	0.37	0.68
20	240 / 200	Q22020	29.00	11.74	9.78	5.88	2.50	1.50	0.36	0.37	0.68
	480 / 400	Q24020	29.00	11.74	9.78	5.88	2.50	1.50	0.36	0.37	0.68
	590 / 480	Q25020	29.00	11.74	9.78	5.88	2.50	1.50	0.36	0.37	0.68
25	240 / 200	Q22025	29.00	11.74	10.98	7.08	2.50	1.50	0.36	0.37	0.68
	480 / 400	Q24025	29.00	11.74	9.78	5.88	2.50	1.50	0.36	0.37	0.68
	590 / 480	Q25025	29.00	11.74	9.78	5.88	2.50	1.50	0.36	0.37	0.68
30	480 / 400	Q24030	29.00	11.74	10.98	7.08	2.50	1.50	0.36	0.37	0.68
	590 / 480	Q25030	29.00	11.74	10.98	7.08	2.50	1.50	0.36	0.37	0.68

4.3 QC2000 - TYPE 12 ENCLOSED

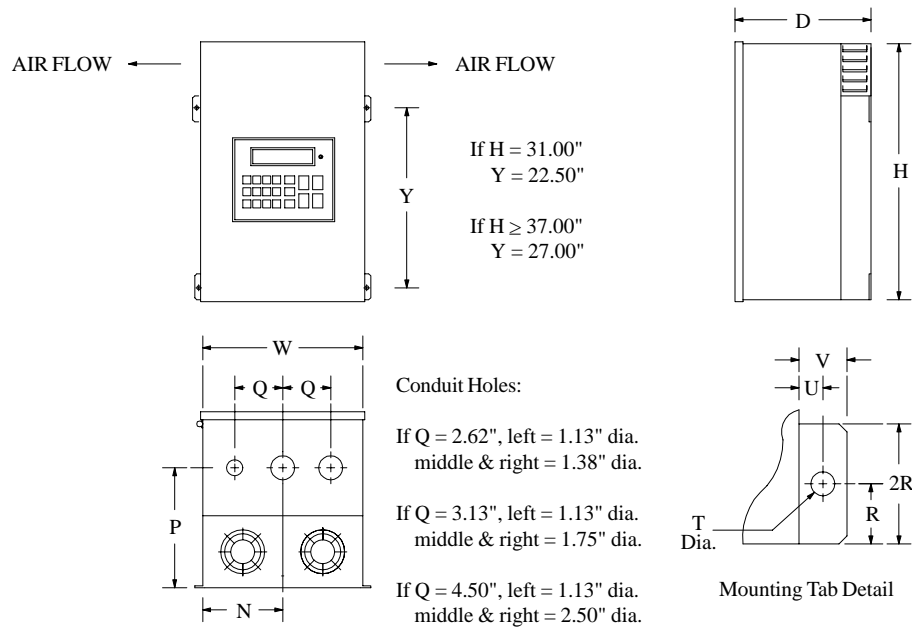

HP	INPUT		MODEL	H	W	D	N	P	Q	R	T	U	V
	VOLTAGE												
30	240/200		Q22030	31.00	14.00	11.86	6.00	7.50	2.62	1.50	0.36	0.37	0.68
40	240/200		Q22040	31.00	14.00	11.86	6.00	7.50	2.62	1.50	0.36	0.37	0.68
	480/400		Q24040	31.00	14.00	11.86	6.00	7.50	2.62	1.50	0.36	0.37	0.68
	590/480		Q25040	31.00	14.00	11.86	6.00	7.50	2.62	1.50	0.36	0.37	0.68
50	480/400		Q24050	31.00	14.00	11.86	6.00	7.50	2.62	1.50	0.36	0.37	0.68
	590/480		Q25050	31.00	14.00	11.86	6.00	7.50	2.62	1.50	0.36	0.37	0.68
60	240/200		Q22060	37.00	18.00	13.30	7.50	8.00	3.13	1.50	0.49	0.50	0.92
	480/400		Q24060	37.00	18.00	13.30	7.50	8.00	3.13	1.50	0.49	0.50	0.92
	590/480		Q25060	37.00	18.00	13.30	7.50	8.00	3.13	1.50	0.49	0.50	0.92
75	480/400		Q24075	37.00	18.00	13.30	7.50	8.00	3.13	1.50	0.49	0.50	0.92
	590/480		Q25075	37.00	18.00	13.30	7.50	8.00	3.13	1.50	0.49	0.50	0.92
100	480/400		Q24100	39.00	26.00	13.30	11.50	8.00	4.50	1.50	0.49	0.50	0.92
	590/480		Q25100	39.00	26.00	13.30	11.50	8.00	4.50	1.50	0.49	0.50	0.92
125	480/400		Q24125	39.00	26.00	13.30	11.50	8.00	4.50	1.50	0.49	0.50	0.92
	590/480		Q25125	39.00	26.00	13.30	11.50	8.00	4.50	1.50	0.49	0.50	0.92

4.4 QC3000 - CHASSIS AND TYPE 1 ENCLOSED

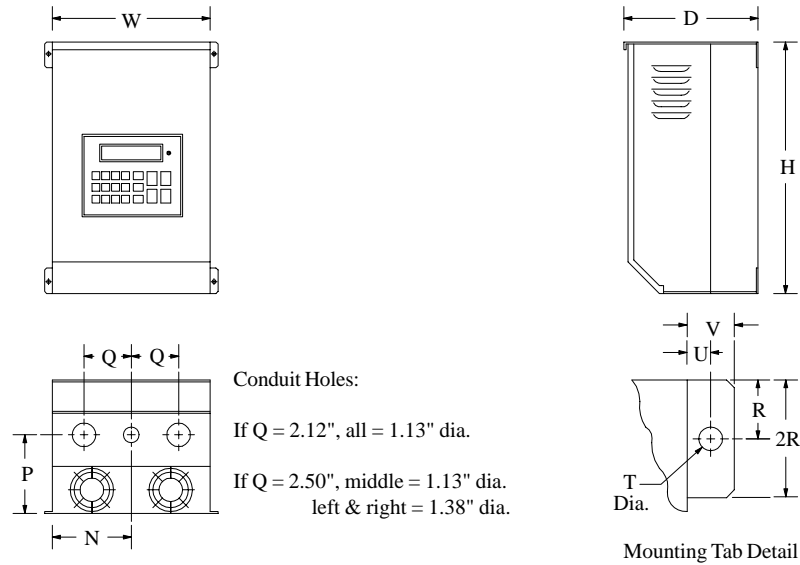

HP	INPUT VOLTAGE	MODEL	H	W	D	N	P	Q	R	T	U	V
2	240 / 200	Q32002	12.00	7.44	7.91	3.72	4.75	2.12	1.00	0.28	0.37	0.68
	480 / 400	Q34002	12.00	7.44	7.91	3.72	4.75	2.12	1.00	0.28	0.37	0.68
	590 / 480	Q35002	12.00	7.44	7.91	3.72	4.75	2.12	1.00	0.28	0.37	0.68
3	240 / 200	Q32003	12.00	7.44	7.91	3.72	4.75	2.12	1.00	0.28	0.37	0.68
	480 / 400	Q34003	12.00	7.44	7.91	3.72	4.75	2.12	1.00	0.28	0.37	0.68
	590 / 480	Q35003	12.00	7.44	7.91	3.72	4.75	2.12	1.00	0.28	0.37	0.68
5	240 / 200	Q32005	12.00	7.44	7.91	3.72	4.75	2.12	1.00	0.28	0.37	0.68
	480 / 400	Q34005	12.00	7.44	7.91	3.72	4.75	2.12	1.00	0.28	0.37	0.68
	590 / 480	Q35005	15.50	7.44	7.91	3.72	4.75	2.12	1.00	0.28	0.37	0.68
7.5	480 / 400	Q34008	12.00	7.44	7.91	3.72	4.75	2.12	1.00	0.28	0.37	0.68
	590 / 480	Q35008	15.50	7.44	7.91	3.72	4.75	2.12	1.00	0.28	0.37	0.68
10	240 / 200	Q32010	14.00	8.88	9.50	4.44	5.75	2.50	1.00	0.28	0.37	0.68
	480 / 400	Q34010	12.00	7.44	7.91	3.72	4.75	2.12	1.00	0.28	0.37	0.68
	590 / 480	Q35010	15.50	7.44	7.91	3.72	4.75	2.12	1.00	0.28	0.37	0.68
15	240 / 200	Q32015	14.00	8.88	9.50	4.44	5.75	2.50	1.00	0.28	0.37	0.68
	480 / 400	Q34015	14.00	8.88	9.50	4.44	5.75	2.50	1.00	0.28	0.37	0.68
	590 / 480	Q35015	19.00	8.88	9.84	4.44	6.13	2.50	1.00	0.28	0.37	0.68
20	240 / 200	Q32020	19.00	8.88	9.84	4.44	6.13	2.50	1.00	0.28	0.37	0.68
	480 / 400	Q34020	19.00	8.88	9.84	4.44	6.13	2.50	1.00	0.28	0.37	0.68
	590 / 480	Q35020	25.00	8.88	10.50	4.44	6.50	2.50	1.50	0.36	0.37	0.68
25	240 / 200	Q32025	25.00	8.88	10.5	4.44	6.50	2.50	1.50	0.36	0.37	0.68
	480 / 400	Q34025	25.00	8.88	10.5	4.44	6.50	2.50	1.50	0.36	0.37	0.68
	590 / 480	Q35025	25.00	8.88	10.5	4.44	6.50	2.50	1.50	0.36	0.37	0.68

4.4 QC3000 - CHASSIS AND TYPE 1 ENCLOSED

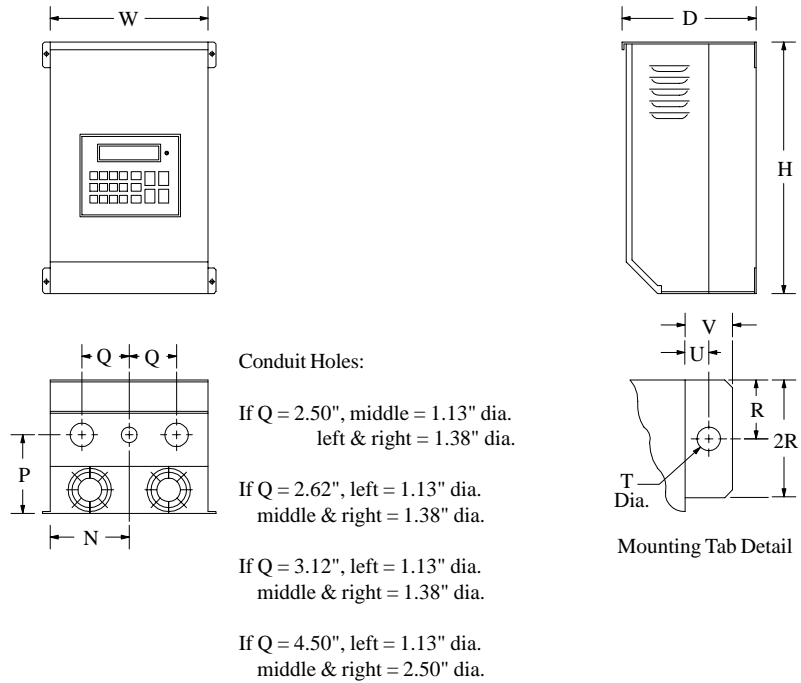

HP	INPUT VOLTAGE	MODEL	H	W	D	N	P	Q	R	T	U	V
30	240 / 200	Q32030	25.00	8.88	10.50	4.44	6.50	2.50	1.50	0.36	0.37	0.68
	480 / 400	Q34030	25.00	8.88	10.50	4.44	6.50	2.50	1.50	0.36	0.37	0.68
	590 / 480	Q35030	25.00	8.88	10.50	4.44	6.50	2.50	1.50	0.36	0.37	0.68
40	240 / 200	Q32040	25.00	13.00	10.50	5.56	6.50	2.62	1.50	0.36	0.37	0.68
	480 / 400	Q34040	25.00	13.00	10.50	5.56	6.50	2.62	1.50	0.36	0.37	0.68
	590 / 480	Q35040	25.00	8.88	10.50	5.56	6.50	2.62	1.50	0.36	0.37	0.68
50	240 / 200	Q32050	25.00	13.00	10.50	5.56	6.50	2.62	1.50	0.36	0.37	0.68
	480 / 400	Q34050	25.00	13.00	10.50	5.56	6.50	2.62	1.50	0.36	0.37	0.68
	590 / 480	Q35050	25.00	13.00	10.50	5.56	6.50	2.62	1.50	0.36	0.37	0.68
60	240 / 200	Q32060	47.00	16.64	11.85	7.14	6.88	3.12	1.50	0.44	0.49	0.92
	480 / 400	Q34060	25.00	13.00	10.50	5.56	6.50	2.62	1.50	0.36	0.37	0.92
	590 / 480	Q35060	25.00	13.00	10.50	5.56	6.50	2.62	1.50	0.36	0.37	0.92
75	240 / 200	Q32075	47.00	16.64	11.85	7.14	6.88	3.12	1.50	0.44	0.49	0.92
	480 / 400	Q34075	29.00	16.64	11.85	7.14	6.88	3.12	1.50	0.44	0.49	0.92
	590 / 480	Q35075	29.00	16.64	11.85	7.14	6.88	3.12	1.50	0.44	0.49	0.92
100	480 / 400	Q34100	29.00	16.64	11.85	7.14	6.88	3.12	1.50	0.44	0.49	0.92
	590 / 480	Q35100	29.00	16.64	11.85	7.14	6.88	3.12	1.50	0.44	0.49	0.92
125	480 / 400	Q34125	29.00	24.42	11.85	11.12	6.50	4.50	1.50	0.44	0.49	0.92
	590 / 480	Q35125	29.00	24.42	11.85	11.12	6.50	4.50	1.50	0.44	0.49	0.92
150	480 / 400	Q34150	29.00	24.42	11.85	11.12	6.50	4.50	1.50	0.44	0.49	0.92
	590 / 480	Q35150	29.00	24.42	11.85	11.12	6.50	4.50	1.50	0.44	0.49	0.92
200	480 / 400	Q34200	29.00	36.66	11.85							
	590 / 480	Q35200	29.00	36.66	11.85							
250	480 / 400	Q34250	29.00	36.66	11.85							

SEE SECTION 4.7 - PAGE 11

4.5 QC1000 AND QC3000 - CHASSIS AND TYPE 1 EXTENDED

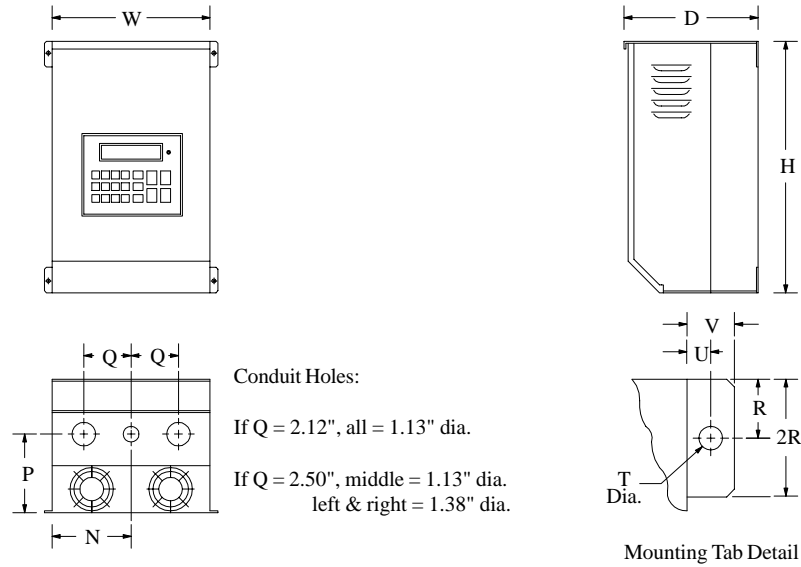

HP	INPUT VOLTAGE	MODEL	H	W	D	N	P	Q	R	T	U	V
1	240 / 200	Q12001H	15.50	7.44	7.91	3.72	4.75	2.12	1.00	0.28	0.37	0.68
	480 / 400	Q14001H	15.50	7.44	7.91	3.72	4.75	2.12	1.00	0.28	0.37	0.68
2	240 / 200	Q*2002H	15.50	7.44	7.91	3.72	4.75	2.12	1.00	0.28	0.37	0.68
	480 / 400	Q*4002H	15.50	7.44	7.91	3.72	4.75	2.12	1.00	0.28	0.37	0.68
3	240 / 200	Q*2003H	15.50	7.44	7.91	3.72	4.75	2.12	1.00	0.28	0.37	0.68
	480 / 400	Q*4003H	15.50	7.44	7.91	3.72	4.75	2.12	1.00	0.28	0.37	0.68
5	240 / 200	Q32005H	15.50	7.44	7.91	3.72	4.75	2.12	1.00	0.28	0.37	0.68
	480 / 400	Q*4005H	15.50	7.44	7.91	3.72	4.75	2.12	1.00	0.28	0.37	0.68
7.5	240 / 200	Q12008H	19.00	8.88	9.84	4.44	6.13	2.50	1.00	0.28	0.37	0.68
	480 / 400	Q14008H	15.50	7.44	7.91	3.72	4.75	2.12	1.00	0.28	0.37	0.68
		Q34008H	15.50	7.44	7.91	3.72	4.75	2.12	1.00	0.28	0.37	0.68
10	240 / 200	Q*2010H	19.00	8.88	9.84	4.44	6.13	2.50	1.00	0.28	0.37	0.68
	480 / 400	Q14010H	19.00	8.88	9.84	4.44	6.13	2.50	1.00	0.28	0.37	0.68
		Q34010H	15.50	7.44	7.91	3.72	4.75	2.12	1.00	0.28	0.37	0.68
15	240 / 200	Q*2015H	19.00	8.88	9.84	4.44	6.13	2.50	1.00	0.28	0.37	0.68
	480 / 400	Q*4015H	19.00	8.88	9.84	4.44	6.13	2.50	1.00	0.28	0.37	0.68
20	240 / 200	Q*2020H	25.00	8.88	10.50	4.44	6.50	2.50	1.50	0.36	0.37	0.68
	480 / 400	Q*4020H	25.00	8.88	10.50	4.44	6.50	2.50	1.50	0.36	0.37	0.68
25	240 / 200	Q*2025H	25.00	13.00	10.50	5.56	6.50	2.50	1.50	0.36	0.37	0.68
	480 / 400	Q*4025H	25.00	13.00	10.50	5.56	6.50	2.50	1.50	0.36	0.37	0.68
30	480 / 400	Q*4030H	25.00	13.00	10.50	5.56	6.50	2.50	1.50	0.36	0.37	0.68

NOTE: * = 1 or 3, depending on model. See Section 3.0 for model number breakdown.

4.6 QC2000 - TYPE 4/12 AND 4X EXTENDED

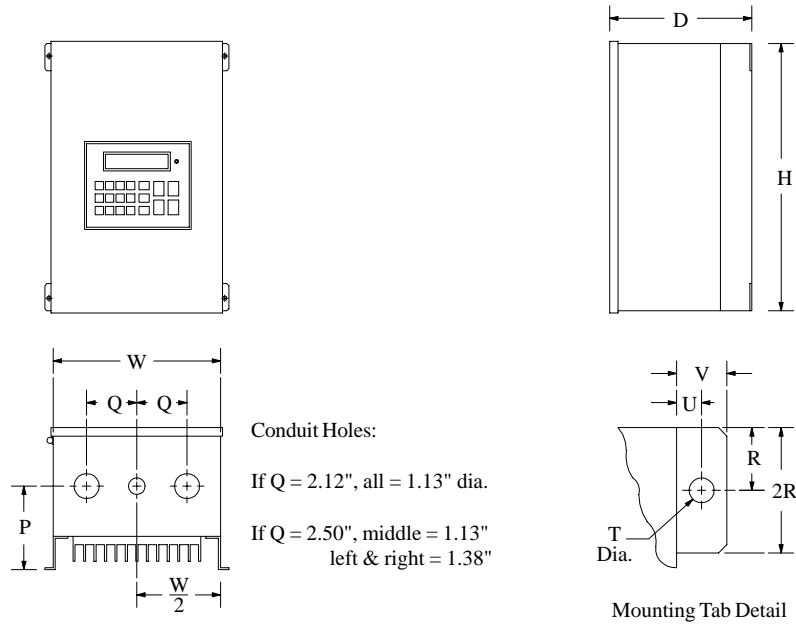

HP	INPUT		H	W	D	P	Q	R	T	U	V
	VOLTAGE	MODEL									
1	240 / 200	Q22001H	16.00	9.70	7.50	4.81	2.12	1.00	0.28	0.37	0.68
	480 / 400	Q24001H	16.00	9.70	7.50	4.81	2.12	1.00	0.28	0.37	0.68
2	240 / 200	Q22002H	16.00	9.70	7.50	4.81	2.12	1.00	0.28	0.37	0.68
	480 / 400	Q24002H	16.00	9.70	7.50	4.81	2.12	1.00	0.28	0.37	0.68
3	240 / 200	Q22003H	16.00	9.70	7.50	4.81	2.12	1.00	0.28	0.37	0.68
	480 / 400	Q24003H	16.00	9.70	7.50	4.81	2.12	1.00	0.28	0.37	0.68

4.7 MOUNTING TAB AND CONDUIT HOLE DIMENSIONS

The following diagram applies to 150 HP QC1000, 200 HP QC3000, and 250 HP QC3000 models only.

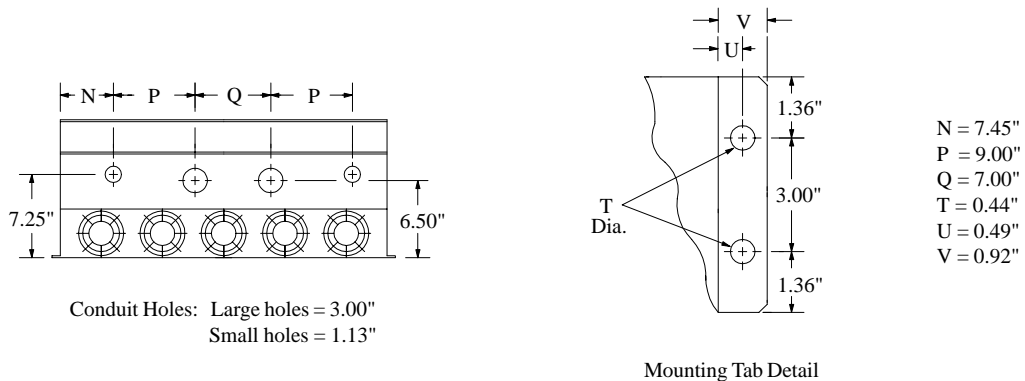

5.0 QC SERIES RATINGS

Q1200, Q2200, AND Q3200 SERIES RATINGS						
MODEL		INPUT (240 Vac, 50 - 60 Hz)			OUTPUT (0 - 230 Vac)	
MODEL NUMBER (NOTE 1)	RATED HP	INPUT PHASE	NOMINAL CURRENT (AMPS) (NOTE 2)	POWER (KVA)	NOMINAL CURRENT (AMPS)	POWER (KVA)
Q*2001	1	3	4.6	1.9	4.0	1.6
Q*2001S	1	1/3	8.5/4.6	2.0/1.9	4.0	1.6
Q*2002	2	3	8.1	3.4	6.8	2.7
Q*2002S	2	1/3	14.9/8.1	3.6/3.4	6.8	2.7
Q*2003	3	3	11.3	4.7	9.6	3.8
Q*2003S	3	1/3	21.0/11.3	5.0/4.7	9.6	3.8
Q32005	5	3	17.7	7.3	15.2	6.1
Q12008 / Q22008	7.5	3	25.0	10.5	22.0	8.8
Q*2010	10	3	32.0	13.2	28.0	11.2
Q*2015	15	3	47.6	19.8	42.0	16.7
Q*2020	20	3	61.0	25.3	54.0	21.5
Q*2025	25	3	64.0	26.6	68.0	27.1
Q*2030	30	3	76.0	31.6	80.0	31.9
Q*2040	40	3	99.0	41.0	104.0	41.4
Q32050	50	3	122.0	50.7	130.0	51.8
Q*2060	60	3	145.0	60.5	154.0	61.3
Q*2075	75	3	182.0	75.7	192.0	76.5
NOTE 1:	See Section 3.0 for model number breakdown (* = 1, 2, or 3, depending on model).					
NOTE 2:	For 200 Vac input voltage on THREE PHASE, Q1200 AND Q2200 MODELS ONLY, multiply the input and output current ratings by 1.2 and the output voltage by 0.83. For Q3200 three phase models, multiply the input and output power, and output voltage, by 0.83. Q3200 models may have to be oversized to meet the current requirements of 200 Vac applications.					
NOTE 3:	See Section 8.0 for recommended fuse type.					

Q1400, Q2400, AND Q3400 SERIES RATINGS						
MODEL		INPUT (480 Vac, 50 - 60 Hz)			OUTPUT (0 - 460 Vac)	
MODEL NUMBER (NOTE 1)	RATED HP	INPUT PHASE	NOMINAL CURRENT (AMPS) (NOTE 2)	POWER (KVA)	NOMINAL CURRENT (AMPS)	POWER (KVA)
Q*4001	1	3	2.3	1.9	2.0	1.6
Q*4002	2	3	4.0	3.4	3.4	2.7
Q*4003	3	3	5.7	4.7	4.8	3.8
Q*4005	5	3	8.8	7.3	7.6	6.1
Q*4008	7.5	3	12.6	10.5	11.0	8.8
Q*4010	10	3	15.9	13.2	14.0	11.2
Q*4015	15	3	24	19.8	21	16.7
Q*4020	20	3	31	25.4	27	21.5
Q*4025	25	3	32	26.7	34	27.1
Q*4030	30	3	38	31.5	40	31.9
Q*4040	40	3	49	41.0	52	41.4
Q*4050	50	3	61	50.7	65	51.8
Q*4060	60	3	73	60.5	77	61.3
Q*4075	75	3	91	75.5	96	76.5
Q*4100	100	3	116	96.4	124	98.8
Q*4125	125	3	146	121.4	156	124.3
Q*4150	150	3	168	139.7	180	143.4
Q34200	200	3	225	187.1	240	191.2
Q34250	250	3	281	233.6	302	240.6
NOTE 1:	See Section 3.0 for model number breakdown (* = 1, 2, or 3, depending on model).					
NOTE 2:	For 400 Vac input voltage on Q1400 AND Q2400 MODELS ONLY, multiply the input and output current ratings by 1.2 and the output voltage by 0.83. For Q3400 models, multiply the input and output power, and output voltage, by 0.83. Q3400 models may have to be oversized to meet the current requirements of 400 Vac applications.					
NOTE 3:	See Section 8.0 for recommended fuse type.					

Q1500, Q2500, AND Q3500 SERIES RATINGS						
MODEL		INPUT (590 Vac, 50 - 60 Hz)			OUTPUT (0 - 575 Vac)	
MODEL NUMBER (NOTE 1)	RATED HP	INPUT PHASE	NOMINAL CURRENT (AMPS) (NOTE 2)	POWER (KVA)	NOMINAL CURRENT (AMPS)	POWER (KVA)
Q*5001	1	3	1.8	1.9	1.6	1.6
Q*5002	2	3	3.3	3.4	2.7	2.7
Q*5003	3	3	4.6	4.7	3.9	3.9
Q*5005	5	3	5.8	5.9	6.1	6.1
Q*5008	7.5	3	8.6	8.8	9.0	8.9
Q*5010	10	3	10.6	10.9	11.0	11.0
Q*5015	15	3	16.4	16.7	17.0	16.9
Q*5020	20	3	21	21.3	22	21.5
Q*5025	25	3	26	26.9	27	26.9
Q*5030	30	3	31	31.6	32	31.9
Q*5040	40	3	40	40.5	41	40.9
Q*5050	50	3	50	51.1	52	51.8
Q*5060	60	3	60	60.9	62	61.7
Q*5075	75	3	74	75.7	77	76.7
Q*5100	100	3	95	96.6	99	98.6
Q*5125	125	3	119	121.6	125	124.5
Q*5150	150	3	137	140.0	144	143.4
Q35200	200	3	183	187.0	192	191.2
NOTE 1:	See Section 3.0 for model number breakdown (* = 1, 2, or 3, depending on model).					
NOTE 2:	For 480 Vac input voltage on Q1500 AND Q2500 MODELS ONLY, multiply the input and output current ratings by 1.23 and the output voltage by 0.81. For Q3500 models, multiply the input and output power, and the output voltage, by 0.81. Q3500 models may have to be oversized to meet the current requirements of 480 Vac applications.					
NOTE 3:	See Section 8.0 for recommended fuse type.					

6.0 THEORY

6.1 DESCRIPTION OF AC MOTOR OPERATION

Three phase AC motors are comprised of two major components, the stator and the rotor. The stator is a set of three electrical windings held stationary in the motor housing. The rotor is a metal cylinder, fixed to the motor drive shaft, which rotates within the stator. The arrangement of the stator coils and the presence of three phase AC voltage give rise to a rotating magnetic field which drives the rotor. The speed at which the magnetic field rotates is known as the synchronous speed of the motor. Synchronous speed is a function of the frequency at which the voltage is alternating and the number of poles in the stator windings.

The following equation gives the relation between synchronous speed, frequency, and the number of poles:

$$S_s = 120 f/p$$

Where: S_s = Synchronous speed (rpm), f = frequency (Hz), p = number of poles

In three phase induction motors the actual shaft speed differs from the synchronous speed as load is applied. This difference is known as "slip". Slip is commonly expressed as a percentage of synchronous speed. A typical value is three percent at full load.

The strength of the magnetic field in the gap between the rotor and stator is proportional to the amplitude of the voltage at a given frequency. The output torque capability of the motor is, therefore, a function of the applied voltage amplitude at a given frequency. When operated below base (rated) speed, AC motors run in the range of "constant torque". Constant torque output is obtained by maintaining a constant ratio between voltage amplitude (volts) and frequency (Hz). For 60 Hz, 230, 460, and 575 volt motors, common values for this V/Hz ratio are 3.83, 7.66, and 9.58 respectively. Operating with these V/Hz ratios generally yield optimum torque capability. Operating at lower ratios decreases torque and power capability. Operating at higher ratios will cause the motor to overheat. Most standard motors are capable of providing full torque output from 3 to 60 Hz. However, at lower speeds, where motor cooling fans become less effective, supplemental cooling may be needed to operate at full torque output continuously.

If the frequency applied to the motor is increased while the voltage remains constant, torque capability will decrease as speed increases. This will cause the horsepower capability of the motor to remain approximately constant. Motors run in this mode when operated above base speed, where drive output voltage is limited by the input line voltage. This operating range is known as the "constant horsepower" range. The typical maximum range for constant horsepower is about 2.3 to 1 (60 to 140 Hz). The diagram below depicts the operating characteristics of a typical AC induction motor.

WARNING!

Consult motor manufacturer before operating motor and/or driven equipment above rated speed.

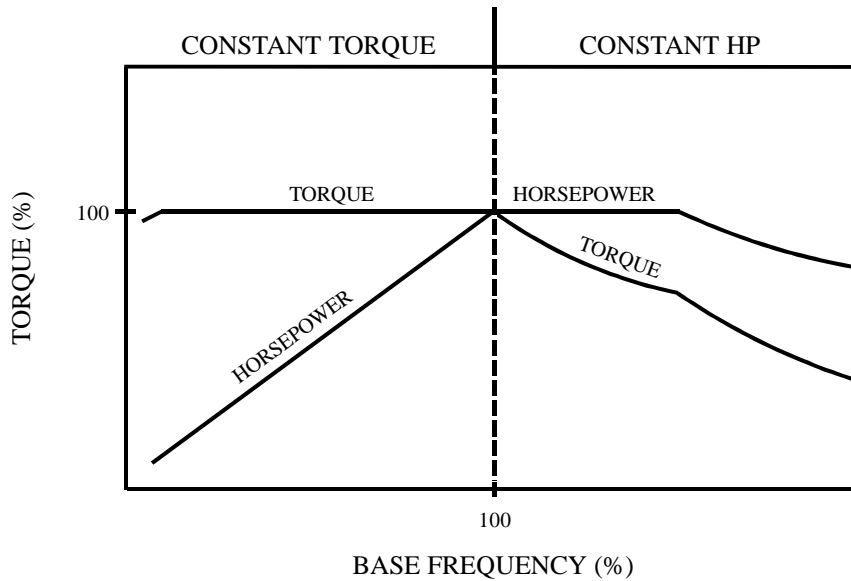

6.1.1 CONSTANT TORQUE VS. VARIABLE TORQUE

Variable frequency drives, and the loads they are applied to, can generally be divided into two groups: constant torque and variable torque. Constant torque loads include: vibrating conveyors, punch presses, rock crushers, machine tools, and just about every other application that is not considered variable torque. Variable torque loads include centrifugal pumps and fans, which make up the majority of HVAC applications.

The term *constant torque* is not entirely accurate in terms of the torque required for an application. Many constant torque applications have reciprocating loads, such as vibrating conveyors and punch presses, where the rotational motion of the motor is being converted to a linear motion. In such cases, the torque required can vary greatly at different points in the cycle. For constant torque loads, this fluctuation in torque is not a direct function of speed, as it is with a variable torque load.

Variable torque loads are governed by the affinity laws, which define the relationships between speed, flow, torque and horsepower. The diagram below illustrates these relationships:

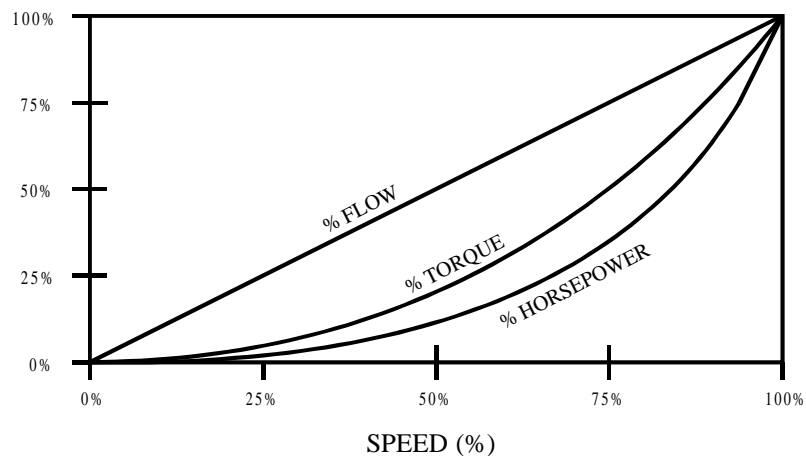

Variable torque refers to the fact that the torque required varies with the square of the speed. Also, the horsepower required varies with the cube of the speed, resulting in a large reduction in horsepower for even a small reduction in speed. It is easily seen that substantial energy savings can be achieved by reducing the speed of a fan or pump. For example, reducing the speed to 50% results in a 50 HP motor having to produce only 12.5% of rated horsepower, or 6.25 HP.

There are two major differences between a constant torque drive and a variable torque drive. One is that a constant torque drive generally has a higher overload capacity rating. Constant torque loads have higher peak torque demands, which require the ability to handle higher currents. Variable torque loads rarely experience full load, and therefore usually have a lower overload capacity. The other difference is that constant torque drives follow a constant V/Hz ratio to achieve maximum torque, while variable torque drives follow a variable V/Hz ratio to optimize efficiency and energy savings.

6.2 DRIVE FUNCTION DESCRIPTION

The QC Series is a 16 bit microprocessor based, keypad programmable, variable speed AC motor drive. There are four major sections; an input diode bridge and DC bus filter, a power board, a control board, and an output intelligent power module.

6.2.1 DRIVE OPERATION

Incoming AC line voltage is converted to a pulsating DC voltage by the input diode bridge. The DC voltage is supplied to the bus filter capacitors through a charge circuit which limits inrush current to the capacitors during power-up. The pulsating DC voltage is filtered by the bus capacitors which reduces the ripple level. The filtered DC voltage enters the inverter section of the drive, composed of six output intelligent insulated gate bi-polar transistors (IGBT's) which make up the three output legs of the drive. Each leg has one intelligent IGBT connected to the positive bus voltage and one connected to the negative bus voltage. Alternately switching on each leg, the intelligent IGBT produces an alternating voltage on each of the corresponding motor windings. By switching each output intelligent IGBT at a very high frequency (known as the carrier frequency) for varying time intervals, the inverter is able to produce a smooth, three phase, sinusoidal output current wave which optimizes motor performance.

6.2.2 CIRCUIT DESCRIPTION

The control section consists of a control board with a 16 bit microprocessor, keypad and display. Drive programming is accomplished via the keypad or the serial communications port. During operation the drive can be controlled via the keypad, by control devices wired to the control terminal strip, or by the serial communications port. The Power Board contains the control and protection circuits which govern the six output IGBT's. The Power Board also contains a charging circuit for the bus filter capacitors, a motor current feedback circuit, a voltage feedback circuit, and a fault signal circuit. The drive has several built in protection circuits. These include phase-to-phase and phase-to-ground short circuit protection, high and low line voltage protection, protection against excessive ambient temperature, and protection against continuous excessive output current. Activation of any of these circuits will cause the drive to shut down in a fault condition.

6.2.3 QC ANALOG INPUT SIGNALS

The QC Series drive allows for three speed reference input signals: speed potentiometer (10,000 Ohm), 4-20 mA, or 0-10 VDC. For control by a speed pot., the wiper lead is connected to terminal TB-5A, and the high and low end leads are connected to terminals TB-6 and TB-2, respectively. For 4-20 mA control, wire the positive to terminal TB-5B and the negative to terminal TB-2. For 0-10 VDC control, wire the positive to terminal TB-5D and the negative to terminal TB-2. See the control wiring diagram in Section 15.0.

The input impedance of terminal TB-5A (speed pot input) is 100 kilohms, TB-5B (4-20 mA input) is 100 ohms, and TB-5D (0-10 VDC input) is 200 kilohms. Terminal TB-2 is circuit common.

The control voltage of the microprocessor control board is 24 VDC, (Isolated, referenced to circuit common - terminal TB-2).

6.2.4 QC ANALOG OUTPUT SIGNALS

There are four terminals that can supply analog output signals proportional to output frequency or load. Terminal TB-10B can provide a 0-10 VDC signal proportional to frequency or load. Terminal TB-10C provides a 12 VDC pulse train proportional to frequency with a 40-50% duty cycle. Terminal TB-10D can provide a 4-20 mA signal proportional to frequency or load, and terminal TB-10E can provide a 0-10 VDC or 2-10 VDC signal proportional to frequency or load. The 2-10 VDC signal can be converted to a 4-20 mA signal using a resistor in series with the signal such that the total circuit resistance is 500 ohm. See Parameters: 50 - TB10B/D FUNCTION, and 53 - TB10E FUNCTION in Section 18.0 - DESCRIPTION OF PARAMETERS.

6.2.5 QC STATUS OUTPUT RELAYS

The control board has two FORM C relays at terminals TB-16, 17, 18, and TB-19, 20, 21. TB-16 and TB-19 are normally open contacts, and TB-18 and TB-21 are normally closed contacts. TB-17 and TB-20 are common. Contacts are rated 2 amps at 28 VDC or 120 Vac.

There is also one open-collector output at terminal TB-14. The open-collector circuit is a current-sinking type rated at 30 VDC and 40 mA maximum.

The FORM C relays and the open-collector output can be programmed to indicate any of the following: NO FUNCTION, RUN, FAULT, FAULT LOCKOUT, AT SPEED, ABOVE SET SPEED, CURRENT LIMIT, FOLLOWER PRESENT, MAINTENANCE TARGET, AUTO SPEED MODE, or START PENDING. See Parameters: 121 - RELAY #1 FUNCTION, 122 - RELAY #2 FUNCTION, and 124 - TB-14 FUNCTION, in Section 18.0 - DESCRIPTION OF PARAMETERS.

The following describes the functionality of the possible relay output settings:

NO FUNCTION	This setting disables the relay output.
RUN	The relay energizes when the drive is given a START command, and remains energized until: a STOP command is given and the output frequency has decelerated to 0.5 Hz, the drive has "tripped", or the input voltage is removed. Note that this relay indicates only that the drive is in the RUN mode. It does not necessarily indicate that the motor is turning.

FAULT	The relay energizes when input voltage is applied to the drive and remains energized until the drive “trips” into a fault condition, or input voltage is removed.
FAULT LOCKOUT	This relay can be used when the drive is programmed to automatically restart after a fault. The relay energizes when input voltage is applied to the drive and remains energized until the drive has faulted and unsuccessfully attempted the number of restarts programmed in Parameter 72 - RESTART LIMIT, or input voltage is removed.
AT SPEED	The relay energizes when the drive reaches the commanded frequency. To avoid a “chattering” relay (constantly energizing and de-energizing) due to small fluctuations in speed, the relay will change states only when the speed has changed by ± 3 Hz.
ABOVE SET SPD	ABOVE SET SPEED - The relay energizes when the output frequency of the drive exceeds the value in Parameter 123 – REL. SET SPD, and de-energizes when the output frequency is equal to or less than REL. SET SPD.
CURRENT LIMIT	The relay energizes when the drive is operating in current limit. Once the current limit relay is energized, it remains energized for a minimum of 500ms, regardless of whether the drive is still in current limit. At the end of the 500ms interval, the relay will de-energize if the drive is no longer in current limit. See Parameter 1 - CURRENT in Section 18.0 - DESCRIPTION OF PARAMETERS.
FOLLOWER PRES	FOLLOWER PRESENT - The relay energizes when the 4-20 mA speed reference input signal (TB-5B) is greater than 2 mA, and de-energizes when the signal falls below 2 mA.
MAINT. TARGET	MAINTENANCE TARGET - The relay energizes after the time period programmed in Parameter 132 - MAINTENANCE TARGET has elapsed. The relay will de-energize when a new time is programmed into Parameter 132.
AUTO SPEED MODE	The relay energizes when the drive is in the AUTOMATIC MODE, and de-energizes in the MANUAL MODE. This function is active only if Parameter 67 - AUTO/MANUAL SELECT is set to AUTO/MANUAL SPEED or AUTO/MANUAL LOCAL. The relay will remain energized if Parameter 67 is set to AUTO SPEED. This function will not be active if Parameter 67 is set to MANUAL SPEED.
START PENDING	The relay will energize if the drive has faulted, and is programmed for automatic restart after a fault. START PENDING will appear on the keypad display when the drive is in this condition. The relay will de-energize after the delay programmed into Parameter 73 - RESTART DELAY, at which time the drive will attempt to restart.

7.0 INSTALLATION

WARNING!

DRIVES MUST NOT BE INSTALLED WHERE SUBJECTED TO ADVERSE ENVIRONMENTAL CONDITIONS! DRIVES MUST NOT BE INSTALLED WHERE SUBJECTED TO: COMBUSTIBLE, OILY, OR HAZARDOUS VAPORS OR DUST; EXCESSIVE MOISTURE OR DIRT; STRONG VIBRATION; EXCESSIVE AMBIENT TEMPERATURES. CONSULT AC TECHNOLOGY FOR MORE INFORMATION ON THE SUITABILITY OF A DRIVE TO A PARTICULAR ENVIRONMENT.

The drive should be mounted on a smooth vertical surface capable of safely supporting the unit without vibrating. The LCD display has an optimum field of view, this should be considered when determining the mounting position.

Chassis models must be installed in an electrical enclosure which will provide complete mechanical protection and maintain uniform internal temperature within the drive's ambient operating temperature rating. All drive models MUST be mounted in a vertical position for proper heatsink cooling.

Maintain a minimum spacing around the drive of 4 inches for units rated 20 HP and below, 6 inches for units rated 25-50 HP, and 8 inches for units rated 60 HP and above.

Fans or blowers should be used to insure proper cooling in tight quarters. Do not mount drives above other drives or heat producing equipment that would impede the cooling of the drive. Note the ambient operating temperature ratings for each drive model.

If it is necessary to drill or cut the drive enclosure or panel, extreme care must be taken to avoid damaging drive components or contaminating the drive with metal fragments (which cause shorting of electrical circuits). Cover drive components with a clean cloth to keep out metal chips and other debris. Use a vacuum cleaner to clean drive components after drilling, even if chips do not appear to be present. Do not attempt to use positive air pressure to blow chips out of drive, as this tends to lodge debris under electronic components. Contaminating the drive with metal chips can cause drive failure and will void the warranty.

7.1 INSTALLATION AFTER A LONG PERIOD OF STORAGE

WARNING!

Severe damage to the drive can result if it is operated after a long period of storage or inactivity without reforming the DC bus capacitors!

If input power has not been applied to the drive for a period of time exceeding one year (due to storage, etc), the electrolytic DC bus capacitors within the drive can change internally, resulting in excessive leakage current. This can result in premature failure of the capacitors if the drive is operated after such a long period of inactivity or storage.

In order to reform the capacitors and prepare the drive for operation after a long period of inactivity, apply input power to the drive for 2 hours prior to actually operating the drive/motor system.

7.2 EXPLOSION PROOF APPLICATIONS

Explosion proof motors that are not rated for inverter use lose their certification when used for variable speed. Due to the many areas of liability that may be encountered when dealing with these applications, the following statement of policy applies:

"AC Technology Corporation inverter products are sold with no warranty of fitness for a particular purpose or warranty of suitability for use with explosion proof motors. AC Technology Corporation accepts no responsibility for any direct, or incidental or consequential loss, cost, or damage that may arise through the use of its AC inverter products in these applications. The purchaser expressly agrees to assume all risk of any loss, cost, or damage that may arise from such application. AC Technology Corporation or AC Technology Corporation's engineering department will not knowingly approve applications involving explosion proof motors."

8.0 INPUT AC POWER REQUIREMENTS

WARNING!

Hazard of electrical shock! Disconnect incoming power and wait three minutes before servicing the drive. Capacitors retain charge after power is removed.

8.1 INPUT AC POWER REQUIREMENTS

8.1.1 VOLTAGE:

The system line voltage must match the drive's input voltage rating. Voltage fluctuation must not vary by greater than 10% overvoltage or 15% undervoltage.

NOTE: Drives with dual rated input voltage must be programmed for the proper supply voltage - see Parameter 94 - AC INPUT in Section 18.0 - DESCRIPTION OF PARAMETERS SECTION.

The drive is suitable for use on a circuit capable of delivering not more than 200,000 RMS symmetrical amperes, at the drive's rated voltage.

Three phase voltage imbalance must be less than 2.0% phase to phase. Excessive phase to phase imbalance can cause severe damage to the drive's power components.

Motor voltage should match line voltage in normal applications. The drive's maximum output voltage will equal the input voltage. Use extreme caution when using a motor with a voltage rating which is different from the input line voltage.

8.1.2 kVA RATINGS:

If the kVA rating of the AC supply transformer is greater than ten times the input kVA rating of the drive, a drive isolation transformer, or a 2 - 3% input line reactor (also known as a choke) must be added. This only applies to 240/200 Vac and 480/400 Vac models rated 20 HP and below, and 590/480 Vac models rated 3 HP and below, as larger units have standard built-in line reactors.

8.2 INPUT FUSING AND DISCONNECT REQUIREMENTS

A circuit breaker or a disconnect switch with fuses must be provided in accordance with the National Electric Code (NEC) and all local codes.

The QC1000 and QC2000 drives are capable of withstanding up to 150% current overload for 60 seconds, and the QC3000 is capable of 120% current overload for 60 seconds. Therefore, select a fuse or magnetic trip circuit breaker rated at a maximum of 1.5 (QC1000/2000), or 1.25 (QC3000) times the input current rating of the drive. Refer to Section 5.0 - DRIVE RATINGS.

Minimum voltage rating of the protection device should be: 250 Vac for 240/120 Vac and 240/200 Vac rated drives, and 600 Vac for 480/400 Vac and 590/480 Vac drives.

If using fuses, current limiting fuses should be used. Select fuses with low I²T values, rated at 200,000 AIC. Recommended fuses are Bussman type KTK-R and JJN for 240/200 Vac models, or type KTK-R and JJS for 480/400 Vac and 590/480 Vac models. Similar fuses with equivalent ratings by other manufacturers may also be acceptable.

9.0 VOLTAGE SELECTION

WARNING!

Before applying incoming line voltage, verify that the proper voltage is selected at PL1 or PL2. FAILURE TO PROPERLY SELECT THE INPUT VOLTAGE MAY RESULT IN DRIVE DAMAGE!

9.1 INPUT RATINGS

Q*200 drives are rated for 240/200 Vac, 50-60 Hz input. With the proper voltage selection, the drive will function with input power of 240 Vac (+10%, -15%) or 200 Vac (+10%, -15%), at 48 to 62 Hz.

Q*400 drives are rated for 480/400 Vac, 50-60 Hz input. With the proper voltage selection, the drive will function with input power of 480 Vac (+10%, -15%) or 400 Vac (+10%, -15%), at 48 to 62 Hz.

Q*500 drives are rated for 590/480 Vac, 50-60 Hz input. With the proper voltage selection, the drive will function with input power of 590 Vac (+10%, -15%) or 480 Vac (+10%, -15%), at 48 to 62 Hz.

NOTE: * = 1, 2, or 3, depending on model. Refer to Section 3.0 for model number breakdown.

NOTE: QC3000 units must be derated for operation at 200 Vac, 400 Vac, or 480 Vac (on 590 Vac models) input voltage. Refer to Section 5.0 for drive ratings.

9.2 VOLTAGE SELECTION

To select the proper voltage on 1, 2, and 3 HP, 240/200 Vac drives, the PL1 plug must be in the correct position. PL1 is located in the lower right corner of the power board. Refer to the diagrams below.

For all other units, the PL2 plug is used to select the correct input voltage. Plug PL2 into the top and middle pins to select 240, 480, or 590 Vac, or the middle and bottom pins to select 200, 400, or 480 (on Q*500 models) Vac input. PL2 is located either at the lower right corner, or upper right corner of the power board, depending on horsepower.

NOTE: In addition to the voltage plug selection, Parameter 94 - AC INPUT must also be programmed for the proper voltage. See Section 18.0 - DESCRIPTION OF PARAMETERS.

VOLTAGE SELECTION PLUG

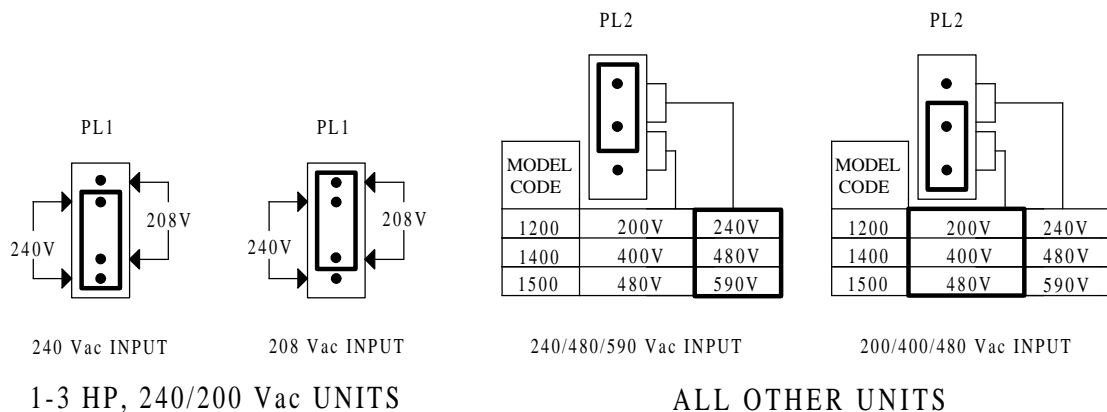

10.0 POWER WIRING

WARNING!

Hazard of electrical shock! Disconnect incoming power and wait three minutes before servicing the drive. Capacitors retain charge after power is removed.

Note drive input and output current ratings and check applicable electrical codes for required wire type and size, grounding requirements, over-current protection, and incoming power disconnect, before wiring the drive. Size conservatively to minimize the voltage drop.

Input fusing and a power disconnect switch or contactor **MUST** be wired in series with terminals L1, L2, and L3 (L1 and L2 if input is single phase). If one has not been supplied by AC Technology Corporation, a disconnect means must be wired during installation. This disconnect must be used to power down the drive when servicing, or when the drive is not to be operated for a long period of time, but should not be used to start and stop the motor. Repetitive cycling of a disconnect or input contactor (more than once every two minutes) may cause damage to the drive.

10.1 WIRING FOR SINGLE PHASE OR THREE PHASE INPUT

If the drive is nameplated for single phase input only, wire input to terminals L1 and L2.

If the drive is nameplated for single or three phase input, wire input to terminals L1 and L2, and jump L2 to L3 for single phase input, or wire input to L1, L2, and L3 for three phase input.

If the drive is nameplated for three phase input only, wire input to terminals L1, L2, and L3.

All three power output wires, from terminals T1, T2, and T3 to the motor, must be kept tightly bundled and run in a separate conduit away from all other wiring.

It is not recommended to install contactors or disconnect switches between the drive and motor. Operating such devices while the drive is running can potentially cause damage to the drive's power components. If such a device is required, it should only be operated when the drive is in a STOP state. If there is potential for the device to be opened while the drive is running, the drive must be programmed for COAST TO STOP (see Parameter 65 - COAST STOP), and an auxiliary contact on the device must be interlocked with the drive's run circuit. This will give the drive a stop command at the same time the device opens, and will not allow the drive to start again until the device is closed.

11.0 QC SERIES POWER WIRING DIAGRAM

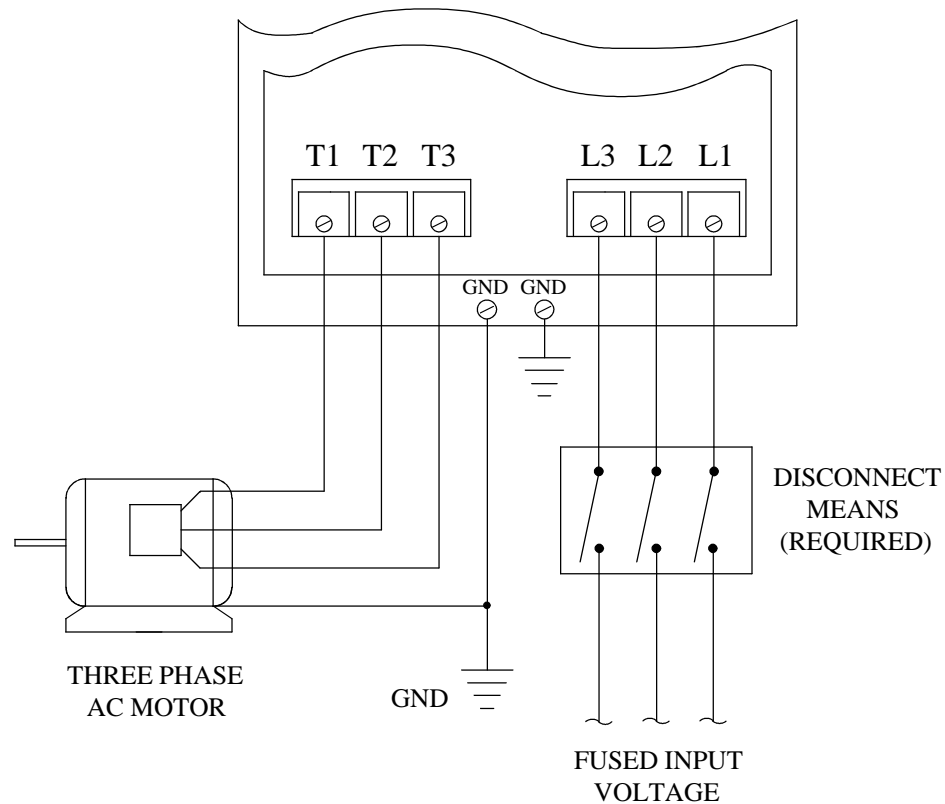

WARNING!

Do not connect incoming AC power to output terminals T1, T2, or T3. Severe damage to the drive will result.

INSTALL, WIRE, AND GROUND IN ACCORDANCE WITH ALL APPLICABLE CODES.

NOTES:

1. Wire the motor for the proper voltage per the output rating of the drive. Motor wires **MUST** be run in a separate steel conduit away from control wiring and incoming AC power wiring.
2. Do not install contactors between the drive and the motor without consulting AC Technology for more information. Failure to do so may result in drive damage.
3. Remove any existing, and do not install, power factor correction capacitors between the drive and the motor. Failure to do so will result in drive damage.
4. Use only UL and CSA listed and approved wire.
5. Minimum wire voltage ratings: 300 V for 120, 200 and 240 Vac systems, and 600 V for 400, 480, and 590 Vac systems.
6. Input/output wire gauge must be based on a minimum of either 150% (QC1000/2000) or 125% (QC3000) of the rated input/output current of the drive, and a minimum 75°C insulation rating. Use copper wire only.
7. Wire and ground in accordance with NEC or CEC, and all applicable local codes.

12.0 INITIAL POWER UP

WARNING!

Hazard of electrical shock! Disconnect incoming power and wait three minutes before servicing drive. Capacitors retain charge after power is removed.

Before attempting to operate the drive, motor, and driven equipment be sure all procedures pertaining to installation and wiring have been properly followed. Before powering up the drive for the first time, wire the drive for operation via the keypad (see Section 13.0 - KEYPAD CONTROL), then follow the procedures below.

WARNING!

Severe damage to the drive can result if it is operated after a long period of storage or inactivity without reforming the DC bus capacitors!

If input power has not been applied to the drive for a period of time exceeding one year (due to storage, etc), the electrolytic DC bus capacitors within the drive can change internally, resulting in excessive leakage current. This can result in premature failure of the capacitors if the drive is operated after such a long period of inactivity or storage.

In order to reform the capacitors and prepare the drive for operation after a long period of inactivity, apply input power to the drive for 2 hours prior to actually operating the drive/motor system.

Disconnect the driven load from the motor. Verify that the drive input terminals (L1, L2, and L3) are wired to the proper input voltage per the nameplate rating of the drive.

WARNING!

Incoming AC power MUST NOT be connected to output terminals T1, T2, and T3! Do not cycle input power to the drive more than once every two minutes.

Energize the incoming power line. The LCD display should light and flash TESTING and the voltage and horsepower rating of the drive. The display should then show the following:

STOP	20.00	HZ
0% LOAD	FWD	KEY

This display indicates that the drive is stopped, the present speed setpoint is 20.00 Hz, there is no load on the drive (because it is stopped), forward rotation is selected, and speed control is from the keypad. If the display does not appear, remove the incoming power, wait three minutes for the bus capacitors to discharge, and verify correct installation and wiring. If the wiring is correct, re-apply incoming power and note the display for drive status. If the display still does not appear, refer to Section 20.0 - TROUBLESHOOTING, or call the factory for assistance. If the drive powers up correctly, follow the procedure given below to check the motor rotation:

1. Use the DOWN arrow key to decrease the speed setpoint to the minimum value allowed (0.50 Hz if Parameter 61 - MINIMUM FREQ has not been changed).
2. Press the START key. The drive should indicate RUN, but if the speed setpoint is 0.50 Hz, the motor may not rotate. Press the UP arrow key to increase the speed setpoint until the motor starts to rotate.
3. If the motor is spinning in the wrong direction, press the STOP key, remove power from the drive, wait three minutes for the bus capacitors to discharge, and swap any two of the motor wires connected to T1, T2, and T3.

NOTE: The drive is phase insensitive with respect to incoming line voltage. Therefore, to change the motor rotation, the phasing must be swapped at the drive output terminals or at the motor.

13.0 KEYPAD CONTROL

The drive can be operated by the keypad (local), by control devices wired to the terminal strip (remote), by serial communications, or by a combination of the terminal strip and either the keypad or serial communications. The drive should be first operated from the keypad during initial start up. Refer to Sections 14.0 - CONTROL WIRING, and 18.0 - DESCRIPTION OF PARAMETERS for information on remote operation.

13.1 SETTING THE DRIVE FOR KEYPAD CONTROL

To operate by keypad control, three terminals on the main control board need to be closed to common. Refer to the terminal strip diagram below:

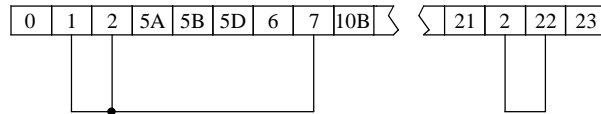

1. Close TB-1 to TB-2 (common) to de-activate the remote STOP input. The remote STOP function is always active, even in the LOCAL mode.
2. Close TB-7 to TB-2 to select LOCAL (keypad control) mode.
3. Close TB-22 to TB-2 to de-activate the emergency stop (E-stop) input. The E-stop function is always active, even in LOCAL mode.

13.2 KEYPAD FUNCTIONS IN LOCAL MODE

START/STOP Press the **START** key to start the drive, and press the **STOP** key to stop the drive.

NOTE: The **STOP** key is active in both local and remote mode.

SPEED CONTROL The speed setpoint can be changed using either the **UP** and **DOWN** arrow keys, or the numeric keys. Use the arrow keys to scroll to the desired speed setpoint, or use the numeric keys to directly input the speed setpoint. When using the arrow keys, the drive will begin accelerating or decelerating (if the drive is running) as the speed setpoint is being changed. If the numeric keys are used however, the new setpoint will not take effect until the **ENTER** key is pressed.

JOG To enter the keypad jog mode, press the **JOG** key while holding down the **STOP** key, and then release both keys. "JOG" will appear in the speed reference portion of the display. The drive will now jog when the **JOG** button is pressed. The jog speed is determined by Parameter 19 - **JOG SPEED**. Press any key other than **JOG** to exit the jog mode.

FORWARD/REVERSE To change rotation direction, press the FWD/REV key and then press the ENTER key.

NOTE: Parameter 66 - FWD/REV must be set to FWD + REV for this key to be active. The factory default setting is FWD ONLY.

SPEED REFERENCE To toggle between MANUAL speed control and AUTOMATIC speed control, press the AUTO/MAN key and then press ENTER.

NOTE: Parameter 67 - AUTO/MANUAL SEL must be set to AUTO/MANUAL SPEED or AUTO/MANUAL LOCAL for this key to be active. See Section 14.0 - CONTROL WIRING for information on automatic speed references.

CLEARING ERRORS Press the CLEAR key to clear any errors made while entering data.

13.3 QC SERIES DISPLAY (NORMAL)

The following diagram illustrates the normal QC Series display when the drive is in the STOP mode:

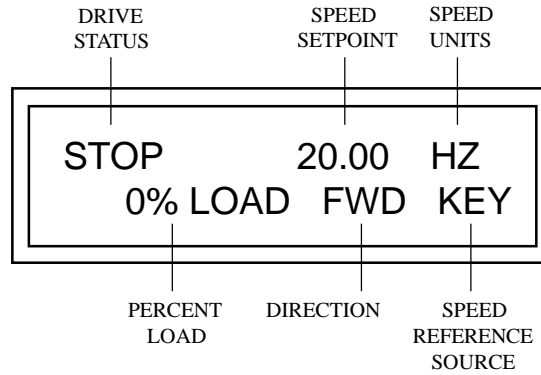

The display shown above indicates that the drive is stopped, the present speed setpoint is 20 Hz, there is no load (because it is stopped), the forward direction is selected, and the speed reference source is the keypad.

The display below shows the drive in the RUN mode. The drive is operating at 20 Hz, and there is now a load on the motor. All other indications remain the same. See the tables below for the possible DRIVE STATUS and SPEED REFERENCE SOURCE indications.

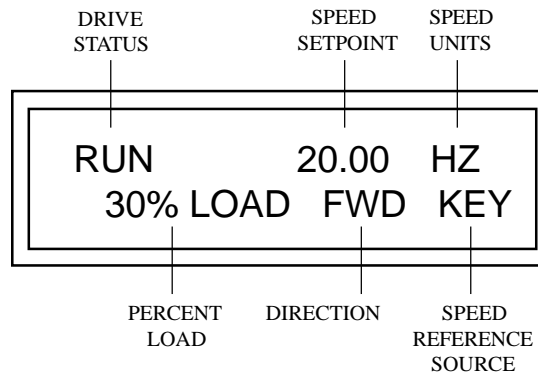

The following tables describes the possible DRIVE STATUS and SPEED REFERENCE SOURCE indications that can appear on the display:

DRIVE STATUS INDICATIONS	
DISPLAY	DESCRIPTION
STOP	Drive is in STOP mode - No output to the motor.
RUN	Drive is in RUN mode and is within +/- 3 Hz of the speed setpoint.
RUN@0	Drive is in RUN mode, with a 0 Hz speed setpoint.
ACCEL	Drive is accelerating to the speed setpoint.
DECEL	Drive is decelerating to the speed setpoint. If DECEL is flashing, the drive has stopped decelerating to avoid a HI BUS VOLTS fault.
FAULT	Drive has tripped into a protective FAULT. If the fault condition has passed, pressing the STOP key, or opening TB-1 to TB-2 will clear the fault and return the drive to the STOP mode.
FAULT LOCKOUT	The programmed number of restarts were attempted, but were unsuccessful. Requires a manual reset as described above for FAULT.
BRAKE	DC BRAKE is energized.
C LIM	Drive is in CURRENT LIMIT due to an overloaded motor, or ACCEL is too fast.

SPEED REFERENCE SOURCE INDICATIONS	
DISPLAY	DESCRIPTION
KEY	KEYPAD - UP and DOWN arrow keys or direct numeric entry.
JOG	JOG: Close TB-12D to TB-2 to JOG, open to STOP. Jog speed is set by Parameter 19 - JOG SPEED.
POT	SPEED POT at TB-5A.
A-C	AUTO - CURRENT: 4-20 mA at TB-5B.
A-V	AUTO - VOLTAGE: 0-10 VDC at TB-5D.
S-1 to S-7	PRESET SPEED #1 - 7: Parameters 11-17.

13.4 QC SERIES DISPLAY (ACTUAL SPEED)

The following diagram shows the QC Series display in the ACTUAL SPEED mode. This mode can be activated by Parameter 133 - DISPLAY FUNCTION. Instead of displaying the drive status, or the word LOAD, the ACTUAL SPEED display will indicate the actual running speed, and whether the drive is in LOCAL (LOC), REMOTE (REM), or SERIAL (SER) control mode.

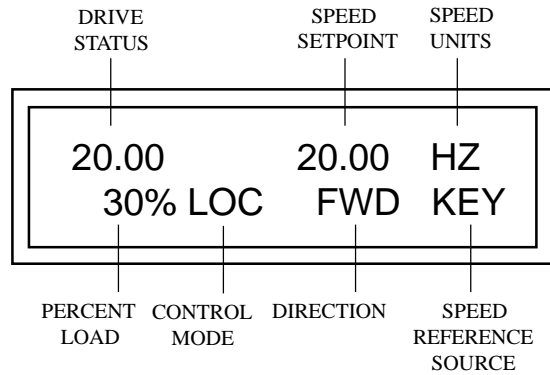

13.5 MONITOR MODE

The QC Series MONITOR MODE allows the user to display four functions: TIME SINCE START, TOTAL RUN TIME, TOTAL KW HOURS, and HOURS TIL MAINT.

TIME SINCE START displays the time that the drive has been running since the last start command. This will reset each time the drive is given a start command, or if power is removed from the drive.

TOTAL RUN TIME displays the total elapsed time that the drive has operated since it was started the first time. This value is non-resettable.

TOTAL KILOWATT HOURS displays the total elapsed kilowatt-hours, calculated from the total run time, motor current, and voltage. Parameter 130 - DRIVE POWER must be set to the drive's horsepower rating for this function to be enabled. This value is non-resettable.

HOURS UNTIL MAINTENANCE displays the time remaining until the MAINTENANCE TARGET (Parameter 132) is reached. This parameter can be used to indicate when maintenance needs to be performed on the driven equipment (gear box lubrication, replace belts, etc). Parameter 132 - MAINTENANCE TARGET must be set to a value greater than zero for this function to be enabled.

To view the MONITOR MODE displays, press the ENTER key while viewing the operation display. Pressing the ENTER key once will display TIME SINCE START. Pressing ENTER a second time will display TOTAL RUN TIME, etc. Pressing ENTER while viewing HOURS UNTIL MAINTENANCE will return the user to the normal operation display. MONITOR MODE examples are shown below:



13.6 QC SERIES FAULT DISPLAY

When the QC Series drive faults, the normal operation display will change to a fault display that indicates the type of fault, the drive status at the time of the fault, and the time at which the fault occurred. This display is part of the MONITOR MODE (see Section 13.5), but only appears if a fault condition exists. An example of the fault display is shown below:

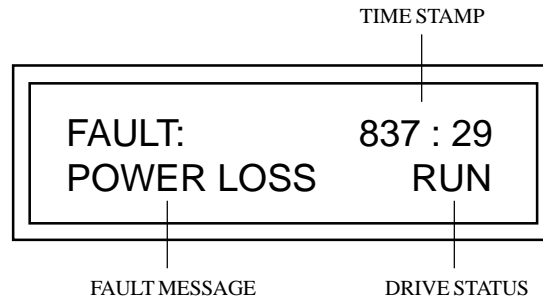

The fault display above indicates that the drive tripped on a POWER LOSS fault that occurred at 837:29 on the run time meter, and the drive was in a RUN state when it faulted. Refer to Section 20.0 - TROUBLESHOOTING for a list of the possible fault messages that can appear on the display.

There are three methods of clearing a FAULT:

1. Press the STOP key on the keypad.
2. Open the STOP input at TB-1 on the terminal strip.
3. Remove power from the unit, wait one minute, then re-apply power.

NOTE: A FAULT can only be cleared if the condition that caused the fault has been corrected. For example, if the drive trips on a LOW VOLTS fault due to low input power, the fault cannot be reset until the input power has returned to the proper level.

14.0 CONTROL WIRING

14.1 GENERAL

14.1.1 KEYPAD CONTROL

The drive can be controlled by the keypad or by control devices wired to the terminal strip. To operate the drive from the keypad, refer to Section 13.0 - KEYPAD CONTROL.

14.1.2 CONTROL WIRING VS. POWER WIRING

External control wiring **MUST** be run in a separate conduit away from all other input and output power wiring. If control wiring is not kept separate from power wiring, electrical noise may be generated on the control wiring that could cause erratic drive behavior, possibly resulting in damage to the drive. Use twisted wires or shielded cable grounded at the drive chassis **ONLY**.

14.1.3 TB-2: CIRCUIT COMMON

The TB-2 terminals are used as circuit common for the start/stop, forward/reverse, jog, local/remote, analog input, analog output, and E-stop functions. There are two TB-2 terminals available on the terminal strip, and they are internally connected to each other on the main control board. If necessary TB-2 may be connected to chassis ground.

14.1.4 SURGE SUPPRESSION ON RELAYS

Current and voltage surges and spikes in the coils of contactors, relays, solenoids, etc, near or connected to the drive, can cause erratic drive operation. Therefore, a snubber circuit should be used on coils associated with the drive. For AC coils, snubbers should consist of a resistor and a capacitor in series across the coil. For DC coils, a free-wheeling or flyback diode should be placed across the coil. Snubbers are typically available from the manufacturer of the device.

14.2 REMOTE CONTROL

14.2.1 REMOTE MODE SELECTION

To select the REMOTE mode, **DO NOT** close terminal TB-7 to TB-2. Closing TB-7 to TB-2 will select the LOCAL mode.

14.2.2 TWO-WIRE START/STOP CONTROL

A two-wire (maintained contact) start/stop circuit can be accomplished by one of two methods on the QC Series drive. Follow the appropriate procedure listed below:

FORWARD ROTATION ONLY

1. Select REMOTE mode (see above).
2. Connect a jumper between TB-12A and TB-2 to provide a permanent START command to the drive.

3. Connect a jumper between TB-12B and TB-2 to select FORWARD rotation.
4. Wire a normally open maintained contact between TB-1 and TB-2. Close this contact to START the drive, and open this contact to STOP the drive.

FORWARD and REVERSE ROTATION

1. Select REMOTE mode (see above).
2. Program Parameter 66 - ROTATION to FWD + REV to allow rotation in both directions.
3. Connect a jumper between TB-12A and TB-2 to provide a permanent START command to the drive.
4. Select the desired rotation by closing the appropriate terminal (TB-12B for forward, or TB-12C for reverse) to TB-2. This can be done with a toggle switch or equivalent circuit.
5. Wire a normally open maintained contact between TB-1 and TB-2. Close this contact to START the drive, and open this contact to STOP the drive.

Refer to Section 15.2 for a diagram illustrating a typical two-wire start/stop control.

14.2.3 ALTERNATE START/STOP CONTROL METHOD

This method uses the direction selection contacts (TB-12B and TB-12C) to start and stop the drive. This is used when only two dry contacts are available and the user needs to control start/stop and direction functions.

1. Select REMOTE mode (see above).
2. Connect a jumper between TB-1 and TB-2 to de-activate the STOP input.
3. Connect a jumper between TB-12A and TB-2 to provide a permanent START command to the drive.
4. ENABLE Parameter 70 - AUTO START, or Parameter 71 - RESTART ON FAULT. This will put the drive into the RUN mode when power is applied. RUN will be flashing and three flashing question marks (???) will appear in the DIRECTION portion of the display.
5. Wire a normally open maintained contact between TB-12B and TB-2. Close this contact to START the drive in FORWARD, and open this contact to STOP the drive.
6. Wire a normally open maintained contact between TB-12C and TB-2. Close this contact to START the drive in REVERSE, and open this contact to STOP the drive.

NOTE: When a connection is made between TB-2 and either TB-12B (forward), or TB-12C (reverse) to start the drive, the flashing question marks will be replaced by the selected direction indication (FWD or REV), and the flashing RUN will change to ACCEL as the drive accelerates to the speed setpoint. When the connection is opened to stop the drive, the DRIVE STATUS indication will change to DECEL, and the DIRECTION indication will change back to the three flashing question marks. When the drive reaches the end of the deceleration ramp, the flashing question marks will remain, and the DRIVE STATUS indication will return to the flashing RUN.

Refer to Section 15.3 for a diagram illustrating the alternate start/stop control.

14.2.4 THREE-WIRE START/STOP CONTROL

A three-wire (momentary contacts) start/stop circuit can be accomplished by following the appropriate procedure listed below:

FORWARD ROTATION ONLY

1. Select REMOTE mode (see above).
2. Connect a jumper between TB-12B and TB-2 to select the FORWARD direction.
3. Wire a normally closed momentary contact between TB-1 and TB-2. This is the STOP input. Open this contact to STOP the drive.
4. Wire a normally open momentary contact between TB-12A and TB-2. Close this contact to START the drive.

FORWARD and REVERSE ROTATION

1. Select REMOTE mode (see above).
2. Program Parameter 66 - FWD / REV to FWD + REV.
3. Select the desired rotation by closing the appropriate terminal (TB-12B for forward, or TB-12C for reverse) to TB-2. This can be done with a toggle switch or equivalent circuit.
4. Wire a normally closed momentary contact between TB-1 and TB-2. Open this contact to STOP the drive.
5. Wire a normally open momentary contact between TB-12A and TB-2. Close this contact to START the drive.

NOTE: If the opposite direction is selected while the drive is running, the drive will decelerate to 0 Hz and then accelerate back to the speed setpoint in the opposite direction.

Refer to Section 15.4 for a diagram illustrating a typical three-wire start/stop control.

14.2.5 ANALOG SPEED REFERENCE SIGNALS

The drive allows for three analog speed reference inputs: a speed potentiometer (10 kilohm), 0-10 VDC, or 4-20 mA.

SPEED POT Connect the wiper to terminal TB-5A, and connect the high and low end leads to terminals TB-6 and TB-2, respectively.

0-10 VDC Wire the positive to terminal TB-5D and the negative to terminal TB-2.

4-20 mA Wire the positive to terminal TB-5B and the negative to terminal TB-2.

The input impedance of terminal TB-5A (speed pot input) is 100 kilohms, terminal TB-5B (4-20 mA input) is 100 Ohms, and terminal TB-5D (0-10 VDC) is 200 kilohms. Terminal TB-2 is circuit common.

NOTE: TB-10B and TB-10D are not independent. They are both controlled by Parameter 50 - TB10B/D FUNC. If a 0-10 VDC signal is required, program Parameter 50 to 0-10 V FREQ or 0-10 V LOAD, and use TB-10B. If a 4-20 mA signal is required, program Parameter 50 to 4-20 MA FREQ or 4-20 MA LOAD, and use TB-10D.

14.2.8 DRIVE STATUS OUTPUT CONTACTS

The control board has two FORM C relays at terminals TB-16, 17, and 18, and TB-19, 20, and 21. Contacts are rated 2 amps at 28 VDC or 120 Vac.

There is also an open-collector output at terminal TB-14. The open-collector circuit is a current-sinking type rated at 30 VDC and 40 mA maximum. An external 24 VDC power supply must be used to power the open-collector output. The drive does not have a dedicated 24 VDC supply for the open-collector circuit.

The FORM C relays and the open-collector output can be programmed to indicate any of the following: NO FUNCTION, RUN, FAULT, FAULT LOACKOUT, AT SPEED, ABOVE SET SPEED, CURRENT LIMIT, FOLLOWER PRESENT, MAINTENANCE TARGET, AUTO SPEED MODE, or START PENDING. See Parameters: 121 - RELAY #1 FUNCTION, 122 - RELAY #2 FUNCTION, and 124 - TB-14 FUNCTION. Refer to Section 6.2.5 for a complete description of each of these status indications.

14.2.9 EMERGENCY STOP (E-STOP)

Terminal TB-22 is the E-STOP input, which must be closed to TB-2 for the drive to operate. If the connection between TB-22 and TB-2 is opened, the drive will trip into an EMERGENCY STOP fault. If the drive is running when this occurs, the drive will COAST to a stop, even if Parameter 65 - COAST TO STOP is disabled.

The QC Series drive is shipped from the factory with a jumper between TB-22 and TB-2. If safety interlocks are to be connected to the drive, remove the factory jumper and install the interlocks between TB-22 and TB-2.

WARNING!

Do not connect 120 Vac to the control board! Severe damage will result! Use relays to provide dry contacts to the terminal strip. Only RELAY 1 and RELAY 2 are rated for 120 Vac.

15.0 QC SERIES CONTROL WIRING DIAGRAMS

15.1 QC SERIES TERMINAL STRIP

Shown below is the terminal strip on the main control board, along with a brief description of the function of each terminal.

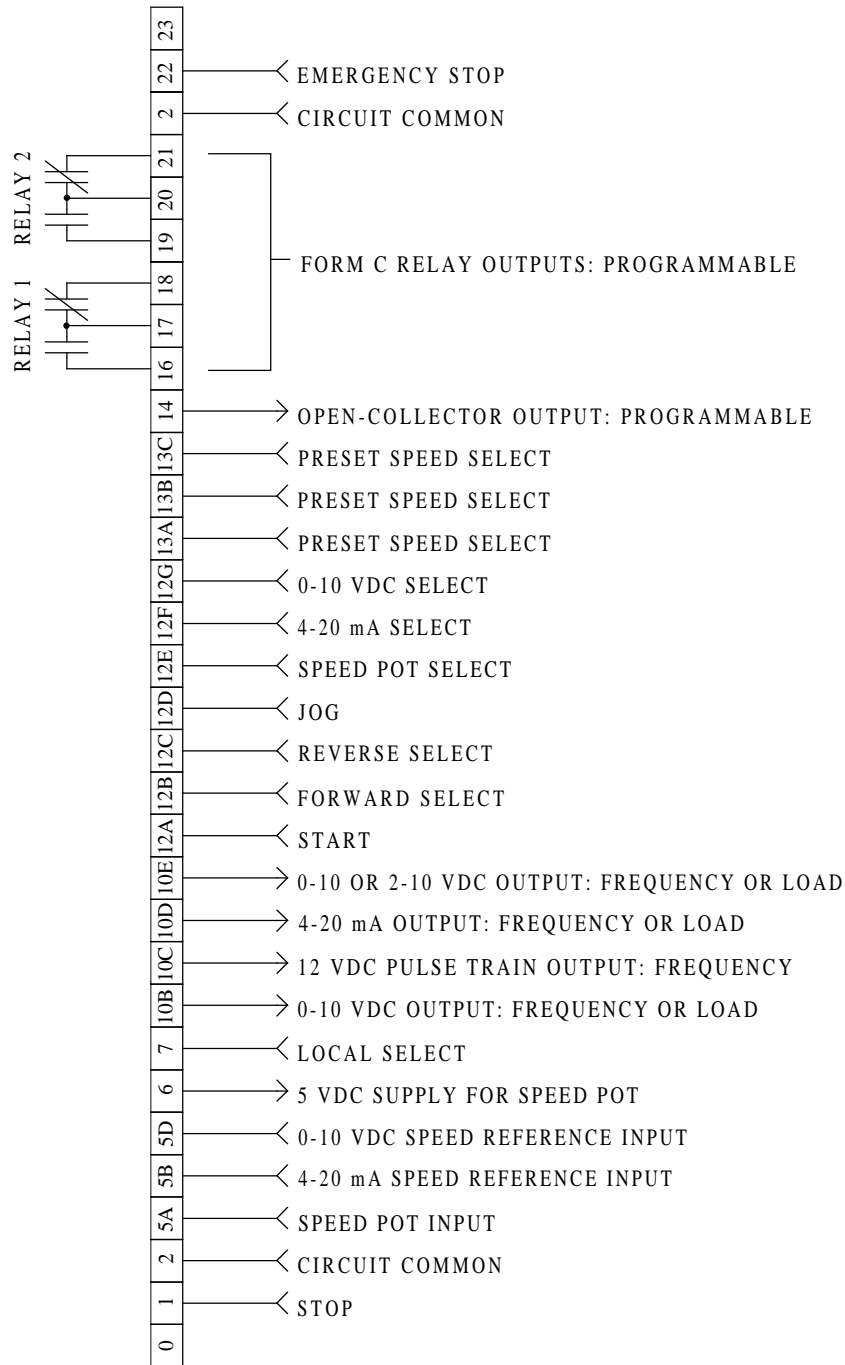

A complete description of operating the drive in the REMOTE mode can be found in Section 14.2. The following diagrams provide a quick reference for wiring the drive for the most common configurations.

15.2 TWO-WIRE START/STOP CONTROL

Shown below is the wiring diagram for a typical two-wire start/stop control scheme, using one maintained contact (such as that from a PLC) for START and STOP commands. Included is the wiring for a 4-20 mA speed reference input.

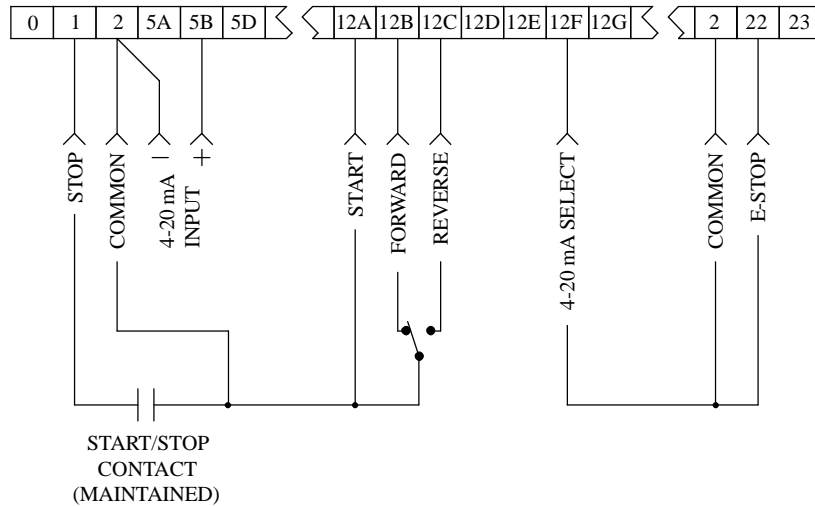

NOTES:

1. Remove the factory jumper between TB-7 and TB-2 to select REMOTE mode.
2. Close TB-1 to TB-2 to START, and open to STOP.
3. If REVERSE direction is required, Parameter 66 - FWD/REV must be set to FWD + REV. If REVERSE direction is not required, TB-12B (FORWARD) must be wired directly to TB-2.
4. TB-12F (4-20 mA SELECT) must be closed to TB-2 in order for the drive to respond to the 4-20 mA signal. If TB-12F is not closed to TB-2, speed control will default to the keypad.
5. To connect normally closed safety interlocks, remove the factory E-STOP jumper and wire the interlocks between TB-22 and TB-2.

WARNING!

Do not connect 120 Vac to the control board! Severe damage will result! Use relays to provide dry contacts to the terminal strip. Only RELAY 1 and RELAY 2 are rated for 120 Vac.

15.3 ALTERNATE START/STOP CONTROL

Shown below is the wiring diagram for the alternate start/stop control scheme described in Section 14.2.3. This method uses the direction selection contacts (TB-12B and TB-12C) to START and STOP the drive.

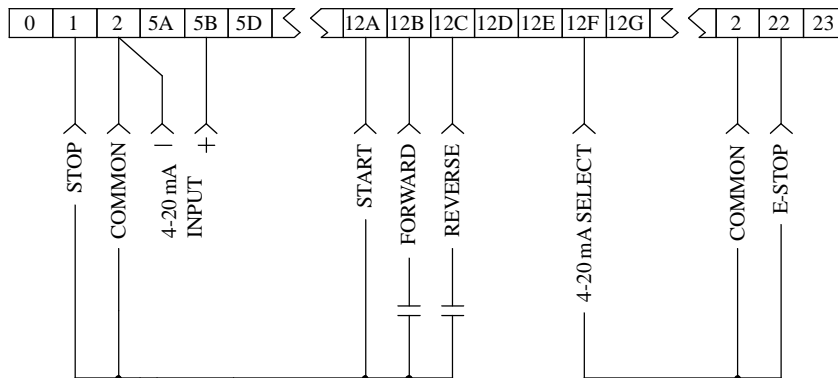

NOTES:

1. Remove the factory jumper between TB-7 and TB-2 to select REMOTE mode.
2. ENABLE either Parameter 70 - AUTO START, or 71 - RESTART ON FAULT. This will put the drive in RUN mode upon application of power. However, there will be no output to the motor until a direction is selected at TB-12B or TB-12C.
3. To START in the FORWARD direction, close TB-12B to TB-2. Open TB-12B to STOP. To START in the REVERSE direction, close TB-12C to TB-2. Open TB-12C to STOP. If REVERSE direction is required, Parameter 66 - FWD/REV must be set to FWD + REV.
4. TB-12F (4-20 mA SELECT) must be closed to TB-2 in order for the drive to respond to the 4-20 mA signal. If TB-12F is not closed to TB-2, speed control will default to the keypad.
5. To connect normally closed safety interlocks, remove the factory E-STOP jumper and wire the interlocks between TB-22 and TB-2.

WARNING!

Do not connect 120 Vac to the control board! Severe damage will result! Use relays to provide dry contacts to the terminal strip. Only RELAY 1 and RELAY 2 are rated for 120 Vac.

15.4 THREE-WIRE START/STOP CONTROL

A typical three-wire start/stop control scheme is shown below which uses two momentary contacts to START and STOP the drive. The START contact is normally open, and the STOP contact is normally closed. Also shown is the wiring for a 0-10 VDC speed reference input.

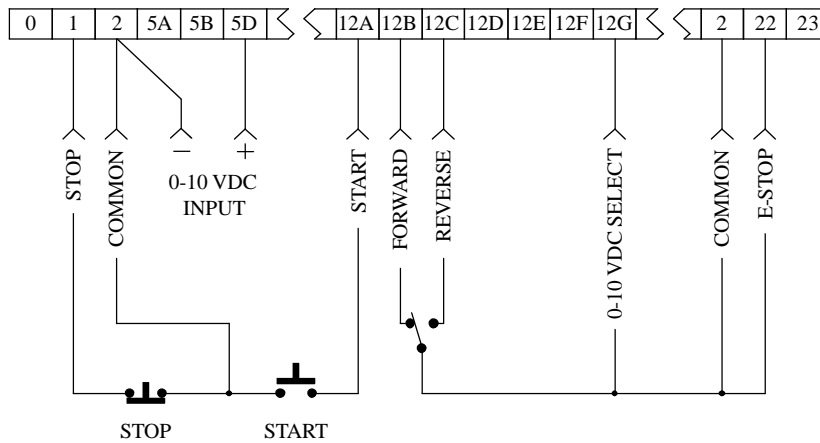

NOTES:

1. Remove the factory jumper between TB-7 and TB-2 to select REMOTE mode.
2. If REVERSE direction is required, Parameter 66 - FWD/REV must be set to FWD + REV. If REVERSE direction is not required, TB-12B (FORWARD) must be wired directly to TB-2.
3. TB-12G (0-10 VDC SELECT) must be closed to TB-2 in order for the drive to respond to the 0-10 VDC signal. If TB-12G is not closed to TB-2, speed control will default to the keypad.
4. To connect normally closed safety interlocks, remove the factory E-STOP jumper and wire the interlocks between TB-22 and TB-2.

WARNING!

Do not connect 120 Vac to the control board! Severe damage will result! Use relays to provide dry contacts to the terminal strip. Only RELAY 1 and RELAY 2 are rated for 120 Vac.

15.5 SPEED POT AND PRESET SPEED CONTROL

The following diagram shows typical wiring for speed control via speed pot and/or preset speeds. Also shown is the wiring for either a two-wire (maintained contact) or a three-wire (momentary contacts) start/stop circuit.

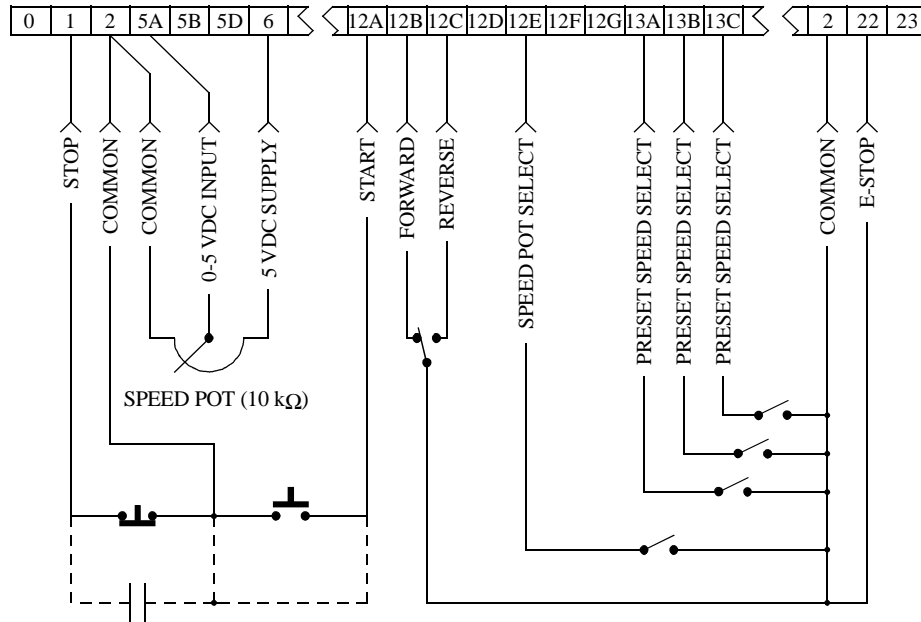

NOTES:

1. Remove the factory jumper between TB-7 and TB-2 to select REMOTE mode.
2. Close TB-12E to TB-2 to select speed control from the speed pot.
3. Use TB-13A, TB-13B, and TB-13C to activate the preset speeds. Refer to Parameters 11-17.
4. To connect normally closed safety interlocks, remove the factory E-STOP jumper and wire the interlocks between TB-22 and TB-2.

WARNING!

Do not connect 120 Vac to the control board! Severe damage will result! Use relays to provide dry contacts to the terminal strip. Only RELAY 1 and RELAY 2 are rated for 120 Vac.

16.0 PROGRAMMING THE QC SERIES DRIVE

The drive is programmed using the keypad to change parameter values to suit a particular application. The keypad is also used to operate the drive when in the LOCAL mode (TB-7 closed to TB-2). An LED to the right of the LCD display indicates when the drive is in a RUN state. The keypad is shown below, along with the display that should appear when it is first powered up:

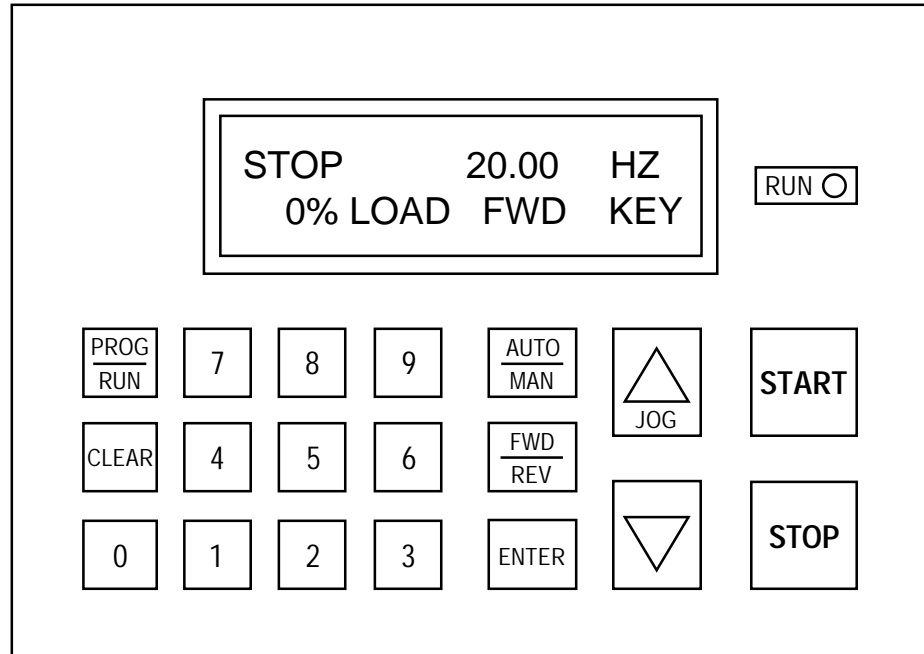

To program the drive, the PROGRAM mode must be entered by pressing the PROG/RUN button on the keypad. If the password protection is disabled, pressing the PROG/RUN key will result in direct entry into the PROGRAM mode. If the password protection is enabled, the PASSWORD prompt will appear when an attempt is made to enter the PROGRAM mode. The PASSWORD display appears as follows:

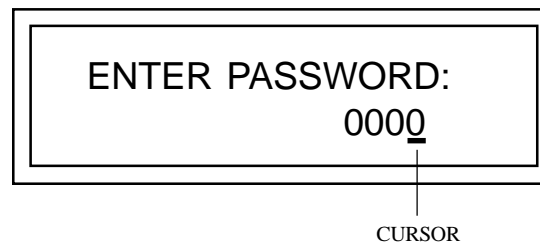

To enter the password, use the numeric keys to type in the password value and then press the ENTER key. If the ENTER key is pressed while the PASSWORD prompt reads 0000, the FAULT HISTORY (Parameter 200) display will be accessed, allowing an operator to view the FAULT HISTORY without knowing the password.

NOTE: The factory default password is 0019.

Once the correct password is entered, the PROGRAM mode will be accessed and the first parameter will be displayed, which is Parameter 1 - CURRENT LIMIT. This is shown below:

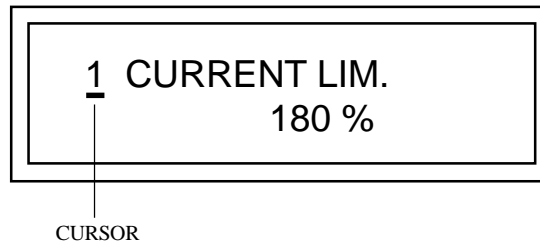

Parameters can be located either by scrolling with the UP and DOWN arrow keys, or by direct entry using the numeric keys. When using the arrow keys, scroll to the desired parameter and press the ENTER key to shift the cursor from the parameter number to the parameter value. When using the numeric keys, type in the parameter number and press the ENTER key. This will call up the desired parameter and automatically shift the cursor to the parameter value. The display below shows the cursor highlighting the parameter value:

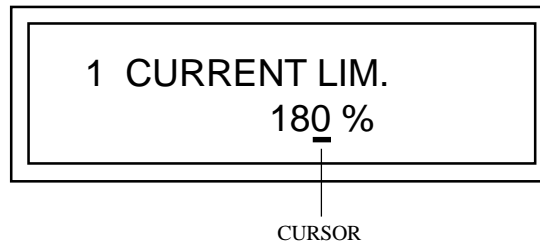

Once the cursor is highlighting the parameter value, it can be changed to a new value. If the parameter has a numerical value, it can be changed using the arrow keys or the numeric keys. If the parameter has specific choices that can be selected, use the arrow keys to scroll through the list of possible choices. Once the desired value or option is selected, press the ENTER key to store the new setting. If the new setting is not ENTERED, it will not take effect and the old setting will still be valid.

To exit the PROGRAM mode, press the PROG/RUN key. If the PROGRAM mode is entered again within three minutes, an asterisk will appear in the PASSWORD prompt which indicates that the password does not need to be entered to access the PROGRAM mode. Simply press the ENTER key, and the last parameter that was viewed or changed will come up on the display. After three minutes has passed (or the asterisk is no longer present in the PASSWORD prompt), the password will have to be entered again when attempting to access the PROGRAM mode.

NOTE: To disable the password protection, refer to Parameter 148 - PASSWORDS in Section 18.0 - DESCRIPTION OF PARAMETERS.

17.0 PARAMETER MENU

PARAMETER MENU				
PARAM. NUMBER	PARAMETER NAME	RANGE OF ADJUSTMENT	FACTORY DEFAULT	PASSWORD LEVEL
1	CURRENT LIM.	5 - 180 % (QC1000/2000) 5 - 120 % (QC3000)	180 % (QC1000/2000) 120 % (QC3000)	1
2	TH. OVERLOAD	50 - 150 % (QC1000/2000) 50 - 120 % (QC3000)	150 % (QC1000/2000) 120 % (QC3000)	1
3	SLIP COMP	0.0 - 5.0 %	0	1
4	SPEED 4MA/0V	0.00 - 360.00 Hz (NOTE 1)	0.00 Hz	1
5	SPD 20MA/10V	0.00 - 360.00 Hz (NOTE 1)	60.00 Hz	1
9	PRE. ACC/DEC	DISABLED, ENABLED	DISABLED	1
11 - 17	PRE #1 - #7 SPEED	MIN FREQ - MAX FREQ	10.00 Hz	1
19	JOG SPEED	MIN FREQ - MAX FREQ	10.00 Hz	1
20	NORMAL ACCEL	(NOTE 2)	30.0 SEC	1
21 - 27	PRE #1 - #7 ACCEL	(NOTE 2)	30.0 SEC	1
29	JOG ACCEL	(NOTE 2)	30.0 SEC	1
30	NORMAL DECEL	(NOTE 2)	30.0 SEC	1
31 - 37	PRE #1 - #7 DECEL	(NOTE 2)	30.0 SEC	1
38	TAPER DECEL	DISABLED, ENABLED	DISABLED	1
39	JOG DECEL	(NOTE 2)	30.0 SEC	1
41 - 43	SKIP SPEED #1 - #3	0.00 Hz - MAX FREQ	0.00 Hz	2
44	SKIP BAND.	0.00 - 10.00 Hz	2.00 Hz	2
50	TB10B/D FUNC	0-10 V FREQ, 0-10 V LOAD, 4-20 MA FREQ, 4-20 MA LOAD	0-10 V FREQ	2
51	FREQ OUT MAX	1.00 - 360.00 Hz (NOTE 1)	60.00 Hz	2
52	TB10D R. OHM	0 - 250	250	2
53	TB10E FUNC.	DISABLED, 0-10 V FREQ, 0-10 V LOAD, 2-10 V FREQ, 2-10 V LOAD	0 - 10 V LOAD	2
54	LOAD OUT MAX	10 - 200 %	125 %	2
61	MINIMUM FREQ	0.00 - 120 Hz (NOTE 1)	0.50 Hz	2
62	MAXIMUM FREQ	0.00 - 120 Hz (NOTE 1)	60.00 Hz	2
64	STABILITY	NORM, LOW, MED, HIGH	NORM	2
65	COAST STOP	DISABLED, ENABLED	DISABLED	2
66	FWD / REV	FWD ONLY, REV ONLY, FWD + REV	FWD ONLY	2

NOTE 1: MAXIMUM SETTING IS 650 Hz FOR DRIVES WITH HIGH OUTPUT FREQUENCY OPTION.

NOTE 2: REFER TO SECTION 18.0 - DESCRIPTION OF PARAMETERS.

PARAMETER MENU (CONT'D)				
PARAM. NUMBER	PARAMETER NAME	RANGE OF ADJUSTMENT	FACTORY DEFAULT	PASSWORD LEVEL
67	AUTO / MAN SEL	AUTO SPEED, MANUAL SPEED, AUTO & MAN LOCAL, AUTO & MAN SPEED	AUTO & MAN LOCAL	2
70	AUTO START	DISABLED, ENABLED	DISABLED	2
71	RESTRT / FAULT	DISABLED, ENABLED	DISABLED	2
72	RESTRT LIMIT	1 - 5	3	2
73	RESTRT DELAY	1.0 - 180.0 SEC	5.0 SEC	2
75	RESTRT DECEL	0.1 - 999.9 SEC	10.0 SEC	2
76	RESTRT C LIM	10 - 180 %	100%	2
80	DC BRAKE	DISABLED, CONTINUOUS, ON START, ON STOP, @ ZERO SPEED, START & STOP, ZERO SPEED & STOP	DISABLED	2
82	DC BRK LOAD	20 - 180 %	30%	2
83	STOP BRAKE	0.1 - 60.0 SEC	5.0 SEC	2
84	START BRAKE	0.1 - 20.0 SEC	5.0 SEC	2
86	DYNAM. BRAKE	DISABLED, ENABLED	DISABLED	2
90	SPEED UNITS	HZ, RPM, % RPM, /S, /M, /H, #/S, #/M, #/H	HZ	2
91	SPEED MULT.	0.10 - 400.00	30	2
92	LOAD UNITS	% LOAD, AMPS	% LOAD	2
93	LOAD MULT.	0.01 - 300.00	1	2
94	AC INPUT	240 / 480 / 590, 200 / 400 / 480	240 / 480 / 590	2
95	SPEED DP	XXXXX, XXXX.X, XXX.XX, XX.XXX, X.XXXX, .XXXXX	XXXXX	2
100	BASE FREQUENCY	10.00 - 360.00 Hz (NOTE 1)	60.00 Hz	2
101	V/HZ CURVE	LINEAR - 1.0, VAR TORQUE - 1.3, VAR TORQUE - 1.6, VAR TORQUE - 2.0	LINEAR - 1.0 (QC1000/2000) VAR TORQUE - 1.6 (QC3000)	2
104	AUTO V BOOST	0.0 - 20.0 %	0.0 %	2
105	MANUAL BOOST	0.0 - 30.0 %	(NOTE 2)	2

NOTE 1: MAXIMUM SETTING IS 650 Hz FOR DRIVES WITH HIGH OUTPUT FREQUENCY OPTION.

NOTE 2: REFER TO SECTION 18.0 - DESCRIPTION OF PARAMETERS.

PARAMETER MENU (CONT'D)				
PARAM. NUMBER	PARAMETER NAME	RANGE OF ADJUSTMENT	FACTORY DEFAULT	PASSWORD LEVEL
121	RELAY #1	NO FUNCTION, RUN,	RUN (RELAY #1)	2
122	RELAY #2	FAULT, FAULT LOCKOUT,	FAULT (RELAY #2)	2
124	TB-14 FUNCT	AT SPEED, ABOVE SET SPD, CURRENT LIMIT, FOLLOWER PRESENT, MAINT. TARGET, AUTO SPEED MODE, START PENDING	NO FUNCTION (TB-14)	2
123	REL. SET SPD	0.00 - 120.00 Hz (NOTE 1)	0.50 Hz	2
130	DRIVE POWER	0.0 - 250.0 HP	0.0 HP	2
132	MAINT TARGET	0 - 65000 HR	0 HR	2
133	DISPLAY FUNC	NORMAL, ACTUAL SPEED	NORMAL	2
137	CARRIER SEL	1.5, 8, 10, 12 kHz	1.5 kHz	2
141	FACT PARAMS	DISABLED, ENABLED	DISABLED	2
142	CLR HISTORY	DISABLED, ENABLED	DISABLED	2
144	SW VERSION	(VIEW - ONLY)	(N/A)	2
145	SERIAL COMMS	DISABLED, DETECT, MONITOR ONLY, PROGRAM, CONTROL, PROG. & CONTROL	PROGRAM	2
146	SER. TIMEOUT	0 - 30 SEC	8 SEC	2
147	SER. ADDRESS	1 - 247 (Modbus) 1 - 255 (Metasys)	1	2
148	PASSWORDS	DISABLED, ENABLED	ENABLED	2
149	LEVEL #1	0000 - 9999	9100	2
150	LEVEL #2	0000 - 9999	0019	2
198	LANGUAGE	ENGLISH, SPANISH	ENGLISH	2
200	FAULT HISTORY	(VIEW - ONLY)	(N/A)	2

NOTE 1: MAXIMUM SETTING IS 1300 Hz FOR DRIVES WITH HIGH OUTPUT FREQUENCY OPTION.

18.0 DESCRIPTION OF PARAMETERS

1 CURRENT LIM. (CURRENT LIMIT)

The current limit setting determines the maximum value of the output current. This is usually done to limit motor torque capability. For most applications the current limit is maintained at the maximum setting. When the drive output current exceeds the CURRENT LIMIT value, the drive will attempt to avoid an OVERLOAD fault by decelerating the load in an effort to reduce the output current. When the overcurrent condition passes, the drive will return to normal operation and accelerate back to the speed setpoint. However, if the drive cannot reduce the current quickly enough by decelerating, it will trip on an OVERLOAD fault. Also, if the drive enters current limit during acceleration, the time required to reach the speed setpoint will be longer than the time indicated by the acceleration rate setting (NORMAL ACCEL, PRESET ACCEL, or JOG ACCEL).

2 TH. OVERLOAD (THERMAL OVERLOAD)

The THERMAL OVERLOAD setting is used to protect the motor from overheating due to excess current. The trip time for the THERMAL OVERLOAD setting is based on an "inverse I^2t " function. This function emulates a mechanical thermal overload relay (commonly referred to as "heaters").

To determine the correct THERMAL OVERLOAD setting, divide the full load current rating of the motor by the output current rating of the drive, and multiply by 150% (for QC1000/2000), or 120% (QC3000). Entering the resulting percentage into this parameter will calibrate the overload circuitry to the particular motor, allowing the motor to draw either 150% or 120 % of the *motor* current rating (rather than the *drive* rating) for one minute.

Example: A 10 HP, 480 Vac QC Series drive with an output current rating of 14 amps is operating a 7.5 HP motor with a full load current rating of 11 amps. Divide the motor current rating by the drive output current rating and then multiply by 150%: $(11.0 / 14.0) \times 150\% = 118\%$. Entering this value into the THERMAL OVERLOAD parameter will allow the motor to operate at 16.5 amps (150% of 11 amps) for one minute. If the THERMAL OVERLOAD parameter is left at 150%, the motor would be allowed to operate at 21 amps (150% of 14 amps) for one minute.

3 SLIP COMP (SLIP COMPENSATION)

SLIP COMPENSATION is used to compensate for changes in motor speed ("slip") caused by changes in load. In a standard AC induction motor, as the load on the motor increases, the motor current increases and the motor shaft speed decreases. By increasing the output frequency in response to the increased motor current, motor speed fluctuation can be greatly reduced. Speed regulation with no load to full load fluctuations of less than 1% of base speed are attainable in most applications. SLIP COMPENSATION is often set to 3% as that is the standard slip rating of most AC induction motors.

4 SPEED 4MA/0V (SPEED AT 4 mA OR 0 VDC)

This parameter selects the output frequency of the drive that will correspond to the minimum analog speed reference input (4 mA or 0 VDC). This parameter is used in conjunction with Parameter 5 below to define a speed range for the drive that corresponds to the analog speed reference input (4 - 20 mA or 0 - 10 VDC).

5 **SPD 20MA/10V**

(SPEED AT 20 mA OR 10 VDC)

This parameter selects the output frequency of the drive that will correspond to the maximum analog speed reference input (20 mA or 10 VDC). This parameter is used in conjunction with Parameter 4 above to define a speed range that corresponds to the analog speed reference input (4 - 20 mA or 0 - 10 VDC).

NOTE: The drive can be programmed for inverse operation so that minimum speed reference corresponds to the maximum output frequency, and the maximum speed reference corresponds to the minimum output frequency. This is accomplished by setting SPEED 4MA/0V larger than SPD 20MA/10V. Therefore, as the speed reference increases, the drive speed will decrease, and as the speed reference decreases, the drive speed will increase. See the example below.

Example: The drive is being controlled by a pressure transducer that provides a 4-20 mA signal proportional to duct pressure. The minimum frequency desired is 20 Hz, and the maximum is 60 Hz. Set SPEED 4MA/0V for 60 Hz, and SPD 20MA/10V for 20 Hz. As the duct pressure rises, the output signal from the transducer will increase, causing the speed of the drive to decrease. This results in a decrease in duct pressure and a decreasing transducer signal. The drive responds to the decreasing signal by increasing speed, which again raises the duct pressure. In this way, the average duct pressure can be maintained at a desired level. If the acceleration and deceleration rates are set too fast however, the drive will react quickly to signal changes which will cause the drive speed to hunt up and down excessively.

9 **PRE. ACC/DEC**

(PRESET SPEED ACCEL & DECEL)

This parameter is used to ENABLE or DISABLE the individual acceleration and deceleration times (Parameters 21-27, and 31-37) for each of the seven preset speeds. When disabled, the preset speeds will follow the NORMAL ACCEL (Parameter 20) and NORMAL DECEL (Parameter 30) settings.

11-17 **PRE #1 SPEED - PRE #7 SPEED**

(PRESET SPEEDS)

Preset speeds are programmable and are activated via contact closures between TB-2 and TB-13A, 13B, and 13C. Seven preset speeds are available, which can be activated according to the following table:

PRESET SPEED ACTIVATION			
SPEED #	TB-13A to TB-2	TB-13B to TB-2	TB-13C to TB-2
1	CLOSED	OPEN	OPEN
2	OPEN	CLOSED	OPEN
3	OPEN	OPEN	CLOSED
4	CLOSED	CLOSED	OPEN
5	CLOSED	OPEN	CLOSED
6	OPEN	CLOSED	CLOSED
7	CLOSED	CLOSED	CLOSED

19 **JOG SPEED**

The JOG SPEED sets the operating speed of the drive in the JOG mode. JOG can be initiated from the keypad (local) or the terminal strip (remote). Refer to Section 13.0 - KEYPAD CONTROL, and 14.0 - CONTROL WIRING.

20 **NORMAL ACCEL**

(NORMAL ACCELERATION)

This parameter sets the acceleration time when the speed is controlled from the keypad, a speed pot, 4-20 mA, or 0-10 VDC. It also determines the acceleration rate for the preset speeds if Parameter 9 - PRESET ACC/DEC is DISABLED. The NORMAL ACCEL setting indicates the time to accelerate from 0 Hz to BASE FREQUENCY (Parameter 100). The minimum acceleration setting depends on the horsepower rating of the drive. See the table below for the NORMAL ACCEL range of adjustment.

NOTE: The ability to accelerate a given load at a particular rate will be limited by the output power capabilities of the drive/motor combination. The acceleration of high-inertia and high-friction loads may be affected by the current limiting characteristics of the drive. See Parameters: 1 - CURRENT LIMIT, 104 - AUTO V BOOST, and 105 - MANUAL BOOST.

ACCELERATION LIMITS	
HP	RANGE OF ADJUSTMENT
1 - 15	0.1 - 3600.0 SEC
20 - 250	1.0 - 3600.0 SEC

21-27 **PRE #1 ACCEL - PRE #7 ACCEL**

(PRESET SPEED ACCELERATION)

These parameters set the individual acceleration times that correspond to the PRESET SPEEDS (Parameters 1-7). These settings are only active if Parameter 9 - PRESET ACC/DEC is ENABLED. The range of adjustment is the same as that for NORMAL ACCEL.

29 **JOG ACCEL**

(JOG ACCELERATION)

This parameter sets the acceleration time for the Jog speed. The range of adjustment is the same as that for NORMAL ACCEL.

30 **NORMAL DECEL**

(NORMAL DECELERATION)

This parameter sets the deceleration time when the speed is controlled by the keypad, a speed pot, 4-20 mA, or 0-10 VDC. It also determines the deceleration rate if Parameter 9 - PRESET ACC/DEC is DISABLED. The NORMAL DECEL setting indicates the time to decelerate from BASE FREQUENCY (Parameter 100) to 0 Hz. The minimum deceleration time depends on horsepower, and whether Dynamic Braking (DB) is being used. See the table below for the NORMAL DECEL range of adjustment.

DECELERATION LIMITS		
HP	DECEL RANGE (NOTE 1)	
	WITHOUT DB	WITH DB
1 - 7.5	0.1 - 3600.0 SEC	0.1 - 3600.0 SEC
10 - 15	0.3 - 3600.0 SEC	0.1 - 3600.0 SEC
20 - 40	1.0 - 3600.0 SEC	0.3 - 3600.0 SEC
50 - 75	3.0 - 3600.0 SEC	0.8 - 3600.0 SEC
100 - 250	7.0 - 3600.0 SEC	1.8 - 3600.0 SEC

NOTE 1: The parameter can actually be set as low as the value shown in the WITH DB column. However, the value shown in the WITHOUT DB column is the operational limit of a drive without dynamic braking. For example, NORMAL DECEL can be set as low as 0.8 seconds on a 50 HP drive without dynamic braking, but the actual minimum deceleration time would be 3.0 seconds.

NOTE 2: If a high-inertia load is decelerated too quickly, the motor will regenerate voltage back into the drive on the DC bus. This can result in a HI BUS VOLTS fault. This can normally be corrected by extending the deceleration time. However, in applications that require quick deceleration of high-inertia loads, dynamic braking may be required. Refer to Section 19.0 - OPTIONS.

31-37 **PRE #1 DECEL - PRE #7 DECEL** (PRESET SPEED DECELERATION)

These parameters set the individual deceleration times that correspond to the PRESET SPEEDS (Parameters 1-7). These settings are only active if Parameter 9 - PRESET ACC/DEC is ENABLED. The range of adjustment is the same as that for NORMAL DECEL.

38 **TAPER DECEL**

Taper decel varies the deceleration "ramp" in order to increase stopping capacity on high inertia loads. When this parameter is ENABLED, the deceleration curve is altered from a linear function to the "top half of an S-curve". During the first part of the deceleration period, when rotational kinetic energy is the highest, the deceleration rate is slow. During the later part of the deceleration period the deceleration rate increases, and becomes a linear function once again.

NOTE: This parameter only appears on 590/480 Vac models 20 HP and below, and on 240/200 and 480/400 Vac models 40 HP and below. All other models have this feature built in to the deceleration function in order to help avoid HI BUS VOLTS faults when decelerating high-inertia loads.

39 **JOG DECEL** (JOG DECELERATION)

This parameter sets the deceleration time for the Jog speed. The range of adjustment is the same as that for NORMAL DECEL.

41-43 **SKIP SPEED #1 - SKIP SPEED #3** (SKIP FREQUENCIES)
44 **SKIP BAND.** (SKIP BANDWIDTH)

These parameters are used to prevent continuous operation at critical speeds, or frequencies. Critical frequencies cause mechanical resonance, resulting in excessive vibration of the driven equipment. The SKIP SPEEDS are used with the SKIP BANDWIDTH to define up to three speed avoidance ranges. The SKIP SPEED setting is the mid-point of the speed avoidance range, while the SKIP BANDWIDTH defines the width of the range.

Example: The critical frequency is 20 Hz, and a 5 Hz bandwidth is desired. Set SKIP SPEED #1 to 20 Hz, and set SKIP BANDWIDTH to 5 Hz. This will result in a speed avoidance range from 17.5 Hz to 22.5 Hz. If the drive were operating below 17.5 Hz, and then commanded to operate at a speed within the avoidance range, the drive would accelerate to 17.5 Hz and remain there until the speed setpoint becomes greater than 22.5 Hz. The drive would then accelerate through the avoidance range to the new setpoint. Likewise, if the drive were operating above 22.5 Hz, and then commanded to operate at a speed within the avoidance range, the drive would decelerate to 22.5 Hz and remain there until the speed setpoint becomes less than 17.5 Hz. The drive would then decelerate through the avoidance range to the new setpoint.

DC injection braking provides shaft stopping (holding) torque by supplying low level DC voltage to the motor's stator coils. DC braking can provide up to the motor's full rated torque (for short periods of time).

WARNING!
EXCESSIVE DC BRAKING MAY CAUSE SEVERE MOTOR HEATING! BE SURE TO MAINTAIN MOTOR TEMPERATURE WITHIN RATED LIMITS.

This parameter can be set for one of the following:

DISABLED	DC braking is not functional.
CONTINUOUS	DC braking is energized until the drive is given a START command. If COAST TO STOP (Parameter 65) is ENABLED, DC braking will energize a when the drive is given a STOP command. If COAST TO STOP is DISABLED, DC braking will energize when the output frequency reaches 0 Hz.
ON START	DC braking energizes when a START command is given, and remains energized until the START BRAKE (Parameter 84) time has elapsed. Once the time elapses, the drive will START. During the START BRAKE period, the screen will display START in the DRIVE STATUS portion of the display.
ON STOP	DC braking energizes after a STOP for the time period determined by STOP BRAKE (Parameter 83). If COAST TO STOP (Parameter 65) is ENABLED, DC braking will energize when the drive is given a STOP command. If COAST TO STOP is DISABLED, DC braking will energize when the output frequency reaches 0 Hz. If the drive is given a START command during the STOP BRAKE period, it will start.
@ ZERO SPEED	DC braking energizes when the drive reaches zero speed (0.1 Hz or less) and will remain energized for the STOP BRAKE (Parameter 83) time period. If the speed setpoint rises above 0.5 Hz during the STOP BRAKE period, the brake will de-energize and the drive will START.
	NOTE: This braking mode requires that Parameter 61 - MINIMUM FREQ be set to 0 Hz.
START & STOP	DC braking energizes when a START or STOP command is given as described above for ON START and ON STOP modes.
ZERO SPEED & STOP	DC braking energizes when the drive reaches zero speed (0.1 Hz or less) as described above for @ ZERO SPEED mode, or when given a STOP command as described above for ON STOP mode.

This parameter sets the magnitude of the current applied to the motor by the DC braking circuit. This parameter is based on the drive's nameplate current rating. DC BRAKE LOAD should be set to the lowest possible value which gives satisfactory operation in order to minimize motor heating.

94 **AC INPUT**

(INPUT VOLTAGE SELECTION)

The QC Series drives are dual rated (200/240 Vac, 400/480 Vac, and 480/590 Vac) to allow operation on a wide range of input voltages. QC1000/2000 Series drives also have dual current ratings to compensate for lower input voltage, and this parameter must be set correctly to calibrate the thermal overload circuitry. The selections are described below:

- | | |
|-----------------|----------------------------------------------------------------------------------------------------------------------------------------------------------|
| 240 / 480 / 590 | Use this selection for supply voltages of 230/240 Vac (on 200/240 Vac units), 460/480 Vac (on 400/480 Vac units), or 575/600 Vac (on 480/590 Vac units). |
| 200 / 400 / 480 | Use this selection for supply voltages of 200/208 Vac (on 200/240 Vac units), 380/415 Vac (on 400/480 Vac units), or 480 Vac (on 480/590 Vac units). |

For QC3000 Series drives, set this parameter to 240/480/590, regardless of the input voltage. The QC3000 does not have a dual current rating, and if this parameter is set to 200/400/480, the thermal overload circuitry will not be properly calibrated and will trip prematurely. QC3000 Series drives still require that the voltage plug on the power board be installed in the correct position (see NOTE below).

NOTE: In addition to setting this parameter correctly, a voltage plug on the power board must be installed in the correct position. See Section 9.0 - VOLTAGE SELECTION.

95 **SPEED DP**

(SPEED DECIMAL POINT)

This parameter is used to move the decimal point location in the speed indication display. This parameter is only active if SPEED UNITS (Parameter 90) is set to one of the following: /S, /M, /H, #/S, #/M, and #/H. This parameter will have no effect if SPEED UNITS is set to HZ, RPM, or %RPM.

100 **BASE FREQUENCY**

The BASE FREQUENCY is the frequency at which the drive applies full output voltage to the motor. For most applications the base frequency should be set to the rated frequency of the motor.

The BASE FREQUENCY determines the V/Hz ratio of the drive output. For example, if the drive is rated for 460 Vac and the BASE FREQUENCY is set to 60 Hz, the drive will maintain a constant ratio of 7.66 V/Hz from 0 to 60 Hz. However, if Parameter 101 - V/HZ CURVE is not set for LINEAR 1.0, the V/Hz ratio will not be constant. The BOOST parameters (Parameters 104 and 105) also alter the V/Hz ratio.

101 **V/HZ CURVE**

(VOLTS PER HERTZ CURVE)

This parameter is used to change the relationship between the output voltage and frequency. Choices are: LINEAR - 1.0, VAR TORQUE - 1.3, VAR TORQUE - 1.6, and VAR TORQUE - 2.0.

LINEAR-1.0 gives a linear relationship between voltage and frequency, resulting in a constant V/Hz ratio, which yields constant motor torque capability. The three VARIABLE TORQUE values (1.3, 1.6, and 2.0) are used to gain optimum energy savings and reduce acoustical noise in variable torque applications such as pumps and fans. An infinite array of V/Hz patterns are available by adjusting the BASE FREQUENCY (Parameter 100) and V/HZ CURVE.

104 **AUTO V BOOST**

(ACCELERATION BOOST)

AUTO V BOOST overrides the V/Hz setting determined by the BASE FREQUENCY and V/HZ CURVE to increase output voltage during acceleration, which increases motor torque. AUTO V BOOST is usually used in applications with high inertia loads where quick accelerations are desired. Setting AUTO V BOOST too high may cause erratic drive behavior. Therefore, it should be set to the lowest value that yields satisfactory performance.

105 **MANUAL BOOST**

(STARTING BOOST)

The MANUAL BOOST overrides the V/Hz setting determined by the BASE FREQUENCY and V/HZ CURVE to increase output voltage at lower frequencies, which increases motor torque. MANUAL BOOST is used in applications which require high starting torque. (e.g. conveyors, lifts, and other loads which have high static friction or high inertia). As with AUTO V BOOST (Parameter 104), MANUAL BOOST should be set to the lowest value that yields satisfactory performance, to avoid erratic drive behavior. The default MANUAL BOOST setting depends on horsepower. See the table below for the default settings.

NOTE: Both AUTO V BOOST and MANUAL BOOST will reset to factory default settings if Parameter 137 - CARRIER SEL is changed. Therefore, if these parameters are used, they must be re-programmed after the carrier frequency is changed. Also, the amount of boost required to achieve the same performance may be different after the carrier frequency is changed.

MANUAL BOOST FACTORY DEFAULT SETTINGS					
HP	DEFAULT	HP	DEFAULT	HP	DEFAULT
1	5.3%	15	2.7%	60	2.1%
2	4.4%	20	2.6%	75	2.0%
3	4.0%	25	2.5%	100	1.9%
5	3.5%	30	2.4%	125	1.9%
7.5	3.2%	40	2.3%	150	1.8%
10	3.0%	50	2.2%	200 - 250	1.8%

121 **RELAY #1**

(PROGRAMMABLE OUTPUT RELAY)

The control board has two auxiliary relays which can be programmed for a variety of functions: NO FUNCTION, RUN, FAULT, FAULT LOCKOUT, AT SPEED, ABOVE SET SPEED, CURRENT LIMIT, FOLLOWER PRESENT, MAINTENANCE TARGET, AUTO SPEED MODE, and START PENDING. Refer to Section 6.2.5 - QC STATUS OUTPUT RELAYS for a complete description of the output relay indications.

This parameter sets the output indication of RELAY #1. The default setting is RUN.

Each relay has a set of FORM C contacts rated 2 amps at 28 VDC or 120 VAC. Control wiring diagrams show relays in the rest state (coils NOT energized).

122 **RELAY #2**

(PROGRAMMABLE OUTPUT RELAY)

This parameter sets the output indication of RELAY #2. The default setting is FAULT. This relay operates the same as RELAY #1 above.

149 **LEVEL #1**

(LEVEL #1 PASSWORD)

This parameter selects the password for LEVEL #1 parameters. Refer to the PARAMETER MENU for a listing of the password level for each parameter.

NOTE: Factory default for LEVEL #1 is: 9100.

150 **LEVEL #2**

(LEVEL #2 PASSWORD)

This parameter selects the password for LEVEL #2 parameters. Refer to the PARAMETER MENU for a listing of the password level for each parameter.

NOTE: Factory default for LEVEL #2 is: 0019.

198 **LANGUAGE**

This parameter allows the display language to be changed between ENGLISH and SPANISH. When the language is changed, the effect is immediate.

The ability to change the language is also available to the operator without being in the PROGRAM MODE. Pressing the STOP key and 0 key simultaneously will bring up a message screen in the opposite language. The selected language is retained until changed, either by this parameter, or by the STOP and 0 key combination.

200 **FAULT HISTORY**

This parameter stores the ten previous fault conditions that have tripped the drive. If any faults have occurred, the fault message will be stored here. The following diagram shows what the FAULT HISTORY display looks like:

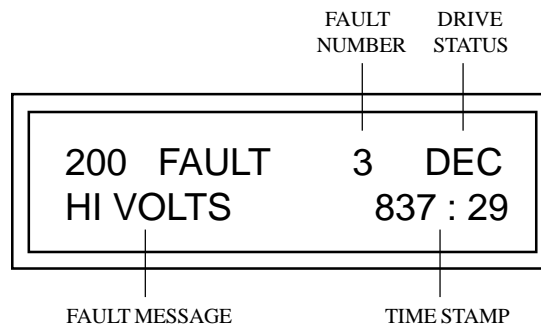

The above display indicates that the third fault was a HI VOLTS (abbreviation for HIGH DC BUS VOLTAGE) fault that occurred at 837:29 on the run time meter. The DRIVE STATUS portion of the display indicates that the drive was decelerating (DEC) when the fault occurred. Refer to Section 20.0 - TROUBLESHOOTING for a list of the possible fault messages that can appear on the display.

19.0 OPTIONS

19.1 DYNAMIC BRAKING

In applications where high inertia loads need to be decelerated quickly, or there is an overhauling load, dynamic braking may be required. High inertia and overhauling loads can regenerate voltage back into the drive, causing the DC bus voltage to rise, which eventually results in a HIGH BUS VOLTS fault. Dynamic braking dissipates this regenerated energy as heat through resistors in order to maintain the DC bus voltage below the trip level. When the dynamic braking circuitry senses that the DC bus voltage has become too high, a transistor is turned on which connects the resistors across the DC bus. The excess energy bleeds off through the resistors, bringing the DC bus voltage back down to the nominal level.

The QC Series drives can be equipped with either standard duty or heavy duty dynamic braking, depending on the requirements of the application. Some applications which typically require dynamic braking are: elevators, escalators, conveyors, large centrifugal fans, punch presses, cranes and hoists, machine tools, etc. Applications such as elevators, escalators, and cranes would require dynamic braking during periods when the load is being lowered to counteract the overhauling effects of gravity. High inertia loads such as conveyors and machine tools would need dynamic braking if quick deceleration times are required. However, if the load can be allowed to coast to a stop, dynamic braking would not be necessary.

19.1.1 STANDARD DUTY DYNAMIC BRAKING

The standard duty dynamic braking option consists of a NEMA 1 enclosure and resistors which are mounted to their own heatsink. The assembly is designed to mount on top of the QC1000 drives. For applications requiring NEMA 12 or NEMA 4 protection, refer to 19.2 - HEAVY DUTY DYNAMIC BRAKING below. Care must be taken to ensure adequate ventilation.

The resistor assembly is electrically connected to the drive using two wires, which should be run down the inside right hand side of the drive enclosure and connect to DB1 and DB2 on the power board. Connect the RED wire to DB1 and the BLUE wire to DB2.

Parameter 86 - DYNAMIC BRAKE must be ENABLED for the dynamic braking to operate.

Standard duty dynamic braking is not recommended for continuous cycling applications which require stopping inertial loads greater than twice that of the motor, or more than eight times from 1800 RPM, four times from 2500 RPM, or two times from 3600 RPM, within a five minute period.

The table below shows the additional height of the drive as a result of the standard duty braking option:

STANDARD DUTY DYNAMIC BRAKING HEIGHT ADDER			
240 / 200 Vac	480 / 400 Vac	590 / 480 Vac	ADDED HEIGHT
3 - 5 HP	1 - 7.5 HP	1 - 7.5 HP	5.27"
7.5 - 15 HP	10 - 15 HP	10 - 15 HP	6.11"

NOTE: Dynamic Braking is not available on 240 Vac, 1 HP and 2 HP drives.

19.1.2 HEAVY DUTY DYNAMIC BRAKING

The heavy duty dynamic braking option is capable of providing more frequent stopping, and stopping of higher inertia loads than the standard duty dynamic braking option. The heavy duty braking option consists of a resistor assembly and a NEMA 1 enclosure, which is designed to be mounted near the drive, but not on top of the drive. The resistors are not mounted to a heatsink, but include mounting brackets. The resistors and enclosure are shipped loose when ordered with a drive.

For NEMA 12 or NEMA 4 applications, the resistors must be mounted in an appropriate enclosure of sufficient size to dissipate the generated heat. Care must be taken to ensure adequate ventilation.

As with the standard duty braking option, two wires need to be connected to the power board in the drive. These should be run in rigid metal conduit from the braking assembly to the drive. Connect the RED wire to DB1, and the BLUE wire to DB2 on the power board.

Parameter 86 - DYNAMIC BRAKE must be ENABLED for the dynamic braking to operate.

Heavy duty dynamic braking is not recommended for continuous cycling applications which require stopping inertial loads greater than twice that of the motor, or more than eight times from 1800 RPM, four times from 2500 RPM, or two times from 3600 RPM, within a one minute period.

Heavy duty dynamic braking can provide 100% of motor torque continuously for output frequencies up to 15 Hz, 50% continuously up to 30 Hz, or 25% continuously up to 60 Hz.

Heavy duty dynamic braking can also provide 180% of motor torque for 30 seconds per minute at output frequencies up to 15 Hz, 15 seconds per minute up to 30 Hz, or 7 seconds per minute up to 60 Hz.

NOTE: Consult the factory when dynamic braking is required on drive models above 15 HP.

20.0 TROUBLESHOOTING

FAULT MESSAGES		
DISPLAY	DESCRIPTION	POSSIBLE CAUSES
OUT FAULT (1) OUT FLT1	Output transistor fault with output frequency greater than 1.5 Hz - Output current exceeded 200% of drive rating.	Phase to phase, or phase to ground short. Bad motor.
OUT FAULT (2) OUT FLT2	Output transistor fault with output frequency less than or equal to 1.5 Hz - Output current exceeded 200% of drive rating.	Bad transistor module (IPM). AUTO V or MANUAL BOOST set too high.
LO BUS VOLTS LO VOLTS	Low DC bus voltage - DC bus fell below 60% of normal.	Low line voltage.
HI BUS VOLTS HI VOLTS	High DC bus voltage - DC bus exceeded 120% of normal.	High line voltage. Overhauling load - DECEL set too fast.
CURR OVERLD CURR OVL	Current overload - Output current exceeded drive rating for too long.	Drive undersized for application. Problem with motor or driven equipment.
EMERG. STOP	Emergency stop - TB-22 to TB-2 is open.	Check devices wired between TB-22 and TB-2
POWER LOSS PWR LOSS	Input power removed and reapplied within 30 seconds.	Wait 30 seconds before applying power. Electrical noise on control wiring.
HIGH TEMP HI TEMP	High temperature - Heatsink or ambient temperature exceeded limits.	Ambient temperature is too high. Fan failure (if equipped).
DC BRAKE ERR BRK ERR1	DC braking error.	No motor connected to the drive.
DYNAM BRK OL BRK ERR2	Dynamic braking overload.	Dynamic braking applied for too long. Dynamic braking activated without braking resistors connected.
CONTROL CONTROL	Control error - New control board or software has been installed that is different than the previous version.	Use Parameter 141 - FACT PARAMS to reset the parameters to defaults. This will update the software and clear the fault.
INT ERROR (#) (# = 0-23)	Internal error - The microprocessor has sensed an internal problem.	Electrical noise on control wiring. Defective microprocessor.

The previous table indicates the possible fault messages that can appear when the drive trips into a fault condition. In the FAULT column, the fault abbreviations are shown for both the fault screen (top) and fault history (bottom). Emergency Stop faults do not appear in the fault history, therefore an abbreviation is shown only for the fault screen. The table below lists the abbreviations that are displayed to indicate the DRIVE STATUS at the time of the fault.

DRIVE STATUS INDICATIONS	
DISPLAY	DESCRIPTION
STP	Drive was in a STOP condition when the fault occurred.
ACC	Drive was accelerating when the fault occurred.
RUN	Drive was in a RUN condition when the fault occurred.
DEC	Drive was decelerating when the fault occurred.
LIM	Drive was in CURRENT LIMIT when the fault occurred.
PND	Drive was in a START PENDING condition when the fault occurred.
FLT	Drive was already in a FAULT condition when the fault occurred.
BRK	Drive was braking (DC or dynamic) when the fault occurred.

There are three methods of clearing a FAULT:

1. Press the STOP key on the keypad.
2. Open the STOP input at TB-1 on the terminal strip.
3. Remove power from the unit, wait one minute, then re-apply power.

NOTE: A FAULT can only be cleared if the condition that caused the fault has been corrected. For example, if the drive trips on a LOW VOLTS fault due to low input power, the fault cannot be reset until the input power has returned to the proper level.

21.0 USER SETTING RECORD

PARAMETER MENU: USER SETTING RECORD					
PARAM. NUMBER	PARAMETER NAME	RANGE OF ADJUSTMENT	FACTORY DEFAULT	SEE PAGE	USER SETTING
1	CURRENT LIM.	5 - 180 % (QC1000/2000) 5 - 120 % (QC3000)	180 % (QC1000/2000) 120 % (QC3000)	48	
2	TH. OVERLOAD	50 - 150 % (QC1000/2000) 50 - 120 % (QC3000)	150 % (QC1000/2000) 120 % (QC3000)	48	
3	SLIP COMP	0.0 - 5.0 %	0	48	
4	SPEED 4MA/0V	0.00 - 360.00 Hz (NOTE 1)	0.00 Hz	48	
5	SPD 20MA/10V	0.00 - 360.00 Hz (NOTE 1)	60.00 Hz	49	
9	PRE. ACC/DEC	DISABLED, ENABLED	DISABLED	49	
11 - 17	PRE #1 - #7 SPEED	MIN FREQ - MAX FREQ	10.00 Hz	49	
19	JOG SPEED	MIN FREQ - MAX FREQ	10.00 Hz	49	
20	NORMAL ACCEL	(NOTE 2)	30.0 SEC	50	
21 - 27	PRE #1 - #7 ACCEL	(NOTE 2)	30.0 SEC	50	
29	JOG ACCEL	(NOTE 2)	30.0 SEC	50	
30	NORMAL DECEL	(NOTE 2)	30.0 SEC	50	
31 - 37	PRE #1 - #7 DECEL	(NOTE 2)	30.0 SEC	51	
38	TAPER DECEL	DISABLED, ENABLED	DISABLED	51	
39	JOG DECEL	(NOTE 1)	30.0 SEC	51	
41 - 43	SKIP SPEED #1 - #3	0.00 Hz - MAX FREQ	0.00 Hz	51	
44	SKIP BAND.	0.00 - 10.00 Hz	2.00 Hz	51	
50	TB10B/D FUNC	0-10 V FREQ, 0-10 V LOAD, 4-20 MA FREQ, 4-20 MA LOAD	0-10 V FREQ	52	
51	FREQ OUT MAX	1.00 - 360.00 Hz (NOTE 1)	60.00 Hz	52	
52	TB10D R. OHM	0 - 250	250	52	
53	TB10E FUNC.	DISABLED, 0-10 V FREQ, 0-10 V LOAD, 2-10 V FREQ, 2-10 V LOAD	0 - 10 V LOAD	52	
54	LOAD OUT MAX	10 - 200 %	125 %	52	
61	MINIMUM FREQ	0.00 - 120 Hz (NOTE 1)	0.50 Hz	52	
62	MAXIMUM FREQ	0.00 - 120 Hz (NOTE 1)	60.00 Hz	53	
64	STABILITY	NORM, LOW, MED, HIGH	NORM	53	
65	COAST STOP	DISABLED, ENABLED	DISABLED	53	
66	FWD / REV	FWD ONLY, REV ONLY, FWD + REV	FWD ONLY	53	

NOTE 1: MAXIMUM SETTING IS 650 Hz FOR DRIVES WITH HIGH OUTPUT FREQUENCY OPTION.

NOTE 2: REFER TO SECTION 18.0 - DESCRIPTION OF PARAMETERS.

PARAMETER MENU: USER SETTING RECORD					
PARAM. NUMBER	PARAMETER NAME	RANGE OF ADJUSTMENT	FACTORY DEFAULT	SEE PAGE	USER SETTING
67	AUTO /MAN SEL	AUTO SPEED, MANUAL SPEED, AUTO & MAN LOCAL, AUTO & MAN SPEED	AUTO & MAN SPEED	54	
70	AUTO START	DISABLED, ENABLED	DISABLED	54	
71	RESTRT / FAULT	DISABLED, ENABLED	DISABLED	54	
72	RESTRT LIMIT	1 - 5	3	55	
73	RESTRT DELAY	1.0 - 180.0 SEC	5.0 SEC	55	
75	RESTRT DECEL	0.1 - 999.9 SEC	10.0 SEC	55	
76	RESTRT C LIM	10 - 180 %	100%	55	
80	DC BRAKE	DISABLED, CONTINUOUS, ON START, ON STOP, @ ZERO SPEED, START & STOP, ZERO SPEED & STOP	DISABLED	56	
82	DC BRK LOAD	20 - 180 %	30%	56	
83	STOP BRAKE	0.1 - 60.0 SEC	5.0 SEC	57	
84	START BRAKE	0.1 - 20.0 SEC	5.0 SEC	57	
86	DYNAM. BRAKE	DISABLED, ENABLED	DISABLED	57	
90	SPEED UNITS	HZ, RPM, % RPM, /S, /M, /H, #/S, #M, #H	HZ	57	
91	SPEED MULT.	0.10 - 400.00	30	57	
92	LOAD UNITS	% LOAD, AMPS	% LOAD	57	
93	LOAD MULT.	0.01 - 300.00	1	57	
94	AC INPUT	240 / 480 / 590, 200 / 400 / 480	240 / 480 / 590	58	
95	SPEED DP	XXXXX, XXXX.X, XXX.XX, XX.XXX, X.XXXX, .XXXXX	XXXXX	58	
100	BASE FREQUENCY	10.00 - 360.00 Hz (NOTE 1)	60.00 Hz	58	
101	VHZ CURVE	LINEAR - 1.0, VAR TORQUE - 1.3, VAR TORQUE - 1.6, VAR TORQUE - 2.0	LINEAR - 1.0 (QC1000/2000) VAR TORQUE - 1.6 (QC3000)	58	
104	AUTO V BOOST	0.0 - 20.0 %	0.0 %	59	
105	MANUAL BOOST	0.0 - 30.0 %	(NOTE 2)	59	

NOTE 1: MAXIMUM SETTING IS 1300 Hz FOR DRIVES WITH HIGH OUTPUT FREQUENCY OPTION.

NOTE 2: REFER TO SECTION 18.0 - DESCRIPTION OF PARAMETERS.

PARAMETER MENU: USER SETTING RECORD					
PARAM. NUMBER	PARAMETER NAME	RANGE OF ADJUSTMENT	FACTORY DEFAULT	SEE PAGE	USER SETTING
121	RELAY #1	NO FUNCTION, RUN,	RUN (RELAY #1)	59	
122	RELAY #2	FAULT, FAULT LOCKOUT,	FAULT (RELAY #2)	59	
124	TB-14 FUNCT	AT SPEED, ABOVE SET SPD, CURRENT LIMIT, FOLLOWER PRESENT, MAINT. TARGET, AUTO SPEED MODE, START PENDING	NO FUNCTION (TB-14)	60	
123	REL. SET SPD	0.00 - 120.00 Hz (NOTE 1)	0.50 Hz	60	
130	DRIVE POWER	0.0 - 250.0 HP	0.0 HP	60	
132	MAINT TARGET	0 - 65000 HR	0 HR	60	
133	DISPLAY FUNC	NORMAL, ACTUAL SPEED	NORMAL	60	
137	CARRIER SEL	1.5, 8, 10, 12 kHz	1.5 kHz	60	
141	FACT PARAMS	DISABLED, ENABLED	DISABLED	61	
142	CLR HISTORY	DISABLED, ENABLED	DISABLED	61	
144	S/W VERSION	(VIEW - ONLY)	(N/A)	61	
145	SERIAL COMMS	DISABLED, DETECT, MONITOR ONLY, PROGRAM, CONTROL, PROG. & CONTROL	PROGRAM	61	
146	SER. TIMEOUT	0 - 30 SEC	8 SEC	62	
147	SER. ADDRESS	1 - 247 (Modbus) 1 - 255 (Metasys)	1	62	
148	PASSWORDS	DISABLED, ENABLED	ENABLED	62	
149	LEVEL #1	0000 - 9999	9100	63	
150	LEVEL #2	0000 - 9999	0019	63	
198	LANGUAGE	ENGLISH, SPANISH	ENGLISH	63	
200	FAULT HISTORY	(VIEW - ONLY)	(N/A)	63	

NOTE 1: MAXIMUM SETTING IS 650 Hz FOR DRIVES WITH HIGH OUTPUT FREQUENCY OPTION.

AC Technology Corporation
660 Douglas Street, Uxbridge MA 01569
Sales: 800 - 217 - 9100, FAX: 508 - 278 - 7873
Service: 508 - 278 - 9100 ext 125, FAX: 508 - 278 - 6620
www.actechdrives.com