

AC Tech

member of the **Lenze** Group

Drive for Global Excellence

MCH Series Installation and Operation Manual

Table of Contents

1.0	GENERAL	1
1.1	PRODUCTS COVERED IN THIS MANUAL	1
1.2	PRODUCT CHANGES	1
1.3	WARRANTY	1
1.4	RECEIVING	1
1.5	CUSTOMER MODIFICATION	1
2.0	MCH SPECIFICATIONS	2
3.0	MCH MODEL DESIGNATION CODE	3
4.0	MCH DIMENSIONS	4
5.0	MCH RATINGS	11
6.0	THEORY	14
6.1	DESCRIPTION OF AC MOTOR OPERATION	14
6.2	DRIVE FUNCTION DESCRIPTION	16
7.0	INSTALLATION	18
8.0	INPUT AC REQUIREMENTS	20
9.0	VOLTAGE SELECTION	21
10.0	POWER WIRING	21
11.0	MCH POWER WIRING DIAGRAM	22
12.0	INITIAL POWER UP	23
13.0	KEYPAD CONTROL	25
13.1	KEYPAD FUNCTIONS (in Keypad H/O/A mode)	25
13.2	MCH DISPLAY	26
14.0	CONTROL WIRING	30
14.1	GENERAL	30
14.2	START/STOP AND SPEED CONTROL	31
15.0	MCH CONTROL WIRING DIAGRAMS	35
15.1	MCH TERMINAL STRIP	35
15.2	KEYPAD H/O/A	36
15.3	REMOTE H/O/A	37
15.4	SPEED POT AND PRESET SPEED CONTROL	38
16.0	PROGRAMMING THE MCH DRIVE	39
17.0	PARAMETER MENU	41
18.0	DESCRIPTION OF PARAMETERS	45
19.0	MCH PID SETPOINT CONTROL	75
20.0	TROUBLESHOOTING	80
	APPENDIX A - MCH WITH BYPASS OPTION	82
	APPENDIX B - MCH WITH OPTION BOX	85
	APPENDIX C - USER SETTING RECORD	87

1.0 GENERAL

1.1 PRODUCTS COVERED IN THIS MANUAL

This manual covers the AC Tech MCH Variable Frequency Drive and optional configurations. The main focus of this manual is the standard drive. Refer to Appendix A for the Bypass option, or Appendix B for the Option Box.

1.2 PRODUCT CHANGES

AC Technology Corporation reserves the right to discontinue or make modifications to the design of its products and manuals without prior notice, and holds no obligation to make modifications to products sold previously. AC Technology Corporation also holds no liability for losses of any kind which may result from this action. Instruction manuals with the most up-to-date information are available for download from the AC Tech website (www.actechdrives.com).

1.3 WARRANTY

AC Technology Corporation warrants the MCH Series AC motor control to be free of defects in material and workmanship for a period of eighteen months from the date of sale to the user, or two years from the date of shipment, whichever ever occurs first. An MCH Series control, or any component contained therein, which under normal use, becomes defective within the stated warranty time period, shall be returned to AC Technology Corporation, freight prepaid, for examination (contact AC Technology Corporation for authorization prior to returning any product). AC Technology Corporation reserves the right to make the final determination as to the validity of a warranty claim, and sole obligation is to repair or replace only components which have been rendered defective due to faulty material or workmanship. No warranty claim will be accepted for components which have been damaged due to mishandling, improper installation, unauthorized repair and/or alteration of the product, operation in excess of design specifications or other misuse, or improper maintenance. AC Technology Corporation makes no warranty that its products are compatible with any other equipment, or to any specific application, to which they may be applied and shall not be held liable for any other consequential damage or injury arising from the use of its products.

This warranty is in lieu of all other warranties, expressed or implied. No other person, firm or corporation is authorized to assume, for AC Technology Corporation, any other liability in connection with the demonstration or sale of its products.

1.4 RECEIVING

Inspect all cartons for damage which may have occurred during shipping. Carefully unpack equipment and inspect thoroughly for damage or shortage. Report any damage to carrier and/or shortages to supplier. All major components and connections should be examined for damage and tightness, with special attention given to PC boards, plugs, switches, etc.

1.5 CUSTOMER MODIFICATION

AC Technology Corporation, its sales representatives and distributors, welcome the opportunity to assist our customers in applying our products. Many customizing options are available to aid in this function. AC Technology Corporation cannot assume responsibility for any modifications not authorized by its engineering department.

2.0 MCH SPECIFICATIONS

Storage Temperature	-20° to 70° C
Ambient Operating Temperature (With 2.5, 6, and 8 kHz carrier, derate for higher carriers)	Type 1 (IP 31) -10° to 40° C
Ambient Humidity	Less than 95% (non-condensing)
Altitude	3300 feet (1000 m) above sea level without derating
Input Line Voltages	240/200 Vac, 480/400 Vac, & 590/480 Vac
Input Voltage Tolerance	+10%, -15%
Input Frequency Tolerance	48 to 62 Hz
Output Wave Form	Sine Coded PWM
Output Frequency	0-120 Hz
Carrier Frequency	2.5 kHz to 14 kHz
Frequency Stability	$\pm 0.00006\%$ / °C
Efficiency	> 97% throughout speed range
Power Factor (displacement)	> 0.96
Service Factor	1.00
Overload Current Capacity	120% of output rating for 60 seconds
Speed Reference Follower	0-10 VDC, 4-20 mA
Control Voltage	15 VDC
Analog Outputs	0 - 10 VDC, or 2 - 10 VDC Proportional to speed or load
Digital Outputs	Form C relay: 2 A at 28 VDC or 120 Vac Open-collector outputs: 40 mA at 30 VDC

3.0 MCH MODEL DESIGNATION CODE

The model number of an MCH Series drive gives a full description of the basic drive unit (see example below).

EXAMPLE: MH450BH

(MCH, 480 Vac, 5 HP, Type 1 Enclosure, with Additional Form C Relay)

	MH	4	50	B	H
Series:					
MH = MCH Series Variable Speed AC Motor Drive					
Input Voltage:					
2 = 240/200 Vac (For 208, 230, and 240 Vac; 50 or 60 Hz)					
4 = 480/400 Vac (For 380, 415, 440, 460 and 480 Vac; 50 or 60 Hz)					
5 = 590/480 Vac (For 440, 460, 480, 575 and 600 Vac; 50 or 60 Hz)					
Rating:					
10 = 1 HP (0.75 kW)		200 = 20 HP (15 kW)		1000 = 100 HP (75 kW)	
20 = 2 HP (1.5 kW)		250 = 25 HP (18.5 kW)		1250 = 125 HP (90 kW)	
30 = 3 HP (2.2 kW)		300 = 30 HP (22 kW)		1500 = 150 HP (110 kW)	
50/51 = 5 HP (3.7 kW)		400 = 40 HP (30 kW)		2000 = 200 HP (150 kW)	
75 = 7½ HP (5.5 kW)		500 = 50 HP (37.5 kW)		2500 = 250 HP (185 kW)	
100 = 10 HP (7.5 kW)		600 = 60 HP (45 kW)			
150 = 15 HP (11 kW)		750 = 75 HP (55 kW)			
Enclosure Type:					
B = NEMA 1: General Purpose, vented					
C = NEMA 4: Water-tight and Dust-tight					
D = NEMA 12: Oil-tight and Dust-tight					
E = NEMA 4X: Water-tight, Dust-tight, and Corrosion Resistant (Stainless Steel)					
Standard Options:					
H = Additional Form C relay circuit board					
<i>No character when this type of option is not specified.</i>					

NOTE: Drives equipped with Bypass or the Option Box will have a modified version of this model number format. Not all enclosure types are available when drives are equipped with Bypass or the Option Box.

4.0 MCH DIMENSIONS

NOTE: These dimensions apply to standard MCH drives. Consult the factory for dimensions of drives equipped with Bypass or the Option Box.

4.1 TYPE 1 DIMENSIONS FOR MODELS RATED UP TO 30 HP AT 240/200 Vac AND 60 HP AT 480/400 Vac AND 590 Vac

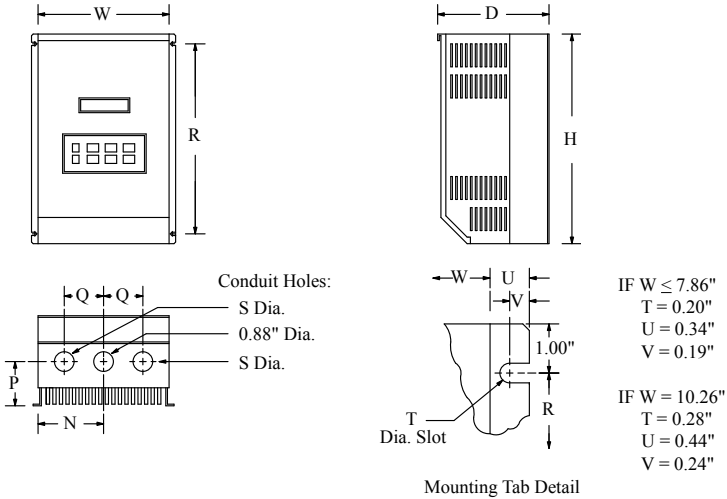

HP (kW)	INPUT VOLTAGE	MODEL	H	W	D	N	P	Q	R	S
1 (0.75)	240 / 200	MH210B	7.50	4.70	4.33	2.35	2.60	1.37	5.50	0.88
	480 / 400	MH410B	7.50	4.70	3.63	2.35	1.90	1.37	5.50	0.88
	590	MH510B	7.50	4.70	3.63	2.35	1.90	1.37	5.50	0.88
2 (1.5)	240 / 200	MH220B	7.50	6.12	5.12	3.77	3.30	1.37	5.50	0.88
	480 / 400	MH420B	7.50	6.12	4.22	3.77	2.40	1.37	5.50	0.88
	590	MH520B	7.50	6.12	4.22	3.77	2.40	1.37	5.50	0.88
3 (2.2)	240 / 200	MH230B	7.50	6.12	5.12	3.77	3.30	1.37	5.50	0.88
	480 / 400	MH430B	7.50	6.12	5.12	3.77	3.30	1.37	5.50	0.88
	590	MH530B	7.50	6.12	5.12	3.77	3.30	1.37	5.50	0.88
5 (3.7)	240 / 200	MH250B	7.88	7.86	5.94	5.13	3.95	1.50	5.88	1.13
	480 / 400	MH450B	7.50	6.12	5.12	3.77	3.30	1.37	5.50	0.88
	590	MH551B	7.88	7.86	5.94	5.13	3.95	1.50	5.88	1.13
7.5 (5.5)	240 / 200	MH275B	9.38	7.86	6.84	3.93	4.19	2.00	5.88	1.13
	480 / 400	MH475B	9.38	7.86	6.25	5.13	3.95	1.50	7.38	1.13
	590	MH575B	9.38	7.86	6.25	5.13	3.95	1.50	7.38	1.13

TYPE 1 DIMENSIONS (continued)

HP (kW)	INPUT VOLTAGE	MODEL	H	W	D	N	P	Q	R	S
10 (7.5)	240 / 200	MH2100B	11.25	7.86	6.84	3.93	4.19	2.00	7.75	1.38
	480 / 400	MH4100B	9.38	7.86	6.84	3.93	4.19	2.00	5.88	1.13
	590	MH5100B	9.38	7.86	7.40	3.93	4.19	2.00	5.88	1.13
15 (11)	240 / 200	MH2150B	12.75	7.86	6.84	3.93	4.19	2.00	9.25	1.38
	480 / 400	MH4150B	11.25	7.86	6.84	3.93	4.19	2.00	7.75	1.38
	590	MH5150B	12.75	7.86	6.84	3.93	4.19	2.00	9.25	1.38
20 (15)	240 / 200	MH2200B	12.75	10.26	7.74	5.13	5.00	2.50	9.25	1.38
	480 / 400	MH4200B	12.75	7.86	6.84	3.93	4.19	2.00	9.25	1.38
	590	MH5200B	12.75	7.86	7.40	3.93	4.19	2.00	9.25	1.38
25 (18.5)	240 / 200	MH2250B	15.75	10.26	8.35	5.13	5.00	2.50	12.25	1.38
	480 / 400	MH4250B	12.75	10.26	7.74	5.13	5.00	2.50	9.25	1.38
	590	MH5250B	12.75	10.26	7.74	5.13	5.00	2.50	9.25	1.38
30 (22)	240 / 200	MH2300B	15.75	10.26	8.35	5.13	5.00	2.50	12.25	1.38
	480 / 400	MH4300B	12.75	10.26	7.74	5.13	5.00	2.50	9.25	1.38
	590	MH5300B	12.75	10.26	8.25	5.13	5.00	2.50	9.25	1.38
40 (30)	480/400	MH4400B	15.75	10.26	8.35	5.13	5.75	2.50	12.25	1.38
	590	MH5400B	15.75	10.26	8.35	5.13	5.75	2.50	12.25	1.38
50 (37.5)	480 / 400	MH4500B	19.75	10.26	8.55	5.13	5.75	2.50	16.25	1.75
	590	MH5500B	19.75	10.26	8.55	5.13	5.75	2.50	16.25	1.75
60 (45)	480 / 400	MH4600B	19.75	10.26	8.55	5.13	5.75	2.50	16.25	1.75
	590	MH5600B	19.75	10.26	8.55	5.13	5.75	2.50	16.25	1.75

4.2 TYPE 1 DIMENSIONS FOR MODELS RATED ABOVE 30 HP AT 240/200 Vac AND 60 HP AT 480/400 Vac AND 590 Vac

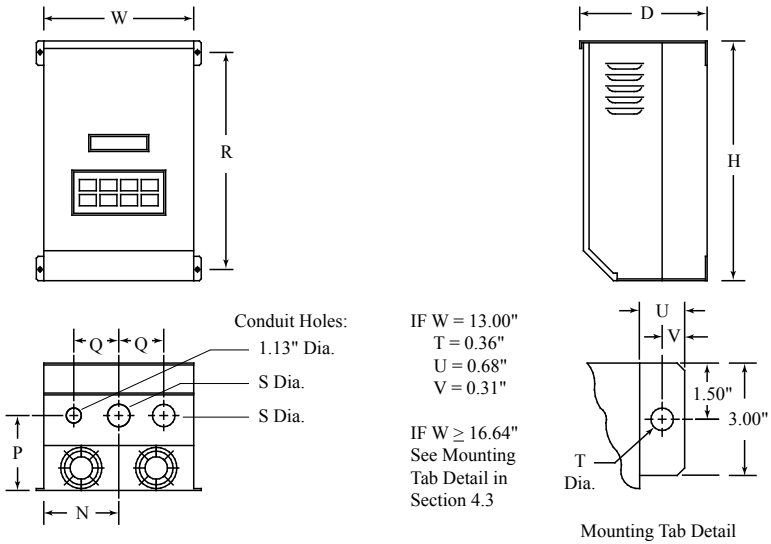

HP (kW)	INPUT VOLTAGE	MODEL	H	W	D	N	P	Q	R	S
40 (30)	240 / 200	MH2400B	25.00	13.00	10.50	5.56	6.50	2.62	22.00	1.38
50 (37.5)	240 / 200	MH2500B	25.00	13.00	10.50	5.56	6.50	2.62	22.00	1.38
60 (45)	240 / 200	MH2600B	47.00	16.64	11.85	7.14	6.88	3.12	N/A	1.75
75 (55)	480 / 400	MH4750B	29.00	16.64	11.85	7.14	6.88	3.12	N/A	1.75
	590	MH5750B	29.00	16.64	11.85	7.14	6.88	3.12	N/A	1.75
100 (75)	480/400	MH41000B	29.00	16.64	11.85	7.14	6.88	3.12	N/A	1.75
	590	MH51000B	29.00	16.64	11.85	7.14	6.88	3.12	N/A	1.75
125 (90)	480 / 400	MH41250B	29.00	24.42	11.85	11.12	6.50	4.50	N/A	2.50
	590	MH51250B	29.00	24.42	11.85	11.12	6.50	4.50	N/A	2.50
150 (110)	480 / 400	MH41500B	29.00	24.42	11.85	11.12	6.50	4.50	N/A	2.50
	590	MH51500B	29.00	24.42	11.85	11.12	6.50	4.50	N/A	2.50
200 (150)	480 / 400	MH42000B	29.00	36.66	11.85					
	590	MH52000B	29.00	36.66	11.85					
250 (185)	480 / 400	MH42500B	29.00	36.66	11.85					

See Section 4.3

4.3 CONDUIT HOLES AND MOUNTING TAB DETAIL FOR MODELS
MH42000B, MH52000B, AND MH42500B

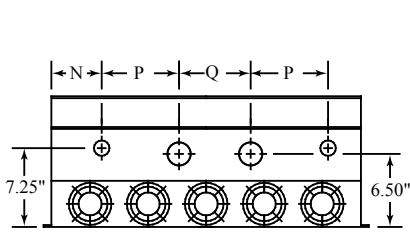

Conduit Holes: Large holes = 3.00"
Small holes = 1.13"

N = 7.45"
P = 9.00"
Q = 7.00"

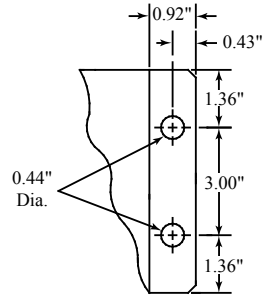

Mounting Tab Detail

4.4 TYPE 4, 4X, AND 12 DIMENSIONS FOR MODELS RATED UP TO 30 HP AT 240/200 Vac AND 60 HP AT 480/400 Vac AND 590 Vac

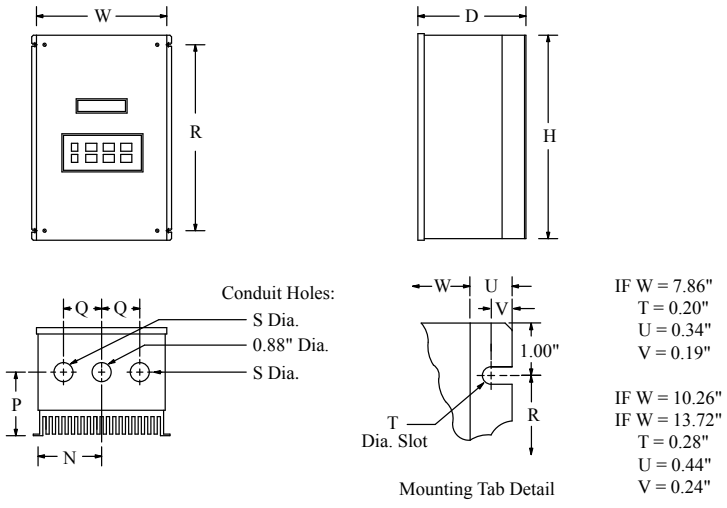

HP (kW)	INPUT VOLTAGE	MODEL*	H	W	D	N	P	Q	R	S
1 (0.75)	240 / 200	MH210	7.88	6.12	4.35	3.06	2.70	1.37	5.88	0.88
	480 / 400	MH410	7.88	6.12	4.35	3.06	2.70	1.37	5.88	0.88
	590	MH510	7.88	6.12	4.35	3.06	2.70	1.37	5.88	0.88
2 (1.5)	240 / 200	MH220	7.88	7.86	4.90	4.80	3.25	1.37	5.88	0.88
	480 / 400	MH420	7.88	7.86	4.90	4.80	3.25	1.37	5.88	0.88
	590	MH520	7.88	7.86	4.90	4.80	3.25	1.37	5.88	0.88
3 (2.2)	240 / 200	MH230	7.88	7.86	5.90	4.80	4.25	1.37	5.88	0.88
	480 / 400	MH430	7.88	7.86	4.90	4.80	3.25	1.37	5.88	0.88
	590	MH530	7.88	7.86	4.90	4.80	3.25	1.37	5.88	0.88
5 (3.7)	240 / 200	MH250	9.75	10.26	7.20	5.13	5.25	2.00	7.75	1.13
	480 / 400	MH450	7.88	7.86	5.90	4.80	4.25	1.37	5.88	0.88
	590	MH550	7.88	7.86	5.90	4.80	4.25	1.37	5.88	0.88
7.5 (5.5)	240 / 200	MH275	11.75	10.26	8.35	5.13	5.75	2.00	9.75	1.13
	480 / 400	MH475	9.75	10.26	7.20	5.13	5.25	2.00	7.75	1.13
	590	MH575	9.75	10.26	7.20	5.13	5.25	2.00	7.75	1.13
10 (7.5)	240 / 200	MH2100	13.75	10.26	8.35	5.13	5.75	2.00	11.75	1.38
	480 / 400	MH4100	11.75	10.26	8.35	5.13	5.75	2.00	9.75	1.13
	590	MH5100	11.75	10.26	8.35	5.13	5.75	2.00	9.75	1.13

TYPE 4, 4X, AND 12 DIMENSIONS (continued)

HP (kW)	INPUT VOLTAGE	MODEL *	H	W	D	N	P	Q	R	S
15 (11)	240 / 200	MH2150	15.75	10.26	8.35	5.13	5.75	2.00	13.75	1.38
	480 / 400	MH4150	13.75	10.26	8.35	5.13	5.75	2.00	11.75	1.38
	590	MH5150	13.75	10.26	8.35	5.13	5.75	2.00	11.75	1.38
20 (15)	240 / 200	MH2200D	15.75	10.26	8.35	5.13	5.75	2.00	11.75	1.38
	480 / 400	MH4200	15.75	10.26	8.35	5.13	5.75	2.00	13.75	1.38
	590	MH5200	15.75	10.26	8.35	5.13	5.75	2.00	13.75	1.38
25 (18.5)	240 / 200	MH2250D	20.25	10.26	8.35	5.13	5.75	2.00	16.25	1.38
	480 / 400	MH4250D	15.75	10.26	8.35	5.13	5.75	2.00	11.75	1.38
	590	MH5250D	15.75	10.26	8.35	5.13	5.75	2.00	11.75	1.38
30 (22)	240 / 200	MH2300D	20.25	10.26	8.35	5.13	5.75	2.00	16.25	1.38
	480 / 400	MH4300D	15.75	10.26	8.35	5.13	5.75	2.00	11.75	1.38
	590	MH5300D	15.75	10.26	8.35	5.13	5.75	2.00	11.75	1.38
40 (30)	480 / 400	MH4400D	20.25	10.26	8.35	5.13	5.75	2.00	16.25	1.38
	590	MH5400D	20.25	10.26	8.35	5.13	5.75	2.00	16.25	1.38
50 (37.5)	480 / 400	MH4500D	21.00	13.72	8.35	5.13	6.10	2.00	16.25	1.38
	590	MH5500D	21.00	13.72	8.35	5.13	6.10	2.00	16.25	1.38
60 (45)	480 / 400	MH4600D	21.00	13.72	8.35	5.13	6.10	2.00	16.25	1.38
	590	MH5600D	21.00	13.72	8.35	5.13	6.10	2.00	16.25	1.38

* MODELS WITH BLANK ENCLOSURE DESIGNATION ARE AVAILABLE IN NEMA 4

(INDICATED BY "C") OR 4X STAINLESS STEEL (INDICATED BY "E").

4.5 TYPE 12 DIMENSIONS FOR MODELS RATED ABOVE 30 HP AT 240/200 Vac AND 60 HP AT 480/400 Vac AND 590 Vac

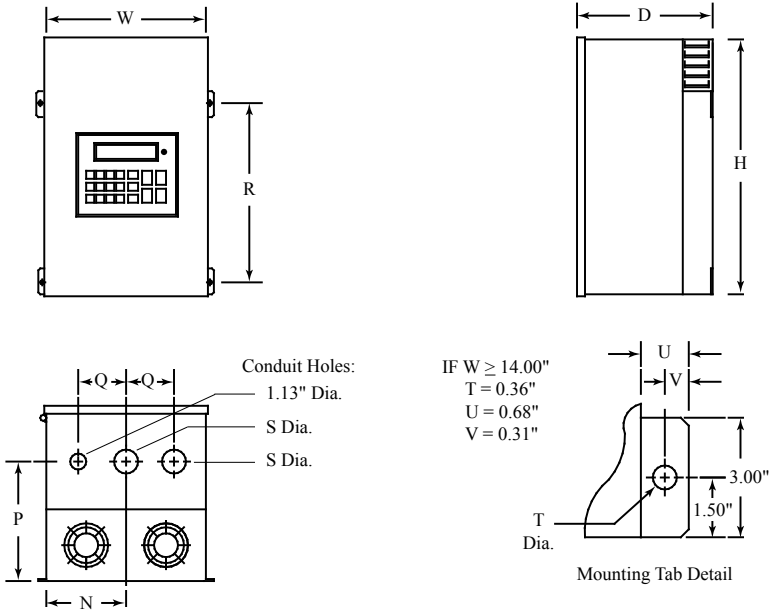

HP (kW)	INPUT VOLTAGE	MODEL	H	W	D	N	P	Q	R	S
40 (30)	240 / 200	MH2400D	31.00	14.00	11.86	6.00	7.50	2.62	22.50	1.38
50 (37.5)	240 / 200	MH2500D	31.00	14.00	11.86	6.00	7.50	2.62	22.50	1.38
60 (45)	240 / 200	MH2600D	37.00	18.00	13.30	7.50	8.00	3.13	27.00	1.75
75 (55)	480 / 400	MH4750D	37.00	18.00	13.30	7.50	8.00	3.13	27.00	1.75
	590	MH5750D	37.00	18.00	13.30	7.50	8.00	3.13	27.00	1.75
100 (75)	480 / 400	MH41000D	39.00	26.00	13.30	11.50	8.00	4.50	27.00	2.50
	590	MH51000D	39.00	26.00	13.30	11.50	8.00	4.50	27.00	2.50
125 (90)	480 / 400	MH41250D	39.00	26.00	13.30	11.50	8.00	4.50	27.00	2.50
	590	MH51250D	39.00	26.00	13.30	11.50	8.00	4.50	27.00	2.50

5.0 MCH RATINGS

The following tables indicate the input and output ratings of the MCH Series drive.

NOTE: The output current ratings are based on operation at carrier frequencies of 8 kHz and below. At full ambient temperature, operation at carrier frequencies above 8 kHz require derating the drive by multiplying the output current rating by the following factors: 0.94 at 10 kHz, 0.89 at 12 kHz, and 0.83 at 14 kHz. Refer to Parameter 23 - CARRIER FREQ in Section 18.0 - DESCRIPTION OF PARAMETERS.

MH200 SERIES RATINGS							
MODEL			INPUT (200/240 Vac, 50 - 60 Hz)			OUTPUT (0 - 200/230 Vac)	
MODEL NUMBER (NOTE 1)	FOR MOTORS RATED		INPUT PHASE	NOMINAL CURRENT (AMPS)	POWER (KVA)	NOMINAL CURRENT (AMPS)	POWER (KVA)
	HP	kW					
MH210	1	0.75	3	5.5 / 4.8	2.0	4.6 / 4.0	1.6
MH220	2	1.5	3	9.3 / 8.1	3.4	7.8 / 6.8	2.7
MH230	3	2.2	3	13.0 / 11.3	4.7	11.0 / 9.6	3.8
MH250	5	3.7	3	20 / 17.7	7.4	17.5 / 15.2	6.1
MH275	7.5	5.5	3	30 / 26	10.6	25 / 22	8.8
MH2100	10	7.5	3	37 / 32	13.2	32 / 28	11.2
MH2150	15	11	3	55 / 48	19.8	48 / 42	16.7
MH2200	20	15	3	70 / 61	25.3	62 / 54	21.5
MH2250	25	18.5	3	89 / 77	32.0	78 / 68	27.1
MH2300	30	22	3	104 / 90	37.6	92 / 80	31.9
MH2400	40	30	3	99 / 99	41.0	104 / 104	41.4
MH2500	50	37.5	3	122 / 122	50.7	130 / 130	51.8
MH2600	60	45	3	145 / 145	60.5	154 / 154	61.3

NOTE 1: See Section 3.0 for model number breakdown.

NOTE 2: See Section 8.0 for recommended fuse type.

MH400 SERIES RATINGS							
MODEL		INPUT			OUTPUT		
		(400/480 Vac, 50 - 60 Hz)			(0 - 400/460 Vac)		
MODEL NUMBER (NOTE 1)	FOR MOTORS RATED		INPUT PHASE	NOMINAL CURRENT (AMPS)	POWER (KVA)	NOMINAL CURRENT (AMPS)	POWER (KVA)
	HP	KW					
MH410	1	0.75	3	2.8 / 2.4	2.0	2.3 / 2.0	1.6
MH420	2	1.5	3	4.7 / 4.1	3.4	3.9 / 3.4	2.7
MH430	3	2.2	3	6.6 / 5.7	4.7	5.5 / 4.8	3.8
MH450	5	3.7	3	10.2 / 8.9	7.3	8.7 / 7.6	6.1
MH475	7.5	5.5	3	14.7 / 12.8	10.6	12.6 / 11.0	8.8
MH4100	10	7.5	3	18.3 / 15.9	13.2	16.0 / 14.0	11.2
MH4150	15	11	3	28 / 24	19.8	24 / 21	16.7
MH4200	20	15	3	36 / 31	25.3	31 / 27	21.5
MH4250	25	18.5	3	44 / 38	31.9	39 / 34	27.1
MH4300	30	22	3	52 / 45	37.6	46 / 40	31.9
MH4400	40	30	3	68 / 59	49.0	60 / 52	41.4
MH4500	50	37.5	3	85 / 74	61.5	75 / 65	51.8
MH4600	60	45	3	100 / 87	72.3	88 / 77	61.3
MH4750	75	55	3	91 / 91	75.5	96 / 96	76.5
MH41000	100	75	3	116 / 116	96.4	124 / 124	98.8
MH41250	125	90	3	146 / 146	121.4	156 / 156	124.3
MH41500	150	110	3	168 / 168	139.7	180 / 180	143.4
MH42000	200	150	3	225 / 225	187.1	240 / 240	191.2
MH42500	250	185	3	281 / 281	233.6	300 / 300	240.6

NOTE 1: See Section 3.0 for model number breakdown.

NOTE 2: See Section 8.0 for recommended fuse type.

MH500 SERIES RATINGS							
MODEL			INPUT			OUTPUT	
			(480/590 Vac, 50 - 60 Hz)			(0 - 460/575 Vac)	
MODEL NUMBER (NOTE 1)	FOR MOTORS RATED		INPUT PHASE	NOMINAL CURRENT (AMPS)	POWER (KVA)	NOMINAL CURRENT (AMPS)	POWER (KVA)
	HP	KW					
MH510	1	0.75	3	1.9 / 1.9	1.9	1.6 / 1.6	1.6
MH520	2	1.5	3	3.3 / 3.3	3.4	2.7 / 2.7	2.7
MH530	3	2.2	3	4.6 / 4.6	4.7	3.9 / 3.9	3.9
MH551	5	3.7	3	7.1 / 7.1	7.3	6.1 / 6.1	6.1
MH575	7.5	5.5	3	10.5 / 10.5	10.7	9.0 / 9.0	8.8
MH5100	10	7.5	3	12.5 / 12.5	12.8	11.0 / 11.0	11.0
MH5150	15	11	3	19.3 / 19.3	19.7	17.0 / 17.0	16.9
MH5200	20	15	3	25 / 25	25.4	22 / 22	21.5
MH5250	25	18.5	3	31 / 31	31.2	27 / 27	26.9
MH5300	30	22	3	36 / 36	37.1	32 / 32	31.9
MH5400	40	30	3	47 / 47	47.5	41 / 41	40.8
MH5500	50	37.5	3	59 / 59	60.3	52 / 52	51.8
MH5600	60	45	3	71 / 71	72.5	62 / 62	61.7
MH5750	75	55	3	74 / 74	75.7	77 / 77	76.7
MH51000	100	75	3	95 / 95	96.6	99 / 99	98.6
MH51250	125	90	3	119 / 119	121.6	125 / 125	124.5
MH51500	150	110	3	137 / 137	140.0	144 / 144	143.4
MH52000	200	150	3	183 / 183	187.0	192 / 192	191.2

NOTE 1: See Section 3.0 for model number breakdown.

NOTE 2: See Section 8.0 for recommended fuse type.

6.0 THEORY

6.1 DESCRIPTION OF AC MOTOR OPERATION

Three phase AC motors are comprised of two major components, the stator and the rotor. The stator is a set of three electrical windings held stationary in the motor housing. The rotor is a metal cylinder, fixed to the motor drive shaft, which rotates within the stator. The arrangement of the stator coils and the presence of three phase AC voltage give rise to a rotating magnetic field which drives the rotor. The speed at which the magnetic field rotates is known as the synchronous speed of the motor. Synchronous speed is a function of the frequency at which the voltage is alternating and the number of poles in the stator windings.

The following equation gives the relation between synchronous speed, frequency, and the number of poles:

$$S_s = 120 f/p$$

Where: S_s = Synchronous speed (rpm), f = frequency (Hz),
 p = number of poles

In three phase induction motors the actual shaft speed differs from the synchronous speed as load is applied. This difference is known as “slip”. Slip is commonly expressed as a percentage of synchronous speed. A typical value is three percent at full load.

The strength of the magnetic field in the gap between the rotor and stator is proportional to the amplitude of the voltage at a given frequency. The output torque capability of the motor is, therefore, a function of the applied voltage amplitude at a given frequency. When operated below base (rated) speed, AC motors run in the range of “constant torque”. Constant torque output is obtained by maintaining a constant ratio between voltage amplitude (Volts) and frequency (Hertz). For 60 Hz motors rated at 230, 460, and 575 Vac, common values for this V/Hz ratio are 3.83, 7.66, and 9.58 respectively. Operating with these V/Hz ratios generally yields optimum torque capability. Operating at lower ratio values results in lower torque and power capability. Operating at higher ratio values will cause the motor to overheat. Most standard motors are capable of providing full torque output from 3 to 60 Hz. However, at lower speeds, where motor cooling fans become less effective, supplemental cooling may be needed to operate at full torque output continuously.

If the frequency applied to the motor is increased while the voltage remains constant, torque capability will decrease as speed increases. This will cause the horsepower capability of the motor to remain approximately constant. Motors run in this mode when operated above base speed, where drive output voltage is limited by the input line voltage. This operating range is known as the “constant horsepower” range. The typical maximum range for constant horsepower is about 2.3 to 1 (60 to 140 Hz). The diagram below depicts the characteristics of a typical AC induction motor with a 60 Hz base speed.

WARNING!

Consult motor manufacturer before operating motor and/or driven equipment above base speed.

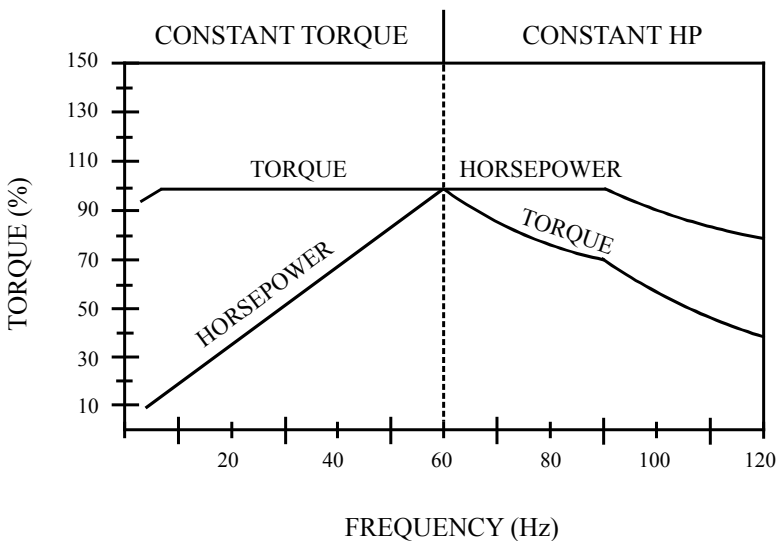

6.1.1 VARIABLE TORQUE VS. CONSTANT TORQUE

Variable frequency drives, and the loads they are applied to, can generally be divided into two groups: constant torque and variable torque. Constant torque loads include: vibrating conveyors, punch presses, rock crushers, machine tools, and just about every other application that is not considered variable torque. Variable torque loads include centrifugal pumps and fans, which make up the majority of HVAC applications.

Variable torque loads are governed by the affinity laws, which define the relationships between speed, flow, torque and horsepower. The diagram below illustrates these relationships:

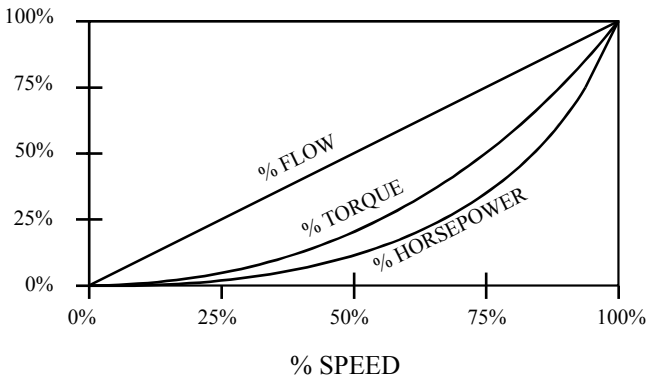

“Variable torque” refers to the fact that the torque required varies with the square of the speed. Also, the horsepower required varies with the cube of the speed, resulting in a large reduction in horsepower for even a small reduction in speed. It is easily seen that substantial energy savings can be achieved by reducing the speed of a fan or pump. For example, reducing the speed to 50% results in a 50 HP motor having to produce only 12.5% of rated horsepower, or 6.25 HP. Variable torque drives usually have a low overload capacity (110% - 120% for 60 seconds), because variable torque applications rarely experience overload conditions. To optimize efficiency and energy savings, variable torque drives are usually programmed to follow a variable V/Hz ratio.

The term “constant torque” is not entirely accurate in terms of the actual torque required for an application. Many constant torque applications have reciprocating loads, such as vibrating conveyors and punch presses, where the rotational motion of the motor is being converted to a linear motion. In such cases, the torque required can vary greatly at different points in the cycle. For constant torque loads, this fluctuation in torque is not a direct function of speed, as it is with a variable torque load. As a result, constant torque drives typically have a high overload rating (150% for 60 seconds) in order to handle the higher peak torque demands. To achieve maximum torque, constant torque drives follow a constant V/Hz ratio.

The MCH Series has an overload capacity of 120% for one minute, indicating that it is meant for variable torque loads.

6.2 DRIVE FUNCTION DESCRIPTION

The MC Series is a microprocessor based, keypad programmable, variable speed AC motor drive. There are four major sections: an input diode bridge and filter, a power board, a control board, and an output intelligent power module.

6.2.1 DRIVE OPERATION

Incoming AC line voltage is converted to a pulsating DC voltage by the input diode bridge. The DC voltage is supplied to the bus filter capacitors through a charge circuit which limits inrush current to the capacitors during power-up. The pulsating DC voltage is filtered by the bus capacitors which reduces the ripple level. The filtered DC voltage enters the inverter section of the drive, composed of six output intelligent insulated gate bi-polar transistors (IGBTs) which make up the three output legs of the drive. Each leg has one intelligent IGBT connected to the positive bus voltage and one connected to the negative bus voltage. Alternately switching on each leg, the intelligent IGBT produces an alternating voltage on each of the corresponding motor windings. By switching each output intelligent IGBT at a very high frequency (known as the carrier frequency) for varying time intervals, the inverter is able to produce a smooth, three phase, sinusoidal output current wave which optimizes motor performance.

6.2.2 CIRCUIT DESCRIPTION

The control section consists of a control board with a microprocessor, keypad and display. Drive programming is accomplished via the keypad or the serial communications port. During operation the drive can be controlled via the keypad, by control devices wired to the control terminal strip, or by the the serial communications port. The Power Board contains the control and protection circuits which govern the six output IGBTs. The Power Board also contains a charging circuit for the bus filter capacitors, a motor current feedback circuit, a voltage feedback circuit, and a fault signal circuit. The drive has several built in protection circuits. These include phase-to-phase and phase-to-ground short circuit protection, high and low line voltage protection, protection against excessive ambient temperature, and protection against continuous excessive output current. Activation of any of these circuits will cause the drive to shut down in a fault condition.

6.2.3 MCH INPUTS & OUTPUTS

The drive has two analog inputs (0-10 VDC and 4-20 mA) that can be used for speed reference, PID setpoint reference, or PID feedback. A speed potentiometer (10,000 Ohm) can be used with the 0-10 VDC input.

There are also two analog outputs: one is proportional to speed (frequency), and the other is proportional to load.

The standard MCH drive has three programmable outputs for status indication: one Form C Relay and two open-collector outputs.

Refer to Sections 14.0 - CONTROL WIRING and 15.0 - MCH CONTROL WIRING DIAGRAMS for more information.

7.0 INSTALLATION

WARNING!

DRIVES MUST NOT BE INSTALLED WHERE SUBJECTED TO ADVERSE ENVIRONMENTAL CONDITIONS! DRIVES MUST NOT BE INSTALLED WHERE SUBJECTED TO: COMBUSTIBLE, OILY, OR HAZARDOUS VAPORS OR DUST; EXCESSIVE MOISTURE OR DIRT; STRONG VIBRATION; EXCESSIVE AMBIENT TEMPERATURES. CONSULT AC TECHNOLOGY FOR MORE INFORMATION ON THE SUITABILITY OF A DRIVE TO A PARTICULAR ENVIRONMENT.

The drive should be mounted on a smooth vertical surface capable of safely supporting the unit without vibrating. The LCD display has an optimum field of view, this should be considered when determining the mounting position.

Maintain a minimum spacing around the drive as follows:

SPACING REQUIREMENTS		
HP	SPACING	
	INCHES	mm
0.25 - 5	2	50
7.5 - 25	4	100
30 - 60	6	150
75 - 250	8	200

All drive models **MUST** be mounted in a vertical position for proper heatsink cooling. Fans or blowers should be used to insure proper cooling in tight quarters. Do not mount drives above other drives or heat producing equipment that would impede the cooling of the drive. Note the ambient operating temperature ratings for each drive model.

If it is necessary to drill or cut the drive enclosure or panel, extreme care must be taken to avoid damaging drive components or contaminating the drive with metal fragments (which cause shorting of electrical circuits). Cover drive components with a clean cloth to keep out metal chips and other debris. Use a vacuum cleaner to clean drive components after drilling, even if chips do not appear to be present. Do not attempt to use positive air pressure to blow chips out of drive, as this tends to lodge debris under electronic components. Contaminating the drive with metal chips can cause drive failure and will void the warranty.

7.1 INSTALLATION AFTER A LONG PERIOD OF STORAGE

WARNING!

Severe damage to the drive can result if it is operated after a long period of storage or inactivity without reforming the DC bus capacitors!

If input power has not been applied to the drive for a period of time exceeding three years (due to storage, etc), the electrolytic DC bus capacitors within the drive can change internally, resulting in excessive leakage current. This can result in premature failure of the capacitors if the drive is operated after such a long period of inactivity or storage.

In order to reform the capacitors and prepare the drive for operation after a long period of inactivity, apply input power to the drive for 8 hours prior to actually operating the motor.

7.2 EXPLOSION PROOF APPLICATIONS

Explosion proof motors that are not rated for inverter use lose their certification when used for variable speed. Due to the many areas of liability that may be encountered when dealing with these applications, the following statement of policy applies:

“AC Technology Corporation inverter products are sold with no warranty of fitness for a particular purpose or warranty of suitability for use with explosion proof motors. AC Technology Corporation accepts no responsibility for any direct, incidental or consequential loss, cost, or damage that may arise through the use of its AC inverter products in these applications. The purchaser expressly agrees to assume all risk of any loss, cost, or damage that may arise from such application.”

8.0 INPUT AC REQUIREMENTS

WARNING!

Hazard of electrical shock! Disconnect incoming power and wait three minutes before servicing the drive. Capacitors retain charge after power is removed.

8.1 INPUT AC POWER REQUIREMENTS

8.1.1 VOLTAGE

The input voltage must match the drive's nameplate voltage rating. Voltage fluctuation must not vary by greater than 10% overvoltage or 15% undervoltage.

NOTE: Drives with dual rated input voltage must be programmed for the proper supply voltage. Refer to Parameter 0 - LINE VOLTS in Section 18.0 - DESCRIPTION OF PARAMETERS.

The drive is suitable for use on a circuit capable of delivering not more than 200,000 RMS symmetrical amperes, at the drive's rated voltage.

Three phase voltage imbalance must be less than 2.0% phase to phase. Excessive phase to phase imbalance can cause severe damage to the drive's power components.

Motor voltage should match line voltage in normal applications. The drive's maximum output voltage will equal the input voltage. Use extreme caution when using a motor with a voltage rating which is different from the input line voltage.

8.1.2 SUPPLY TRANSFORMER kVA RATINGS

If the kVA rating of the AC supply transformer is greater than ten times the input kVA rating of the drive, a drive isolation transformer, or a 2 - 3% input line reactor (also known as a choke) must be added.

8.2 INPUT FUSING AND DISCONNECT REQUIREMENTS

A circuit breaker or a disconnect switch with fuses must be provided in accordance with the National Electric Code (NEC) and all local codes.

The MCH drive is capable of withstanding up to 120% current overload for 60 seconds. Select a fuse or magnetic trip circuit breaker rated at 1.25 times the input current rating of the drive (the minimum size should be 10 amps, regardless of input current rating). Refer to Section 5.0 – MCH RATINGS.

Minimum voltage rating of the protection device should be 250 Vac for 240/200 Vac rated drives, and 600 Vac for 480/400 Vac and 590/480 Vac drives.

Current limiting type fuses should be used when input fusing is required. Select fuses with low I^2T values, rated at 200,000 AIC. Recommended fuses are Bussman type KTK-R, J2N, and J2S. Similar fuses with equivalent ratings by other manufacturers may also be acceptable.

9.0 VOLTAGE SELECTION

MH200 Series drives are rated for 240/200 Vac, 50-60 Hz input. The drive will function with input voltages of 200 to 240 Vac (+ 10%, - 15%), at 48 to 62 Hz.

MH400 Series drives are rated for 480/400 Vac, 50-60 Hz input. The drive will function with input voltages of 400 to 480 Vac (+ 10%, - 15%), at 48 to 62 Hz.

MH500 Series drives are rated for 590/480 Vac, 50-60 Hz input. The drive will function with input voltages of 480 to 590 Vac (+ 10%, - 15%), at 48 to 62 Hz.

10.0 POWER WIRING

WARNING!

Hazard of electrical shock. Disconnect incoming power and wait three minutes before servicing the drive. Capacitors retain charge after power is removed.

Note drive input and output current ratings and check applicable electrical codes for required wire type and size, grounding requirements, overcurrent protection, and incoming power disconnect, before wiring the drive. Size conservatively to minimize voltage drop.

Input fusing and a power disconnect switch or contactor **MUST** be wired in series with terminals L1, L2, and L3. If one has not been supplied by AC Technology Corporation, a disconnect means must be wired during installation. This disconnect must be used to power down the drive when servicing, or when the drive is not to be operated for a long period of time, but should not be used to start and stop the motor.

Repetitive cycling of a disconnect or input contactor (more than once every two minutes) may cause damage to the drive.

All three power output wires, from terminals T1, T2, and T3 to the motor, must be kept tightly bundled and run in a separate conduit away from all other power and control wiring.

Do not install contactors between the drive and motor without consulting AC Technology Corporation for more information. Operating such devices while the drive is running can potentially cause damage to the drive's power components. If such a device is required, it should only be operated when the drive is in a STOP state.

11.0 MCH POWER WIRING DIAGRAM

This diagram applies to standard MCH drives. Refer to Appendix A for Bypass power wiring, or Appendix B for Option Box power wiring.

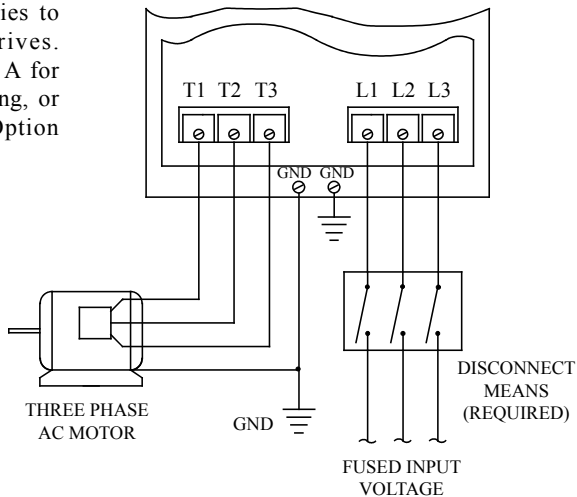

WARNING!

Do not connect incoming AC power to output terminals T1, T2, or T3. Severe damage to the drive will result.

INSTALL, WIRE, AND GROUND IN ACCORDANCE WITH ALL APPLICABLE CODES.

NOTES:

1. Wire the motor for the proper voltage per the output rating of the drive. Motor wires **MUST** be run in a separate steel conduit away from control wiring and incoming AC power wiring.
2. Do not install contactors between the drive and the motor without consulting AC Technology for more information. Failure to do so may result in drive damage.
3. Remove any existing, and do not install, power factor correction capacitors between the drive and the motor. Failure to do so will result in drive damage.
4. Use only UL and CSA listed and approved wire.
5. Minimum wire voltage ratings: 300 V for 200 and 240 Vac systems, and 600 V for 400, 480, and 590 Vac systems.
6. Wire guage must be based on a minimum of 125% of the rated output current of the drive, and a minimum 75°C insulation rating. Use copper wire only.
7. Wire and ground in accordance with NEC or CEC, and all applicable local codes.

12.0 INITIAL POWER UP

WARNING!

Hazard of electrical shock! Wait three minutes after disconnecting incoming power before servicing drive. Capacitors retain charge after power is removed.

Before attempting to operate the drive, motor, and driven equipment be sure all procedures pertaining to installation and wiring have been properly followed.

WARNING!

Severe damage to the drive can result if it is operated after a long period of storage or inactivity without reforming the DC bus capacitors!

If input power has not been applied to the drive for a period of time exceeding three years (due to storage, etc), the electrolytic DC bus capacitors within the drive can change internally, resulting in excessive leakage current. This can result in premature failure of the capacitors if the drive is operated after such a long period of inactivity or storage.

In order to reform the capacitors and prepare the drive for operation after a long period of inactivity, apply input power to the drive for 8 hours prior to actually operating the motor.

Disconnect the driven load from the motor. Verify that the drive input terminals (L1, L2, and L3) are wired to the proper input voltage per the nameplate rating of the drive.

WARNING!

DO NOT connect incoming AC power to output terminals T1, T2, and T3! Do not cycle input power to the drive more than once every two minutes. Damage to the drive will result.

Energize the incoming power line. The LCD display should light and flash "TESTING" and then show the voltage and horsepower rating of the drive. The display should then look like the example display below, which indicates that the drive is in a STOP state, the speed setpoint is 20.00 Hz, and there is no load (because it is not running):

KSTOP	>	20.00	HZ
0 %	LOAD		OFF

NOTE: If the drive is equipped with Bypass, the drive will not power up unless the Drive Mode/Off/Bypass Mode switch is in the Drive Mode position, or the Drive Test/Off/Drive Normal switch is in the Drive Test position.

If the display does not appear, remove the incoming power, wait three minutes for the bus capacitors to discharge, and verify correct installation and wiring. If the wiring is correct, re-apply incoming power and note the display for drive status. If the display still does not appear call the factory for assistance.

Follow the procedure given below to check the motor rotation:

1. Use the ▼ key to decrease the speed setpoint to the minimum value allowed (0.50 Hz if Parameter 10 - MIN FREQ has not been changed).
2. Press the HAND (START) key. The drive should indicate RUN, but if the speed setpoint is 0.50 Hz, the motor may not rotate. Press the ▲ key to increase the speed setpoint until the motor starts to rotate.
3. If the motor is rotating in the wrong direction, press the OFF (STOP) key and remove power from the drive. Wait three minutes for the bus capacitors to discharge, and swap any two of the motor wires connected to T1, T2, and T3.

NOTE 1: The drive is phase insensitive with respect to incoming line voltage. Therefore, to change the motor rotation, the phases must be swapped at the drive output terminals or at the motor.

NOTE 2: If the drive is equipped with the Bypass option, motor rotation must be checked in both drive mode and bypass mode:

To check rotation in Drive mode:

1. Select Drive Mode using the Drive Mode/Off/Bypass Mode switch.
2. Select Drive Normal using the Drive Test/Off/Drive Normal switch.
3. Select HAND using the HAND/OFF/AUTO switch. The drive should start, allowing the motor rotation to be checked.

To check rotation in Bypass mode:

1. Select Bypass Mode using the Drive Mode/Off/Bypass Mode switch.
2. Select Drive Normal using the Drive Test/Off/Drive Normal switch.
3. Momentarily put the Hand/Off/Auto switch into Hand to "bump" the motor so rotation can be checked.

If rotation is incorrect in both modes, swap any two motor leads at the output terminals (thermal overload terminals).

If rotation is correct in drive mode, but incorrect in bypass mode, swap any two leads at the main input power terminals.

If rotation is incorrect in drive mode, but correct in bypass mode, swap any two leads at the main input terminals AND any two leads at the output terminals (thermal overload terminals).

13.0 KEYPAD CONTROL

The drive can be operated in a number of different ways: keypad (HAND), control devices wired to the terminal strip (AUTO), serial communications (SERIAL), or combinations of each. The drive should first be operated in HAND mode during initial start-up. Refer to Sections 14.0 - CONTROL WIRING, and 18.0 - DESCRIPTION OF PARAMETERS for information on remote (AUTO) operation.

13.1 KEYPAD FUNCTIONS (in Keypad H/O/A mode)

HAND (START)	To start the drive, press the HAND (START) key.
OFF (STOP)	To stop the drive, press the OFF (STOP) key. NOTE: The OFF (STOP) key is active in both HAND and AUTO modes.
AUTO (START)	Puts the drive into AUTO mode. Close TB-1 to TB-2 to start the drive. Open TB-1 to TB-2 to stop the drive.
SPEED SOURCE	Selects the speed reference source. Press this key to select the desired speed reference, and then press the ENTER key within three seconds to confirm the change. The choices are described below: HAND ONLY: Drive speed is determined by the setting of Parameter 29 - HAND SOURCE. AUTO ONLY: Drive speed is determined by the setting of Parameter 24 - AUTO SOURCE. NORM SRC: In HAND mode, speed is determined by the setting of Parameter 29 - HAND SOURCE. In AUTO mode, speed is determined by the setting of Parameter 24 - AUTO SOURCE.
SPEED SETPOINT	To increase the speed setpoint, press the ▲ key. To decrease the speed setpoint, press the ▼ key. NOTE: The ▲ and ▼ keys are only active if another speed reference source is not selected.
FAULT RESET	Use the OFF (STOP) key to reset a fault. If the fault condition has passed, pressing the STOP key will clear the fault and return the drive to a STOP condition. NOTE: If an OUTPUT fault occurs, there will be a 30 second delay before the fault can be cleared using the STOP key.

13.2 MCH DISPLAY

The following describes the possible display configurations for the MCH Series drive when operating as a standard drive (without PID control). Refer to Section 19.0 - MCH PID SETPOINT CONTROL for a complete description of drive operation when using PID control.

13.2.1 MCH DISPLAY IN STOP MODE

When the drive is in the STOP mode, there are two possible displays: load and motor voltage. The standard display indicates % LOAD, which is shown

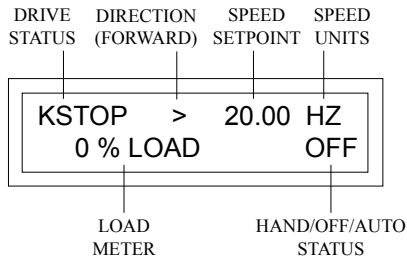

NOTE: See Parameter 31 - UNITS for the SPEED UNITS display options.

Pressing the ENTER key will change the display from the % LOAD indication to the VAC (motor voltage) indication:

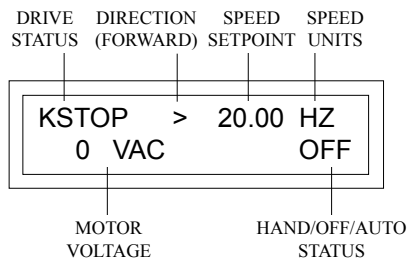

Pressing ENTER again will change the display back to the % LOAD indication.

The following table shows the possible DRIVE STATUS indications that can appear on the drive display:

DRIVE STATUS TABLE	
DISPLAY	DESCRIPTION
KSTOP	KEYPAD STOP - The drive was stopped using the OFF (STOP) key.
RSTOP	REMOTE STOP - The drive was stopped by opening TB-1 to TB-2.
SSTOP	SERIAL STOP - The drive was stopped through the serial link.
RUN	Drive is in RUN mode and is within ± 0.5 Hz of the speed setpoint.
FAULT	Drive has shut down due to a FAULT condition. If the fault condition has passed, pressing the HAND (OFF) key will clear the fault and return the drive to the STOP mode.
LOCK	Drive is in FAULT LOCKOUT after five unsuccessful restart attempts.
BRAKE	DC BRAKE is energized.
LIMIT	Drive is in CURRENT LIMIT due to an overloaded motor, or ACCEL is set too fast.
F DEC	Drive is in DECEL FREEZE because DECEL is set too fast.

13.2.2 MCH DISPLAY IN RUN MODE

When the drive is in the RUN mode, the default display will look like this:

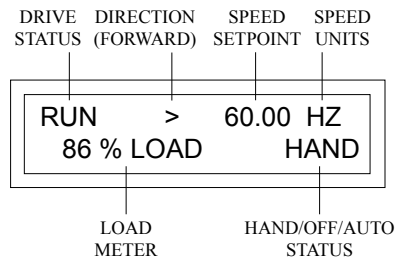

As in the STOP mode, the ENTER key can be used to toggle the display from % LOAD to VAC (motor voltage):

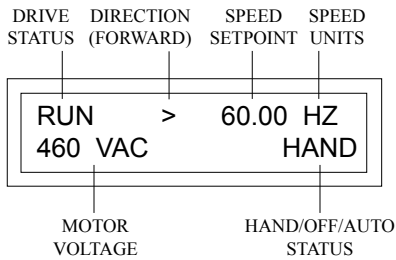

NOTE: During acceleration and deceleration to the SPEED SETPOINT, the DRIVE STATUS will show the actual drive speed. When the SPEED SETPOINT is reached, the DRIVE STATUS will change to RUN (or STOP if the drive is decelerating to a STOP).

13.2.3 MCH DISPLAY IN FAULT MODE

When the drive trips on a fault, the display will automatically change to the FAULT display, which indicates the FAULT MESSAGE:

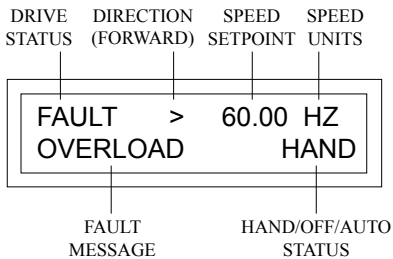

In FAULT mode, the ENTER key will toggle the display between three screens: FAULT, % LOAD and VAC. The DRIVE STATUS for these displays will be FAULT. An example is shown below of the drive in the FAULT mode displaying % LOAD:

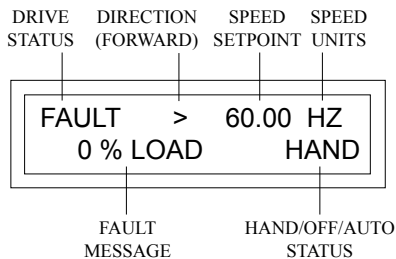

NOTE: To clear a FAULT, press the OFF (STOP) key, issue a remote STOP command at TB-1, or use TB-13D (refer to Parameter 50 - TB13D INPUT).

13.2.4 MCH DISPLAY IN AUXILIARY MODE

If the ENTER key is held down, the display will enter the auxiliary mode and cycle between two displays: a CONTROL display that indicates the H/O/A source (keypad or terminal strip), speed reference source, and the setting of the SPEED SOURCE key on the keypad; and a TIME/kWh display that indicates total elapsed run time and kilowatt hours. When the ENTER key is released, the display will return to the previous screen. Examples of these displays are shown below:

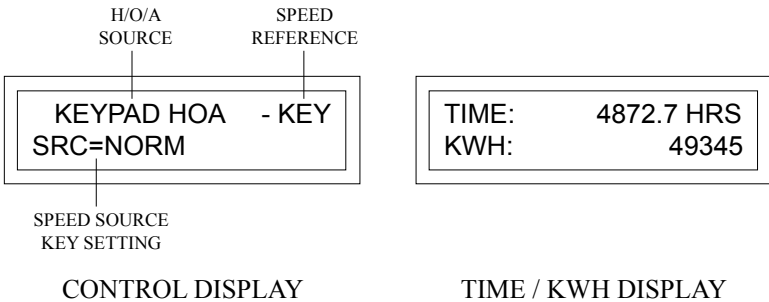

The table below shows the possible SPEED REFERENCE SOURCE indications for the CONTROL display in the auxiliary mode:

SPEED REFERENCE SOURCE TABLE	
DISPLAY	DESCRIPTION
KEY	KEYPAD - ▲ and ▼ keys.
VDC	0 - 10 VDC analog input at TB-5A (In PID mode, this indicates that the SETPOINT reference is a 0-10 VDC signal).
IDC	4 - 20 mA analog input at TB-5B (In PID mode, this indicates that the SETPOINT reference is a 4-20 mA signal).
SP#1 - SP#4	PRESET SPEED #1 - PRESET SPEED #4
MKB	MANUAL KEYBOARD - The ▲ and ▼ keys are used for speed control. This occurs in PID mode when the drive is put into HAND (open-loop) mode.
AKB	AUTO KEYBOARD - The ▲ and ▼ keys are used as the PID SETPOINT reference. This occurs in PID mode when the drive is put into AUTO (closed-loop) mode.

14.0 CONTROL WIRING

14.1 GENERAL

This section describes control wiring for standard MCH drives. Refer to Appendix A for control wiring for the Bypass option, or Appendix B for control wiring for the Option Box.

14.1.1 KEYPAD CONTROL

The drive can be controlled by the keypad or by control devices wired to the terminal strip. The drive will run from the keypad “out of the box”, requiring no connections to the terminal strip. Refer to Section 13.0 - KEYPAD CONTROL.

14.1.2 CONTROL WIRING VS. POWER WIRING

External control wiring **MUST** be run in a separate conduit away from all other input and output power wiring. If control wiring is not kept separate from power wiring, electrical noise may be generated on the control wiring that will cause erratic drive behavior. Use twisted wires or shielded cable grounded at the drive chassis **ONLY**. Recommended control wire is Belden 8760 (2-wire) or 8770 (3-wire), or equivalent.

Torque the control terminals to 2 lb-in (0.2 Nm). Be careful not to overtorque the terminals, as this will cause damage to the terminal strip. This is not covered under warranty and can only be repaired by replacing the control board.

14.1.3 TB-2: CIRCUIT COMMON

The TB-2 terminals are used as circuit common for the start/stop, input select, analog input, and analog output functions. There are three TB-2 terminals available on the terminal strip, and they are all internally connected to each other on the main control board. If necessary TB-2 may be connected to chassis ground.

NOTE: TB-2 **MUST** be connected to chassis ground when using serial communications.

14.1.4 SURGE SUPPRESSION ON RELAYS

Current and voltage surges and spikes in the coils of contactors, relays, solenoids, etc, near or connected to the drive, can cause erratic drive operation. Therefore, a snubber circuit should be used on coils associated with the drive. For AC coils, snubbers should consist of a resistor and a capacitor in series across the coil. For DC coils, a free-wheeling or flyback diode should be placed across the coil. Snubbers are typically available from the manufacturer of the device.

14.2 START/STOP AND SPEED CONTROL

14.2.1 START/STOP CONTROL IN KEYPAD H/O/A MODE

In Keypad H/O/A mode, the HAND (START) and AUTO (START) keys on the keypad are used to select HAND and AUTO modes. When the HAND (START) key is pressed, HAND mode is selected and the drive starts immediately. When the drive is put into AUTO mode, it will respond to an external start/stop command. This is done as follows:

1. Press the AUTO key on the keypad. The H/O/A STATUS portion of the display will indicate AUTO.
2. Wire a normally open maintained contact between TB-1 and TB-2 on the terminal strip. Close the contact to start the drive, and open the contact to stop the drive.

Refer to the wiring diagram in Section 15.2.

14.2.2 START/STOP CONTROL IN REMOTE H/O/A MODE

In Remote H/O/A mode, the terminal strip is used to select HAND and AUTO modes. This is done as follows:

1. Program TB-13C (Parameter 49) to HAND. Once this is done, the HAND (START) and AUTO (START) keys on the keypad will be disabled.
2. Wire a contact between TB-13C and TB-2. Close this contact to select HAND mode.
NOTE: When HAND mode is selected, TB-1 must be closed to TB-2 to allow the drive to run. Therefore, when TB-13C is closed to TB-2, TB-1 must also be closed to TB-2 by some means (another set of contacts, etc).
3. Wire a contact between TB-12A and TB-2. Close this contact to select AUTO mode.
4. Wire a normally open maintained contact between TB-1 and TB-2. In AUTO mode (TB-12A closed to TB-2), close this contact to start the drive and open this contact to stop the drive.

Refer to the wiring diagram in Section 15.3.

NOTE: If the drive is operating in Remote H/O/A mode, and the OFF (STOP) key on the keypad is used to stop the drive (instead of using the OFF position of the remote H/O/A switch), the HAND (START) or AUTO (START) key must be pressed to cancel the keypad stop and allow the drive to start again.

14.2.3 SPEED REFERENCE SIGNALS

The drive allows for three analog speed reference inputs: a speed potentiometer (10,000 Ohm), 0-10 VDC, or 4-20 mA.

SPEED POT Connect the wiper to terminal TB-5A, and connect the high and low end leads to terminals TB-6 and TB-2, respectively.

0-10 VDC Wire the positive to terminal TB-5A and the negative to terminal TB-2. TB-5A input impedance is 200 kilohms.

4-20 mA Wire the positive to terminal TB-5B and the negative to terminal TB-2. TB-5B input impedance is 100 Ohms.

14.2.4 SPEED REFERENCE SELECTION

In HAND mode, the speed reference source will be determined by the setting of Parameter 29 - HAND SOURCE.

In AUTO mode, the speed reference source will be determined by the setting of Parameter 24 - AUTO SOURCE.

The SPEED SOURCE key on the keypad can be used to change the speed reference source. When NORM SRC is selected, the above statements are true. However, the SPEED SOURCE key can also be used to select HAND ONLY or AUTO ONLY, which forces the drive speed to be controlled from the HAND SOURCE (Parameter 29) or the AUTO SOURCE (Parameter 24), regardless of whether the drive is in HAND or AUTO mode.

Speed references can also be selected using TB-13A, 13B, and 13C on the terminal strip. If HAND SOURCE and/or AUTO SOURCE are set to SELECTED, the speed source will be whatever speed reference is selected using TB-13A, 13B, or 13C (0-10 VDC, 4-20 mA, preset speeds, etc). Refer to Parameters 47, 48, and 49 in Section 18.0 - DESCRIPTION OF PARAMETERS.

0 - 10 VDC and 4 - 20 mA INPUT SIGNALS

HAND SOURCE (Parameter 29) and AUTO SOURCE (Parameter 24) can be set for 0-10 VDC or 4-20 mA.

If HAND SOURCE and/or AUTO SOURCE are set to SELECTED, TB-13A, TB-13B, and TB-13C can all be used to select 0-10 VDC or 4-20 mA input.

PRESET SPEEDS

HAND SOURCE (Parameter 29) and AUTO SOURCE (Parameter 24) can be set to PRESET #1 - PRESET #4.

If HAND SOURCE and/or AUTO SOURCE are set to SELECTED, TB-13A can be programmed to select PRESET #1, TB-13B to select PRESET #2, and TB-13C to select PRESET #3. Closing any two of these terminals to TB-2 will select PRESET #4. Refer to Parameters 1-4: PRESET #1 - #4 in Section 18.0 - DESCRIPTION OF PARAMETERS.

MOP - MOTOR OPERATED POT

MOP allows the drive speed to be adjusted using contact closures (one for increase and another for decrease).

HAND SOURCE (Parameter 29) and AUTO SOURCE (Parameter 24) can be set to MOP. This requires that TB-13A (Parameter 47) be set to DECREASE FREQ, and TB-13B (Parameter 48) be set to INCREASE FREQ. Close TB-13A to TB-2 to decrease the drive speed, and close TB-13B to TB-2 to increase the drive speed. Once the desired speed is reached, release the contact, and the drive speed will hold at that value. The DECREASE FREQ function will work when the drive is in a STOP or RUN mode. The INCREASE FREQ function will only work while the drive is in a RUN mode.

If HAND SOURCE and/or AUTO SOURCE is set to SELECTED, TB-13A and TB-13B can be programmed for this function. Program TB-13A (Parameter 47) to DECREASE FREQ, and TB-13B (Parameter 48) to INCREASE FREQ. Refer to the description of operation above .

NOTE: If TB-13A, TB-13B, and TB-13C are all programmed to select speed references, and two or three of the terminals are closed to TB-2, the higher terminal has priority and will override the others. For example, if TB-13A is programmed to select 0-10VDC, and TB-13C is programmed to select PRESET #3, closing both terminals to TB-2 will cause the drive to respond to PRESET #3, because TB-13C overrides TB-13A.

14.2.5 ANALOG OUTPUT SIGNALS

There are two terminals that can supply analog output signals proportional to output frequency and load. Terminal TB-10A can provide a 0-10 VDC or a 2-10 VDC signal proportional to output frequency, and TB-10B can provide the same signals proportional to load. The 2-10 VDC signals can be converted to a 4-20 mA signal using a resistor in series with the signal such that the total circuit resistance is 500 Ohms. See Parameters: 42 - TB10A OUTPUT, 43 - TB10A SCALING, 44 - TB10B OUTPUT, and 45 - TB10B SCALING in Section 18.0 - DESCRIPTION OF PARAMETERS.

14.2.6 DRIVE STATUS OUTPUTS

The control board has one Form C relay at terminals TB-16, TB-17, and TB-18. Contacts are rated 2 amps at 28 VDC or 120 Vac.

There are also two open-collector outputs at terminals TB-14 and TB-15. The open-collector circuit is a current-sinking type rated at 30 VDC and 40 mA maximum. A power supply (30 VDC max) must be used to power the open-collector outputs. The standard drive does not have a power supply (a 24 VDC power supply is optional when the drive is equipped with the Bypass option).

The Form C relay and open-collector outputs can be programmed for many different status indications. See Parameters 52 - TB14/RELAY #2, 53 - TB15/RELAY #3, and 54 - RELAY #1.

NOTE: The Bypass option includes two Form C relays and a third is optional (refer to Appendix A). When the drive is equipped with the Option Box, there are two Form C relays and two open-collector outputs (refer to Appendix B).

15.0 MCH CONTROL WIRING DIAGRAMS

The following wiring diagrams apply to standard MCH drives. Refer to Appendix A for control wiring for the Bypass option, or Appendix B for control wiring for the Option Box.

15.1 MCH TERMINAL STRIP

Shown below is the terminal strip on the main control board, along with a brief description of the function of each terminal.

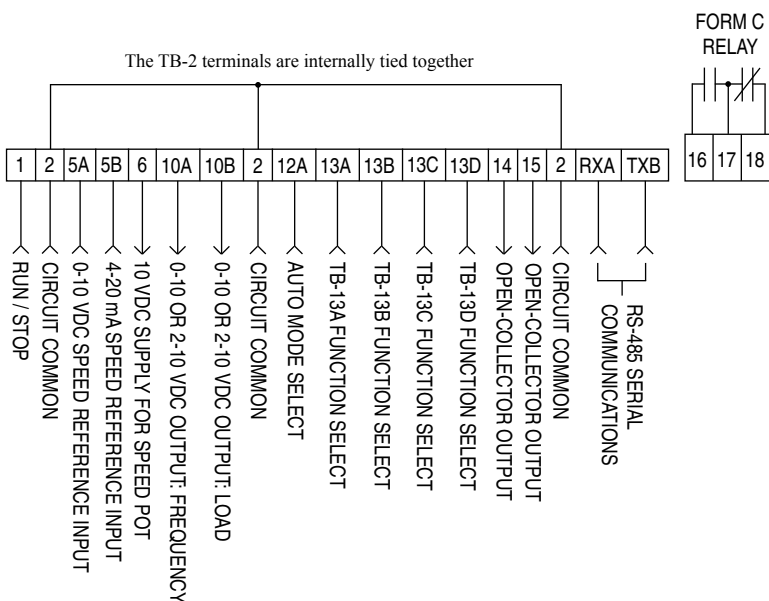

NOTE: The function of terminals TB-10A, TB-10B, TB-13A, TB-13B, TB-13C, TB-13D, TB-14, TB-15, TB-16, and TB-18 are dependent on the programming of certain parameters. In most cases, the name of the parameter matches the number of the terminal, allowing quick and easy programming of the terminals to suit the application. The exception is TB-16 and TB-18, which are governed by Parameter 54 - RELAY.

A complete description of operating the drive in the AUTO mode can be found in Section 14.2. The following diagrams provide a quick reference to wire the drive for the most common configurations.

15.2 KEYPAD H/O/A

When the drive is in Keypad H/O/A mode, the AUTO (START) key on the keypad is used to put the drive into AUTO mode. The drive will then respond to start/stop commands from the terminal strip. The start/stop circuit is wired as shown below. Also shown is the wiring for a 4-20 mA or 0-10 VDC speed reference signal.

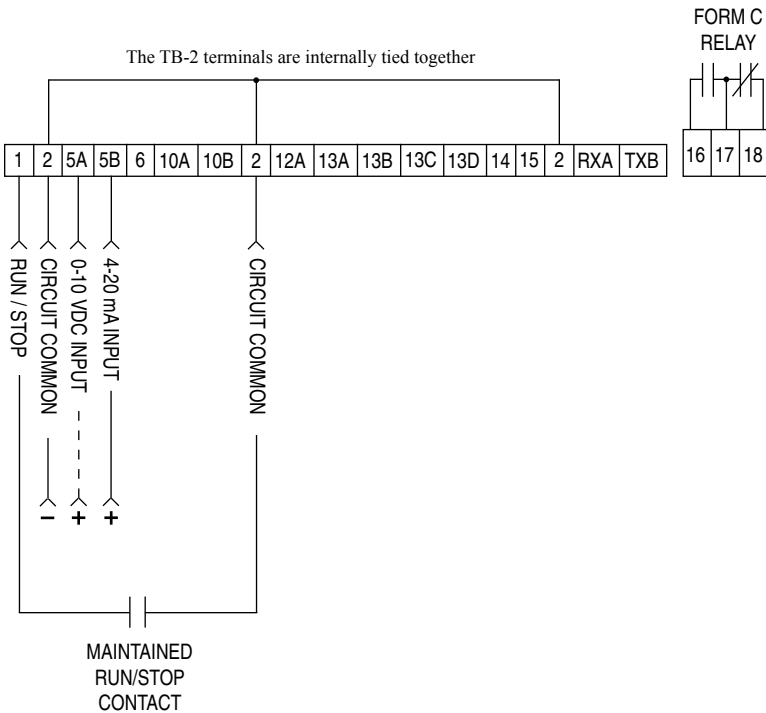

NOTES:

1. Close TB-1 to TB-2 to RUN, and open to STOP.
2. When the drive is put into AUTO mode, the speed reference will be determined by AUTO SOURCE (Parameter 24). In the example above, the AUTO speed reference is either a 4-20 mA or 0-10 VDC signal.
3. When HAND mode is selected, the drive starts immediately. TB-1 has no effect.

15.3 REMOTE H/O/A

Shown below is the wiring diagram for selecting H/O/A from the terminal strip. Also shown is the wiring for a 0-10 VDC or 4-20 mA speed reference signal. In HAND mode, TB-1 must be closed to TB-2 in order to start the drive. In AUTO mode, close TB-1 to TB-2 to RUN, and open to STOP

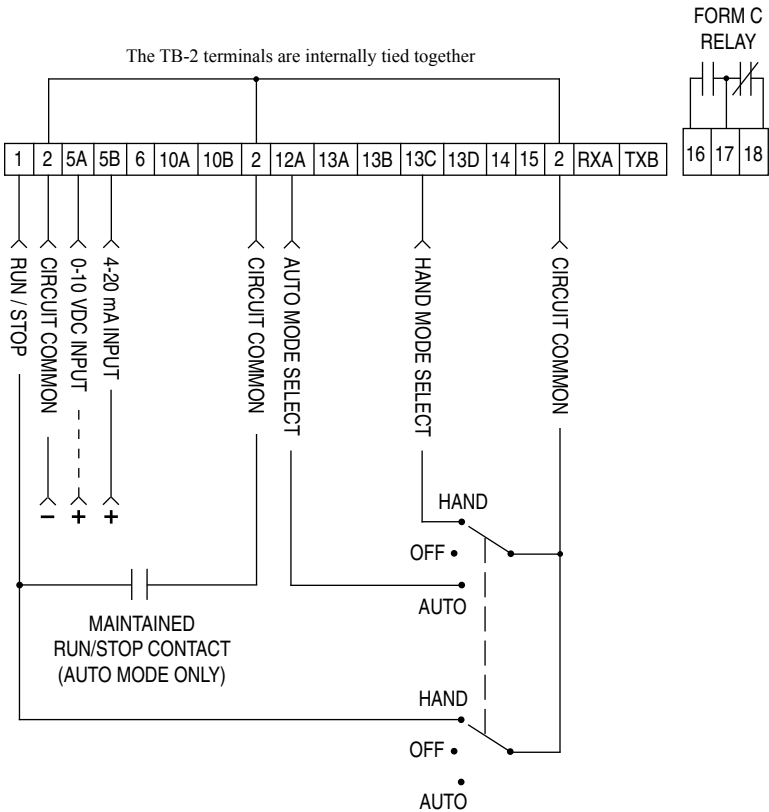

NOTES:

1. Program TB-13C (Parameter 49) to HAND. This forces TB-12A to act as AUTO.
2. In AUTO mode (TB-12A closed to TB-2), close TB-1 to TB-2 to RUN, and open to STOP. The speed reference will be determined by AUTO SOURCE (Parameter 24).
3. When HAND mode is selected (TB-13C closed to TB-2), TB-1 must also be closed to TB-2 in order to RUN. The speed reference will be determined by HAND SOURCE (Parameter 29).

15.4 SPEED POT AND PRESET SPEED CONTROL

In this example, the drive is in Keypad H/O/A mode. In HAND mode, speed is controlled from the speed pot. In AUTO mode, speed is controlled by the selected PRESET SPEED.

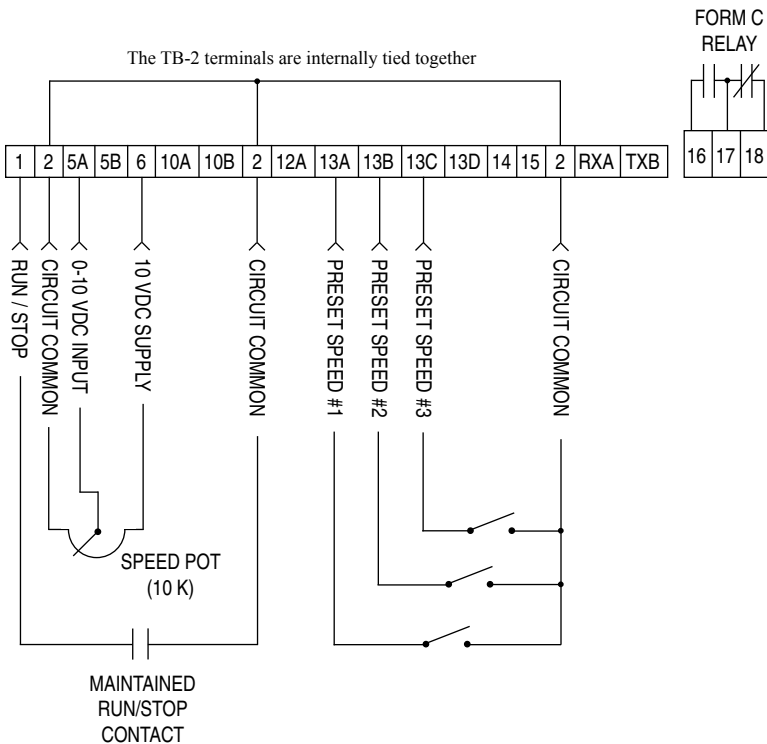

NOTES:

1. Program the PRESETS (Parameters 1-4) to the desired values.
2. Program TB-13A to PRESET #1, TB-13B to PRESET #2, and TB-13C to PRESET #3 (Parameters 47-49). Close any two to select PRESET #4.
3. Program HAND SOURCE (Parameter 29) to 0-10 VDC. In HAND mode, the speed will be controlled by the speed pot.
4. Program AUTO SOURCE (Parameter 24) to SELECTED. In AUTO mode, the speed will be controlled by the preset speeds.

16.0 PROGRAMMING THE MCH DRIVE

The MCH keypad serves two purposes: operating the drive when in the LOCAL mode, and programming the parameters for particular applications. The keypad is shown below, along with the display that should appear when the drive is first powered up:

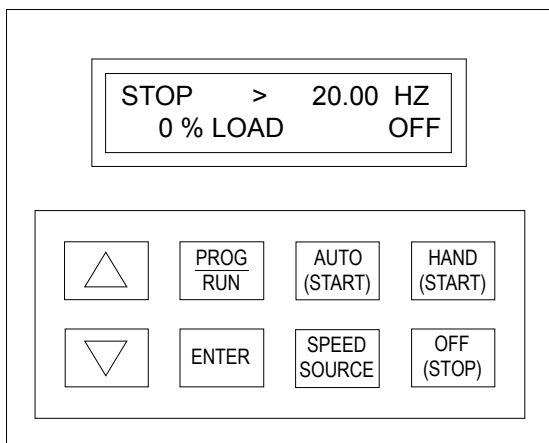

To program the drive, the PROGRAM mode must be entered by pressing the PROG/RUN button. If the password protection is disabled, pressing the PROG/RUN button will result in direct entry into the PROGRAM mode. If the password protection is enabled, the PASSWORD prompt will appear when an attempt is made to enter the PROGRAM mode. The PASSWORD prompt appears as follows:

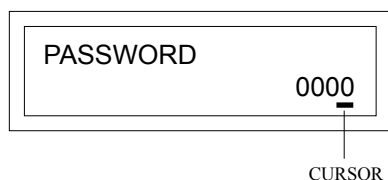

To enter the password, use the ▲ and ▼ keys to scroll to the password value, and then press the ENTER key.

NOTE: The factory default password is 0019.

Once the correct password is entered, the PROGRAM mode will be entered and the first parameter will be displayed, which is Parameter 0 - LINE VOLTS. This is shown below:

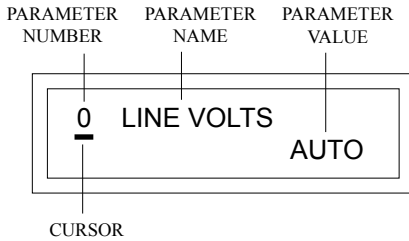

To scroll through the parameters, use the ▲ and ▼ keys on the keypad. When the desired parameter is found, press the ENTER key to shift the cursor from the parameter name to the parameter value. In this example, the cursor shifts from LINE VOLTS to AUTO:

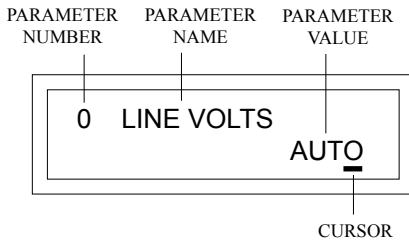

The parameter value can then be changed using the ▲ and ▼ keys. If the parameter has a numerical value, the ▲ key will increase the value and the ▼ key will decrease the value. If the parameter has specific choices that can be selected, the ▲ and ▼ keys will scroll through the list of possible settings. When the desired value or option is selected, press the ENTER key to store the new setting. If the new setting is not ENTERED, it will not take effect and the old setting will still be valid.

If the PROG/RUN key is pushed while the cursor is highlighting the parameter value, the value will change back to the original setting (if it had been changed, but not ENTERED), and the cursor will shift back to the parameter name. Pressing PROG/RUN again will exit the PROGRAM mode. If the PROGRAM mode is entered again within two minutes, the last parameter that was viewed, or changed, will come up on the display. After two minutes has elapsed, the password will have to be entered again when attempting to access the PROGRAM mode.

17.0 PARAMETER MENU

PARAMETER MENU			
PARAM. NUMBER	PARAMETER NAME	RANGE OF ADJUSTMENT	FACTORY DEFAULT
0	LINE VOLTS	HIGH, LOW, AUTO	AUTO
1	PRESET #1	(NOTE 1)	20.00 Hz
2	PRESET #2	(NOTE 1)	20.00 Hz
3	PRESET #3	(NOTE 1)	20.00 Hz
4	PRESET #4	(NOTE 1)	20.00 Hz
5	SKIP FREQ #1	.00 Hz - MAXIMUM FREQ	.00 Hz
6	SKIP FREQ #2	.00 Hz - MAXIMUM FREQ	.00 Hz
7	BANDWIDTH	.00 - 10.00 Hz	1.00 Hz
8	ACCEL RATE	(NOTE 1)	30.0 SEC
9	DECEL RATE	(NOTE 1)	30.0 SEC
10	MINIMUM FREQ	.00 - MAXIMUM FREQ	.50 Hz
11	MAXIMUM FREQ	MINIMUM FREQ - 120.0 Hz	60.00 Hz
12	DC BRAKE VOLT	(NOTE 1)	.0 VDC
13	DC BRAKE TIME	.0 - 999.9 SEC	.0 SEC
14	DYNAMIC BRAKE	OFF, ON	OFF
16	CURRENT LIMIT	25 - 120 %	120 %
17	MOTOR OVRLOAD	25 - 100 %	100%
18	BASE FREQ	20.00 - 360.0 Hz	60.00 Hz
19	FIXED BOOST	.0 - 30.0 %	(NOTE 1)
22	TORQUE	CONSTANT, VARIABLE, CONST / NO COMP	CONSTANT
23	CARRIER FREQ	2.5, 6, 8, 10, 12, 14 kHz	2.5 kHz

NOTE 1: REFER TO SECTION 18.0 - DESCRIPTION OF PARAMETERS.

PARAMETER MENU			
PARAM. NUMBER	PARAMETER NAME	RANGE OF ADJUSTMENT	FACTORY DEFAULT
24	AUTO SOURCE	KEYPAD, 0-10 VDC, 4-20 MA, PRESET #1, PRESET #2, PRESET #3, PRESET #4, MOP, SELECTED	4-20 MA
25	START METHOD	NORMAL, POWER UP, AUTO 1, AUTO 2, AUTO 3	NORMAL
26	STOP METHOD	RAMP, COAST	COAST
28	SPEED SRC KEY	ENABLED, DISABLED	ENABLED
29	HAND SOURCE	KEYPAD, 0-10 VDC, 4-20 MA, PRESET #1, PRESET #2, PRESET #3, PRESET #4, MOP, SELECTED	KEYPAD
30	CONTROL	NORMAL, NORM NO HAND, SERIAL SPEED, S SPD/NO HAND, SERIAL AUTO, S AUTO/NO HND	NORMAL
31	UNITS	speed: HERTZ, RPM, % HZ, /SEC, /MIN, /HR, GPH, NONE pid: %, PSI, FPM, CFM, GPM, IN, FT, /SEC, /MIN, /HR, F, C, MPM, GPH	speed: HERTZ
32	HZ MULTIPLIER	.10 - 650.0	1.00
33	UNITS DECIMAL	XXXXX, XXX.X, XX.XX, X.XXX, .XXXX	XXXXX
34	LOAD MULTIPLY	95 - 139 %	100%
35	LCD CONTRAST	LOW, MED, HIGH	MED
36	SLEEP THRSHLD	.00 - 360.0 Hz	.00 Hz
37	SLEEP DELAY	.0 - 300 SEC	30.0 SEC
38	SLEEP BANDWID	FB @ MIN - FB @ MAX	0%
39	TB5 MIN FREQ	.00 - 360.0 Hz	.00 Hz
40	TB5 MAX FREQ	.00 - 360.0 Hz	60.00 Hz
41	AN INPUT FLTR	0.01 - 10.0 SEC	0.02 SEC
42	TB10A OUTPUT	NONE, 0-10V, 2-10V	NONE

PARAMETER MENU			
PARAM. NUMBER	PARAMETER NAME	RANGE OF ADJUSTMENT	FACTORY DEFAULT
43	TB10A SCALING	3.00 - 360.0 Hz	60.00 Hz
44	TB10B OUTPUT	NONE, 0-10V, 2-10V	NONE
45	TB10B SCALING	10 - 200 %	125 %
47	TB13A INPUT	NONE, 0-10VDC, 4-20MA, PRESET #1, DECREASE FREQ, REVERSE	NONE
48	TB13B INPUT	NONE, 0-10VDC, 4-20MA, PRESET #2, INCREASE FREQ	NONE
49	TB13C INPUT	NONE, 0-10VDC, 4-20MA, PRESET #3, HAND, REVERSE	NONE
50	TB13D INPUT	EXTERN FAULT, EXTERN /FAULT, EXTERN CLEAR	EXTERN FAULT
52 53 54	TB14/RELAY #2 TB15/RELAY #3 RELAY #1	NONE, RUN, FAULT, INVERSE FAULT, FAULT LOCKOUT, AT SPEED, ABOVE PRSET #3, CURRENT LIMIT, AUTO/HAND SRC, FOLLOWER PRES, MIN/MAX ALARM, INV MIN/MAX A, MIN ALARM, INV MIN ALARM, MAX ALARM, INV MAX ALARM, RUN REVERSE	NONE
55	TB5B LOSS	FAULT, PRESET #3	FAULT
56	SERIAL LOSS	FAULT, AUTO	FAULT
57	SERIAL	DISABLED, WITH TIMER, W/O TIMER	DISABLED
58	SERIAL ADDRES	1 - 247	30
61	PASSWORD	0000 - 9999	0019
63	SOFTWARE VERS	(VIEW - ONLY)	(N/A)
64	MONITOR MODE	OFF, ON	ON

PARAMETER MENU			
PARAM. NUMBER	PARAMETER NAME	RANGE OF ADJUSTMENT	FACTORY DEFAULT
65	PROGRAM	MAINTAIN, RESET 60, RESET 50	RESET 60
66	CLEAR HISTORY	MAINTAIN, CLEAR	MAINTAIN
70	PID MODE	OFF, NORMAL, REVERSE	OFF
74	PID FEEDBACK	TB-5A, TB-5B	TB-5A
75	FEEDBACK @ MIN	-32500 to 32500	0.0%
76	FEEDBACK @ MAX	-32500 to 32500	100.0%
77	PROPOR. GAIN	0.0 - 999.9%	5.00%
78	INTEGRAL GAIN	0.0 - 10.0 SEC	0.0 SEC
79	DIFF. GAIN	0.0 - 10.0 SEC	0.0 SEC
80	PID ACCEL	0.0 - 100.0 SEC	30.0 SEC
81	MIN ALARM	FB @ MIN - FB @ MAX	0.0%
82	MAX ALARM	FB @ MIN - FB @ MAX	0.0%
98	LANGUAGE	(NOTE 1)	ENGLISH
99	FAULT HISTORY	(VIEW - ONLY)	(N/A)

NOTE 1: REFER TO SECTION 18.0 - DESCRIPTION OF PARAMETERS.

18.0 DESCRIPTION OF PARAMETERS

0 LINE VOLTS

This parameter calibrates the drive based on the input voltage, and can be set to AUTO, HIGH, or LOW. When set to AUTO, the drive automatically selects HIGH or LOW based on the incoming voltage.

This parameter can also be set “manually”, using the HIGH or LOW settings. Refer to the table below:

INPUT LINE VOLTAGE SELECTION				
MODEL	RATED INPUT VOLTAGE	INPUT PHASE	ACTUAL INPUT VOLTAGE	PARAM. SETTING
MH200	240 / 200 Vac	3	220 - 240 Vac	HIGH
	240 / 200 Vac	3	200 - 208 Vac	LOW
MH400	480 / 400 Vac	3	460 - 480 Vac	HIGH
	480 / 400 Vac	3	380 - 415 Vac	LOW
MH500	590 / 480 Vac	3	575 - 600 Vac	HIGH
	590 / 480 Vac	3	460 - 480 Vac	LOW

1-4 PRESET #1- #4

PRESETS are activated via contact closures between terminal TB-2 and terminals TB-13A, TB-13B, and TB-13C. These terminals must be programmed as preset selects using Parameters 47 - 49: TB13A INPUT, TB13B INPUT, and TB13C INPUT.

In non-PID mode, PRESETS #1-#4 can be used as preset speeds. In this case, the PRESETS are set in Hz, and can only be set to values within the range defined by the minimum and maximum frequency (Parameters 10 and 11).

In PID mode, PRESETS #1, #2, and #4 can also be used as preset setpoints (PRESET #3 cannot be used as a preset setpoint, only a preset speed). In this case, PRESETS #1, #2, and #4 are set in actual PID units (the units selected in Parameter 31 - UNITS), and can only be set to values within the range defined by the minimum and maximum PID feedback (Parameters 75 and 76).

The following table shows how each preset is selected using the TB-13 terminals. OPEN and CLOSED refer to the state of the TB-13 terminal relative to TB-2.

PRESET ACTIVATION			
PRESET #	TB - 13A	TB - 13B	TB - 13C
1	CLOSED	OPEN	OPEN
2	OPEN	CLOSED	OPEN
3	OPEN	OPEN	CLOSED
4	CLOSED	CLOSED	OPEN
	CLOSED	OPEN	CLOSED
	OPEN	CLOSED	CLOSED

5,6 **SKIP FREQ #1 & #2**
7 **BANDWIDTH**

These parameters are used to prevent the drive from operating continuously at critical frequencies that cause excessive mechanical vibration of the driven equipment. The SKIP FREQUENCIES (Parameters 5 and 6) and the SKIP BANDWIDTH (Parameter 7) are used to define up to two speed avoidance ranges. The SKIP FREQUENCY settings define the starting point of the speed range that is to be avoided, and the SKIP BANDWIDTH setting defines how far the speed range extends beyond SKIP FREQUENCY. Setting the SKIP FREQUENCIES to .00 Hz disables this function.

Example: The critical frequency is 21 Hz, and a bandwidth of 2 Hz is desired. Therefore, set SKIP FREQ #1 to 20 Hz and set SKIP BANDWIDTH to 2 Hz. This results in a speed range from 20 Hz to 22 Hz that the drive will not operate within continuously. If the drive were operating at 25 Hz and then commanded to operate at a speed within the range of avoidance, the drive would decelerate to 22 Hz and remain at that frequency until commanded to 20 Hz or below. The drive would then decelerate through the range of avoidance to the new frequency. Likewise, if the drive were operating at 18 Hz, and then commanded to operate at a speed within the range of avoidance, the drive would accelerate to 20 Hz and remain at that frequency until commanded to a speed of 22 Hz or above. The drive would then accelerate through the range of avoidance to the new frequency.

8 **ACCEL RATE**

ACCEL RATE sets the acceleration time for all speed reference sources (keypad, speed pot, 4-20 mA, 0-10 VDC, and preset speeds). The ACCEL RATE setting is the time to accelerate from 0 Hz to the BASE FREQUENCY (Parameter 18). The range of adjustment depends on horsepower. Refer to the table below:

ACCELERATION LIMITS	
HORSEPOWER	RANGE OF ADJUSTMENT
0.25 - 20	0.1 - 3600 SEC
25 - 60	0.3 - 3600 SEC
75 - 250	0.6 - 3600 SEC

Example: If ACCEL RATE is set to 30 seconds, and the BASE FREQUENCY is set to 60 Hz, the drive will ramp from 0 Hz to 60 Hz in 30 seconds. This is a linear function, therefore the drive would ramp up to 30 Hz in 15 seconds, etc.

NOTE: The ability to accelerate a given load at a particular rate is limited by the output power capability of the drive/motor combination. The acceleration of high-inertia and high-friction loads may be affected by the current limiting characteristics of the drive. See Parameters 16 - CURRENT LIMIT and 19 - FIXED BOOST for more information.

9 DECEL RATE

DECEL RATE sets the deceleration time for all speed reference sources. The DECEL setting is the time to decelerate from BASE FREQUENCY to 0 Hz. As with Parameter 8 - ACCEL RATE, this is a linear function. If the drive is set to coast to a stop, DECEL will have no effect when a STOP command is given. The range of adjustment for DECEL depends on horsepower, voltage, and whether Dynamic Braking (DB) is being used. Refer to the table below:

DECELERATION LIMITS				
HORSEPOWER / VOLTAGE RATING			RANGE OF ADJUSTMENT	
240 / 200 Vac (NOTE 1)	480 / 400 Vac	590 / 480 Vac	WITHOUT DB (NOTE 2)	WITH DB
0.25 - 7.5 HP	1 - 7.5 HP	----	0.3 - 3600 SEC	0.1 - 3600 SEC
10 - 15 HP	10 - 20 HP	1 - 7.5 HP	0.5 - 3600 SEC	0.1 - 3600 SEC
20 - 60 HP	25 - 60 HP	10 - 20 HP	1.0 - 3600 SEC	0.2 - 3600 SEC
----	75 - 100 HP	25 - 60 HP	2.0 - 3600 SEC	0.2 - 3600 SEC
----	125 - 250 HP	75 - 200 HP	4.0 - 3600 SEC	0.2 - 3600 SEC

NOTE 1: 240/120 Vac units have the same limits as 240/200 Vac units.

NOTE 2: This parameter can be set as low as the value shown in the WITH DB column. However, the value shown in the WITHOUT DB column is the operational limit of a drive without dynamic braking. For example, DECEL can be set as low as 0.1 seconds on a 10 HP, 480 Vac drive without dynamic braking, but the actual minimum deceleration time would be 0.5 seconds.

If an attempt is made to decelerate a high-inertia load too quickly, the motor will regenerate voltage back into the drive. This will cause the DC bus voltage to rise, which can result in a HI VOLTS fault. In order to prevent faulting, the drive will enter DECEL FREEZE, which halts the deceleration until the DC bus voltage returns to a normal level. The drive will then begin to decelerate again, and if necessary, will enter DECEL FREEZE repeatedly to avoid faulting. If a very short deceleration time is programmed, DECEL FREEZE may not be able to compensate fast enough, resulting in a HI VOLTS fault.

In applications where very short deceleration times are required on high-inertia loads, dynamic braking may be required. Consult the factory for more information on the Dynamic Braking option.

10 MINIMUM FREQ

This parameter defines the lower limit of the drive's speed range. MINIMUM FREQ is used in conjunction with MAXIMUM FREQ (Parameter 11 below) to define the operating range of the drive.

If MINIMUM FREQ is set to a value above 0.0 Hz, the drive will ramp up from 0.0 Hz when given a start command. Once running, however, the drive will not operate below the MINIMUM FREQ setting unless the rotation is changed, or a stop command is issued and the drive is programmed to ramp to a stop.

If MINIMUM FREQ is set to 0.0 Hz, the drive may be operated in ZERO SPEED mode (drive is in RUN state, but there is no output to the motor). ZERO SPEED operation can be used in applications requiring the ability to start and stop the drive using only the selected speed reference. The drive will start when the speed reference is raised above 0 VDC or 4 mA, and it will stop when the reference is lowered to 0 VDC or 4 mA. Note that the drive must be initially started using one of the normal start commands (keypad or terminal strip).

11 MAXIMUM FREQ

This parameter defines the upper limit of the drive's speed range. MAXIMUM FREQ is used in conjunction with MINIMUM FREQ (Parameter 10 above) to define the operating range of the drive.

WARNING!

Consult motor manufacturer before operating motor above rated frequency. Overspeeding the motor and/or driven equipment can cause damage to equipment and injury to personnel!

12 DC BRAKE VOLT

DC braking creates a braking torque by injecting DC voltage into the motor. This parameter sets the magnitude of that DC voltage.

The point at which the drive applies DC braking to the motor depends on which STOP method is programmed (either COAST or RAMP, see Parameter 26 - STOP METHOD).

If the drive is set to COAST, DC braking is activated when the stop command is given. In this case, DC braking helps decelerate the motor. This is useful in applications where a quick deceleration is desired on a load that would normally take a long time to coast to a stop.

If the drive is set to RAMP, DC braking is activated when the output frequency reaches 0 Hz. In this case, the drive decelerates the load to a near stop and then DC braking is used to stop and hold the motor. This is useful in applications where the load needs to be stopped in a certain position. Similar applications with high-inertia loads utilize both dynamic braking and DC braking. The dynamic braking allows the high-inertia load to be decelerated quickly, while the DC braking stops the load in the desired position.

Due to heat generated in the motor, DC braking should only be used in applications where the load is stopped infrequently. In high duty-cycle applications, dynamic braking is recommended because the heat is dissipated through external resistor banks, rather than in the motor. When used, DC BRAKE VOLT should be set to the lowest voltage that provides satisfactory operation in order to minimize motor heating. The maximum voltage available depends on the voltage rating of the drive. Refer to the table below:

MAXIMUM DC BRAKE VOLTAGE		
MODEL MH200 240 / 200 Vac	MODEL MH400 480 / 400 Vac	MODEL MH500 590 / 480 Vac
24 VOLTS	48 VOLTS	59 VOLTS

13 DC BRAKE TIME

This parameter determines the length of time that the DC braking voltage is applied to the motor. DC BRAKE TIME should be set to the lowest value that provides satisfactory operation in order to minimize motor heating.

NOTE: If this parameter is set to 999.9 seconds (the maximum value), the DC braking will be continuous. If it is set to .0 seconds, it is disabled.

14 DYNAMIC BRAKE

This parameter enables the dynamic braking circuit. Set this parameter to ON only if the optional dynamic braking circuit board and resistors are installed.

Dynamic braking is used in applications where high-inertia loads need to be decelerated quickly. When this is attempted, the motor regenerates voltage back into the drive, causing the DC bus voltage to rise, eventually resulting in a HI VOLTS fault. With the dynamic braking option, the DC bus voltage is monitored, and when it reaches a certain level, a transistor is switched on that connects an external resistor bank across the DC bus. This allows the regenerated energy from the motor to be dissipated through the resistors as heat, which keeps the DC bus voltage below the trip level.

16 CURRENT LIMIT

This parameter sets the maximum allowable output current of the drive, which also determines the torque capability of the motor. For most applications, CURRENT LIMIT is left at the maximum setting, which is 120% of the drive's output current rating. Regardless of the CURRENT LIMIT setting, the drive is capable of delivering a maximum of 120% current for one minute before tripping into an OVERLOAD fault. See Parameter 17 – MOTOR OVRLOAD below.

The drive will enter current limit when the load demands more current than the drive can deliver, which results in a loss of synchronization between the drive and the motor. To correct this condition, the drive will enter FREQUENCY FOLDBACK, which commands the drive to decelerate in order to reduce the output current and regain synchronization with the motor. When the overcurrent condition passes, the drive will return to normal operation and accelerate back to the speed setpoint. However, if FREQUENCY FOLDBACK cannot correct the condition and the drive remains in current limit for too long, it will trip on an OVERLOAD fault. If the drive enters current limit while accelerating, the time required to reach the speed setpoint will be longer than the time programmed into ACCEL RATE (Parameter 8).

17 MOTOR OVRLOAD

The MCH Series is UL approved for solid state motor overload protection. Therefore, a separate thermal overload relay is not required for single motor applications. The MOTOR OVERLOAD circuit is used to protect the motor from overheating due to excessive current draw.

The trip time for the MOTOR OVERLOAD setting is based on what is known as an “inverse I^2t ” function. This function allows the drive to deliver 120% of the rated output current for one minute, and even higher current levels for shorter periods of time. Once the overload circuit “times out”, the drive will trip into an OVERLOAD fault.

The MOTOR OVERLOAD should be set to a value which is equal to the ratio (in percentage) of the motor full load current rating to the drive output current rating. This will result in an overload capacity of 120% of the MOTOR current rating for one minute. If this parameter is set to 100%, the motor will be allowed to draw 120% of the DRIVE output current rating for one minute. This distinction is important in cases where the motor full load current rating is significantly less than the drive output current rating, such as applications where the drive is oversized to meet torque requirements.

Example 1: A 5 Hp, 480 Vac drive is operating a 3 HP motor with a full load current rating of 4.8 amps. Divide the motor current rating by the drive output current rating: $4.8 / 7.6 = 63\%$. Entering this value will allow continuous operation at 4.8 amps, and will also allow the motor to draw 5.8 amps (120% of 4.8 amps) for one minute. If the setting is left at 100%, the motor could draw 9.1 amps (120% of 7.6 amps) for one minute before faulting.

The MCH Series drive has two options for thermal overload protection. One depends on the speed of the drive, while the other does not. The diagram below illustrates the difference between “speed compensated” and “non-compensated” thermal overload protection.

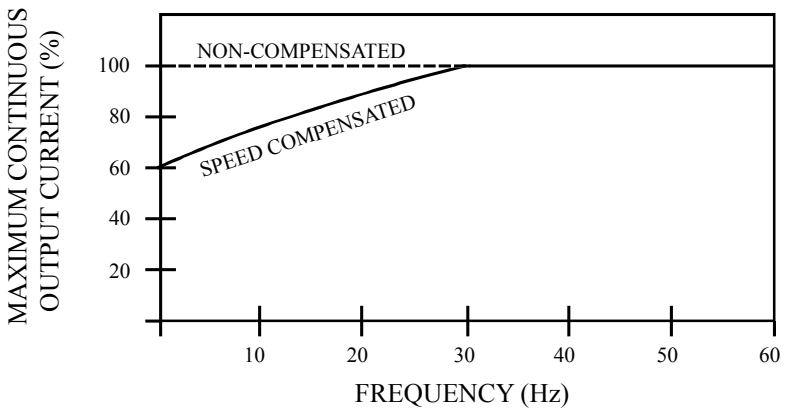

The “speed-compensated” thermal overload circuit offers additional protection from high load conditions at low speeds, where motor cooling is often less effective (e.g., motors with shaft-mounted fans). As seen on the diagram below, the drive reduces the allowable continuous output current when operating at frequencies less than 30 Hz.

Example 2: A 480 Vac, 20 HP drive is operating a motor at 10 Hz. From the diagram, a drive operating at 10 Hz can deliver about 75% of its output current rating continuously. A 480 Vac, 20 HP drive’s output current rating is 27 Amps. Therefore, the drive would be able to operate continuously at 20 Amps. The drive would also be able to deliver 120% of that value (24 Amps) for one minute before tripping into an OVERLOAD fault.

The “speed compensated” thermal overload is the factory default and should be used in applications where the motor does not normally experience high loads at low speeds for extended periods of time.

NOTE 1: The above diagram is based on a MOTOR OVRLOAD setting of 100%. For lower MOTOR OVRLOAD settings, reduce the % CURRENT values by the same percentage. For example, if MOTOR OVRLOAD is set to 75%, reduce the % CURRENT values by 25%. Therefore, the curve shifts down, but the shape of the curve remains the same.

The “non-compensated” thermal overload circuit allows 100% current continuously, and 120% current for one minute, at all speeds. In the example above, the motor operating at 10 Hz without “speed-compensated” protection would be allowed to operate continuously at 27 Amps, and could draw 32.4 Amps for one minute before tripping. Without sufficient motor cooling, this can result in motor failure due to overheating.

The “non-compensated” circuit is selected by setting Parameter 22 - TORQUE to CONST / NO COMP. The “non-compensated” setting should only be used in applications where the motor is properly cooled at all speeds, or the motor manufacturer has approved the motor for full-load operation at low speeds.

NOTE 2: The operation of the motor thermal overload circuit is affected by the setting of Parameter 34 - LOAD MULTIPLY.

18 BASE FREQ

The BASE FREQUENCY determines the V/Hz ratio by setting the frequency at which the drive will output full voltage to the motor. For most applications the base frequency should be set to match the motor’s rated frequency.

For example, if the drive is rated for 460 Vac output, and the BASE FREQUENCY is set to 60 Hz, the drive will maintain a constant ratio of 7.66 V/Hz (except when FIXED BOOST is active, see Parameter 19) from 0 Hz to 60 Hz. This range is the region of constant torque. If the motor speed is increased past 60 Hz, the output voltage remains constant while the frequency increases, resulting in a reduced V/Hz ratio. This range, from 60 Hz to about 90 Hz, is the region of constant horsepower. Above 90 Hz, horsepower begins to decrease as frequency increases. Refer to Section 6.1 - DESCRIPTION OF AC MOTOR OPERATION.

19 FIXED BOOST

This parameter is used in applications which require high starting torque. FIXED BOOST increases the output voltage at lower output frequencies (below 30 Hz for 60 Hz base frequency), in order to boost the torque capability of the motor. Refer to the diagram below. The factory default for FIXED BOOST depends on the horsepower rating of the drive. Refer to the table below:

FX BOOST FACTORY DEFAULT SETTINGS			
HP	FACTORY DEFAULT	HP	FACTORY DEFAULT
0.25 - 1	5.30 %	20	2.00 %
1.5 - 2	4.40 %	25	1.80 %
3	3.60 %	30	1.60 %
5	3.00 %	40	1.20 %
7.5	2.70 %	50 - 75	0.80 %
10	2.40 %	100 - 125	0.60 %
15	2.20 %	150 - 250	0.40 %

The diagram below illustrates how FIXED BOOST alters the V/Hz ratio to increase motor torque.

The FIXED BOOST setting represents the amount of boost at 0 Hz (approximately 15% in the example below), and as the output frequency approaches 30 Hz, the boost decreases to zero. Therefore, at 30 Hz and above, the V/Hz ratio returns to its “normal” state.

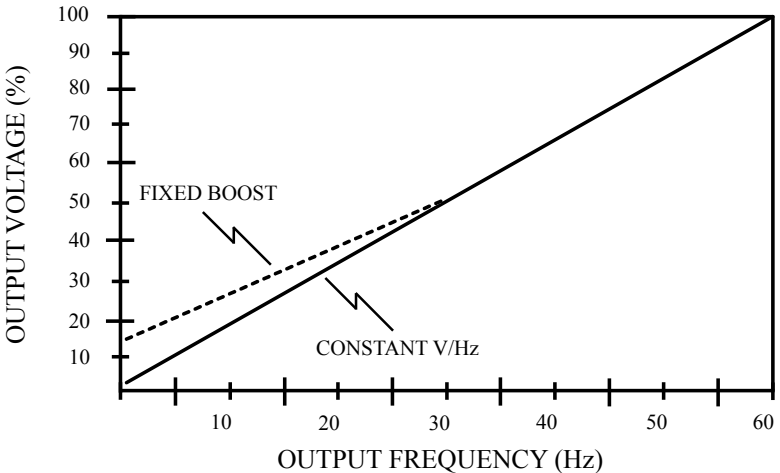

22 TORQUE

(TORQUE CURVE SELECTION)

This parameter is used to select whether the output of the drive follows a constant or variable V/Hz curve. The following selections are available:

CONSTANT

Use for constant torque applications to optimize torque.

VARIABLE	Use for variable torque applications to optimize energy savings.
CONST / NO COMP	Use for constant torque applications that require full overload capacity at low speeds (see Parameter 17 - MOTOR OL).

23 CARRIER FREQ

This parameter sets the carrier frequency, or switching frequency of the output IGBT's. Higher switching rates result in less audible noise to be emitted from the motor, but the efficiency of the drive decreases as the carrier frequency increases. Therefore, this parameter should be set to the lowest value which yields acceptable sound levels. Available settings are: 2.5 kHz, 6 kHz, 8 kHz, 10 kHz, 12 kHz and 14 kHz.

NOTE 1: The 2.5 kHz carrier frequency setting is a variable carrier. The carrier frequency remains fixed at 1.5 kHz up to 25 Hz output frequency. Above 25 Hz, the carrier is a fixed multiple of 60 times the drive's output frequency. For example, if the output frequency of the drive was set to 45 Hz, the carrier frequency would be 2.7 kHz (45 Hz x 60 = 2700 Hz). The other settings are constant carriers that remain fixed for the entire speed range.

NOTE 2: The ability to operate a drive at higher carrier frequencies is dependent on the drive horsepower rating, driven load, drive enclosure, and the ambient temperature. Operation above 8kHz requires derating the drive by multiplying the output current rating by the following factors: 0.94 at 10 kHz, 0.89 at 12 kHz, and 0.83 at 14 kHz.

24 AUTO SOURCE

This parameter selects the speed reference source that the drive will follow when it is in AUTO mode. The following options are possible:

KEYPAD	The ▲ and ▼ keys control the drive speed.
0-10 VDC	The drive will follow a 0-10 VDC signal wired between TB-5A (+) and TB-2 (-).
4-20 MA	The drive will follow a 4-20 mA signal wired between TB-5B (+) and TB-2 (-).
PRESET #1 - #4	The drive will run at a programmable preset speed. Refer to Parameters 1-4.

- MOP** The drive speed is controlled by two contacts (one to increase the speed and the other to decrease the speed). Program TB-13A (Parameter 47) to DECREASE FREQ, and TB-13B (Parameter 48) to INCREASE FREQ. Closing TB-13A to TB-2 will decrease the speed, and closing TB-13B to TB-2 will increase the speed. Refer to Section 14.2.4.
- SELECTED** The drive speed will be determined by whatever speed reference is selected using the TB-13 terminals. Refer to Parameters 47, 48, and 49.

25 START METHOD

WARNING!

Automatic start of equipment may result in damage to equipment and/or injury to personnel! Automatic start should only be used on equipment that is inaccessible to personnel.

This parameter selects the starting method for the drive, and can be set for one of the following:

- NORMAL** The drive will start when the appropriate contact closure is made on the terminal strip (in REMOTE mode), or by pressing the keypad START key (in LOCAL mode). To start the drive in NORMAL mode, a start command must be issued at least two seconds AFTER input power is applied.
- POWER UP** The drive will automatically start upon application of input power. The drive **MUST** be in AUTO mode, and the start command **MUST** be present when power is applied for this function to operate.
- AUTO 1** FLYING AUTO RESTART - LOW performance. Synchronization in approximately 6 seconds with current levels up to 50% of the drive rating. This setting results in a slow, smooth synchronization.
- AUTO 2** FLYING AUTO RESTART - MEDIUM performance. Synchronization in approximately 1 second with current levels up to 50% of the drive rating. This setting allows faster synchronization while retaining smoothness.
- AUTO 3** FLYING AUTO RESTART - HIGH performance. Synchronization in approximately 1 second with current levels up to 100% of the drive rating. This setting allows the fastest synchronization, but sacrifices smoothness.

The AUTO 1 - 3 settings allow the drive to start into a spinning load after a fault or upon application of input power. As with POWER UP, the drive MUST be in AUTO mode, and the start command MUST be present after a fault or when power is applied for this function to operate.

When set for AUTO 1, 2, or 3, the drive will attempt five restarts after a fault. During the interval between restart attempts, the drive will display START PENDING to indicate that the equipment will automatically restart. If all five restart attempts are unsuccessful, the drive will trip into FAULT LOCKOUT, which requires a manual reset. Every 15 minutes that passes will decrement the restart counter by one. Therefore, 75 minutes after a successful restart, the restart counter is fully reset, and the drive can once again attempt five restarts.

NOTE 1: When set for AUTO 1, 2, or 3, only the first two restart attempts will perform a speed search to start into a spinning load. The last three restart attempts will apply DC braking (at the voltage level programmed into Parameter 12 - DC BRAKE) for 15 seconds and then start from zero speed.

NOTE 2: The drive WILL NOT restart after a CONTROL or PWR SAG fault. Also, if an OUTPUT fault occurs below 1.5 Hz, only one restart will be attempted, after a 30 second delay. If unsuccessful, it will then trip into FAULT LOCKOUT, which requires a manual reset. This is done to protect the drive in case of a shorted motor.

26 STOP METHOD

This parameter selects whether the motor will COAST to a stop, or RAMP to a stop, when the drive is given a stop command.

COAST When a stop command is given, the drive shuts off the output to the motor, allowing it to coast to a stop. In this mode, the time it takes the motor to stop is governed by the inertia of the driven load.

RAMP When a stop command is given, the drive will decelerate the motor to a stop over a period of time according to Parameter 9 - DECEL.

28 SPEED SRC KEY (SPEED SOURCE KEY)

This parameter ENABLES or DISABLES the SPEED SOURCE key on the keypad. The SPEED SOURCE key can be used to change the speed reference source. See Section 13.1 - KEYPAD FUNCTIONS.

ENABLED The SPEED SOURCE key is active and can be used to select HAND ONLY, AUTO ONLY, or NORM SRC.

DISABLED The SPEED SOURCE key is disabled and cannot be used to select HAND ONLY, AUTO ONLY, or NORM SRC.

NOTE: If the SPEED SOURCE key is disabled, the drive will respond to the last speed source selected before the SPEED SOURCE key was disabled. For example, if the SPEED SOURCE key was used to select HAND ONLY, and then the SPEED SOURCE key is disabled, the drive speed will be controlled by the HAND SOURCE only.

29 **HAND SOURCE**

This parameter selects the speed reference source that the drive will follow when it is in HAND mode. The following options are possible:

- KEYPAD** The ▲ and ▼ keys control the drive speed.
- 0-10 VDC** The drive will follow a 0-10 VDC signal wired between TB-5A (+) and TB-2 (-).
- 4-20 MA** The drive will follow a 4-20 mA signal wired between TB-5B (+) and TB-2 (-).
- PRESET #1 - #4** The drive will run at a programmable preset speed. Refer to Parameters 1-4.
- MOP** The drive speed is controlled by two contacts (one to increase the speed and the other to decrease the speed). Program TB-13A (Parameter 47) to DECREASE FREQ, and TB-13B (Parameter 48) to INCREASE FREQ. Closing TB-13A to TB-2 will decrease the speed, and closing TB-13B to TB-2 will increase the speed. Refer to Section 14.2.4.
- SELECTED** The drive speed will be determined by whatever speed reference is selected using the TB-13 terminals. Refer to Parameters 47, 48, and 49.

30 **CONTROL**

This parameter affects how the H/O/A modes are selected, and also determines the level of serial control. The following settings are possible:

- NORMAL** H/O/A is selected from the keypad or terminal strip. The serial link can be used for monitoring only; no serial start/stop or speed control.
- NORM NO HAND** Same as NORMAL except HAND mode is disabled. AUTO mode can be selected normally from the keypad or terminal strip.

SERIAL SPEED	H/O/A is selected from the keypad or terminal strip. The serial link can control the drive speed or PID setpoint, but only in AUTO mode. In HAND and OFF modes, serial speed control is disabled. No serial start/stop control.
S SPD / NO HAND	Same as SERIAL SPEED except HAND mode is disabled. AUTO mode can be selected normally from the keypad or terminal strip.
SERIAL AUTO	H/O/A is selected from the keypad or terminal strip. In AUTO mode, only the serial link can start the drive. The serial link can control the drive speed or PID setpoint in AUTO mode only.
S AUTO / NO HND	Same as SERIAL AUTO except HAND mode is disabled. AUTO mode can be selected normally from the keypad or terminal strip.

31 UNITS (SPEED/PID UNITS)

This parameter sets the units of the output speed or the PID display on the keypad. The following choices are available:

speed: HERTZ	pid: CFM (cubic feet per minute)
speed: RPM (revolutions per minute)	pid: GPM (gallons per minute)
speed: %HZ (percent Hertz)	pid: IN (inches)
speed: /SEC (units per second)	pid: FT (feet)
speed: /MIN (units per minute)	pid: /SEC (units per second)
speed: /HR (units per hour)	pid: /MIN (units per minute)
speed: GPH (gallons per hour)	pid: /HR (units per hour)
speed: NONE (no units displayed)	pid: F (degrees Fahrenheit)
pid: % (percent of PID feedback)	pid: C (degrees Celsius)
pid: PSI (pounds per square inch)	pid: MPM (meters per minute)
pid: FPM (feet per minute)	pid: GPH (gallons per hour)

NOTE: If one of the “pid” units is selected, but the drive is in HAND (open-loop) speed control mode or PID MODE is DISABLED, the displayed speed units will default to HERTZ.

32 HZ MULTIPLIER

The HZ MULTIPLIER is used to scale the output speed indication on the display. This parameter is only active when UNITS is set for speed: RPM, speed: /SEC, speed: /MIN, speed: /HR, or speed: GPH. Multiplying the output frequency by the HZ MULTIPLIER will yield the desired speed value on the display.

Example: The desired speed units is RPM with a standard 60 Hz, 1800 RPM motor. Set UNITS to speed: RPM and set HZ MULTIPLIER to 30.00. This will result in a display of 1110 RPM for an output frequency of 37 Hz (37 Hz X 30 = 1110 RPM). Also, if there is a 100:1 gear reducer in the system, Parameter 33 - UNITS DECIMAL below could be set to XX.XX to represent the output of the gear reducer (11.10 RPM in the example).

33 UNITS DECIMAL (UNITS DECIMAL POINT)

In “non-PID” mode, UNITS DECIMAL selects the decimal point location of the speed display. UNITS DECIMAL has no effect if UNITS is set to speed: HERTZ or speed: % HZ.

In PID mode, UNITS DECIMAL selects the decimal point location for the PID SETPOINT and FEEDBACK displays, and FEEDBACK @ MIN and FEEDBACK @ MAX.

The possible settings are: XXXXX, XXX.X, XX.XX, X.XXX, and .XXXX. Refer to the above example in Parameter 32 - HZ MULTIPLIER.

34 LOAD MULTIPLY

This parameter is used to scale the % LOAD display. If the drive output current rating is higher than the motor full load current rating, the drive will not display 100% load when the motor is at full load. Setting this parameter to the ratio (in %) of the drive output current rating to the motor full load current rating will scale the load display to show motor load instead of drive load. This will result in a display of 100% when the motor is at full load.

The motor overload circuitry is also affected by this parameter. When the display reads 120% load, the drive will trip on OVERLOAD in one minute, regardless of the actual motor current. If this parameter is used to scale the display to show actual motor load, then Parameter 17 - MOTOR OL should be left at 100%. Likewise, if MOTOR OL has been set according to the motor full load rating, this parameter should be left at 100%. Changing both parameters will result in an OVERLOAD fault sooner than expected.

The output signal at TB-10B is also affected by this parameter. When set to the ratio of current ratings as explained above, the output signal will be proportional to motor load instead of drive load.

35 LCD CONTRAST

This parameter is used to adjust the contrast of the drive display and can be set to LOW, MED, or HIGH in order to obtain the most visible display. If the drive is mounted lower than eye level, a HIGH setting may make the display more visible. Likewise, if the drive is mounted higher than eye level, a LOW setting

may make the display more visible.

36 **SLEEP THRSHL** (SLEEP THRESHOLD)

The MCH Series drive has a Sleep Mode function that allows the drive to cease operation when system demand falls below a preset level. This is to prevent the motor from operating at low speeds for long periods of time. It is commonly used along with the PID Setpoint Control feature, but can also be used in standard speed control mode.

When the commanded speed falls below the SLEEP THRESHOLD setting for the defined SLEEP DELAY time (see Parameter 37 below), the drive will "go to sleep" and the motor will go to zero speed. The drive will remain "sleeping" until it is commanded to operate at a speed that is 2 Hz above the SLEEP THRESHOLD, at which point it will "wake up" and ramp the motor up to the commanded speed.

NOTE 1: While the the drive is in Sleep Mode, the Status portion of the display will read SLEEP.

NOTE 2: If the drive's commanded speed goes below the SLEEP THRESHOLD, the SLEEP DELAY timer will start to count down. If the commanded speed equals or exceeds the SLEEP THRESHOLD before the SLEEP DELAY times out, the SLEEP DELAY timer will be reset.

NOTE 3: If the drive is in a Stop state, and the commanded speed is below the SLEEP THRESHOLD, the drive will immediately go to sleep upon a Start command, bypassing the SLEEP DELAY.

37 **SLEEP DELAY**

This parameter sets the amount of time the drive must operate below the SLEEP THRESHOLD (see Parameter 36 above) before the drive "goes to sleep" and brings the motor to zero speed.

Example: SLEEP THRESHOLD is set to 15 Hz and SLEEP DELAY is set to 60 seconds. If the drive operates below 15 Hz for 60 seconds, the drive will "go to sleep" and the motor will stop. The drive's display will indicate SLEEP, and the drive will remain "sleeping" until the drive is commanded to a speed equal to or greater than 17 Hz. At this point, the drive will "wake up" and ramp the motor up to the commanded speed. This example assumes that SLEEP BANDWIDTH (Parameter 38) is set to 0.

38 **SLEEP BANDWID** (SLEEP BANDWIDTH)

This parameter allows the PID feedback signal to determine when drive should "wake up" when operating in Sleep Mode. In process systems that utilize Integral Gain (see Parameter 78), the drive may cycle in and out of Sleep Mode more often than desired, due to the Integral function of the PID algorithm.

When SLEEP BANDWIDTH is used, the feedback signal must decrease or increase (depending on whether the system is normal or reverse-acting) by the programmed amount before the drive will "wake up". This parameter is set in PID units.

Example: In a normal-acting system, the PID setpoint is 50 PSI, SLEEP THRESHOLD is set to 20 Hz, and SLEEP BANDWIDTH is set to 5 PSI. The drive will enter Sleep Mode when the commanded speed drops below 20 Hz for the time defined in SLEEP DELAY. The drive will wake up when the feedback signal drops below 45 PSI (50 PSI setpoint minus 5 PSI bandwidth = 45 PSI), even if the commanded speed is still below 20 Hz.

NOTE: If SLEEP BANDWIDTH is set to 0, this function is disabled, and the drive will wake up when the commanded speed exceeds the SLEEP THRESHOLD plus 2 Hz, as described in Parameters 36 and 37.

39 TB5 MIN FREQ

This parameter sets the output frequency of the drive that will correspond to the minimum analog speed reference input (0 VDC or 4 mA). This parameter is used in conjunction with Parameter 40 - TB5 MAX FREQ to define a speed range that corresponds to the analog speed reference input (0-10 VDC or 4-20 mA).

40 TB5 MAX FREQ

This parameter sets the output frequency of the drive that will correspond to the maximum analog speed reference input (10 VDC or 20 mA). This parameter is used in conjunction with Parameter 39 - TB5 MIN FREQ to define a speed range that corresponds to the analog speed reference input (0-10 VDC or 4-20 mA).

Example: The drive is required to operate from 0 to 60 Hz in response to a 0-5 VDC speed reference signal (rather than the "normal" 0-10 VDC). Because TB5 MAX FREQ is based on a 0-10 VDC (or 4-20 mA) signal, the drive will operate at half of the TB5 MAX FREQ value if it is given a 5 VDC signal. Therefore, setting TB5 MAX FREQ to 120 Hz will cause the drive to run at 60 Hz when it is given a 5 VDC speed reference signal.

NOTE: The drive can be programmed for inverse operation so that as the speed reference increases, the drive speed will decrease, and as the speed reference decreases, the drive speed will increase. This is accomplished by setting TB5 MIN FREQ to the desired maximum output frequency, and TB5 MAX FREQ to the desired minimum output frequency.

41 AN INPUT FLTR (ANALOG INPUT FILTER)

This parameter adjusts the filter on the analog input terminals (TB-5A and TB-5B) to reduce the effect of any electrical noise that may be present on the analog input signals.

This filter works in both PID mode and standard speed control mode. It should be set to the lowest value that yields acceptable performance, as setting it too high may cause the drive to react too slowly to signal changes.

42 TB10A OUTPUT

The analog output signal at TB-10A is proportional to the output frequency of the drive. This parameter selects whether that signal is 0-10 VDC or 2-10 VDC. The 2-10 VDC signal can be converted to a 4-20 mA signal by connecting a resistor in series with the signal such that the total circuit resistance is 500 Ohms. If set to NONE, the function is disabled.

NOTE: This output cannot be used with “loop-powered” devices that derive power from a 4-20 mA signal.

43 TB10A SCALING

This parameter scales the analog output signal at TB-10A. This setting is the output frequency that is indicated when the TB-10A output measures 10 VDC.

Example: The drive is part of a control system that requires a 0-5 VDC signal (rather than 0-10 VDC) that is proportional to 0-60 Hz output frequency. The output signal is linear, so setting this parameter to 120 Hz would yield 10 VDC at 120 Hz, and 5 VDC at 60 Hz.

44 TB10B OUTPUT

The analog output signal at TB-10B is proportional to the drive load. This parameter selects whether that signal is 0-10 VDC or 2-10 VDC. The 2-10 VDC signal can be converted to a 4-20 mA signal by connecting a resistor in series with the signal such that the total load resistance is 500 Ohms.

NOTE: This output cannot be used with “loop-powered” devices that derive power from a 4-20 mA signal.

45 TB10B SCALING

This parameter scales the analog output signal at TB-10B. This setting is the load (in %) that is indicated when the TB-10B output measures 10 VDC.

Example: The drive is part of a control system that requires a 0-10 VDC signal to indicate 0-120% drive load. If this parameter is set to 120%, the drive will output 10 VDC at 120% load (and about 8.3 VDC at 100% load).

NOTE: The output signal at TB-10B is affected by the setting of Parameter 34 - LOAD MULTIPLY.

47 TB13A INPUT

This parameter is used to select the function of terminal TB-13A. Closing TB-13A to TB-2 activates the TB-13A input function. The following functions can be selected:

NONE	Disables the TB-13A function.
0-10VDC	Selects 0-10 VDC as the speed reference input (or setpoint source in PID mode). The 0-10 VDC signal is wired to TB-5A (+) and TB-2 (-).
4-20 MA	Selects 4-20 mA as the speed reference input (or setpoint source in PID mode). The 4-20 mA signal is wired to TB-5B (+) and TB-2 (-).
PRESET #1	Selects PRESET #1 (Parameter 1) as the speed reference.
DEC FREQ	Decrease frequency setpoint. Used with the MOP (motor operated pot) function. Refer to Section 14.2.6 - SPEED REFERENCE SELECTION.
REVERSE	Selects Reverse motor rotation. This function can be used for cooling tower de-icing.

48 TB13B INPUT

This parameter is used to select the function of terminal TB-13B. Closing TB-13B to TB-2 activates the TB-13B function. The following functions can be selected:

NONE	Disables the TB-13B function.
0-10VDC	Selects 0-10 VDC as the speed reference input (or setpoint source in PID mode). The 0-10 VDC signal is wired to TB-5A (+) and TB-2 (-).
4-20 MA	Selects 4-20 mA as the speed reference input (or setpoint source in PID mode). The 4-20 mA signal is wired to TB-5B (+) and TB-2 (-).
PRESET #2	Selects PRESET #2 (Parameter 2) as the speed reference.
INC FREQ	Increase frequency setpoint. Used with MOP (motor operated pot) function. Refer to Section 14.2.6 - SPEED REFERENCE SELECTION.

49 TB13C INPUT

This parameter is used to select the function of terminal TB-13C. Closing TB-13C to TB-2 activates the TB-13C input function. The following functions can be selected:

NONE	Disables the TB-13C function.
0-10VDC	Selects 0-10 VDC as the speed reference input (or setpoint source in PID mode). The 0-10 VDC signal is wired to TB-5A (+) and TB-2 (-).
4-20 MA	Selects 4-20 mA as the speed reference input (or setpoint source in PID mode). The 4-20 mA signal is wired to TB-5B (+) and TB-2 (-).
PRESET #3	Selects PRESET #3 (Parameter 3) as the speed reference.
HAND	Selects HAND mode. TB-1 to TB-2 must be closed for the drive to start when TB-13C is closed to TB-2.
REVERSE	Selects Reverse motor rotation. This function can be used for cooling tower de-icing.

NOTE: On drives equipped with the Bypass option, TB-13C is factory set to HAND and cannot be changed.

50 TB13D INPUT

WARNING!

EXTERNAL FAULT (TB-13D) circuitry may be disabled if parameters are reset to factory defaults! The drive must be reprogrammed after a RESET in order to insure proper operation (see Parameter 65 - PROGRAM).

FAILURE TO DO SO MAY RESULT IN DAMAGE TO EQUIPMENT AND/OR INJURY TO PERSONNEL!

This parameter selects the function for TB-13D. The following settings are available:

EXTERN FAULT	Sets TB-13D as a normally open EXTERNAL FAULT contact. Close TB-13D to TB-2 to trip the drive into an EXTERNAL FAULT.
EXTERN / FAULT	Sets TB-13D as a normally closed EXTERNAL FAULT contact. Open TB-13D to TB-2 to trip the drive into an EXTERNAL FAULT.

EXTERN CLEAR Sets TB-13D as a normally open EXTERNAL FAULT RESET. Close TB-13D to TB-2 to clear a fault.

NOTE: When set to EXTERN CLEAR, TB-13D becomes the only terminal that can be used to clear a fault (TB-1 will not work). However, the keypad OFF (STOP) key can still be used to clear faults.

52 **TB14/RELAY #2**

This parameter sets the open-collector output indication for terminal TB-14. The following conditions can be selected:

NONE	This setting disables the output.
RUN	The relay energizes when the drive is given a START command, and remains energized until: a STOP command is given and the output frequency has decelerated to 0.5 Hz, the drive has “tripped”, or the input voltage is removed. Note that this relay indicates only that the drive is in the RUN mode. It does not necessarily indicate that the motor is turning.
FAULT	The relay energizes when input voltage is applied to the drive and remains energized until the drive “trips” into a fault condition, or input voltage is removed.
INVERSE FAULT	The relay energizes when the drive “trips” into a fault condition, and remains energized until the fault condition is cleared.
FAULT LOCKOUT	This setting is used when the drive is programmed to automatically restart after a fault. The relay energizes when input voltage is applied to the drive and remains energized until the drive has faulted and unsuccessfully attempted five restarts, or input voltage is removed.
AT SPEED	The relay energizes when the drive reaches the speed setpoint. To avoid a “chattering” relay (energizing and de-energizing), due to small fluctuations in speed, the relay will remain energized as long as the actual speed is within ± 3 Hz of the speed setpoint.
ABOVE PRSET #3	ABOVE PRESET SPEED #3 - The relay energizes when the output frequency exceeds the PRESET #3 value, and de-energizes when the output frequency returns to a value lower than the PRESET #3 value. See Parameter 3 - PRESET #3 in Section 18.0 - DESCRIPTION OF PARAMETERS.

CURRENT LIMIT	The relay energizes when the drive is operating in current limit. Once the current limit relay is energized, it remains energized for a minimum of 500ms, regardless of whether the drive is still in current limit. At the end of the 500ms interval, the relay will de-energize if the drive is no longer in current limit. See Parameter 16 - CURRENT in Section 18.0 - DESCRIPTION OF PARAMETERS.
AUTO/HAND SRC	The relay energizes when the drive speed is controlled by the AUTO SOURCE, and de-energizes when the drive speed is controlled by the HAND SOURCE. Refer to Section 14.2.4 - SPEED REFERENCE SELECTION.
FOLLOWER PRES	FOLLOWER PRESENT - The relay energizes when the analog input reference signal at TB-5B is greater than 2 mA, and de-energizes if the signal falls below 2 mA.
MIN/MAX ALARM	The relay de-energizes when the feedback signal (in PID mode) or the speed reference signal (in open-loop speed mode) is within the limits set by MIN ALARM and MAX ALARM (Parameters 81 and 82), and energizes when the signal falls below the MIN ALARM setting or exceeds the MAX ALARM setting.
INV MIN/MAX A	INVERSE MIN/MAX ALARM - The relay energizes when the feedback signal (in PID mode) or the speed reference signal (in open-loop speed mode) is within the limits set by MIN ALARM and MAX ALARM (Parameters 81 and 82), and de-energizes when the signal falls below the MIN ALARM setting or exceeds the MAX ALARM setting.
MIN ALARM	The relay de-energizes when the feedback signal (in PID mode) or the speed reference signal (in open-loop speed mode) equals or exceeds the MIN ALARM setting (Parameter 81), and energizes when the signal falls below the MIN ALARM setting.
INV MIN ALARM	INVERSE MIN ALARM - The relay energizes when the feedback signal (in PID mode) or the speed reference signal (in open-loop speed mode) equals or exceeds the MIN ALARM setting (Parameter 81), and de-energizes when the signal falls below the MIN ALARM setting.
MAX ALARM	The relay de-energizes when the feedback signal (in PID mode) or the speed reference signal (in open-loop speed mode) is less than or equal to the MAX ALARM setting (Parameter 82), and energizes when the signal exceeds the MAX ALARM setting.

56 SERIAL LOSS (LOSS OF SERIAL LINK ACTION)

This parameter selects the action taken by the drive if the serial link is lost. The serial link is considered lost if there is no serial activity for 10 seconds.

FAULT	The drive will trip into a FLWR/SER fault condition.
AUTO	The drive will operate according to the speed reference defined by Parameter 24 - AUTO SOURCE.

57 SERIAL COMM

This parameter is used to activate serial communications. When using this feature, the drive can communicate with a personal computer (PC), programmable logic controller (PLC), or other external device that utilizes RS-485 serial communications for control. The serial interface may be used to read present parameter settings (uploading to the control device), write new parameter settings (downloading from the control device), monitor present drive activity, and control drive activity. The following settings are available:

DISABLED	Serial communication function is disabled.
WITH TIMER	Enables serial communications with a watchdog timer. If there is no serial activity (read or write) for more than 10 seconds, the drive will either trip into a fault, or go to the speed reference selected in Parameter 24 - AUTO SOURCE, depending on the setting of Parameter 56 - SERIAL LOSS.
W/O TIMER	Enables serial communications without a watchdog timer. However, after 10 seconds of no serial activity, serial control can be turned off by issuing a STOP command from any source (keypad, terminal strip) other than the serial link.

NOTE: If a RESET command (Parameter 65 - PROGRAM) is issued through the serial link, this parameter will not default back to DISABLED. However, explicitly setting this parameter to DISABLED through the serial link will cut off communication with the drive.

Modbus is the standard protocol for the MCH. Optional protocols that are available are: BACnet, LON Works, Metasys N2, and Siemens P1. Please refer to the AC Tech website (www.actechdrives.com) for documentation on these protocols.

58 SERIAL ADDRES

This parameter is used with the serial communications feature, and is intended for use in a multiple drive network (RS-485). The serial link will support drives with addresses from 1 up to 247.

61 PASSWORD

This feature limits access to the programmable parameters for added security. The correct password must be entered in order to change the parameters.

Pressing the PROG/RUN button on the keypad will activate the PASSWORD prompt. If the correct password is entered, the PROGRAM MODE is entered and parameters can be changed.

If the wrong password is entered, the display will flash ERROR: INCORRECT and then return to the PASSWORD prompt to allow another attempt at entering the correct password.

If the ENTER key is pressed while PASSWORD reads 0000, the MONITOR MODE will be entered (if Parameter 64 - MONITOR, is set to ON), which will allow the parameters to be viewed (except for PASSWORD), but not changed.

NOTE 1: The factory default value is 0019.

NOTE 2: If PASSWORD is set to 0000, the function is disabled. Pressing the PROG/RUN key will result in direct entry into the PROGRAM mode without having to enter a password.

63 SOFTWARE VERS

This parameter displays the software code and revision number of the control board software. This information is useful when contacting the factory for programming or troubleshooting assistance. This is a “view-only” parameter, and cannot be changed.

64 MONITOR MODE

This parameter is used to enable (ON) or disable (OFF) the MONITOR MODE function. The functionality is explained below:

ON Pressing the PROG/RUN key will activate the PASSWORD prompt. If the ENTER key is pressed while the password value reads 0000, the MONITOR MODE is entered and parameters can be viewed (except for PASSWORD), but not changed.

OFF Pressing the PROG/RUN key will activate the PASSWORD prompt. If the ENTER key is pressed while the password value reads 0000, it will be treated as in incorrect password and the display will flash ERROR: INCORRECT, and then return to the PASSWORD prompt to allow another attempt at entering the correct password.

65 PROGRAM (PROGRAM FACTORY DEFAULTS)

WARNING!

EXTERNAL FAULT (TB-13D) circuitry may be disabled if parameters are reset to factory defaults! The drive must be reprogrammed after a RESET in order to insure proper operation.

FAILURE TO DO SO MAY RESULT IN DAMAGE TO EQUIPMENT AND/OR INJURY TO PERSONNEL!

This parameter is used to reset the programmable parameters back to the factory default settings for 60 Hz or 50 Hz systems:

MAINTAIN	Maintain parameter settings as they are.
RESET 60	Resets the parameters back to the factory defaults for 60 Hz base frequency.
RESET 50	Resets the parameters back to the factory defaults for 50 Hz base frequency.

NOTE: When a reset is performed, TB-13D will default to a normally open EXTERNAL FAULT contact because Parameter 50 - TB13D will be reset to EXTERN FAULT.

66 CLEAR HISTORY

This parameter is used to clear the previous faults in the FAULT HISTORY (Parameter 99). When set to CLEAR and the ENTER key is pushed, the display will change to MAINTAIN, and the FAULT HISTORY will display NO FAULT for each of the eight fault histories.

70 PID MODE

This parameter activates the PID function, and selects whether the PID control will be direct or reverse acting. Refer to Section 19.0 - MCH PID SETPOINT CONTROL. The following options are available:

OFF	Disables the PID function to allow “standard” drive operation.
NORMAL	Enables the PID function for direct-acting systems. An increase in the feedback variable will cause a decrease in motor speed.
REVERSE	Enables the PID function for reverse-acting systems. An increase in the feedback variable will cause an increase in motor speed.

NOTE: The REVERSE selection is not used to compensate for reverse acting feedback devices. If a reverse acting feedback device is used, program Parameters 75 and 76 - FEEDBACK @ MIN and FEEDBACK @ MAX as described in Section 19.1 - FEEDBACK DEVICES.

When PID is enabled, and the drive is in AUTO mode, the drive will operate in a CLOSED LOOP fashion, responding to the feedback signal in order to maintain the process setpoint. In this case, the PID setpoint reference is controlled by the source defined by AUTO SOURCE (Parameter 24). The SPEED REFERENCE SOURCE indication in the CONTROL display will indicate AKB (keypad), VDC (0-10 VDC), or IDC (4-20 mA), depending on the setpoint reference source.

When PID is enabled, and the drive is in HAND mode, the drive will operate in an OPEN LOOP fashion, responding directly to speed commands from the keypad or Preset #3, depending on the setting of HAND SOURCE (Parameter 29). In this configuration, the other settings in HAND SOURCE are disabled, and speed control will default to the keypad.

When PID is disabled, the drive will operate in an OPEN LOOP fashion, responding directly to speed commands from the selected speed reference source (HAND SOURCE or AUTO SOURCE).

74 PID FEEDBACK

This parameter selects the terminal to be used for the feedback signal, and can be set to TB-5A or TB-5B. TB-5A is used for 0-10 VDC signals, and TB-5B is used for 4-20 mA signals.

NOTE: The MCH has only one analog input of each type, so the same type of signal cannot be used for feedback and setpoint reference. For example, a 4-20 mA signal from a transducer could not be used as a feedback signal if the setpoint is being controlled by a 4-20 mA signal from a PLC.

75 FEEDBACK @ MIN

This parameter should be set to the value of the process variable that corresponds to the minimum transducer feedback signal (0 VDC or 4 mA).

76 FEEDBACK @ MAX

This parameter should be set to the value of the process variable that corresponds to the maximum transducer feedback signal (10 VDC or 20 mA).

Example: A 0-100 psi transducer outputs 4 mA at 0 psi and 20 mA at 100 psi. Set FEEDBACK @ MIN to 0.0 PSI, and set FEEDBACK @ MAX to 100.0 PSI (this assumes that Parameter 31 - UNITS is set to pid: PSI, and Parameter 33 - UNITS DECIMAL is set to XXX.X).

NOTE: If a reverse-acting feedback device is being used, FEEDBACK @ MIN should be set to the maximum process variable value, and FEEDBACK @ MAX should be set to the minimum process variable value.

77 PROPOR. GAIN (PROPORTIONAL GAIN)

The Proportional Gain setting represents the speed command output (in % of maximum speed) that results from each 1% of error (1% of Parameter 75 - FEEDBACK @ MIN or 76 - FEEDBACK @ MAX, whichever is larger).

Example: If PROPOR. GAIN is programmed for 5%, and the error (difference between setpoint and feedback) is 10%, the speed command output of the Proportional term is 50% ($10 \times 5 = 50$) of maximum speed.

78 INTEGRAL GAIN

The Integral Gain setting represents the ramp rate of the speed command output (in % of maximum speed per second) that results from each 1% of error.

Example: If INTEGRAL GAIN is programmed for 0.5 seconds, and the error is 5%, the rate of rise of the speed command output from the Integral term is 2.5% ($0.5 \times 5 = 2.5$) of maximum speed per second.

79 DIFF. GAIN (DIFFERENTIAL GAIN)

The Differential Gain setting represents the speed command output (in % of maximum speed) that results from each 1% per second change in the error.

Example: If DIFF. GAIN is programmed for 5 seconds, and the error is increasing at 2% per second, the speed command output of the Differential term is 10% ($5 \times 2 = 10$) of maximum speed.

NOTE: Differential gain is used as a “shock-absorber” to dampen overshoots in fast-acting systems. However, it can be very sensitive to “noise” on the feedback signal and to digitizing errors, so it must be used with caution.

80 PID ACCEL (PID ACCEL/DECEL)

This parameter sets the acceleration and deceleration rate of the setpoint reference into the PID unit. When the setpoint changes, this function will “filter” the input to the PID unit by ramping the setpoint reference from the previous value to the new value. This will help prevent overshoots that can occur when the PID control attempts to respond to step changes in setpoint, resulting in smoother operation. If PID ACCEL is set to 0.0 seconds, it is effectively disabled.

81 MIN ALARM

This parameter setting represents the value that the feedback signal (in PID mode), or speed reference signal (in open-loop speed mode), must fall below to activate the MIN ALARM output (see Parameters 52 - 54).

82 MAX ALARM

This parameter setting represents the value that the feedback signal (in PID mode), or speed reference signal (in open-loop speed mode) must exceed to activate the MIN ALARM output (see Parameters 52 - 54).

NOTE 1: The MIN ALARM function can be used to start and stop the drive based on the level of the speed reference signal or PID feedback signal. This is done by wiring a 2-wire start/stop circuit through the drive's Form C relay or open-collector output, and setting the Form C relay or open-collector output for MIN ALARM (see Parameters 52 - 54). When the signal drops below the MIN ALARM setting, the relay or open-collector output will de-energize, which opens the start contact and stops the drive. When the signal is equal to or greater than the MIN ALARM setting, the relay or open-collector output will energize, which closes the start contact and starts the drive. The drive must be in AUTO mode to use the MIN ALARM function to start and stop the drive.

NOTE 2: In order to use the MIN and MAX ALARM functions in non-PID mode, PID FEEDBACK (Parameter 74) must still be programmed to match the speed reference signal.

98 LANGUAGE (LANGUAGE SELECTION)

The MC Series drive can support other languages with the addition of an optional LANGUAGE EEPROM chip installed in socket U11 on the control board of the drive. If the EEPROM is not present, the default language will be ENGLISH. Also, this parameter is not affected when the parameters are reset using Parameter 65 - PROGRAM. Therefore, if a language other than ENGLISH is selected, it will remain in effect after a RESET.

99 FAULT HISTORY

The FAULT HISTORY stores the previous eight fault conditions that caused the drive to trip. The information stored here is view-only, it cannot be altered. The FAULT HISTORY can be used to determine if there is a pattern, or trend, to the faults, which may indicate a problem in the system. Refer to Section 20.0 - TROUBLESHOOTING for more information on faults.

The FAULT HISTORY indicates the number of the fault (number 1 is the most recent fault), the fault message, and the status of the drive at the time of the fault. An example is shown below:

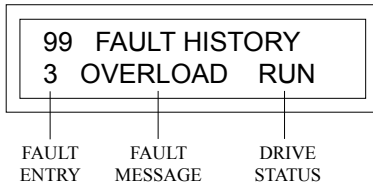

In the example above, the third fault entry is being viewed, which is an OVERLOAD fault that occurred while the drive was in a RUN state.

19.0 MCH PID SETPOINT CONTROL

PID Setpoint Control allows the MCH drive to maintain a process setpoint, such as PSI or CFM, without using an external controller. When PID is activated (and the drive is in AUTO mode), the MCH will operate in a closed-loop fashion, automatically adjusting the motor speed to maintain the setpoint.

PID setpoint control requires feedback from the process in order to compare the process variable “value” to the setpoint. The difference between the process variable “value” and the setpoint is called the error. The MCH will increase or decrease the motor speed in an attempt to minimize the error. By constantly adjusting the motor speed, the PID control will drive the process toward the setpoint. Refer to the PID block diagram below:

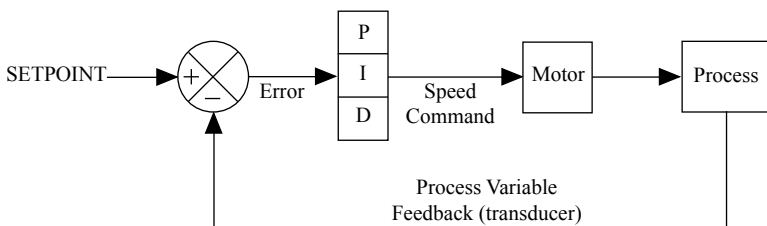

19.1 FEEDBACK DEVICES

A transducer or transmitter is required to monitor the process variable and provide feedback to the PID unit in order to compare the process variable feedback to the setpoint. A transducer outputs a signal corresponding to a fixed range of the process variable. A transmitter provides offset and gain adjustments to allow the output signal to be adjusted to correspond to different ranges of the process variable. Typical output signals for transducers and transmitters are: 0-5 VDC, 0-10 VDC, or 4-20 mA. The feedback device must be externally powered, as the drive does not have a power supply for such devices. Program Parameter 74 - PID FEEDBACK for the appropriate terminal (TB-5A or TB-5B), and connect the feedback device as described below:

POT	The positive signal wire (wiper) is connected to TB-5A, and the “high” lead is connected to TB-6.
0-5, 0-10 VDC	Connect the positive signal wire to TB-5A.
4-20 mA	Connect the positive signal wire to TB-5B.

The common, or negative signal wire, is connected to TB-2 (circuit common).

Feedback devices can be direct or reverse acting. A direct acting device outputs a signal that increases as the process variable increases. A reverse acting device outputs a signal that decreases as the process variable increases. The programming of Parameters 75 - FEEDBACK @ MIN and 76 - FEEDBACK @ MAX depend on the type of feedback device being used.

When using a direct acting transducer, Parameter 75 - FEEDBACK @ MIN should be set to the value of the process variable feedback corresponding to the minimum feedback signal (0 VDC or 4 mA), and Parameter 76 - FEEDBACK @ MAX should be set to the value of the process variable feedback corresponding to the maximum feedback signal (5 or 10 VDC, or 20 mA). See the example below:

Example 1: A 0-100 psi transducer outputs a 4 mA signal at 0 psi and 20 mA at 100 psi. Program Parameter 75 to 0.0 PSI, and Parameter 76 to 100.0 PSI (this assumes that Parameter 31 - UNITS is set to pid: PSI, and Parameter 33 - UNITS DECIMAL is set to XXX.X).

For a reverse acting transducer, set Parameter 75 - FEEDBACK @ MIN to the maximum process variable feedback value, and set Parameter 76 - FEEDBACK @ MAX to the minimum process variable feedback value. In other words, Parameter 75 is set higher than Parameter 76. See the example below:

Example 2: A 0-100 psi transducer outputs a 20 mA signal at 0 psi and 4 mA at 100 psi. Program Parameter 75 to 100.0 PSI, and Parameter 76 to 0.0 PSI (This assumes that Parameter 31 - UNITS is set to pid: PSI, and Parameter 33 - UNITS DECIMAL is set to XXX.X).

19.2 THE SYSTEM - DIRECT AND REVERSE ACTING

The entire system can also be direct or reverse acting. In a direct acting system, an increase in motor speed causes an increase in the process variable. This is equivalent to requiring an increase in motor speed in response to a decreasing process variable feedback.

In a reverse acting system, an increase in motor speed causes a decrease in the process variable. This is equivalent to requiring an increase in motor speed in response to an increasing process variable feedback. Examples of direct and reverse acting systems are described in the next section.

19.3 PID CONTROL - DIRECT AND REVERSE ACTING

The PID Setpoint Control software can be direct or reverse acting, and must be set to match the system. This is accomplished with Parameter 70 - PID MODE. When set to NORMAL (for direct acting systems), the PID unit will command an increase in motor speed if the process variable feedback decreases, and a decrease in motor speed if the process variable feedback increases. When set to REVERSE (for reverse acting systems), the opposite is true.

NOTE: Do not use the REVERSE setting for Parameter 70 - PID MODE to compensate for reverse acting feedback devices. If a reverse acting feedback device is used, program Parameters 75 and 76 as described above in Section 19.1.

An example of a direct acting system is one that maintains duct pressure. Duct pressure is the process variable that is monitored by the feedback device. As duct pressure rises, motor speed needs to be decreased to maintain the pressure. A direct acting PID control will command a decrease in motor speed in response to an increasing process variable feedback.

An example of a reverse acting system is one that maintains water temperature in a cooling tower. Water temperature is the process variable that is monitored by the feedback device. As the water temperature rises, motor speed needs to be increased to lower the temperature of the water. A reverse acting PID control will command an increase in motor speed in response to an increasing process variable feedback.

19.4 SETPOINT REFERENCE SOURCES

The setpoint reference input can be one of the following:

1. Keypad (▲ and ▼ keys)
2. 4-20 mA signal at TB-5B
3. 0-10 VDC signal at TB-5A
4. Potentiometer signal at TB-5A
5. PRESET #1, #2, and #4 (Parameters 1, 2, and 4)

Parameter 24 - AUTO SOURCE selects the PID setpoint reference. If more than one setpoint reference is required, then AUTO SOURCE must be set to SELECTED, and the TB-13 terminals must be used to select the desired reference.

NOTE: The default setting of AUTO SOURCE is 4-20 MA, so AUTO SOURCE must be changed if the setpoint reference is anything other than a 4-20 mA signal.

Remote setpoint reference inputs at TB-5A and TB-5B can only be used if that terminal is NOT being used for the process feedback signal from a transducer. The MCH has only one analog input of each type, so the same type of signal cannot be used for transducer feedback and setpoint reference. For example, a 4-20 mA signal from a transducer could not be used as a feedback signal if the setpoint is being controlled by a 4-20 mA signal from a PLC.

If the keypad is the setpoint reference source, the ▲ and ▼ keys are used to adjust the setpoint. This is done while the drive is in the "normal" operation display. See the example below:

Example PID setpoint of 35.0 PSI

42.53 HZ	35.0 PSI
57 % LOAD	AUTO

To change the PID setpoint, simply press the ▲ and ▼ keys (example setting changed to 40.5 PSI)

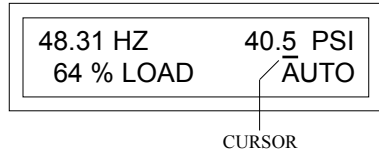

19.5 TUNING THE PID CONTROL

Once the PID control is set up correctly, it needs to be tuned in order to maintain the process setpoint. First, set the Integral and Differential Gains to zero, and increase the Proportional Gain (Parameter 77) until the system becomes unstable, then lower the gain until the system stabilizes again. Set the Proportional Gain about 15% less than that value that stabilizes the system. If only Proportional Gain is used, and the system is operating in a steady-state condition (setpoint is fixed and process variable has settled to a fixed value), there will always be a certain amount of error in the system. This is called the steady-state error.

Integral Gain (Parameter 78) is used to force the steady-state error to zero by increasing the output speed command with respect to time. Over time, the error will be forced to zero because the Integral term will continue to change the speed command, even after the Proportional term reaches steady state and no longer affects the speed command. The Integral Gain affects the rate of rise of the output speed command from the Integral term. Small amounts of Integral Gain can cause large changes in PID performance, so care must be taken when adjusting Integral Gain. Too much Integral Gain will result in overshoots, especially if large step changes in error occur.

Typically, Proportional and Integral Gain are all that is needed to fine-tune the system. However, it may be necessary to use Differential Gain (Parameter 79) to further stabilize the system, especially when quick responses are required. The Differential term responds to the rate of change of the error, not the actual error itself. Differential Gain acts like a “shock-absorber” to dampen overshoots that can occur when the PID tries to react quickly to changes in error or setpoint. This allows fast PID response, with reduced risk of becoming unstable due to overshoots. The Differential term is very sensitive to electrical noise on the feedback signal and to digitizing errors, so it must be used with caution.

The other parameter setting that affects the response of the PID control is Parameter 80 - PID ACCEL. This sets the acceleration (and deceleration) rate of the setpoint reference into the PID unit. When the setpoint changes, this function will “filter” the input to the PID unit by ramping the setpoint reference from the previous value to the new value. This will help prevent overshoots that can occur when the PID control attempts to respond to step changes in setpoint, resulting in smoother operation. If PID ACCEL is set to 0.0 seconds, it is effectively disabled.

19.6 MCH DISPLAY IN PID MODE

When the drive is in PID mode, the DRIVE STATUS portion of the display will indicate actual output frequency (in Hertz) instead of RUN, and the bottom left part of the display will indicate % LOAD, VAC, or PID FEEDBACK. The ENTER key is used to toggle between the different displays. Examples of the possible displays are shown below:

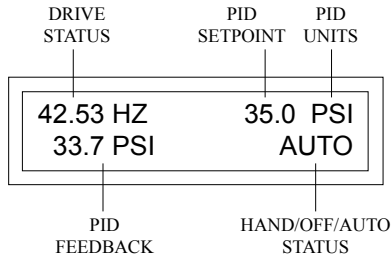
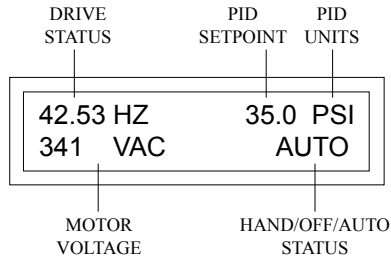
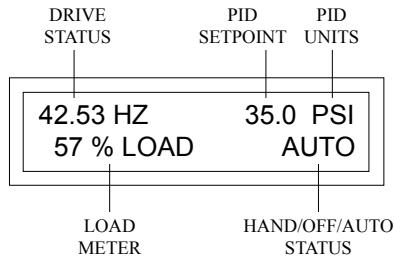

In the examples above, the drive is running at 42.53 Hz to maintain the PID SETPOINT of 35.0 psi. The load is 57%. Pressing the ENTER key displays motor voltage, which is 341 Vac. Pressing ENTER again displays the PID FEEDBACK from the process, which is 33.7 psi.

When the PID FEEDBACK display is selected, the display will flash FEEDBACK before displaying the value to indicate what is being displayed.

20.0 TROUBLESHOOTING

The table below lists the fault conditions that will cause the drive to shut down, as well as some possible causes. Please contact the factory for more information on troubleshooting faults.

NOTE: The drive will not automatically restart after a PWR SAG or a CONTROL fault. Also, if an OUTPUT fault occurs below 1.5 Hz, the drive will only attempt one restart, after a four minute delay. If unsuccessful, it will then trip into FAULT LOCKOUT, which will require a manual reset. This is done to protect the drive in case of a shorted motor.

FAULT MESSAGES		
FAULT	DESCRIPTION	POSSIBLE CAUSES
OUTPUT	Output transistor fault: Output current exceeded 200% of drive rating.	Phase to ground short. Phase to phase short. FX BOOST set too high. Bad transistor module (IPM).
LO VOLTS	Low DC Bus Voltage fault: DC bus voltage below 60% of normal.	Low line voltage.
HI VOLTS	High DC Bus Voltage fault: DC bus voltage above 120% of normal.	High line voltage. Overhauling load. DECEL rate is set too fast.
HI TEMP	Temperature fault: Internal drive temperature too high.	Ambient temperature too high. Fan failure (if equipped).
OVERLOAD	Current Overload fault: Output current rating exceeded for too long.	Drive undersized for the application. Problem with motor and/or driven equipment.
PWR TRAN	Power Transient fault: Low line voltage.	AC line dipped or sagged.

FAULT MESSAGES		
FAULT	DESCRIPTION	POSSIBLE CAUSES
PWR SAG	Power Sag fault: Control board voltage is below tolerance. A new control board has been installed that is different from the previous version.	Erratic AC line. Perform a factory reset using Parameter 65-PROGRAM. This will update the software and allow the fault to be reset.
LANGUAGE	Language fault: Selected language not present	Defective language EEPROM. Language EEPROM (U11) removed after programming.
EXTERNAL	External fault: TB-13D is open or closed to TB-2, depending on setting of Parameter 50 - TB13D.	Check setting of Parameter 50. Check devices wired between TB13D and TB-2.
DB ERROR	Dynamic Brake fault: DB circuit has sensed a resistor overload.	The DB duty cycle is too high, causing the resistors to overheat.
CONTROL	Control Board fault: New software has been installed that is different from the previous version.	Perform a factory reset using Parameter 65-PROGRAM. This will update the software and allow the fault to be reset.
INTERNAL INTERN (#)	Internal fault: The micro-processor has sensed a problem.	Electrical noise on control wiring. Defective microprocessor.
FLWR / SER	Loss of Follower / Loss of Serial fault: 4-20 mA signal at TB-5B is below 2 mA, or if serial control, serial link was lost.	Parameter 55 - TB5B LOSS is set to FAULT. Parameter 56 - SERIAL LOSS is set to FAULT.
Blank Display or repeatedly flashes TESTING	The power supply has shut down. This can be the result of clogged or failed heatsink fans.	Check heatsink fans (if equipped). Clear any obstructions. If they are not clogged, contact the AC Tech Service Department.

APPENDIX A - MCH WITH BYPASS OPTION

A.1 MCH OPERATION WITH BYPASS

The MCH Series drive is available with a Bypass option that allows the motor to be operated at full speed from line power while the drive is being serviced. The Bypass option contains three contactors. Two are used to isolate the drive while in bypass mode. One isolates the drive from input power, and the other isolates the drive output from the motor. The third contactor is used to start the motor across line power.

The bypass option contains three selector switches, which are explained below:

HAND/OFF/AUTO - In HAND mode, the drive or bypass will start.

In AUTO mode, the drive or bypass will start when terminal B3 is closed to B4 on TB50. Drive or Bypass mode is selected using the DRIVE MODE/OFF/BYPASS MODE switch.

When configured with the Bypass option, the HAND (START), and AUTO (START) keys on the drive's keypad are disabled and cannot be used to start the drive. The OFF (STOP) key will still function to stop the drive.

If an MCH drive with bypass is running in drive mode, and is stopped using the OFF (STOP) key on the drive's keypad instead of the OFF position on the H/O/A selector switch, the drive cannot be started again until the HAND (START) or AUTO (START) key on the keypad is pressed to reset the OFF (STOP) command from the keypad.

DRIVE MODE/OFF/BYPASS MODE - In DRIVE MODE, the MCH drive controls the motor (the MCH input and output contactors are closed).

In BYPASS MODE, the bypass contactor is used to start and stop the motor (the MCH input and output contactors are open).

DRIVE TEST/OFF/DRIVE NORMAL - In DRIVE TEST mode, input power is applied to the drive for testing purposes, but the output contactor remains open to isolate the drive from the motor.

In DRIVE NORMAL mode, the input and output contactors are closed, allowing the drive to control the motor.

NOTE 1: If any of the three selector switches is in the OFF position, the motor cannot be operated.

NOTE 2: When the drive is equipped with the bypass option, motor rotation must be checked in both drive mode and bypass mode. Refer to NOTE 2 in Section 12 for the procedure for checking and correcting motor rotation.

A.2 BYPASS WIRING

MCH drives with the Bypass option do not have a terminal strip in the same location as a "standard" MCH drive. There is a customer terminal strip located in the Bypass compartment, eliminating the need to remove the drive cover. All customer wiring is done in the bypass compartment. These terminals are briefly described below:

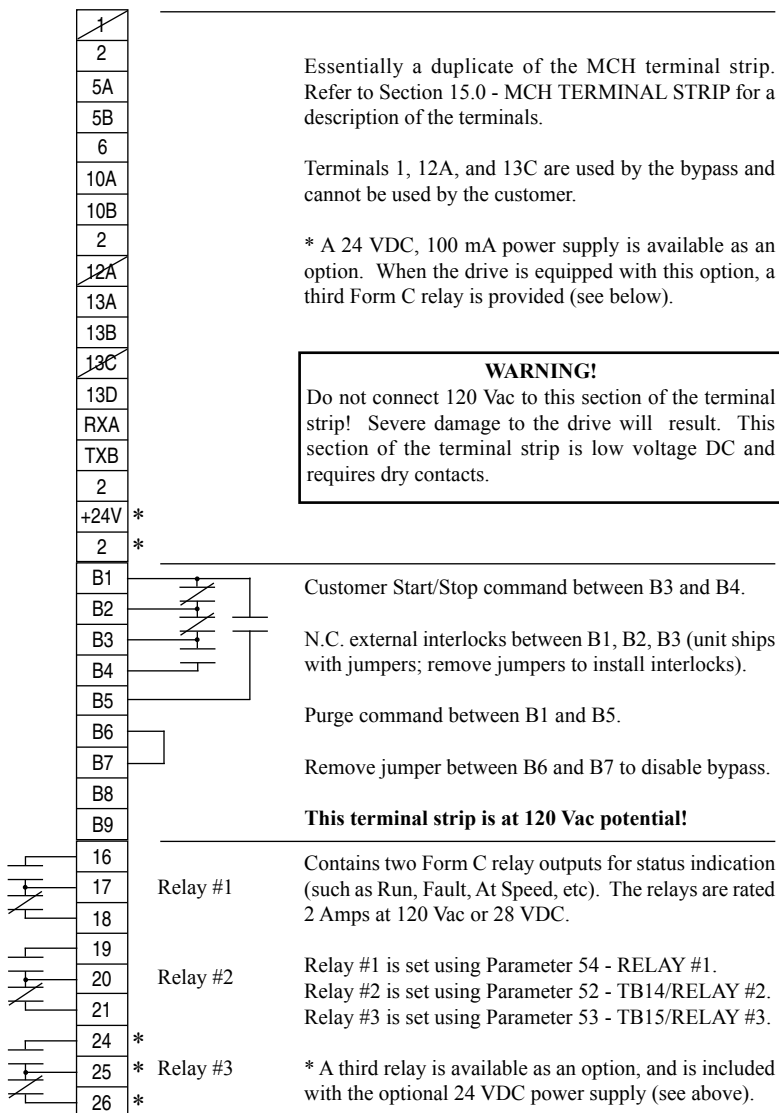

WARNING!

Do not connect 120 Vac to this section of the terminal strip! Severe damage to the drive will result. This section of the terminal strip is low voltage DC and requires dry contacts.

A.3 BYPASS SCHEMATIC

Below is a general schematic showing how the bypass option works with the MCH drive:

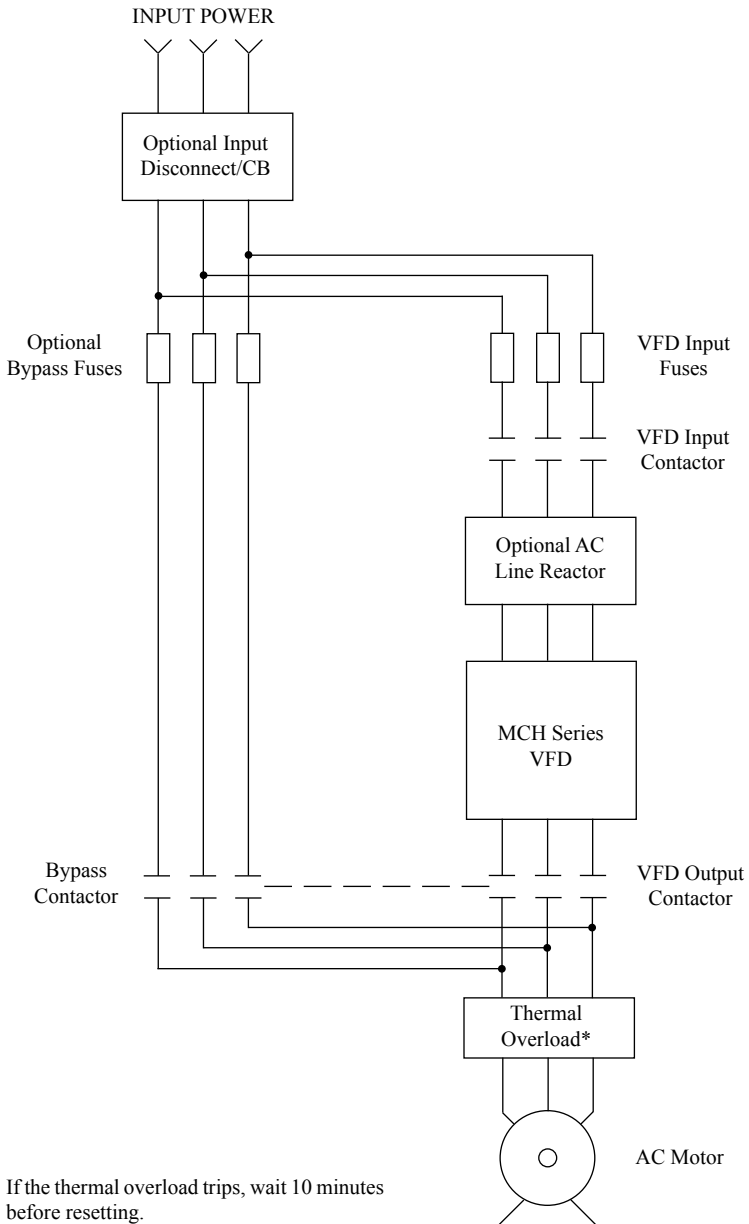

* If the thermal overload trips, wait 10 minutes before resetting.

APPENDIX B - MCH WITH OPTION BOX

The MCH Series drive is available with an Option Box that allows the drive to accommodate a disconnect switch, fuses, and line reactor. Like the Bypass option, the customer terminal strip is not located in the drive itself, but rather in the option box compartment, eliminating the need to remove the drive's cover. This simplifies installation by having all of the control and power wiring in one location.

B.1 CUSTOMER TERMINAL STRIP

1		
2		
5A		A duplicate of the MCH terminal strip. Refer to Section 15.0 - MCH TERMINAL STRIP for a description of the terminals.
5B		
6		
10A		* Terminal 14 and Relay #2 are both controlled by Parameter 52 - TB14/RELAY #2. TB-14 is an open-collector output, while Relay #2 is a Form C relay.
10B		
2		
12A		WARNING! Do not connect 120 Vac to this section of the terminal strip! Severe damage to the drive will result. This section of the terminal strip is low voltage DC and requires dry contacts.
13A		
13B		
13C		
13D		
14 *		
15		
2		
RXA		
TXB		
16		
17	Relay #1	Contains two Form C relay outputs for status indication (such as Run, Fault, At Speed, etc). The relays are rated 2 Amps at 120 Vac or 28 VDC.
18		
19		
20	Relay #2 *	Relay #1 is set using Parameter 54 - RELAY #1. Relay #2 is set using Parameter 52 - TB14/RELAY #2.
21		

NOTE: Unlike the Bypass option, which restricts the MCH drive to Remote H/O/A only, MCH drives with the Option Box can be configured for Keypad H/O/A or Remote H/O/A. Refer to Sections 13.1 and 14.2.

B.2 OPTION BOX SCHEMATIC

Below is a general schematic showing how the Option Box components are wired to the drive.

NOTE: If the Option Box does not contain a disconnect or fuses, terminals will be provided for the input power.

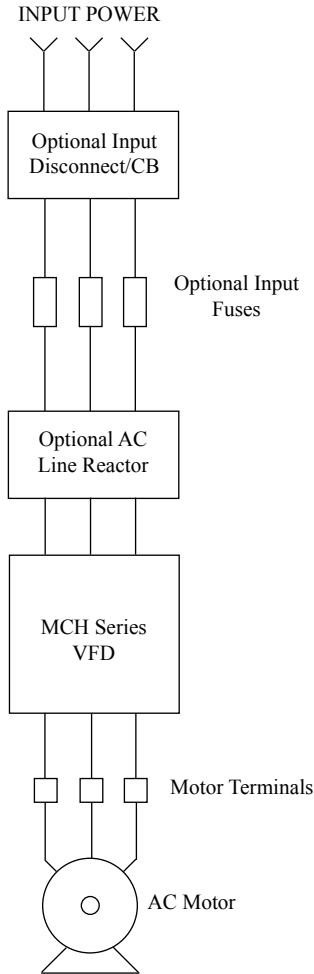

APPENDIX C - USER SETTING RECORD

PARAMETER MENU: USER SETTING RECORD			
PARAM. NUMBER	PARAMETER NAME	FACTORY DEFAULT	USER SETTING
0	LINE VOLTS	AUTO	
1	PRESET #1	20.00 Hz	
2	PRESET #2	20.00 Hz	
3	PRESET #3	20.00 Hz	
4	PRESET #4	20.00 Hz	
5	SKIP FREQ #1	.00 Hz	
6	SKIP FREQ #2	.00 Hz	
7	BANDWIDTH	1.00 Hz	
8	ACCEL RATE	30.0 SEC	
9	DECEL RATE	30.0 SEC	
10	MINIMUM FREQ	.50 Hz	
11	MAXIMUM FREQ	60.00 Hz	
12	DC BRAKE VOLT	.0 VDC	
13	DC BRAKE TIME	.0 SEC	
14	DYNAMIC BRAKE	OFF	
16	CURRENT LIMIT	120 %	
17	MOTOR OVRLOAD	100%	
18	BASE FREQ	60.00 Hz	
19	FIXED BOOST	(NOTE 1)	
22	TORQUE	CONSTANT	
23	CARRIER FREQ	2.5 kHz	
24	AUTO SOURCE	4-20 mA	

NOTE 1: REFER TO SECTION 18.0 - DESCRIPTION OF PARAMETERS.

PARAMETER MENU: USER SETTING RECORD

PARAM. NUMBER	PARAMETER NAME	FACTORY DEFAULT	USER SETTING
25	START METHOD	NORMAL	
26	STOP METHOD	COAST	
28	SPEED SRC KEY	ENABLED	
29	HAND SOURCE	KEYPAD	
30	CONTROL	NORMAL	
31	UNITS	speed: HERTZ	
32	HZ MULTIPLIER	1.00	
33	UNITS DECIMAL	XXXXX	
34	LOAD MULTIPLY	100%	
35	LCD CONTRAST	MED	
36	SLEEP THRSILD	.00 Hz	
37	SLEEP DELAY	30.0 SEC	
38	SLEEP BANDWID	0 %	
39	TB5 MIN FREQ	.00 Hz	
40	TB5 MAX FREQ	60.00 Hz	
41	AN INPUT FLTR	0.02 SEC	
42	TB10A OUTPUT	NONE	
43	TB10A SCALING	60.00 Hz	
44	TB10B OUTPUT	NONE	
45	TB10B SCALING	125%	
47	TB13A INPUT	NONE	
48	TB13B INPUT	NONE	
49	TB13C INPUT	NONE	
50	TB13D INPUT	EXTERN FAULT	
52	TB14/RELAY #2	NONE	

PARAMETER MENU: USER SETTING RECORD

PARAM. NUMBER	PARAMETER NAME	FACTORY DEFAULT	USER SETTING
53	TB15/RELAY #3	NONE	
54	RELAY #1	NONE	
55	TB5B LOSS	FAULT	
56	SERIAL LOSS	FAULT	
57	SERIAL COMM	DISABLED	
58	SERIAL ADDRES	30	
61	PASSWORD	0019	
63	SOFTWARE VERS	(N/A)	
64	MONITOR MODE	ON	
65	PROGRAM	RESET 60	
66	CLEAR HISTORY	MAINTAIN	
70	PID MODE	OFF	
74	PID FEEDBACK	TB-5A	
75	FEEDBACK @ MIN	0.00%	
76	FEEDBACK @ MAX	100.00%	
77	PROPOR. GAIN	5.00%	
78	INTEGRAL GAIN	0.0 SEC	
79	DIFF. GAIN	0.0 SEC	
80	PID ACCEL	30.0 SEC	
81	MIN ALARM	0.00%	
82	MAX ALARM	0.00%	
98	LANGUAGE	ENGLISH	
99	FAULT HISTORY	(N/A)	

NOTES

NOTES

NOTES

NOTES

NOTES

EC DECLARATION OF CONFORMITY

In accordance with EN45014:1998

Applied Council Directive(s): EMC Directive 89/336/EEC, as amended: 92/31/EEC and Low Voltage Directive 73/23/EEC, as amended: 93/68/EEC

We, Manufacturer:

AC Technology Corporation
660 Douglas Street
Uxbridge, MA 01569 U.S.A.

Authorized Representative:

AC Technology Europe
4 Shackleton Way
Bowbrook
Shrewsbury, Shropshire SY3 8SW U.K.

declare under our sole responsibility that the products to which this Declaration relates, are in conformity with the relevant provisions of the following standards, provided that installations are carried out in accordance with manufacturer's instructions.

PRODUCTS RELATED TO DECLARATION

MCH Series AC Variable Frequency Motor Drives:

MH200

MH400

MH500

RELEVANT EUROPEAN STANDARDS

EN 50081-2* Electromagnetic compatibility

– Generic emission standard – Part 2: Industrial environment

EN 50082-2* Electromagnetic compatibility

– Generic immunity standard – Part 2: Industrial environment

EN 50178:1998 Electronic equipment for use in power installations

* with suitable line filters that are properly installed.

YEAR OF CE Marking (Low Voltage Directive): 2000

Signature:



Jim Reinwald, Compliance Manager

Date:

17 June 2000

AC Technology Corporation

630 Douglas Street, Uxbridge MA 01569

Sales: 800 - 217 - 9100, FAX: 508 - 278 - 7873

Service: 508 - 278 - 9100 ext 125, FAX: 508 - 278 - 6620

www.actech.com

Document
MH01G-e1