

Comp-AC

User's Manual

ACS 100 AC Drives for
Speed Control of
 $\frac{1}{6}$ to 3 Hp (0.18 to 2.2 kW)
AC Induction Motors



ACS 100 AC Drives for Speed Control of AC Induction Motors

User's Manual

ACS100U-US-04
3AUA489002B3919 R0101 Rev. B
Effective: 8/1/00
Supersedes: 9/1/97

Safety



Warning! Only a competent electrician should install the ACS 100.



Warning! Dangerous voltages are present when input power supply is connected. Wait at least 5 minutes after disconnecting the supply before removing the cover. Measure the voltage at the DC terminals (U_{c+} , U_{c-}) before servicing the unit (see G).



Warning! Even when the motor is stopped there are dangerous voltages present at Power Circuit terminals U1, V1, W1 (L,N) and U2, V2, W2 and U_{c+} , U_{c-} .



Warning! Even when the ACS 100 is powered down, dangerous external voltages may be present at relay terminals RO1, RO2, RO3.



Warning! The ACS 100 is not a field repairable unit. Never attempt to repair a broken unit; contact your Authorized ABB Service Center for replacement.



Warning! The ACS 100 may start up automatically after an input voltage interruption if programmed for Automatic Restart after Power Outage.



Warning! When the control terminals of two or more ACS 100 / 140 / 400 units are connected in parallel, the auxiliary voltage for these control connections must be taken from a single source which can either be one of the units or an external supply.



Warning! Altering the parameter settings or device configurations will affect the function and performance of the ACS 100. Check that these changes do not cause any risk to persons or property.



Warning! The heat sink may reach a high temperature (see S).

Note! For more technical information, contact the factory or your local ABB Sales Representative.

Table of Contents

| | |
|---|-----------|
| Safety | i |
| Installation | 1 |
| Reference Sections | 2 |
| Environmental Limits | 2 |
| Dimensions in (mm) | 2 |
| Installing the ACS 100 | 3 |
| Removing the Cover | 6 |
| Attaching a Warning Sticker | 6 |
| Cable Connections | 6 |
| Terminal Interface | 7 |
| Type Designation Label and Code Key | 8 |
| Floating Network | 8 |
| Motor | 8 |
| Control Terminals | 9 |
| Configuration Switch | 10 |
| Connection Examples | 11 |
| Replacing the Cover | 11 |
| Power On | 12 |
| Protection Features | 12 |
| Motor Overload Protection | 13 |
| Loadability of ACS 100 | 13 |
| Type Series and Technical Data | 14 |
| Product Conformity | 17 |
| Environmental Information | 17 |
| Programming | 19 |
| Control Panel | 19 |
| Control Modes | 19 |
| Output Display | 20 |
| Menu Structure | 20 |
| Setting Parameter Value | 20 |
| Menu Functions | 21 |
| Diagnostic Displays | 21 |
| Resetting the Drive | 22 |

ACS 100 Parameter Table 23

- Group 01: Actual Values and Status 25
- Group 02: Motor Values and Limits..... 25
- Group 03: Drive Control 26
- Group 04: Input/Output..... 27
- Group 05: Supervision..... 28

Diagnostics 31

- General..... 31
- Alarm and Fault displays 31
- Fault Resetting 31

ACS 100 EMC Instructions 35

Installation

Study this manual carefully before proceeding. Failure to observe the warnings and instructions given may cause a malfunction or personal hazard.

- 1 CHECK the environment. See **A**
- 2 INSTALL the ACS 100. See **B, C**
- 3 REMOVE the cover. See **D**
- 4 ATTACH a warning sticker in the language of your choice. See **E**
- 5 IDENTIFY power and control terminals. See **F, G, K**
- 6 CHECK voltage supply. See **H, I**
- 7 CHECK the motor. See **J**
- 8 CHECK configuration switch S1. See **L**
- 9 CONNECT power terminals. See **F, G**
- 10 CONNECT control wires. See **G, K, M**
- 11 REPLACE the cover. See **N**
- 12 TURN the power on. See **O**

Reference Sections

A Environmental Limits

- Ambient operating temperature 32 - 104 °F (0 - 40 °C), 0 - 86 °F (0 - 30 °C) if $f_{sw} = 16$ kHz
- Max. ambient temperature 122 °F (50 °C) if P_N and I_2 derated to 80 % and $f_{sw} = 4$ kHz
- Installation altitude 0 - 3300 ft. (0 - 1000 m) if P_N and I_2 100 %.
- Installation altitude 0 - 6600 ft. (0 - 2000 m) if P_N and I_2 derated 1 % every 330 ft. (100 m) above 3300 ft. (1000 m).
- Relative humidity less than 95 % (non-condensing)
- Storage temperature - 40 - 158 °F (-40 °C - 70 °C)
- Transport temperature - 40 - 158 °F (-40 °C - 70 °C)

The ACS 100 should be installed in clean and dry air, free from dripping water, corrosive materials and electrically conductive dust (pollution degree 2). The installation room must be locked or tool-openable.

B Dimensions in (mm)

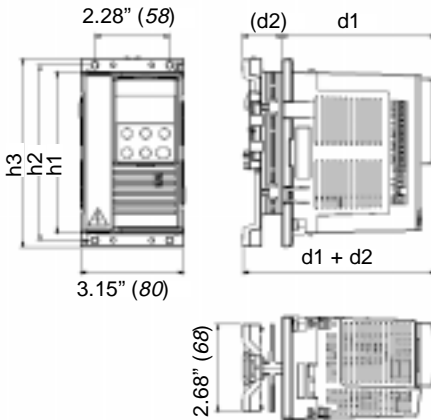

| Frame Size IP 20 | 200 V Series | | | | | | Weight (kg) | |
|---------------------|--------------|------------|------------|------------|-----------|------------|-------------|------------|
| | h1 | h2 | h3 | d1 | (d2) | d1+d2 | 1~ | 3~ |
| A | 4.96 (126) | 5.35 (136) | 5.75 (146) | 4.60 (117) | 1.25 (32) | 5.87 (149) | 1.98 (0.9) | 1.76 (0.8) |
| B | 4.96 (126) | 5.35 (136) | 5.75 (146) | 4.60 (117) | 1.72 (69) | 7.32 (186) | 2.65 (1.2) | 2.43 (1.1) |
| C | 7.80 (198) | 8.19 (208) | 8.58 (218) | 4.60 (117) | 2.05 (52) | 6.65 (169) | 3.53 (1.6) | 3.31 (1.5) |
| D | 8.86 (225) | 9.25 (235) | 9.65 (245) | 4.88 (124) | 2.05 (52) | 6.93 (176) | 4.19 (1.9) | 3.97 (1.8) |
| H | 4.96 (126) | 5.35 (136) | 5.75 (146) | 4.68 (119) | 0 | 4.68 (119) | 1.76 (0.8) | - |
| | 400 V Series | | | | | | | |
| A | 4.96 (126) | 5.35 (136) | 5.75 (146) | 4.60 (117) | 1.25 (32) | 5.87 (149) | - | 1.76 (0.8) |
| B | 4.96 (126) | 5.35 (136) | 5.75 (146) | 4.60 (117) | 1.72 (69) | 7.32 (186) | - | 2.43 (1.1) |
| C | 7.80 (198) | 8.19 (208) | 8.58 (218) | 4.60 (117) | 2.05 (52) | 6.65 (169) | - | 3.31 (1.5) |
| D | 8.86 (225) | 9.25 (235) | 9.65 (245) | 4.88 (124) | 2.05 (52) | 6.93 (176) | - | 3.97 (1.8) |
| H | 4.96 (126) | 5.35 (136) | 5.75 (146) | 4.68 (119) | 0 | 4.68 (119) | - | 1.54 (0.7) |

C Installing the ACS 100

 **Warning!** Before installing the ACS 100 ensure that the input power supply to the drive is off.

Standard Series (Frame sizes A, B, C and D)

Install the ACS 100 vertically. Leave 1" (25 mm) free space above and below the unit. Ensure that there is sufficient cool air in the cabinet to compensate for the power losses (power and control circuits) listed at the end of section S, "Technical Data".

Wall mounting

Screw in four (4) screws or affix nuts and bolts (Use the method appropriate for your mounting surface). Torque screws or bolts to 9 to 13 pound-inches (1 - 1.5 Nm).

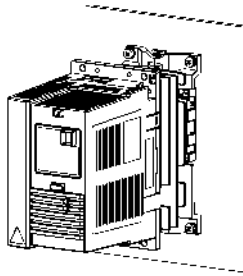

DIN rail (35 mm)

Press the lever on top of the unit while installing on / removing from DIN rail.

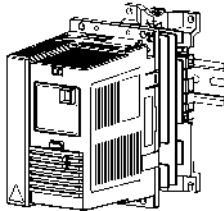

Flange mounting

The ACS 100 can be installed so that the heat sink is in an air duct. The power circuit losses will then be dissipated outside leaving only the control circuit losses to be dissipated inside (see S).

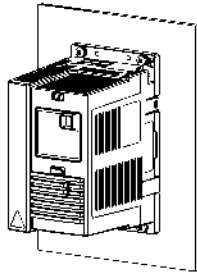

Heatsinkless series (Frame size H)



Note! The frame size H **does not include the heatsink**. The heatsinkless ACS 100 is intended for applications where an external heatsink is available. Ensure that the area of installation fulfils the heat dissipation requirements.

Mounting Surface Requirements

Install the heatsinkless ACS 100 on an uncoated, clean metallic surface that fulfils the following requirements:

- A minimum thickness of 0.12" (3 mm).
- The surface must be stiff and flat. (max. flatness error 0.1 and max. roughness R_a 3.2 μm)

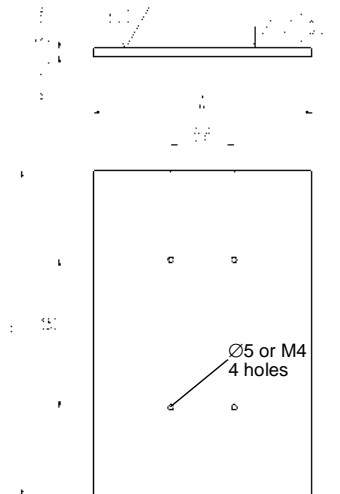

Heat Dissipation Requirements

Ensure that the mounting surface is capable of conducting power losses into the environment. The maximum temperature of the mounting plate may not exceed 176 °F (80 °C) under any circumstances.

The table below gives the power losses and minimum surface area requirements, when a 0.12" (3 mm) steel plate, capable of dissipating heat from both sides, is used as a heatsink (max. ambient temperature 104 °F (40 °C)). The 0.12" (3 mm) steel plate is only one example, any kind of external heatsink can be used if it meets the mounting surface and heat dissipation requirements.

| Converter Type | Power Loss (W) | Minimum Area H x W in x in (mm x mm) |
|----------------|----------------|---|
| ACS 101-H18-1 | 7 | 5.91" x 5.91" (150 x 150) |
| ACS 101-H25-1 | 10 | 7.09" x 7.09" (180 x 180) |
| ACS 101-H37-1 | 12 | 7.87" x 7.87" (200 x 200) |
| ACS 101-H75-1 | 13 | 8.27" x 8.27" (210 x 210) |
| ACS 101-1H1-1 | 19 | 9.84" x 9.84" (250 x 250) |
| ACS 101-1H6-1 | 27 | 11.81" x 11.81" (300 x 300) |

Mechanical Installation

- Clean the mounting surface.
- Apply thermal grease between the ACS 100 and the mounting surface.
- Screw in four screws or affix nuts and bolts (use the method appropriate for your mounting surface). Torque screws or bolts to 9 to 13 pound-inches (1 - 1.5 Nm).

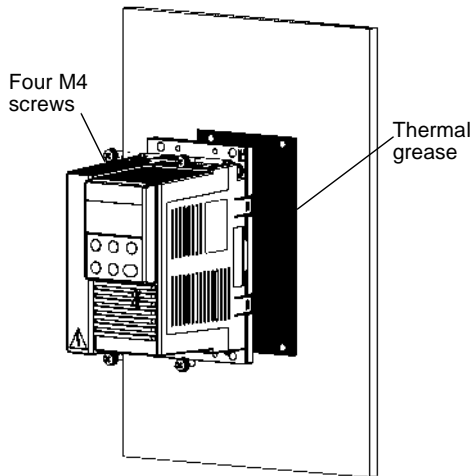

After installation, verify the thermal design by monitoring the temperature (parameter 104) of the ACS 100. The thermal design is successful if the ACS 100's temperature does not exceed 185 °F (85 °C) under full load and maximum ambient temperature.

D Removing the Cover

- 1 Press the four buttons on the top and bottom corners of the unit simultaneously.
- 2 Remove the cover.

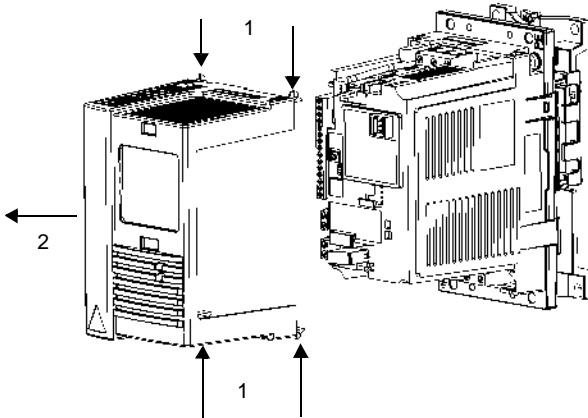

E Attaching a Warning Sticker

The packing box includes warning stickers in different languages. Attach a warning sticker in the language of your choice on the inside plastic skeleton as indicated, in section G, 'Terminal Interface'.

F Cable Connections

| Terminal | Description | Note |
|---|-----------------------|---|
| L, N | 1~ power supply input | see G. |
| U1, V1, W1 | 3~ power supply input | Do not use in 1~ supply! |
| PE | Protective Earth | Min. 4 mm ² Cu wire. |
| U2, V2, W2 | Power output to motor | Max. cable length depends on the unit type (see S). |
| Uc+, Uc- | DC bus voltage 325 V | For optional ACS braking unit/chopper |
|  | Motor cable shield | |

Follow local rules for cable cross-sections. Use shielded motor cable.
Route the motor cable away from control wires and the power supply cable to avoid electromagnetic interference.



Note! See EMC instructions on "ACS 100 EMC Instructions" on page 35.

G Terminal Interface

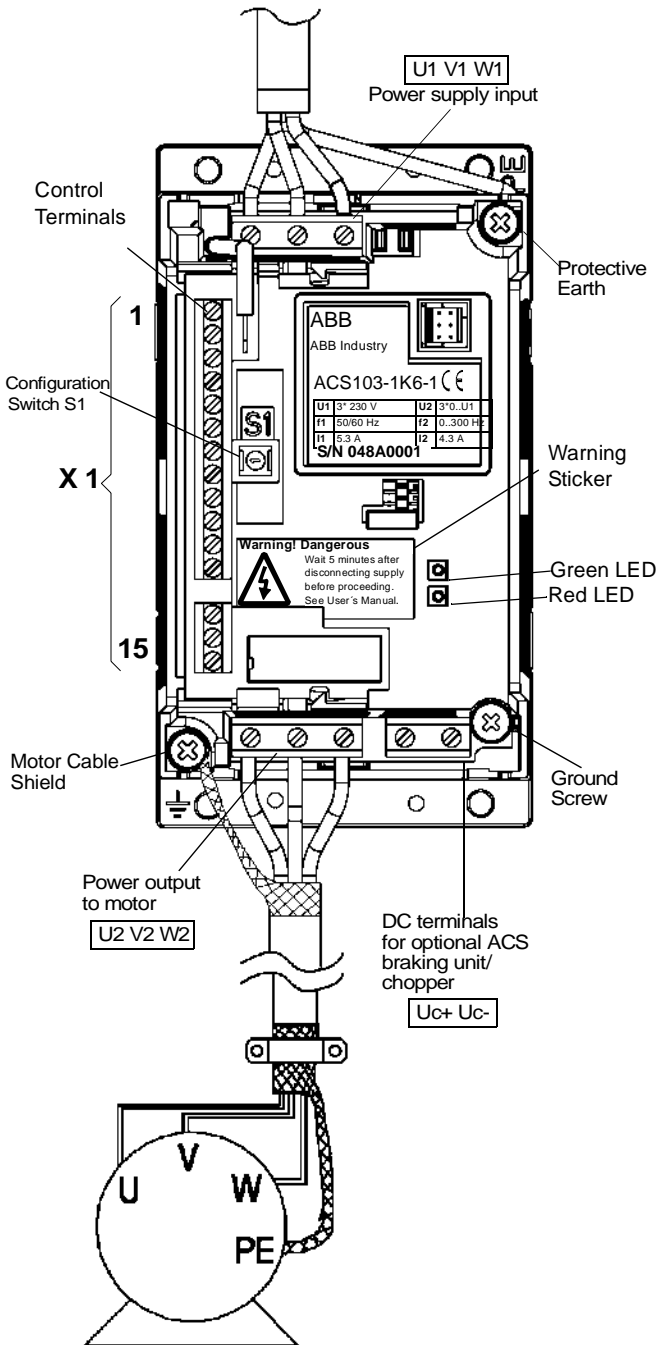

H Type Designation Label and Code Key

Supply:
ACS 101 = 1 ~
ACS 103 = 3 ~

Power:
1K6 = 1.6 kVA standard
series (frames A, B, C
and D)
1H6 = 1.6 kVA
heatsinkless series
(frame H)

| | | | |
|---------------------|----------|----|-----------|
| ABB | | | |
| ABB Industry Oy | | | |
| ACS103-1K6-1 | | | |
| | | CE | |
| U1 | 3* 230V | U2 | 3*0..U1 |
| f1 | 50/60 Hz | f2 | 0..300 Hz |
| I1 | 5.3 A | I2 | 4.3 A |
| S/N 048A0001 | | | |

Serial number:
S/N 048A0001
0= Year 2000
48 = Week 48
A0001=Internal
number

I Floating Network

If the supply network is floating (IT network), remove the grounding screw (GND).
Failure to do so may cause danger or damage the unit.

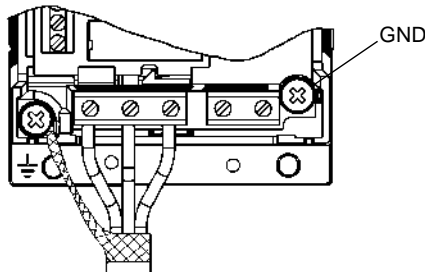

Do not use external RFI filters with floating networks. The input power becomes connected to ground through the filter capacitors which may cause a hazardous condition or damage to the drive.

Make sure that no excessive emission is propagated to neighboring low voltage networks. In some cases, the natural suppression in transformers and cables is sufficient. If in doubt, a supply transformer with static screening between the primary and secondary windings can be used.

J Motor

Check that the motor is compatible. The motor must be a three-phase induction motor, with U_N from 200 to 240 V and f_N either 50 Hz or 60 Hz. If the motor values differ from these, the group 02 parameter values must be changed.

The motor nominal current, I_N , must be less than or equal to the nominal output current of the ACS 100, I_2 (See H and S).

K Control Terminals

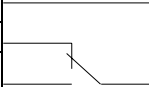
| X1 | Identification | Description | |
|-------------------------|----------------|--|--|
| 1 | SCR | Terminal for signal cable screen. (Connected internally to chassis ground.) | |
| 2 | AI | Analog input 0-10 V \Leftrightarrow 0- f_{nom} output frequency. $R_i = 190 \text{ k}\Omega$ (0-10 V signal) / 500Ω (0-20 mA signal). Resolution 0.1 % accuracy ± 1 %. | |
| 3 | AGND | Analog input circuit common. (Connected internally to chassis ground through $1 \text{ M}\Omega$) | |
| 4 | 10 V | 10 V reference voltage output for analog input potentiometer, accuracy ± 2 %, 10 mA. | |
| 5 | All | Analog input AI can be configured to accept 0- 20 mA signal by shorting terminals 5 and 6. Then $R_i = 500 \Omega$. | |
| 6 | AGND | Terminals for DI return wires. | |
| 7 | AGND | | |
| 8 | 12 V | Aux. voltage output 12 V DC. $I_{max} = 100 \text{ mA}$ (reference to AGND). Short circuit protected. | |
| 9 | DCOM | Digital input common. To activate a digital input, there must be +12 V (or -12 V) between that input and DCOM. The 12 V may be provided by the ACS 100 (X1:8) as in the connection examples (see M) or from an external 12-24 V source of either polarity. | |
| DI Configuration | | ABB Standard ($f_{nom} = 50 \text{ Hz}$) $S1 = \{0;1;2;3;4\}$. See L | 3-wire ($f_{nom} = 60 \text{ Hz}$) $S1 = \{5;6;7;8;9\}$. See L |
| 10 | DI 1 | Start. Activate to start. Motor will ramp up to frequency reference. Disconnect to stop. Motor will coast to stop. | Start. If DI 2 is activated, momentary activation of DI 1 starts the ACS 100. |
| 11 | DI 2 | Reverse. Activate to reverse rotation direction. | Stop. Momentary inactivation always stops the ACS 100. |
| 12 | DI 3 | Jog. Activate to set output frequency to constantspeed default 5 Hz, see parameter 406. | Reverse. Activate to reverse rotation direction. |
| 13 | RO 1 |  | Fault relay output Fault: RO 1 and RO 2 connected. 12 V-250 V AC/ 30 V DC 10 mA - 2 A |
| 14 | RO 2 | | |
| 15 | RO 3 | | |

DI configuration can be modified with parameter 405 or, if the control panel is not available, with configuration switch S1 (see **L**).

Digital input impedance $1.5 \text{ k}\Omega$.

Use multi-strand $0.5\text{-}1.5 \text{ mm}^2$ wire.

Note! For fail safe reasons the fault relay signals a “fault”, when the ACS 100 is powered down.

L Configuration Switch

The ACS 100 can be configured by using a configuration switch or a control panel. **When the control panel is used, S1 must be set to 0.**

The position of the configuration switch S1 determines:

- the nominal frequency f_{nom} (set to motor f_N)
- the acceleration and deceleration ramp time
- the I/O configuration of digital inputs (See **M**)

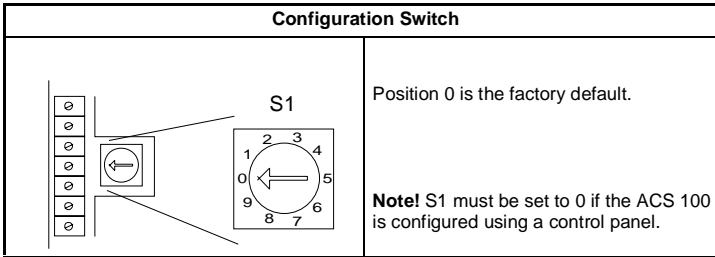

When setting the position of S1, first ascertain the motor nominal frequency f_N and then select the desired ramp time.

The configuration of digital inputs (DI) is dependent on the nominal frequency f_{nom} .

| f_{nom} | Ramp Time 0 - f_{nom} | S1-position | DI Configuration |
|-----------|----------------------------|-------------|------------------|
| 50 Hz | 5 s | 0 | ABB standard |
| | 1 s | 1 | |
| | 10 s | 2 | |
| | 30 s | 3 | |
| | 60 s | 4 | |
| 60 Hz | 1 s | 5 | 3-wire |
| | 5 s | 6 | |
| | 10 s | 7 | |
| | 30 s | 8 | |
| | 60 s | 9 | |

Note! The ACS 100 reads the position of the configuration switch during power up. Never set S1 when power is already applied to the ACS 100.

M Connection Examples

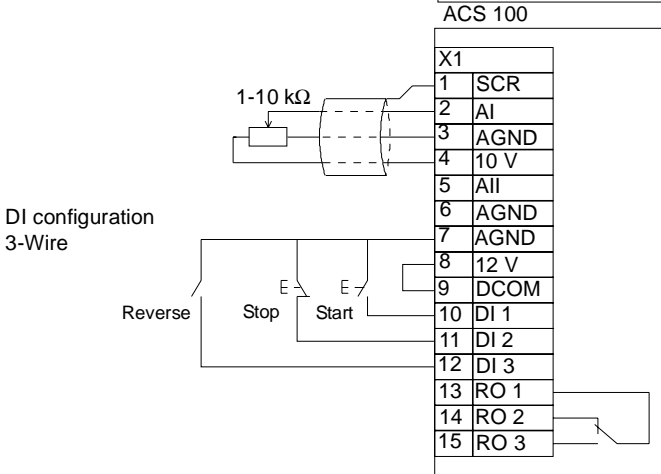
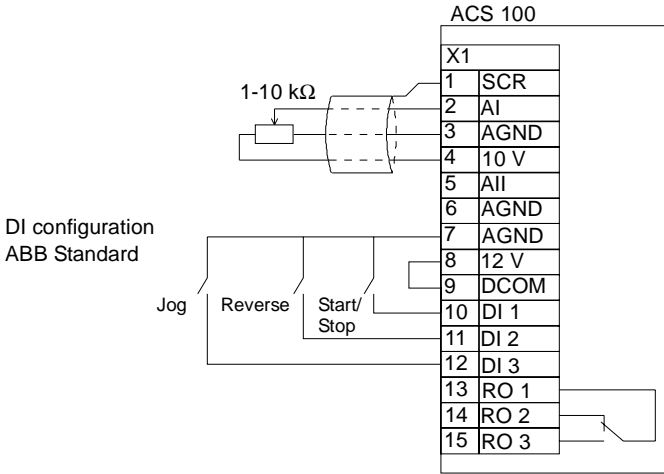

Frequency Reference from a Current Source

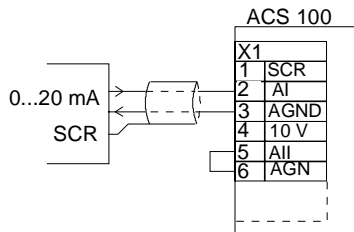

N Replacing the Cover

Do not turn the power on before replacing the cover.

O Power On

When power is supplied to the ACS 100, the green LED is illuminated.

P Protection Features

The ACS 100 has a number of protective features:

- Overcurrent
- Overvoltage
- Undervoltage
- Overtemperature
- Output ground fault
- Output short circuit
- Input phase loss (3~)
- Power loss ride through (500 ms)
- I/O terminal short circuit protection
- Long-term overcurrent limit trip 110 %
- Short-term current limit 150 %
- Motor overload protection (see **Q**)

The ACS 100 has the following LED alarm and fault indicators (for location of LED alarm indicators, see section G).

If the ACS 100-PAN control panel is connected, see “Diagnostics” on page 31.

| | |
|--|--|
| Red LED: off Green LED: blinking | |
| ABNORMAL CONDITION: <ul style="list-style-type: none"> • ACS 100 cannot fully follow control commands. • Blinking lasts 15 seconds. | POSSIBLE CAUSES: <ul style="list-style-type: none"> • Acceleration or deceleration ramp is too fast in relation to load torque requirement. • A short voltage interruption. |

| | |
|---|--|
| Red LED: on Green LED: on | |
| ACTION: <ul style="list-style-type: none"> • Give a stop signal to reset fault. • Give a start signal to restart the drive. NOTE: If the drive fails to start, check that the input voltage is within the tolerance range, (200...240 V ±10 %). | POSSIBLE CAUSES: <ul style="list-style-type: none"> • Transient overcurrent • Over-/undervoltage • Overtemperature CHECK: <ul style="list-style-type: none"> • the supply line for phase loss or disturbances. • the drive for mechanical problems that might cause overcurrent. • that heat sink is clean. |

| | |
|--|---|
| Red LED: blinking Green LED: on | |
| ACTION: <ul style="list-style-type: none"> • Turn the power off. • Wait for the LEDs to turn off. • Turn the power back on. Caution! This action may start the drive. | POSSIBLE CAUSE: <ul style="list-style-type: none"> • Output ground fault • Short circuit CHECK: <ul style="list-style-type: none"> • The insulation of the motor circuit. |

Note! Whenever the ACS 100 detects a fault condition, the fault relay activates. The motor will coast to stop and the ACS 100 will wait to be reset. If the fault still persists and no external cause has been identified, contact the factory or your local Authorized ABB Drives Distributor.

Q Motor Overload Protection

If the motor current I_{out} exceeds the nominal current I_{nom} of the motor (parameter 203) for a prolonged period of time, the ACS 100 automatically protects the motor from overheating by tripping.

Trip time depends on the extent of the overload (I_{out} / I_{nom}), the output frequency and nominal motor frequency f_{nom} . Times given apply to a "cold start".

ACS 100 provides overload protection in accordance with UL 508C. The default setting of motor thermal protection is **ON**. For more information, see parameter 502 on page 28.

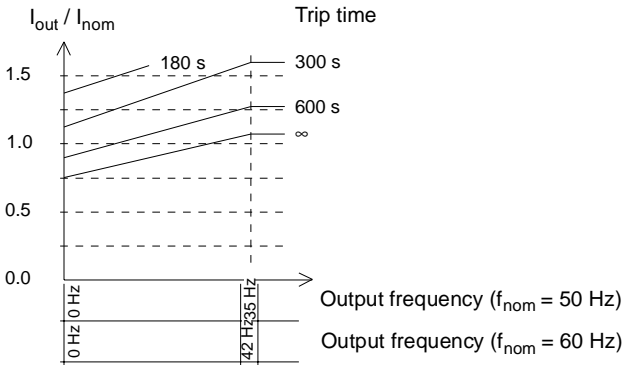

R Loadability of ACS 100

In the event of an output overload, the ACS 100 will trip.

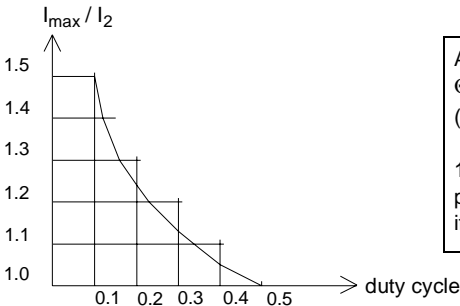
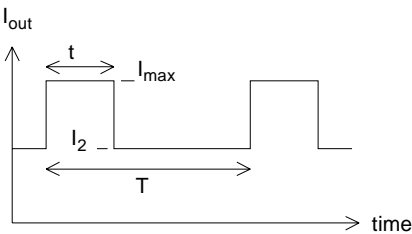

S Type Series and Technical Data

| Standard series | | | | | | |
|--|-----------------|--|-------|-------|-------|-------|
| Nominal motor P _N | kW | 0.12 | 0.18 | 0.25 | 0.37 | 0.55 |
| 1~ Input | ACS101- | K18-1 | K25-1 | K37-1 | K75-1 | 1K1-1 |
| 3~ Input | ACS103- | - | - | - | K75-1 | 1K1-1 |
| Frame size | | A | | | | |
| Nominal Ratings (See H, P) | Unit | | | | | |
| Input voltage U ₁ | V | 200 V-240 V ±10 % 50/60 Hz (ACS 101: 1~, ACS 103: 3~) | | | | |
| Continuous output current I ₂ (4 kHz) | A | 1.0 | 1.4 | 1.7 | 2.2 | 3.0 |
| Continuous output current I ₂ (8 kHz) | A | 0.9 | 1.3 | 1.5 | 2.0 | 2.7 |
| Continuous output current I ₂ (16 kHz) | A | 0.8 | 1.1 | 1.3 | 1.7 | 2.3 |
| Max. output current I _{2 max} (4 kHz) | A | 1.5 | 2.1 | 2.6 | 3.3 | 4.5 |
| Max. output current I _{2 max} (8 kHz) | A | 1.4 | 2.0 | 2.3 | 3.0 | 4.1 |
| Max. output current I _{2 max} (16 kHz) | A | 1.1 | 1.5 | 1.9 | 2.4 | 3.3 |
| Output voltage U ₂ | V | 0 - U ₁ 3~ | | | | |
| Input current I ₁ 1~ | A | 2.7 | 4.4 | 5.4 | 6.9 | 9.0 |
| Input current I ₁ 3~ | A | - | - | - | 3.2 | 4.2 |
| Switching frequency | kHz | 4 (Standard) 8 (Low noise *) 16 (Silent **) | | | | |
| Protection limits | (See P) | | | | | |
| Overcurrent (peak) | A | 3.2 | 4.5 | 5.5 | 7.1 | 9.7 |
| Overvoltage: Trip limit | V DC | 420 (corresponds to 295 V input) | | | | |
| Undervoltage: Trip limit | V DC | 200 (corresponds to 142 V input) | | | | |
| Overtemperature | °F (°C) | 194 (90) (heat sink) | | | | |
| Max. wire sizes | | | | | | |
| Max. motor cable length | m | 50 | 50 | 50 | 75 | 75 |
| Power terminals | mm ² | 4 single core / Torque 0.8 Nm | | | | |
| Control terminals | mm ² | 0.5 - 1.5 (AWG22...AWG16) / Torque 0.4 Nm | | | | |
| Line fuse 1~ ACS101- *** | A | 6 | 6 | 10 | 10 | 10 |
| Line fuse 3~ ACS103- *** | A | - | - | - | 6 | 6 |
| Power losses | | | | | | |
| Power circuit | W | 7 | 10 | 12 | 13 | 19 |
| Control circuit | W | 8 | 10 | 12 | 14 | 16 |

* Derate ambient temperature to 86 °F (30 °C) or derate P_N and I₂ to 90 % (see I₂ (8 kHz)).

** Derate ambient temperature to 86 °F (30 °C) and derate P_N and I₂ to 75 % (see I₂ (16 kHz)).

*** Fuse type: UL class CC or T (symbol KTK-R, JJN or JJS). For non-UL installations IEC269 gG. Use 140 °F (60 °C) rated power cable (167 °F (75 °C) if T_{amb} above 113 °F (45 °C)).

| Standard series | | | | | | |
|---|-----------------|--|-------------------------|-------|-------|--|
| Nominal motor P _N | kW | 0.75 | 1.1 | 1.5 | 2.2 | |
| 1~ Input | ACS101- | 1K6-1 | 2K1-1 | 2K7-1 | 4K1-1 | |
| 3~ Input | ACS103- | 1K6-1 | 2K1-1 | 2K7-1 | 4K1-1 | |
| Frame size | | B | C | | D | |
| Nominal Ratings (See H, P) | Unit | | | | | |
| Input voltage U ₁ | V | 200 V-240 V ±10 % 50/60 Hz (ACS 101: 1~, ACS 103: 3~) | | | | |
| Continuous output current I ₂ (4 kHz) | A | 4.3 | 5.9 | 7.0 | 9.0 | |
| Continuous output current I ₂ (8 kHz) | A | 3.9 | 5.3 | 6.3 | 8.1 | |
| Continuous output current I ₂ (16 kHz) | A | 3.2 | 4.4 | 5.3 | 6.8 | |
| Max. output current I _{2 max} (4 kHz) | A | 6.5 | 8.9 | 10.5 | 13.5 | |
| Max. output current I _{2 max} (8 kHz) | A | 5.9 | 8.0 | 9.5 | 12.2 | |
| Max. output current I _{2 max} (16 kHz) | A | 4.7 | 6.5 | 7.7 | 9.9 | |
| Output voltage U ₂ | V | 0 - U ₁ 3~ | | | | |
| Input current I ₁ 1~ | A | 10.8 | 14.8 | 18.2 | 22.0 | |
| Input current I ₁ 3~ | A | 5.3 | 7.2 | 8.9 | 12.0 | |
| Switching frequency | kHz | 4 (Standard) 8 (Low noise *) 16 (Silent **) | | | | |
| Protection limits | (See P) | | | | | |
| Overcurrent (peak) | A | 13.8 | 19.0 | 23.5 | 34.5 | |
| Overvoltage: Trip limit | V DC | 420 (corresponds to 295 V input) | | | | |
| Undervoltage: Trip limit | V DC | 200 (corresponds to 142 V input) | | | | |
| Overtemperature | °F (°C) | 194 (90) (heat sink) | 203 (95) (heat sink) | | | |
| Max. wire sizes | | | | | | |
| Max. motor cable length | m | 75 | 75 | 75 | 75 | |
| Power terminals | mm ² | 4 single core / Torque 0.8 Nm | | | | |
| Control terminals | mm ² | 0.5 - 1.5 (AWG22...AWG16) / Torque 0.4 Nm | | | | |
| Line fuse 1~ ACS101- *** | A | 16 | 16 | 20 | 25 | |
| Line fuse 3~ ACS103- *** | A | 6 | 10 | 10 | 16 | |
| Power losses | | | | | | |
| Power circuit | W | 27 | 39 | 48 | 70 | |
| Control circuit | W | 17 | 18 | 19 | 20 | |

* Derate ambient temperature to 86 °F (30 °C) or derate P_N and I₂ to 90 % (see I₂ (8 kHz)).

** Derate ambient temperature to 86 °F (30 °C) and derate P_N and I₂ to 75 % (see I₂ (16 kHz)).

*** Fuse type: UL class CC or T (symbol KTK-R, JJN or JJS). For non-UL installations IEC269 gG. Use 140 °F (60 °C) rated power cable (167 °F (75 °C) if T_{amb} above 113 °F (45 °C)).

| Heatsinkless series | | | | | | | |
|--|-----------------|---|-------|-------|-------|-------|-------|
| Nominal motor P _N | kW | 0.12 | 0.18 | 0.25 | 0.37 | 0.55 | 0.75 |
| 1~ Input | ACS101- | H18-1 | H25-1 | H37-1 | H75-1 | 1H1-1 | 1H6-1 |
| Frame size | | H | | | | | |
| Nominal ratings (See H, P) | Unit | | | | | | |
| Input voltage U ₁ | V | 200V - 240V ±10 % 50/60 Hz (ACS 101:1~) | | | | | |
| Continuous output current I ₂ (4 kHz) | A | 1.0 | 1.4 | 1.7 | 2.2 | 3.0 | 4.3 |
| Continuous output current I ₂ (8 kHz) | A | 0.9 | 1.3 | 1.5 | 2.0 | 2.7 | 3.9 |
| Continuous output current I ₂ (16 kHz) | A | 0.8 | 1.1 | 1.3 | 1.7 | 2.3 | 3.2 |
| Max. output current I _{2 max} (4 kHz) | A | 1.5 | 2.1 | 2.6 | 3.3 | 4.5 | 6.5 |
| Max. output current I _{2 max} (8 kHz) | A | 1.4 | 2.0 | 2.3 | 3.0 | 4.1 | 5.9 |
| Max. output current I _{2 max} (16 kHz) | A | 1.1 | 1.5 | 1.9 | 2.4 | 3.3 | 4.7 |
| Output voltage U ₂ | V | 0 - U ₁ 3~ | | | | | |
| Input current I ₁ 1~ | A | 2.7 | 4.4 | 5.4 | 6.9 | 9.0 | 10.8 |
| Switching frequency | kHz | 4 (Standard) 8 (Low noise *) 16 (Silent **) | | | | | |
| Protection limits | (See P) | | | | | | |
| Overcurrent (peak) | A | 3.2 | 4.5 | 5.5 | 7.1 | 9.7 | 13.8 |
| Overvoltage: Trip limit | V DC | 420 (corresponds to 295 V input) | | | | | |
| Undervoltage: Trip limit | V DC | 200 (corresponds to 142 V input) | | | | | |
| Overtemperature | °F (°C) | 194 (90) (heat sink) | | | | | |
| Max. wire sizes | | | | | | | |
| Max. motor cable length | m | 50 | 50 | 50 | 75 | 75 | 75 |
| Power terminals | mm ² | 4 single core / torque 0.8 Nm | | | | | |
| Control terminals | mm ² | 0.5 - 1.5 (AWG22...AWG16) / torque 0.4 Nm | | | | | |
| Line fuse 1~ *** ACS101- | A | 6 | 6 | 10 | 10 | 10 | 16 |
| Power losses | | | | | | | |
| Power circuit | W | 7 | 10 | 12 | 13 | 19 | 27 |
| Control circuit | W | 8 | 10 | 12 | 14 | 16 | 17 |

* Derate ambient temperature to 86 °F (30 °C) or derate P_N and I₂ to 90 % (see I₂ (8 kHz)).

** Derate ambient temperature to 86 °F (30 °C) and derate P_N and I₂ to 75 % (see I₂ (16 kHz)).

*** Fuse type: UL class CC or T (symbol KTK-R, JLN or JJS). For non-UL installations IEC269 gG. Use 140 °F (60 °C) rated power cable (167 °F (75 °C) if T_{amb} above 113 °F (45 °C)).

T Product Conformity

CE Marking

The ACS 100 complies with the requirements of the European

- Low Voltage Directive 73/23/EEC with amendments
- EMC Directive 89/336/EEC with amendments

Corresponding declarations and a list of main standards are available on request.



Note! See "ACS 100 EMC Instructions" on page 35.

A frequency converter and a Complete Drive Module (CDM) or a Basic Drive Module (BDM), as defined in IEC 61800-2, is not considered as a safety related device mentioned in the Machinery Directive and related harmonized standards. The CDM/BDM/frequency converter can be considered as a part of a safety device if the specific function of the CDM/BDM/frequency converter fulfils the requirements of the particular safety standard. The specific function of the CDM/BDM/frequency converter and the related safety standard is mentioned in the documentation of the equipment.

UL, ULc and C-Tick Markings

| | Frame size | UL | ULc | C-Tick |
|---------|------------|----------|----------|---------|
| ACS 100 | A | approved | approved | pending |
| ACS 100 | B | approved | approved | pending |
| ACS 100 | C | approved | approved | pending |
| ACS 100 | D | approved | approved | pending |
| ACS 100 | H | pending | pending | pending |

The ACS 100 is designed for use on a circuit capable of delivering no more than 65 kA.

U Environmental Information

A product to be disposed of contains valuable raw material that should be recycled, thus preserving energy and natural resources. Instructions for disposal are available from ABB sales and service companies.

Programming

Control Panel

This section of the manual provides information on how to use the ACS 100-PAN control panel with an ACS 100 drive.

The control panel can be connected to and detached from the drive at any time. The panel can be used to copy parameters to other ACS 100 drives with the same software revision (parameter 103).

When the control panel is powered up, the LCD display illuminates for one second. Immediately afterwards, the position of the configuration switch, S1, is displayed for one second, e.g. **CF 0**, when S1 = 0.

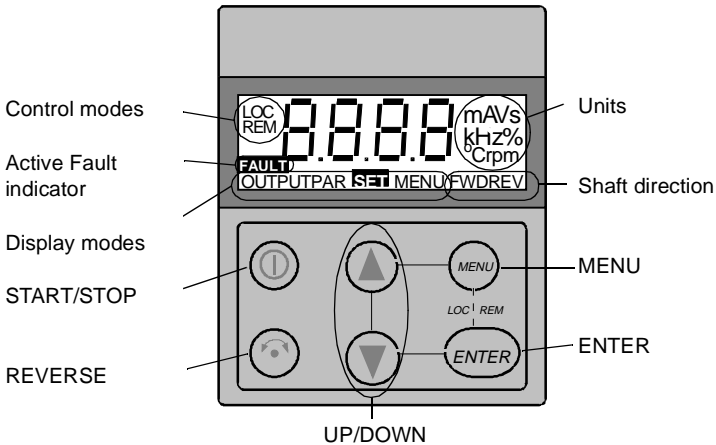

Control Modes

The very first time the drive is powered up, it is controlled from terminal X1 (remote control, **REM**). The ACS 100 is controlled from the control panel when the drive is in local control (**LOC**).

Switch to local control (**LOC**) by pressing and holding the MENU and ENTER buttons down simultaneously until first **Loc** or later **LCr** is displayed:

- If the buttons are released while **Loc** is displayed, the panel frequency reference is set to the current external reference and the drive is stopped.
- When **LCr** is displayed, the current run/stop status and the frequency reference are copied from the user I/O.

Start and stop the drive by pressing the START/STOP button.

Change the shaft direction by pressing the REVERSE button.

Switch back to remote control (**REM**) by pressing and holding the MENU and ENTER buttons down simultaneously until **rE** is displayed.

Shaft Direction

| | |
|-----------------------------------|---|
| FWD / REV Visible | <ul style="list-style-type: none"> • Shaft direction is forward / reverse • Drive is running and at set point |
| FWD / REV Blinking rapidly | Drive is accelerating / decelerating. |
| FWD / REV Blinking slowly | Drive is stopped. |

Output Display

When the control panel is powered up, the panel displays the actual output frequency. Whenever the MENU button is pressed and held, the control panel resumes this **OUTPUT** display.

To toggle between output frequency and output current, press the UP or DOWN button.

To set the output frequency in local control mode (**LOC**), press ENTER. Pressing the UP/DOWN buttons changes the output immediately. Press ENTER again to return to **OUTPUT** display.

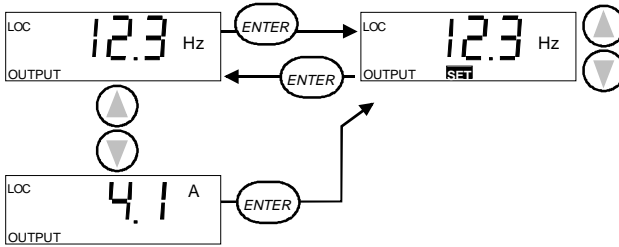

Menu Structure

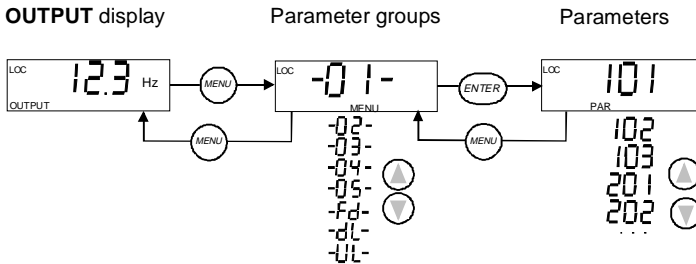

Setting Parameter Value

Press ENTER to view the parameter value.

To set a new value, press and hold ENTER until **SET** is displayed.

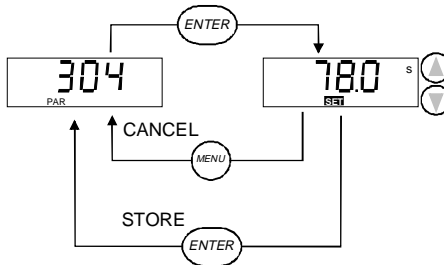

Note! **SET** blinks if the parameter value is altered. **SET** is not displayed if the value cannot be altered.

Note! To view the parameter default value press UP/DOWN buttons simultaneously.

Menu Functions

Scroll the Parameter groups for the desired Menu Function. Press and hold ENTER until the display blinks to start the function.

Note! Factory default settings and parameter copying does not affect all parameters. The excluded parameters are: 201 (Nom Volt), 202 (Nom Freq), 203 (Nom Curr), 204 (Nom Speed), and 503 (Param Lock). See ACS 100 Parameter Table for a description of these parameters.

Note! Drive must be stopped and in local control. The configuration switch, S1, must be set to 0. Parameter 503 (Param Lock) must be set to 1.

Restore factory defaults

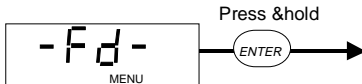

Parameter 503 (Param Lock) can also be set to 2.

Copy parameters from panel to drive (download)

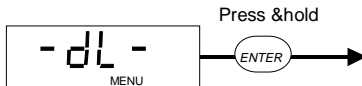

Copy parameters from drive to panel (upload)

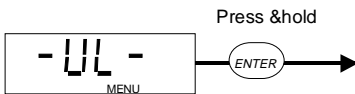

Diagnostic Displays

When the red LED of the ACS 100 is on or blinking, a fault is active. The relevant fault message flashes in the panel display.

When the green LED of the ACS 100 is blinking, an alarm is active. The relevant alarm message is shown in the panel display. Alarms 1-6 arise from button operation and the green LED does not blink for them.

The alarm and fault messages disappear by pressing MENU, ENTER or the arrow buttons of the control panel. The message will reappear after a few seconds if the keypad is not touched and an alarm or fault is still active.

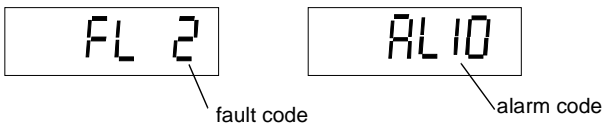

Refer to the Diagnostics section for a complete list of alarms and faults.

Resetting the Drive

When the red LED of the ACS 100 is on, or blinking, there is an active fault.

To reset a fault when the red LED is on, press the START/STOP button.

Caution! When in remote control, this may start the drive.

To reset a fault when the red LED is blinking, turn the power off.

Caution! Turning the power on again may start the drive immediately.

The relevant fault code (see Diagnostics) flashes in the panel display until the fault is reset or the display is “cleared”.

You can “clear” the display without resetting the fault by pressing any button. The word FAULT will be visible in the display.

Note! If no other button is pressed within 15 seconds and the fault is still active, the fault code will be displayed again.

After a power failure, the drive will be in the same control mode (**LOC** or **REM**) as before the power failure.

ACS 100 Parameter Table

S = Value can be modified only when Configuration switch, S1 = 0.

N = Not changeable when start is active.

| Code | Name | Min. | Max. | Resolution | Default | User | S | N |
|---------------------------------|---------------------------|----------------------|----------------------|---------------------------|--------------------|------|---|---|
| Group 01 | | | | | | | | |
| ACTUAL VALUES AND STATUS | | | | | | | | |
| 101 | Ref Freq | 0 Hz | 300 Hz | 0.1 Hz | - | | | |
| 102 | Last Fault | - | - | - | 0 | | | |
| 103 | Version | 0.0.0.0 | 9.9.9.F | - | - | | | |
| 104 | Temp | 0 °C | 150 °C | 0.1 °C | - | | | |
| Group 02 | | | | | | | | |
| MOTOR VALUES AND LIMITS | | | | | | | | |
| 201 | Nom Volt | 200 V | 240 V | 200, 208, 220, 230, 240 V | 230 V | | | ✓ |
| 202 | Nom Freq | 50 Hz | 300 Hz | 1 Hz | 60 Hz | | ✓ | ✓ |
| 203 | Nom Curr | 0.5 x I ₂ | 1.5 x I ₂ | 0.1 A | I ₂ | | | ✓ |
| 204 | Nom Speed | 0 rpm | 3600 rpm | 1 rpm | 1750 rpm | | | ✓ |
| 205 | Max Curr | 0.5 x I ₂ | 1.5 x I ₂ | 0.1 A | 1.5*I ₂ | | | |
| 206 | Max Freq | 0 Hz | 300 Hz | 1 Hz | 60 Hz | | ✓ | ✓ |
| 207 | Min Freq | 0 Hz | 300 Hz | 1 Hz | 0 Hz | | | |
| 208 | Dir Lock | 1 | 2 | - | 1 | | | |
| 209 | Motor Noise | 0 | 2 | - | 0 | | | ✓ |
| Group 03 | | | | | | | | |
| DRIVE CONTROL | | | | | | | | |
| 301 | Stop | 1 | 2 | - | 1 | | | |
| 302 | Ramp | 0 | 3 | - | 0 | | | |
| 303 | Acc | 0.1 s | 1800 s | 0.1 s; 1.0 s | 5.0 s | | ✓ | |
| 304 | Dec | 0.1 s | 1800 s | 0.1 s; 1.0 s | 5.0 s | | ✓ | |
| 305 | U/f Ratio | 1 | 2 | - | 1 | | | ✓ |
| 306 | IR Comp | 0 V | 30 V | 1 V | 10 V | | | |
| 307 | DC Inj Time | 0 s | 250 s | 0.1 s; 1.0 s | 0.0 s | | | |
| 308 | UC _{max} Control | 0 | 1 | - | 1 | | | |
| Group 04: | | | | | | | | |
| INPUT/ OUTPUT | | | | | | | | |
| 401 | AI min | 0 % | 100 % | 1 % | 0 % | | | |
| 402 | AI max | 0 % | 100 % | 1 % | 100 % | | | |
| 403 | Ref min | 0 Hz | 300 Hz | 1 Hz | 0 Hz | | | |
| 404 | Ref max | 0 Hz | 300 Hz | 1 Hz | 60 Hz | | ✓ | |
| 405 | DI Config | 1 | 3 | - | 1 | | ✓ | ✓ |
| 406 | Const Speed | 0 Hz | 300 Hz | 0.1 Hz | 5 Hz | | | |
| Group 05: | | | | | | | | |
| SUPERVISION | | | | | | | | |
| 501 | AI Fault | 0 | 1 | - | 0 | | | |

| Code | Name | Min. | Max. | Resolution | Default | User | S | N |
|-------------|----------------|-------------|-------------|-------------------|----------------|-------------|----------|----------|
| 502 | Freq Lim | 0 Hz | 300 Hz | 1 Hz | 35 Hz | | ✓ | |
| 503 | Param Lock | 0 | 2 | - | 1 | | | |
| 504 | Start Inhibit | 0 | 1 | - | 1 | | | |
| 505 | Auto Reset | 0 s | 3 s | 0.1 s | 0 s | | | |
| 506 | Display Alarms | 0 | 1 | - | 0 | | | |

Group 01: Actual Values and Status

| Code | Description |
|------|---|
| 101 | Ref Freq Reference frequency. |
| 102 | Last Fault Fault memory. 0 = no fault in memory. Clear the fault memory by pressing the UP/DOWN buttons simultaneously in parameter SET mode. |
| 103 | Version Software version number. |
| 104 | Temp Displays the temperature of the ACS 100 heatsink in degrees centigrade. |

Group 02: Motor Values and Limits

| Code | Description |
|--|--|
| 201 | Nom Volt (U_{nom}) Nominal motor voltage from motor rating plate. Nom Volt sets the maximum output voltage supplied to motor by ACS 100. Nom Freq sets the frequency at which output voltage is equal to the Nom Volt. The ACS 100 cannot supply the motor with a voltage greater than the input voltage. See figure 3. |
| 202 | Nom Freq (f_{nom}) Nominal motor frequency from motor rating plate (field weakening point). See Figure 3. |
| 203 | Nom Curr (I_{nom}) Nominal motor current from the motor rating plate. Note! This parameter is used only when motor thermal protection function is used. Refer to parameter 502 (Freq Lim). See Figure 5. |
| 204 | Nom Speed Nominal motor speed from motor rating plate. |
| 205 | Max Curr Maximum output current the ACS 100 will supply to motor. |
| 206 | Max Freq (f_{max}) Maximum frequency the ACS 100 will supply to motor. |
| 207 | Min Freq (f_{min}) Minimum frequency the ACS 100 will supply to motor. Note! Keep $f_{min} < f_{max}$. |
| <p><i>Figure 1 Usage of f_{min} and f_{max} to limit output frequency.</i></p> | |
| 208 | Dir Lock Direction lock Reverse can be disabled. 1 = FWD / REV 2 = FWD only |
| 209 | Motor Noise Motor noise control. 0 = standard (switching frequency 4 kHz) 1 = low noise (switching frequency 8 kHz) 2 = silent (switching frequency 16 kHz) Note! When the low noise (8 kHz) setting is used, the maximum loadability of the ACS 100 is I_2 at 30 °C ambient temperature or $0.9 * I_2$ at 40 °C. When the silent (16 kHz) setting is used, the maximum loadability is $0.75 * I_2$ at 30 °C ambient temperature. |

Group 03: Drive Control

| Code | Description |
|------|--|
| 301 | <p>Stop Stop mode. 1 = Coast 2 = Ramp See also parameter 307 (DC Inj. Time).</p> |
| 302 | <p>Ramp Ramp shape. 0 = Linear 1 = Fast S curve 2 = Medium S curve 3 = Slow S curve</p> <p><i>Figure 2</i></p> |
| 303 | <p>Acc Acceleration time from zero to maximum frequency ($0 - f_{max}$).</p> |
| 304 | <p>Dec Deceleration time from maximum frequency to zero ($f_{max} - 0$).</p> |
| 305 | <p>U/f Ratio U/f below weakening point. 1 = Linear (curves A and C) 2 = Square (curves B and D) Linear is preferred for constant torque applications and Square for centrifugal pump and fan applications.</p> <p><i>Figure 3</i></p> |
| 306 | <p>IR Comp Amount of IR compensation, i.e. extra voltage applied to motor on frequency range $0 - f_{nom}$. Note! IR compensation should be kept as low as possible.</p> |
| 307 | <p>DC Inj Time DC injection time after modulation has stopped. If stop mode is Coast, ACS 100 uses DC Braking. If stop mode is Ramp, ACS 100 uses DC Hold after ramp.</p> |
| 308 | <p>UC_{max} Overvoltage regulator control. Should be 0, if braking chopper is connected. 0 = No overvoltage control 1 = Overvoltage control enabled</p> |

Group 04: Input/Output

| Code | Description | | | | | | | | | | | | | | | | | | | | | | | | | | | | | | |
|-----------------|---|---|-----------------|----------|--|-----------|-------------|------|-------|--|------|---------|-------------------------------------|------|--|---|--|-----------|----------|--|-----------|-------------|------|------------------|-------------------------------------|------|------------------|-------------------------------------|------|--|---------------------------|
| 401 | AI min Analog input scaling. 0 % equals 0 mA (or 0 V) and 100 % equals 20 mA (or 10 V) at input. | <p><i>Figure 4a</i></p> | | | | | | | | | | | | | | | | | | | | | | | | | | | | | |
| 402 | AI max Analog input scaling. 0 % equals 0 mA (or 0 V) and 100 % equals 20 mA (or 10 V) at input. Note! Keep AI min < AI max | | | | | | | | | | | | | | | | | | | | | | | | | | | | | | |
| 403 | Ref min Reference value for analog input scaling. | <p><i>Figure 4b</i></p> | | | | | | | | | | | | | | | | | | | | | | | | | | | | | |
| 404 | Ref max Reference value for analog input scaling. | | | | | | | | | | | | | | | | | | | | | | | | | | | | | | |
| 405 | DI Config Digital input configuration. 1 = ABB Standard 2 = 3-wire 3 = Alternate Note! After modifications, turn the power off and then on again to validate changes. | <p><i>Table 1 DI configurations.</i></p> <table border="1"> <thead> <tr> <th rowspan="2">ABB Standard</th> <th colspan="2">Function</th> </tr> <tr> <th>activated</th> <th>deactivated</th> </tr> </thead> <tbody> <tr> <td>DI 1</td> <td>start</td> <td>stop</td> </tr> <tr> <td>DI 2</td> <td>reverse</td> <td>forward</td> </tr> <tr> <td>DI 3</td> <td>parameter 406 (Const speed) is f_{ref}</td> <td>analog input is f_{ref}</td> </tr> </tbody> </table> | ABB Standard | Function | | activated | deactivated | DI 1 | start | stop | DI 2 | reverse | forward | DI 3 | parameter 406 (Const speed) is f_{ref} | analog input is f_{ref} | | | | | | | | | | | | | | | |
| ABB Standard | Function | | | | | | | | | | | | | | | | | | | | | | | | | | | | | | |
| | activated | deactivated | | | | | | | | | | | | | | | | | | | | | | | | | | | | | |
| DI 1 | start | stop | | | | | | | | | | | | | | | | | | | | | | | | | | | | | |
| DI 2 | reverse | forward | | | | | | | | | | | | | | | | | | | | | | | | | | | | | |
| DI 3 | parameter 406 (Const speed) is f_{ref} | analog input is f_{ref} | | | | | | | | | | | | | | | | | | | | | | | | | | | | | |
| 406 | Const speed Constant speed. Can be actuated from digital input. See Table 1. | <table border="1"> <thead> <tr> <th colspan="3">3-Wire</th> </tr> <tr> <th colspan="3">Function</th> </tr> </thead> <tbody> <tr> <td>DI 1</td> <td colspan="2">Momentary activation with DI2 activated: start</td> </tr> <tr> <td>DI 2</td> <td colspan="2">Momentary deactivation: stop</td> </tr> <tr> <td>DI 3</td> <td colspan="2">When activated: reverse direction When deactivated: forward direction</td> </tr> </tbody> </table> <table border="1"> <thead> <tr> <th rowspan="2">Alternate</th> <th colspan="2">Function</th> </tr> <tr> <th>activated</th> <th>deactivated</th> </tr> </thead> <tbody> <tr> <td>DI 1</td> <td>start forward</td> <td>stop, if DI2 is also deactivated</td> </tr> <tr> <td>DI 2</td> <td>start reverse</td> <td>stop, if DI1 is also deactivated</td> </tr> <tr> <td>DI 3</td> <td>parameter 406 (Const speed) is f_{ref}</td> <td>analog input is f_{ref}</td> </tr> </tbody> </table> <p>Note! When Alternate is selected, the drive stops, if DI1 and DI2 are activated at the same time.</p> | 3-Wire | | | Function | | | DI 1 | Momentary activation with DI2 activated: start | | DI 2 | Momentary deactivation: stop | | DI 3 | When activated: reverse direction When deactivated: forward direction | | Alternate | Function | | activated | deactivated | DI 1 | start forward | stop, if DI2 is also deactivated | DI 2 | start reverse | stop, if DI1 is also deactivated | DI 3 | parameter 406 (Const speed) is f_{ref} | analog input is f_{ref} |
| 3-Wire | | | | | | | | | | | | | | | | | | | | | | | | | | | | | | | |
| Function | | | | | | | | | | | | | | | | | | | | | | | | | | | | | | | |
| DI 1 | Momentary activation with DI2 activated: start | | | | | | | | | | | | | | | | | | | | | | | | | | | | | | |
| DI 2 | Momentary deactivation: stop | | | | | | | | | | | | | | | | | | | | | | | | | | | | | | |
| DI 3 | When activated: reverse direction When deactivated: forward direction | | | | | | | | | | | | | | | | | | | | | | | | | | | | | | |
| Alternate | Function | | | | | | | | | | | | | | | | | | | | | | | | | | | | | | |
| | activated | deactivated | | | | | | | | | | | | | | | | | | | | | | | | | | | | | |
| DI 1 | start forward | stop, if DI2 is also deactivated | | | | | | | | | | | | | | | | | | | | | | | | | | | | | |
| DI 2 | start reverse | stop, if DI1 is also deactivated | | | | | | | | | | | | | | | | | | | | | | | | | | | | | |
| DI 3 | parameter 406 (Const speed) is f_{ref} | analog input is f_{ref} | | | | | | | | | | | | | | | | | | | | | | | | | | | | | |

Group 05: Supervision

| Code | Description |
|------|---|
| 501 | <p>AI Fault Analog input supervision. 0 = not in use 1 = If analog input is below the level given by parameter 401 (AI min), a fault indication is displayed and the ACS 100 coasts to stop.</p> |
| 502 | <p>Freq Lim (f_{lim}) Frequency limit for thermal protection. Together with parameter 203 (Nom Curr) determines the continuous safe operation area for the motor. 0 Hz = Thermal protection disabled.</p> <p><i>Figure 5</i></p> |
| 503 | <p>Param Lock Parameter lock. 0 = START/STOP and REVERSE buttons and parameter modification disabled. Parameter value viewing is allowed. 1 = Not locked. 2 = Modified values not stored in permanent memory.</p> |
| 504 | <p>Start Inhibit Start inhibit control. Start inhibit provides that a pending start command is ignored when:</p> <ul style="list-style-type: none"> • fault is reset, or • mode change from local to remote takes place. <p>0 = Off Start inhibit control disabled. Drive will start after fault is reset or mode is changed while there is a pending start command. 1 = On Start inhibit control is enabled. Drive will not start after fault is reset or mode is changed. In order to start the drive again, give start command anew.</p> |
| 505 | <p>Auto Reset The automatic reset system can be used for resetting undervoltage faults automatically. Auto reset sets the number of allowed auto resets (5) within a certain time (30 s). 0 s = Disable</p> <p>If a value greater than 0 s is selected, the undervoltage fault is reset automatically after the delay set by this parameter. If 0 s is selected, the fault is not reset automatically.</p> <p>x = Automatic reset</p> <p><i>Figure 6 Operation of automatic reset function. The number of trials is constant 5 and the trial time is constant 30 s. By moment 'Now' three faults has occurred making the next fault fourth, the system is reset automatically because the number of trials is less than 5.</i></p> |

| | |
|-----|--|
| 506 | Display Alarms Controls the visibility of some of the alarms, see "Diagnostics" on page 31. 0 = No Some of the alarms are suppressed. 1 = Yes All of the alarms are enabled. |
|-----|--|

Diagnostics

General

This chapter describes the various diagnostic displays of the control panel and lists the most common causes for the particular display. If the fault cannot be resolved by the given instructions, contact your local ABB Authorized Service Representative.

Caution! Do not attempt any measurement, parts replacement or other service procedures not described in this manual. Such actions will void warranty, endanger correct operation, and increase downtime and expense.

Alarm and Fault displays

The seven-segment display unit of control panel indicates alarms and faults using codes "ALxx" or "FLxx", where xx is the corresponding alarm or fault code.

Alarms 1-6 arise from button operation. The green LED blinks for AL10-16, meaning that the ACS 100 cannot fully follow the control commands. The faults are indicated by the red LED.

The alarm and fault messages disappear by pressing MENU, ENTER or the arrow buttons of the control panel. The message will reappear after a few seconds if the keypad is not touched and the alarm or fault is still active.

Last fault code is stored into parameter 102. This fault memory can be cleared from the control panel by pressing the UP and DOWN buttons simultaneously in parameter set mode.

Fault Resetting

Faults that are indicated by a red blinking LED are reset by turning the power off for a while. Other faults (indicated by red static LED) can be reset either from the control panel, by digital input or serial communication, or switching the supply voltage off for a while. When the fault has been removed, the motor can be started.

The ACS 100 can be configured to automatically reset certain faults. Refer to parameter 505 AUTO RESET.

Warning! If an external source for start command is selected and is still active, the ACS 100 may start immediately after fault reset.

Warning! All electrical installation and maintenance work described in this chapter should only be undertaken by a qualified electrician. The Safety Instructions on the first pages of this manual must be followed.

Table 2 Alarms

| Code | Description |
|-------------|---|
| CF 0 - CF 9 | Position of configuration switch S1. Certain parameters can be modified only when S1 = 0. |
| AL 1 | Parameter upload/download failed. |
| AL 2 | Operation not allowed while start is active. |
| AL 3 | Operation not allowed in remote or local control. |
| AL 4 | REVERSE button disabled. Parameter 208 (Dir Lock) is active. |
| AL 5 | Panel START button disabled. DI configuration is 3-wire and DI2 is open. |
| AL 6 | Operation not allowed. Parameter 503 (Param Lock) is active. |
| AL10* | Overcurrent controller active. |
| AL11* | Overvoltage controller active. |
| AL12* | Undervoltage controller active. |
| AL13 | Reserved. Contact the factory. |
| AL14 | Reverse command attempted in remote control (REM), while parameter 208 (Dir Lock) is active. |
| AL15 - AL16 | Reserved. Contact the factory. |

Note! Alarms (*) will be shown only if parameter 506 is set to 1 (Yes).

Table 3 Faults

| Code | Description |
|-----------------------|---|
| FL 1 | Overcurrent: <ul style="list-style-type: none"> • Possible mechanical problem. • Acc and/or Dec times may be too small. |
| FL 2 | DC overvoltage: <ul style="list-style-type: none"> • Input voltage too high. • Dec time may be too small. |
| FL 3 | ACS 100 overtemperature: <ul style="list-style-type: none"> • Ambient temperature too high. • Severe overload. |
| FL 4 * | Fault current: output ground fault or short circuit. |
| FL 5 | Output overload. |
| FL 6 | DC undervoltage. |
| FL 7 | Analog input fault. (See parameter 501.) |
| FL 8 | Motor overtemperature. (See parameter 502.) |
| FL 9 | Panel disconnected from drive in local control. Note! If FL 9 is active when the power is turned off, the ACS 100 will start in remote control (REM) when the power is turned back on. |
| FL10 | Parameters inconsistent. Check that AI min (f_{min}) is not greater than AI max (f_{max}). |
| FL11 * | DC bus ripple too large. Check supply. |
| FL12 | Reserved. Contact the factory. |
| FL13 - FL14* | Hardware error. Contact the factory. |
| FL15* | Analog input out of range. Check AI level. |
| FL16-FL19* | Hardware error. Contact the factory. |
| Full display blinking | Serial link failure. Bad connection between the control panel and the ACS 100. |

Note! Faults (*) with red blinking LED are reset by turning the power off and on. Other faults are reset by pressing the START/STOP button.

ACS 100 EMC Instructions

Mandatory Installation Instruction According to the EMC Directive for type ACS 100 frequency converters

Follow the instructions given in the ACS 100 User's Manual and the instructions delivered with different accessories.

CE Marking

A CE mark is attached to ACS 100 frequency converters to verify that the unit follows the provisions of the European Low Voltage and EMC Directives (Directive 73/23/EEC, as amended by 93/68/EEC and Directive 89/336/EEC, as amended by 93/68/EEC).

The EMC Directive defines the requirements for immunity and emissions of electrical equipment used in European Economic Area. The EMC product standard EN 61800-3 covers the requirements stated for frequency converters. ACS 100 frequency converters comply with the requirements stated in EN 61800-3 for Second Environment and First Environment.

Product standard EN 61800-3 (Adjustable speed electrical power drive systems - Part 3: EMC product standard including specific test methods) defines **First Environment** as an environment that includes domestic premises. It also includes establishments directly connected without intermediate transformers to a low voltage power supply network which supplies buildings used for domestic purposes. **Second Environment** includes establishments other than those directly connected to a low voltage power supply network which supplies buildings used for domestic purposes. With the ACS 100 in the Second Environment, no RFI filter is needed.

C-Tick Marking (pending)

A C-tick mark is attached to 1-phase ACS 100 frequency converters to verify that the unit follows the provisions of the Australian Statutory Rules No 294, 1996, Radiocommunication (Compliance Labelling - Incidental Emissions) Notice and the Radiocommunication Act, 1989, and the Radiocommunication Regulations, 1993, of New Zealand.

The statutory rules defines the essential requirements for emissions of electrical equipment used in Australia and New Zealand. The standard AS/NZS 2064, 1997, Limits and methods of measurement of electronic disturbance characteristics of industrial, scientific and medical (ISM) radiofrequency equipment, covers the detailed requirements for a frequency converters.

The frequency converter ACS 100 complies with the AS/NZS 2064, 1997, limits for class A equipment. Class A equipment is suitable for use in all establishments other than domestic and those directly connected to a low voltage network which supplies buildings used for domestic purposes. The compliance is valid with the following provisions:

- The frequency converter is equipped with RFI-filter.
- The motor and control cables are chosen as specified in this manual for use in public low-voltage network.
- The installation rules of this manual are followed.

Cabling Instructions

Keep individual unscreened wires between the cable clamps and the screw terminals as short as possible. Route control cables away from power cables.

Input Power

A three conductor cable (single phase and neutral with protective ground) or four conductor cable (three phase with protective ground) are recommended for the input cabling. Shielding is not necessary. Dimension the cables and fuses in accordance with the input current. Always pay attention to local codes when sizing the cables and fuses.

The input power connectors are at the top of the converter unit. Input cable routing must be done so that the distance from the sides of the converter is at least $13/16''$ (20 cm) to avoid excessive radiation to the input cable. In the case of screened cable, twist the cable screen wires together into a bundle not longer than five times its width and connect to the PE terminal of the converter. (Or PE terminal of the input filter, if present.)

Motor Cable

The motor cable must be a symmetrical three conductor cable with a concentric PE conductor or a four conductor cable with a concentric shield. The minimum requirement for the motor cable screen is presented in Figure 7.

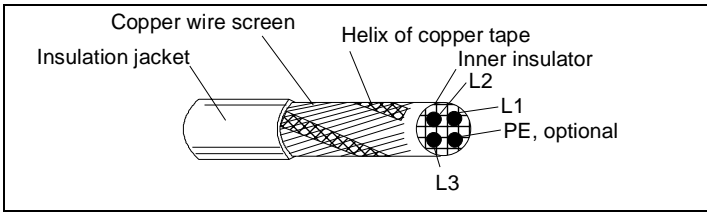

Figure 7 Minimum requirement for motor cable screen (e.g. MCMK, NK Cables).

The general rule for cable screen effectiveness is: the better and tighter the screen of the cable, the lower the radiated emission level. Example of an effective construction is presented in Figure 8.

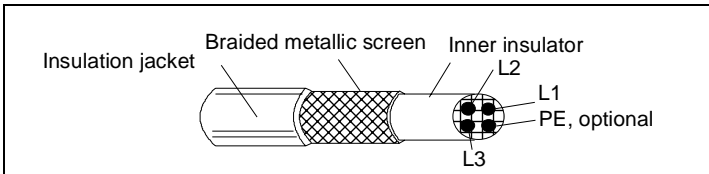

Figure 8 Effective motor cable screen (e.g. Ölflex-Servo-FD 780 CP, Lappkabel or MCMK, NK Cables).

Twist the cable screen wires together into a bundle not longer than five times its width and connect to the terminal located on the bottom left-hand corner of the drive heatsink (terminal marked \perp).

At the motor end, the motor cable screen must be grounded 360 degrees with an EMC cable gland (e.g. ZEMREX SCG Screened cable glands) or the screen wires must be twisted together into a bundle not longer than five times its width and connected to the PE terminal of the motor.

Control Cables

Control cables must be multi-core cables with a braided copper wire screen.

The screen must be twisted together into a bundle not longer than five times its width and connected to terminal X1:1.

Route the control cables as far away as possible from the input and motor cables (at least 13/16" (20 cm)). Where control cables must cross power cables make sure they are at an angle as near 90 degrees as possible. Also the cable routing must be done so that the distance from the sides of the converter is at least 20 cm to avoid excessive radiation to the cable.

A double shielded twisted pair cable is recommended for the analog signals. Employ one individually shielded pair for each signal. Do not use common return for different analog signals.

A double shielded cable is the best alternative for low voltage digital signals but single shielded twisted multipair cable is also usable (see Figure 9).



Figure 9 A double shielded twisted pair cable on the left and a single shielded twisted multipair cable on the right.

The analog and digital input signals should be run in separate, screened cables.

Relay-controlled signals, providing their voltage does not exceed 48 V, can be run in the same cables as digital input signals. It is recommended that the relay-controlled signals be run as twisted pairs.

Never mix 24 VDC and 115/230 VAC signals in the same cable.

Control Panel Cable

If the control panel is connected to the converter with a cable, use only the cable provided with the option package ACS100-EXT. Follow the instructions delivered with the option package.

Route the control panel cable as far away as possible from the mains and motor cables (at least 13/16" (20 cm)). Also the cable routing must be done so that the distance from the sides of the converter is at least 13/16" (20 cm) to avoid excessive radiation to the cable.

Additional Instructions to Comply with EN61800-3, First Environment, Restricted Distribution, and AS/NZS 2064, 1997, Class A

Always use an optional RFI filter as specified in Tables 4 and 5 and follow the instructions in the filter package for all cable screen connections.

The filters with regular cable lengths are shown in Table 4 and the filters with extra long cable lengths in Table 5.

The motor cable lengths have to be limited as specified in Tables 4 and 5. At the motor end, the cable screen must be grounded 360 degrees with an EMC cable gland (e.g. Zemrex SCG screened cable glands).

Table 4 Maximum motor cable lengths with input filter ACS100/140-IFAB-1 or -IFCD-1 and switching frequency 4 kHz, 8 kHz or 16 kHz.

| Converter type | ACS100/140-IFAB-1 | | |
|--------------------------------|-------------------|-------|--------|
| | 4 kHz | 8 kHz | 16 kHz |
| ACS 101-K18-1 ACS 101-H18-1 | 30 m | 20 m | 10 m |
| ACS 101-K25-1 ACS 101-H25-1 | 30 m | 20 m | 10 m |
| ACS 101-K37-1 ACS 101-H37-1 | 30 m | 20 m | 10 m |
| ACS 101-K75-1 ACS 101-H75-1 | 30 m | 20 m | 10 m |
| ACS 101-1K1-1 ACS 101-1H1-1 | 30 m | 20 m | 10 m |
| ACS 101-1K6-1 ACS 101-1H6-1 | 30 m | 20 m | 10 m |
| Converter type | ACS100/140-IFCD-1 | | |
| ACS 101-2K1-1 | 30 m | 20 m | 10 m |
| ACS 101-2K7-1 | 30 m | 20 m | 10 m |
| ACS 101-4K1-1 | 30 m | 20 m | 10 m |

Table 5 Maximum motor cable lengths with input filter ACS100-FLT-C or ACS 140- FLT-C and switching frequency 4 kHz or 8 kHz.

| Converter Type | ACS100-FLT-C | |
|-----------------|--------------|--------|
| | 4 kHz | 8 kHz* |
| ACS 101-K75-1 | 100 m | 100 m |
| ACS 101-1K1-1 | 100 m | 100 m |
| ACS 101-1K6-1 | 100 m | 100 m |
| ACS 101-2K-1 | 100 m | 100 m |
| ACS 101-2K7-1 | 100 m | 100 m |
| ACS 101-4K1-1 | 100 m | 100 m |
| Converter Type | ACS140-FLT-C | |
| ACS 103-xKx-1** | 100 m | 100 m |

* Effective motor cable screen is required, according to Figure 8.

**ACS 103-4K1-1: maximum continuous load 70 % of nominal.

For ACS 101-4K1-1 and ACS 103-4K1-1, a cable shown in Figure 8 is required.

Always use output choke ACS-CHK-B, if motor cable length exceeds 50 m.

With input filter ACS100-FLT-C always use output choke ACS-CHK-A.

Chokes ACS-CHK-A and ACS-CHK-B are supplied in the same package with input filters ACS100-FLT-C.

With input filters ACS100-FLT-C or ACS140-FLT-C conducted emission complies with the limits for unrestricted distribution class in First Environment as specified in EN 61800-3 (EN 50081-1) provided that the motor cable has effective screen (see Figure 8) and maximum length is 30 m.

Additional Instructions to Comply with EN61800-3, First Environment, Unrestricted Distribution

Always use optional RFI filter ACS100-FLT-D or ACS100-FLT-E and follow the instructions in the filter package for all cable screen connections.

The motor cable lengths have to be limited as specified in Table 6 and the cable must have effective screen according to Figure 8. At the motor end, the cable screen must be grounded 360 degrees with an EMC cable gland (e.g. Zemrex SCG screened cable glands).

Table 6 Maximum motor cable lengths with input filter ACS100-FLT-D, -E or ACS140-FLT-D and switching frequency 4 kHz.

| Converter type | ACS100-FLT-D | ACS100-FLT-E |
|----------------|--------------|--------------|
| | 4 kHz | 4 kHz |
| ACS 101-K75-1 | 5 m | - |
| ACS 101-1K1-1 | 5 m | - |
| ACS 101-1K6-1 | 5 m | - |
| ACS 101-2K1-1 | - | 5 m |
| ACS 101-2K7-1 | - | 5 m |
| ACS 101-4K1-1 | - | 5 m |

Two chokes ACS-CHK-A or ACS-CHK-C are supplied in the filter package. The motor cable including the shield must be fed through the hole in the choke. Also all control cables and the control panel cable, if present, must be fed through another choke. The cable lengths between the converter and the chokes must be at maximum 50 cm.

For types ACS 101-2K1-1, ACS 101-2K7-1 and ACS 101-4K1-1 the control panel, if present, must be mounted on the converter front cover.

Line Current Harmonics

The product standard EN 61800-3 refers to IEC 61000-3-2 which specifies limits for harmonic current emissions for equipment connected to low voltage public supply network.

The ACS 100 is a professional equipment to be used in trades, professions, or industries and is not intended for sale to the general public. The supply authorities shall be notified as authorization may be required before connection.

The current harmonic levels under rated load conditions are available on request.

Distribution Networks Isolated from Ground

Input filters cannot be used in floating supply networks, or high impedance grounded industrial distribution networks.

Make sure that no excessive emission is propagated to neighboring low voltage networks. In some cases, the natural suppression in transformers and cables is sufficient. If in doubt, a supply transformer with static screening between the primary and secondary windings can be used.



ABB Automation Inc.
Drives & Power Products Group
16250 W. Glendale Drive
New Berlin, WI 53151
Telephone (262) 785-8378
(800) 243-4384
Fax (262) 780-5135

ACS100U-US-04
3AJA489002B3919 R0101 Rev. B
Effective: 8/1/00
Supersedes: 9/1/97
© 2000 ABB Automation Inc.
Subject to change without prior notice.