

# Hydronic System Types

# HYDRONIC SYSTEM CLASSIFICATIONS

Hydronic heating and cooling systems are classified as being either "open" or "closed", and sub-classified as to the return piping arrangement; direct, reverse, or a combination of the two methods.

Additionally, distribution piping systems may be one-pipe, two-pipe or four-pipe.

The engineer, designer and contractor should become totally familiar with the advantages, disadvantages, peculiarities, and limitations of these various systems in order that intelligent, compatible and economic applications can be made .

## OPEN PIPING SYSTEMS

An open piping system is one in which a part of the piping circuitry contains a reservoir that is open to the atmosphere, such as a cooling tower or pond, air washer, open storage tank, or a similar device . A system with an open-type expansion tank, is considered an open system.

A typical open system is illustrated in Figure 1.

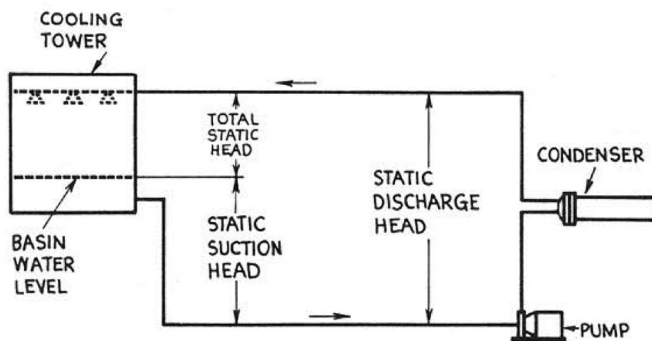

**Figure 1**  
**Typical Open Piping System**

In any open system the static suction head (or lift) and the static discharge head (negative or positive), as well as the friction loss of the pipe, fittings, valves and other equipment in the circuit, must be evaluated when calculating the total pumping head requirement.

## CLOSED PIPING SYSTEMS

A closed piping system, as the name implies, is one that is completely sealed, and hence not affected by atmospheric pressure as is an open system.

Only the friction loss of the pipe, fittings and other system components need be considered when calculating system pressure drops. Static heights do not affect pressure drops in closed systems.

## DIRECT-RETURN PIPING SYSTEMS

A direct return piping system returns the liquid directly (See Figure 2) and consequently, all circuits are usually of unequal length and inherently unbalanced.

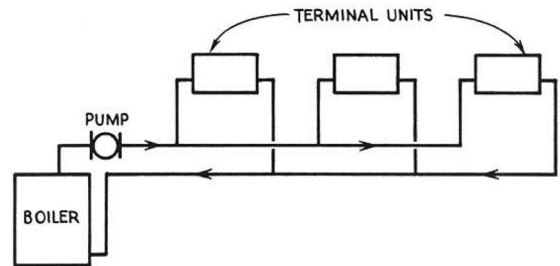
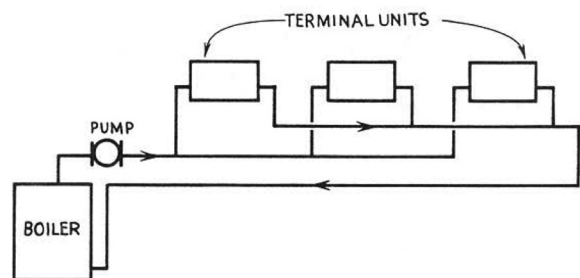

**Figure 2**  
**Typical Direct-Return Piping System**

If terminal units have widely varying pressure drops or if throttling-type valves are used to control flow rates, it is generally advisable to use a direct return piping arrangement.

## REVERSE - RETURN PIPING SYSTEMS

Reverse-return piping arrangements are preferred for most larger Hydronic Systems, particularly radiant panels, because their equal-length circuits require a minimum of balancing. (See Figure 3).



**Figure 3**  
**Typical Reverse - Return Piping Systems**

The designer should attempt to select all terminal units with nearly-equal pressure drops if a reverse-return arrangement is to be used.

If the above considerations cannot be met, the primary advantage of a reverse-return piping arrangement will be lost, and the use of a lower-cost direct-return system would be more practical.

**DIRECT-REVERSE COMBINATION RETURN SYSTEMS**

A reverse return header with direct return risers (See Figure 4) is a compromise between a direct and a reverse-return system.

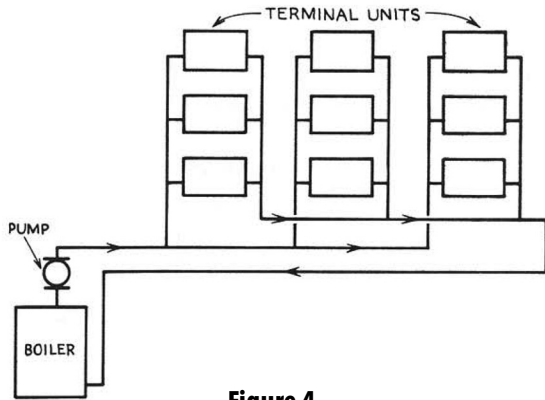
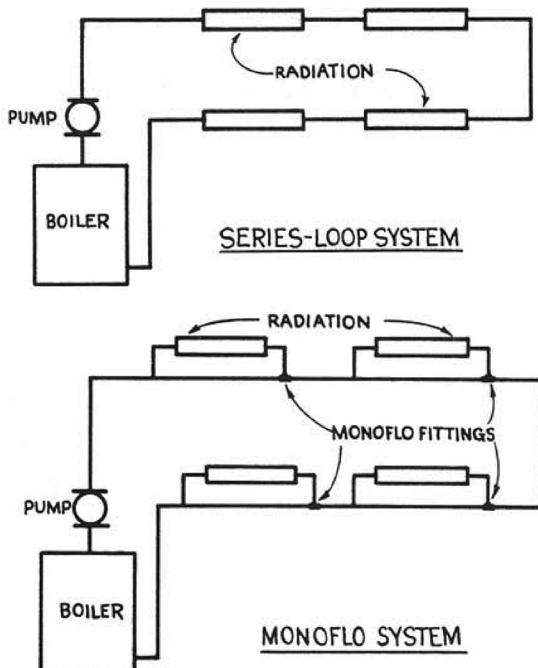

**Figure 4**  
**Reverse - Return Header with Direct - Return Riser Systems**

Required terminal unit flow rates will be maintained to plus or minus 10% of design if the riser pressure drop (combined supply and return) does not exceed 50% of the terminal unit pressure drop.

**ONE-PIPE SYSTEMS**

One-pipe arrangements utilize a continuous single piping loop that serves as both a supply and a return line (See Figure 5).



**Figure 5**  
**Typical One-Pipe Systems**

One -pipe systems are generally used in small buildings or as sub-circuits in larger systems.

A series loop system consists of a series of heat emission units connected together by a single pipe main. The heat emission units are part of the piping circuit . There are no diversion tees needed. The size of the pipe main remains the same. Therefore, the length of the circuit is very important because of pressure drop and temperature drop.

While the series loop system has the lowest possible first cost, its primary draw- back is that neither temperature nor flow rate to any heating element can be regulated without affecting all other elements in the circuit. Additionally, the maximum circuit capacity is limited by the size of the element tube.

In the single main (one-pipe) Monoflo System, water is diverted from the main into the heat emission unit by a diverter tee, and returned into the same main. The diverter tees are designed and sized to cause a flow in the branch circuits dependent on the requirement of the heat emission unit. Because of the one-pipe circuit, there is no possibility of short circuiting.

The Monoflo System has an advantage over the Series Loop System because flow rates to each heating element can be controlled by means of valves, or cocks, located in the risers or runouts.

**TWO-PIPE SYSTEMS**

Two-pipe distribution systems have separate supply and return mains and are widely-used for all sizes of systems. Typical two-pipe systems are illustrated in Figures 1, 2, 3, and 4.

### THREE- PIPE SYSTEMS

Three-pipe systems are no longer allowed by the ASHRAE energy standard 90.1. However, you may encounter some that were installed many years ago.

In a three-pipe system, separate mains are used to supply hot and chilled water to the terminal units, making heating and cooling available year-around. The return runouts are connected to a common return main. Either separate hot and chilled water supply pumps, or a single pump, located in the common return may be employed. A typical three-pipe system is shown in Figure 6.

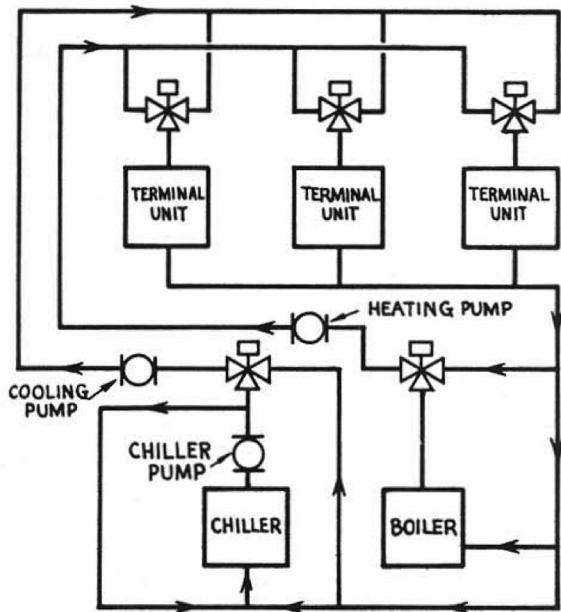

**Figure 6**  
**Typical Three-Pipe System**

### FOUR-PIPE SYSTEMS

A four-pipe arrangement is simply a two-pipe heating and a two-pipe cooling system connecting with one or more terminal units. The heat transfer element may be a single coil through which either hot or chilled water may be circulated, or it may be two separate coils within the same terminal unit, one used for heating and the other for cooling, and dehumidifying. The latter method provides complete hydraulic isolation between the two systems. Figure 7 illustrates a typical four-pipe system utilizing single-coil terminal units.

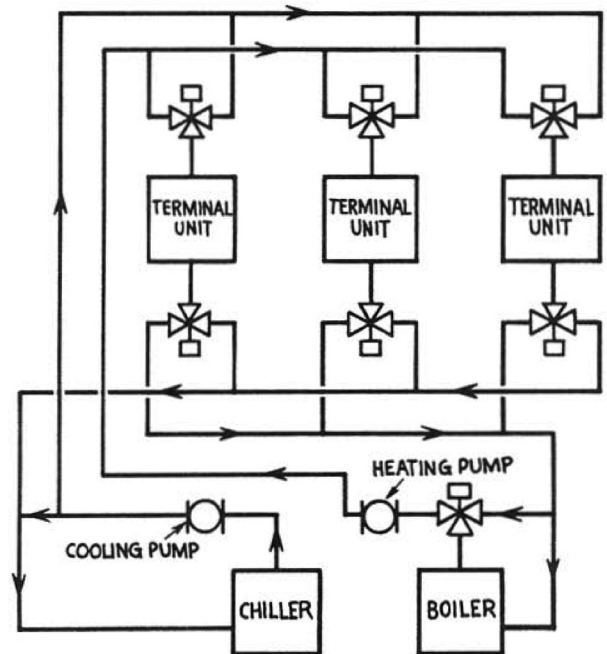

**Figure 7**  
**Typical Four- Pipe System**

## PRIMARY- SECONDARY SYSTEMS

Secondary pumping systems are used in larger commercial, residential, and industrial buildings where zoning and/or varying secondary liquid temperatures are required. Because system pumping is divided into two or more circuits, maximum individual pump horse powers are lower than for centralized pumping systems. A typical primary- secondary arrangement utilizing a two-pipe direct-return primary system is illustrated in Figure 8.

The primary circuit may be either one-pipe, two-pipe, direct-return or two-pipe reverse-return. In normal practice, the primary pump continuously circulates water through the primary circuit.

The piping used in the secondary zones may be any of the presently accepted methods - Monoflo, two-pipe, direct or reverse return, panel, series loop or to serve heat exchangers for domestic hot water and snow melting systems.

The secondary circuits can be controlled by single pump operation, injection pumps, three-way valves and two-way valves.

Heating and cooling combination systems can be designed to use the primary as the same distribution main and the secondary as combination heating and cooling circuits.

Secondary systems may be adapted to either new or existing conventional one-pipe or two-pipe distribution mains.

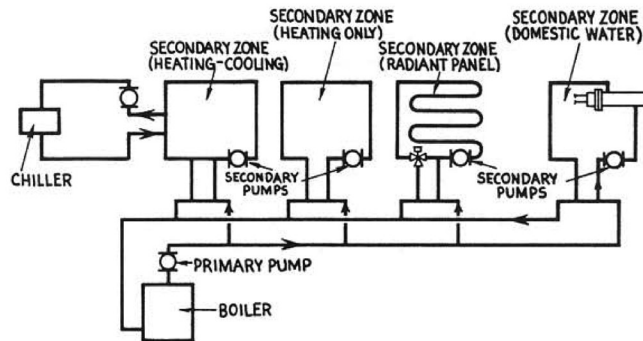

**Figure 8**  
**Typical Primary-Secondary System**

## RADIANT PANEL SYSTEMS

Panel comfort heating is accomplished by means of pipe coils embedded in floors, walls or ceilings, through which hot water is circulated. Some of the various piping configurations in common use are illustrated in Figure 9.

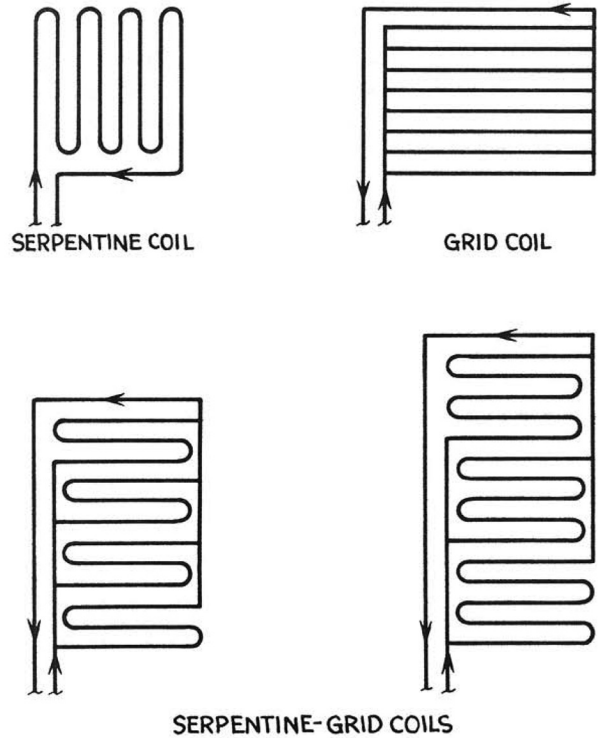

**Figure 9**  
**Typical Radiant Panel Configurations**

Serpentine coils are easier to design and install where irregular patterns are involved, but they have high pressure drops and should be limited to relatively small areas.

Grid coil panels have lower pressure drops and consequently are suitable where larger panels are required. In designing grid coils the ratio of lateral length to header length should be no less than 2 to 1 or severe balance problems may result.

Combination grid-serpentine coils combine the virtues of the grid and the serpentine coils; they can be used for large panels, pressure drops are relatively low, and fabrication costs are less than for grid coil systems.

# Xylem |'zīləm|

- 1) The tissue in plants that brings water upward from the roots;
- 2) a leading global water technology company.

We're 12,500 people unified in a common purpose: creating innovative solutions to meet our world's water needs. Developing new technologies that will improve the way water is used, conserved, and re-used in the future is central to our work. We move, treat, analyze, and return water to the environment, and we help people use water efficiently, in their homes, buildings, factories and farms. In more than 150 countries, we have strong, long-standing relationships with customers who know us for our powerful combination of leading product brands and applications expertise, backed by a legacy of innovation.

**For more information on how Xylem can help you, go to [www.xyleminc.com](http://www.xyleminc.com)**



Xylem Inc.  
8200 N. Austin Avenue  
Morton Grove, Illinois 60053  
Phone: (847) 966-3700  
Fax: (847) 965-8379  
[www.bellgossett.com](http://www.bellgossett.com)

Bell & Gossett is a trademark of Xylem Inc. or one of its subsidiaries.  
© 2013 Xylem Inc. TEH-471A January 2013