



TECHNICAL MANUAL
TEH-1275A

Equipment Room Piping Practice

EQUIPMENT (BOILER) ROOM PIPING PRACTICE

I. GENERAL DESIGN AND APPLICATION RULES

The following design and application rules apply to all equipment rooms whether intended for heating only, dual chilled and hot water, instantaneous chilled and hot (3 or 4 pipe) or zoned chilled and hot.

1. Distribution pumps must discharge into the piping system with the compression tank connection located at the pump suction.

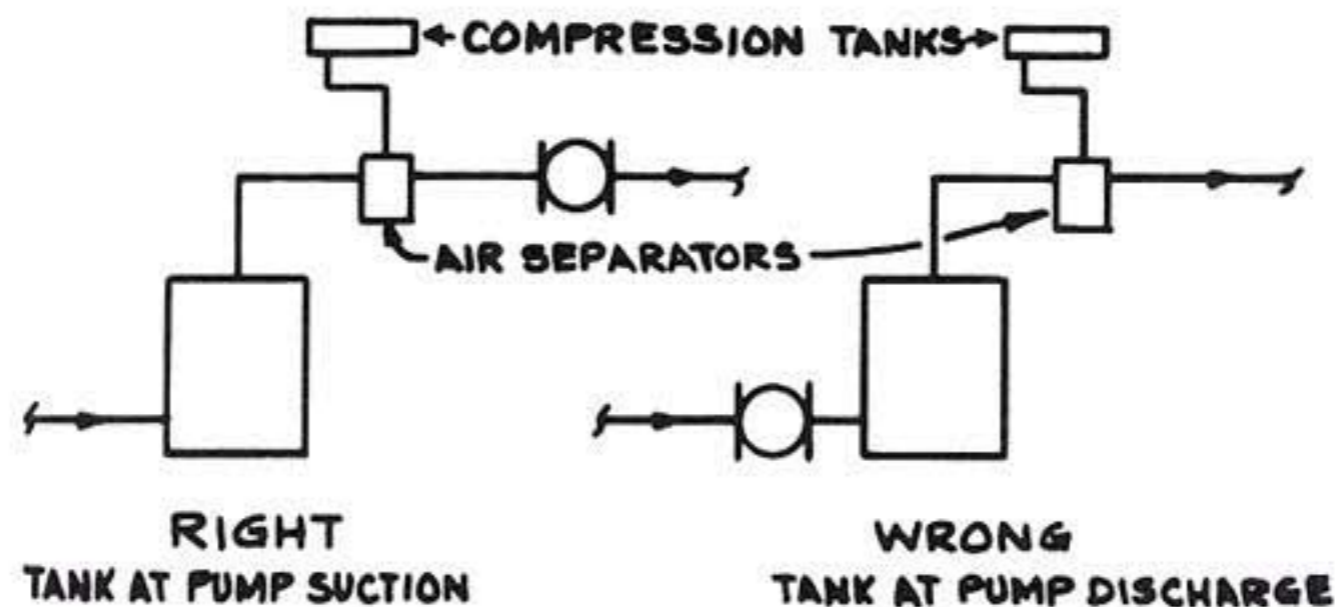

Figure 1 - RIGHT AND WRONG PUMP LOCATION

The wrong pump location will decrease system static pressure by an amount equal to the operating pump head. System circulation and mechanical pump troubles will occur.

The properly located pump increases system static pressure during operation and eliminates trouble potential.

2. PUMP SELECTION

Distribution pumps should be selected to approximate curve midpoint, using flat curved pumps.

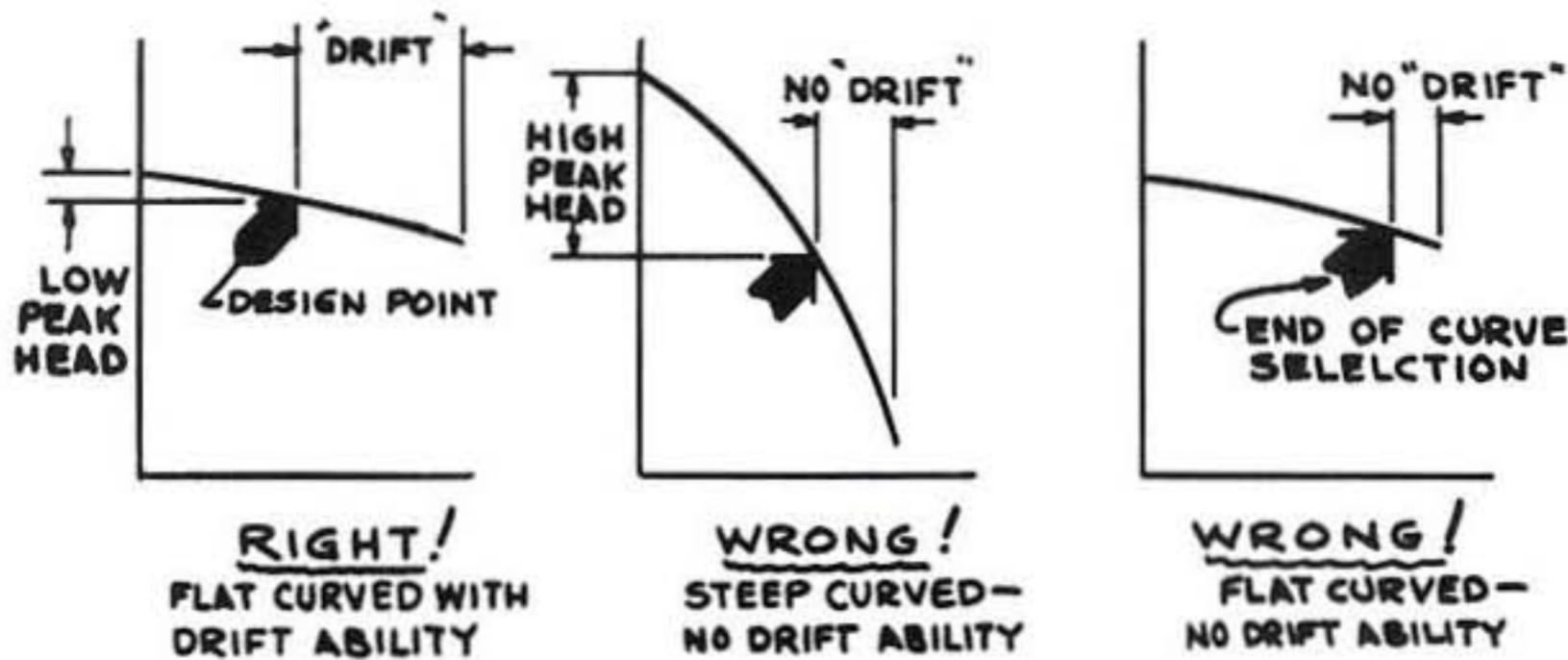

Figure 2 - RIGHT AND WRONG PUMP SELECTIONS

System distribution pumps should be selected for system needs. The large multi-circuited hydronic system needs a pump selection that will help overcome circuit distribution problems.

3. PIPING SIZE AT PUMP SUCTION AND DISCHARGE

Pipe size at the pump suction and discharge should conform to distribution main size; not to suction and discharge pump opening size.

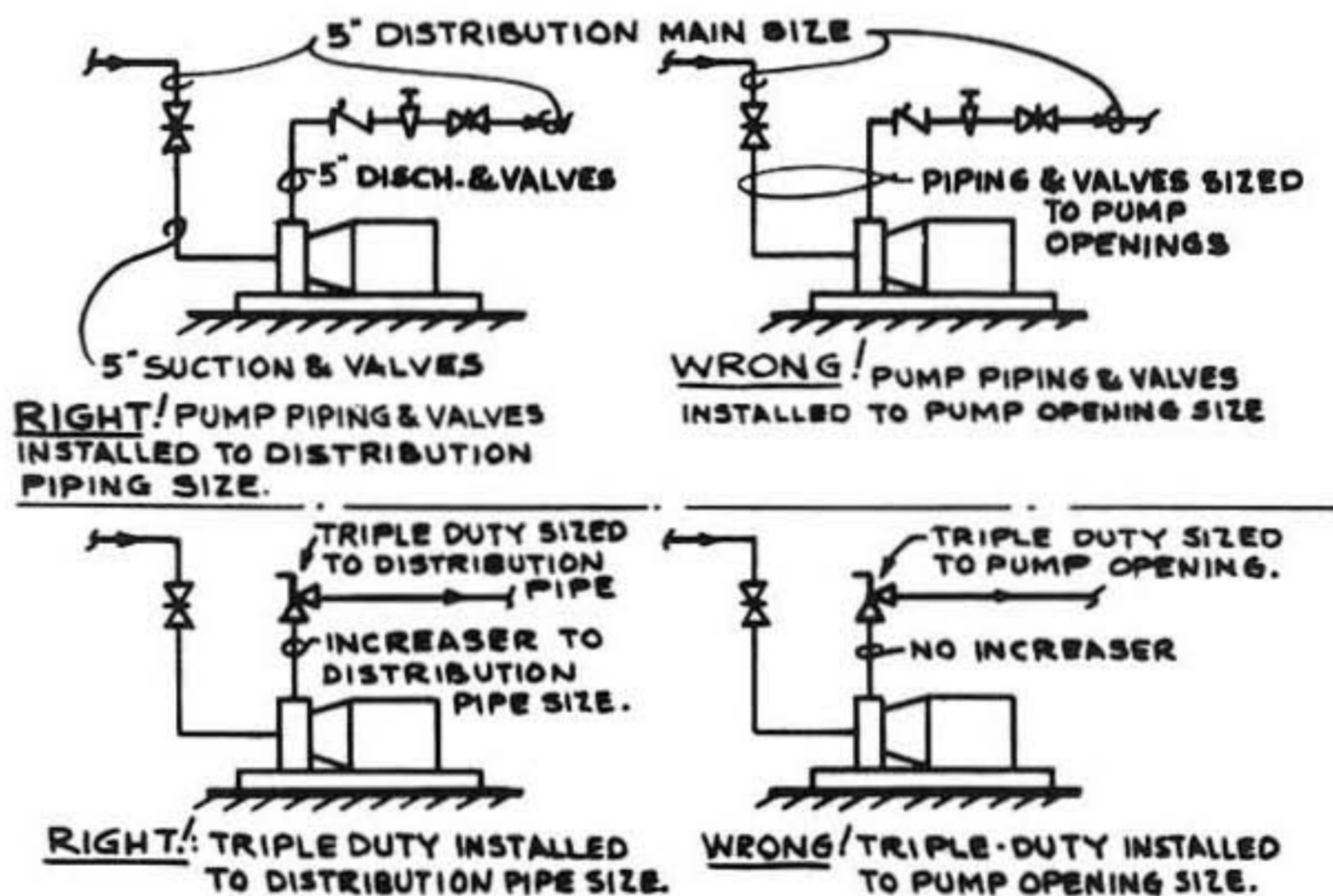

FIGURE 3 - RIGHT AND WRONG PUMP PIPE AND VALVE SIZING

Suction and discharge piping (and valves) sized to the pump opening works against system flow distribution needs because of unwarranted increases in equipment room pressure drop.

4. PUMP SUCTION PIPE LENGTH

The pump suction "straight" run pipe length should be at least 5 DIA. of suction pipe size to insure good pump entry conditions.

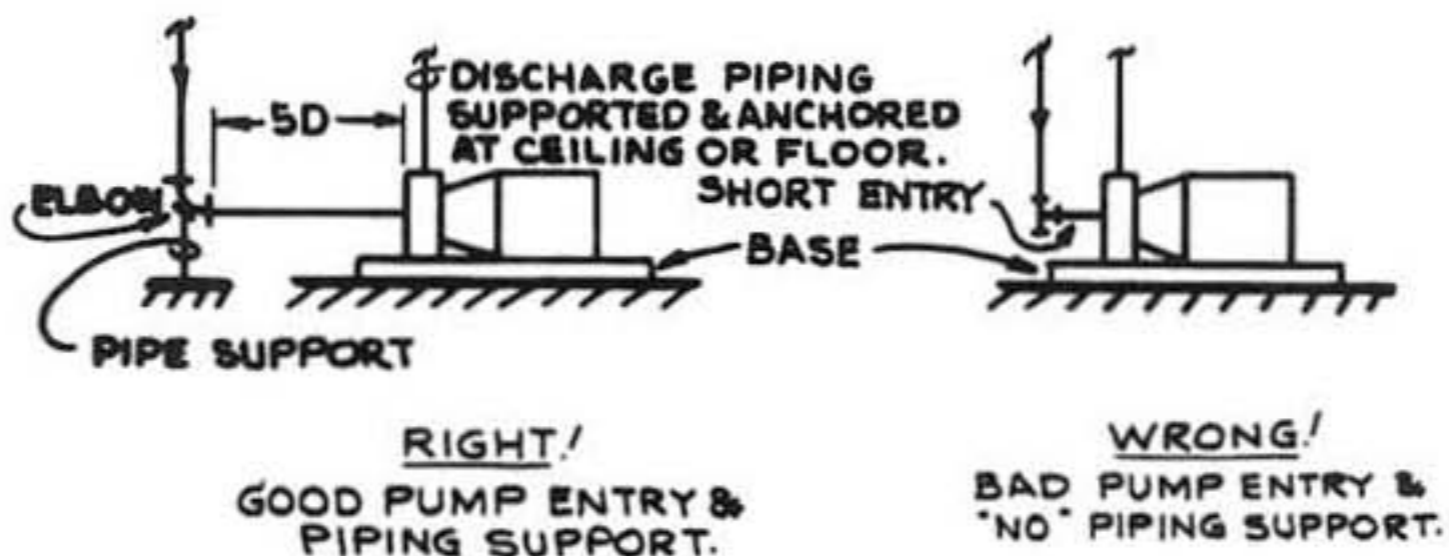

FIGURE 4 - RIGHT AND WRONG PUMP ENTRY CONDITIONS

5. PUMP PIPING SUPPORT

Pump piping support should be provided as shown in Figure 4. The pump should not serve as a piping anchor.

6. MULTIPLE PUMP CHECK VALVES

Check valves (conventional, Triple Duty or Flo Control) should be installed at each pump discharge when more than one pump is used in the equipment room. This applies whether the additional pumps are for standby, parallel operation or zone pumping.

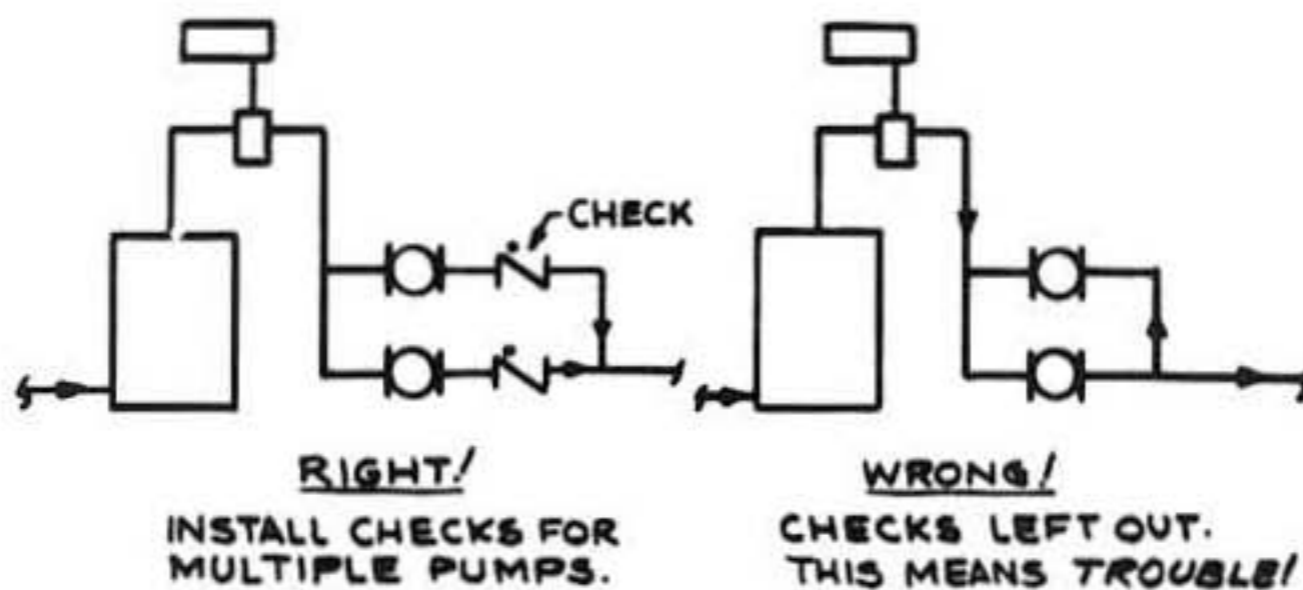

FIGURE 5 - MULTIPLE PUMP CHECK VALVES

Trouble will develop when check valves are not installed because of reversed flow through non-operating pumps. When these pumps are started, they must overcome a heavy flow inertia load and will overload.

7. ZONE PUMP STRAINERS

Zone pumps should not use a single fine mesh strainer in the header piping. Clogging of this single strainer can lead to non-operation and freeze up in low pump head zones.

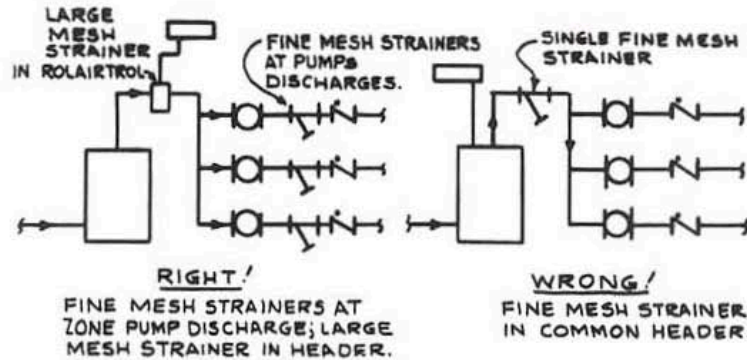

FIGURE 6 - STRAINER APPLICATION

Fine mesh strainers are often used to protect control valves, etc. They are not needed for pump protection. When fine mesh steam type strainers are used, their best application point is either at the pump discharge or out in the system.

It is considered good practice to remove strainers from the water system after 2 to 3 months operation. While in use, the strainers should be watched continually for clogging.

8. AIR SEPARATOR LOCATION

The air separator should be located so that full system flow passes through it.

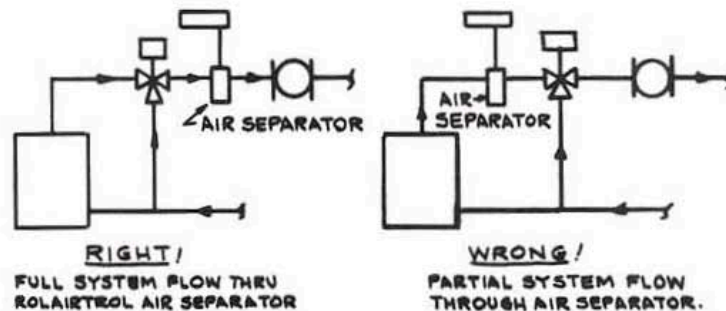

FIGURE 7* - FULL SYSTEM FLOW THROUGH SEPARATOR

* Piping arrangements with 3-Way control valves shown within this technical manual are provided by Bell & Gossett as reference information of existing systems only. As an active participating member of ASHRAE, it is Bell & Gossett's recommendation that engineers and system designers consult with the most current ASHRAE Standards for design guidance on Variable Flow Systems or Constant Flow Systems as indicated in ASHRAE Standard 90.1 Section 6.5.4.

II. EQUIPMENT OR BOILER ROOM PIPING PRACTICE; HEATING AND/OR COOLING AIR SEPARATION

The following illustrates a series of specific application solutions for various Equipment Room problems:

1. FLOOR MOUNTED COMPRESSION TANK

Floor mounted compression tanks are used because of limited ceiling height above boilers or air separators and to eliminate special ceiling structure design necessary for large ceiling hung tanks.

The basic problem concerning the floor mounted tank is introduction of separated air from an overhead point into the tank. This problem is solved by the arrangement shown in Figure II-1.

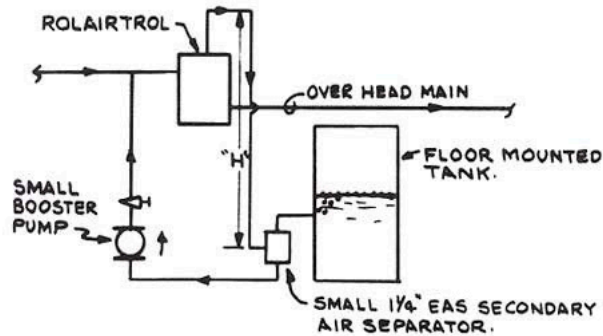

FIGURE II-1 - FLOOR MOUNTED COMPRESSION TANK

In Figure II-1, main system air is liberated in the overhead main air separating Rolairtrol. This air is then pumped down into the small EAS type separator from which it is delivered into the bottom of the floor mounted tank.

The small booster pump provides the driving energy head for delivery of overhead air to the tank. This pump must be selected so that its shut-off (no delivery) head is on the order of 2 to 3 ft. greater than the static height "H" shown in Figure II-1.

The connecting line from the small EAS to the tank must be large enough (at least 1") so that simultaneous counter passage of air into the tank and water from the tank back to the EAS will be assured.

2. MULTIPLE BOILERS CONNECTED TO A SINGLE COMPRESSION TANK

A single tank is generally not recommended for interconnection with multiple air separators. This is because a pressure difference between the boiler will cause a flow in the header connection. This flow prevents delivery of separated air to the compression tank.

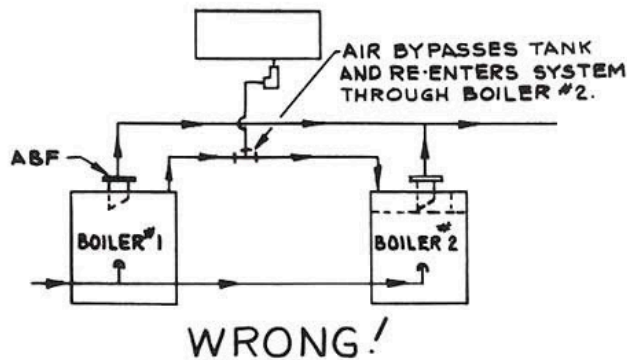

FIGURE II-2 - SINGLE TANK CONNECTION TO MULTIPLE BOILERS

The problem can be solved by a pumped header connection as schematically illustrated in Figure II-3.

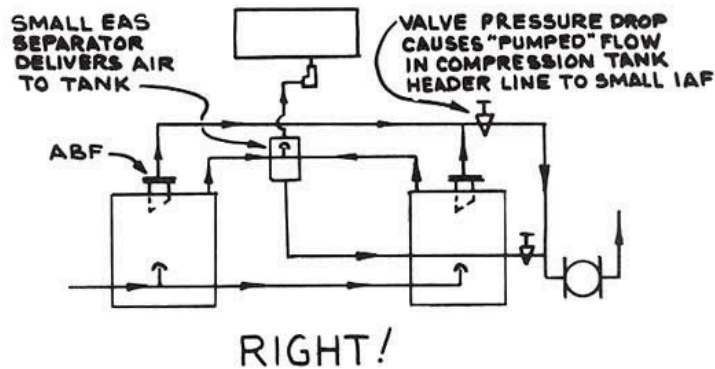

FIGURE II-3 - PUMPED COMPRESSION TANK HEADER CONTAINS SMALL EAS

The single tank can also be floor mounted as in Figure II-4.

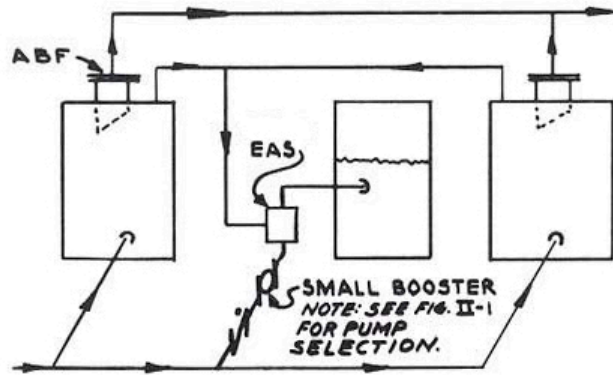

FIGURE II-4 - MULTIPLE BOILERS WITH SINGLE FLOOR MOUNTED TANK; PUMPED COMPRESSION TANK HEADER

3. MULTIPLE ZONE AIR SEPARATION

Many larger systems are installed using multiple "reset" zones. Flow distribution problems have occurred because use of a single Rolairtrol does not comply with its full system flow objective through the air separator.

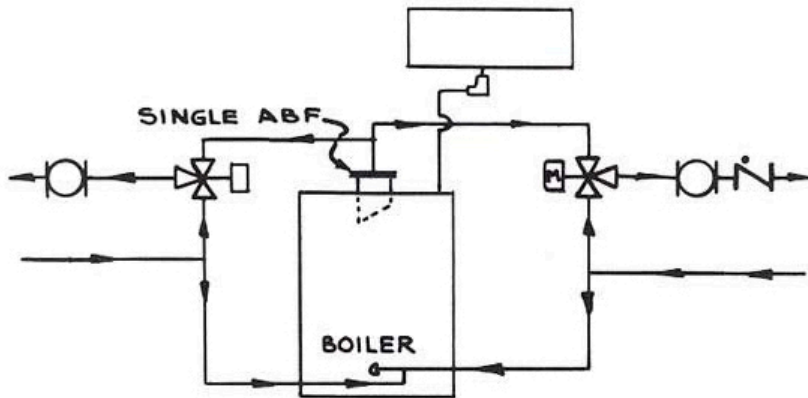

FIGURE II-5* - MULTIPLE ZONE RESET; FULL FLOW DOES NOT OCCUR THROUGH AIR SEPARATION

A separate Rolairtrol can be placed on each zone and interconnected with a single tank to meet the full flow objective.

* Piping arrangements with 3-Way control valves shown within this technical manual are provided by Bell & Gossett as reference information of existing systems only. As an active participating member of ASHRAE, it is Bell & Gossett's recommendation that engineers and system designers consult with the most current ASHRAE Standards for design guidance on Variable Flow Systems or Constant Flow Systems as indicated in ASHRAE Standard 90.1 Section 6.5.4.

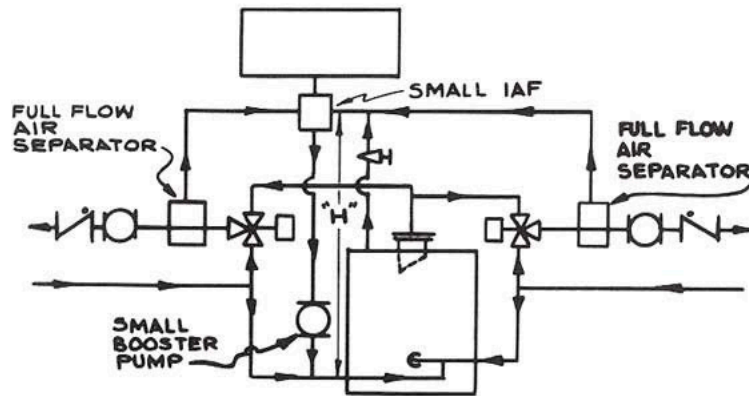

FIGURE II-6* - MULTIPLE ZONE RESET; FULL FLOW THROUGH EACH ZONE AIR SEPARATOR

The small Booster pump must have a shut-off head greater than height "H". Its head must also be greater than the three-way valve pressure drop.

III See note on page 23

IV. ZONE PIPING APPLICATIONS

1. MULTIPLE ZONE HEATING APPLICATION

The multiple zone heating application has led to many operating problems because of improper application.

One of the common problems is illustrated by an attempt to reduce cost by using a single return main for a number of zones; each zone having several circuits and several returns for each zone.

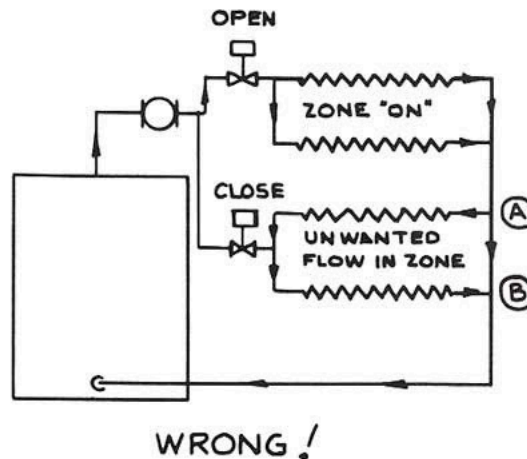
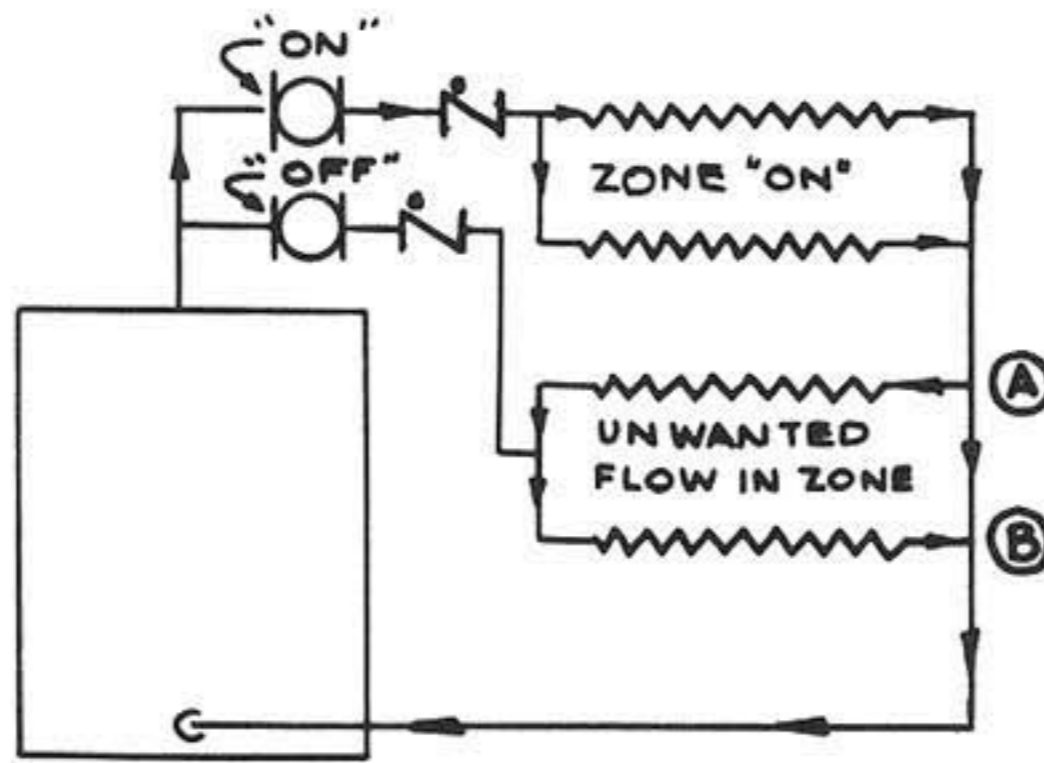

FIGURE IV-1 - MULTIPLE ZONES, VALVE CONTROLLED, EACH ZONE WITH MORE THAN ONE RETURN

* Piping arrangements with 3-Way control valves shown within this technical manual are provided by Bell & Gossett as reference information of existing systems only. As an active participating member of ASHRAE, it is Bell & Gossett's recommendation that engineers and system designers consult with the most current ASHRAE Standards for design guidance on Variable Flow Systems or Constant Flow Systems as indicated in ASHRAE Standard 90.1 Section 6.5.4.



WRONG !

FIGURE IV-2 - MULTIPLE ZONES, PUMP CONTROLLED, EACH ZONE WITH MORE THAN ONE RETURN

In both Figures IV-1 and IV-2, the operating zone causes flow rate in the return main. Pressure drop in the return (as at A and B) in turn causes unwanted flow in the non-operating zone with an associated lack of control.

On already installed systems, the only solution is to install check valve in the zone circuit returns as required.

The uncontrolled flow problems can be overcome during design by combining all zone circuit returns into a common zone return before entry into the main return.

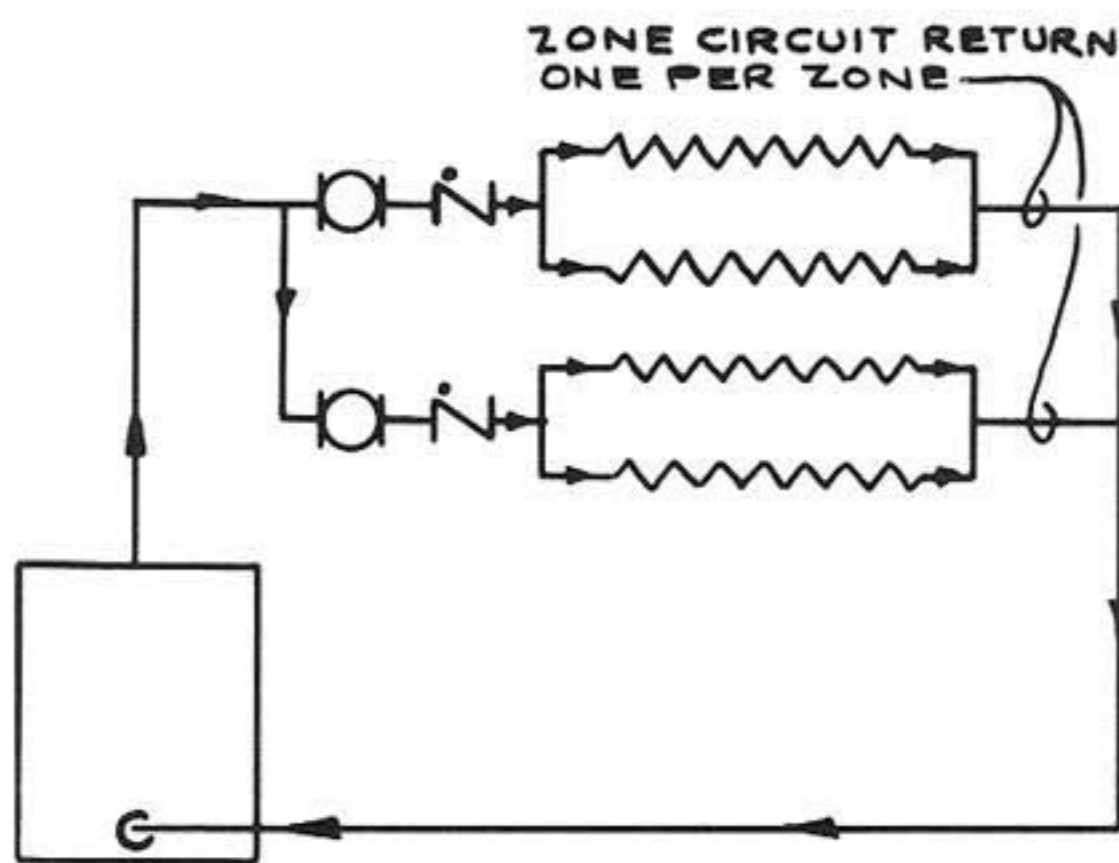

RIGHT !

FIGURE IV-3 - MULTIPLE ZONE, ONLY ONE RETURN PER ZONE

V. EQUIPMENT OR BOILER ROOM PIPING PRACTICE; HEATING

1. BOILER SHOCK PROTECTION

"Boiler Shock" is a term that has been very loosely defined. In general, it refers to sudden thermal changes inside the boiler causing rapid and uneven contractions; in turn, tending to loosen boiler tubes with a final necessity for boiler retubing.

Water tube and cast iron type boilers have, in general, a high resistance to boiler "shock". Larger fire tube type are generally more susceptible.

Boiler shock frequently occurs in large systems where week-end or night shut-down takes place.

The sudden introduction of massive amounts of cold water into the hot boiler during start-up often causes trouble.

Boiler shock can also occur in the combination heating and cooling system when switching from chilled to hot operation.

Reduced to fundamentals, control against "boiler shock" involves control of incoming "cold" water flow rate so that boiler temperatures are changed slowly.

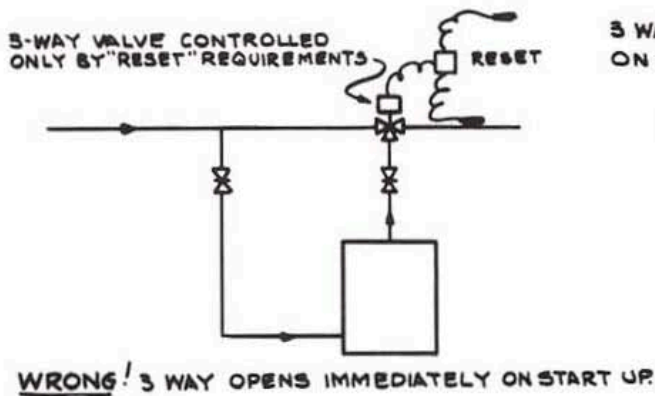

FIGURE V-1* - 3-WAY OPENS IMMEDIATELY ON START-UP

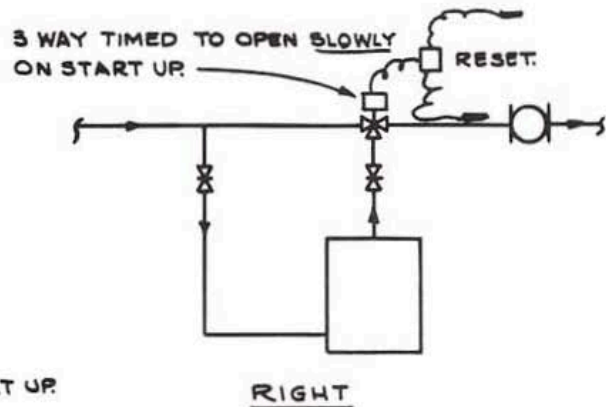

FIGURE V-2* - 3-WAY OPENING TO RESET REQUIREMENTS OVER-RIDDEN BY "TIMED" OPENING CYCLE

* Piping arrangements with 3-Way control valves shown within this technical manual are provided by Bell & Gossett as reference information of existing systems only. As an active participating member of ASHRAE, it is Bell & Gossett's recommendation that engineers and system designers consult with the most current ASHRAE Standards for design guidance on Variable Flow Systems or Constant Flow Systems as indicated in ASHRAE Standard 90.1 Section 6.5.4.

One of the methods used for "shock" protection employs a timed 3-way valve so that the boiler circuit is opened slowly to incoming cold system water. The timed cycle is generally on the order of 20 to 30 minutes from closed to fully open.

A more sophisticated arrangement provides for continuous automatic protection against boiler "shock" by separate circulation of the boiler.

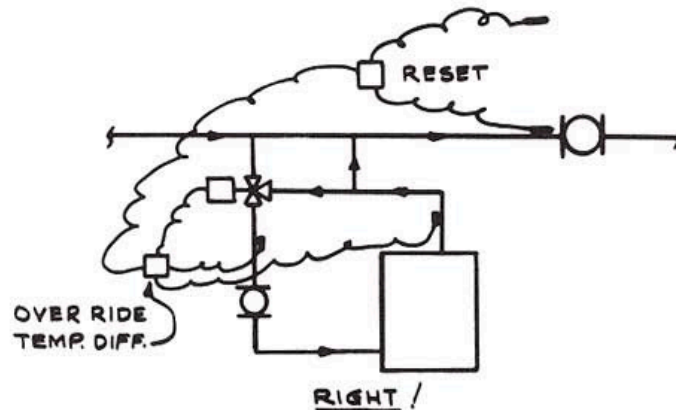

FIGURE V-3* - SEPARATELY PUMPED BOILER; 3-WAY OPENING TO RESET OVER-RIDDEN BY TEMPERATURE DIFFERENTIAL CONTROL ACROSS BOILER

In Figure V-3, the boiler is continuously circulated at a constant flow rate. The flow rate corresponding to 20° to $40^{\circ}\Delta T$ at the maximum load draw condition. On a cold start, the boiler temperature differential controls 3-way valve opening; admitting controlled amounts of "cold" system water into the boiler circuit. As the system heats up, the 3-way opens more to the system until final controlling reset is obtained.

2. RESET METHODS

Reset control can be obtained by valves alone, pumps alone or by use of valves and pumps in combination.

* Piping arrangements with 3-Way control valves shown within this technical manual are provided by Bell & Gossett as reference information of existing systems only. As an active participating member of ASHRAE, it is Bell & Gossett's recommendation that engineers and system designers consult with the most current ASHRAE Standards for design guidance on Variable Flow Systems or Constant Flow Systems as indicated in ASHRAE Standard 90.1 Section 6.5.4.

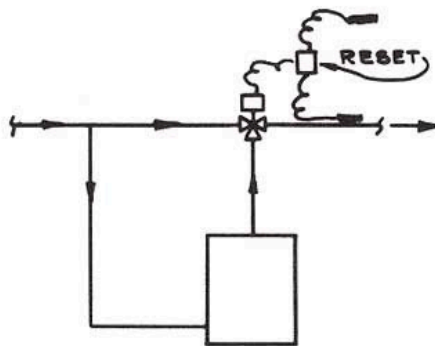

RIGHT!

FIGURE V-4* - CONVENTIONAL 3-WAY VALVE RESET APPLIED TO HEATING ONLY SYSTEM

Conventional 3-way valve reset is best used for the heating only system where, under full load, the entire system flow passes through the boiler. Under these conditions, the valve is sized to the flow it is controlling; i.e. flow from the boiler into the distribution main.

The conventional 3-way reset control is often mis-applied to combination heating and cooling systems. The mis-application concerns a fundamental proposition; that the control valve be sized to the flow it is controlling.

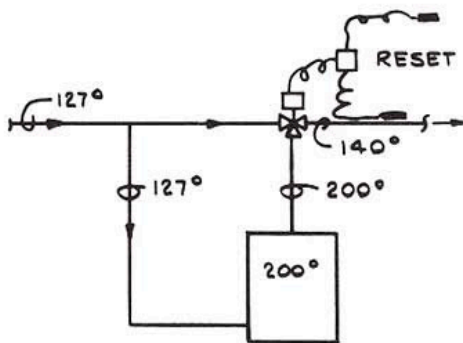

WRONG!

FIGURE V-5* - CONVENTIONAL 3-WAY RESET APPLIED TO HEAT/COOL CHANGE-OVER; VALVE SIZED TO DISTRIBUTION MAIN PIPE SIZE

In Figure V-5, the 3-way is sized to the main distribution pipe size, but is controlling the side branch boiler circuit flow. Since the boiler circuit flow requirement at full load reset is only 18% (Main ΔT or Boiler $\Delta T \frac{140-127}{200-127}$) of the main flow rate. The valve is obviously over-sized; it is sized to control, as an example, 300 GPM main flow,

* Piping arrangements with 3-Way control valves shown within this technical manual are provided by Bell & Gossett as reference information of existing systems only. As an active participating member of ASHRAE, it is Bell & Gossett's recommendation that engineers and system designers consult with the most current ASHRAE Standards for design guidance on Variable Flow Systems or Constant Flow Systems as indicated in ASHRAE Standard 90.1 Section 6.5.4.

but is used to control approximately 60 GPM boiler input flow.

The situation can be corrected with a resultant saving in valve and boiler pipe sizing as in Figure V-6.

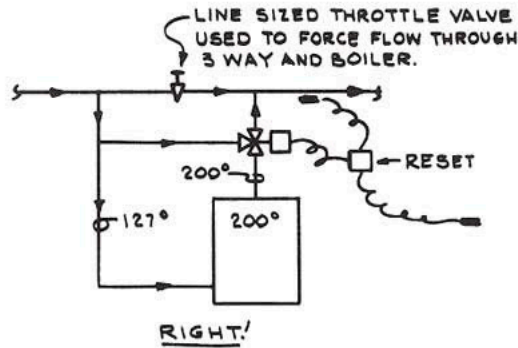

Figure V-6*- THREE WAY RESET APPLIED TO HEAT/COOL CHANGE-OVER; VALVE SIZED TO FULL LOAD BOILER CIRCUIT FLOW RATE.

Injection pumps are often used in a Primary-Secondary Boiler connection for reset.

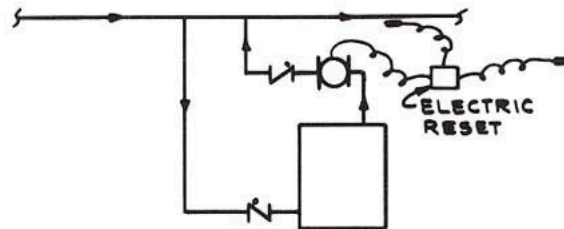

Figure V-7 - INJECTION PUMP "RESET"

The injection pump can be used for either heating only or for heat/cool application. Injection pumps are sometimes used in multiples for boiler shock protection. When used in multiples, one pump is used for light load, and other pumps are sequenced in as load increases.

* Piping arrangements with 3-Way control valves shown within this technical manual are provided by Bell & Gossett as reference information of existing systems only. As an active participating member of ASHRAE, it is Bell & Gossett's recommendation that engineers and system designers consult with the most current ASHRAE Standards for design guidance on Variable Flow Systems or Constant Flow Systems as indicated in ASHRAE Standard 90.1 Section 6.5.4.

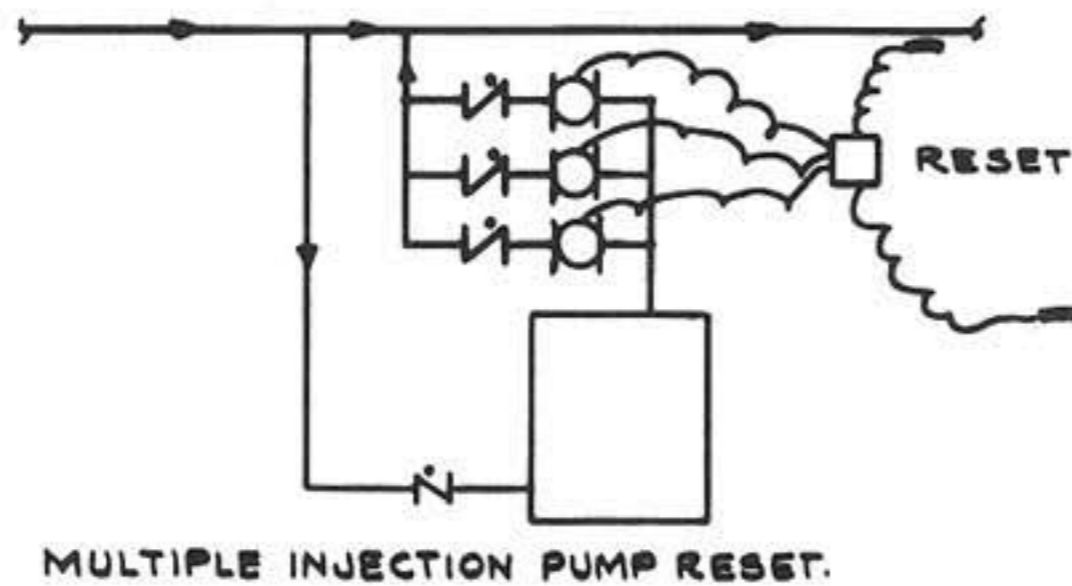

Figure V-8 - MULTIPLE INJECTION PUMP RESET

On cold start up, the pumps are gradually sequenced in until reset conditions are reached.

Multiple small boilers are also used for reset control. This particular method has the advantage of reducing boiler standby loss during light loads.

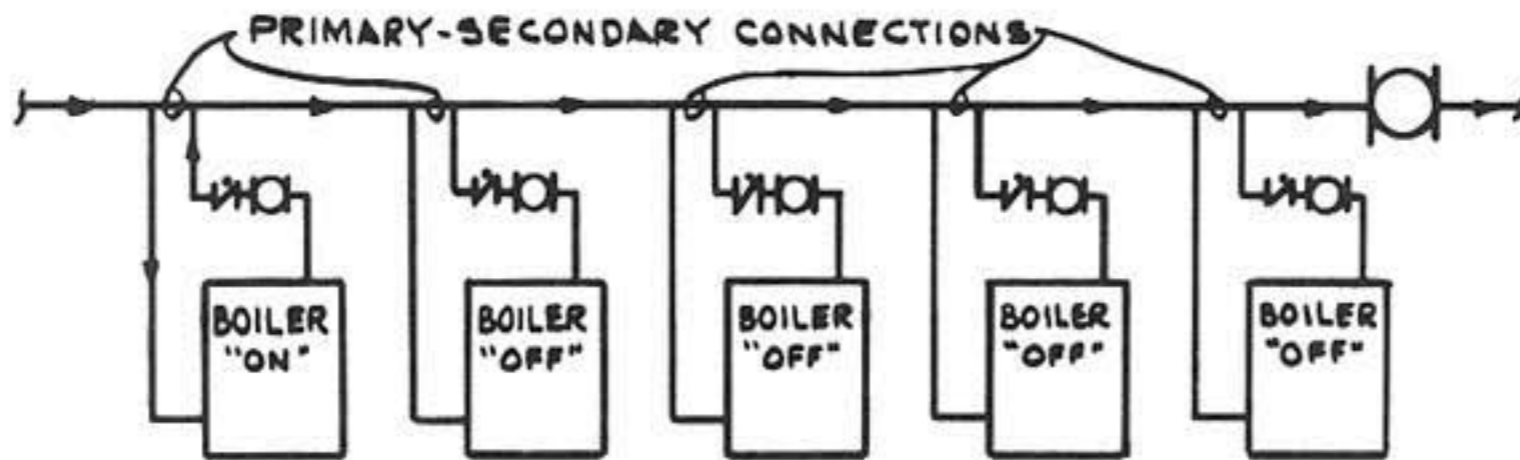

Figure V-9 - MULTIPLE BOILER RESET

In multiple boiler reset, only the operating boilers are at temperature. Standby loss is eliminated for the non-operating boilers resulting in lower operating cost. During light load, only one boiler is "on" as load or reset temperature requirements increase additional boilers are sequenced "on."

Boiler circuit pumps are often used to provide constant boiler flow, reduce control valve size and provide against boiler "shock."

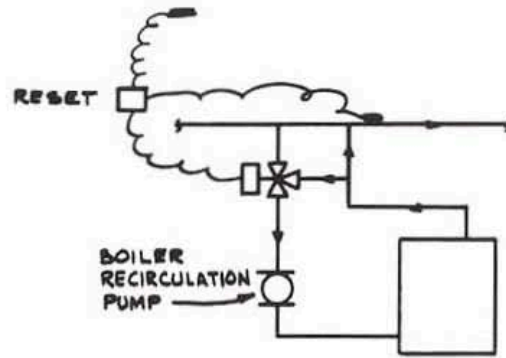

Figure V-10* - SEPARATELY CIRCULATED BOILER WITH "RESET"; BOILER SHOCK OVERRIDE NOT SHOWN (see Fig. V-3)

3. MEDIUM TEMPERATURE (250° to 300°) BOILER ROOM APPLICATION

The medium temperature system requires special consideration for its boiler room application; standard low temperature (less than 250°) piping configurations should not be used.

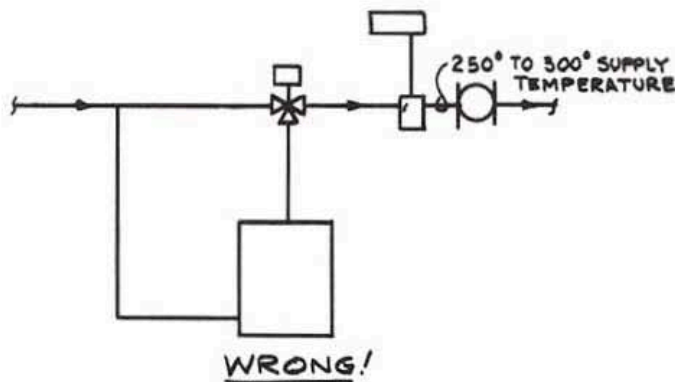

Figure V-11* - STD. LTW ARRANGEMENT SHOULD NOT BE USED FOR MTW APPLICATION

In MTW application, the main distribution pump is placed on the system return in order to reduce temperatures entering the pump.

* Piping arrangements with 3-Way control valves shown within this technical manual are provided by Bell & Gossett as reference information of existing systems only. As an active participating member of ASHRAE, it is Bell & Gossett's recommendation that engineers and system designers consult with the most current ASHRAE Standards for design guidance on Variable Flow Systems or Constant Flow Systems as indicated in ASHRAE Standard 90.1 Section 6.5.4.

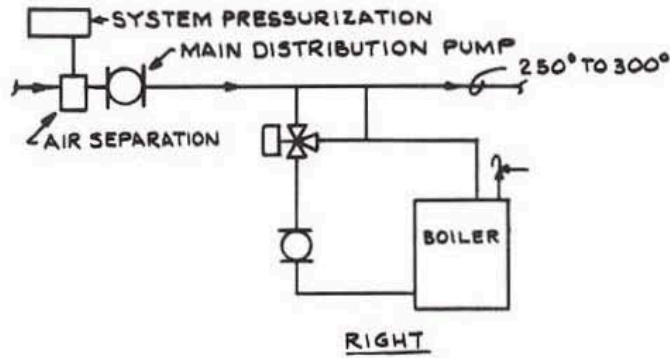

Figure V-12* - MTW BOILER ROOM ARRANGEMENT;
WATER TUBE TYPE BOILER
SEPARATELY CIRCULATED

In this arrangement, the main distribution pump is placed at the system return discharging into the water tube boiler. Constant flow is maintained in the boiler to help prevent tube burn-out.

System pressurization is set to a minimum "fill" pressure equal to a saturation pressure corresponding to 25° above maximum leaving supply temperature; 300° supply establishes 325° saturation or about 85 psig minimum fill pressure.

The boiler maximum operating pressure will be:

Minimum Fill plus system pressure rise plus pump head.

Location of the pump; discharging into boiler helps prevent boiler tube burnout.

Steam to water exchangers are often used as a heat source for MTW application.

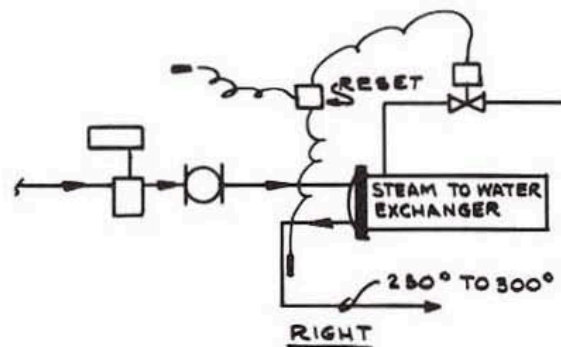

Figure V-13 - MTW BOILER ROOM ARRANGEMENT
STEAM TO WATER EXCHANGER

* Piping arrangements with 3-Way control valves shown within this technical manual are provided by Bell & Gossett as reference information of existing systems only. As an active participating member of ASHRAE, it is Bell & Gossett's recommendation that engineers and system designers consult with the most current ASHRAE Standards for design guidance on Variable Flow Systems or Constant Flow Systems as indicated in ASHRAE Standard 90.1 Section 6.5.4.

VI. EQUIPMENT OR BOILER ROOM PIPING PRACTICE - CHILLER

1. CONSTANT CHILLER FLOW

It is important, for most chillers, that a fairly constant chiller flow rate be established for good chiller load control. Unless precautions are taken chiller "short cycle" can occur with resulting chiller problems.

Changing chiller flow rates will occur with 2 way valve system control.

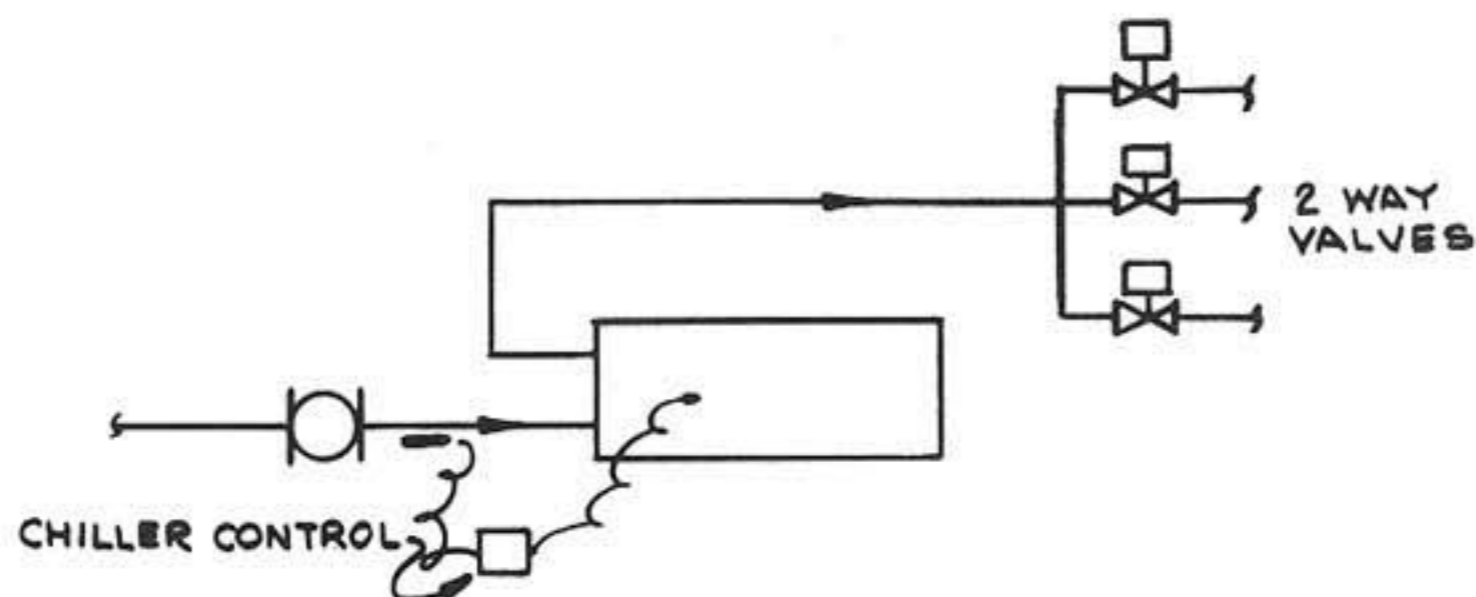

Figure VI-1 - TWO WAY VALVE CONTROL CAUSES CHILLER FLOW CHANGE

The chiller control is temperature sensitive only and will go into the same load control regardless of flow rate. For a system design to full load at 300 GPM, the temperature control will load the chiller properly only at 300 GPM. At 100 GPM flow past the chiller control point, only 1/3 load is required for any given load temperature signal. The chiller control cannot recognize the change in load caused by flow change, however, and chiller load control is upset.

The solution is to provide a relatively constant flow rate past the chiller temperature load registration point. This can be accomplished by either of two methods.

1. Separate chiller pump
2. Differential pressure controlled bypass valve.

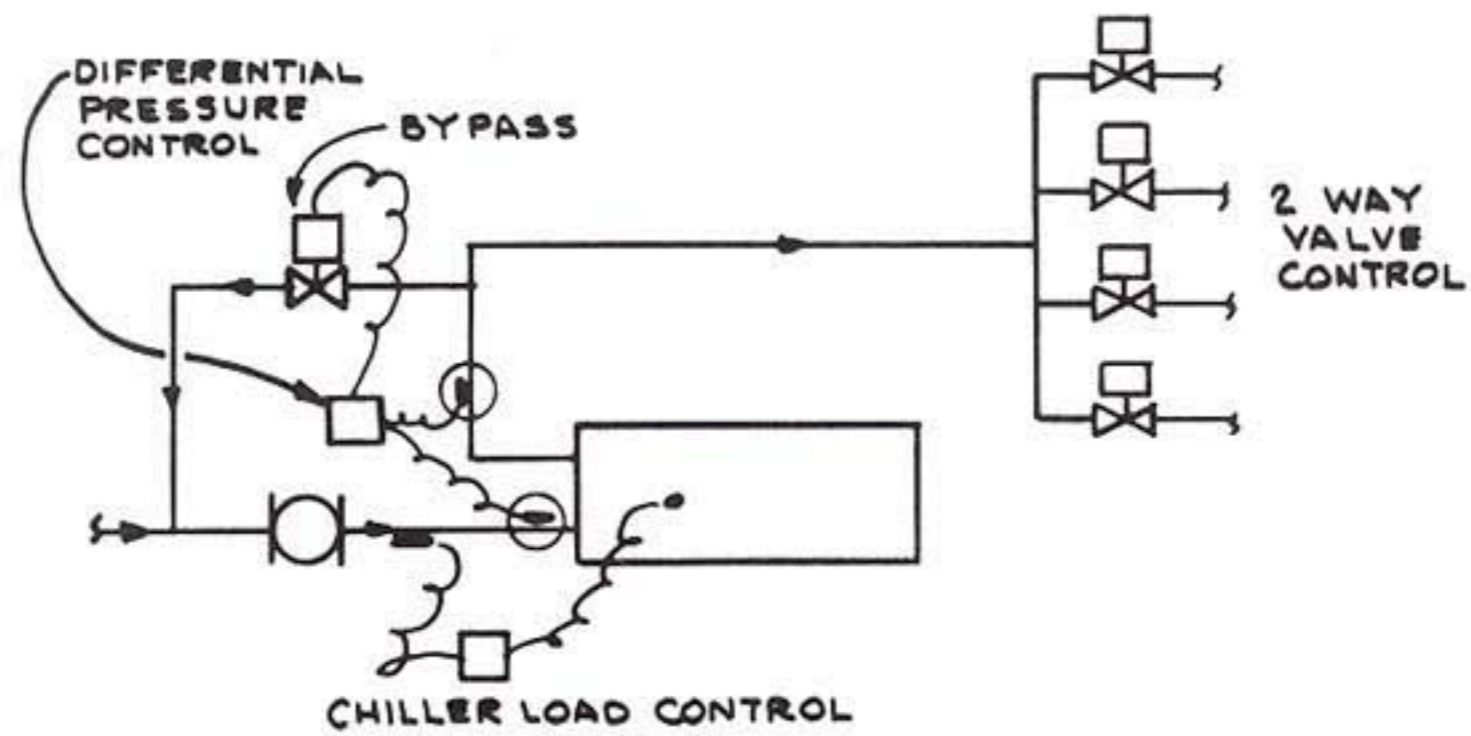
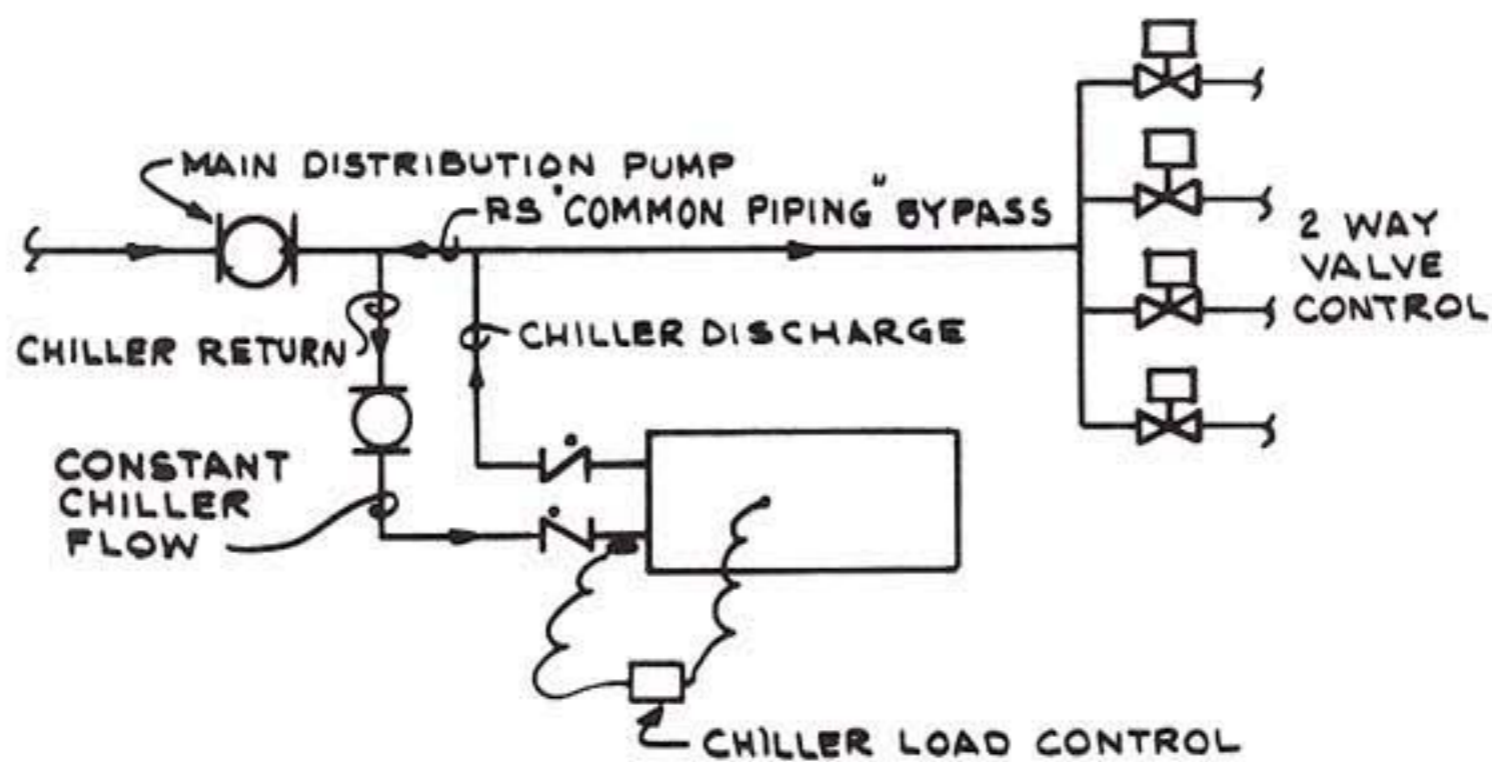

Figure VI-2 - DIFFERENTIAL PRESSURE CONTROL ACROSS CHILLER OPENS BYPASS FOR CONSTANT CHILLER FLOW.

In Figure VI-1, a constant chiller flow rate is established by differential pressure control activation of a two way bypass valve. The pressure differential controller is set to maintain a relatively constant pressure drop (constant flow).

The differential pressure control is often taken across a calibrated orifice meter, rather than the chiller itself.

The separate chiller pump is also employed to provide constant chiller flow regardless of system flow change.



RIGHT!

Figure VI-3 - CONSTANT CHILLER FLOW ESTABLISHED BY SEPARATE CHILLER PUMP.

The separate chiller pump provides constant flow rate through the chiller regardless of system flow rate.

When system flow rate reduces to less than chiller flow rate, bypass flow from chiller discharge to chiller return occurs through the common piping. A mixture of system return with chiller discharge water occurs so that a true load statement is made to the chiller control device in terms of entering chiller temperature.

The separate chiller pump removes chiller P.D. from system pumping considerations. Removal of the chiller P.D. increases 2 way valve control effectiveness because of a reduction in the main distribution pump head.

The separately circulated chiller, with slight modification, permits use of the chiller to "cool down" hot distribution mains while controlling inlet chiller water temperatures.

2. Immediate "cool down" of hot distribution main, Primary-Secondary-Separate Chiller Pump.

A common operational problem with combination heating-cooling systems concerns switch over from heating to cooling when residual system water temperatures are too high (over 90°) to permit instant chiller start up.

The separately circulated chiller can be used to "cool down" the hot system water by mixing of chiller discharge water with main system water to provide allowable chiller entry temperatures.

Either of two methods can be used:

1. Constant chiller flow; reduced main flow.
2. Constant chiller flow; constant system flow with controlled "bleed" flow.

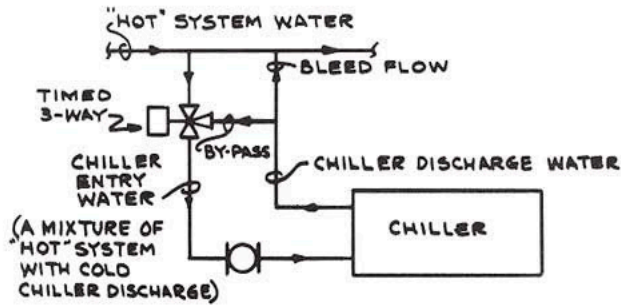

Figure VI-4* - TIMED 3 WAY VALVE APPLIED TO SYSTEM COOL DOWN

In this arrangement, a three way valve is time cycled to open from full open bypass to bypass closed in about 20 Min. (time dependent on system water volume and temp.)

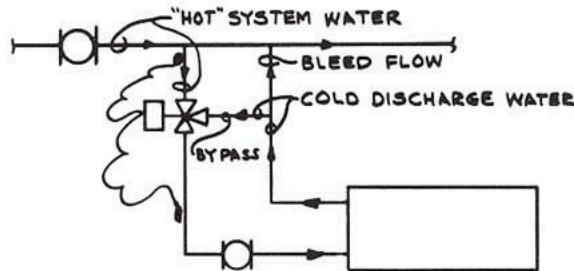

Figure VI-5* - THREE WAY VALVE, CONTROLLED FROM CHILLER INLET TEMPERATURE

In figure VI-5, the three way valve is set so as to open to bypass when inlet temperatures are over 90° and to close to bypass when inlet temperature is less then 80°.

The three way would be controlled by master, sub master controllers so arranged so as to decrease bypass flow and increase system "bleed" flow as system water temperature is decreased by chiller operation.

When system water temperature is reduced to less than 80°, the valve closes completely to bypass and normal system operation occurs.

Another, and very simple arrangement, makes use of a small change-over distribution pump applied in parallel with the main distribution pump.

* Piping arrangements with 3-Way control valves shown within this technical manual are provided by Bell & Gossett as reference information of existing systems only. As an active participating member of ASHRAE, it is Bell & Gossett's recommendation that engineers and system designers consult with the most current ASHRAE Standards for design guidance on Variable Flow Systems or Constant Flow Systems as indicated in ASHRAE Standard 90.1 Section 6.5.4.

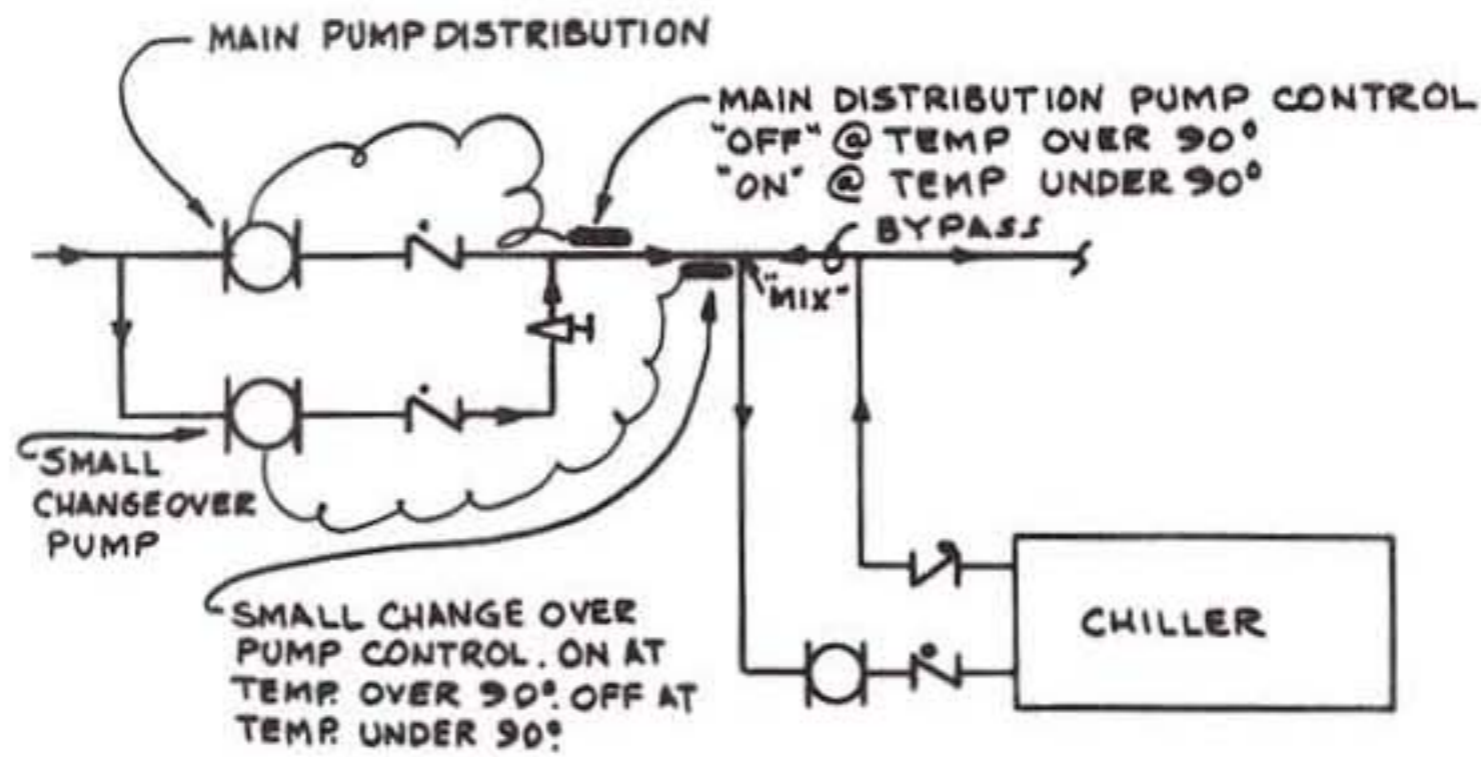

Figure VI-6 - CHANGE OVER PUMP; OPERATION CONTROLLED FROM SYSTEM WATER TEMPERATURE

The changeover pump illustration above will generally be a small booster pump providing a system flow rate less than chiller flow rate.

Since system flow rate is less than chiller flow, a continuous bypass flow occurs in the Primary-Secondary bypass mixing with system water to provide mixed chiller entry water that is less than 90°.

When system water temperature decreases to 90°, the main distribution pump is energized and normal system operation takes place.

VII. EQUIPMENT ROOM PUMPING HEATING/COOLING

1. Standby Pump Provision

Most large heating-cooling systems have standby pump provision.

A common standby method is illustrated below:

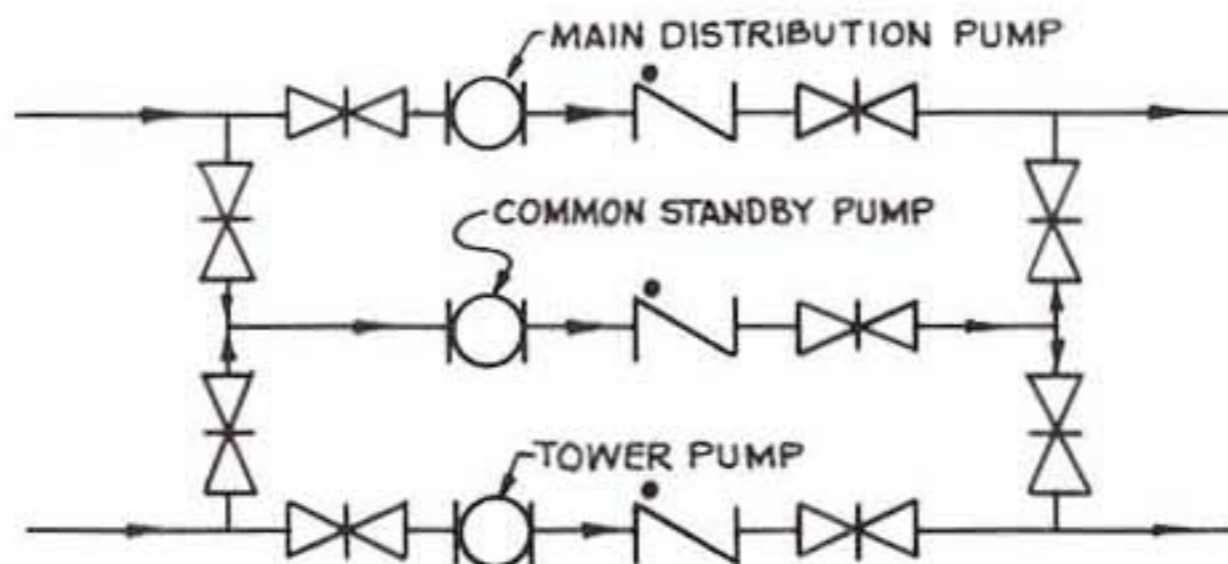

Figure VII-1 - COMMON STANDBY; STANDBY SERVES BOTH TOWER AND SYSTEM DISTRIBUTION

The common standby pump is selected to the greater flow requirement; usually tower pump and is checked against distribution head requirement by use of system curve analysis for actual standby system distribution flow.

2. Paralleled Chiller; Each Chiller with its own Pump.

On some larger systems, chillers are placed in parallel; each chiller having its own circulation pump, which is also applied to system distribution. As load increases chillers are placed on the line, as load decreases chillers and their pumps are cut off.

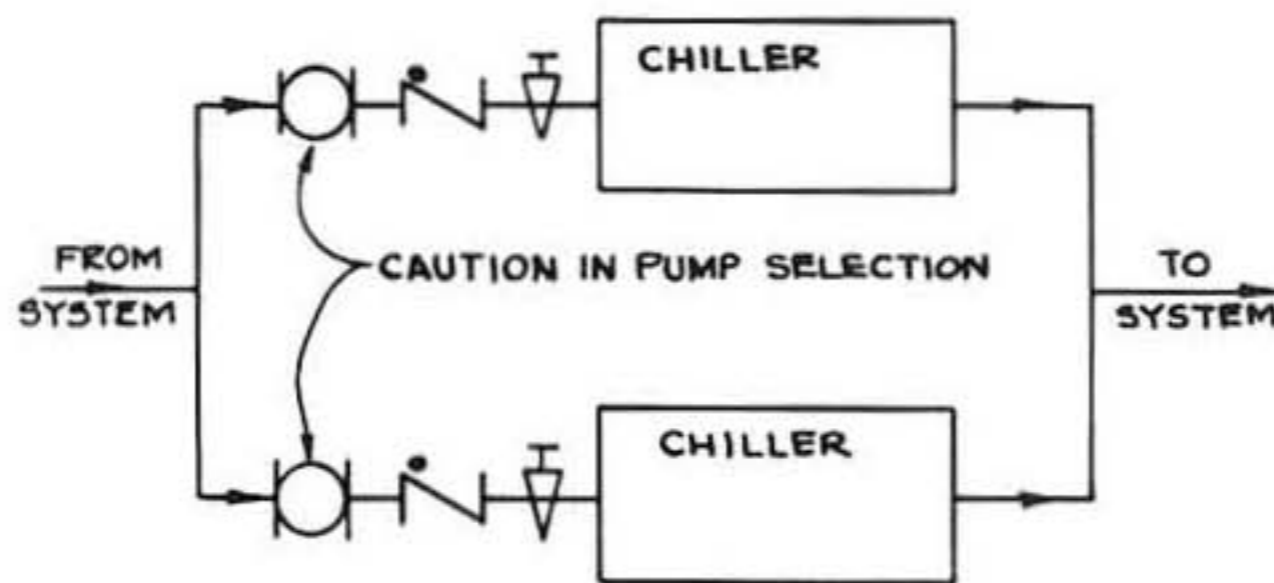

Figure VII-2 - PARALLEL CHILLERS; EACH CHILLER WITH PUMP

Caution must be applied in pump selection and operation for this arrangement. The pump selection can be easily made for full load operation; with both chillers and their pumps in operation. As an example:

Pump selection is to be made for parallel chillers; each with its own pump. Each chiller has 20 ft. P.D. at 200 GPM. The piping system, exclusive of the chillers, has 80 ft. P.D. at 400 GPM.

The selection point for each pump is then 100 ft. head at 200 GPM. A "system curve" can be struck for each pump using the "point" 100 ft. @ 200 GPM.

When only a single chiller is in operation, however, a new set of circumstances is faced by the single operating pump. The revised "system curve" for single pump operation can be developed by referencing piping system P.D. (P.D. exclusive of chiller) to single chiller flow and adding piping system P.D. and chiller P.D. at a common flow rate; usually design chiller flow rate. In this case:

Reference to both Chillers; System Piping P.D. = 80' @ 400 G.P.M.

Reference to single Chiller; System Piping P.D. = 20' @ 200 G.P.M.

The total revised system curve for the single pump and chiller will then be:

Chiller P.D. = 20' @ 200 G.P.M.

Piping P.D. = 20' @ 200 G.P.M.

Total System = 40' @ 200 G.P.M.

A system curve developed through 40' @ 200 G.P.M. will yield required information for operation of the single chiller.

III EQUIPMENT OR BOILER ROOM PRESSURIZATION
PROBLEMS; HEATING AND/OR COOLING
Note (to be added in Appendix)



Xylem Inc.
8200 N. Austin Avenue
Morton Grove, Illinois 60053
Phone: (847) 966-3700
Fax: (847) 965-8379
www.bellgossett.com