



E70-650 SPC (DEC 2005)

File: EQUIPMENT MANUAL - Section 70
Replaces: NOTHING (New Information)
Dist: 10

ROTARY SCREW COMPRESSORS

Models SGC 1913 through 2824

Models SGCH / SGCB 3511 through 3524



SGC 1913 - 2824



SGCH / SGCB 3511 - 3524

FEATURES AND BENEFITS

The Frick® SGC & SGCB screw compressors are designed to compress a variety of gases in many different applications including refrigeration, air conditioning, water chilling, well-head compression, gas gathering, and vapor recovery. Applications include booster duty (low temperature/pressure), high (single) stage, or swing duty compression.

Stepless Capacity Control - A hydraulically actuated slide valve moves axially along the rotor mesh line to provide infinite unloading down to approximately 10% of full load capacity for most models. Unloaded gas is bypassed back to suction before compression has begun, allowing the compressor to efficiently accommodate system requirements. External piping is dramatically reduced by cylinder mounted solenoid control valves.

Variable Volume Ratio - A hydraulically actuated slide stop adjusts slide valve length to optimize internal discharge pressure. This matches compressor volume ratio to system pressure ratio and eliminates the power penalties associated with under- or overcompression.

Indicator Transmitters - Hermetically sealed Indicator Transmitters eliminate refrigerant contact.

Antifriction Bearings - Cylindrical roller bearings handle radial loads, and four-point angular contact ball bearings, aided by balance pistons, absorb thrust loads. No preload is required. At design conditions, L10 life is in excess of 100,000 hours. Roller bearings also maintain superior rotor positioning to minimize internal leakage and provide excel-

lent performance. System differential pressure is normally sufficient as the driving force to supply oil to the bearings, thereby eliminating the need for an oil pump. Antifriction bearings have lower frictional horsepower requirements for lower power consumption. Compressor housings are machined to provide static oil reservoirs for the bearings.

Built-In Suction Strainer - Model 19xx through 28xx has an integrated suction strainer with side access on left or right.

Drive and Motor Arrangement - These compressors have an optional tunnel for direct mount to flange drivers which supplies optimum alignment, maximum shaft seal life, and low noise.

Oil Injection - Injected oil serves to lubricate the bearings, balance piston, and seal, fill any leakage paths between and around the rotors to prevent gas bypassing, and maintain superior efficiencies. Oil injection minimizes noise and vibration. It keeps the compressor cool to prevent overheating by absorbing much of the heat from compression.

Oil Passages - Internally machined oil passages reduce the risk of leaks inherent in external piping.

Made in the USA - The entire compressor is designed and built by Frick® in Waynesboro, PA. Expert engineering, automated machining centers, clean temperature controlled assembly, and stringent quality control requirements, all contribute to ensuring easy installation, reliable operation, and convenient servicing.

MATERIALS OF CONSTRUCTION

Castings - ASTM A48 class 40 gray cast iron or equivalent is standard for pressure-retaining parts. Suction and discharge flanges comply with ANSI B16.1. A 300 class suction is standard for all models. A 300 class discharge flange is standard on all models. An alternate casing material is ASTM A536 grade 65-45-12 ductile (nodular) iron.

Rotors - AISI 1141 low carbon steel.

Bearings - Rolling elements and rings are AISI 52100 medium carbon alloy steel. Cages are brass, polyamide, or steel. Tolerance quality complies with ABEC 1 through 3.

Slide Valve Spindle - AISI 1141 low carbon steel.

Slide Valve Indicator Rod - Type 416 stainless steel.

Slide Stop Indicator Rod - Type 304 stainless steel.

Pistons, Spacers, Etc. - Gray cast iron, A516 steel plate, regular carbon steel plate, or various types of hot rolled, cold rolled or cold drawn steel bar.

Retaining (Snap) Rings & Spring Washers - High carbon spring steel.

Bolts - Grade 8.8, heat treated, medium carbon steel, socket head cap screws.

Static Seals - HNBR O-rings. Viton also available.

Dynamic Seals - Carbon filled teflon.

Shaft Seal - Spring-loaded stationary carbon end face rides in a stainless steel carrier against a rotating nonmagnetic cast iron alloy (Ni-resist) floating seat. The assembly is fully balanced and capable of sealing high pressure, but is vented to low pressure to extend seal life. Secondary seals are HNBR or viton O-rings. Alternate seal designs and materials are available for some applications.

TYPICAL PERFORMANCE

Model	R-22 (HCFC)				Ammonia (R-717, NH ₃)				Natural Gas (SG=.65, k=1.26)			
	Capacity		Power		Capacity		Power		Capacity		Power	
	TR	KW	BHP	KW	TR	KW	BHP	KW	MMSCFD	MSCMH	BHP	KW
1913	206	724	229	171	213	749	235	175	0.644	0.759	47	35
1918	275	965	306	228	284	999	314	234	0.859	1.013	62	47
2313	365	1284	399	298	384	1351	410	306	1.000	1.178	82	61
2317	460	1617	503	375	483	1699	517	386	1.385	1.632	104	78
2321	568	1998	621	463	598	2103	638	476	1.711	2.016	128	96
2813	654	2301	715	533	688	2420	736	549	1.990	2.344	149	111
2817	824	2897	901	672	866	3046	926	691	2.506	2.952	187	140
2821	991	3486	1084	808	1044	3673	1117	833	3.015	3.552	225	168
2824 ⁽⁵⁾	-	-	-	-	-	-	-	-	3.410	4.021	246	183
3511	1014	3566	1142	852	1066	3748	1169	872	3.191	3.759	233	174
3515	1383	4863	1558	1162	1453	5111	1594	1189	4.352	5.127	318	237
3519	1760	6190	1982	1478	1850	6505	2032	1515	5.539	6.525	405	302
3524 ⁽⁶⁾	-	-	-	-	-	-	-	-	6.979	8.230	510	381

Notes:

1. SG=Specific Gravity, k=Ratio of Specific Heats (Cp/Cv), TR=Tons Refrigeration, KW=Kilowatts, BHP=Brake Horsepower, MMSCFD=Million Standard Cubic Feet per Day, MSCMH=Thousand Standard Cubic Meters per Hour.
2. R-22 ratings based on 20°F (-6.7°C) suction and 95°F (35°C) condensing with 10°F(5.5°C) liquid subcooling and 10°F(5.5°C) suction superheat at 3550 RPM.
3. R-717 ratings based on 20°F (-6.7°C) suction and 95°F (35°C) condensing with 10°F(5.5°C) liquid subcooling and 10°F(5.5°C) suction superheat at 3550 RPM.
4. Natural gas ratings based on 25 PSIA (172 kPaA), 80°F (27°C) suction and 75 PSIA (517 kPaA) discharge at 1750 RPM.
5. SGC 2824 used mainly as a booster but can also run certain high stage applications.
6. SGCB 3524 is used only for booster applications and gas compression.

DESIGN LIMITATIONS AND MECHANICAL CHARACTERISTICS

	SGC MODEL									SGCH / SGCB MODELS			
	1913	1918	2313	2317	2321	2813	2817	2821	2824	3511	3515	3519	3524
Approx Compr. Wt. lb (kg)	1720 (780)	1895 (860)	2670 (1210)	2950 (1340)	3300 (1500)	4100 (1860)	4400 (2000)	4700 (2136)	5100 (2315)	7200 (3400)	8240 (3740)	9200 (4172)	10,200 (4625)
Rotor Dia. mm	193		233			283			355				
Drive Arrangement	Directly driven by the male rotor in the clockwise direction as viewed from the driver												
Minimum Driver Speed ⁽¹⁾⁽²⁾ RPM	600												
Maximum Driver Speed RPM	4500					3600							
Max. Input Power to Rotor Shaft BHP (KW)	450 (336)		750 (559)			1400 (1044)			3500 (2609)				
Min. Breakaway Torque ft-lb (Nm)	10 (13.5)		14 (19.0)			20 (27.1)			25 (33.9)				
Mass Moment of Inertia ⁽³⁾ ft ² -lb _m (m ² -kg)	5.1 (.21)	6.5 (.27)	13 (.55)	16 (.67)	18 (.77)	33 (1.4)	41 (1.7)	48 (2.0)	56 (2.4)	97 (4.1)	110 (4.8)	135 (5.7)	154 (6.5)
Suction Flange in. (mm)	5 (127)	6 (152)		8 (203)				10 (254)		14 (356)			
Discharge Flange in. (mm)	4 (102)		6 (152)			8 (203)			10 (254)				
Theoretical Displacement ft ³ /rev. (m ³ /rev.)	.16653 (.004716)	.22204 (.006240)	.29301 (.008297)	.36897 (.01045)	.45580 (.01291)	.52501 (.01487)	.66113 (.01872)	.79546 (.02253)	.89857 (.02545)	.82248 (.02329)	1.12160 (.03177)	1.42750 (.04042)	1.80316 (.05106)
Displ. at 3550 rpm Driver Speed ft ³ /min (m ³ /hr)	591 (1004)	788 (1339)	1040 (1767)	1310 (2225)	1618 (2749)	1864 (3167)	2347 (3988)	2824 (4798)	3190 (5420)	2920 (4961)	3982 (6765)	5068 (8610)	6401 (10,875)
Displ. at 2950 rpm Driver Speed ft ³ /min (m ³ /hr)	491 (835)	655 (1113)	864 (1468)	1088 (1849)	1345 (2284)	1549 (2631)	1950 (3314)	2347 (3987)	2651 (4504)	2426 (4122)	3309 (5621)	4211 (7155)	5319 (9037)
Displ. at 1750 rpm Driver Speed ft ³ /min (m ³ /hr)	291 (495)	389 (660)	513 (871)	646 (1097)	798 (1355)	919 (1561)	1157 (1966)	1392 (2365)	1573 (2673)	1439 (2445)	1963 (3335)	2498 (4244)	3156 (5361)
Displ. at 1450 rpm Driver Speed ft ³ /min (m ³ /hr)	242 (410)	322 (547)	425 (722)	535 (909)	661 (1123)	761 (1293)	959 (1629)	1153 (1960)	1303 (2214)	1192 (2026)	1626 (2763)	2072 (3517)	2615 (4442)
Capacity Control	Infinitely adjustable from 100% to aprox. 10% (15% for 2824 & 3519)(20% for 3524)												
Volume Ratio	Infinitely adjustable from 5.0 to 2.2 (2824 - 4.1 to 2.0)(3524 - 4.5 to 2.2)												
Max. Inlet Press. psia (bara)	150.0 (10.3)												
Max. Outlet Press. psia (bara)	400.0 (27.6)												
Minimum Inlet Temp. ⁽⁴⁾ °F (°C)	-76.0 (-60.0)												
Maximum Inlet Temp. °F (°C)	200.0 (93.3)												
Maximum Outlet Temp. °F (°C)	250.0 (121.1)												
Maximum Temp. Dif. (Suct. to Disch.) °F (°C)	250.0 (138.9)												
Max. Bearing Oil Supply Temp. °F (°C)	230.0 (110.0)												

1. Contingent upon compression ratio, bearing L10 limitations, oil viscosity, and other operating conditions.
2. Compressor suction flow may be zero at full unload slide valve position below 1800 RPM (1200 for 355).
3. Does not include coupling. Resolved to drive shaft.
4. At compressor suction flange. Minimum evaporator temperature can be lower.

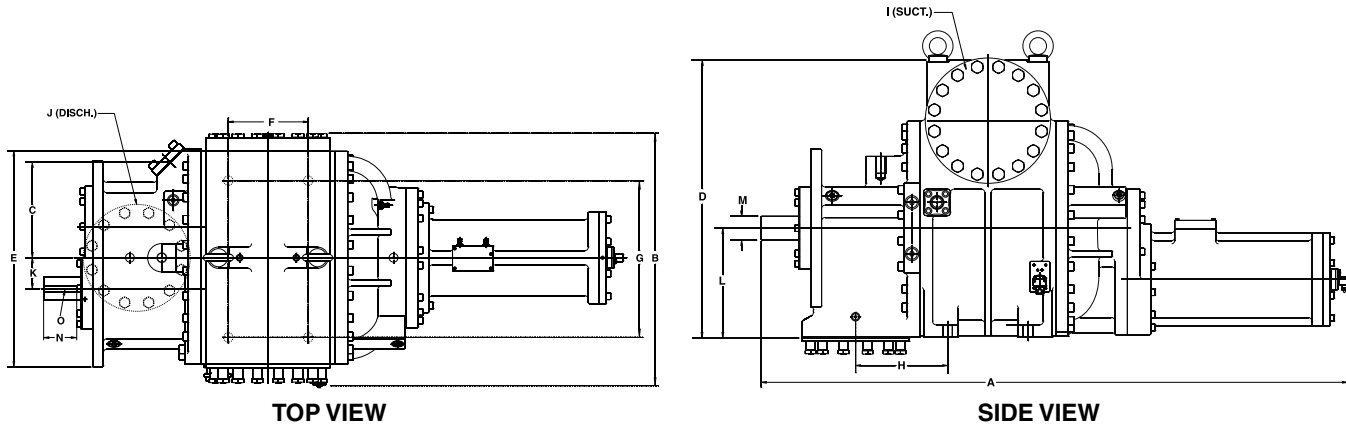

DIMENSIONAL OUTLINE

APPROXIMATE DIMENSIONS		SGC								
		1913	1918	2313	2317	2321	2813	2817	2821	2824
A	in. (mm)	56.90 (1445.3)	60.32 (1532.1)	65.18 (1655.6)	68.39 (1737.1)	78.76 (2000.6)	77.94 (1979.7)	81.84 (2078.8)	93.80 (2382.5)	98.46 (2500.9)
B	in. (mm)	27.50 (698.5)	28.04 (712.2)	28.60 (726.4)	29.83 (757.7)	29.89 (759.2)	34.71 (881.6)	35.46 (900.7)	35.53 (1346.2)	
C	in. (mm)	9.98 (253.5)		10.98 (278.8)			13.46 (341.9)			
D	in. (mm)	26.30 (668.0)	27.80 (706.1)	32.12 (815.8)	33.12 (841.2)	33.12 (841.2)	37.00 (939.8)	39.00 (990.5)		
E	in. (mm)	22.86 (580.7)		26.10 (662.9)			26.29 (667.7)			
F	in. (mm)	4.92 (125.0)	8.34 (211.8)	6.52 (165.6)	9.72 (246.9)	13.40 (340.4)	7.31 (185.7)	11.21 (284.7)	15.67 (397.9)	19.02 (483.1)
G	in. (mm)	16.54 (420.1)		20.12 (511.0)			22.00 (558.8)			
H	in. (mm)	8.19 (208.1)		9.58 (243.2)			12.88 (327.2)			
I	in. (mm)	5.00 (127.0)	6.00 (152.4)		8.00 (203.2)			10.00 (254.0)		
J	in. (mm)	4.00 (101.6)		6.00 (152.4)			8.00 (203.2)			
K	in. (mm)	2.98 (75.7)		3.60 (91.4)			4.37 (111.0)			
L	in. (mm)	11.42 (290.1)		12.87 (326.9)			15.25 (387.3)			
M	in. (mm)	2.25 (57.2)		2.50 (63.5)			3.25 (82.6)			
N	in. (mm)	3.75 (95.3)		3.81 (96.8)			5.00 (127.0)			
O	in. (mm)	.50 (12.7)		.63 (15.9)			.88 (22.2)			

Notes:

1. A 2817 is shown for illustrative purposes only. Configurations of other compressor sizes vary slightly.
2. Model 19xx - 28xx has an integrated suction strainer with side access on left or right.

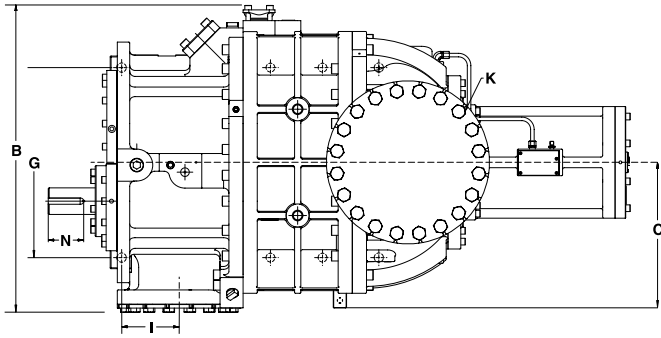

TOP VIEW

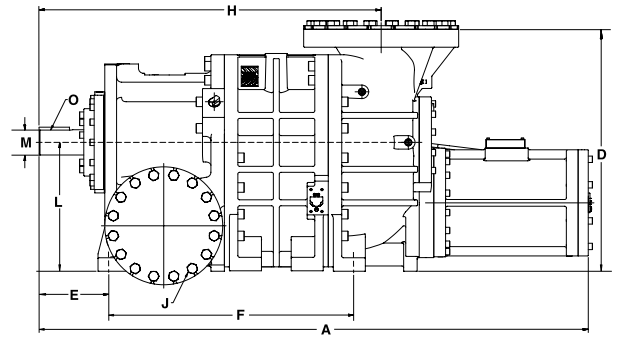

SIDE VIEW

DIMENSIONAL OUTLINE

APPROXIMATE DIMENSIONS		SGCH / SGCB			
		3511	3515	3519	3524
A	in. (mm)	81.49 (2069.7)	87.08 (2211.8)	92.68 (2353.9)	99.69 (2532.2)
B	in. (mm)	43.32 (1100.3)	42.07 (1068.6)		
C	in. (mm)	20.54 (521.8)			
D	in. (mm)	35.87 (911.2)			
E	in. (mm)	10.36 (263.2)		10.37 (263.3)	
F	in. (mm)	36.55 (928.2)	42.14 (1070.3)	47.73 (1212.4)	54.75 (1390.6)
G	in. (mm)	27.00 (685.8)			
H	in. (mm)	50.76 (1289.2)	56.36 (1431.3)	61.95 (1573.5)	68.97 (1751.7)
I	in. (mm)	8.13 (206.5)			
J	in. (mm)	10.00 (254.0)			
K	in. (mm)	5.47 (139.0)			
L	in. (mm)	19.12 (485.7)			
M	in. (mm)	3.75 (95.3)			
N	in. (mm)	5.00 (127.0)			
O	in. (mm)	.875 (22.2)			

Notes:

1. A 3511 is shown for illustrative purposes only. Configurations of other compressor sizes vary slightly.
2. 355 size compressors have a side discharge arrangement. The flange is located on the right side of the outlet housing as viewed from the driver.
3. The drive end mounting holes in model 355 compressors are located inboard of the discharge flange with respect to the drive shaft.
4. Suction strainer and housing not integrated in models 35xx.

NOTES



NOTES

NOTES