

Service Information



Date: July 6, 2011

Ref. No.: NS-12-11

To: Service Manual Holders
National, International, Canada
Field Sales and Waynesboro Personnel

Subject: Vibration Services and New Report Format

Beginning June 15, 2011 vibration analysis reports will have a different look and an improved format.

New Vibration Reports- improved pricing, improved readability, more concise, less paper and easier to understand.

What is Different?

New Cover Page-Improvements

- *Added column for plant equipment designation*
- *Removed severity code*
- *Added status code-3 designations*
 - *Problem Detected (See Report)-Color Coded to match Overall condition on report*
 - *No Reading Taken [machine out of service]*
 - *No Problem Detected*
- *Cover page will include a last measurement report for each piece of equipment which shows overall values for last measurement, previous measurement, and percentage change.*

Vibration Reports- Improvements

- *Only equipment with "Problem Detected" status will have a written vibration report published.*
- *Reports will be more concise and limited to two pages.*
 - *Overall condition color coded at top of page*
 - *Customer and Equipment reference data in one location*
 - *Has plot of overall machine history*
 - *Has Fault Summary, Analysis, and Recommendation sections*
 - *A machine outline with problem area highlighted*
 - *Vibration spectrum plots, Wave form or other plots as required to illustrate problem*
- **All** equipment vibration readings, whether a problem detected or not, are kept in data base for reference and historical information.
- Later this year it is planned to make these reports available on line.

Best Regards,

A handwritten signature in black ink that reads "Steve R. Swope".

Steve Swope
Manager of Aftermarket & Customer Service
Johnson Controls / Frick

The Frick logo, featuring the word "Frick" in a bold, black, sans-serif font with a small blue asterisk above the letter "i".

BY JOHNSON CONTROLS

**Compressors • Condensers • Controls • Evaporators
Air Handlers • Heat Exchangers • Vessels • Packaged Equipment**

100 CV Avenue • Waynesboro, PA USA 17268-1206

Phone: (717) 762-2121 • Fax: (717) 762-8624 • www.johnsoncontrols.com/frick



BY JOHNSON CONTROLS

Customer Name

Customer Location

Machine	Date data taken	Overall Condition
RWFII-270	June 9, 2011	Alarm
RWBII-222	June 9, 2011	Acceptable

Last Measurement Report

Source: Customer Name/Location

6/23/2011 2:00:18 PM

#6 Mtr RWBII-222

Last Measurement

<u>POINT name</u>	<u>Date</u>	<u>Last value</u>	<u>Previous value</u>	<u>Units</u>	<u>% change</u>
% OF FULL LOAD AMPS	6/9/2011	61.990	---	% LOAD	---
MOH VEL 400Hz	6/9/2011	0.229	---	in/s	---
MOH VEL 3KHz	6/9/2011	0.212	---	in/s	---
MOH ACC	6/9/2011	1.656	---	g	---
MOH,TW	6/9/2011	3.360	---	g	---
MOV VEL 400Hz	6/9/2011	0.245	---	in/s	---
MOV VEL 3KHz	6/9/2011	0.288	---	in/s	---
MOV Env	6/9/2011	9.084	---	gE	---
MOA VEL 400Hz	6/9/2011	0.222	---	in/s	---
MOA VEL 3KHz	6/9/2011	0.258	---	in/s	---
MIH VEL 400Hz	6/9/2011	0.213	---	in/s	---
MIH VEL 3KHz	6/9/2011	0.243	---	in/s	---
MIH ACC	6/9/2011	2.824	---	g	---
MIH,TW	6/9/2011	3.840	---	g	---
MIV VEL 400Hz	6/9/2011	0.120	---	in/s	---
MIV VEL 3KHz	6/9/2011	0.146	---	in/s	---
MIV Env	6/9/2011	5.569	---	gE	---
MIA VEL 400Hz	6/9/2011	0.220	---	in/s	---
MIA VEL 3KHz	6/9/2011	0.241	---	in/s	---

#6 TDS RWBII-222

Last Measurement

<u>POINT name</u>	<u>Date</u>	<u>Last value</u>	<u>Previous value</u>	<u>Units</u>	<u>% change</u>
CIV Vel 400 Hz	6/9/2011	0.242	---	in/s	---
CIV Vel 3KHz	6/9/2011	0.361	---	in/s	---
CMIA Vel 400 Hz	6/9/2011	0.251	---	in/s	---
CMIA Vel 3KHz	6/9/2011	0.314	---	in/s	---
CMIA Acc	6/9/2011	7.625	---	g	---
CMIA Gs Env	6/9/2011	14.051	---	gE	---
CMIA,TW	6/9/2011	13.666	---	g	---
CFIA Vel 400 Hz	6/9/2011	0.217	---	in/s	---
CFIA Vel 3KHz	6/9/2011	0.212	---	in/s	---
CFIA Acc	6/9/2011	1.898	---	g	---
CFIA Gs Env	6/9/2011	4.598	---	gE	---
COV Vel 400 Hz	6/9/2011	0.122	---	in/s	---
COV Vel 3KHz	6/9/2011	0.148	---	in/s	---
COV,TW	6/9/2011	5.201	---	g	---

#6 SEPARATOR

Last Measurement

<u>POINT name</u>	<u>Date</u>	<u>Last value</u>	<u>Previous value</u>	<u>Units</u>	<u>% change</u>
S003 VEL	6/9/2011	0.134	---	in/s	---
S103 VEL	6/9/2011	0.180	---	in/s	---
S203 VEL	6/9/2011	0.154	---	in/s	---
S303 VEL	6/9/2011	0.273	---	in/s	---
S403 VEL	6/9/2011	0.315	---	in/s	---
S503 VEL	6/9/2011	0.417	---	in/s	---
S006 VEL	6/9/2011	0.105	---	in/s	---
S106 VEL	6/9/2011	0.126	---	in/s	---
S206 VEL	6/9/2011	0.146	---	in/s	---
S306 VEL	6/9/2011	0.063	---	in/s	---
S406 VEL	6/9/2011	0.340	---	in/s	---
S506 VEL	6/9/2011	0.303	---	in/s	---
S009 VEL	6/9/2011	0.141	---	in/s	---
S109 VEL	6/9/2011	0.162	---	in/s	---
S209 VEL	6/9/2011	0.098	---	in/s	---
S309 VEL	6/9/2011	0.062	---	in/s	---
S409 VEL	6/9/2011	0.325	---	in/s	---
S509 VEL	6/9/2011	0.425	---	in/s	---
S012 VEL	6/9/2011	0.085	---	in/s	---
S112 VEL	6/9/2011	0.192	---	in/s	---
S212 VEL	6/9/2011	0.231	---	in/s	---
S312 VEL	6/9/2011	0.108	---	in/s	---
S412 VEL	6/9/2011	0.294	---	in/s	---
S512 VEL	6/9/2011	0.223	---	in/s	---

#4 Mtr RWFII-270

Last Measurement

<u>POINT name</u>	<u>Date</u>	<u>Last value</u>	<u>Previous value</u>	<u>Units</u>	<u>% change</u>
% OF FULL LOAD AMPS	6/9/2011	100.000	---	% LOAD	---
Runtime Hours	6/9/2011	13192.000	---	Any Units	---
MOH VEL 400Hz	6/9/2011	0.075	---	in/s	---
MOH VEL 3KHz	6/9/2011	0.200	---	in/s	---
MOH ACC	6/9/2011	6.128	---	g	---
MOH,TW	6/9/2011	12.990	---	g	---
MOV VEL 400Hz	6/9/2011	0.089	---	in/s	---
MOV VEL 3KHz	6/9/2011	0.215	---	in/s	---
MOV Env	6/9/2011	16.088	---	gE	---
MOA VEL 400Hz	6/9/2011	0.074	---	in/s	---
MOA VEL 3KHz	6/9/2011	0.102	---	in/s	---
MIH VEL 400Hz	6/9/2011	0.096	---	in/s	---
MIH VEL 3KHz	6/9/2011	0.276	---	in/s	---
MIH ACC	6/9/2011	8.772	---	g	---
MIH,TW	6/9/2011	16.160	---	g	---
MIV VEL 400Hz	6/9/2011	0.052	---	in/s	---
MIV VEL 3KHz	6/9/2011	0.178	---	in/s	---
MIV Env	6/9/2011	14.899	---	gE	---
MIA VEL 400Hz	6/9/2011	0.063	---	in/s	---
MIA VEL 3KHz	6/9/2011	0.121	---	in/s	---

#4 SGC RWFII-270

Last Measurement

<u>POINT name</u>	<u>Date</u>	<u>Last value</u>	<u>Previous value</u>	<u>Units</u>	<u>% change</u>
CIV Vel 400 Hz	6/9/2011	0.122	---	in/s	---
CIV Vel 3KHz	6/9/2011	0.263	---	in/s	---
CMIA Vel 400 Hz	6/9/2011	0.080	---	in/s	---
CMIA Vel 3KHz	6/9/2011	0.305	---	in/s	---
CMIA Acc	6/9/2011	10.006	---	g	---
CMIA Gs Env	6/9/2011	18.631	---	gE	---
CMIA,TW	6/9/2011	18.264	---	g	---
CFIA Vel 400 Hz	6/9/2011	0.116	---	in/s	---
CFIA Vel 3KHz	6/9/2011	0.175	---	in/s	---
CFIA Acc	6/9/2011	4.820	---	g	---
CFIA Gs Env	6/9/2011	15.066	---	gE	---
COV Vel 400 Hz	6/9/2011	0.177	---	in/s	---
COV Vel 3KHz	6/9/2011	0.372	---	in/s	---
COV,TW	6/9/2011	17.953	---	g	---

SEPARATOR
Last Measurement

<u>POINT name</u>	<u>Date</u>	<u>Last value</u>	<u>Previous value</u>	<u>Units</u>	<u>% change</u>
S003 VEL	6/9/2011	0.121	---	in/s	---
S103 VEL	6/9/2011	0.363	---	in/s	---
S203 VEL	6/9/2011	0.095	---	in/s	---
S303 VEL	6/9/2011	0.890	---	in/s	---
S403 VEL	6/9/2011	0.384	---	in/s	---
S503 VEL	6/9/2011	0.730	---	in/s	---
S006 VEL	6/9/2011	0.209	---	in/s	---
S106 VEL	6/9/2011	0.210	---	in/s	---
S206 VEL	6/9/2011	0.162	---	in/s	---
S306 VEL	6/9/2011	0.483	---	in/s	---
S406 VEL	6/9/2011	0.234	---	in/s	---
S506 VEL	6/9/2011	0.538	---	in/s	---
S009 VEL	6/9/2011	0.148	---	in/s	---
S109 VEL	6/9/2011	0.284	---	in/s	---
S209 VEL	6/9/2011	0.083	---	in/s	---
S309 VEL	6/9/2011	0.299	---	in/s	---
S409 VEL	6/9/2011	0.215	---	in/s	---
S509 VEL	6/9/2011	0.467	---	in/s	---
S012 VEL	6/9/2011	0.217	---	in/s	---
S112 VEL	6/9/2011	0.297	---	in/s	---
S212 VEL	6/9/2011	0.372	---	in/s	---
S312 VEL	6/9/2011	0.840	---	in/s	---
S412 VEL	6/9/2011	0.611	---	in/s	---
S512 VEL	6/9/2011	0.266	---	in/s	---

Overall Condition: Alert

Customer Name:
Location:
Make: Frick
Model: RWFII-270
Serial Number:
Customer ID number: #4
Runtime Hours: {Not Available}
Analyst:

Overall Machine History



Jun-13-11

Date

Fault(s) : The measurement in the C2 position indicates excessive non-synchronous energy.

Recommendation:

This machine should be monitored closely with another vibration analysis performed in 3-4 operating months to continue trending. Results from all diagnostic tests, including vibration analysis, oil analysis, and megger tests, should be used in conjunction with the machine's maintenance history and a qualified mechanic's recommendations to determine whether maintenance should be considered.

Vibration Analysis:

The vibration measurements are at alert levels. The vibration levels at the ball bearing defect frequencies indicate a possible problem with the compressor roller bearings.

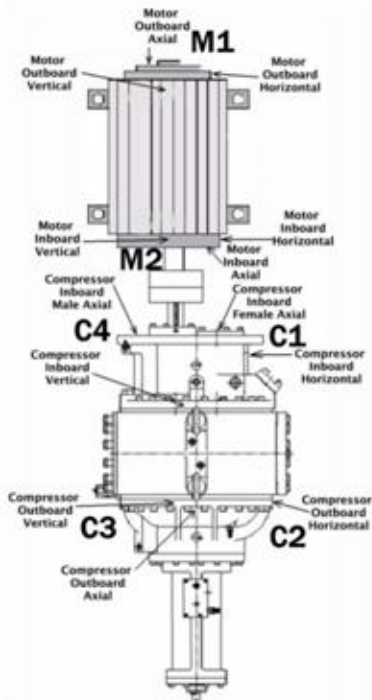

COV Ve1 3KHz

