

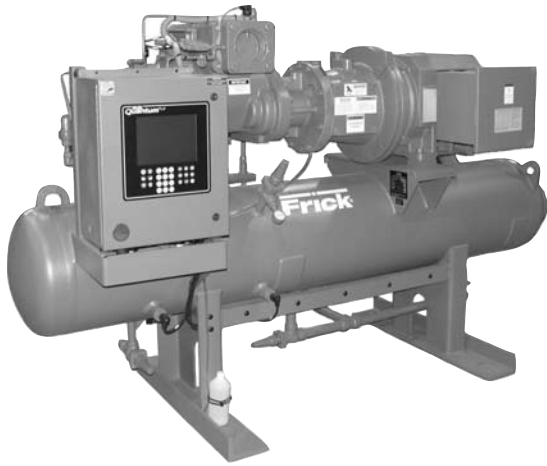

BY JOHNSON CONTROLS



RXF Rotary Screw Compressor Units are engineered and manufactured to meet the exacting requirements of the industrial refrigeration market. All components have been designed and arranged to assure reliability, accessibility, and ease of service. Standard units are designed for high-stage or booster duty with ammonia or halocarbon refrigerants and are shipped completely assembled.

COMPRESSOR: The Frick® manufactured RXF compressor incorporates the latest technology to offer the most reliable and energy efficient unit currently available. The ASTM A-48, class 40 gray iron compressor casings are designed and tested in accordance with the requirements of ASHRAE 15 safety code (362 psia maximum working pressure). The rotors are machined to the latest SRM asymmetric profile. This profile, in combination with an integral gear drive to increase rotor tip speed, brings unprecedented efficiency to screw compressors in this size range. The compressor incorporates a complete antifriction bearing design for reduced power consumption, improved efficiency, and reduced maintenance. The RXF compressor unit incorporates a NEMA “C” face or “D” flange motor into a close-coupled mounting arrangement. Compressor/motor assemblies require NO coupling alignment.

VOLUMIZER® II VARIABLE VOLUME RATIO CONTROL: The RXF compressor incorporates a simple mechanism which adjusts the compressor volume ratio during operation to the most efficient of three possible volume ratios, depending on system requirements. This minimizes the power penalty associated with over or undercompression and reduces excess bearing loading caused by running a machine at a less efficient Vi.

MOTOR: Factory mounted, **premium efficient, low noise motors** are standard. (NEMA “C” flange design up to 150 HP (Standard ODP) or NEMA “D” flange for larger motors) Motors are provided with class B insulation and 1.15 service factor. Standard 60 hertz voltages are 230/460 for 50–250 HP, or 460 for 300–400 HP. Standard 50 Hertz voltages are 190/380 for 40–200 HP, or 380 for 250–350 HP.

CAPACITY CONTROL: The compressor incorporates a slide valve for capacity control, allowing infinite capacity adjustment from 100% to 25% of full load.

Form E70-410A SPC (NOV 2007)

SPECIFICATIONS

File: EQUIPMENT MANUAL - Section 70
Replaces: NOTHING (New Information)
Dist: 1, 1a, 1b, 1c, 4, 4b, 4c

RXF

ROTARY SCREW COMPRESSOR UNITS Models 58 through 101

LUBRICATION SYSTEM: The RXF compressor is designed specifically for operation without an oil pump for high-stage service. All oil required for main oil injection and lubrication, is provided by positive gas differential pressure, and passes through our new Frick® SuperFilter™II, which cleans oil cleaner than new. SuperFilter™II captures 99% of particles 5 microns and larger and has twice the dirt holding capacity of the original SuperFilter™ for maximum bearing life.

OIL SEPARATOR/RESERVOIR: The oil separator is a horizontal, three-stage design with integral sump. It is designed and constructed in accordance with ASME Section VIII, Div. 1 for a maximum design working pressure of 300 psig. Replaceable coalescent separator elements are provided for final gas/oil separation of particles down to less than one micron.

OIL COOLING: Cooling the compressor oil may be achieved by either EZ-Cool™ liquid-refrigerant-injection oil cooling, water-cooled oil cooling, or thermosyphon oil cooling. Water cooled and thermosyphon oil-cooled systems are supplied with plate-type heat exchangers mounted on the unit. They are also equipped with an oil temperature control valve.

QUANTUM™ LX CONTROL CENTER: The Quantum™LX control panel is factory mounted, NEMA 4, UL® listed, and completely wired with all the required safety and operating devices. A 10.4" Active Color VGA Graphics Display offers a high contrast, crisp clear display of compressor information and status. Additional Input/Output can be easily installed in the field. This feature provides flexibility for future engine room upgrades and changes. Ethernet communications along with three field-selectable serial communication ports allow you to choose from a combination of RS-422, RS-485, or RS-232 port configurations for external communications. Included in the microprocessor are time-proportioning capacity control, first-out annunciation, prealarms, volumizer control, real-time clock control, access code protection, lead-lag sequencing, alternate suction pressure operation, trending, and more. The operating conditions at the time of the compressor's last fifty alarms or shutdowns are stored in memory, providing the ultimate in service and troubleshooting convenience.

VALVES: The unit's discharge has a mounted combination stop/check valve with a serviceable check valve assembly. The suction has an integral suction strainer and mounted check valve and a separately shipped stop valve.

OPTIONAL FEATURES: Starter Packages, Additional Oil Charge, Oversized Suction Stop Valve, Economizer Kit, Shipped Loose DX Economizer, Power Regulating Control Transformer, and Demand Oil Pumps.

STANDARD DESIGN DATA (with metric equivalents)

RFX MODEL NO.	MOTOR SPEED RPM	COMPRESSOR DISPLACEMENT		RATINGS R-717 (1)				RATINGS R-22 (2)				ESTIMATED SHIPPING WEIGHT WITH MOTOR		ESTIMATED OPERATING WEIGHT WITH MOTOR	
				CAPACITY		POWER		CAPACITY		POWER					
				CFM	M3/HR	TR	kw	BHP	kw	TR	kw				
58	3550	341	579	120.9	425.2	143.3	106.9	110.4	388.3	153.1	114.2	6941	3148	8236	3735
68	3550	403	685	142.7	501.9	169.3	126.2	130.4	458.6	180.9	134.9	6941	3148	8236	3735
85	3550	499	848	176.8	621.8	209.6	156.3	161.5	567.9	224.0	167.0	7566	3431	8861	4018
101	3550	596	1013	211.4	743.5	250.7	186.9	193.1	679.2	267.9	199.7	7566	3431	8861	4018

1. R-717: +20°F (-6.7°C) suction and 95°F (35°C) condensing with 10°F (5.5°C) liquid subcooling and 10°F (5.5°C) suction superheat.
2. R-22: +20°F (-6.7°C) suction and 105°F (40.6°C) condensing with 10°F (5.5°C) liquid subcooling and 10°F (5.5°C) suction superheat.

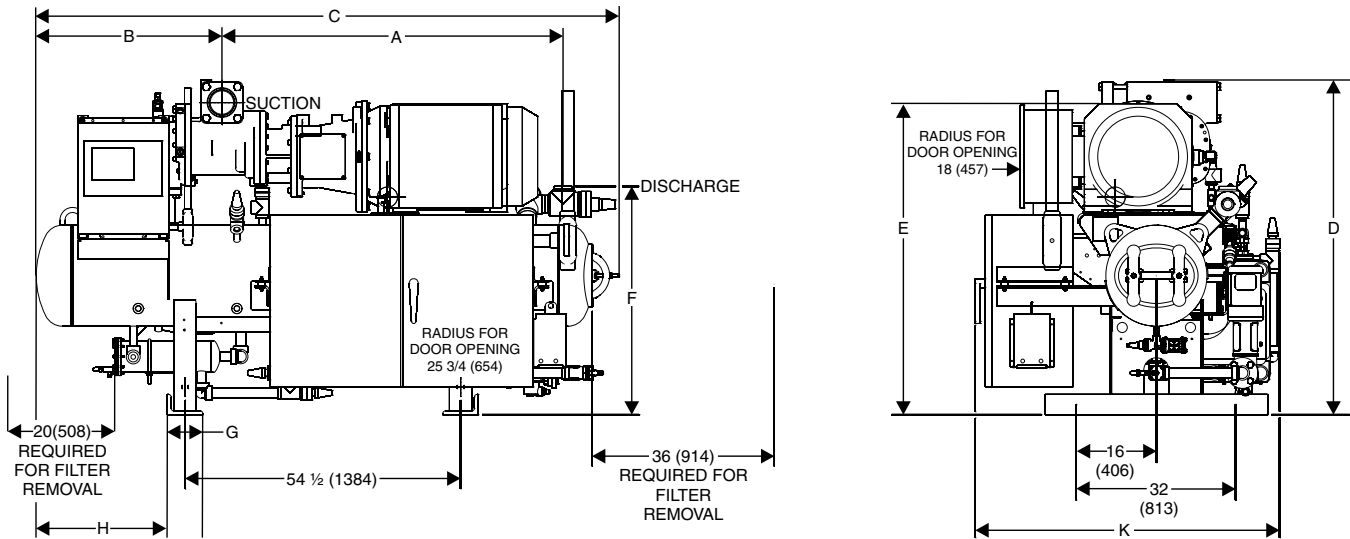

NOTE: Drawing for reference only! Use certified drawings for erection.

MODEL NO.	CONNECTION				DIMENSIONS									
	SUCTION		DISCHARGE		A		B		C		D		E	
	In.	mm	In.	mm	In.	mm	In.	mm	In.	mm	In.	mm	In.	mm
RXF 58	5	127.00	3	76.20	67 1/2	1714.50	36 3/4	933.45	115 5/16	2928.94	66 1/4	1682.75	61 3/4	1568.45
RXF 68	5	127.00	3	76.20	67 1/2	1714.50	36 3/4	933.45	115 5/16	2928.94	66 1/4	1682.75	61 3/4	1568.45
RXF 85	5	127.00	4	101.60	68 5/8	1743.08	36 3/4	933.45	117 1/16	2973.39	70 3/4	1797.05	66 1/4	1682.75
RXF 101	5	127.00	4	101.60	68 5/8	1743.08	36 3/4	933.45	117 1/16	2973.39	70 3/4	1797.05	66 1/4	1682.75

MODEL NO.	DIMENSIONS							
	F		G		H		K	
	In.	mm	In.	mm	In.	mm	In.	mm
RXF 58	45 3/16	1147.76	7	177.80	29 7/16	747.71	60 3/16	1528.76
RXF 68	45 3/16	1147.76	7	177.80	29 7/16	747.71	60 3/16	1528.76
RXF 85	49 1/2	1257.30	7	177.80	28 15/16	735.01	59 3/4	1517.65
RXF 101	49 1/2	1257.30	7	177.80	28 15/16	735.01	59 3/4	1517.65

NOTE: The suction stop valve is shipped separately for field installation. Make allowances for piping.

1. Allow 36 in./915 mm for coalescer filter and 20 in./508 mm for oil filter accessibility.
2. Maximum width applies to WCO or TSOC package with Oil Temperature Control Valve.