

RXF

ROTARY SCREW COMPRESSOR UNITS

MODELS 12 - 101

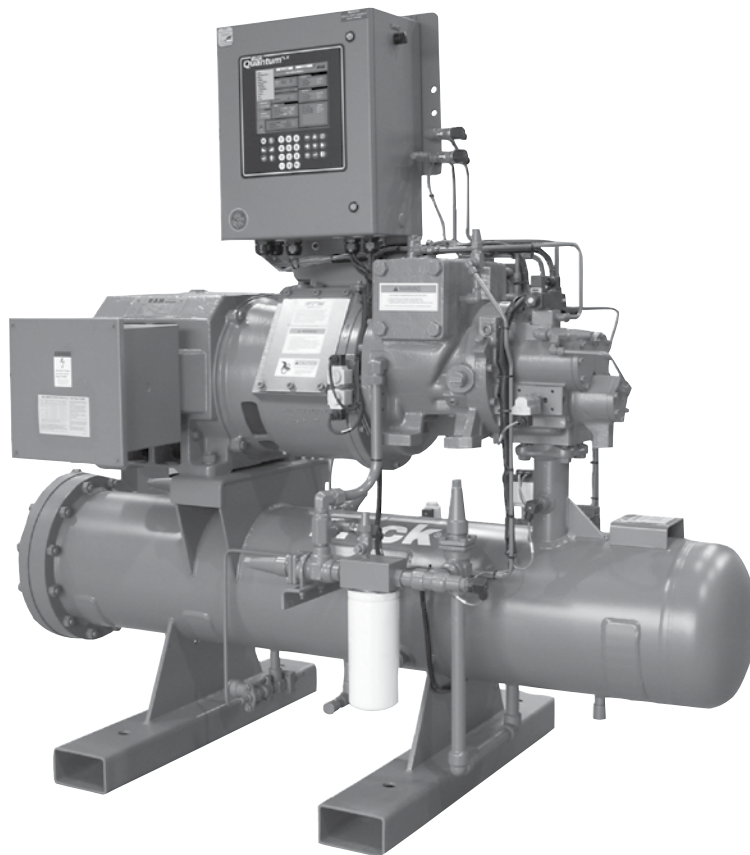

THIS MANUAL CONTAINS RIGGING, ASSEMBLY, START-UP, AND MAINTENANCE INSTRUCTIONS. READ THOROUGHLY BEFORE BEGINNING INSTALLATION. FAILURE TO FOLLOW THESE INSTRUCTIONS COULD RESULT IN DAMAGE OR IMPROPER OPERATION OF THE UNIT.

TABLE OF CONTENTS

PREFACE	3
DESIGN LIMITATIONS	3
JOB INSPECTION.....	3
TRANSIT DAMAGE CLAIMS	3
UNIT IDENTIFICATION	3
COMPRESSOR IDENTIFICATION	4

INSTALLATION

FOUNDATION	5
HANDLING and MOVING.....	5
SKID REMOVAL.....	6
COMPRESSOR/MOTOR COUPLINGS	6
CH COUPLING.....	6
HOLDING CHARGE and STORAGE	6
COMPRESSOR OIL.....	7
OIL CHARGE	7
OIL HEATER.....	7
OIL FILTER(S).....	7
THERMOSYPHON OIL COOLING	7
WATER-COOLED OIL COOLING	8
LIQUID INJECTION OIL COOLING	9
DUAL DIP TUBE METHOD	9
ECONOMIZER - HIGH STAGE (OPTIONAL).....	10
ELECTRICAL	11
MOTOR STARTER PACKAGE	11
MINIMUM BURDEN RATINGS.....	12
CONTROL POWER REGULATOR.....	12

OPERATION

OPERATION and START-UP INSTRUCTIONS	13
RXF COMPRESSOR	13
COMPRESSOR LUBRICATION SYSTEM	13
NO PUMP OIL SYSTEM	13
COLD-START SYSTEM.....	13
DEMAND PUMP OIL SYSTEM	14
COMPRESSOR OIL SEPARATION SYSTEM.....	14
COMPRESSOR HYDRAULIC SYSTEM	14
CAPACITY CONTROL.....	14
VOLUMIZER® II Vi CONTROL.....	15
SLIDE VALVE CALIBRATION	15
COMPRESSOR OIL COOLING SYSTEMS	16
SINGLE-PORT LIQUID INJECTION.....	16
DUAL-PORT LIQUID INJECTION	16
QUANTUM™LX EZ-COOL™ LIQUID INJECTION	
ADJUSTMENT PROCEDURE	16
DANFOSS LIQUID INJECTION VALVE.....	18
THERMOSYPHON OIL COOLING.....	21
INITIAL START-UP PROCEDURE	21
NORMAL START-UP PROCEDURE	21
RESTARTING COMPRESSOR.....	21

MAINTENANCE

NORMAL MAINTENANCE OPERATIONS.....	22
GENERAL MAINTENANCE	22
COMPRESSOR SHUTDOWN and START-UP.....	22
COMPRESSOR/MOTOR SERVICING.....	22
GENERAL INSTRUCTIONS FOR REPLACING	
COMPRESSOR UNIT COMPONENTS	23
OIL FILTER, SPIN-ON (RXF 12 – 50)	23
OIL FILTER, SINGLE ELEMENT (58 – 101)	23
COALESCER OIL RETURN STRAINER	24
LIQUID INJECTION STRAINER	24
OIL PUMP STRAINER (Optional)	24
SUCTION CHECK VALVE BYPASS	24
COALESCER FILTER ELEMENT	25
CHANGING OIL	25
SUCTION STRAINER CLEANING PROCEDURE	25
DEMAND PUMP DISASSEMBLY.....	26
DEMAND PUMP ASSEMBLY.....	27
TROUBLESHOOTING THE DEMAND PUMP.....	28
RECOMMENDED MAINTENANCE PROGRAM	29
VIBRATION ANALYSIS	29
OIL QUALITY and ANALYSIS	29
MAINTENANCE SCHEDULE.....	30
MOTOR BEARINGS.....	31
OPERATING LOG	31
TROUBLESHOOTING GUIDE	31
ABNORMAL OPERATION	
ANALYSIS and CORRECTION.....	31
PRESSURE TRANSDUCERS - TESTING	32
PRESSURE TRANSDUCERS REPLACEMENT.....	33
SLIDE VALVE TRANSMITTER	
REPLACEMENT - SLIDE STOP	33
TEMPERATURE SENSOR REPLACEMENT	33
OIL LEVEL TRANSMITTER REPLACEMENT	34
TEMPERATURE and/or PRESSURE ADJUSTMENT.....	34
BARE COMPRESSOR MOUNTING	34
TROUBLESHOOTING THE COMPRESSOR.....	35
OIL SEPARATOR.....	35
LIQUID INJECTION OIL COOLING SYSTEM.....	36
HYDRAULIC SYSTEM.....	36
COMPRESSOR PORT LOCATIONS - RXF 12 - 19.....	37
P & I DIAGRAMS.....	39
PROPER INSTALLATION OF ELECTRONIC EQUIPMENT	
IN AN INDUSTRIAL ENVIRONMENT	48
FORMS.....	53
INDEX.....	60

PREFACE

This manual has been prepared to acquaint the owner and service person with the **INSTALLATION, OPERATION, and MAINTENANCE** procedures as recommended by Frick for **RXF** Rotary Screw Compressor Units.

It is most important that these units be properly applied to an adequately controlled refrigeration system. Your authorized Frick representative should be consulted for expert guidance in this determination.

Proper performance and continued satisfaction with these units is dependent upon:

**CORRECT INSTALLATION
PROPER OPERATION
REGULAR, SYSTEMATIC PLANNED MAINTENANCE**

To ensure correct installation and application, the equipment must be properly selected and connected to a properly designed and installed system. The Engineering plans, piping layouts, etc. must be detailed in accordance with the best practices and local codes, such as those outlined in ASHRAE literature.

A refrigeration compressor is a **VAPOR PUMP**. To be certain that it is not being subjected to liquid refrigerant carryover, it is necessary that refrigerant controls are carefully selected and in good operating condition; the piping is properly sized and traps, if necessary, are correctly arranged; the suction line has an accumulator or slugging protection; that load surges are known and provisions made for control; operating cycles and defrosting periods are reasonable; oil return is controlled; and that high side condenser units control head pressures and temperatures are within system and compressor design limits.

It is recommended that the entering vapor temperature to the compressor be superheated to 10°F above the refrigerant saturation temperature to ensure that all refrigerant at the compressor suction is in the vapor state.

DESIGN LIMITATIONS

The compressor units are designed for operation within the pressure and temperature limits as shown in Frick Publication E70-400 SED.

JOB INSPECTION

Immediately upon arrival examine all crates, boxes, and exposed compressor and component surfaces for damage. Unpack all items and check against shipping lists for any possible shortage. Examine all items for damage in transit.

SAFETY PRECAUTION DEFINITIONS



Indicates an imminently hazardous situation which, if not avoided, will result in death or serious injury.



Indicates a potentially hazardous situation or practice which, if not avoided, will result in death or serious injury.



Indicates a potentially hazardous situation or practice which, if not avoided, will result in damage to equipment and/or minor injury.

NOTE:

Indicates an operating procedure, practice, etc., or portion thereof which is essential to highlight.

TRANSIT DAMAGE CLAIMS

All claims must be made by consignee. This is an ICC requirement. Request immediate inspection by the agent of the carrier and be sure the proper claim forms are executed.

Contact Johnson Controls-Frick, Sales Administration Department, in Waynesboro, PA to report damage or short-age claims.

UNIT IDENTIFICATION

Each compressor unit has 2 identification data plates. The unit data plate containing unit model, serial number and Frick sales order number is mounted on the control panel support bracket. The compressor data plate containing compressor model and serial number is mounted on the compressor body.

NOTE: When inquiring about the compressor or unit, or ordering repair parts, provide the MODEL, SERIAL, and FRICK SALES ORDER NUMBERS from these data plates.

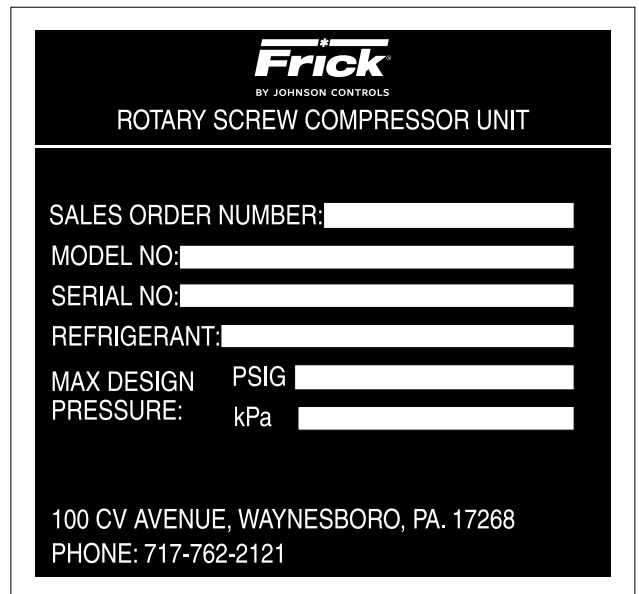

UNIT DATA PLATE



BY JOHNSON CONTROLS

ROTARY SCREW COMPRESSOR

MODEL NO.

SERIAL NO.

MAX ALLOWABLE PRESSURE - PSIG	MAX DRIVER SPEED - RPM
<input style="width: 80%; height: 15px;" type="text"/>	<input style="width: 80%; height: 15px;" type="text"/>

WAYNESBORO, PA 17268

COMPRESSOR DATA PLATE

Rotary screw compressor serial numbers are defined by the following information:

EXAMPLE: 10240A90000015Z

PLANT	DECADE	MONTH	YEAR	GLOBAL SEQ NO.	ADDITIONAL REMARKS
1024	0	A	9	0000015	Z

Month: A = JAN, B = FEB, C = MAR, D = APR, E = MAY, F = JUN, G = JUL, H = AUG, K = SEP, L = OCT, M = NOV, N = DEC.

Additional Remarks: R = Remanufactured; Z = Deviation from Standard Configuration.

GEOMETRICAL SWEEP VOLUME TABLE

Compressor Model	Rotor Diameter mm	Rotor L/D	Max Speed RPM	Geometrical Swept Volume Drive Shaft End Ft ³ / Rev	M ³ /Rev	CFM	M ³ /H
					3550 RPM	2950 RPM	
XJS/XJF 95M	95	1.4	5,772	0.02513	0.000711	89	126
XJS/XJF 95L	95	1.4	4,661	0.03112	0.000881	110	156
XJS/XJF 95S	95	1.4	3,600	0.04086	0.001156	145	205
XJS/XJF 120M	120	1.4	5,772	0.05065	0.001433	180	254
XJS/XJF 120L	120	1.4	4,661	0.06272	0.001775	223	314
XJS/XJF 120S	120	1.4	3,600	0.08234	0.002330	292	412
XJF 151A	151	1.6	6,297	0.09623	0.002723	342	482
XJF 151M	151	1.6	5,332	0.11366	0.003217	403	569
XJF 151L	151	1.6	4,306	0.14075	0.003983	500	705
XJF 151N	151	1.6	3,600	0.16833	0.004764	598	843

Installation

FOUNDATION

NOTE: Allow space for servicing both ends of the unit. A minimum of 24 inches is recommended.

The first requirement of the compressor foundation is that it must be able to support the weight of the compressor package including coolers, oil, and refrigerant charge. Screw compressors are capable of converting large quantities of shaft power into gas compression in a relatively small space and a mass is required to effectively dampen these relatively high frequency vibrations.

Firmly anchoring the compressor package to a suitable foundation by proper application of grout and elimination of piping stress imposed on the compressor is the best insurance for a trouble free installation. Use only the certified general arrangement drawings from Frick® to determine the mounting foot locations and to allow for recommended clearances around the unit for ease of operation and servicing. Foundations must be in compliance with local building codes and materials should be of industrial quality.

The floor shall be a minimum of 6 inches of reinforced concrete and housekeeping pads are recommended. Anchor bolts are required to firmly tie the unit to the floor. Once the unit is rigged into place (See HANDLING and MOVING), the feet must then be shimmed in order to level the unit. The shims should be placed to position the feet roughly one inch above the housekeeping pad to allow room for grouting. An expansion-type epoxy grout must be worked under all areas of the base with no voids and be allowed to settle with a slight outward slope so oil and water can run off of the base.

When installing on a steel base, the following guidelines should be implemented to properly design the system base:

1. Use I-beams in the skid where the screw compressor will be attached to the system base. They shall run parallel to the package feet and support the feet for their full length.
2. The compressor unit feet shall be continuously welded to the system base at all points of contact, or bolted.
3. The compressor unit shall not be mounted on vibration isolators in order to hold down package vibration levels.
4. The customer's foundation for the system base shall fully support the system base under all areas, but most certainly under the I-beams that support the compressor package.

When installing on the upper floors of buildings, extra precautions should be taken to prevent normal package vibration from being transferred to the building structure. It may be necessary to use rubber or spring isolators, or a combination of both, to prevent the transmission of compressor vibration directly to the structure. However, this may increase package vibration levels because the compressor is not in contact with any damping mass. The mounting and support of suction and discharge lines is also very important. Rubber or spring pipe supports may be required to avoid exciting the building structure at any pipe supports close to the compressor package. It is best to employ a vibration expert in the design of a proper mounting arrangement.

In any screw compressor installation, suction and discharge lines shall be supported in pipe hangers (preferably within 2 feet of vertical pipe run) so that the lines won't move if disconnected from the compressor. See table for Allowable Flange Loads.

NOZ. SIZE NPS	ALLOWABLE FLANGE LOADS					
	MOMENTS (ft-lbf)			LOAD (lbf)		
	AXIAL	VERT.	LAT.	AXIAL	VERT.	LAT.
	M _R	M _C	M _L	P	V _C	V _L
1	25	25	25	50	50	50
1.25	25	25	25	50	50	50
1.5	50	40	40	100	75	75
2	100	70	70	150	125	125
3	250	175	175	225	250	250
4	400	200	200	300	400	400
5	425	400	400	400	450	450
6	1,000	750	750	650	650	650
8	1,500	1,000	1,000	1,500	900	900
10	1,500	1,200	1,200	1,500	1,200	1,200
12	1,500	1,500	1,500	1,500	1,500	1,500
14	2,000	1,800	1,800	1,700	2,000	2,000

Proper foundations and proper installation methods are vital; and even then, sound attenuation or noise curtains may be required to reduce noise to desired levels.

For more detailed information on Screw Compressor Foundations, please request Frick publication S70-210 IB.

HANDLING and MOVING

RXF 12–50 units can be moved with a forklift or with rigging and a crane. The recommended method is to insert lengths of 2" pipe through the base tubing (see Figure 1 below).

CAUTION Spreader bars should be used on both the length and width of the package to prevent bending oil lines and damage to the package. CAUTION must also be used in locating the lifting ring. Appropriate adjustment in the lifting point should be made to compensate for motor weight. Adjustment of the lifting point must also be made for any additions to the standard package such as an external oil cooler, etc., as the center of balance will be effected.

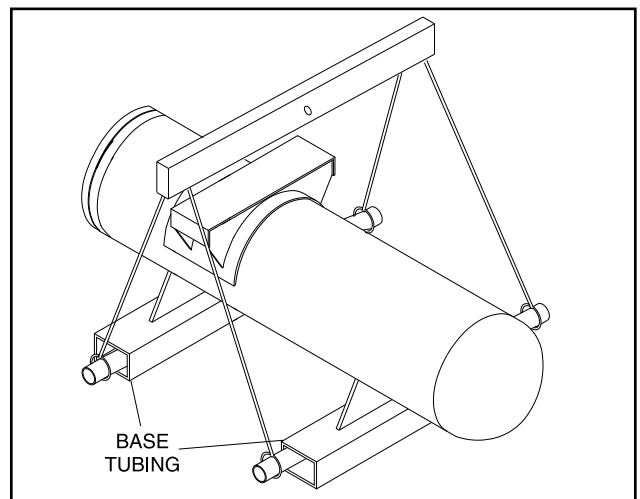

Figure 1 - RXF 12 – 50

The unit can be moved with a forklift by forking through the base tubing. **NEVER MOVE THE UNIT BY PUSHING OR FORKING AGAINST THE SEPARATOR SHELL OR ITS MOUNTING SUPPORTS.**

RXF 58 – 101 units can be moved with rigging, using a crane or forklift by hooking into three lifting points on the oil separator. See Figure 2.

CAUTION Spreader bars may be required on both the length and width of the package to prevent bending oil lines and damage to the package. CAUTION must also be used in locating the lifting ring. Appropriate adjustment in the lifting point should be made to compensate for motor weight. Adjustment of the lifting point must also be made for any additions to the standard package such as an external oil cooler, etc., as the center of balance will be affected.

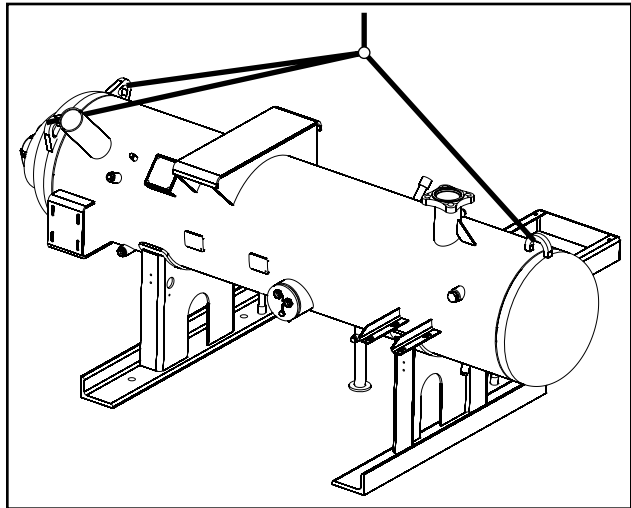

Figure 2 - RXF 58 – 101

The unit can be moved with a forklift by forking **under the wooden skid (if provided)**, or it can be skidded into place with pinch bars by pushing against the skid. **NEVER MOVE THE UNIT BY PUSHING OR FORKING AGAINST THE SEPARATOR SHELL OR ITS MOUNTING SUPPORTS.**

SKID REMOVAL

CAUTION This screw compressor package may be top-heavy. Use caution to prevent unit from turning over.

If the unit is rigged into place, the wooden skid can be removed by taking off the nuts and bolts that are fastening the unit mounting supports to the skid before lowering the unit onto the mounting surface.

If the unit is skidded into place, remove the cross members from the skid and remove the nuts anchoring the unit to the skid. Using a 10-ton jack under the separator, raise the unit at the compressor end until it clears the two mounting bolts. Spread the skid to clear the unit mounting support, then lower the unit to the surface. Repeat procedure on opposite end.

COMPRESSOR/MOTOR COUPLINGS

RXF units are arranged for direct motor drive and include a flexible drive coupling to connect the compressor to the motor.

CH COUPLING

The T. B. Woods Elastomeric Type CH Coupling is used in most applications. This coupling consists of two drive hubs and a gear-type Hytrel, EDPM, or neoprene drive spacer. The split hub is clamped to the shaft by tightening the clamp screws. Torque is transmitted from the motor through the elastomeric gear which floats freely between the hubs. Because of the use of the motor/compressor adapter housing on the RXF, no field alignment is necessary.

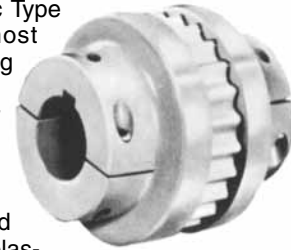

WARNING It is mandatory that the coupling center be removed and the direction of motor rotation be confirmed before running the compressor. Proper rotation of the compressor shaft is clockwise looking at the end of the compressor shaft. Failure to follow this step could result in backward compressor rotation which can cause compressor failure or explosion of the suction housing.

1. Inspect the shaft of the motor and compressor to ensure that no nicks, grease, or foreign matter is present.
2. Inspect the bores in the coupling hubs to make sure that they are free of burrs, dirt, and grit.
3. Check that the keys fit the hubs and shafts properly.
4. Slide one hub onto each shaft as far as possible. It may be necessary to use a screwdriver as a wedge in the slot to open the bore before the hubs will slide on the shafts.
5. Hold the elastomeric gear between the hubs and slide both hubs onto the gear to fully engage the mating teeth. Center the gear and hub assembly so there is equal engagement on both shafts. Adjust the space between hubs as specified in the CH Coupling Data Table below. **NOTE: The center section will be a little loose between the hubs. This allows for growth during operation.**
6. Torque the clamping bolts in both hubs to the torque value given in the CH Data Table. **DO NOT USE ANY LUBRICANT ON THESE BOLTS.**

HOLDING CHARGE and STORAGE

Each compressor unit is pressure and leak tested at the Johnson Controls-Frick factory and then thoroughly evacuated and charged with dry nitrogen to ensure the integrity of the unit during shipping and short term storage prior to installation.

CH COUPLING DATA TABLE

CH Series	Coupling Hub															
	Between Shaft Spacing				Shaft Engagement				Face Spacing		Clamp Bolt			Keyway		Size UNC
	Min.		Max.		Min.		Max.				Torque (Dry)		Size	Setscrew Torque		
Size	In.	mm	In.	mm	In.	mm	In.	mm	In.	mm	Ft-Lb	Nm	Size	Ft-Lb	Nm	
6	2	50.8	2 3/4	69.9	1	25.4	1 15/16	49.2	7/8	22.2	15	20.3	1/4-20 UNC	13	17.6	5/16-18
7	2 5/16	58.7	3 7/16	87.3	1	25.4	2 3/16	55.6	1 1/16	27.0	30	40.7	5/16-24 UNF	13	17.6	5/16-18
8	2 9/16	65.1	4	101.6	1 1/16	27.0	2 1/2	63.5	1 1/8	28.6	55	74.6	3/8-24 UNF	13	17.6	5/16-18
9	3 1/16	77.8	4 5/8	117.5	1 7/16	36.5	3	76.2	1 7/16	36.5	55	74.6	3/8-24 UNF	13	17.6	5/16-18
10	3 3/16	90.5	5 1/4	133.4	1 11/16	42.9	3 1/2	88.9	1 11/16	42.9	130	176.3	1/2-20 UNF	13	17.6	5/16-18

NOTE: Care must be taken when entering the unit to ensure that the nitrogen charge is safely released.

WARNING Holding charge shipping gauges on separator and external oil cooler are rated for 30 PSIG and are for checking the shipping charge only. They must be removed before pressure testing the system and before charging the system with refrigerant. Failure to remove these gauges may result in catastrophic failure of the gauge and uncontrolled release of refrigerant resulting in serious injury or death.

All units must be kept in a clean, dry location to prevent corrosion damage. Reasonable consideration must be given to proper care for the solid-state components of the microprocessor.

Units which will be stored for more than two months must have the nitrogen charge checked periodically. Contact Frick for long term storage procedure.

COMPRESSOR OIL

WARNING DO NOT MIX OILS of different brands, manufacturers, or types. Mixing of oils may cause excessive oil foaming, nuisance oil level cutouts, oil pressure loss, gas or oil leakage and catastrophic compressor failure.

NOTE: The oil charge shipped with the unit is the best suited lubricant for the conditions specified at the time of purchase. If there is any doubt due to the refrigerant, operating pressures, or temperatures; refer to Frick Pub. 160-802 SPC for guidance.

OIL CHARGE

The normal charging level is midway in the top sight glass located midway along the oil separator shell. Normal operating level is between the top sight glass and bottom sight glass. Oil charge quantities are as follows:

RXF MODEL	BASIC CHARGE (gallon)	ADDITIONAL FOR OIL COOLER (gallon)
12 – 19	10	1
24 – 50	11	1
58, 68	25	3½
85, 101	36	3½

Add oil by attaching the end of a suitable pressure type hose to the oil drain valve, located under the oil separator. Using a pressure-type pump and the recommended Frick® oil, open the drain valve and pump oil into the separator. **NOTE: Evacuation of the oil separator will assist the flow of oil into the unit. Also, fill slowly because oil will fill up in the separator faster than it shows in the sight glass.**

Oil distillers and similar equipment which trap oil must be filled prior to unit operation to normal design outlet levels. The same pump used to charge the unit may be used for filling these auxiliary oil reservoirs.

The sight glass located near the bottom of the separator shell at the discharge end should remain empty when the unit is in operation. The presence of oil in this end of the vessel during operation indicates liquid carryover or malfunction of the oil return.

OIL HEATER

Standard units are equipped with 500 watt oil heaters, which provide sufficient heat to maintain the oil temperature for most indoor applications during shutdown cycles and to permit safe start-up. RXF 12–50 use one heater while models 58–101 use two. Should additional heating capacity be required because of an unusual environmental condition, contact Frick. The heater is energized only when the unit is not in operation.

WARNING Do not energize the heater when there is no oil in the unit, otherwise the heater will burn out. The oil heater will be energized whenever 120 volt control power is applied to the unit and the compressor is not running, unless the 16 amp circuit breaker in micro enclosure is turned off (or 15 amp fuse (1FU) in the Plus panel is removed).

OIL FILTER(S)

CAUTION Use of filter elements other than Frick may cause warranty claim to be denied.

The oil filter(s) and coalescer filter element(s) shipped with the unit are best suited to ensure proper filtration and operation of the system.

THERMOSYPHON OIL COOLING

EQUIPMENT: The basic equipment required for a thermosyphon system consists of:

1. A source of liquid refrigerant at condensing pressure and temperature located in close proximity to the unit to minimize piping pressure drop.

The liquid level in the refrigerant source must be 6 to 8 feet above the center of the oil cooler.

2. A shell and tube or plate-type oil cooler with a minimum 300 psi design working pressure on both the oil and refrigerant sides.

Due to the many variations in refrigeration system design and physical layout, several systems for assuring the above two criteria are possible.

INSTALLATION: The plate-type thermosyphon oil cooler with oil side piping and a thermostatically controlled mixing valve are factory mounted and piped. See Figure 3.

1. Thermosyphon oil cooler is supplied with oil side piped to the compressor unit and socket weld ends supplied on the refrigerant side.

2. A refrigerant-side safety valve is required when refrigerant isolation valves are installed between the cooler and thermosyphon receiver. If no valves are used between the cooler and thermosyphon receiver, the safety valve on the thermosyphon receiver must be sized to handle the volume of both vessels. Then, the safety valve on the cooler vent (liquid refrigerant side) can be eliminated.

3. System receiver must be mounted below thermosyphon receiver level in this arrangement.

4. The refrigerant source, thermosyphon or system receiver, should be in close proximity to the unit to minimize piping pressure drop.

5. The liquid level in the refrigerant source must not be less than 6 feet above the center of the oil cooler.

6. Installation of an angle valve in the piping before the thermosyphon oil cooler is recommended to balance the thermosyphon system. We also recommend the installation of sight glasses at the TSOC inlet and outlet to aid in troubleshooting. The factory-mounted plate-type thermosyphon oil cooler requires a refrigerant-side drain valve to be provided and installed by the customer.

The component and piping arrangement shown in Figure 3 is intended only to illustrate the operating principles of thermosyphon oil cooling. Other component layouts may be better suited to a specific installation. Refer to publication 070-900E for additional information on Thermosyphon Oil Cooling.

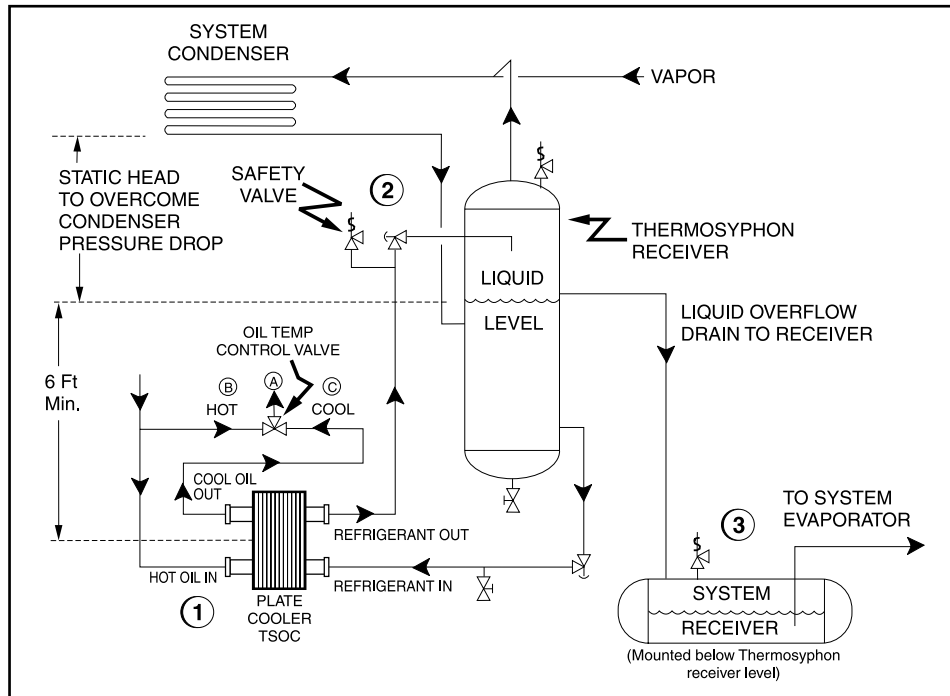

Figure 3

WATER-COOLED OIL COOLING

The plate-type water-cooled oil cooler is mounted on the unit complete with all oil piping. The customer must supply adequate water to the oil cooler.

A closed-loop system for the waterside of the oil cooler is recommended. Careful attention to water treatment is essential to ensure adequate life of the cooler if cooling tower water is used. **It is imperative that the condition of cooling water and closed-loop fluids be analyzed regularly and as necessary and maintained at a pH of 7.4, but not less than 6.0 for proper heat exchanger life.** After initial start-up of the compressor package, the strainer at the inlet of the oil cooler should be cleaned several times in the first 24 hours of operation.

In some applications, the plate-type oil cooler may be subjected to severe water conditions, including high temperature and/or hard water conditions. This causes accelerated scaling rates which will penalize the performance of the heat exchanger. A chemical cleaning process will extend the life of the heat exchanger. It is important to establish regular cleaning schedules.

Cleaning: A 3% solution of Phosphoric or Oxalic Acid is recommended. Other cleaning solutions can be obtained from your local distributor, but they must be suitable for stainless steel. The oil cooler may be cleaned in place by back flushing with recommended solution for approximately 30 minutes. After back flushing, rinse the heat exchanger with fresh water to remove any remaining cleaning solution.

FIELDWELDING INSTRUCTIONS FORTSOC ANDWCOC:

The heat exchanger body is constructed in stainless steel, while the stub connections are carbon steel. The highly polished stub connections can give the appearance of stainless steel. The following are requirements for welding to the socket weld fittings on Plate heat exchangers:

1. Use a heat sink paste around the base of the connection. These are available from a number of suppliers of welding materials.



Heat-sink paste must be applied around the base of the connection prior to welding. See Figure 4.

2. Two-pass welding is required; stagger start/stop region; welding procedure in accordance with ASME Section 9.

3. If possible use gas protection, when welding, to avoid oxidation of the surface. As it is rarely possible to clean the root side of the weld by grinding or brushing to remove the root oxide, it is optimal to use root gas.

4. Welding should occur in two segments, from 6:00 to 12:00. The maximum intersegment temperature should be 350°F. Temperature should be verified with temperature indicating crayon or equivalent.

5. The fitting may be cooled with forced air to reduce the temperature of the fitting to 350°F or lower, prior to welding the second segment.

The maximum connection static forces and moments for Alfa Nova heat exchangers are listed in the following table. Keep these values in mind when designing your system. It is also recommended to minimize connection loads when designing piping systems. Also see Figure 5.

	Fx	Fy	Fz	Mx	My	Mz
	(lb _f)	(lb _f)	(lb _f)	(lb _f ft)	(lb _f ft)	(lb _f ft)
ANHP52	202	13	13	57	32	32
ANHP76	292	22	22	103	58	58



Figure 4 - Application of heat-sink paste before welding

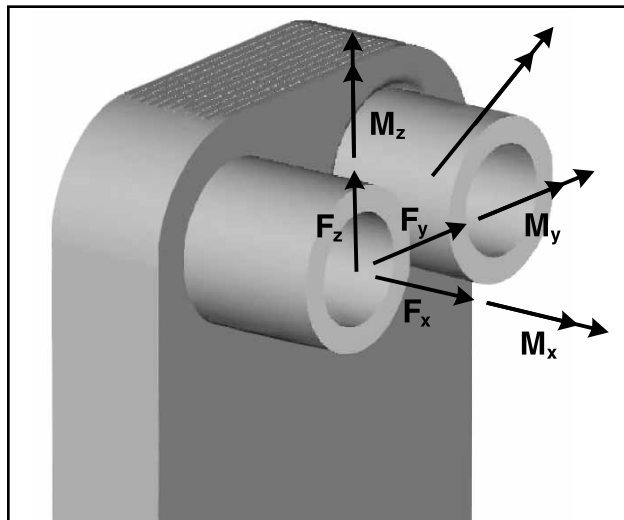

Figure 5 - Maximum static forces and moments

LIQUID INJECTION OIL COOLING

The liquid injection system provided on the unit is self-contained but requires the connection of the liquid line sized as shown in the table.

Liquid line sizes and the additional receiver volume (quantity of refrigerant required for 5 minutes of liquid injection oil cooling) are given in the following table:

REFRIG	RXF MODEL	LIQ. LINE SIZE*		FLOW RATE (lb) 5 MIN	LIQUID VOLUME CU. FT.
		PIPE SCH 80	TUBING OD		
R-717 HIGH STAGE	12	1/2	—	10	0.3
	15	1/2	—	12.5	0.4
	19	1/2	—	15	0.4
	24	1/2	—	20	0.6
	30	1/2	—	25	0.7
	39	1/2	—	30	0.8
	50	3/4	—	40	1.1
	58	3/4	—	47	1.3
	68	3/4	—	55	1.6
	85	3/4	—	70	2.0
101	3/4	—	80	2.3	

REFRIG	RXF MODEL	LIQ. LINE SIZE*		FLOW RATE (lb) 5 MIN	LIQUID VOLUME CU. FT.
		PIPE SCH 80	TUBING OD		
R-507 HIGH STAGE	12	3/4	7/8	17	0.3
	15	3/4	7/8	20	0.3
	19	3/4	7/8	22	0.4
	24	3/4	7/8	31	0.5
	30	3/4	7/8	36	0.6
	39	3/4	7/8	42	0.7
	50	1 1/4	1 3/8	56	0.9
	58	1 1/4	1 3/8	68	1.1
	68	1 1/4	1 3/8	78	1.2
	85	1 1/4	1 3/8	97	1.5
101	1 1/4	1 3/8	120	1.9	
R-717 BOOSTER	12	1/2	—	2.0	0.1
	15	1/2	—	2.5	0.1
	19	1/2	—	3.5	0.1
	24	1/2	—	4.5	0.1
	30	1/2	—	5.5	0.2
	39	1/2	—	6.5	0.2
	50	1/2	—	8.5	0.3
	58	1/2	—	10	0.3
	68	1/2	—	12	0.3
	85	1/2	—	15	0.4
101	1/2	—	18	0.5	
R-507 BOOSTER	12	3/8	1/2	5.5	0.1
	15	3/8	1/2	6	0.1
	19	3/8	1/2	7	0.1
	24	3/8	1/2	10	0.2
	30	3/8	1/2	11	0.2
	39	3/8	1/2	13	0.2
	50	3/4	7/8	17	0.3
	58	3/4	7/8	23	0.4
	68	3/4	7/8	26.5	0.4
	85	3/4	7/8	33	0.5
101	3/4	7/8	40.5	0.6	

* 100 ft. liquid line. For longer runs, increase line size accordingly.

High-stage compressor units may be supplied with single-port (low Vi, side, or closed thread) or dual-port (low Vi and high Vi), liquid injection oil cooling. Single port will be furnished for low compression ratio operation and dual port for high compression ratio operation. Booster compressor units use single-port (High Vi), liquid injection oil cooling due to the typically lower compression ratios.

The control system on high-stage units with dual-port, liquid injection oil cooling switches the liquid refrigerant supply to the high port when the compressor is operating at higher compression ratios (3.5 Vi and above) for best efficiency.

Where low compression ratios (low condensing pressures) are anticipated, thermosyphon or water-cooled oil cooling should be used.

CAUTION It is imperative that an uninterrupted high-pressure liquid refrigerant be provided to the injection system at all times. Two items of EXTREME IMPORTANCE are the design of the receiver/liquid injection supply and the size of the liquid line. It is recommended that the receiver be oversized sufficiently to retain a 5-minute supply of refrigerant for oil cooling. The evaporator supply must be secondary to this consideration. Failure to follow these requirements causes wire draw which can result in damage to the expansion valve, loss of oil cooling, and intermittent oil cooling. One method of accomplishing this is described below.

DUAL DIP TUBE METHOD

The dual dip tube method uses two dip tubes in the receiver. The liquid injection tube is below the evaporator tube to assure continued oil cooling when the receiver level is low. See Figure 6.

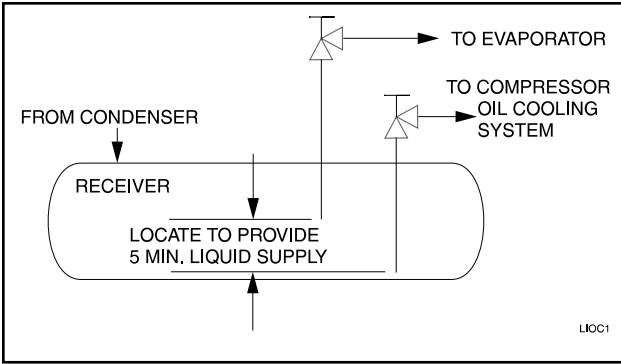

Figure 6

ECONOMIZER - HIGH STAGE (OPTIONAL)

The economizer option provides an increase in system capacity and efficiency by subcooling liquid from the condenser through a heat exchanger or flash tank before it goes to the evaporator. The subcooling is provided by flashing liquid in the economizer cooler to an intermediate pressure level. The intermediate pressure is provided by a port located part way down the compression process on the screw compressor.

As the screw compressor unloads, the economizer port will drop in pressure level, eventually being fully open to suction. Because of this, an output from the microprocessor is generally used to turn off the supply of flashing liquid on a shell and coil or DX economizer when the capacity falls below approximately 60%-70% (85%-90% slide valve position). This is done to improve compressor operating efficiency. Please note however that shell and coil and DX economizers can be used at low compressor capacities in cases where efficiency is not as important as ensuring that the liquid supply is subcooled. In such cases, the economizer liquid solenoid can be left open whenever the compressor is running.

Due to the tendency of the port pressure to fall with decreasing compressor capacity, a back-pressure regulator valve (BPR) is generally required on a flash economizer system (Figure 9) in order to maintain some preset pressure difference between the subcooled liquid in the flash vessel and the evaporators. If the back-pressure regulator valve is not used on a flash economizer, it is possible that no pressure difference will exist to drive liquid from the flash vessel to the evaporators, since the flash vessel will be at suction pressure. In cases where wide swings in pressure are anticipated in the flash economizer vessel, it may be necessary to add an outlet pressure regulator to the flash vessel outlet to avoid overpressurizing the economizer port, which could result in motor overload. Example: A system feeding liquid to the flash vessel in batches.

The recommended economizer systems are shown in Figures 7 – 10. Notice that in all systems there must be a strainer and a check valve between the economizer vessel and the economizer port on the compressor. The strainer prevents dirt from passing into the compressor and the check valve prevents oil from flowing from the compressor unit to the economizer vessel during shutdown.

CAUTION Other than the isolation valve needed for strainer cleaning, it is essential that the strainer be the last device in the economizer line before the compressor. The strainer must be strong enough to handle the gas pulsations from the compressor. Frick recommends an R/S or Hansen strainer. Also, piston-type check valves are recommended for installation in the economizer line, as opposed to disc-type check valves. The latter are more prone to gas-pulsation-induced failure. The isolation and check valves and strainer should be located as closely as possible to the compressor, preferably within a few feet.

For refrigeration plants employing multiple compressors on a common economizing vessel, regardless of economizer

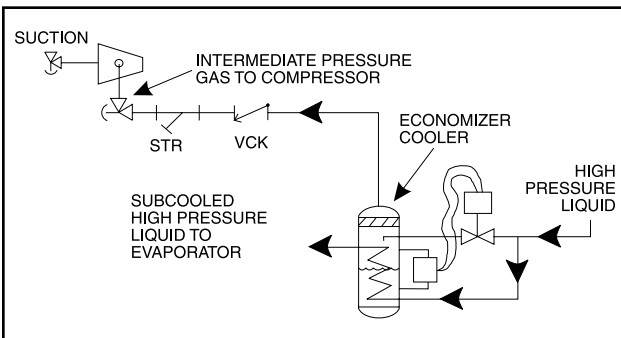

Figure 7 - Shell And Coil Economizer System

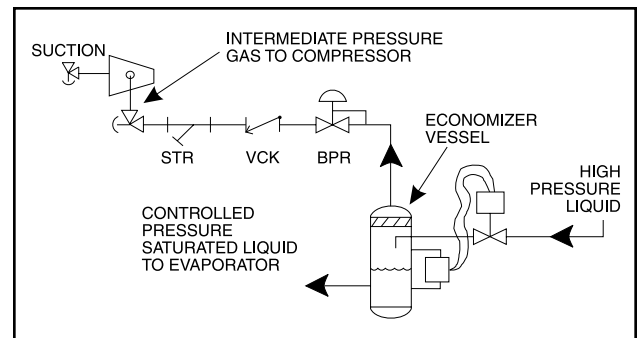

Figure 9 - Flash Economizer System

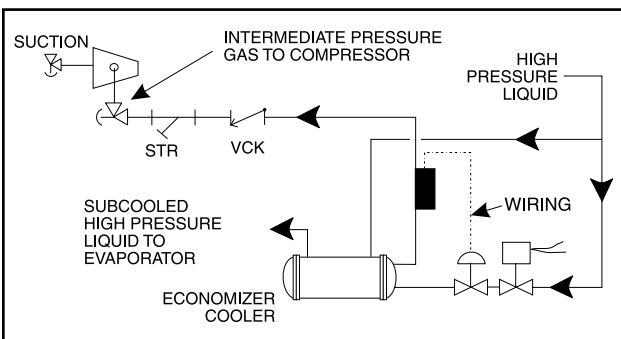

Figure 8 - Direct Expansion Economizer System

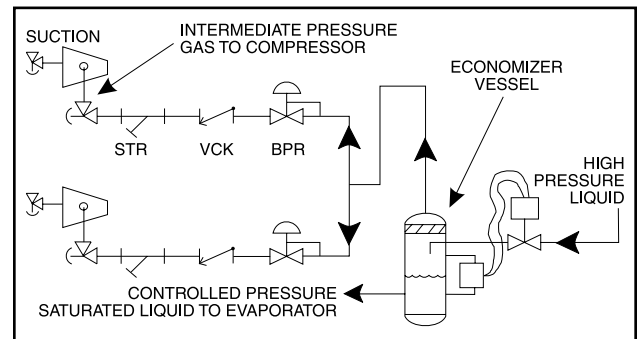

Figure 10 - Multiple Compressor Flash Economizer System

type, each compressor must have a back-pressure regulating valve in order to balance the economizer load, or gas flow, between compressors. The problem of balancing load becomes most important when one or more compressors run at partial load, exposing the economizer port to suction pressure. In the case of a flash vessel, there is no need for the redundancy of a back-pressure regulating valve on the vessel and each of the multiple compressors. Omit the BPR valve on the flash economizer vessel and use one on each compressor, as shown in Figure 10.

ELECTRICAL

NOTE: Before beginning electrical installation, read the instructions in the section "Proper Installation of Electronic Equipment" at the back of this manual.

RXF units are supplied with a **QUANTUM™ LX** control system. Care must be taken that the controls are not exposed to physical damage during handling, storage, and installation. The single-box control door must be kept tightly closed to prevent moisture and foreign matter from entry.

WARNING Customer connections are made in the Quantum™ LX control panel* mounted on the unit. The electrical enclosures should be kept tightly closed whenever work is not being done inside. * Or starter panel (if provided).

VOLTAGE PROTECTION

Frick® does not advise nor support the use of UPS power systems in front of the Quantum™ LX panel. With a UPS power system providing shutdown protection for the Quantum™ LX, the panel may not see the loss of the 3-phase voltage on the motor because the UPS could prevent the motor starter contactor from dropping out. With the starter contactor still energized, the compressor auxiliary will continue to feed an "Okay" signal to the panel. This will allow the motor to be subjected to a fault condition on the 3-phase bus. Some fault scenarios are:

1. The 3-phase bus has power "on" and "off" in a continuous cyclic manner which may cause the motor to overheat due to repeated excessive in-rush currents.
2. Motor cycling may damage the coupling or cause other mechanical damage due to the repeated high torque motor "bumps".
3. Prolonged low voltage may cause the motor to stall and overheat before the motor contactor is manually turned off.

Under normal conditions, the loss of 3-phase power will shut down the Quantum™ LX panel, and it will restart upon power return. If the panel is in:

- **Auto** – Compressor motor will return to running as programmed.
- **Remote** – The external controller would reinitialize the panel and proceed to run as required.
- **Manual** – The compressor will have to be restarted manually after the 3-phase bus fault has been cleared.

If the local power distribution system is unstable or prone to problems, there are other recommendations to satisfy these problems. If power spikes or low or high line voltages are the

problem, then Frick® recommends the use of a Sola® constant voltage (CV) transformer with a line suppression feature. If a phase loss occurs, then you will typically get a high motor amp shutdown. If problems continue to exist, then an examination of the plant's power factor may be in order.

Unless careful design failure analysis is considered in the implementation of power systems, the alternative solutions provide a safer and less expensive implementation. In either case, only one Sola® may be used per compressor. Each compressor needs to be individually isolated from each other through a dedicated control transformer. Sharing a common control power source is an invitation for ground loops and the subsequent unexplainable problems.

MOTOR STARTER PACKAGE

CAUTION When starting at full voltage or across-the-line, a shunting device must be installed or the Analog I/O board in the Quantum™ LX panel may be severely damaged at start-up. See Figure 10.

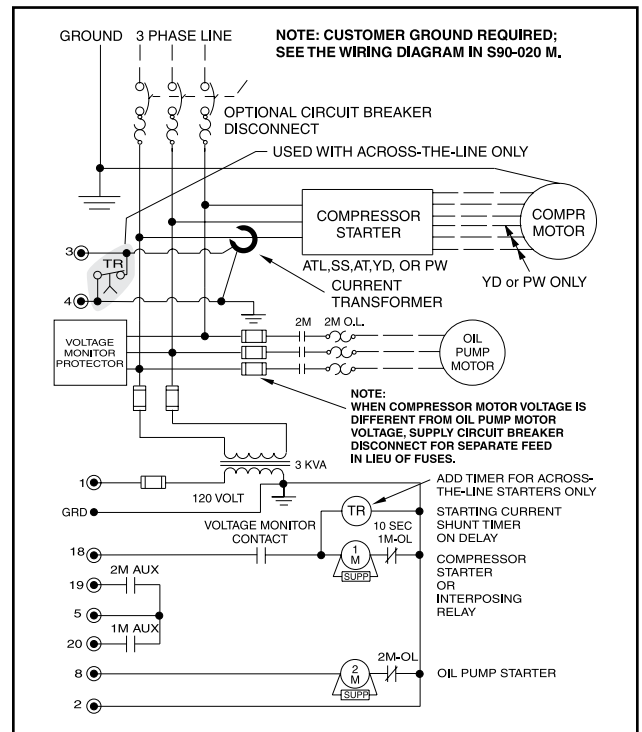

Figure 10 - Starter Wiring Diagram

Motor starter and interlock wiring requirements are shown in the diagram, Figure 10. All of the equipment shown is supplied by the installer unless a starter package is purchased separately from Frick. Starter packages should consist of:

1. The compressor motor starter of the specified horsepower and voltage for the starting method specified (across-the-line, autotransformer, wye-delta or solid-state).

NOTE: If starting methods other than across-the-line are desired, a motor/compressor torque analysis must be done to ensure sufficient starting torque is available. Contact Frick if assistance is required.

2. If specified, the starter package can be supplied as a combination starter with circuit breaker disconnect. However, the motor overcurrent protection/disconnection device can

be applied by others, usually as a part of an electrical power distribution board.

3. A 3.0 KVA control power transformer (CPT) to supply 120 volt control power to the control system and separator oil heaters is included. If environmental conditions require more than 2000 watts of heat, an appropriately oversized control transformer will be required.

4. One normally open compressor motor starter auxiliary contact should be supplied and wired as shown on the starter package wiring diagram. In addition, the compressor starter coil and the CPT secondaries should be wired as shown on the starter package wiring diagram, Figure 10.

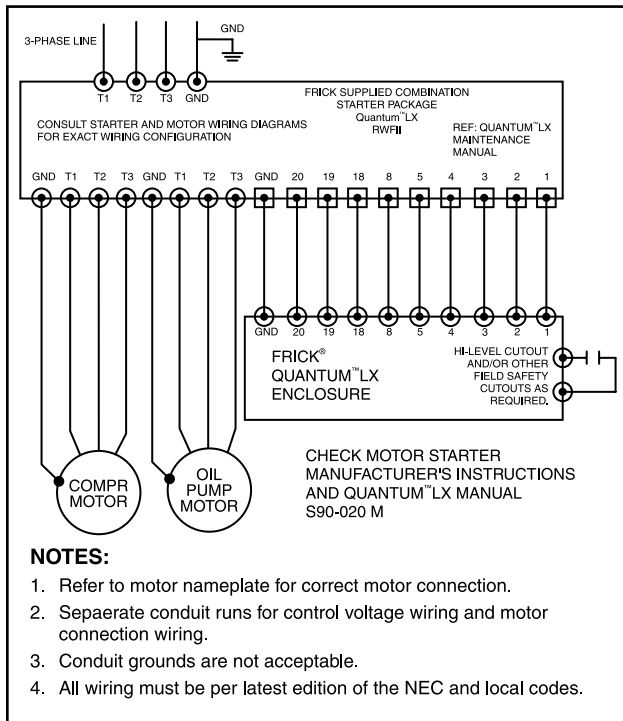

Figure 11 - Point-to-Point Wiring Diagram

5. The compressor motor Current Transformer (CT) can be installed on any one phase of the compressor leads. **NOTE: the CT must see all the current on any one phase, therefore in wye-delta applications BOTH leads of any one phase must pass through the CT.**

CURRENT TRANSFORMER SIZE

Calculate (CT) size using the following formula where SF is Service Factor and FLA is Full Load Amps of the Motor.

$$FLA \times SF \times 1.1$$

(round up to the next hundred)

Example: FLA = 379; Service Factor = 1.15

$$379 \times 1.15 \times 1.1 = 479$$

Use a 500:5 CT

DO NOT use undersized current transformers since the panel will not be capable of reading potential current. If the CT is higher than calculated, enter it's value for [CT Factor] on the panel. The unit can operate with a CT one size larger than calculated, however, replace with the proper size ASAP. **DO NOT** operate unit with a CT more than one size larger than recommended.

MINIMUM BURDEN RATINGS

The following table gives the minimum CT burden ratings. This is a function of the distance between the motor starting package and the compressor unit.

BURDEN RATING		MAXIMUM DISTANCE FROM FRICK PANEL		
ANSI	VA	USING # 14 AWG	USING # 12 AWG	USING # 10 AWG
B-0.1	2.5	15 ft	25 ft	40 ft
B-0.2	5	35 ft	55 ft	88 ft
B-0.5	12.5	93 ft	148 ft	236 ft

NOTE: Do not install a compressor HAND/OFF/AUTO switch in the starter package as this would bypass the compressor safety devices.

CONTROL POWER REGULATOR

Compressor units that will be used in areas that suffer brown-outs and other significant power fluctuations can be supplied with a control power regulator. See Figure 12, Recommended Regulator Installation.

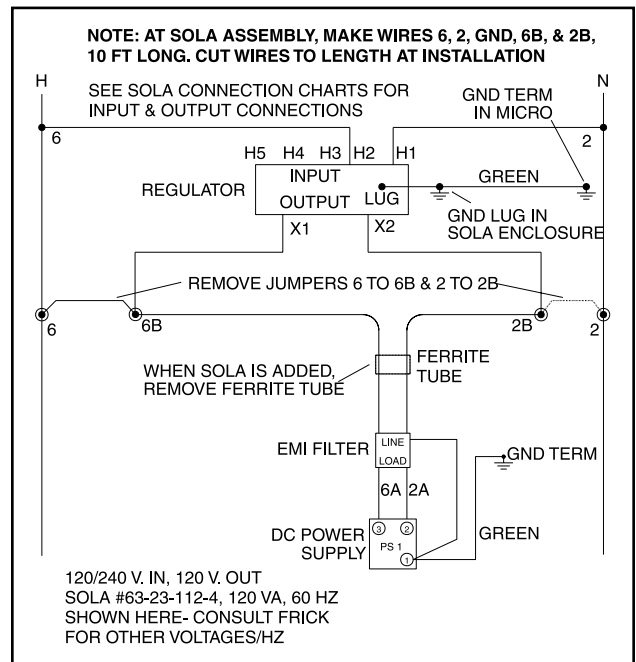

Figure 12 - Recommended Regulator Installation

Operation

OPERATION and START-UP INSTRUCTIONS

The Frick RXF Rotary Screw Compressor Unit is an integrated system consisting of six major subsystems:

Control Panel – See publications 090-020 O, M, & CS (also 090-021 & -022 O) for *QUANTUM™ LX*; Compressor; Compressor Lubrication System; Compressor Oil Separation System; Compressor Hydraulic System; Compressor Oil Cooling System.

The information in this section of the manual provides the logical step-by-step instructions to properly start up and operate the RXF Rotary Screw Compressor Unit.

NOTE: For alarm descriptions and shutdown or cutout parameters, see publication 090-020, -021, -022 O.



**THE FOLLOWING SUBSECTIONS
MUST BE READ AND UNDER-
STOOD BEFORE ATTEMPTING TO
START OR OPERATE THE UNIT.**

START OR OPERATE THE UNIT.

RXF COMPRESSOR

The Frick **RXF** rotary screw compressor utilizes mating asymmetrical profile helical rotors to provide a continuous flow of refrigerant vapor and is designed for high pressure applications. The compressor incorporates the following features:

1. High capacity roller bearings to carry radial loads at both the inlet and outlet ends of the compressor.
2. Heavy-duty angular contact ball bearings to carry axial loads are mounted at the discharge end of compressor.
3. Moveable slide valve to provide infinite step capacity control from 100% to 25% of full load capacity.
4. **VOLUMIZER® II** adjusts to the most efficient of three volume ratios (2.2, 3.5 or 5.0) depending upon system requirements.
5. Hydraulic cylinders to operate the slide valve.
6. Compressor housing suitable for 350 PSI pressure.
7. Most bearing and control oil is vented to closed threads in the compressor instead of suction port to avoid performance penalties from superheating suction gas.
8. The shaft seal is designed to maintain operating pressure on the seal well below discharge pressure for increased seal life.
9. Oil is injected into the rotors to maintain good volumetric and adiabatic efficiency, even at very high compression ratios.



It is mandatory that the coupling center be removed and the direction of motor rotation be confirmed before running the compressor. Proper rotation of the compressor shaft is clockwise looking at the end of the compressor shaft. Failure to follow this step could result in backward compressor rotation which can cause compressor failure or explosion of the suction housing.

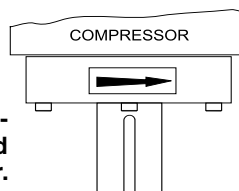

COMPRESSOR LUBRICATION SYSTEM

The **RXF** compressor is designed specifically for operation without an oil pump for high stage service. Boosters and some low-differential pressure applications will require the demand pump option.

The lubrication system on an **RXF** screw compressor unit performs several functions:

1. Lubricates the rotor contact area, allowing the male rotor to drive the female rotor on a cushioning film of oil.
2. Provides lubrication of the bearings and shaft seal.
3. Serves to remove the heat of compression from the gas, keeping discharge temperatures low and minimizing refrigerant or oil breakdown.
4. Fills gas leakage paths between or around the rotors with oil, thus greatly reducing gas leakage and maintaining good compressor performance even at high compression ratios.
5. Provides oil pressure for development of balance load on the balance pistons to reduce bearing loading and increase bearing life.

NO PUMP OIL SYSTEM

The RXF screw compressor unit is designed to be self-lubricating. Oil being supplied to the compressor from the oil separator is at system head pressure. Within the compressor, oil porting to all parts of the compressor is vented back to a point in the compressor's body that is at a pressure lower than compressor discharge pressure. The compressor's normal operation makes the compressor unit operate essentially as its own oil pump. All oil entering the compressor is moved by the compressor rotors out the compressor outlet and back to the oil separator. For normal high-stage operation an oil pump is not required.

COLD-START SYSTEM

The RXF package is equipped with a special "cold-start" discharge check valve on the gas outlet connection of the oil separator. This valve causes the oil separator to develop oil pressure rapidly on initial start in order to lubricate the compressor without requiring an oil pump, even in cold ambient temperatures with all pressures equalized. See Figure 13.

For high-stage packages, the cold-start valve is equipped with a large spring that creates 30 psi of pressure in the oil separator (above suction pressure), for lubrication of the compressor.



**DO NOT ATTEMPT TO SERVICE THE
COLD-START VALVE. PLEASE CON-
TACT THE FRICK SERVICE
DEPARTMENT.**

Once the compressor is running it will begin to force gas to the condenser at connection P2. See Figure 13. As the condenser heats up it will begin to rise in pressure as the compressor suction pulls down in pressure. As soon as differential pressure is developed between the condenser and suction, these pressures act across a piston inside the cold-start valve to partially overcome the spring force. When the differential pressure reaches and exceeds 30 psi, the piston fully overcomes the spring force and powers the valve fully open for very low operating pressure drop.

For booster applications, the valve is equipped with a lighter spring which produces 1/2 bar (7 psig) oil pressure above

suction pressure before it fully powers open. The heavier spring is not required because booster compressors are equipped with a demand oil pump.

The RXF package is also equipped with a suction check valve bypass. The oil separator will slowly bleed down to system suction pressure when the unit is stopped. This allows the compressor drive motor to have an easier start, and the discharge check valve will seat more tightly. See the "SUCTION CHECK VALVE BYPASS" section for operation.

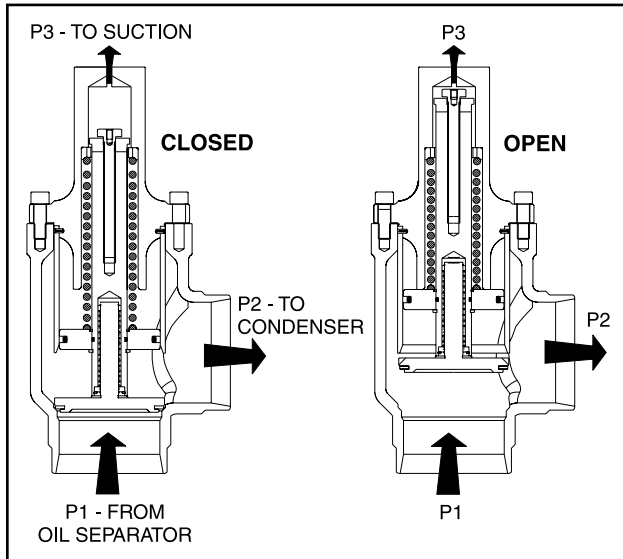

Figure 13

DEMAND PUMP OIL SYSTEM

This system is designed to provide adequate compressor lubrication for some high stage applications that operate with low differential pressure across the compressor suction and discharge and all booster applications.

On start-up, Quantum™ LX will calculate the pressure differential between the compressor discharge and the main oil injection port. If this differential is less than 35 psi, then the demand pump will turn on and will continue to run until 45 psi differential is obtained. Then, the pump will shut down and start only when the differential pressure falls below 35 psi.

NOTE: For alarm descriptions and shutdown or cutout parameters, see publication 090-020 O.

COMPRESSOR OIL SEPARATION SYSTEM

The RXF is an oil-flooded screw compressor. Most of the oil discharged by the compressor separates from the gas flow in the oil charge reservoir. Some oil, however, is discharged as a mist which does not separate readily from the gas flow and is carried past the oil charge reservoir. The coalescer filter element then coalesces the oil mist into droplets, the droplets of oil fall to the bottom of the coalescer section of the oil separator. The return of this oil to the compressor is controlled by a hand expansion valve (HV1). See Figure 14.

NOTE: Open HV1 only enough to keep the coalescer end of the separator free of oil.

The sight glass located near the bottom of the coalescer section of the oil separator should remain empty during normal operation. If an oil level develops and remains in the sight glass, a problem in the oil return separation system or

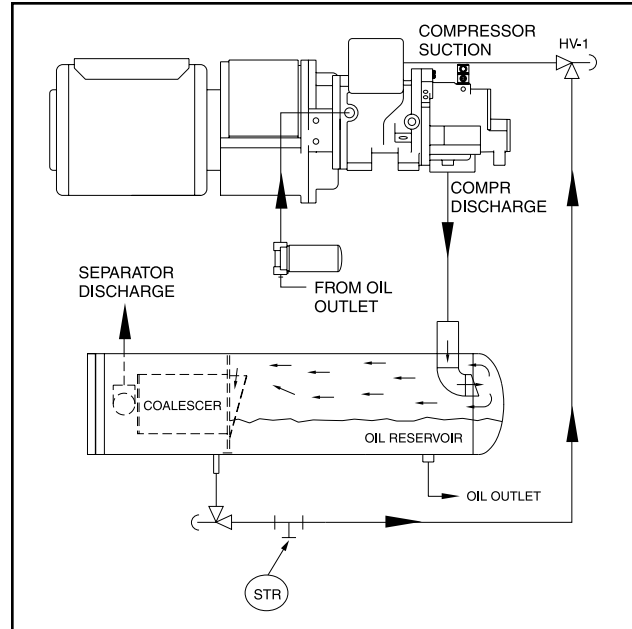

Figure 14

compressor operation has developed. Refer to Maintenance for information on how to correct the problem.

NOTE: Normal operating level is between the top sight glass and bottom sight glass located midway along the oil separator shell.

COMPRESSOR HYDRAULIC SYSTEM

The hydraulic system of the RXF compressor utilizes oil pressure from internally drilled passages in the compressor casing to selectively load and unload the compressor by applying this pressure to the actuating hydraulic piston of the movable slide valve (MSV). It also uses oil pressure to actuate a hydraulic piston that moves the movable slide stop, Volumizer® II. This allows adjustment of the compressor volume ratio, (Vi) while the compressor is running.

CAPACITY CONTROL

COMPRESSOR LOADING: The compressor loads when MSV solenoid coil YY2 is energized and oil flows from the solenoid valve through the needle valve (HV2) to compressor port 2, where it enters the load side of the slide valve piston. This equalizes the force on the slide valve piston and discharge pressure on the slide valve area loads the compressor. See Figure 15.

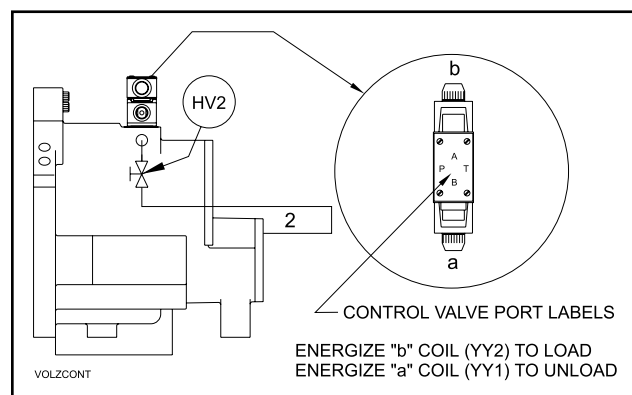

Figure 15

COMPRESSOR UNLOADING: The compressor unloads when MSV solenoid YY1 is energized and oil is allowed to flow from compressor port 2 thru the needle valve to the MSV solenoid. This allows discharge pressure on the slide valve piston to unload the slide valve as the piston moves outward.

ADJUSTMENT (Capacity Control): A needle valve (HV2) is provided to adjust slide valve travel time, preventing excessive slide valve “hunting”. HV2 should be adjusted to restrict oil flow to the compressor port so that slide valve travel time from full load to full unload, or vice versa, is a minimum of 30 seconds.

NOTE: A change in operating conditions, such as winter-to-summer operation, may require readjustment of slide valve travel time.

VOLUMIZER® II Vi CONTROL

The RXF compressor is equipped with a special internal control that automatically adjusts the compressor volume ratio to the most efficient of three available steps, (2.2, 3.5, or 5.0 volume ratio). This gives the compressor the ability to operate at varying operating conditions while minimizing power consumption by avoiding over or undercompression.

Solenoid valves 3 and 4 (See Figures 16 - 18 and location on P & I diagram represented by YY3 and YY4) control the Volumizer® II volume ratio control. Oil is internally ported to apply hydraulic pressure to two stepping pistons in order to move the moveable slide stop to the optimum position. The following chart shows the logic of solenoid operation to adjust the volume ratio.

Vi	SOLENOID 3 / YY3	SOLENOID 4 / YY4
2.2	Energized	Energized
3.5	Deenergized	Energized
5.0	Deenergized	Deenergized

Proper operation of the Volumizer® II control can be checked as follows.

1. Confirm that the slide valve travel number in Factory Setup is set at 190 degrees. If necessary, adjust the setting to 190 degrees before proceeding further.
2. Set the compressor Vi to 2.2, then record the voltage that is shown on the Slide Valve calibration screen for the current Slide Valve and 0% Slide Valve positions. The difference between these voltages must be in the 1.35 - 1.65 Vdc range.
3. Set the compressor Vi to 3.5, then record the voltage that is shown on the Slide Valve calibration screen for the current Slide Valve and 0% Slide Valve positions. The difference between these voltages must be in the 0.95 - 1.15 Vdc range.
4. Set the compressor Vi to 5.0, then record the voltage that is shown on the Slide Valve calibration screen for the current Slide Valve and 0% Slide Valve positions. The difference between these voltages must be in the 0.73 - 0.93 Vdc range.
5. If the above voltage measurements are all in range, the Volumizer® II is working properly. If any of the voltages are out of range, go to the troubleshooting section.

Proper installation of the Vi control valves and gaskets is essential to the operation of this equipment. Incorrectly installed parts may cause the compressor to operate at the wrong Vi, or to load or unload improperly. Operation at the wrong compressor Vi can cause excessive power consumption, noise,

vibration, or excessive oil foaming. See Figures 16 - 18 for correct installation of gaskets and location of solenoids.

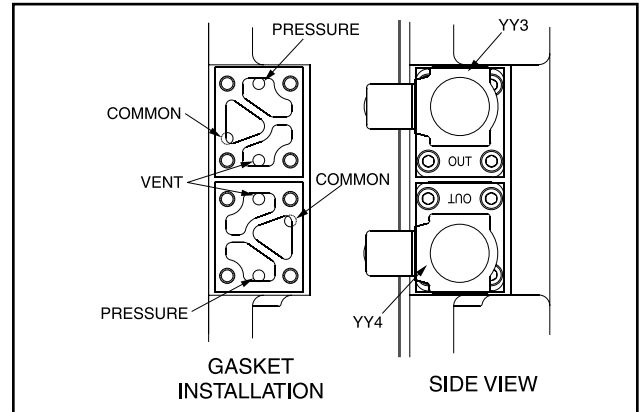

Figure 16 - RXF 12-19 Vi Control

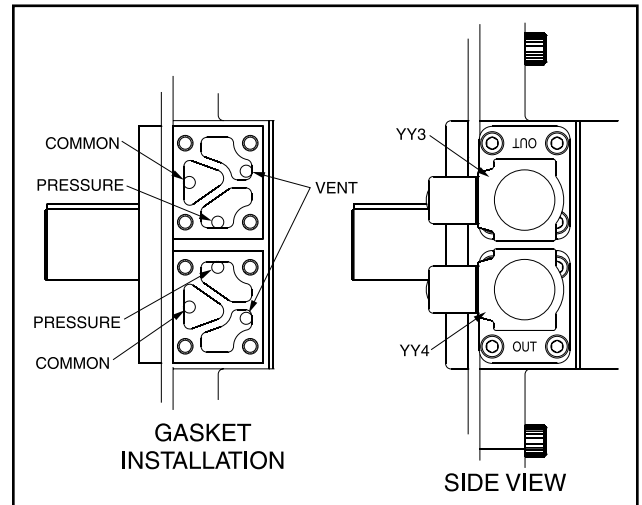

Figure 17 - RXF 24-50 Vi Control

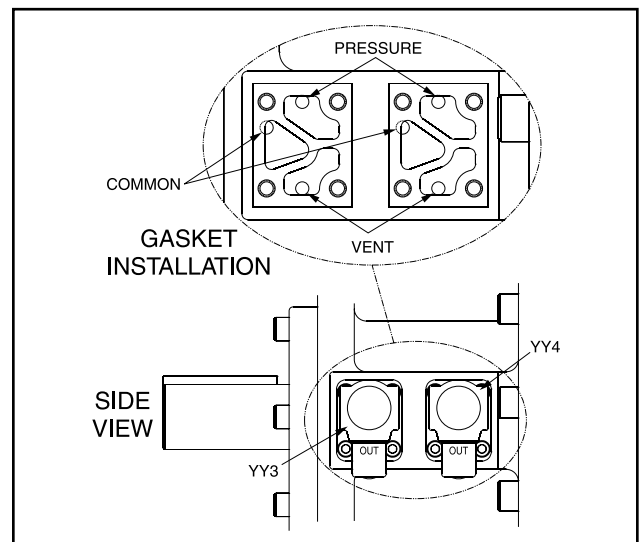

Figure 18 - RXF 58-101 Vi Control

SLIDE VALVE CALIBRATION

Slide valve calibration is performed on the Quantum™LX control panel in automatic mode. If further problems occur or persist, contact Frick service.

COMPRESSOR OIL COOLING SYSTEMS

The RXF unit can be equipped with one of several systems for controlling the compressor oil temperature. They are single or dual-port liquid injection, thermosyphon, or water-cooled oil coolers. Each system is automatically controlled, independent of compressor loading or unloading.

Oil cooling systems maintain oil temperature within the following ranges for R-717 and R-22:

- Liquid Injection Oil Cooling - 130 - 150°F
- External* Oil Cooling - 120 - 140°F

* Thermosyphon Oil Cooling (TSOC) or Water-Cooled Oil Cooling (WCOC).

SINGLE-PORT LIQUID INJECTION

The single-port liquid injection system is designed to permit liquid refrigerant injection into one port on the compressor at any given moment and operates as outlined.

The liquid injection solenoid valve is energized by the microprocessor when the temperature sensor, installed in the compressor discharge, exceeds the setpoint. High-pressure liquid refrigerant is then supplied to the motorized expansion valve. **Refer to P & I DIAGRAMS section for piping and instrumentation drawings.**

DUAL-PORT LIQUID INJECTION

The dual-port liquid injection system is designed to obtain the most efficient compressor performance at high and low compression ratios by permitting injection of liquid refrigerant into one of two ports optimally located on the compressor.

This minimizes the performance penalty incurred with liquid injection oil cooling.

The dual-port system contains all the components of the single-port system with the addition of a double-acting solenoid valve and operates as outlined.

The liquid injection solenoid valve is energized by the microprocessor when the temperature sensor, installed in the compressor discharge, exceeds the setpoint. Liquid refrigerant is then passed through the motorized expansion valve to the double-acting solenoid valve. Depending on the compressor's operating volume ratio (Vi), the microprocessor will select the flow of the liquid refrigerant to the optimum compressor port.

QUANTUM™LX EZ-COOL™ LIQUID INJECTION ADJUSTMENT PROCEDURE

Use the following directions to set up and tune the EZ-Cool™ LIOC with a Quantum™LX Control Panel. Also refer to publication 090-022 O, Quantum™LX Operation, for an overview of PID control.

First, complete calibration of the analog output used for EZ-Cool™ LIOC. Typically, this will be analog output #1 for PID #1.

- Power down the panel and remove the two control wires for the valve from terminals 1 & 2 of the P11A terminal strip of analog board #1.
- Place the leads of a calibrated, quality meter to terminal one (positive) and terminal two (negative). Set the meter to read mA DC and power up the panel.
- Set operating session to Session 2 and go to the screen shown in Figure 19 by pressing **[Menu] > [Calibration] > [Analog Outputs] > [Output Calibration]**.

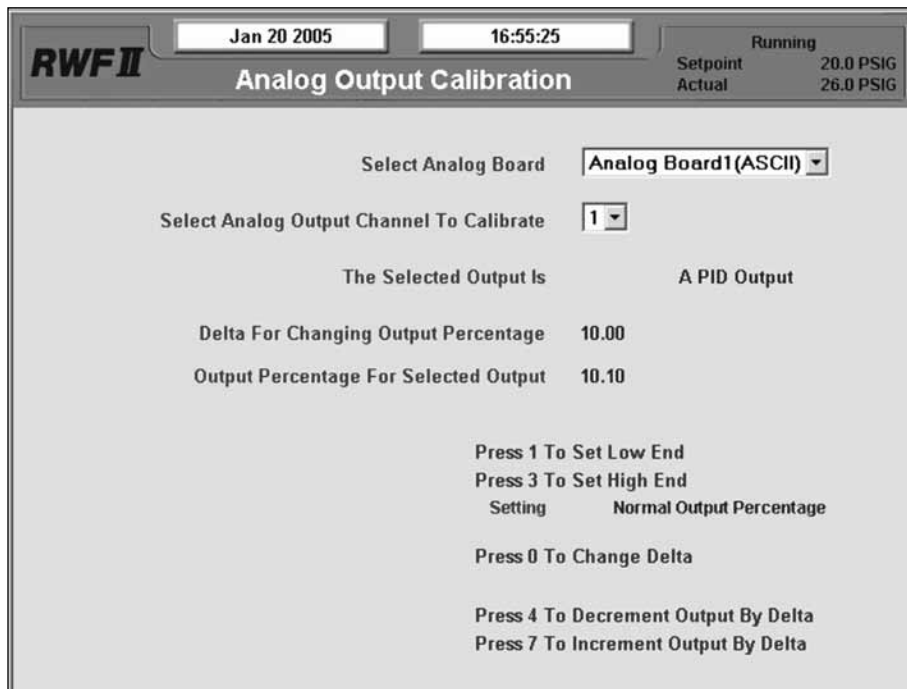

Figure 19

- Press **[1]** on the keypad to drive the output to the low end. Using numbers **[4]**, **[7]**, and **[0]** on the keypad to increase and decrease the output and change the "Delta For Changing Output Percentage" setpoint, set the output to 4mA.
- If the read value is less than the objective of 4 or 20mA use **[7]** on the keypad to increase the output by the Delta. If the read value is more than the objective, use **[4]** to decrease the value by the Delta.

- Use the [0] key to change the Delta from 10 to 1, .10 or .01% to tune the output to the objective of 4 or 20mA.
- Press [3] on the keypad to set the output to the high end and repeat the process in the preceding steps to set the output to 20mA.
- Power down the panel, remove the meter and reconnect the control wires for the EZ-Cool™ LIOC valve as they were removed to terminals 1 & 2 of the P11A terminal strip of analog board #1.

Description of Proportional Band and Gain setpoints:

- **Proportional Band** – This setpoint determines the size of a region either above or below the Control Setpoint. Within this region the Proportional component of the PID Output value is the number between 0% and 100% that directly corresponds to the difference between the Control Input (Actual) and the Control Setpoint (Setpoint). Outside of this region the Proportional component is either 100% or 0%. If the PID Action is Forward, the Proportional Band extends above the Control Setpoint. If the PID Action is Reverse, the Proportional Band extends below the Control Setpoint.
- **Proportional Gain** - This value is calculated from the Proportional Band setpoint and is the same value that was entered as a Proportional Gain setpoint in the Quantum. The control setpoint will not be achieved with proportional control only. Integral control is needed to further correct the control input to achieve the setpoint.
- **Integral Gain** - This setpoint controls the influence the Integral component exerts on the PID Output value. The Integral component works to push the Control Input toward the Control Setpoint by tracking the difference between the Control Input and the Control Setpoint over time.
- **Derivative Gain** - This setpoint controls the influence the Derivative component exerts on the PID Output value. The Derivative component reacts to rapid changes in the value of the Control Input by predicting the direction the Control Input is traveling and then turning it back toward the Control Setpoint.

Example of Proportional Only Control:

Control Input: Discharge Temperature
 Control Setpoint: 150°F
 Dead Band: 0°F
 Proportional Band: 25
 Action: Forward

- Using the chart below, as long as the control input is 155°F the output will be at 20% with proportional control only. Integral control will increase the output in increments, over time, to correct the control input to the setpoint.

Control Input	Output %
150°F	0%
155°F	20%
160°F	40%
165°F	60%
170°F	80%
175°F	100%

Based on these descriptions set PID #1 for EZ-Cool™ LIOC per Figure 20 as a starting point. Tuning of the output will be required. There should be no need to use a derivative gain.

NOTES:

1. Set the “Liquid Slugging” Alarm and Shutdown setpoints to 90 to prevent nuisance shutdowns during the tuning process. Be sure to return these setpoints to their original values when finished.
2. While the discharge temperature will be the Control Point, it reacts quickly to adjustments. Be sure to allow an adjustment to the proportional band or integral gain setpoints the opportunity to counter and correct the control input (discharge temperature) before making additional adjustments.
3. Tune the output by making small adjustments of 1-5 to the Proportional Band and .1-.5 of the Integral Gain setpoints. Adjust only one at a time, allowing each adjustment time to settle out.

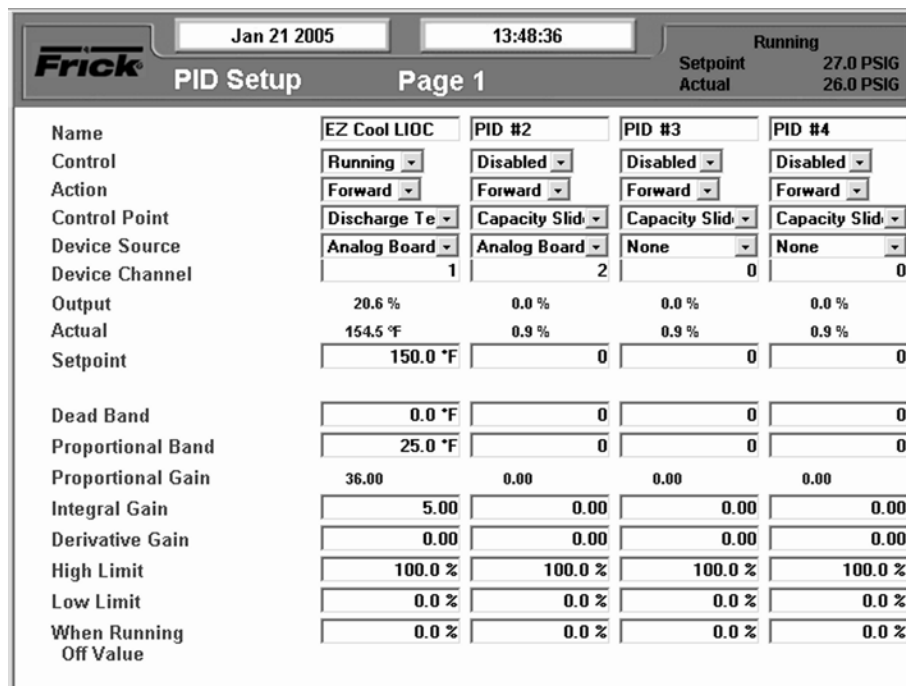

Figure 20

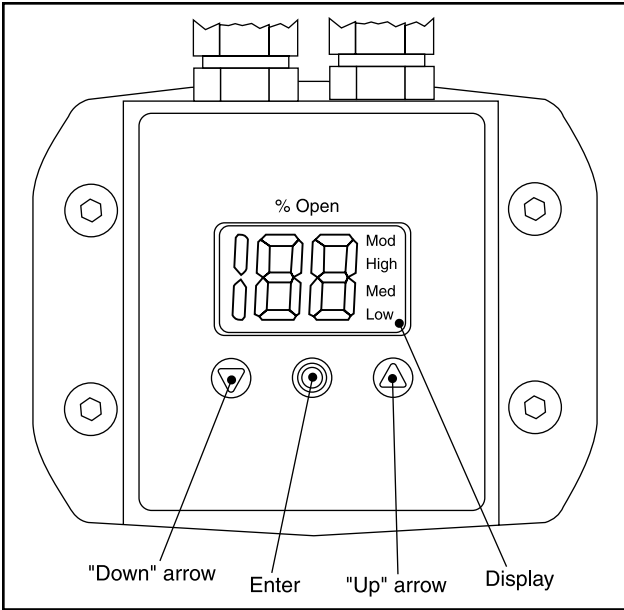

Figure 21

OPERATION OF DANFOSS LIQUID INJECTION VALVE

The Danfoss ICAD (Industrial Control Actuator with Display) is equipped with an LED Interface from which it is possible to monitor and change the setting of parameters to adapt the ICAD and the corresponding ICM (Motorized Industrial Control Valve) to the actual refrigeration application.

The setting of parameters is managed by means of the integrated ICAD (Figures 21 and 22) and consists of:

- “Down” arrow push button (Figures 21 and 22)
 - Decreases parameter number by 1 at each activation.
- “Up” arrow push button (Figures 21 and 22)
 - Increases parameter number by 1 at each activation.

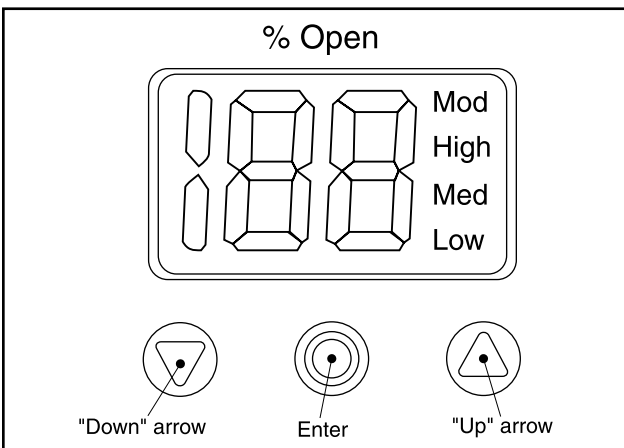

Figure 22

- Enter push button (Figures 21 and 22)
 - Gives access to the Parameter list by keeping the push button activated for 2 seconds. A Parameter list example is shown below (parameter i08, Figure 23).

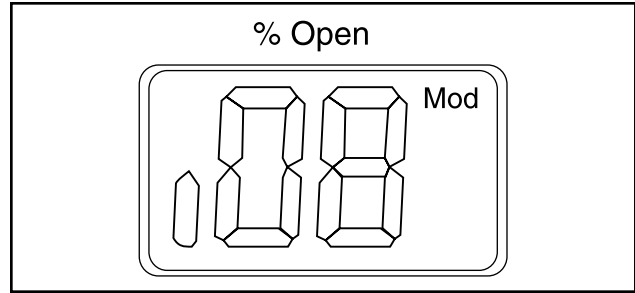

Figure 23

- Gives access to change a value once the Parameter list has been accessed.
- Acknowledge and save change of value of a parameter.
- To exit from the Parameter list and return to the display of Opening Degree (OD), keep the push button activated for 2 seconds.
- Display (Figure 24)
 - Normally the Opening Degree (OD) 0 - 100% of the ICM valve is displayed. No activation of push buttons for 20 seconds means that the display will always show 0 (Figure 23).

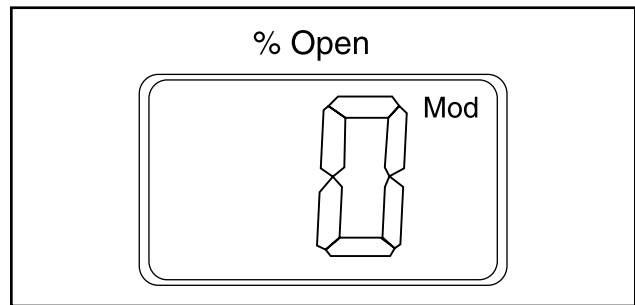

Figure 24

- Displays the parameter.
- Displays the actual value of a parameter.
- Displays the function status by means of text (Figure 21).
 - **Mod** represents that ICAD is positioning the ICM valve according to an analog input signal (Current).
 - **Low** represents that ICAD is operating the ICM valve like an ON/OFF solenoid valve with low speed according to a digital input signal.
 - **Med** represents that ICAD is operating the ICM valve like an ON/OFF solenoid valve with medium speed according to a digital Input signal.
 - **High** represents that ICAD is operating the ICM valve like an ON/OFF solenoid valve with high speed according to a digital input signal (Figure 25).

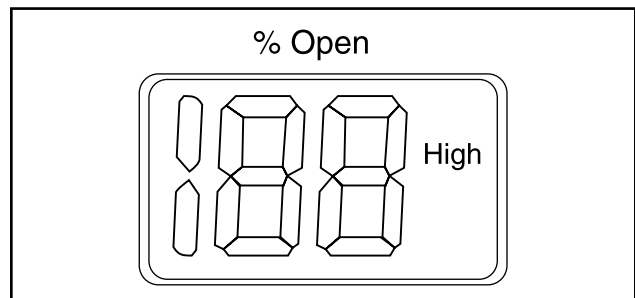

Figure 25

- Alarms
 - If an alarm has been detected the ICAD display (Figure 21) will alternate between showing Actual alarm and present Opening Degree.
 - If more than one alarm is active at the same time, the alarm with the highest priority will take preference. **A1** has the highest priority, **A3** the lowest.
 - All alarms will automatically reset themselves when they physically disappear.
 - Old alarms (alarms that have been active, but have physically disappeared again) can be found in parameter **j11**.

Typically motorized valves are factory set. If adjustments are needed, the following procedure can be used.

1. Ensure that there is power to the valve (24 VDC) and all wiring is complete prior to configuring the motorized valve. The ICAD 600 requires 1.2 amps for operation and the ICAD 900 requires 2.0 amps.

2. Identify which actuator is being used (ICAD 600 or 900) and which motorized valve is being used (ICM 20, 25, 32, 40, 50, or 65). Ensure that the correct actuator is being used with the ICM valve as follows:

- ICM20 with ICAD 600
- ICM25 with ICAD 600
- ICM32 with ICAD 600
- ICM40 with ICAD 900
- ICM50 with ICAD 900
- ICM65 with ICAD 900

3. When the valve is initially powered, A1 and CA will be flashing on the LED display. Hold the enter button down for two seconds until these values stop flashing.

4. Push the down arrow button and scroll until j10 is displayed and push the enter button. Using the up arrow, scroll until j11 is displayed and push the enter button. This step must be completed within 20 seconds or the valve will reset.

5. Push the down arrow button again and scroll until j26 is displayed and push the enter button. Identify the ICM valve being used and push the up arrow until the correct number is displayed for the ICM valve and then push the enter button. The values are as follows:

- 1 for ICM20
- 2 for ICM25
- 3 for ICM32
- 4 for ICM40
- 5 for ICM50
- 6 for ICM65

6. The ICAD will store these parameters with the power removed.

Alarms - ICAD can handle and display different alarms.

Description	ICM	Comments
	Alarm Text	
No valve type selected	A1	At start-up A1 and CA will be displayed
Controller fault	A2	Internal fault inside electronics
All input error	A3	When input amps are > 22 mA

Reset to factory setting:

1. Remove the power supply.
2. Activate down arrow and up arrow push buttons at the same time.
3. While continuing to push the down and up arrows, connect the power supply.
4. Release down arrow and up arrow push buttons.
5. When the display on ICAD (Figure 21) is alternating between showing: **CA** and **A1** the factory resetting is complete.

PARAMETER LIST

Description	Display Name	Min.	Max.	Factory Setting	Unit	Comments
ICM OD (Opening Degree)	-	0	100	-	%	ICM valve Opening Degree is displayed during normal operation. Running display value (see j01, j05).
Main Switch	j01	1	2	1	-	Internal main switch 1: Normal operation 2: Manual operation. Valve Opening Degree will be flashing. With the down arrow and the up arrow push buttons the OD can be entered manually.
Mode	j02	1	2	1	-	Operation mode 1: Modulating - ICM positioning according to Analogue input (see j03) 2: ON/OFF - operating the ICM valve like an ON/OFF solenoid valve controlled via Digital Input. See also j09.
Analog Input signal	j03	1	4	2	-	Type of Analog input signal from external controller 1: 0-20mA 2: 4-20mA 3: 0-10V 4: 2-10V
Speed at ON/OFF and Modulating Mode	j04	1	100	100	%	Speed can be decreased. Max. speed is 100 % Not active when j01 = 2 If j02 = 2, the display will indicate speed in display. Low, Med, and High also means ON/OFF operation. If j04 < = 33, Low is displayed 33 < j04 < = 66, Med is displayed If j04 > = 67, High is displayed
Automatic calibration	j05	0	1	0	-	Not active before j26 has been operated. Always auto reset to 0. CA will flash in the display during calibration.
Analog Output signal	j06	0	2	2	-	Type of A0 signal for ICM valve position 0: No signal 1: 0 - 20mA 2: 4 - 20mA
Fail-safe	j07	1	4	1	-	Define condition at power cut when fail-safe is installed. 1: Close valve 2: Open valve 3: Maintain valve position 4: Go to OD given by j12
Digital Input function	j09	1	2	1	-	Define function when DI is ON (short circuited DI terminals) when j02 = 2 1: Open ICM valve (DI = OFF => Close ICM valve) 2: Close ICM valve (DI = OFF => Open ICM valve)
Password	j10	0	199	0	-	Enter number to access password protected parameters: j26
Old Alarms	j11	A1	A99	-	-	Old alarms will be listed with the latest shown first. Alarm list can be reset by means of activating down arrow and up arrow at the same time for 2 seconds.
OD at powercut	j12	0	100	50	-	Only active if j07 = 4 If fail-safe supply is connected and powercut occurs, ICM will go to entered OD.
ICM configuration	j26	0	6	0	-	NB: Password protected. Password = 11 At first start-up, A1 will flash in display. Enter valve type. 0: No valve selected. Alarm A1 will become active. 1: ICM20 with ICAD 600 2: ICM25 with ICAD 600 3: ICM32 with ICAD 600 4: ICM40 with ICAD 900 5: ICM50 with ICAD 900 6: ICM65 with ICAD 900
OD%	j50	0	100	-	%	ICM valve Opening Degree
AI [mA]	j51	0	20	-	mA	Analog Input signal
AI [V]	j52	0	10	-	V	Analog Input signal
AO [mA]	j53	0	20	-	mA	Analog Output signal
DI	j54	0	1	-	-	Digital Input signal
DO Close	j55	0	1	-	-	Digital Output Closed status. ON when OD < 3%
DO Open	j56	0	1	-	-	Digital Output Open status. ON when OD > 97%
DO Alarm	j57	0	1	-	-	Digital Output alarm status. ON when an alarm is detected
MAS mP SW ver.	j58	0	100	-	-	Software version for MASTER Microprocessor
SLA mP SW ver.	j59	0	100	-	-	Software version for SLAVE Microprocessor

THERMOSYPHON OIL COOLING

Thermosyphon oil cooling is an economical, effective method for cooling oil on screw compressor units. Thermosyphon cooling utilizes liquid refrigerant at condenser pressure and temperature which is partially vaporized at the condenser temperature in a shell and tube or plate-type vessel, cooling the oil. The vapor, at condensing pressure, is vented to the condenser inlet and reliquified. This method is the most cost effective of all currently applied cooling systems since no compressor capacity loss or compressor power penalties are incurred. The vapor from the cooler need only be condensed, not compressed. Refrigerant flow to the cooler is automatic, driven by the thermosyphon principle, and cooling flow increases as the oil inlet temperature rises.

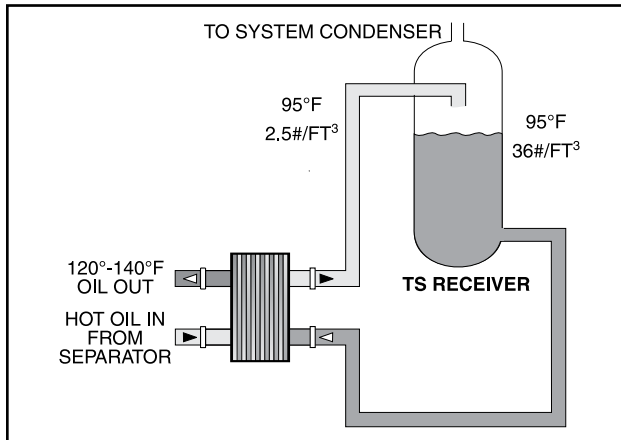

Figure 26

SYSTEM OPERATION: Liquid refrigerant fills the cooler. Warm or hot oil (above the liquid return temperature) flowing through the cooler will cause some of the refrigerant to boil and vaporize. The vapor rises in the return line.

The density of the refrigerant liquid/vapor mixture in the return line is considerably less than the density of the liquid in the supply line. This imbalance provides a differential pressure which sustains a flow condition to the oil cooler. This relationship involves:

1. Liquid height above the cooler.
2. Oil heat of rejection.
3. Cooler size and piping pressure drops.

Current thermosyphon systems are using single-pass oil coolers and flow rates based on 3:1 overfeed.

The liquid/vapor returned from the cooler is separated in the receiver. The vapor is vented to the condenser inlet and need only be reliquified since it is still at condenser pressure (see Figure 26).

INITIAL START-UP PROCEDURE

Having performed the checkpoints on the Prestart Checklist (see FORMS in Table of Contents), the compressor unit is ready for start-up. It is important that an adequate refrigerant load be available to load test the unit at normal operating conditions. The following points should be kept in mind during initial start-up.

1. On start-up the unit should be operated at as high a load possible for 3 hours. During the period, adjust liquid injection oil cooling, if applicable. If unit has water-cooled oil cooling, adjust water control valve to cooler (if applicable).
2. The compressor slide valve should be calibrated.
3. Pull and clean suction strainer after 24 hours operation. If it is excessively dirty, repeat every 24 hours until system is clean. Otherwise, follow the Maintenance Schedule. See the Recommended Maintenance Program section.

NORMAL START-UP PROCEDURE

1. Confirm system conditions permit starting the compressor.
2. Press the [RUN] key.
3. Allow the compressor to start up and stabilize. At start-up, the slide stop (volumizer) and the slide valve (capacity control) are in the **AUTO** mode.

RESTARTING COMPRESSOR UNIT AFTER CONTROL POWER INTERRUPTION (PLANT POWER FAILURE)

1. Check **ADJUSTABLE** setpoints.
2. Follow normal start-up procedure.

MAINTENANCE

This section provides instructions for normal maintenance, a recommended maintenance program, troubleshooting and correction guides, typical wiring diagrams and typical P and I diagrams.

WARNING

This section must be read and understood before attempting to perform any maintenance or service to the unit.

NORMAL MAINTENANCE OPERATIONS

When performing maintenance you must take several precautions to ensure your safety:

CAUTION

1. IF UNIT IS RUNNING, PUSH [STOP] KEY TO SHUT DOWN THE UNIT.
2. DISCONNECT POWER FROM UNIT BEFORE PERFORMING ANY MAINTENANCE.
3. WEAR PROPER SAFETY EQUIPMENT WHEN COMPRESSOR UNIT IS OPENED TO ATMOSPHERE.
4. ENSURE ADEQUATE VENTILATION.
5. TAKE NECESSARY SAFETY PRECAUTIONS REQUIRED FOR THE REFRIGERANT BEING USED.

WARNING

CLOSE ALL COMPRESSOR PACKAGE ISOLATION VALVES PRIOR TO SERVICING THE UNIT. FAILURE TO DO SO MAY RESULT IN SERIOUS INJURY.

GENERAL MAINTENANCE

Proper maintenance is important in order to assure long and trouble-free service from your screw compressor unit. Some areas critical to good compressor operation are:

1. Keep refrigerant and oil clean and dry, avoid moisture contamination. After servicing any portion of the refrigeration system, evacuate to remove moisture before returning to service. Water vapor condensing in the compressor while running, or more likely while shut down, can cause rusting of critical components and reduce life.
2. Keep suction strainer clean. Check periodically, particularly on new systems where welding slag or pipe scale could find its way to the compressor suction. Excessive dirt in the suction strainer could cause it to collapse, dumping particles into the compressor.
3. Keep oil filters clean. If filters show increasing pressure drop, indicating dirt or water, stop the compressor and change filters. Running a compressor for long periods with high filter pressure drop can starve the compressor for oil and lead to premature bearing failure.
4. Avoid slugging compressor with liquid refrigerant. While screw compressors are probably the most tolerant to ingestion of some refrigerant liquid of any compressor type available today, they are not liquid pumps. Make certain to maintain adequate superheat and properly size suction accumulators to avoid dumping liquid refrigerant into compressor suction.

Keep liquid injection valves properly adjusted and in good condition to avoid flooding compressor with liquid. Liquid can

cause a reduction in compressor life and in extreme cases can cause complete failure.

5. Protect the compressor during long periods of shut down. If the compressor will be setting for long periods without running it is advisable to evacuate to low pressure and charge with dry nitrogen or oil, particularly on systems known to contain water vapor.

6. Preventive maintenance inspection is recommended any time a compressor exhibits a noticeable change in vibration level, noise or performance.

COMPRESSOR SHUTDOWN and START-UP

For seasonal or prolonged (six months) shutdown, use the following procedure:

1. Push [STOP] key to shut down unit.
2. Open disconnect switch for compressor motor starter.
3. Turn off power.
4. Isolate the package by closing all package valves to the system. Tag all closed valves.

CAUTION

Open any solenoid valves or other valves that may trap liquid between the isolation valves and other package valves to prevent injury or damage to components.

5. With liquid injection, close the manual hand valve upstream of the solenoid and manually open the solenoid by turning "in" the manual opening stem (clockwise viewed from below valve).

6. Shut off the cooling water supply valve to the oil cooler. Drain water, if applicable. Attach **CLOSED** tags.

7. Protect oil cooler from ambient temperatures below freezing.

NOTE: The unit should be inspected monthly during shutdown. Check for leaks or abnormal pressure. Use the maintenance log to record readings to verify the pressure stability of the unit. To prevent the seals and bearing from drying out, run oil pump (if available) and manually rotate the compressor shaft. Consult motor manufacturer for motor recommendations.

TO START UP AFTER SEASONAL OR PROLONGED SHUTDOWN, USE THE FOLLOWING PROCEDURE :

1. Perform routine maintenance. Change oil and replace filters. Check strainers.
2. Any water necessary for the operation of the system that may have been drained or shut off should be restored or turned on.
3. Reset solenoid valves to automatic position, then open all valves previously closed. Remove tags.
4. Compressor unit is ready for prestart checks. Refer to **PRESTART CHECKLIST**.

COMPRESSOR/MOTOR SERVICING

Before removing the motor from an RXF unit, it is critical that proper support be provided for the compressor to prevent damage to the oil separator. Insert blocks or a jack

between the separator shell and compressor casting. Make sure the weight is held safely by the separator shell. Loosen the compressor discharge flange bolts to relax any flange and pipe stress, then carefully remove the motor. Similarly, before removing the compressor for servicing, the back end of the motor must be supported to prevent damage. Again, insert either blocks or a jack between the rear of the motor and the separator shell.

GENERAL INSTRUCTIONS FOR REPLACING COMPRESSOR UNIT COMPONENTS

When replacing or repairing components which are exposed to refrigerant, proceed as follows:

1. Push [STOP] key to shut down the unit.
2. Open disconnect switches for compressor motor starter and oil pump motor starter (if applicable).
3. Isolate the package by closing all package valves to the system. Tag all closed valves.

CAUTION Open any solenoid valves or other valves that may trap liquid between the isolation valves and other package valves to prevent injury or damage to components.

4. **SLOWLY** vent separator to low-side system pressure using the suction check valve bypass. **NOTE: Recover or transfer all refrigerant vapor, in accordance with local ordinances, before opening to atmosphere.** The separator **MUST** be equalized to atmospheric pressure.

CAUTION Oil entrained refrigerant may vaporize, causing a separator pressure increase. Repeat transfer and recovery procedure, if necessary.

5. Make replacement or repair.
6. Isolate the low pressure transducer, PE-4, to prevent damage during pressurization and leak test.
7. Pressurize unit and leak test.
8. Evacuate unit to 29.88" Hg (1000 microns).
9. Open all valves previously closed and reset solenoid valves to automatic position. Remove tags.
10. Close disconnect switches for compressor motor starter and oil pump motor starter, if applicable.
11. Unit is ready to put into operation.

OIL FILTER, SPIN-ON (RXF 12 – 50)

CAUTION Use of oil filters other than Frick may cause warranty claim to be denied.

To change the filter proceed as follows:

1. Push [STOP] key to shut down the unit. Open disconnect switches for the compressor.
2. Isolate the package by closing all package valves to the system. Tag all closed valves.

CAUTION Open any solenoid valves or other valves that may trap liquid between the isolation valves and other pack-

age valves to prevent injury or damage to components.

SLOWLY vent separator to low-side system pressure using the suction check valve bypass. **NOTE: Recover or transfer all refrigerant vapor, in accordance with local ordinances, before opening to atmosphere.** The separator **MUST** be equalized to atmospheric pressure.

CAUTION Oil entrained refrigerant may vaporize, causing a separator pressure increase. Repeat transfer and recovery procedure, if necessary.

3. Remove spin-on oil filter element and discard.
4. Replace with new oil filter element. Make finger tight plus an additional half turn.
5. Isolate the low pressure transducer, PE-4, to prevent damage during pressurization and leak test.
6. Pressurize and leak test. Evacuate unit to 29.88" Hg (1000 microns).
7. Open the suction and discharge service valves, and the low pressure transducer. Close disconnect switches for the compressor. Start the unit.

OIL FILTER, SINGLE ELEMENT (58 – 101)

CAUTION Use of filter elements other than Frick may cause warranty claim to be denied.

To change the filter cartridge proceed as follows:

1. If a single oil filter is installed, push [STOP] key to shut down the unit. Open disconnect switches for the compressor and (if applicable) oil pump motor starters.
2. Close discharge service valve. **SLOWLY** vent the separator to low-side system pressure using the suction check valve bypass. Close suction valve and suction check valve bypass. **NOTE: Recover or transfer all refrigerant vapor, in accordance with local ordinances, before opening to atmosphere. The oil filter cartridge MUST be equalized to atmospheric pressure before opening.**

CAUTION Oil-entrained refrigerant may vaporize, causing a pressure increase. Repeat venting and recovery procedure, if necessary.

3. Close oil filter isolation valves. Open drain valve on oil filter head and drain the oil. Remove the canister cover. Discard the cartridge and gasket.
4. Flush the filter body with clean Frick refrigeration oil; wipe dry with a clean, lint-free cloth; and close drain valve.
5. Place a new cartridge in the filter canister. Replace the gasket and spring and reinstall the canister cover. Torque cover bolts in sequence to:
 - a. Finger tight
 - b. 17 ft-lb
 - c. 35 ft-lb
6. Isolate the low pressure transducer, PE-4, to prevent damage during pressurization and leak test.
7. Pressurize and leak test. Evacuate the unit to 29.88" hg (1000 microns).
8. Add 2 gallons of oil by attaching a suitable pressure-type hose to the oil-charging valve located on top of the separator. Use a pressure-type oil pump and recommended Frick oil.

9. Open the suction and discharge service valves, oil filter isolation valves, and the low pressure transducer. Readjust suction check valve bypass. Close disconnect switches for the compressor and (if applicable) the oil pump motor starters. Start the unit.

COALESCER OIL RETURN STRAINER

1. Push **[STOP]** key to shut down the unit. Open disconnect switches for the compressor.

2. Isolate the package by closing all package valves to the system. Tag all closed valves.



Open any solenoid valves or other valves that may trap liquid between the isolation valves and other pack-

age valves to prevent injury or damage to components. SLOWLY vent separator to low-side system pressure using the suction check valve bypass. NOTE: Recover or transfer all refrigerant vapor, in accordance with local ordinances, before opening to atmosphere. The separator MUST be equalized to atmospheric pressure.



Oil entrained refrigerant may vaporize, causing a separator pressure increase. Repeat transfer and recovery procedure, if necessary.

3. Close strainer isolation valves. Remove the large plug from the bottom of the strainer and remove the element from the strainer.

4. Wash the element in solvent and blow clean with air.

5. Replace the cleaned element and removed plug. Open strainer isolation valves.

6. Isolate the low pressure transducer, PE-4, to prevent damage during pressurization and leak test.

7. Pressurize and leak test. Evacuate unit to 29.88" Hg (1000 microns).

8. Open the suction and discharge service valves, and the low pressure transducer. Close disconnect switches for the compressor. Start the unit.

LIQUID INJECTION STRAINER

To clean the liquid injection strainer the unit must be shut down. The procedure is as follows:

1. Push **[STOP]** key to shut down the unit, then open disconnect switches for the compressor.

2. Close the liquid supply service valve located before the liquid solenoid.

3. **Immediately screw in the manual solenoid valve stem to relieve liquid refrigerant pressure trapped between the solenoid and the service valve.**

4. Close the service valve located between the compressor and the liquid injection thermal expansion valve.

5. Carefully loosen capscrews securing the strainer cover to the strainer. Allow pressure to relieve slowly.

6. When all entrapped refrigerant has been relieved, carefully remove loosened capscrews (as liquid refrigerant is sometimes caught in the strainer), strainer cover, and strainer basket.

7. Wash the strainer basket and cover in solvent and blow clean with air.

8. Reassemble the strainer.

9. Open the service valve between the compressor and the liquid injection thermal expansion valve, purge entrained air, and check for leakage.

10. Screw out the manual solenoid valve stem.

11. Carefully open the liquid supply service valve.

12. Leak test.

13. Close disconnect switches for compressor starter.

14. Start the unit.

OIL PUMP STRAINER (Optional)

To clean the full-lube oil pump strainer, the unit must be shut down. The procedure is as follows:

1. Push **[STOP]** key to shut down the unit, then open the disconnect switches for the compressor and (if applicable) the oil pump motor starters.

2. Close strainer service valves.

3. Open the drain valve located in the strainer cover and drain the oil into a container.

4. Remove the capscrews securing the strainer cover, strainer cover gasket, and element. Retain the gasket.

5. Wash the element in solvent and blow it clean with air.

6. Wipe the strainer body cavity clean with a lint-free clean cloth.

7. Replace the cleaned element and gasket, then reattach the cover using the retained capscrews.

8. Reinstall the drain plug and open the strainer service valves.

9. Check for leakage.

10. Close the disconnect switches for the compressor and (if applicable) the oil pump motor starters.

11. Start the unit.

SUCTION CHECK VALVE BYPASS

A 1/4" angle valve is installed between the compressor and suction flange that can be used as a suction valve bypass. This feature has several uses including reducing starting torque, improving oil quality, and relieving the refrigerant to low side for servicing.

In most cases, the valve should be left open approximately 1 to 2 turns at all times. If the compressor back-spins or too much oil foaming is experienced while venting, partially close valve to slow speed of equalization. If system is on AUTO CYCLE and short cycling occurs, the valve must be closed.

To relieve refrigerant to low side, close separator discharge service valve. Slowly open bypass valve (if closed) and wait for pressure to equalize. Close bypass and suction service valves before evacuating the unit.

COALESCER FILTER ELEMENT



Use of coalescer filter elements other than Frick may cause warranty claim to be denied.

When changing the coalescer filter element, it is recommended that the oil and oil filter be changed. Applicable strainer elements should be removed and cleaned.

1. Refer to **CHANGING OIL**, Steps 1 thru 8.
2. Remove coalescer head and gasket. Discard the gasket.
3. Remove and retain nut securing coalescer filter retainer.
4. Remove retainer, coalescer filter element(s), and two O-rings. Discard the filter element(s).
5. Install new coalescer filter element(s). **NOTE: Frick Super-Coalescer™ element (with drain feature), on Models 24–101, must be installed with the "DRAIN DOWN" tag on the bottom at the 6 o'clock position.**



Seat element in center of locating tabs on separator bulkhead.

6. Replace coalescer filter retainer and nut. Tighten the nut to 21 ft/lb torque. **DO NOT OVERTIGHTEN NUT. Excessive torque can damage the element and result in oil carry-over.** Install jam nut and tighten.
7. Install a new head gasket and replace the coalescer head.
8. Tighten the head bolts, first to finger tight, then 65 ft-lb, then 130 ft-lb. **NOTE: WHEN THE COMPRESSOR UNIT IS REPRESSURIZED, RETIGHTEN SINCE HEAD BOLTS WILL LOOSEN.**
9. Refer to **CHANGING OIL**, Steps 9 thru 14.

CHANGING OIL



DO NOT MIX OILS of different brands, manufacturers, or types. Mixing of oils may cause excessive oil foaming, nuisance oil level cutouts, oil pressure loss, gas or oil leakage and catastrophic compressor failure.

Shut down the unit when changing oil. At the same time all oil filter cartridges must be changed and all oil strainer elements removed and cleaned. The procedure is as follows:

1. Push **[STOP]** key to shut down the unit.
2. Open disconnect switch for the compressor motor starter.
3. Close liquid injection service valves (if applicable).
4. Close discharge service valve. **SLOWLY** vent the separator to low-side system pressure using the suction check valve bypass. Close suction valve. **NOTE: Recover or transfer all refrigerant vapor, in accordance with local ordinances, before opening to atmosphere.** The separator **MUST** be equalized to atmospheric pressure.



Oil entrained refrigerant may vaporize, causing a separator pressure increase. Repeat venting and recovery procedure, if necessary.

5. Open drain valve(s) located on the underside of the separator and drain the oil.
6. Drain oil filter, strainers, and oil cooler, if applicable.

7. Remove and install new oil filter element.
8. Remove, clean, and reinstall strainer elements in strainers.
9. Evacuate unit to 29.88" Hg (1000 microns).
10. Open suction service valve and pressurize the unit to system suction pressure. Close the suction valve and leak test.
11. Add oil by attaching a suitable pressure-type hose to the oil drain valve located on top of the separator. Using a pressure-type oil pump and recommended Frick oil, open the drain valve and fill the separator until oil level is midway in the top sight glass. **NOTE: Evacuation of the oil separator will assist the flow of oil into the unit. Also, fill slowly because oil will fill up in the separator faster than it shows in the sight glass.** See Oil Charge section.
12. Open discharge and liquid injection service valves.
13. Close disconnect switch for compressor motor starter.
14. Start the unit.

SUCTION STRAINER CLEANING PROCEDURE

1. Open disconnect switch.
2. Isolate the package by closing all package valves to the system. Tag all closed valves.



Open any solenoid valves or other valves that may trap liquid between the isolation valves and other package valves to prevent injury or damage to components.

3. With liquid injection, close the manual hand valve upstream of YY7 and manually open YY7 by turning in the manual opening stem (clockwise viewed from below valve).



Failure to follow this procedure will damage valve YY7.

4. **SLOWLY** vent the separator to low-side system pressure using the suction check valve bypass. **NOTE: Recover or transfer all refrigerant vapor, in accordance with local ordinances, before opening to atmosphere.** The separator **MUST** be equalized to atmospheric pressure.



Oil entrained refrigerant may vaporize, causing a separator pressure increase. Repeat transfer and recovery procedure, if necessary.

5. Remove cover plate.
6. Remove strainer.
7. Clean strainer.
8. Reinstall the strainer in the proper direction (outboard end is marked) and replace the gasket.



If the strainer is installed backwards, it will be damaged.

9. Pressurize and leak test. Evacuate unit to 29.88" Hg (1000 microns).
10. First, reset solenoid valves to automatic position then open all valves previously closed. Remove tags. Close disconnect switches for compressor. Start unit.

DEMAND PUMP DISASSEMBLY



BEFORE OPENING ANY VIKING PUMP LIQUID CHAMBER (PUMPING CHAMBER, RESERVOIR, JACKET, ETC.) ENSURE:

JACKET, ETC.) ENSURE:

1. THAT ANY PRESSURE IN THE CHAMBER HAS BEEN COMPLETELY VENTED THROUGH SUCTION OR DISCHARGE LINES OR OTHER APPROPRIATE OPENINGS OR CONNECTIONS.

2. THAT THE DRIVING MEANS (MOTOR, TURBINE, ENGINE, ETC.) HAS BEEN "LOCKED OUT" OR MADE NONOPERATIONAL SO THAT IT CANNOT BE STARTED WHILE WORK IS BEING DONE ON THE PUMP.

FAILURE TO FOLLOW ABOVE LISTED PRECAUTIONARY MEASURES MAY RESULT IN SERIOUS INJURY OR DEATH.

1. Mark head and casing before disassembly to ensure proper reassembly. The idler pin, which is offset in the pump head, must be positioned up and equal distance between port connections to allow for proper flow of liquid through the pump.

2. Remove the head capscrews.

3. Tilt top of head back when removing to prevent idler from falling off idler pin.

4. Remove idler and bushing assembly. If idler bushing needs replacing, see **INSTALLATION OF CARBON GRAPHITE BUSHINGS**.

5. Insert a brass bar or piece of hardwood in the port opening and between the rotor teeth to keep the shaft from turning. Turn the locknut counterclockwise and remove locknut. See Figure 27 or 28.

6. Loosen the two setscrews in the face of bearing housing and turn the thrust bearing assembly counterclockwise and remove from casing. See Figure 27 or 28.

7. **GG, HJ, HL:** Remove the snap ring from the shaft. See Figure 27. **AS, AK, AL:** Remove the bearing spacer from the shaft. See Figure 28.

8. Remove the brass bar or piece of hardwood from the port opening.

9. The rotor and shaft can now be removed by tapping on the end of the shaft with a lead hammer or, if using a regular hammer, use a piece of hardwood between the shaft and hammer. The rotary member of the seal will come out with the rotor and shaft.

10. **AS, AK, AL:** Remove the bearing retainer washer. The washer may have stayed with rotor and shaft when removed or is against ball bearing. See Figure 28.

11. Remove the mechanical seal rotary member and spring from the rotor and shaft assembly.

12. **GG, HJ, HL:** Remove inner snap ring and single-row ball bearing from the casing.

AS, AK, AL: Remove single-row ball bearing from casing.

13. Remove seal seat or stationary part of seal from casing.

14. Disassemble the thrust-bearing assembly.

GG, HJ, HL: Remove outer snap ring from the bearing housing and remove the ball bearing. See Figure 27.

AS, AK, AL: Loosen the two set screws in flange outside diameter. Rotate end cap and lip seal counterclockwise and remove. Remove the ball bearing. See Figure 28.

The casing should be examined for wear, particularly in the area between ports. All parts should be checked for wear before the pump is put together.

When making major repairs, such as replacing a rotor and shaft, it is advisable to also install a new mechanical seal, head and idler pin, idler, and bushing. See **INSTALLATION OF CARBON-GRAPHITE BUSHINGS**.

Clean all parts thoroughly and examine for wear or damage. Check lip seals, ball bearings, bushing, and idler pin and replace if necessary. Check all other parts for nicks, burrs, excessive wear and replace if necessary.

Wash bearings in clean solvent. Blow out bearings with compressed air. **DO NOT allow bearings to spin**; turn them slowly by hand. Spinning bearings will damage the race and balls. Make sure bearings are clean, then lubricate with refrigeration oil and check for roughness. Roughness can be determined by turning outer race by hand. Replace the bearings if they have roughness.

Be sure shaft is free from nicks, burrs and foreign particles that might damage mechanical seal. Scratches on shaft in

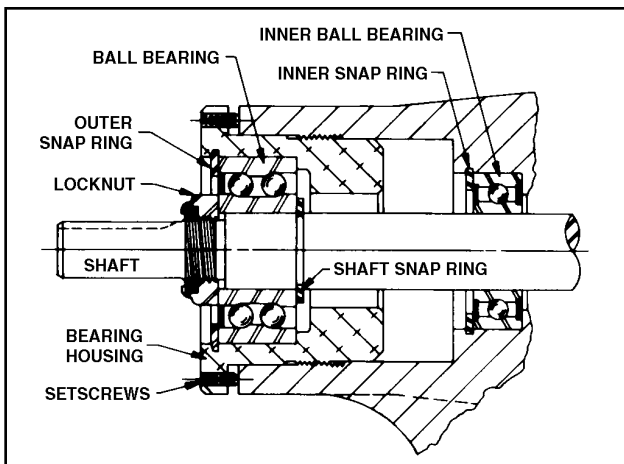

Figure 27 - Thrust-Bearing assembly (GG, HJ, HL)

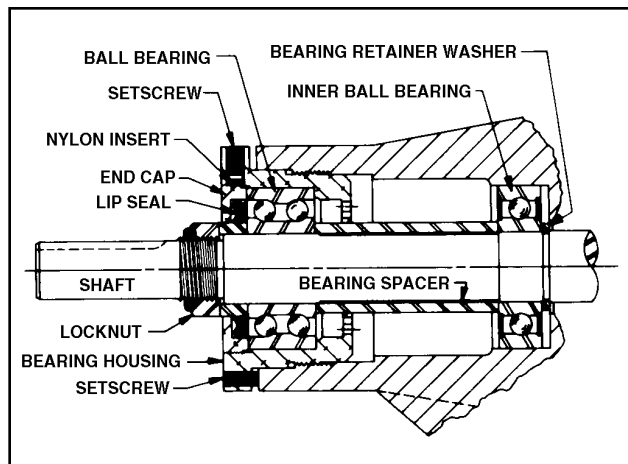

Figure 28 - Thrust-Bearing assembly (AS, AK, AL)

seal area will provide leakage paths under mechanical seal. Use fine emery cloth to remove scratches or sharp edges.

DEMAND PUMP ASSEMBLY

Assembly Notes On Standard Mechanical Seal (Synthetic Rubber Bellows Type)

NOTE: Read carefully before reassembling pump

The seal used in this pump is simple to install and good performance will result if care is taken during installation. The principle of a mechanical seal is contact between the rotary and stationary members. These parts are lapped to a high finish and their sealing effectiveness depends on complete contact.

Prior to installing the rotary portion of the mechanical seal, prepare and organize the rotor shaft, head and idler assemblies, and appropriate gaskets for quick assembly

Once the rotary portion of the mechanical seal is installed on the rotor shaft, it is necessary to assemble parts as quickly as possible to ensure that the seal does not stick to the shaft in the wrong axial position. The seal will stick to the shaft after several minutes setting time.

Never touch sealing faces with anything except clean hands or clean cloth. Minute particles can scratch the seal faces and cause leakage.

1. Coat the idler pin with refrigeration oil and place idler and bushing on idler pin in the head. If replacing a carbon-graphite bushing, refer to "**Installation of Carbon Graphite Bushings**".

2. Clean rotor hub and casing seal housing bore. Make sure both are free from dirt and grit. Coat outer diameter of seal seat and inner diameter of seal housing bore with refrigeration oil.

3. Start seal seat in seal housing bore. If force is necessary, protect seal face with a clean cardboard disc and gently tap it in place with a piece of wood. Be sure seal seat is completely seated in the bore.

4. Place tapered installation sleeve on shaft. Refer to Figure 29. Sleeve is furnished with GG, AS, AK, and AL replacement mechanical seals. Coat rotor shaft, tapered installation sleeve, and inner diameter of mechanical seal rotary member with a generous amount of refrigeration oil. Petrolatum may be used but grease is not recommended.

5. Place seal spring on the shaft against the rotor hub. Refer to Figure 30.

6. Slide rotary member, with lapped contact surface facing away from the spring, over installation sleeve on shaft until just contacting the spring. Do not compress the spring. Remove the installation sleeve.

7. Coat the rotor shaft with refrigeration oil. Install the rotor and shaft into the casing, slowly pushing until the ends of the rotor teeth are just below the face of the casing. **Take care not to damage the seal seat.**

8. Leave the rotor in this position. Withdrawal of rotor and shaft may displace the carbon seal rotating face and result in damage to the seal.

9. Place O-ring gasket on the head and install head and idler assembly on pump. Pump head and casing were marked before disassembly to ensure proper reassembly. If not, be sure the idler pin, which is offset in pump head, is positioned up and equal distance between port connections to allow for proper flow of liquid through the pump.

10. Tighten the head capscrews evenly.

11. If the pump was equipped with a relief valve and was removed during disassembly, install on the head with new O-Rings or gaskets. The relief valve adjusting screw cap must always point towards the suction port.

12. In 2005, the use of single seal bearings were phased out. Pumps now use "Sealed for Life" bearings that have seals on both sides. The new bearings can be installed either side first and do not need to be packed with grease. For older models with single seal bearings, pack the inner ball bearing with multi-purpose grease, NLGI #2.

GG, HJ, HL: Drive the bearing into the bore. Tap the inner race with a brass bar and lead hammer to position bearing. Install the inner snap ring.

AS, AK, AL: Install the bearing retainer washer over the shaft before installing the ball bearing. Install the ball bearing in the casing with sealed side towards head end of the pump. Drive the bearing into the bore. Tap the inner race with a brass bar and lead hammer to position the bearing.

13. GG, HJ, HL: Install the shaft snap ring in groove in the shaft. See Figure 27.

AS, AK, AL: Install the bearing spacer over the shaft and against the single row ball bearing. See Figure 28.

14. Pack the lubrication chamber between the inner ball bearing and double row ball bearing in the thrust bearing assembly approximately one-half full of multi-purpose grease, NLGI #2. The thrust bearing assembly will take the remaining space. See Figures 27 and 28.

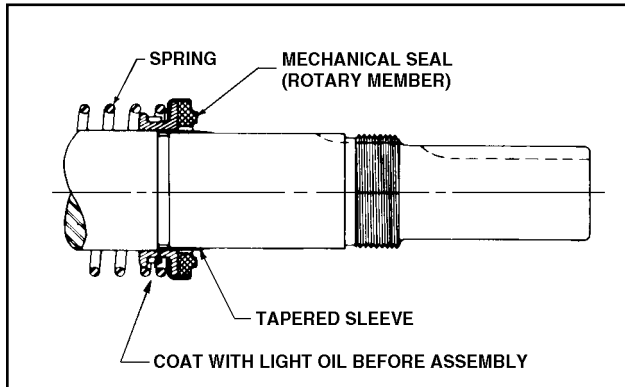

Figure 29

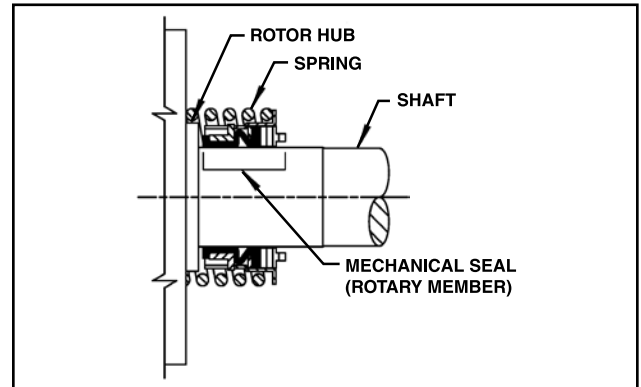

Figure 30

15. Pack the double row ball bearing with multi-purpose grease, NLGI #2.

GG, HJ, HL: Install the ball bearing into the bearing housing with shield side toward the coupling end of the shaft. See Figure 27. Install the snap ring into bearing housing to retain ball bearing. This snap ring has a tapered edge to fit tapered groove in bearing housing. The tapered edge is located away from the ball bearing.

AS, AK, AL: Install the ball bearing into the bearing housing. Install the lip seal in the bearing housing end cap. The lip should face towards the end of the shaft. Put the bearing spacer collar in the lip seal and install in the bearing housing and tighten the set screws securely. See Figure 28.

16. Insert a brass bar or piece of hardwood through the port opening between the rotor teeth to keep the shaft from turning.

17. Start the thrust bearing assembly into casing. Turn by hand until tight. This forces the rotor against the head. Replace and tighten the locknut or shaft.

18. Remove the brass bar or hardwood from port opening.

19. Adjust pump end clearance, refer to “Thrust Bearing Adjustment”.

⚠ DANGER BEFORE STARTING PUMP, ENSURE THAT ALL DRIVE EQUIPMENT GUARDS ARE IN PLACE. FAILURE TO PROPERLY MOUNT GUARDS MAY RESULT IN SERIOUS INJURY OR DEATH.

THRUST BEARING ADJUSTMENT

Loosen two screws in face of thrust-bearing assembly. See Figures 27 and 28.

If shaft cannot be rotated freely, turn thrust-bearing assembly counterclockwise until shaft can be turned easily.

1. While turning rotor shaft, rotate thrust-bearing assembly clockwise until noticeable drag occurs. This is zero end clearance.
2. Mark position of bearing housing with respect to the casing.
3. Rotate thrust-bearing assembly counterclockwise the distance listed below as measured on outside of bearing housing.
4. Tighten two setscrews in face of bearing housing after adjustment is made to secure thrust-bearing assembly position.

For viscosities above 2500 SSU, add additional end clearance (0.004" for GG, HJ and HL size pumps and 0.005" for AS, AK and AL size pumps).

Pump Size	Distance (in.) on O.D. of Bearing Housing	End Clearance (in.)
GG	7/16	.003
HJ, HL	9/16	.003
AS, AK, AL	1/2	.003

INSTALLATION OF CARBON GRAPHITE BUSHINGS

When installing carbon graphite bushings, extreme care must be taken to prevent breaking. Carbon graphite is a brittle material and easily cracked. If cracked, the bushing will quickly disintegrate. Using a lubricant and adding a chamfer on the bushing and the mating part will help in installation. The additional precautions listed below must be followed for proper installation:

1. A press must be used for installation.
2. Be certain bushing is started straight.
3. Do not stop pressing operation until bushing is in proper position. Starting and stopping will result in a cracked bushing.
4. Check bushing for cracks after installation.

TROUBLESHOOTING THE DEMAND PUMP

⚠ DANGER BEFORE OPENING ANY PUMP LIQUID CHAMBER (PUMPING CHAMBER, RESERVOIR, JACKET ETC.) ENSURE:

1. THAT ANY PRESSURE IN CHAMBER HAS BEEN COMPLETELY VENTED THROUGH SUCTION OR DISCHARGE LINES OR OTHER APPROPRIATE OPENINGS OR CONNECTIONS.
2. THAT THE DRIVING MEANS (MOTOR, TURBINE, ENGINE, ETC.) HAS BEEN “LOCKED OUT” OR MADE NONOPERATIONAL SO THAT IT CANNOT BE STARTED WHILE WORK IS BEING DONE ON PUMP.

FAILURE TO FOLLOW ABOVE LISTED PRECAUTIONARY MEASURES MAY RESULT IN SERIOUS INJURY OR DEATH.

Mark valve and head before disassembly to ensure proper reassembly.

If trouble does develop, one of the first steps toward finding the difficulty is to *install a vacuum gauge in the suction port and a pressure gauge in the discharge port*. Readings on these gauges often will give a clue as to where to start looking for the trouble.

Vacuum Gauge—Suction Port

1. High reading would indicate:
 - a. Suction line blocked - foot valve stuck, gate valve closed, strainer plugged.
 - b. Liquid too viscous to flow through the piping.
 - c. Lift too high.
 - d. Line too small.
2. Low reading would indicate -
 - a. Air leak in suction line.
 - b. End of pipe not in liquid.
 - c. Pump is worn.
 - d. Pump is dry - should be primed.
3. Fluttering, jumping, or erratic reading:
 - a. Liquid vaporizing.
 - b. Liquid coming to pump in slugs - possibly an air leak or insufficient liquid above the end of the suction pipe.
 - c. Vibrating from cavitation, misalignment, or damaged parts.

Pressure Gauge - Discharge Port

1. High reading would indicate:
 - a. High viscosity and small and/or long discharge line.
 - b. Gate valve partially closed.
 - c. Filter plugged.
 - d. Vertical head did not consider a high specific gravity liquid.
 - e. Line partially plugged from buildup on inside of pipe.
 - f. Liquid in pipe not up to temperature.
 - g. Liquid in pipe has undergone a chemical reaction and has solidified.
 - h. Relief valve set too high.
2. Low reading would indicate:
 - a. Relief valve set too low
 - b. Relief valve poppet not seating properly.
 - c. Too much extra clearance.
 - d. Pump worn.
3. Fluttering, jumping, or erratic reading:
 - a. Cavitation.
 - b. Liquid coming to pump in slugs.
 - c. Air leak in suction line.
 - d. Vibrating from misalignment or mechanical problems.

Some of the following may also help pinpoint the problem:

1. Pump does not pump.
 - a. Lost its prime - air leak, low level in tank.
 - b. Rotating in wrong direction.
 - c. Motor does not come up to speed.
 - d. Suction and discharge valves not open.
 - e. Strainer clogged.
 - f. Relief valve set too low, relief valve poppet stuck open.
 - g. Pump worn out.
 - h. Any changes in the liquid system, or operation that would help explain the trouble, e.g. new source of supply, added more lines, inexperienced operators, etc.
 - i. Tighten end clearance.
 - j. Head position incorrect.
2. Pump starts, then loses its prime.
 - a. Low level in tank.
 - b. Liquid vaporizing in the suction line.
 - c. Air leaks or air pockets in the suction line; leaking air through packing or mechanical seal.
 - d. Worn out.
3. Pump is noisy
 - a. Pump is being starved (heavy liquid cannot get to pump fast enough). Increase suction pipe size or reduce length.
 - b. Pump is cavitating (liquid vaporizing in the suction line). Increase suction pipe size or reduce length; if pump is above the liquid, raise the liquid level closer to the pump; if the liquid is above the pump, increase the head of liquid.
 - c. Check alignment.
 - d. May have a bent shaft or rotor tooth. Straighten or replace.
 - e. May be a foreign object trying to get into the pump through the suction port.
4. Pump not up to capacity
 - a. Starving or cavitating - increase suction pipe size or reduce length.
 - b. Strainer partially clogged - clean.
 - c. Air leak in suction piping or along pump shaft.
 - d. Running too slowly - is motor the correct speed and is it wired up correctly
 - e. Relief valve set too low or stuck open.
 - f. Pump worn out.

- g. Tighten end clearance.
- h. Head position incorrect.
5. Pump takes too much power.
 - a. Running too fast - is correct motor speed, reducer ratio, sheave size, etc. being used.
 - b. Liquid more viscous than unit sized to handle - heat the liquid, increase the pipe size, slow the pump down, or get a bigger motor.
 - c. Discharge pressure higher than calculated - check with pressure gauge. Increase size or reduce length of pipe, reduce speed (capacity), or get bigger motor.
 - d. Pump misaligned.
 - e. Extra clearance on pumping elements may not be sufficient for operating conditions. Check parts for evidence of drag or contact in pump and increase clearance where necessary
6. Rapid Wear.

Examination of a pump that has gradually lost its ability to deliver capacity or pressure would show a smooth wear pattern on all parts. Rapid wear shows up as heavy grooving, galling, twisting, breaking, or similar severe signs of trouble.

RECOMMENDED MAINTENANCE PROGRAM

In order to obtain maximum compressor unit performance and ensure reliable operation, a regular maintenance program should be followed (see Maintenance Schedule):

The compressor unit should be checked daily for leaks, abnormal vibration, noise, and proper operation. A daily log should also be maintained. There should be a continued monitoring of oil quality and oil analysis testing. In addition, an analysis of the unit's vibration should be made periodically.

VIBRATION ANALYSIS

Periodic vibration analysis can be useful in detecting bearing wear and other mechanical failures. If vibration analysis is used as a part of your preventive maintenance program, take the following guidelines into consideration.

1. Always take vibration readings from exactly the same places, at exactly the same percent of load.
2. Use vibration readings taken from the new unit at start-up as the base line reference.
3. Evaluate vibration readings carefully as the instrument range and function used can vary. Findings can be easily misinterpreted.
4. Vibration readings can be influenced by other equipment operating in the vicinity or connected to the same piping as the unit. For additional information, request Frick® publication E70-902 IB.

OIL QUALITY and ANALYSIS

High quality refrigeration oil is necessary to ensure compressor longevity and reliability. Oil quality will rapidly deteriorate in refrigeration systems containing moisture and air or other contaminants. In order to ensure the quality of the refrigeration oil in the compressor unit.



DO NOT MIX OILS of different brands, manufacturers, or types. Mixing of oils may cause excessive oil foaming, nuisance oil level cutouts, oil pressure loss, gas or oil leakage and catastrophic compressor failure.

NOTE: The Frick oil charge shipped with the unit is the best suited lubricant for the conditions specified at the

time of purchase. If there is any doubt due to the refrigerant, operating pressures, or temperatures, refer to Frick Oil publication 160-802 SPC for guidance.

1. Only use Frick® oil filter elements or warranty claim may be denied.

2. Participate in a regular, periodic oil analysis program to maintain oil and system integrity. Oil Analysis Kit part number: 333Q0001853.

3. Oil samples for analysis should be taken after the oil filter. A ¼" purge valve is provided between the filter and compressor.

MAINTENANCE SCHEDULE

This schedule should be followed to ensure trouble-free operation of the compressor unit.

MAINTENANCE	FREQUENCY OR HOURS OF OPERATION (MAXIMUM)																						
	200	1000	5000	8000	10,000	15,000	20,000	25,000	30,000	35,000	40,000	45,000	50,000	55,000	60,000	65,000	70,000	75,000	80,000	85,000	90,000	95,000	
Change Oil	As Directed By Oil Analysis																						
Oil Analysis	■	Every 6 Months																					
Replace Filters	■	■	■	■	■	■	■	■	■	■	■	■	■	■	■	■	■	■	■	■	■	■	■
Clean Oil Strainers	■	■	■	■	■	■	■	■	■	■	■	■	■	■	■	■	■	■	■	■	■	■	■
Clean Liquid Strainers	■	■	■	■	■	■	■	■	■	■	■	■	■	■	■	■	■	■	■	■	■	■	■
Replace Coalescers							■						■									■	
Check and Clean Suction Strainer	■	■	■	■	■	■	■	■	■	■	■	■	■	■	■	■	■	■	■	■	■	■	■
Check Coupling (a)	■	Annually Regardless of Operating Hours																					
Suction & Disch Flange Bolts (d)	■	■	■	■	■	■	■	■	■	■	■	■	■	■	■	■	■	■	■	■	■	■	■
VFD Units Check Skip Freq. (f)	■	■	■	■	■	■	■	■	■	■	■	■	■	■	■	■	■	■	■	■	■	■	■
Check Electrical Connections (b)	■	■	■	■	■	■	■	■	■	■	■	■	■	■	■	■	■	■	■	■	■	■	■
Check Sensor Calibration (c)	■	■	■	■	■	■	■	■	■	■	■	■	■	■	■	■	■	■	■	■	■	■	■
Vibration Analysis (e)	■	Every 6 Months, More Frequently If Levels Increase																					
Replace Shaft Seal	When Leak Rate Exceeds 7 - 8 Drops Per Minute																						

- a. Check bolts, shim packs, center inserts, keys, and all bolt torques.
- b. Check and torque all terminals in the processor and starter panel per the specification posted in the enclosure.
- c. Check calibration of Slide Valve, Slide Stop, pressures and temperatures.
- d. Verify tightness of bolts on suction and discharge flanges. See table below for torque requirements.
- e. Vibration measurement must be carried out continuously to obtain optimum preventative control on bearings. If not continuously controlled, then every 6 months, more frequently if levels increase.
- f. Units with variable speed drives - check for excess vibration and skip frequencies any time unit operating conditions change.

RXF Model	Compressor Model	Motor Flange to Compressor Tunnel ⁽¹⁾		Compressor Flange to Separator Flange ⁽²⁾	
		Bolt Size (in.)	Torque (ft-lb)	Bolt Size	Torque (ft-lb)
12, 15, 19	XJF 95S,M,L	1/2 or 5/8	58	M20 X 2.5	107
24, 30, 39, 50	XJF 120S,M,L,S	1/2 or 5/8	58	M20 X 2.5	150
58, 68, 85, 101	XJF 151A,M,L,N	5/8 or 3/4	144	M22 X 2.5	167

1. Based on metal to metal contact.
2. Based on: Gaskets: Garlock® Blue-Gard® 3300; Bolts: class 8.8 or stronger hex head bolts, lightly oiled and clean

LUBRICATION SCHEDULE / INSTRUCTIONS

SYNC. RPM	FRAME SERIES	SERVICE CYCLE* - BALL BEARING**	
		8 HR/DAY OPERATION	24 HR/DAY OPERATION
3600	360-5800	150 DAYS (1200 HRS)	50 DAYS (1200 HRS)
1800	360	390 DAYS (3120 HRS)	130 DAYS (3120 HRS)
	400-440	270 DAYS (2160 HRS)	90 DAYS (2160 HRS)
	5000-5800	210 DAYS (1680 HRS)	70 DAYS (1680 HRS)
1200	360-440	390 DAYS (3120 HRS)	130 DAYS (3120 HRS)
	5000-5800	270 DAYS (2160 HRS)	90 DAYS (2160 HRS)

- LUBRICATE BEARINGS WITH POWER IN THE OFF CONDITION.
- CLEAR AND CLEAN THE GREASE FITTINGS AND SURROUNDING AREA.
- REMOVE THE PIPE PLUG FROM THE VENTING PORT OPPOSITE THE GREASE FITTING.
- USING A LOW PRESSURE GREASE GUN APPLY 1 OZ. (30 GRAMS) OF GREASE AT EACH FITTING. DO NOT OVERGREASE.
- WITH THE VENT PORTS OPEN, OPERATE THE MOTOR FOR A MINIMUM OF 15 MINUTES AND UNTIL ANY GREASE FLOW HAS CEASED AT THE VENTING PORTS.
- REMOVE POWER.
- REPLACE THE VENT PIPE PLUGS.
- REPLACE ANY AND ALL GUARDS AND COVERS THAT MAY HAVE BEEN REMOVED TO ACCESS THE MOTOR.

* LUBRICATION SCHEDULE FOR SEVERE SERVICE (VIBRATION, SHOCK AND/OR ENVIRONMENTAL EXTREME) = 1/3 OF THE ABOVE INTERVALS.

** LUBRICATION SCHEDULE FOR ROLLER BEARINGS = 1/3 OF ABOVE INTERVALS.

THE FACTORY INSTALLED, RECOMMENDED LUBRICANT IS LISTED ON THE MOTOR DATA PLATE. THIS IS A POLYUREA GREASE, AS ARE THE PRODUCTS LISTED BELOW. THE INTRODUCTION OF LUBRICANTS OF ALTERNATE CHEMICAL MAKEUP IS NOT RECOMMENDED AND WILL CAUSE MECHANICAL FAILURE WITHOUT THE COMPLETE PURGE OF THE FACTORY PRODUCT FROM THE BEARING AND RESERVOIR. WHEREVER POSSIBLE, APPLY THE POLYUREA PRODUCT.

CHEVRON OIL CO. - SRI#2 MOBILE POLYUREX EM

Figure 31

MOTOR BEARINGS



Lubricate motor bearings properly before start-up. Maintain subsequent lubrication as recommended

by the motor manufacturer. See Figure 31.

OPERATING LOG

The use of an operating log, as shown in this manual (see Table of Contents...FORMS), permits thorough analysis of the operation of a refrigeration system by those responsible for its maintenance and servicing. Continual recording of gauge pressures, temperatures, and other pertinent information enables the observer and serviceman to be constantly familiar with the operation of the system and to recognize immediately any deviations from normal operating conditions. It is recommended that readings be taken at least every four hours.

TROUBLESHOOTING GUIDE

Successful problem solving requires an organized approach to define the problem, identify the cause, and make the proper correction. Sometimes it is possible that two relatively obvious problems combine to provide a set of symptoms that can mislead the troubleshooter. Be aware of this possibility and avoid solving the "wrong problem".

ABNORMAL OPERATION ANALYSIS and CORRECTION

Four logical steps are required to analyze an operational problem effectively and make the necessary corrections:

1. Define the problem and its limits.
2. Identify all possible causes.
3. Test each cause until the source of the problem is found.
4. Make the necessary corrections.

The first step in effective problem solving is to define the limits of the problem. If, for example, the compressor periodically experiences high oil temperatures, do not rely on this observation alone to help identify the problem. On the basis of this information, the apparent corrective measure would appear to be a readjustment of the liquid injection system. Lowering the equalizing pressure on the thermal expansion valve would increase the refrigerant feed and the oil temperature should drop.

If the high oil temperature was the result of high suction superheat, however, and not just a matter of improper liquid injection adjustment, increasing the liquid feed could lead to other problems. Under low load conditions the liquid injection system may have a tendency to overfeed. The high suction superheat condition, moreover, may only be temporary. When system conditions return to normal, the unit's liquid injection will overfeed and oil temperature will drop. In solving the wrong problem a new problem was created.

The following list of abnormal system conditions can cause abnormal operation of the **RXF** compressor unit:

1. Insufficient or excessive refrigeration load.
2. Excessively high suction pressure.
3. Excessively high suction superheat.
4. Excessively high discharge pressure.
5. Inadequate refrigerant charge or low receiver level.
6. Excessively high or low temperature coolant to the oil cooler.
7. Liquid return from system (carryover).
8. Refrigerant underfeed or overfeed to evaporators.
9. Blocked tubes or plates in water-cooled oil cooler from high mineral content of water.
10. Insufficient evaporator or condenser sizing.

PRESSURE TRANSDUCER CONVERSION DATA								
Sensor Voltage	100 psi		200 psi		300 psi		500 psi	
	Range - PSIG*		Range - PSIG*		Range - PSIG*		Range - PSIG*	
	low	high	low	high	low	high	low	high
1.0	29.92"	19.74"	29.92"	9.57"	29.92"	7.0"	29.92"	4.10
1.1	29.92"	14.65"	29.92"	0.30	29.92"	4.10	29.92"	16.60
1.2	29.92"	9.57"	29.92"	5.30	22.3"	11.60	17.1"	29.10
1.3	24.83"	4.48"	19.74"	10.30	7.0"	19.10	4.10	41.60
1.4	19.74"	0.30	9.57"	15.30	4.10	26.60	16.60	54.10
1.5	14.65"	2.80	0.30	20.30	11.60	34.10	29.10	66.60
1.6	9.57"	5.30	5.30	25.30	19.10	41.60	41.60	79.10
1.7	4.48"	7.8	10.3	30.30	26.60	49.10	54.10	91.60
1.8	0.30	10.30	15.30	35.30	34.10	56.60	66.60	104.10
1.9	2.80	12.80	20.30	40.30	41.60	64.10	79.10	116.60
2.0	5.30	15.30	25.30	45.30	49.10	71.60	91.60	129.10
2.1	7.80	17.80	30.30	50.30	56.60	79.10	104.10	141.60
2.2	10.30	20.30	35.30	55.30	64.10	86.60	116.60	154.10
2.3	12.80	22.80	40.30	60.30	71.60	94.10	129.10	166.60
2.4	15.30	25.30	45.30	65.30	79.10	101.60	141.60	179.10
2.5	17.80	27.80	50.30	70.30	86.60	109.10	154.10	191.60
2.6	20.30	30.30	55.30	75.30	94.10	116.60	166.60	204.10
2.7	22.80	32.80	60.30	80.30	101.60	124.10	179.10	216.60
2.8	25.30	35.30	65.30	85.30	109.10	131.60	191.60	229.10
2.9	27.80	37.80	70.30	90.30	116.60	139.10	204.10	241.60
3.0	30.30	40.30	75.30	95.30	124.10	146.60	216.60	254.10
3.1	32.80	42.80	80.30	100.30	131.60	154.10	229.10	266.60
3.2	35.30	45.30	85.30	105.30	139.10	161.60	241.60	279.10
3.3	37.80	47.80	90.30	110.30	146.60	169.10	254.10	291.60
3.4	40.30	50.30	95.30	115.30	154.10	176.60	266.60	304.10
3.5	42.80	52.80	100.30	120.30	161.60	184.10	279.10	316.60
3.6	45.30	55.30	105.30	125.30	169.10	191.60	291.60	329.10
3.7	47.80	57.80	110.30	130.30	176.60	199.10	304.10	341.60
3.8	50.30	60.30	115.30	135.30	184.10	206.60	316.60	354.10
3.9	52.80	62.80	120.30	140.30	191.60	214.10	329.10	366.60
4.0	55.30	65.30	125.30	145.30	199.10	221.60	341.60	379.10
4.1	57.80	67.80	130.30	150.30	206.60	229.10	354.10	391.60
4.2	60.30	70.30	135.30	155.30	214.10	236.60	366.60	404.10
4.3	62.80	72.80	140.30	160.30	221.60	244.10	379.10	416.60
4.4	65.30	75.30	145.30	165.30	229.10	251.60	391.60	429.10
4.5	67.80	77.80	150.30	170.30	236.60	259.10	404.10	441.60
4.6	70.30	80.30	155.30	175.30	244.10	266.60	416.60	454.10
4.7	72.80	82.80	160.30	180.30	251.60	274.10	429.10	466.60
4.8	75.30	85.30	165.30	185.30	259.10	281.60	441.60	479.10
4.9	77.80	87.80	170.30	190.30	266.60	289.10	454.10	491.60
5.0	80.30	90.30	175.30	195.30	274.10	296.60	466.60	504.10
At 0 psig	1.388 V	1.788 V	1.094 V	1.494 V	1.046 V	1.346 V	0.968 V	1.268 V

* Below 0 PSIG measured in inches of mercury.

11. Incorrect refrigerant line sizing.
12. Improper system piping.
13. Problems in electrical service to compressor unit.
14. Air and moisture present in the system.

Make a list of all deviations from normal plant operation and normal compressor unit operation. Delete any items which do not relate to the symptom and separately list those items that might relate to the symptom. Use the list as a guide to further investigate the problem.

The second step in problem solving is to decide which items on the list are possible causes and which items are additional symptoms. High discharge temperature and high oil temperature readings may both be symptoms of a problem and not casually related. High suction superheat or a low receiver level, however, could cause both symptoms.

The third step is to identify the most likely cause and take action to correct the problem. If the symptoms are not relieved,

move to the next item on the list and repeat the procedure until you have identified the cause of the problem. Once the cause has been identified and confirmed, make the necessary corrections.

PRESSURE TRANSDUCERS - TESTING

Test Procedure:

1. Shut compressor down and allow pressures to equalize.
2. Isolate suction transducer (PE-4) from unit and depressurize. **NOTE: Recover or transfer all refrigerant vapor, in accordance with local ordinances, before opening to atmosphere.**
3. Measure the DC voltage of (PE-4) on connector (P6A) (terminals 2 and 3) on the analog board with a digital volt-meter.
4. The voltage reading should be between 1.48 VDC and 1.72 VDC at standard atmospheric pressure (14.7 PSIA or 0 PSIG). When checking transducers at higher elevations,

an allowance in the readings must be made by subtracting approximately 0.02 VDC per 1000 feet of elevation above sea level. Barometric pressure can generally be ignored but in extreme cases may be compensated for by adding/subtracting 0.002 VDC for each 0.1 inch of barometric pressure (adjusted to sea level) above/below 0 PSIG. Therefore, if (PE-4) is measured at 5000 feet elevation under relatively normal weather conditions, the output voltage should differ by 0.10 VDC to read between 1.38 VDC and 1.62 VDC.

5. Subtract 1 from the voltage.
6. Multiply by 25.
7. This result is the absolute suction pressure (PSIA). Subtract 14.7 to obtain PSIG which the Operating display will indicate.
8. Isolate the oil pressure transducers (PE-1 & PE-2) from the package and depressurize. **NOTE: Recover or transfer all refrigerant vapor, in accordance with local ordinances, before opening to atmosphere.**
9. Measure the voltage of (PE-1 & PE-2) on connector (P5A) (terminals 5 and 6) on the analog board.
10. The voltage reading should be between 1.1 VDC and 1.29 VDC at standard atmospheric pressure. (PE-1 & PE-2) and (PE-3) have a span of 500 PSI as compared to (PE-4) with a span of 200 PSI. Therefore, atmospheric pressure changes have a lesser effect which is 0.0067 VDC per 1000 feet of elevation and 0.00067 VDC per 0.1 inch Hg barometric deviation.
11. Subtract 1.2 from the voltage.
12. Multiply by 75, the result will be PSIG.
13. Since the discharge pressure (PE-3) cannot be closed off from its sensing point (code requirements), remove all transducers from atmosphere and open them to their sensing points so all transducers can equalize to separator pressure.
14. Measure the voltage of (PE-3) on connector (P5B) (terminals 5 and 6) on the analog board.
15. Test complete.

PRESSURE TRANSDUCERS REPLACEMENT

1. Shut off control power.
2. Close the applicable transducer isolation valve. **NOTE: To change the discharge pressure transducer (PE-3), it will be necessary to depressurize the entire compressor package. Follow "General Instructions For Replacing Compressor Unit Components" section before going to step 3.**
3. Remove DIN connector screw, then remove DIN connector from the transducer.

TRANSDUCER	CONNECTION
Suction Pressure	PE-4
Discharge Pressure	PE-3
Oil Pressure	PE-1 & PE-2

4. Unscrew the transducer using a wrench on the metal hex at the base of the transducer. **DO NOT ATTEMPT TO LOOSEN OR TIGHTEN TRANSDUCERS BY THEIR TOP CASING.**

5. Install new transducer, reconnect DIN connector, and retighten DIN connector screw.
6. Recalibrate. **NOTE: If replacing older hard-wired transducer, cut cable at back of old transducer and rewire to the Danfoss unit.**
7. Reopen the transducer isolation valve or compressor package isolation valves.
8. Turn on control power.

SLIDE VALVE TRANSMITTER REPLACEMENT - SLIDE STOP

The Slide Valve Transmitter (Figure 32) is located on the right side of the compressor (facing shaft) at the inlet end.

The linear transmitter with hermetic enclosure is based on the inductive measuring principle. It features removable electronics (from the sensor well) eliminating the need to evacuate the compressor for replacement. This type of transmitter is dedicated to volume ratio control and has no user adjustments.

1. Shut off control power.
2. Remove DIN connector plug from transmitter.
3. Loosen set screws.
4. Remove transmitter unit.
5. Install new transmitter unit.
6. Tighten set screws.
7. Apply DIN connector plug to transmitter.
8. Turn on control power.

NOTE: For calibration of the Slide Valve unit, refer to the Analog Calibration instructions in publication S90-020 O.

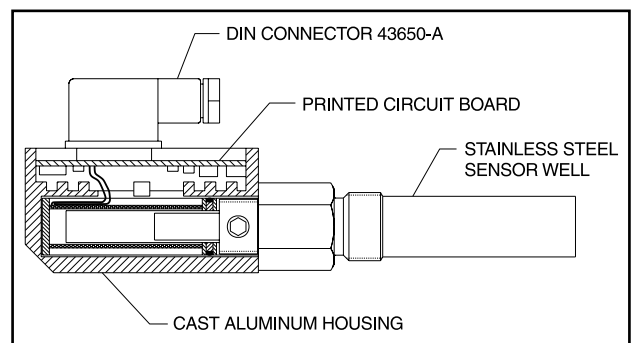

Figure 32 - Slide Valve Transmitter

TEMPERATURE SENSOR REPLACEMENT



This device is static sensitive. Please follow proper ESD procedures when handling.

1. Shut off control power.
2. Remove DIN connector plug from transmitter. See Figure 33.
3. Unscrew knurled ring and remove transmitter unit.

4. Apply thermal compound to new sensor assembly, insert into thermal well, and tighten knurled ring.
5. Apply DIN connector plug to transmitter.
6. Turn on control power.

NOTE: For calibration instructions, refer to Quantum™ LX Operator's Manual 090-020 O, -021 O, -022 O.

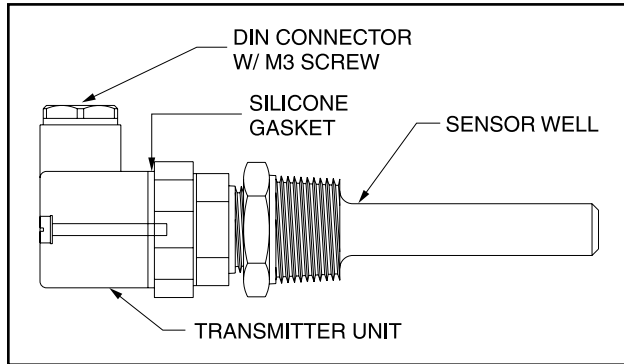

Figure 33 - Temperature Transmitter

OIL LEVEL TRANSMITTER REPLACEMENT

The Oil Level Transmitter is located on the front of the separator near the bottom/center. See Figure 34.

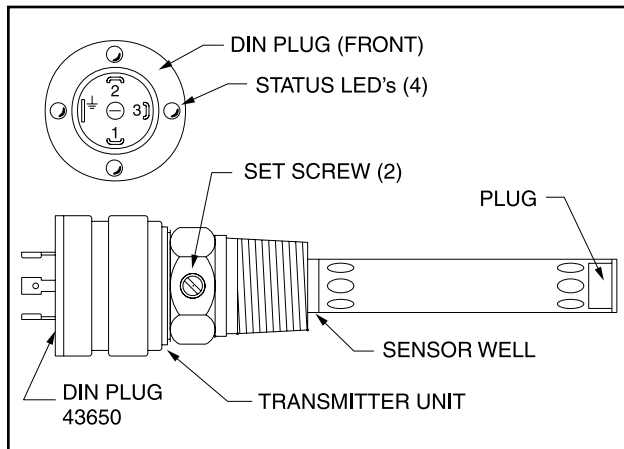

Figure 34 - Oil Level Transmitter

The linear transmitter with hermetic enclosure is based on the capacitive measuring principle. It features removable electronics (from the sensor well) eliminating the need to evacuate the compressor for replacement. This transmitter is dedicated to oil level control and has no user adjustments.



If it is necessary to replace the well, the separator must be purged and the oil drained. Refer to the section "CHANGING OIL."

1. Shut off control power.
2. Remove DIN connector plug from transmitter.
3. Loosen set screws.
4. Remove transmitter unit.
5. Install new transmitter unit.
6. Tighten set screws.
7. Apply DIN connector plug to transmitter.
8. Turn on control power.

TEMPERATURE and/or PRESSURE ADJUSTMENT

All temperature and pressure sensors are factory set. If calibration is required, refer to Analog Calibration for temperature or pressure in QUANTUM™ LX publication 090-021 O or 090-022 O.

BARE COMPRESSOR MOUNTING

Refer to publication S70-660 SM.

TROUBLESHOOTING THE COMPRESSOR

SYMPTON	PROBABLE CAUSES and CORRECTIONS
EXCESSIVE NOISE and VIBRATION	<p>Loose bolts on compressor mounting. Tighten bolts.</p> <p>No oil getting to compressor. Check oil level, oil filter and oil pressure.</p> <p>Bearing damage or excessive wear.</p> <p>Coupling loose on shaft. Tighten coupling. Replace if damaged.</p> <p>Volumizer not adjusted correctly. Readjust.</p> <p>Refrigerant flood-back. Correct system problem.</p>

TROUBLESHOOTING THE OIL SEPARATOR

SYMPTON	PROBABLE CAUSES and CORRECTIONS
GRADUAL OIL LOSS WITH AN OIL LEVEL IN THE COALESCER SECTION SIGHT GLASS	<p>Maintaining too high an oil level. Lower level.</p> <p>Refrigerant carryover or liquid injection overfeeding. Correct operation.</p> <p>Contaminated oil or damaged coalescer filter elements. Replace oil charge and coalescers.</p> <p>Coalescers may be loose. Tighten.</p> <p>Oil return valve closed. Open return valve.</p> <p>Return oil strainer blocked. Clean strainer.</p>
RAPID LOSS WITH NO OIL LEVEL IN THE COALESCER SECTION SIGHT GLASS	<p>Compressor unit suction check valve did not close on shutdown. Repair valve.</p> <p>Bypass open around suction check valve. Close bypass valve.</p> <p>Bypass valve opened too far. Tighten</p> <p>Coalescer filter elements not seated properly. Replace oil charge and coalescers.</p> <p>Oil viscosity too low. Verify correct oil, replace if incorrect.</p> <p>High system CFM. System operating out of design conditions (High suction and Low discharge pressures).</p> <p>Refrigerant flood-back. Correct system problem.</p> <p>Two or more compressors piped to a single economizer vapor port. Verify check valves are in working order.</p>

TROUBLESHOOTING THE LIQUID INJECTION OIL COOLING SYSTEM

SYMPTOM	PROBABLE CAUSES and CORRECTIONS
HIGH OIL TEMPERATURE	<p>Insufficient liquid supply. Check receiver level. Check strainer.</p> <p>Suction superheat too high. Correct system problem.</p> <p>Liquid strainer blocked. Clean strainer.</p> <p>Operating conditions significantly different from design.</p> <p>Malfunctioning Vi Control Solenoids. See function check of the compressor "Volumizer II Vi Control" for further detail.</p> <p>Check motor valve operation and calibration.</p> <p>Check calibration of analog output.</p>
LOW OIL TEMPERATURE	<p>Equalizing pressure too low. Raise pressure.</p> <p>Suction superheat too low or refrigerant flood back on compressor. Correct system problem.</p> <p>Operating conditions significantly different from design.</p> <p>Check motor valve operation and calibration.</p> <p>Check calibration of analog output.</p>
OIL TEMPERATURE FLUCTUATES	<p>System conditions rapidly fluctuate causing liquid injection system to overrespond. Stabilize system operation.</p> <p>Check calibration and operation of motor valve - Adjust P & ID setpoints for analog output.</p>

TROUBLESHOOTING THE HYDRAULIC SYSTEM

SYMPTOM	PROBABLE CAUSES and CORRECTIONS
SLIDE VALVE WILL NOT LOAD OR UNLOAD	<p>Solenoid coil burned out. Replace coil.</p> <p>HV2 needle valve closed. Open valve.</p> <p>Solenoid spool may be stuck or centering spring broken. Free spool or replace spring.</p> <p>Solenoid may be mechanically actuated by inserting a piece of 3/16" rod against armature pin and pushing spool to opposite end. Push "A" side to confirm unload capability. If valve works, problem is electrical.</p> <p>Solenoid valve piston hung in bore or bolt loose. Check piston or tighten bolt.</p>
SLIDE VALVE WILL LOAD BUT WILL NOT UNLOAD	<p>YY1 solenoid coil burned out. Replace coil.</p> <p>Check valve in solenoid valve piston bad. Replace or repair.</p> <p>Dirt inside solenoid valve preventing valve from operating both ways. Clean valve.</p> <p>Solenoid may be mechanically actuated by inserting a piece of 3/16" rod against armature pin and pushing spool to opposite end. Push YY1 valve to confirm unload capability. If valve works, problem is electrical.</p> <p>Slipper seals worn out or damaged. Replace.</p> <p>Check valve in slide valve piston sticking. Remove and clean check valve.</p>
SLIDE VALVE WILL UNLOAD BUT WILL NOT LOAD	<p>YY2 solenoid coil burned out. Replace coil.</p> <p>Dirt inside solenoid valve preventing valve from operating both ways. Clean valve.</p> <p>Solenoid may be mechanically actuated by inserting a piece of 3/16" rod against armature pin and pushing spool to opposite end. If valve works, the problem is electrical.</p>
SLIDE STOP WILL NOT FUNCTION IN EITHER DIRECTION	<p>Solenoid coil burned out. Replace coils.</p> <p>Solenoid valve sticking. Replace valve.</p>
SLIDE VALVE and/or SLIDE STOP WILL NOT MOVE	<p>Slipper seals worn out or damaged.</p> <p>Unloader spindle or slide valve jammed.</p> <p>Slide stop indicator rod jammed.</p>

COMPRESSOR PORT LOCATIONS - RXF 12 - 19

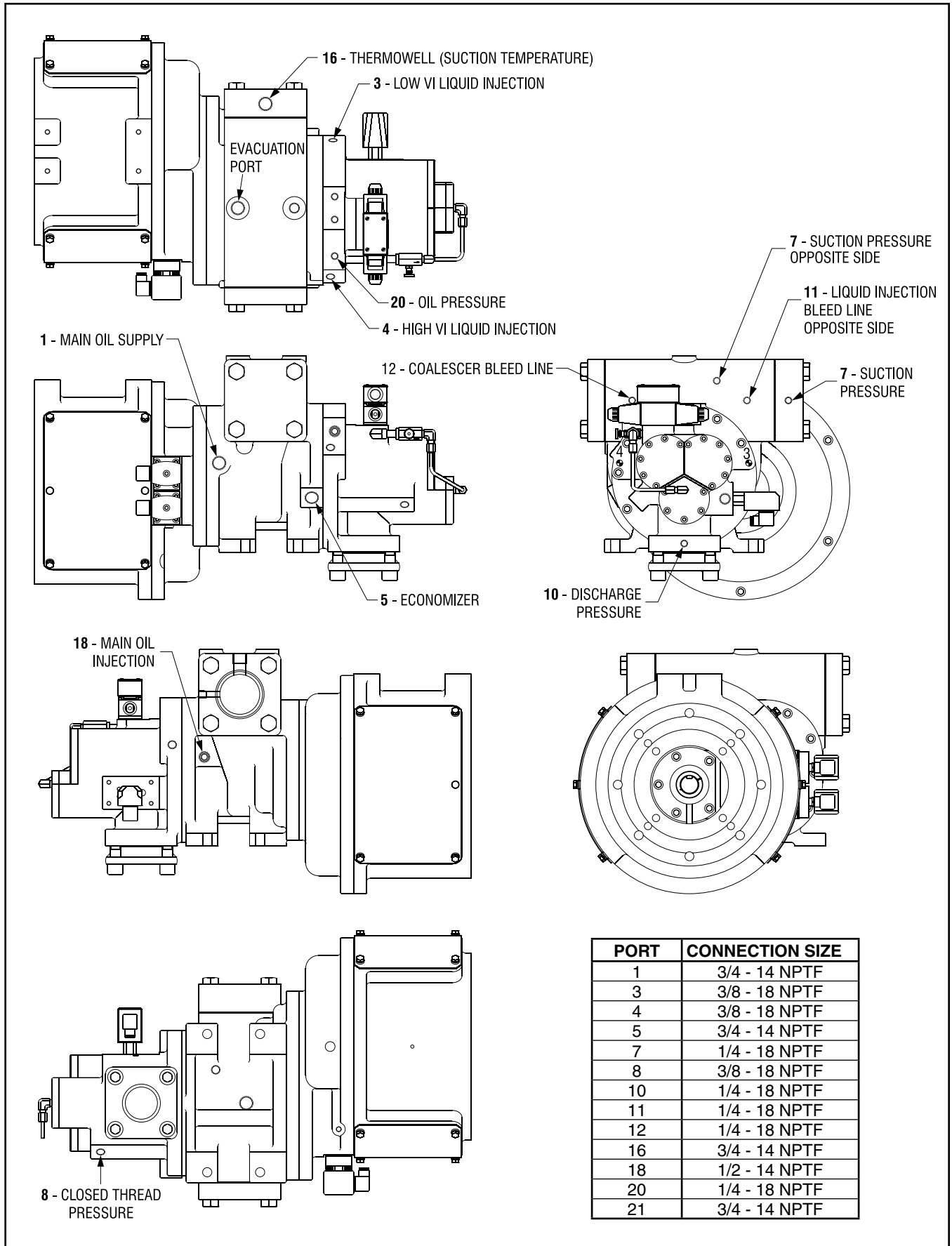

PORT	CONNECTION SIZE
1	3/4 - 14 NPTF
3	3/8 - 18 NPTF
4	3/8 - 18 NPTF
5	3/4 - 14 NPTF
7	1/4 - 18 NPTF
8	3/8 - 18 NPTF
10	1/4 - 18 NPTF
11	1/4 - 18 NPTF
12	1/4 - 18 NPTF
16	3/4 - 14 NPTF
18	1/2 - 14 NPTF
20	1/4 - 18 NPTF
21	3/4 - 14 NPTF

COMPRESSOR PORT LOCATIONS - RXF 24 - 50

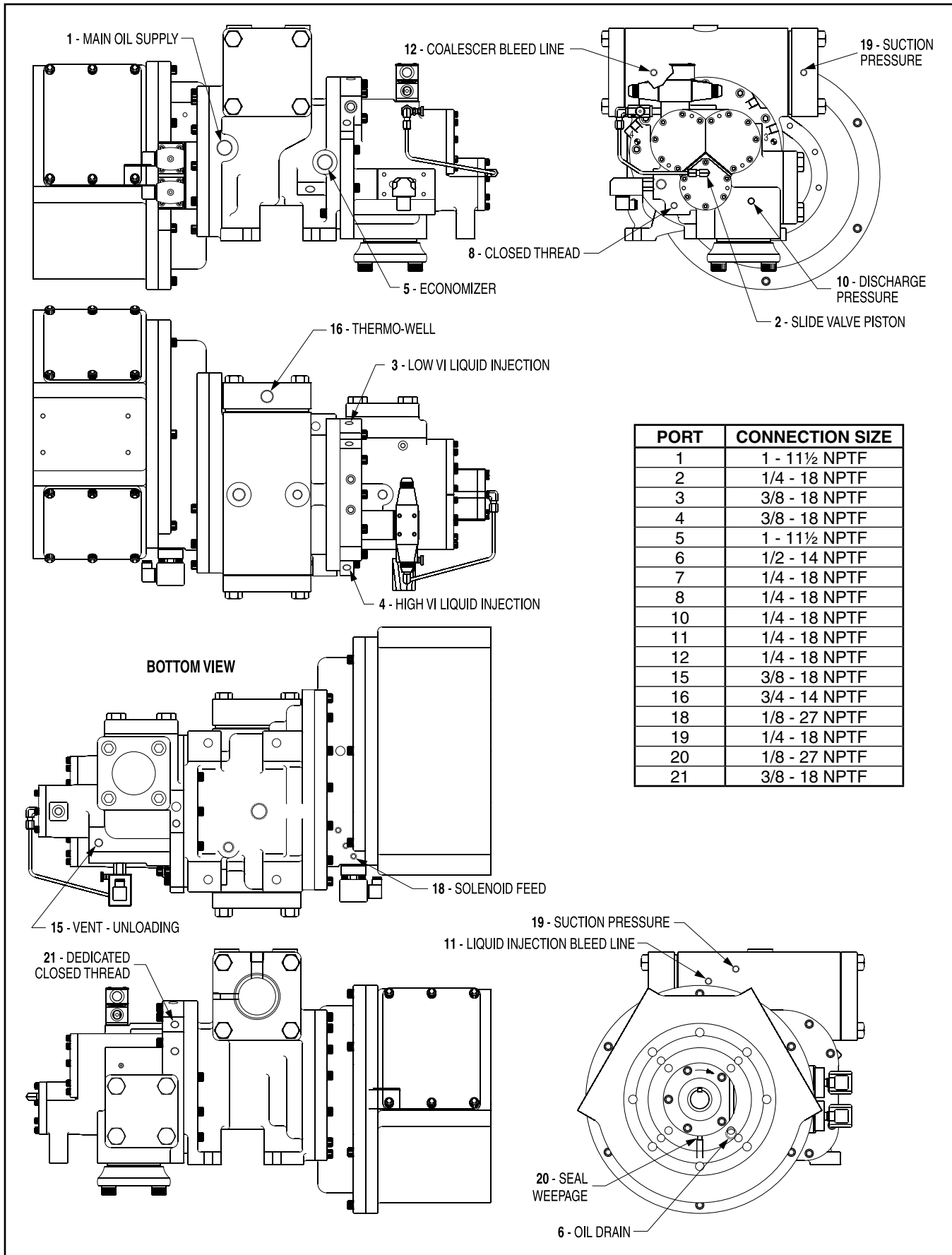

PORT	CONNECTION SIZE
1	1 - 11½ NPTF
2	1/4 - 18 NPTF
3	3/8 - 18 NPTF
4	3/8 - 18 NPTF
5	1 - 11½ NPTF
6	1/2 - 14 NPTF
7	1/4 - 18 NPTF
8	1/4 - 18 NPTF
10	1/4 - 18 NPTF
11	1/4 - 18 NPTF
12	1/4 - 18 NPTF
15	3/8 - 18 NPTF
16	3/4 - 14 NPTF
18	1/8 - 27 NPTF
19	1/4 - 18 NPTF
20	1/8 - 27 NPTF
21	3/8 - 18 NPTF

COMPRESSOR PORT LOCATIONS - RXF 58 - 101

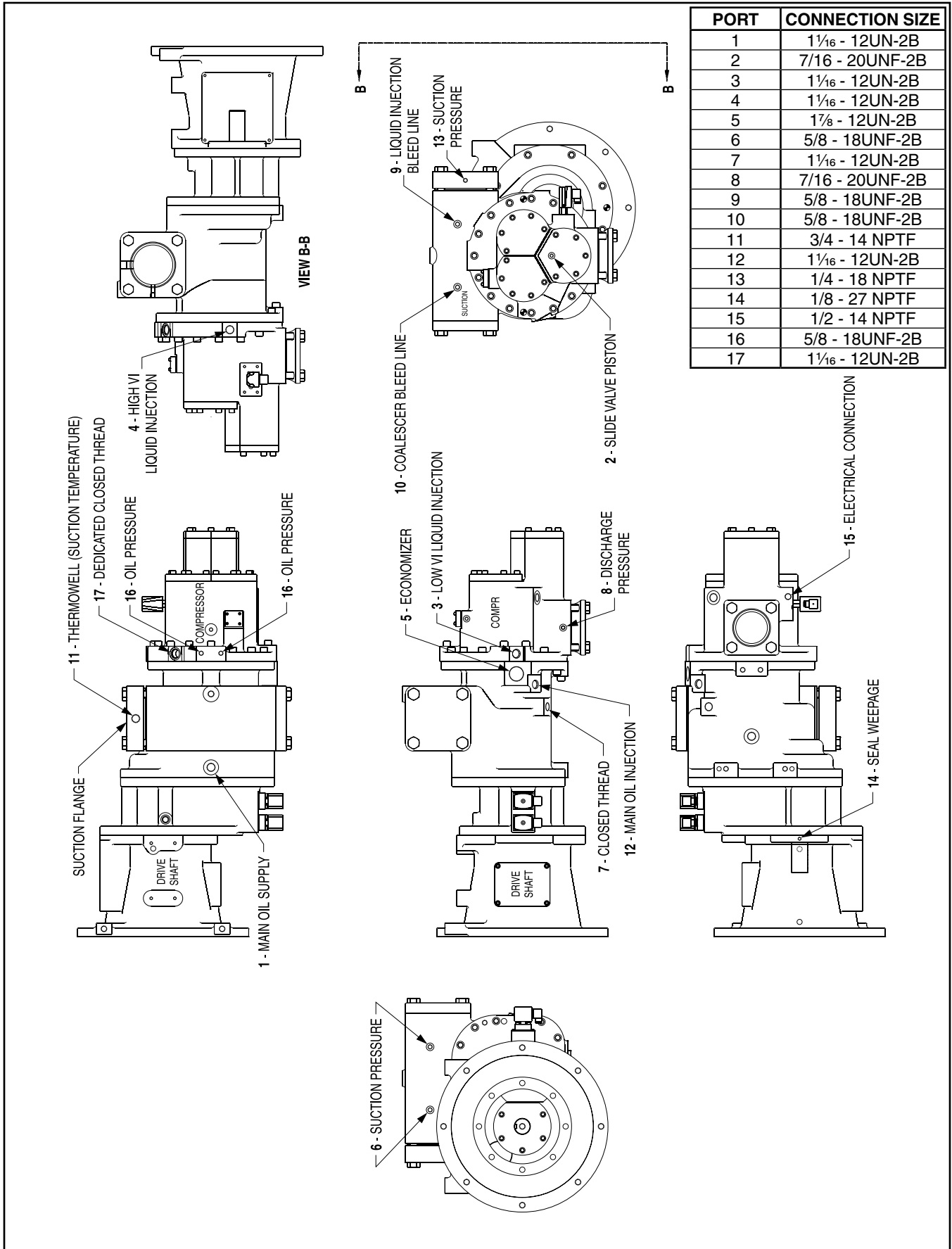

PORT	CONNECTION SIZE
1	1 1/16 - 12UN-2B
2	7/16 - 20UNF-2B
3	1 1/16 - 12UN-2B
4	1 1/16 - 12UN-2B
5	1 7/8 - 12UN-2B
6	5/8 - 18UNF-2B
7	1 1/16 - 12UN-2B
8	7/16 - 20UNF-2B
9	5/8 - 18UNF-2B
10	5/8 - 18UNF-2B
11	3/4 - 14 NPTF
12	1 1/16 - 12UN-2B
13	1/4 - 18 NPTF
14	1/8 - 27 NPTF
15	1/2 - 14 NPTF
16	5/8 - 18UNF-2B
17	1 1/16 - 12UN-2B

P & I DIAGRAM, LIQUID INJECTION – SINGLE PORT

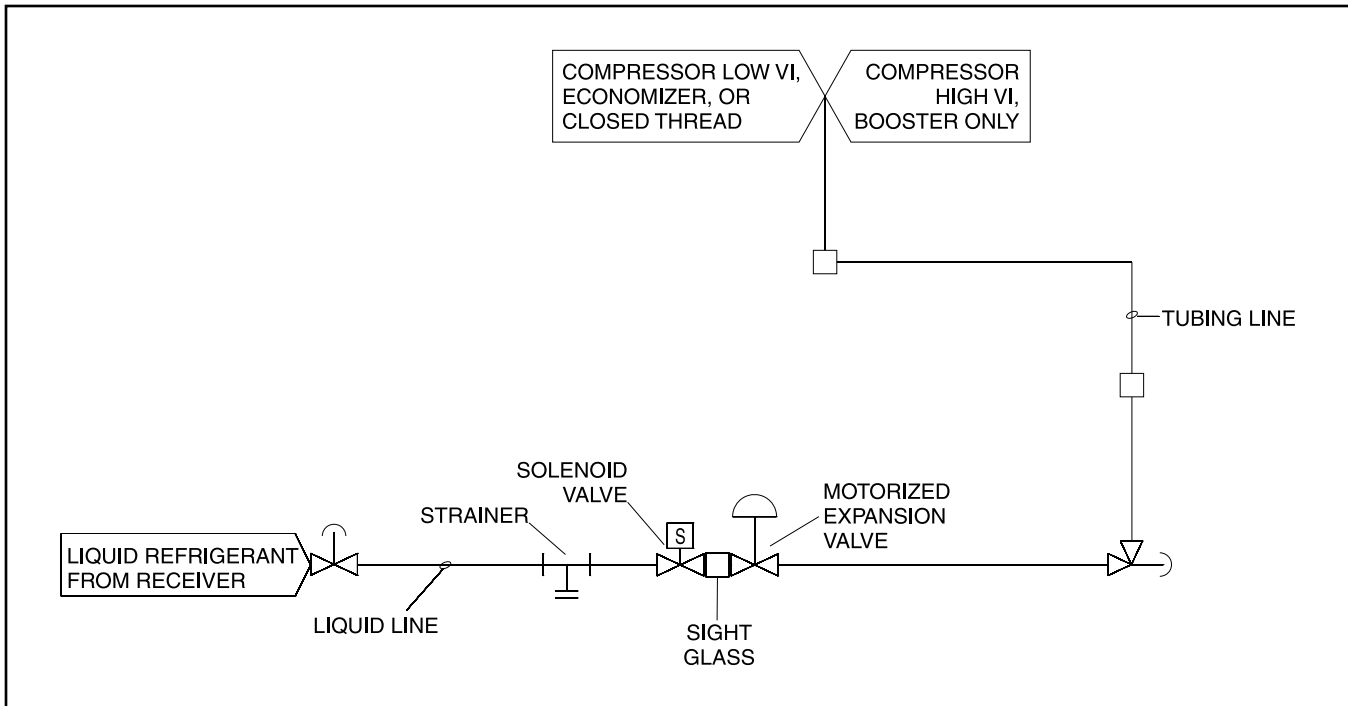

P & I DIAGRAM, LIQUID INJECTION – DUAL PORT

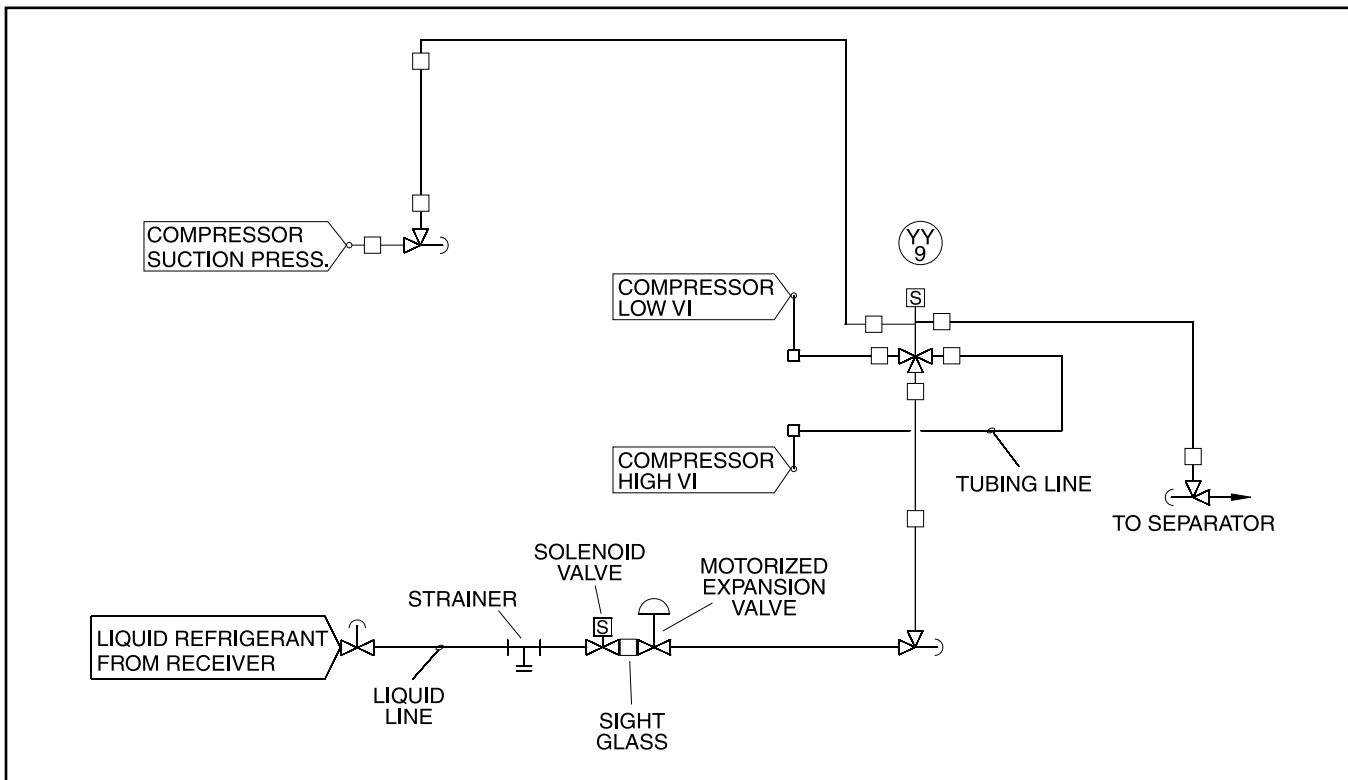

RXF COOLING OPTIONS (See P & I Diagrams)

PLATE OIL COOLER

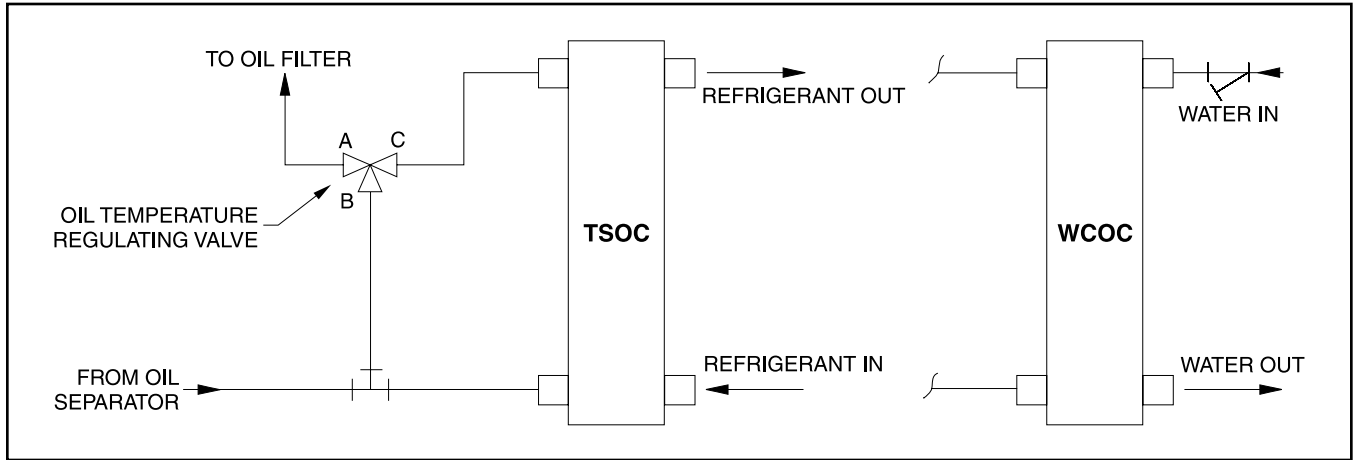

RXF MODELS 12 through 50 without OIL PUMP (See OIL COOLING ADDITIONS)

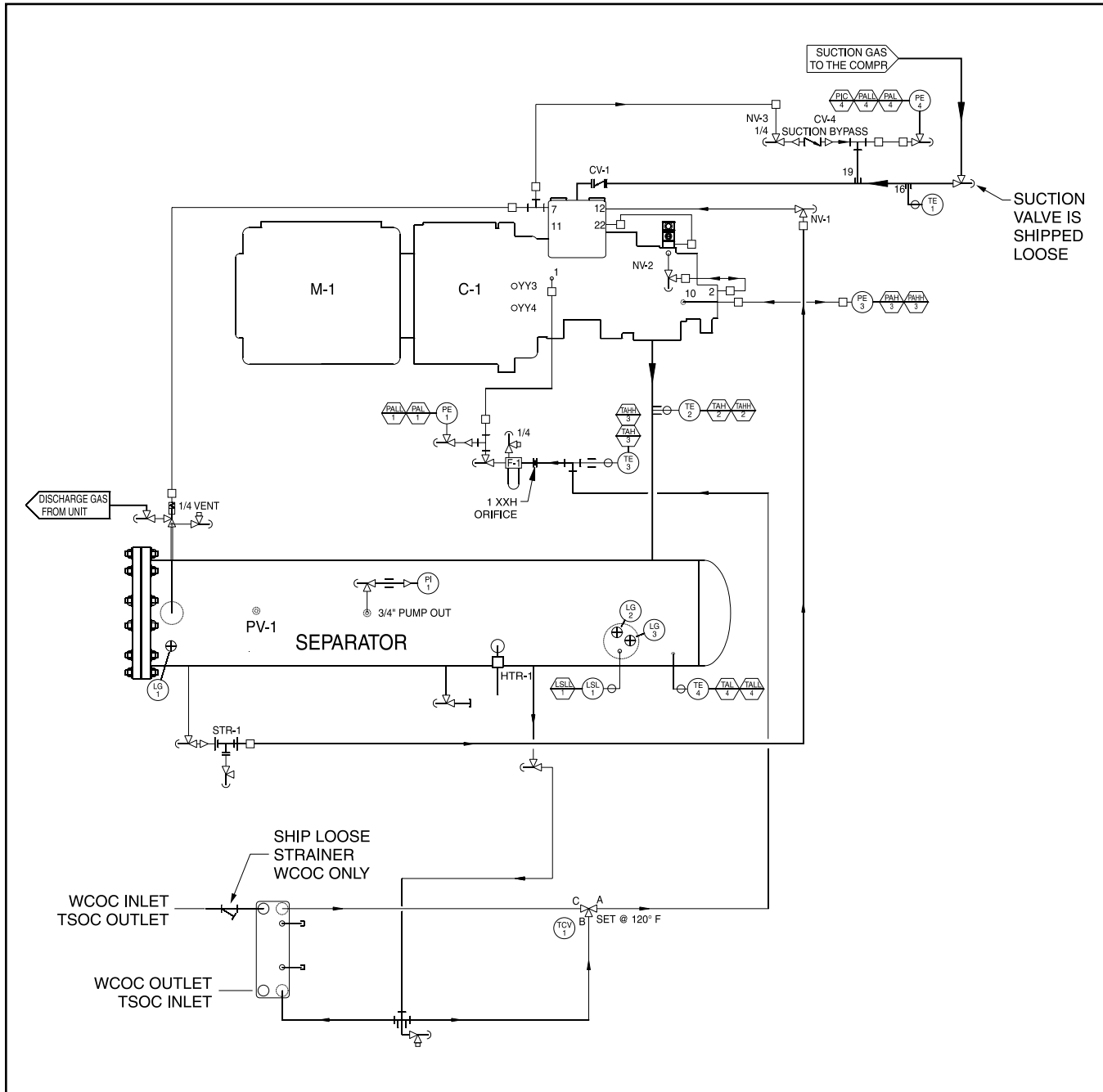

LEGEND*					
AS	AIR SUPPLY	P	PUMP	TAH	HIGH TEMPERATURE ALARM
C	COMPRESSOR	PAH	HIGH PRESSURE ALARM	TAHH	HIGH TEMP. SHUTDOWN
CV	CHECK VALVE	PAHH	HIGH PRESSURE SHUTDOWN	TAL	LOW TEMPERATURE ALARM
DP	DISCHARGE PRESSURE	PAL	LOW PRESSURE ALARM	TALL	LOW TEMPERATURE SHUTDOWN
F	FILTER OR FILTER DRIER	PALL	LOW PRESSURE SHUTDOWN	TCV	TEMPERATURE CONTROL VALVE
FG	FLOW GLASS	PCV	PRESSURE CONTROL VALVE	TE	TEMPERATURE ELEMENT
HTR	HEATER	PDSLL	LOW DIFFERENTIAL PRESS. SHUTDOWN	TI	TEMPERATURE INDICATOR
HV	HAND ACTUATED VALVE	PE	PRESSURE ELEMENT	TS	TEMPERATURE SWITCH
LG	SIGHT OR LEVEL GLASS	PI	PRESSURE INDICATOR	TSH	TEMP. SWITCH HIGH ALARM
LSL	OIL LEVEL SWITCH LOW	PIC/TIC	PRESS./TEMP. INDICATING CONTROLLER	TSLI	LIQUID INJECTION SHUTOFF
LSLL	LOW OIL LEVEL SHUTDOWN	PM	PUMP MOTOR	TW	THERMOWELL
M	MOTOR	PS	AUTO CYCLE/PRESSURE SWITCH	VI	VI CONTROL
1MC	MOTOR CONTROL CENTER	PSV	PRESSURE SAFETY VALVE	WS	WATER SUPPLY
2MC	MOTOR CONTROL CENTER	SP	SUCTION PRESSURE	YY	SOLENOID VALVE/EVENT VALVE
OP	OIL PRESSURE	STR	STRAINER		

* See additional Legend items on opposite page.

RXF MODELS 12 through 50 with OIL PUMP (See OIL COOLING ADDITIONS)

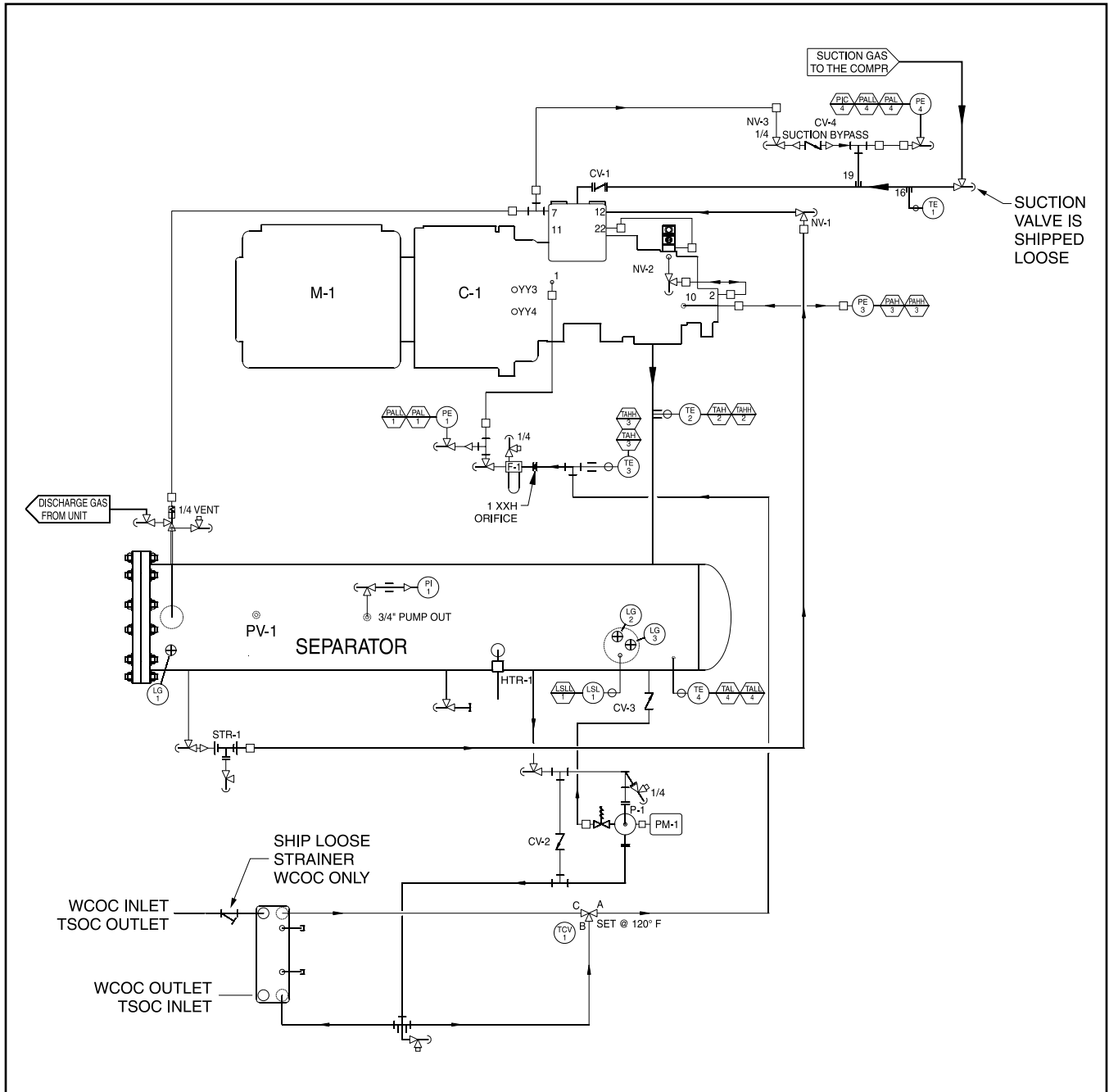

LEGEND (Cont.)

CONNECTIONS		NOTES:
1	MAIN OIL SUPPLY	1. PRESSURE TRANSDUCERS INDICATE: PE-1 OIL PRESSURE PE-3 DISCHARGE PRESSURE PE-4 SUCTION PRESSURE
2	SLIDE VALVE PISTON	
3	LOW VI LIQUID INJECTION	
4	HIGH VI LIQUID INJECTION	2. TEMPERATURE PROBES INDICATE: TE-1 SUCTION GAS TEMPERATURE TE-2 DISCHARGE GAS TEMPERATURE TE-3 LUBE OIL TEMPERATURE TE-4 SEPARATOR OIL TEMPERATURE
5	ECONOMIZER	
6	OIL DRAIN	
7	SUCTION PRESSURE	3. TERMINATIONS "A" THROUGH "C" REFER TO CONNECTION POINTS FOR VARIOUS OPTIONS.
8	CLOSED THREAD	
10	DISCHARGE PRESSURE	
11	LIQ. INJ. BLEED LINE	
12	COALESCER BLEED LINE	
15	VENT - UNLOADING	
16	THERMOWELL	
19	SUCTION PRESSURE	

RXF MODELS 58, 68, 85, & 101 without OIL PUMP (See OIL COOLING ADDITIONS)

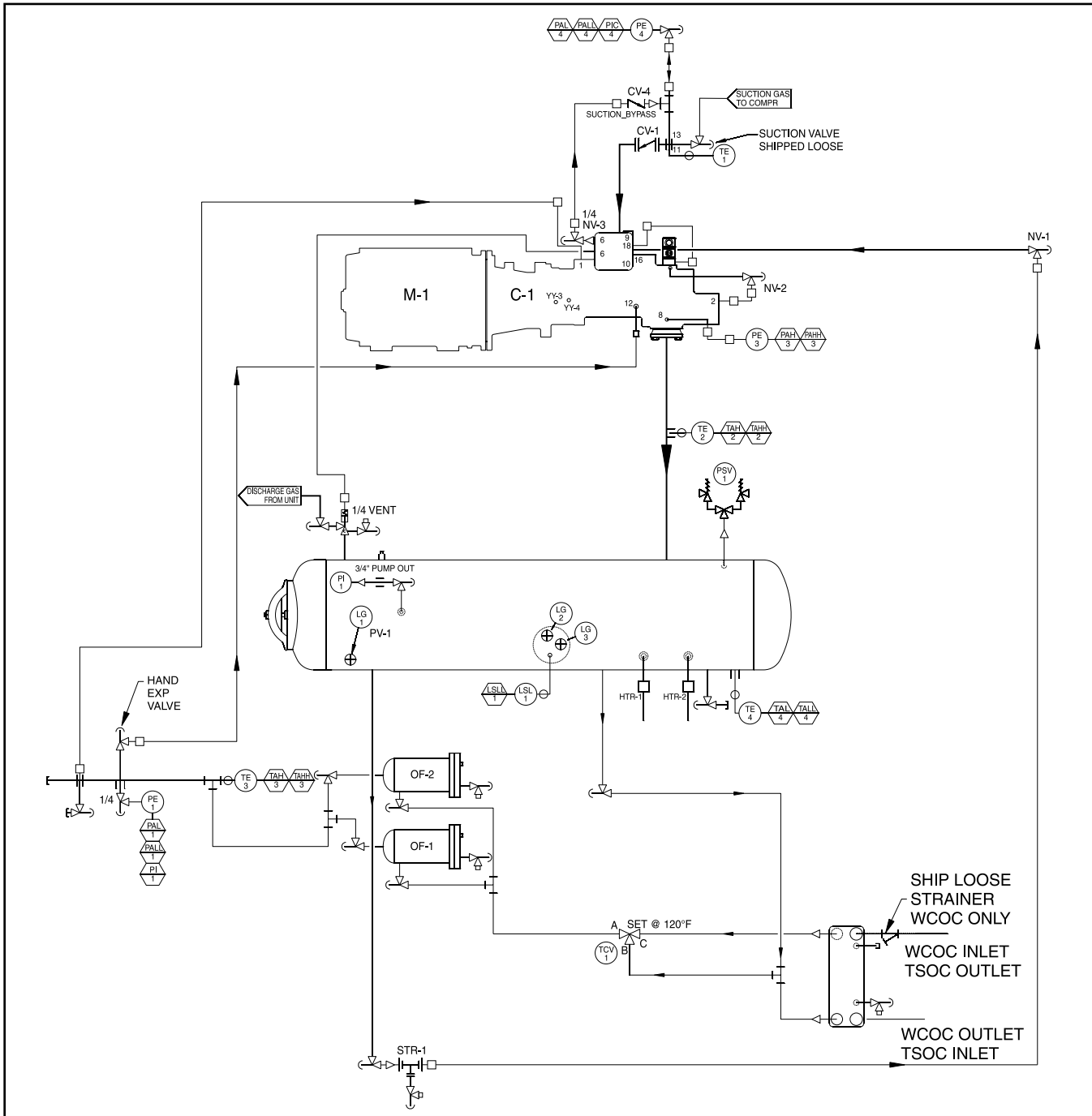

LEGEND*

AS	AIR SUPPLY	P	PUMP	TAH	HIGH TEMPERATURE ALARM
C	COMPRESSOR	PAH	HIGH PRESSURE ALARM	TAHH	HIGH TEMP. SHUTDOWN
CV	CHECK VALVE	PAHH	HIGH PRESSURE SHUTDOWN	TAL	LOW TEMPERATURE ALARM
DP	DISCHARGE PRESSURE	PAL	LOW PRESSURE ALARM	TALL	LOW TEMPERATURE SHUTDOWN
F	FILTER OR FILTER DRIER	PALL	LOW PRESSURE SHUTDOWN	TCV	TEMPERATURE CONTROL VALVE
FG	FLOW GLASS	PCV	PRESSURE CONTROL VALVE	TE	TEMPERATURE ELEMENT
HTR	HEATER	PDSLL	LOW DIFFERENTIAL PRESS. SHUTDOWN	TI	TEMPERATURE INDICATOR
HV	HAND ACTUATED VALVE	PE	PRESSURE ELEMENT	TS	TEMPERATURE SWITCH
LG	SIGHT OR LEVEL GLASS	PI	PRESSURE INDICATOR	TSH	TEMP. SWITCH HIGH ALARM
LSL	OIL LEVEL SWITCH LOW	PIC/TIC	PRESS./TEMP. INDICATING CONTROLLER	TSL	LIQUID INJECTION SHUTOFF
LSLL	LOW OIL LEVEL SHUTDOWN	PM	PUMP MOTOR	TW	THERMOWELL
M	MOTOR	PS	AUTO CYCLE/PRESSURE SWITCH	VI	VI CONTROL
1MC	MOTOR CONTROL CENTER	PSV	PRESSURE SAFETY VALVE	WS	WATER SUPPLY
2MC	MOTOR CONTROL CENTER	SP	SUCTION PRESSURE	YY	SOLENOID VALVE/EVENT VALVE
OP	OIL PRESSURE	STR	STRAINER		

* See additional Legend items on opposite page.

RXF Models 58, 68, 85, & 101 with OIL PUMP and DUAL OIL FILTERS (See OIL COOLING ADDITIONS)

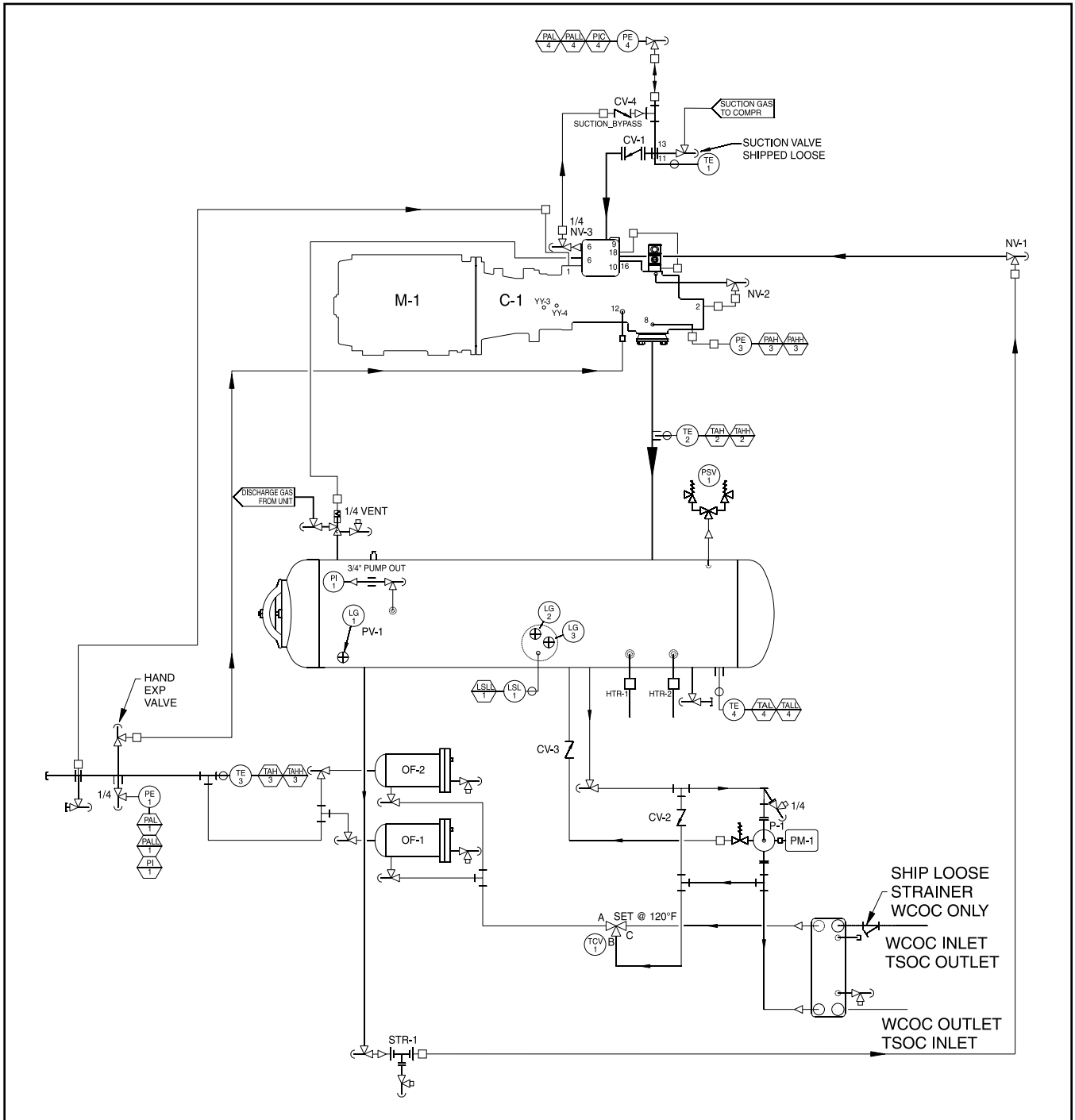

LEGEND (Cont.)

CONNECTIONS		LEGEND (Cont.)		NOTES:
1	MAIN OIL SUPPLY	12	MAIN OIL INJECTION	1. PRESSURE TRANSDUCERS INDICATE: PE-1 OIL PRESSURE PE-3 DISCHARGE PRESSURE PE-4 SUCTION PRESSURE
2	SLIDE VALVE PISTON	13	SUCTION PRESSURE	
3	LOW VI LIQUID INJECTION	14	SEAL WEEPAGE	
4	HIGH VI LIQUID INJECTION	15	ELECTRICAL CONNECTION	2. TEMPERATURE PROBES INDICATE: TE-1 SUCTION GAS TEMPERATURE TE-2 DISCHARGE GAS TEMPERATURE TE-3 LUBE OIL TEMPERATURE TE-4 SEPARATOR OIL TEMPERATURE
5	ECONOMIZER	16	OIL PRESSURE	
6	SUCTION PRESSURE			
7	CLOSED THREAD			3. TERMINATIONS "A" THROUGH "C" REFER TO CONNECTION POINTS FOR VARIOUS OPTIONS.
8	DISCHARGE PRESSURE			
9	LIQ. INJ. BLEED LINE			
10	COALESCER BLEED LINE			
11	THERMOWELL (SUCT. TEMP.)			

WIRING HARNESS - External for Analog Devices

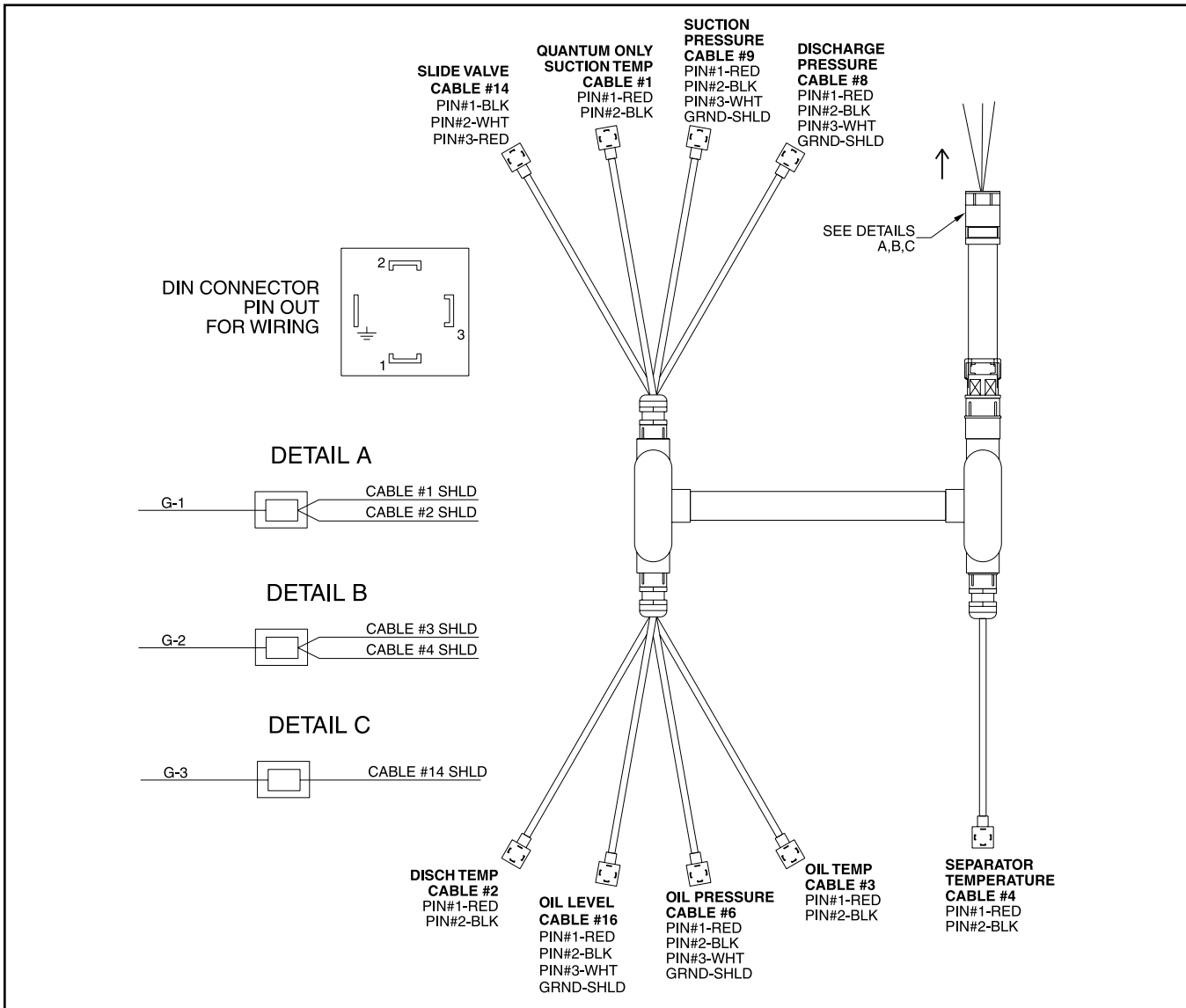

WIRING HARNESS - AC to Heaters and Valves (External)

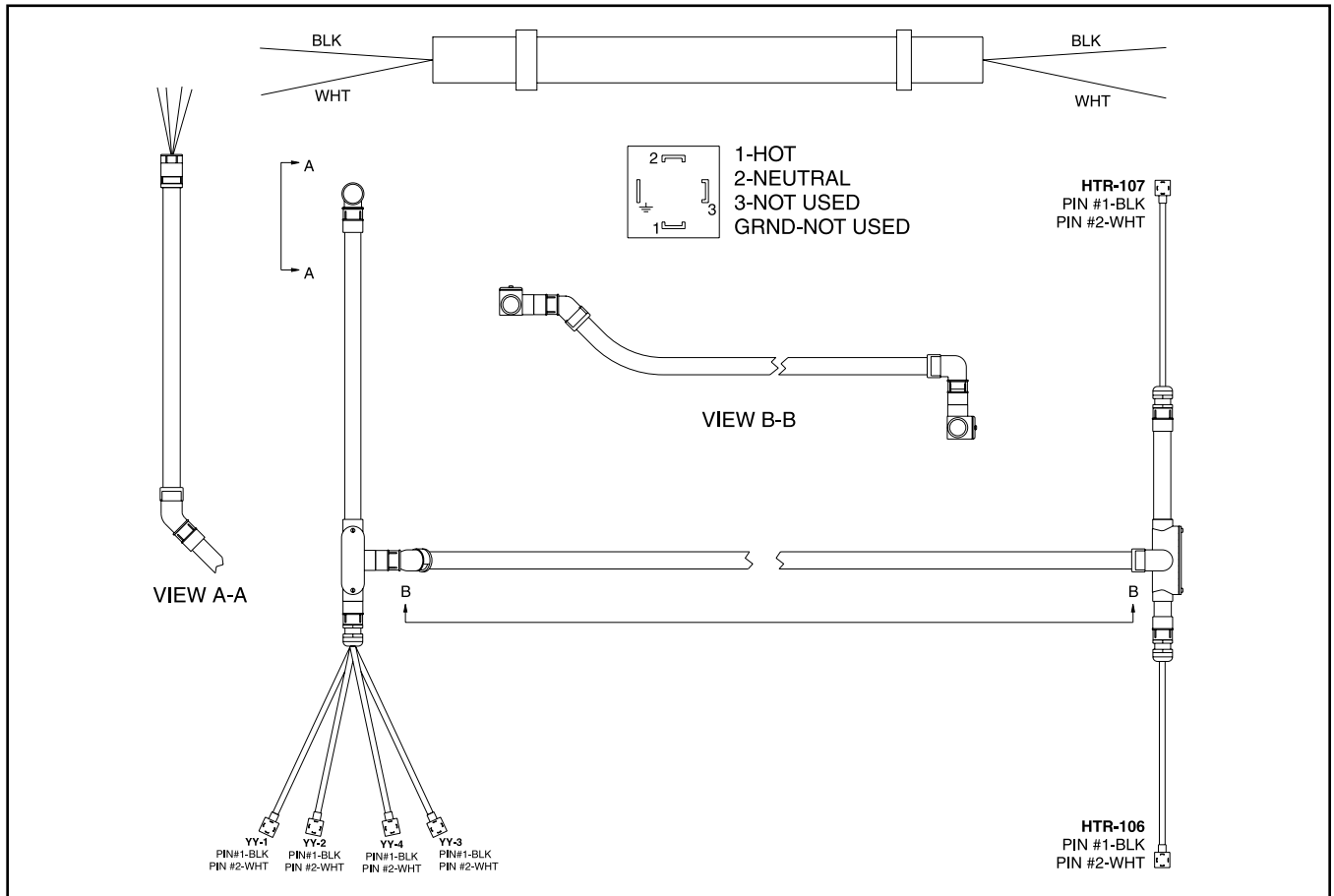

WIRING HARNESS - AC Conduit - Quantum to DBS Panel

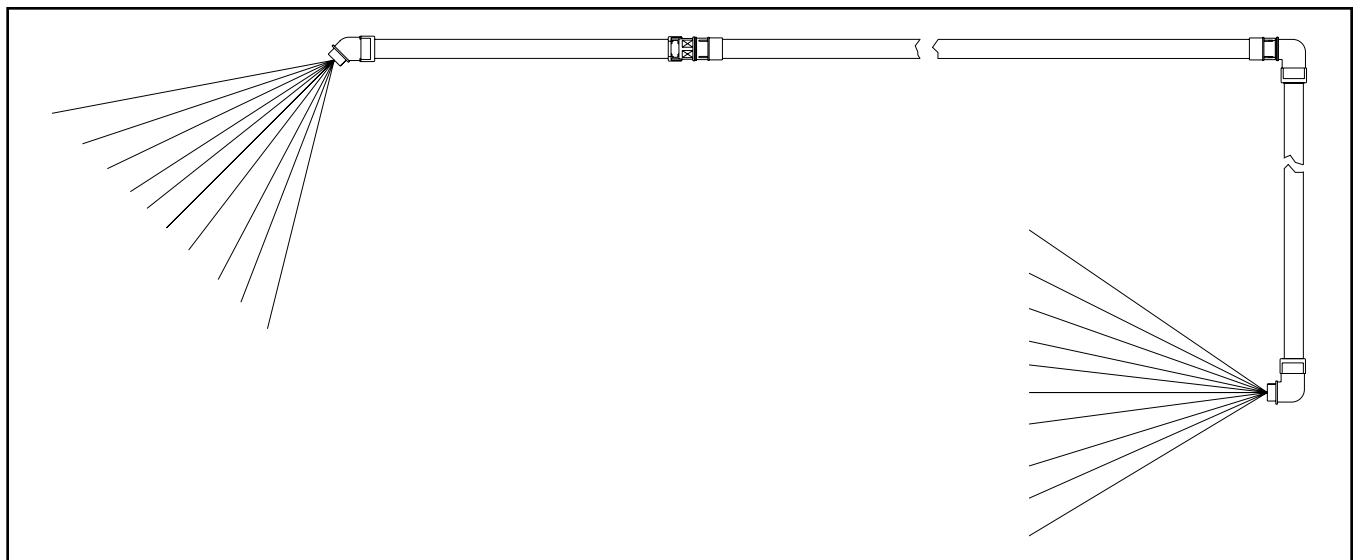

PROPER INSTALLATION OF ELECTRONIC EQUIPMENT IN AN INDUSTRIAL ENVIRONMENT

In today's refrigeration plants, electronic controls have found their way into almost every aspect of refrigeration control. Electronic controls have brought to the industry more precise control, improved energy savings, and operator conveniences. Electronic control devices have revolutionized the way refrigeration plants operate today.

The earlier relay systems were virtually immune to radio frequency interference (RFI), electromagnetic interference (EMI), and ground loop currents. Therefore installation and wiring were of little consequence and the wiring job consisted of hooking up the point-to-point wiring and sizing the wire properly. In an electronic system, improper installation will cause problems that may outweigh the benefits of electronic control. Electronic equipment is susceptible to RFI, EMI, and ground loop currents which can cause equipment shutdowns, processor memory and program loss, as well as erratic behavior and false readings. Manufacturers of industrial electronic equipment take into consideration the effects of RFI, EMI, and ground loop currents and incorporate protection of the electronics in their designs. However, these design considerations do not make the equipment immune, so manufacturers require that certain installation precautions be taken to protect the electronics from these effects. All electronic equipment must be viewed as sensitive instrumentation and therefore requires careful attention to installation procedures. These procedures are well known to instrumentation, networking, and other professions but may not be followed by general electricians.

There are a few basic practices that if followed, will minimize the potential for problems resulting from RFI, EMI and/or ground loop currents. The National Electric Code (NEC) is a guideline for safe wiring practices, but it does not necessarily deal with procedures used for electronic control installation. Use the following procedures for electronic equipment installation. These procedures do not override any rules by the NEC, but are to be used in conjunction with the NEC code and any other applicable codes.

With exclusion of the three phase wire sizing, Frick drawing 649D4743 should be used as a reference for properly sizing control wires and other wiring specifications.

Throughout this document the term Electronic Control Panel is used to refer to the microprocessor mounted on the compressor package or a Central Control System panel.

NOTE: It is very important to read the installation instructions thoroughly before beginning the project. Make sure you have drawings and instructions with your equipment. If not, call the manufacturer and request the proper instructions and drawings. Every manufacturer of electronic equipment should have a knowledgeable staff, willing to answer your questions or provide additional information. Following correct wiring procedures will ensure proper installation and consequently, proper operation of your electronic equipment.

WIRE SIZING

Control power supply wires should be sized one size larger than required for amperage draw to reduce instantaneous voltage dips caused by large loads such as heaters, contactors, and solenoids. These sudden dips in voltage can cause the electronic control panel, whether it is a microprocessor, a computer, or a PLC, to malfunction momentarily or cause a complete reset of the control system. If the wire is

loaded to its maximum capacity, the voltage dips are much larger, and the potential of a malfunction is very high. If the wire is sized one size larger than required, the voltage dips are smaller than in a fully loaded supply wire and the potential for malfunction is much lower. The NEC code book calls for specific wire sizes to be used based on current draw. An example of this would be to use #14 gauge wire for circuits up to 15 amps or #12 gauge wire for circuits of up to 20 amps. Therefore, when connecting the power feed circuit to an electronic control panel, use #12 gauge wire for a maximum current draw of 15 amp and #10 wire for a maximum current draw of 20 amp. Use this rule of thumb to minimize voltage dips at the electronic control panel.

VOLTAGE SOURCE

Selecting the voltage source is extremely important for proper operation of electronic equipment in an industrial environment. Standard procedure for electronic instrumentation is to provide a clean, isolated, separate-source voltage in order to prevent EMI (from other equipment in the plant) from interfering with the operation of the electronic equipment. Connecting electronic equipment to a breaker panel (also known as lighting panels or utility panels) subjects the electronic equipment to noise generated by other devices connected to the breaker panel. This noise is known as electromagnetic interference (EMI). EMI flows on the wires that are common to a circuit. EMI cannot travel easily through transformers and therefore can be isolated from selected circuits. Use a control power transformer of the proper VA rating, usually provided in the compressor drive motor starter, to isolate the electronic control panel from other equipment in the plant that generate EMI. See Figure 35.

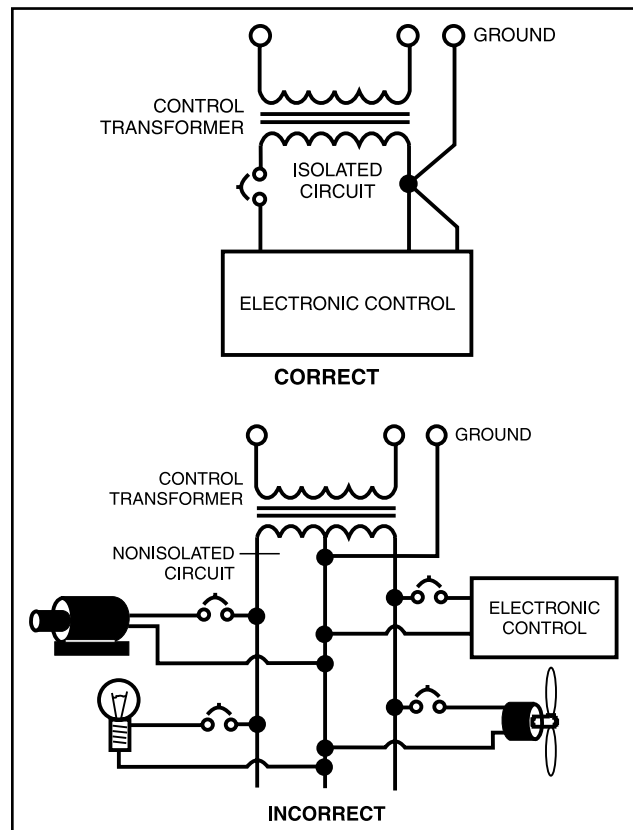

Figure 35

GROUNDING

Grounding is the most important factor for successful operation and is typically the most overlooked. The NEC states that control equipment may be grounded by using the rigid conduit as a conductor. This worked for the earlier relay systems, but it is in no way acceptable for electronic control equipment. Conduit is made of steel and is a poor conductor relative to an insulated stranded copper wire. Electronic equipment reacts to very small currents and must have a proper ground in order to operate properly; therefore, stranded copper grounds are required for proper operation.

For proper operation, the control power ground circuit must be a single continuous circuit of the proper sized insulated stranded conductor, from the electronic control panel to the plant supply transformer (Figure 36). Driving a ground stake at the electronic control may also cause additional problems since other equipment in the plant on the same circuits may ground themselves to the ground stake causing large ground flow at the electronic control panel. Also, running multiple ground conductors into the electronic control panel from various locations can create multiple potentials resulting in ground loop currents. A single ground wire (10 AWG or 8 AWG) from the electronic control panel, that is bonded to the control power neutral at the secondary side of the control power transformer in the starter and then to the 3-phase ground point, will yield the best results.

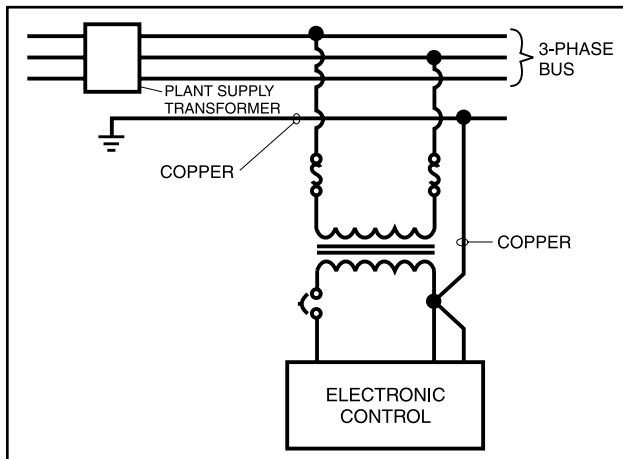

Figure 36

NOTE: Structural grounding can also result in multiple ground potentials and is also a relatively poor conductor. Therefore, this is not an acceptable method for proper operation of electronic equipment.

There must be a ground for the three-phase power wiring. This must be sized in accordance to the NEC and any local codes relative to the highest rated circuit overload protection provided in the circuit. The manufacturer may require a larger ground conductor than what is required by the NEC for proper steering of EMI from sensitive circuits. This conductor must also be insulated to avoid inadvertent contact at multiple points to ground, which could create Ground Loops. In many installations that are having electronic control problems, this essential wire is usually missing, is not insulated, or improperly sized.

NEC size ratings are for safety purposes and not necessarily for adequate relaying of noise (EMI) to earth ground to avoid possible interference with sensitive equipment. Therefore sizing this conductor 1 – 2 sizes larger than required by code will provide better transfer of this noise.

Frick requires that the ground conductor meet the following requirements be:

- Stranded Copper
- Insulated
- One size larger than NEC requirements for conventional starters
- Two sizes larger than NEC requirements for VFD starters
- Conduit must be grounded at each end
- This circuit must be complete from the motor to the starter continuing in a seamless manner back to the plant supply transformer (power source).

For Direct Coupled, Package Mounted Starters, the ground between the motor and the starter may need to be made externally (Figure 37). The connection on the starter end must be on the starter side of the vibration isolators. Be certain the connection is metal to metal. Paint may need to be removed to ensure a proper conductive circuit. The use of counter-sunk star washers at the point of connection at each end will maximize metal to metal contact.

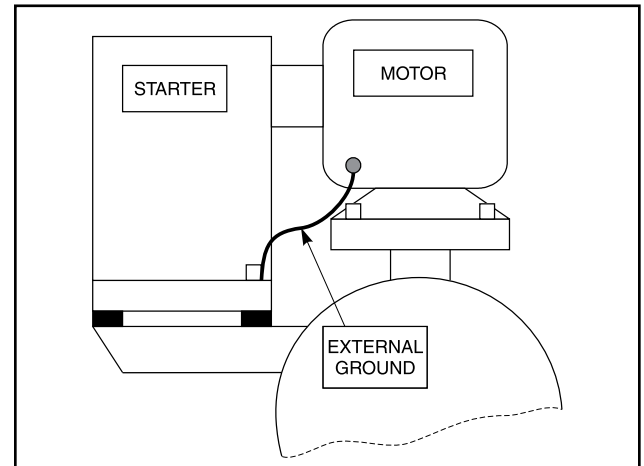

Figure 37

VFD APPLICATIONS

The primary ground conductor that accompanies the three-phase supply must be stranded copper, insulated and two sizes larger than the minimum required by the NEC or any other applicable codes. This is necessary due to the increased generation of EMI which is a characteristic of a VFD output to the motor when compared to a conventional starter.

For VFD applications, isolation of the control power, analog devices, and communications ground from the 3-phase ground within the starter and the electronic control panel may be necessary. This is due to the higher noise (RFI/EMI) levels generated between the VFD output and the motor, relative to a conventional starter. If these grounds are left coupled

by a common back-plate in the starter/drive, this noise can be direct coupled to the control power, analog device, and communications grounding and may cause unexplained behavior and possible damage to components.

To install correctly, run a separate, properly sized (10 or 8 AWG typically) insulated ground along with and taken to ground with, the 3-phase ground at the 3-phase supply transformer (plant). This will require that the 3-phase ground and the control power ground be electrically isolated except for the connection at the plant supply transformer.

This style of grounding should steer the noise (EMI/RFI) to earth ground, reducing the potential for it to affect the sensitive equipment, which could occur if the grounds were left coupled. **NOTE: If all other recommendations for grounding are followed, this process should not be necessary.**

CONDUIT

All national and local codes must be followed for conduit with regard to materials, spacing and grounding. In addition, **Johnson Controls-Frick requirements must be followed where they exceed or match national or local codes. Conversely, there is no allowance for any practices that are substandard to what is required by national or local codes.**

Johnson Controls-Frick conduit requirements:

- For *variable frequency drives* (VFDs) of any type, threaded metallic or threaded PVC-coated metallic is required for both the power feed (line side) from the source and between the VFD output and the motor (load side).
- PVC conduit is acceptable **only** when *VFD rated cable* of the proper conductor size and ground is used. This applies to both the line side and load side of the drive. When VFD rated cable is not used, threaded metallic or threaded PVC-coated metallic must be used.
- When threaded metallic or threaded PVC-coated metallic is used, it must be grounded at both ends.
- When not required to be in metal or other material by national or local codes, conduits for the power feed (3-phase) of constant speed starters may be PVC.
- When not required to be in metal or other material by national or local codes, conduits between a constant speed starter and the motor (3-phase) may be PVC.
- Any unshielded control voltage, signal, analog, or communication wiring that does not maintain 12 inches of separation from any 3-phase conductors for every 33 feet (10 meters) of parallel run must be in metal conduit which will be grounded.

Separation: (0-33 feet, 0-10 meters – 12 inches, .3 meters), (33-66 feet, 10-20 meters – 24 inches, .6 meters)

- Since PVC conduit does absolutely nothing to protect lower voltage lines from the magnetic field effects of higher voltage conductors, running either the lower or the higher voltage lines in PVC, does not reduce these requirements on separation. Only running in metal conduit can relieve these requirements.
- Due to the level of EMI that can be induced onto lower voltage lines when running multiple feeders in a trench, control power, communications, analog, or signal wiring

cannot be run in trenches that house multiple conduits/ electrical ducts carrying 3-phase power to starters/vfd or motors.

- Control power, communications, analog, or signal wiring should be run overhead (preferred) or in a separate trench. If these lines are not in threaded metallic or threaded PVC-coated metallic, abiding by the separation requirements noted above is necessary.
- Though not recommended, if cable trays are used, *metallic* dividers must be used for separation of conductors of unlike voltages and types (AC or DC).

NOTE: When in doubt contact the factory or use threaded metallic or threaded PVC coated metallic conduit.

WIRING PRACTICES

Do not mix wires of different voltages in the same conduit. An example of this would be the installation of a screw compressor package where the motor voltage is 480 volts and the electronic control panel power is 120 volts. The 480 volt circuit must be run from the motor starter to the motor in its own conduit. The 120 volt circuit must be run from the motor starter control transformer to the electronic control panel in its own separate conduit. If the two circuits are run in the same conduit, transients on the 480 volt circuit will be induced onto the 120 volt circuit causing functional problems with the electronic control panel. Metallic dividers must be used in wire way systems (conduit trays) to separate unlike voltages. The same rule applies for 120 volt wires and 220 volt wires. Also, never run low voltage wires for DC analog devices or serial communications in the same conduit with any AC wiring including 120 volt wires. See Figure 38.

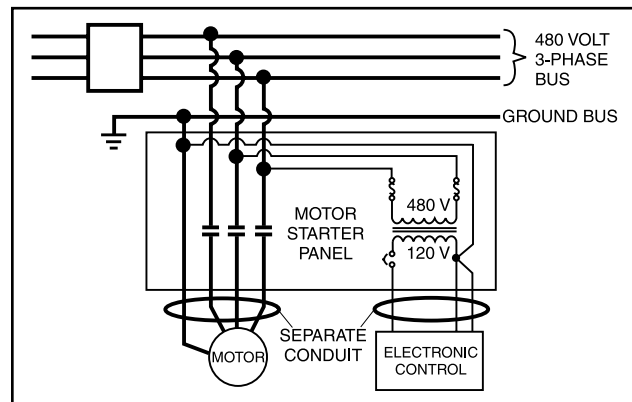

Figure 38

Never run any wires through an electronic control panel that do not relate to the function of the panel. Electronic control panels should never be used as a junction box. These wires may be carrying large transients that will interfere with the operation of the control panel. **An extreme example of this would be to run 480 volts from the starter through the electronic control panel to an oil pump motor.**

When running conduit to the electronic control panel, use the access holes (knockouts) provided by the manufacturer. These holes are strategically placed so that the field wiring does not interfere with the electronics in the panel. Never allow field wiring to come in close proximity with the controller boards since this will almost always cause problems.

Do not drill into an electronic control panel to locate conduit connections. You are probably not entering the panel where the manufacturer would like you to since most manufacturers recommend or provide prepunched conduit connections. You may also be negating the NEMA rating of the enclosure. Drilling can cause metal filings to land on the electronics and create a short circuit when powered is applied. If you must drill the panel, take the following precautions:

- First, call the panel manufacturer before drilling into the panel to be sure you are entering the panel at the right place.
- Take measures to avoid ESD (electrostatic discharge) to the electronics as you prep the inside of the Electronic control panel. This can be done by employing an antistatic wrist band and mat connected to ground.
- Cover the electronics with plastic and secure it with masking or electrical tape.
- Place masking tape or duct tape on the inside of the panel where you are going to drill. The tape will catch most of the filings.
- Clean all of the remaining filings from the panel before removing the protective plastic.

When routing conduit to the top of an electronic control panel, condensation must be taken into consideration. Water can condense in the conduit and run into the panel causing catastrophic failure. Route the conduit to the sides or bottom of the panel and use a conduit drain. If the conduit must be routed to the top of the panel, use a sealable conduit fitting which is poured with a sealer after the wires have been pulled, terminated, and the control functions have been checked. A conduit entering the top of the enclosure must have a NEMA-4 hub type fitting between the conduit and the enclosure so that if water gets on top of the enclosure it cannot run in between the conduit and the enclosure. This is extremely important in outdoor applications.

NOTE: It is simply NEVER a good practice to enter through the top of an electronic control panel or starter panel that does not already have knockouts provided. If knockouts are not provided for this purpose it is obvious this is not recommended and could VOID WARRANTY.

Never add relays, starters, timers, transformers, etc. inside an electronic control panel without first contacting the manufacturer. Contact arcing and EMI emitted from these devices can interfere with the electronics. Relays and timers are routinely added to electronic control panels by the manufacturer, but the manufacturer knows the acceptable device types and proper placement in the panel that will keep interference to a minimum. If you need to add these devices, contact the manufacturer for the proper device types and placement.

Never run refrigerant tubing inside an electronic control panel. If the refrigerant is ammonia, a leak will totally destroy the electronics.

If the electronic control panel has a starter built into the same panel, be sure to run the higher voltage wires where indicated by the manufacturer. EMI from the wires can interfere with the electronics if run too close to the circuitry.

Never daisy-chain or parallel-connect power or ground wires to electronic control panels. Each electronic control panel must have its own control power supply and ground wires back to the power source (Plant Transformer). Multiple electronic control panels on the same power wires create current surges in the supply wires, which may cause controller malfunctions. Daisy-chaining ground wires, taking them to ground at each device, allows ground loop currents to flow between electronic control panels which also causes malfunctions. See Figure 39.

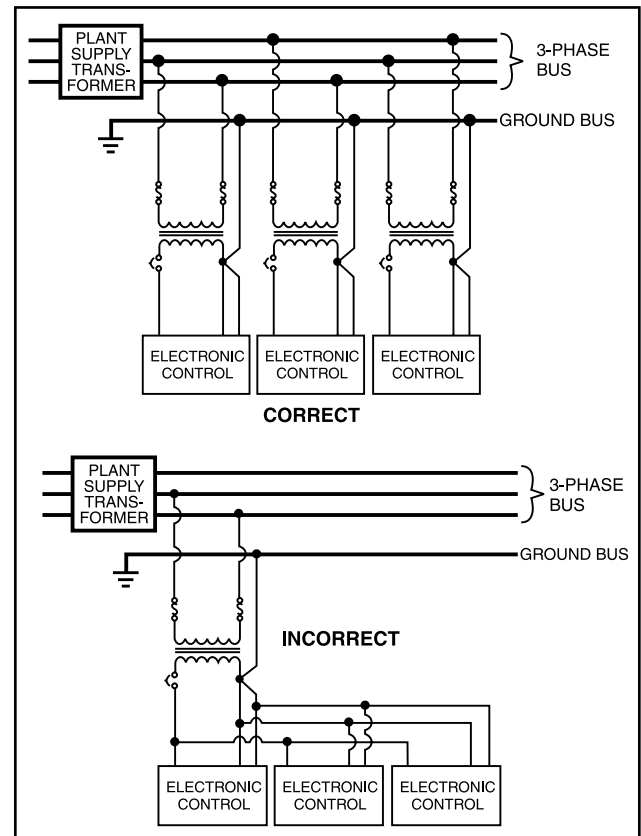

Figure 39

COMMUNICATIONS

The use of communications such as serial and ethernet in industrial environments are commonplace. The proper installation of these networks is as important to the proper operation of the communications as all of the preceding practices are to the equipment.

Serial communications cable needs to be of the proper gauge based on the total cable distance of the run. Daisy-chaining is the only acceptable style of running the communications cable. While Star Networks may use less cable, they more often than not cause problems and interruptions in communications, due to varying impedances over the varying lengths of cable. Ground or drain wires of the communications cable are to be tied together at each daisy-chain connection and only taken to ground in the central control system panel.

It is important to carefully consider the type of cable to be used. Just because a cable has the proper number of conductors and is shielded does not mean it is an acceptable cable. Frick recommends the use of Belden #9829 for RS-422 communications and Belden # 9841 for RS-485 up to 2000 feet (600 Meters) total cable length. Refer to Frick drawing 649D4743 for more detail

Comm Port Protection: Surge suppression for the comm ports may not be the best method, since suppression is required to divert excess voltage/current to ground. Therefore, the success of these devices is dependent on a good ground (covered earlier in this section). This excess energy can be quite high and without a proper ground, it will access the port and damage it.

Isolation or Optical Isolation is the preferred comm port protection method. With optical isolation, there is no continuity between the communications cable and the comm port. There is no dependence on the quality of the ground. Be sure to know what the voltage isolation value of the optical isolator is before selecting it. These may range from 500 to 4000 Volts.

Frick Optical Isolation Kits are offered under part number 639C0133G01. One kit is required per comm port.

UPS POWER AND QUANTUM™LX PANELS

Johnson Controls, Inc. does not advise nor support the use of uninterrupted power supply systems for use with the Quantum™LX panel. With a UPS system providing shutdown protection for a Quantum panel, the panel may not see the loss of the 3-phase voltage on the motor because the UPS may prevent the motor starter contactor from dropping out. With the starter contactor still energized, the compressor auxiliary will continue to feed an “okay” signal to the Quantum™LX panel. This may allow the motor to be subjected to the fault condition on the 3-phase bus.

A couple of fault scenarios are: 1. The 3-phase bus has power “on” and “off” in a continuous cycle manner which may cause the motor to overheat due to repeated excessive in-rush current experiences. 2. The motor cycling may damage the coupling or cause other mechanical damage due to the repeated high torque from rapid sequential motor “bumps.” 3. Prolonged low voltage may cause the motor to stall and possibly overheat before the motor contactor is manually turned off.

Under normal conditions, the loss of 3-phase power will shut down the Quantum™LX panel and it will reboot upon proper power return. If the panel was in “Auto,” it will come back and return to running as programmed. If the unit was in “Remote,” the external controller will re-initialize the panel and proceed to run as required. If the panel was in “Manual” mode, the compressor will have to be restarted manually after the 3-phase bus fault/interruption has been cleared / restored.

If the local power distribution system is unstable or prone to problems there are other recommendations to satisfy these problems. If power spikes or low or high line voltages are the problem, then a constant voltage (CV) transformer with a noise suppression feature is recommended. Johnson Controls, Inc. can provide these types of transformers for this purpose. Contact Johnson Controls for proper sizing (VA Rating) based on the requirement of the job. If a phase loss occurs, then you will typically get a high motor amp shutdown. If the problem continues, an analysis of the facility’s power supply quality may be necessary.

NOTE: It is very important to read the installation instructions thoroughly before beginning the project. Make sure you have drawings and instructions for the equipment being installed. If not, call the manufacturer to receive the proper instructions and drawings. Every manufacturer of electronic equipment should have a knowledgeable staff, willing to answer your questions or provide additional information. Following correct wiring procedures will ensure proper installation and consequently, proper operation of your electronic equipment.

COMPRESSOR PRESTART CHECKLIST

The following items **MUST** be checked and completed by the installer prior to the arrival of the Frick Field Service Supervisor. Details on the checklist can be found in this manual. Certain items on this checklist will be reverified by the Frick Field Service Supervisor prior to the actual start-up.

Mechanical Checks

- Confirm that motor disconnect is open
- Isolate suction pressure transducer
- Pressure test and leak check unit
- Evacuate unit
- Remove compressor drive coupling guard
- Remove coupling center and **DO NOT reinstall** (motor rotation must be checked without center)
- Check for correct position of all hand, stop, and check valves **PRIOR** to charging unit with **OIL** or **REFRIGERANT**
- Charge unit with correct type and quantity of oil
- Lubricate electric drive motor bearings **PRIOR** to checking motor rotation
- Check oil pump alignment (if applicable)
- Check for correct economizer piping (if applicable)
- Check separate source of liquid refrigerant supply (if applicable, liquid injection oil cooling)
- Check water supply for water-cooled oil cooler (if applicable, water cooled oil cooling)
- Check thermosyphon receiver refrigerant level (if applicable, thermosyphon oil cooling)
- Check for **PROPER PIPE SUPPORTS** and correct foundation
- Check to ensure **ALL** piping **INCLUDING RELIEF VALVES** is completed

Electrical Checks

- Confirm that main disconnect to motor starter and micro is open
- Confirm that electrical contractor has seen this sheet, **ALL PERTINENT WIRING** information, and drawings
- Confirm proper power supply to the starter package
- Confirm proper motor protection (breaker sizing)
- Confirm that all wiring used is stranded copper and is 14 AWG or larger (sized properly)
- Confirm all 120 volt control wiring is run in a separate conduit from all high voltage wiring
- Confirm all 120 volt control wiring is run in a separate conduit from oil pump and compressor motor wiring
- Confirm no high voltage wiring enters the micro panel at any point
- Check current transformer for correct sizing and installation
- Check all point-to-point wiring between the micro and motor starter
- Confirm all interconnections between micro, motor starter, and the system are made and are correct
- Ensure all electrical panels are free from installation debris, **METAL PARTICLES**, and moisture

After the above items have been checked and verified:

- Close the main disconnect from the main power supply to the motor starter
- Close the motor starter disconnect to energize the micro
- Manually energize oil pump and check oil pump motor rotation
- Manually energize compressor drive motor and check motor rotation
- Leave micro energized to ensure oil heaters are on and oil temperature is correct for start-up

Summary: The Frick Field Service Supervisor should arrive to find the above items completed. He should find an uncoupled compressor drive unit (to verify motor rotation and alignment) and energized oil heaters with the oil at the proper standby temperatures. Full compliance with the above items will contribute to a quick, efficient and smooth start-up.

The Start-up Supervisor will:

1. Verify position of all valves
2. Verify all wiring connections
3. Verify compressor motor rotation
4. Verify oil pump motor rotation
5. Verify the % of FLA on the micro display
6. Verify and finalize alignment (if applicable)
7. Calibrate slide valve and slide stop
8. Calibrate temperature and pressure readings
9. Correct any problem in the package
10. Instruct operation personnel

NOTE: Customer connections are to be made per the electrical diagram for the motor starter listed under the installation section and per the wiring diagram listed under the maintenance section of the IOM.

Please complete and sign this form & fax to 717-762-8624 as confirmation of completion.

Frick Sales Order Number: _____
 Compressor Model Number: _____
 Unit Serial Number: _____
 End User Name: _____
 Address of Facility: _____
 City, State, Zip: _____

Print Name: _____
 Company: _____
 Job Site Contact: _____
 Contact Phone Number: _____
 Signed: _____

Start-up Report

Frick Order No: _____

Sold To: _____ Contact Name: _____ Date: _____
 End User: _____ Contact Name: _____ Phone: _____
 End User Address: _____ Fax No: _____
 City, State, Zip: _____ Start-up Representative _____

Unit General Information

Unit Model # _____ Customer Package Identification # _____
 Compressor Serial # _____ Separator National Board # _____
 Unit Serial # _____ Oil Cooler National Board # _____
 Evaporator National Board # _____ Serial # _____ Condenser National Board # _____ Serial # _____
 Oil Pot National Board # _____ H.P. Receiver National Board # _____
 Economizer National Board # _____ Suction Accumulator National Board # _____
 Refrigerant _____ Oil Filters _____ Lube Oil Type _____ Design Operating Conditions
 Oil Cooling _____ ° Suct. / _____ ° Disch.

Micro Information

Micro Type _____ Program Software Ver # _____ and Date _____ UL Serial # _____
 Digital I/O Board #1 Serial # _____ Software Ver # _____ and Date _____
 Digital I/O Board #2 Serial # _____ Software Ver # _____ and Date _____
 Analog Board #1 Serial # _____ Software Ver # _____ and Date _____
 Analog Board #2 Serial # _____ Software Ver # _____ and Date _____

Compressor Motor Starter / Drive Information

Manufacturer _____ Part # _____ Model # _____
 Starter Type _____ Serial # _____
 Input Voltage _____ Voltage Range _____ Phase _____ Hz _____ Current _____
 Output Voltage _____ Phase _____ Hz _____ Max FLA _____ Max LRA _____ Min Load FLA _____ Job FLA _____
 Logic Board Serial # _____ U33 Prog. Ver. _____ Date _____ P/N _____
 U34 Prog. Ver. _____ Date _____ P/N _____
 U45 Prog. Ver. _____ Date _____ P/N _____
 Harmonic Filter Serial # _____ Prog. Ver. _____ Date _____ P/N _____
 Frick Interface Serial # _____ Prog. Ver. _____ Date _____ P/N _____
 CT Location Checked CT Phase _____ CT Ratio _____ Transition Time _____ DBS Ver.# _____

Oil Pump Information

Pump Mfg. _____ Model # _____ Serial # _____ Motor Mfg. _____ H.P. _____
 Motor RPM _____ Service Factor _____ Volt _____ HZ _____ FLA _____ Design _____ Code _____ Starter Size _____

Cooling Fan Information

Motor HP _____ RPM _____ Service Factor _____ Volt _____ Hz _____ FLA _____ Cooling Fans _____

Special Options

_____ _____ _____ _____

Prestart Checks

- | | | |
|---|---|---|
| <input type="checkbox"/> Installation, Foundation | <input type="checkbox"/> Compressor PHD Setup | <input type="checkbox"/> Coolant Installed |
| <input type="checkbox"/> Position of all valves | <input type="checkbox"/> Motor PHD Setup | <input type="checkbox"/> 4-20 Coolant Loop Pump Setup |
| <input type="checkbox"/> Proper oil charge | <input type="checkbox"/> Motor Winding RTD's Setup | <input type="checkbox"/> Coolant Loop Temp Setup |
| <input type="checkbox"/> All wiring connections | <input type="checkbox"/> Motor Bearing RTD's Setup | <input type="checkbox"/> Cooling Fan Motor I/O Setup |
| <input type="checkbox"/> Starter Cleanliness | <input type="checkbox"/> Motor Temperature Thermistor Setup | <input type="checkbox"/> Cooling Fan Rotation Checked |
| <input type="checkbox"/> All micro settings | <input type="checkbox"/> 4-20 Motor Drive Signal Calibrated | <input type="checkbox"/> Oil pump motor rotation |
| <input type="checkbox"/> 4-20 CT Channel 16 Setup | <input type="checkbox"/> Cold alignment | <input type="checkbox"/> Motor rotation |
| <input type="checkbox"/> 4-20 Output Calibration - Liquid Makeup Valve, Coolant Temp Valve, Economizer Makeup Valve | | |

Configuration

Capacity	Channel	Direction	Package
Mode 1 _____	_____	_____	Compressor _____
Mode 2 _____	_____	_____	Pump _____
Mode 3 _____	_____	_____	Dual Pump _____
Mode 4 _____	_____	_____	Drive _____
VFD Hi & Low PI Control	_____	_____	Refrigerant _____ K-Factor _____
Miscellaneous			Filter _____
Sequencing _____			PowerPac _____
Condenser _____			
Screen Saver _____			

Page 3

Unit Serial # _____ Frick Order No: _____

Compressor Motor Setpoints and Information

Motor Name Plate	VFD	Manufacturer _____
Motor Amps _____	Maximum Drive Output ____ %	Frame Size _____
Volts _____	Minimum Drive Output ____ %	H.P. _____
Service Factor _____	Remote Control	RPM _____
Horsepower _____	Rate Of Increase _____ % Delay ____ Sec	Serial # _____
CT Factor _____	Rate Of Decrease _____ % Delay ____ Sec	Service Factor _____
Recycle Delay _____ Min	Capacity Control	Voltage _____
High Motor Amps	When Slide Valve Reaches _____ %	Hz _____
Load Inhibit _____	Drive Speed Reaches _____ %	Design _____
Force Unload _____	Variable Speed Min. Slide Valve Position _____ %	Code _____
Warning _____ Delay ____ Sec	Skip Frequency Bands	Bearing Type _____
Shutdown _____ Delay ____ Sec	Bottom _____	Motor Coupling _____
	Top _____	

Low Motor Amps		
Shut Down _____ Delay ____ Sec		
Confirmed Running Motor Amps _____		
Starting Motor Amps Ignore Period _____ Sec		

Vyper Coolant Setpoints

Vyper Standby Time _____ Vyper Coolant Low Temp. Alarm _____ Delay _____ Shutdown _____ Delay _____
High Temp. Alarm _____ Delay _____ Shutdown _____ Delay _____

PHD Monitoring Setpoints

Compressor Bearing _____

Suction End **Delay**
High Warning _____ gF _____ Sec
High Shutdown _____ gF _____ Sec

Discharge End **Delay**
High Warning _____ gF _____ Sec
High Shutdown _____ gF _____ Sec

Motor Bearing _____

Shaft Side **Delay**
High Warning _____ F _____ Sec
High Shutdown _____ F _____ Sec

Opposite Shaft Side **Delay**
High Warning _____ F _____ Sec
High Shutdown _____ F _____ Sec

Motor Stator _____

Stator 1 **Delay**
High Warning _____ F _____ Sec
High Shutdown _____ F _____ Sec

Stator 2 **Delay**
High Warning _____ F _____ Sec
High Shutdown _____ F _____ Sec

Stator 3 **Delay**
High Warning _____ F _____ Sec
High Shutdown _____ F _____ Sec

Condenser Control

Condenser Control Setpoint _____

Digital Controls	Step Order
Module A	_____
Module B	_____
Module C	_____
Module D	_____

Step Up Dead Band _____ PSI
Step Up Delay _____ Sec
Step Down Dead Band _____ PSI
Step Down Delay _____ Sec
High Pressure Override _____ PSI
High Pressure Override Delay _____ Sec

Analog Controls Analog Output A _____
Analog Output B _____
Proportional Band _____ PSI
Integration Time _____ Sec
High Limit _____ PSI
Low Limit _____ Sec

Miscellaneous

Remote Capacity Deadband _____ %
High Compressor Oil Pressure _____
Shutdown _____ PSI Delay ____ Sec

Max Slide Valve Timer _____ 1/10 Sec
Max Discharge Pressure _____ PSI
Max Discharge and Oil Temp _____ °F

Page 4 Unit Serial # _____ Frick Order No: _____

P&ID Setpoints

Name	_____	_____	_____	_____
Control	_____	_____	_____	_____
Action	_____	_____	_____	_____
Control Point	_____	_____	_____	_____
Device Source	_____	_____	_____	_____
Device Channel	_____	_____	_____	_____
Setpoint	_____	_____	_____	_____
Dead Band	_____	_____	_____	_____
Prop. Band	_____	_____	_____	_____
Integral Gain	_____	_____	_____	_____

Communications

Compressor ID _____

Comm 1	Comm 2	Comm 3	
Baud Rate _____	Baud Rate _____	Baud Rate _____	
Data Bits _____	Data Bits _____	Data Bits _____	
Stop Bits _____	Stop Bits _____	Stop Bits _____	
Parity _____	Parity _____	Parity _____	
RS 485 Connection _____	RS 485 Connection _____	RS 485 Connection _____	
Protocol _____	Protocol _____	Protocol _____	Use Map File _____

Ethernet

IP Data	Naming Data	Protocols
Address Type _____	Host Name _____	ModBus TCP _____
IP Address _____	Work Group _____	Ethernet I/P _____
Gateway Address _____	Comments _____	Profinet _____
Subnet Mask _____		
Web Server Port _____		

VIBRATION DATA SHEET

Date: _____
End User: _____
Address: _____

Sales Order Number: _____
Installing Contractor: _____
Service Technician: _____

Equipment ID (As in Microlog): _____
Compressor Serial Number: _____
Unit Serial Number: _____
National Board Number: _____
Running Hours: _____
Manufacturer and Size of Coupling: _____
Motor Manufacturer: RAM _____
Motor Serial Number: _____
RPM: _____ Frame Size: _____ H.P. _____
Refrigerant: _____
Ambient Room Temperature: _____ °F
Operating Conditions: _____

SUCTION		DISCHARGE		OIL		SEPARATOR		Slide Valve Position	%
Press	#	Press	#	Press	#	Temp	°F	V.I. Ratio	
Temp	°F	Temp	°F	Temp	°F			F.L.A.	%

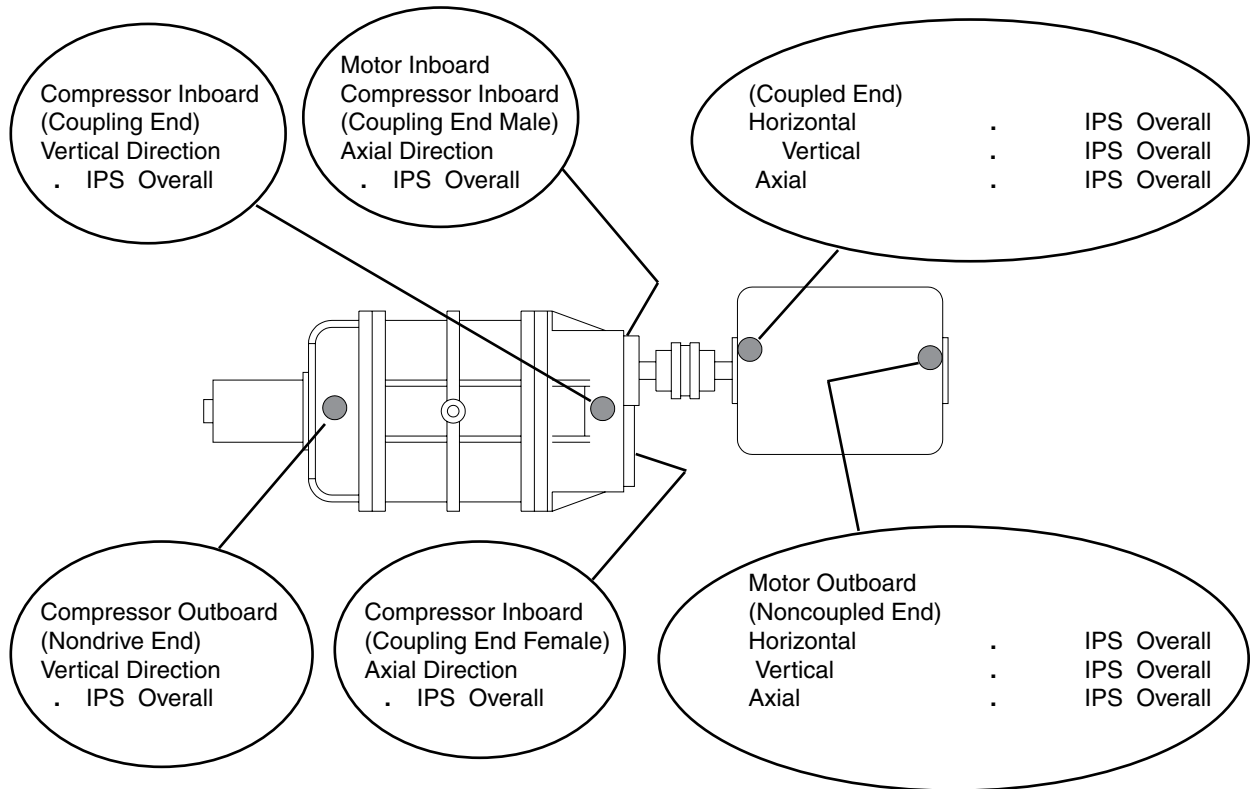

Index

Symbols

3-phase ground, 50
3-phase supply, 50

B

back flushing, 8
booster applications, 13
brownouts, 12

C

cable trays, 50
chemical cleaning process, 8
CH Coupling Data Table, 6
clamping bolts, 6
closed-loop fluids, 8
closed-loop system, 8
coalescer, 14
coalescer filter element, 7
codes, 50
cold-start valve, 13
comm port, 52
Comm Port Protection, 52
Communications, 52
Compressor
 discharge, 14
 motor, 11
compressor motor starter, 11
Compressor Port Locations - Rxf 12 -
 19, 37
Compressor Port Locations - Rxf 24 -
 50, 38
Compressor Port Locations - Rxf 58 -
 101, 39
Compressor Prestart Checklist, 54
compressor shaft, 6, 13
Compressor Unloading, 15
compressor volume ratio, 14, 15
conduit, 50
constant speed starters, 50
constant voltage (CV) transformer, 52
control power regulator, 12
cooling tower water, 8
cooling water, 8
coupling, 11
Current Transformer, 12
cutout parameters, 14

D

Daisy-chaining, 52
Demand Pump
 bearing retainer washer, 26
 bearings, 26
 bearing spacer, 26
 carbon-graphite bushing, 27
 carbon graphite bushings, 28
 Carbon Graphite Bushings, 26
 casing, 26, 28
 end clearance, 28
 head, 26
 idler, 26

idler pin, 26
locknut, 26
O-ring gasket, 27
pump, 27
pump head, 26
Pump head, 27
refrigeration oil, 27
rotor, 26, 27
rotor hub, 27
rotor shaft, 27
rotor teeth, 27
seal, 26, 27
seal housing bore, 27
seal seat, 27
seal spring, 27
snap ring, 26
spring, 26, 27
tapered installation sleeve, 27
thrust-bearing assembly, 26
Troubleshooting, 28
 Air leak, 28, 29
 alignment, 29
 cavitation, 28
 Cavitation, 29
 discharge port, 28
 Discharge Port, 29
 Discharge pressure, 29
 end clearance, 29
 Filter, 29
 foot valve, 28
 gate valve, 28
 Gate valve, 29
 head, 28
 misalignment, 28, 29
 Motor, 29
 motor speed, 29
 pressure gauge, 28
 Pressure Gauge, 29
 Pump, 29
 Pump, 28
 Rapid Wear, 29
 Relief valve, 29
 sheave size, 29
 Strainer, 29
 Suction, 28
 Suction line, 28
 suction pipe, 29
 suction port, 29
 vacuum gauge, 28
 valve, 28
 vaporizing, 29
 Vibrating, 29
differential pressure, 13
Direct Expansion Economizer System,
 10
direct motor drive, 6
double-acting solenoid valve, 16
drive hubs, 6
dry nitrogen, 6
DX economizer, 10

E

Economizer
 back-pressure regulator valve, 10
 balancing load, 11
 check valve, 10
 DX economizer, 10
 economizer port, 10
 flashing liquid, 10
 flash vessel, 10
 isolation valve, 10
 microprocessor, 10
 outlet pressure regulator, 10
 strainer, 10
 subcooling liquid, 10
elastomeric gear, 6
EMI, 50
external controller, 11
EZ-Cool™LIOC
 analog board #1, 16
 analog output #1, 16
 Control Input, 17
 Control Setpoint, 17
 Dead Band, 17
 Delta, 16
 Derivative Gain, 17
 discharge temperature, 17
 Integral Gain, 17
 Liquid Slugging, 17
 meter, 16
 operating session, 16
 P11A terminal strip, 17
 PID #1, 16
 PID Output value, 17
 Proportional Band, 17
 Proportional Gain, 17
 Quantum™LX Control Panel, 16
 terminal strip, 17

F

filter elements, 7
flexible drive coupling, 6
forklift, 6
Foundation, 5, 13
 Anchor bolts, 5
 grout, 5
 housekeeping pads, 5
 I-beams, 5
 pipe supports, 5
 reinforced concrete, 5
 vibration expert, 5

H

Handling and Moving, 5
 crane, 5
 forklift, 5
 lifting ring, 6
 rigging, 5
 spreader bars, 6
hard water conditions, 8
heat exchanger, 8

Heat-sink paste, 8
high-stage operation, 13
hydraulic system, 14

I

identification data plate, 4

J

jack, 6

L

liquid carryover, 7
liquid injection, 9, 16
 Alarms, 19
 analog input signal, 18
 Danfoss Liquid Injection Valve, 18
 digital Input signal, 18
 Display, 18
 dual dip tube method, 9
 Enter push button, 18
 high-stage units, 9
 ICAD (Industrial Control Actuator with Display), 18
 ICM valve, 18
 low condensing pressures, 9
 Mod, 18
 Motorized Industrial Control Valve, 18
 Opening Degree, 18
 parameters, 18
 Parameter list, 20
 Analog Output signal, 20
 Automatic calibration, 20
 Digital Input function, 20
 Fail-safe, 20
 ICM configuration, 20
 Main Switch, 20
 Mode, 20
 Modulating Mode, 20
 Old Alarms, 20
 Password, 20
 solenoid valve, 18
 liquid refrigerant, 16
 low voltage, 11
 lubrication system, 13

M

magnetic field, 50
main oil injection port, 14
Maintenance
 filter elements, 30
 moisture, 29
 Oil quality, 29
 Proper Installation of Electronic Equipment, 48
 refrigeration oil, 29
Maintenance, 22
 Bare Compressor Mounting, 34
 bearing failure, 22
 coalescer filter element, 25
 daily log, 29
 discharge service valve, 25
 Disconnect Power, 22

disconnect switches, 23
drain valve, 24, 25
dry nitrogen, 22
Isolation Valves, 22
isolation valves, 23
liquid injection strainer, 24
liquid injection valves, 22
liquid refrigerant, 22
low pressure transducer, 23
motor bearings, 31
 lubrication, 31
nuisance oil level cutouts, 25
oil-charging valve, 25
oil analysis testing, 29
oil cooler, 25
Oil entrained refrigerant, 23, 25
oil filters, 23
oil filter element, 25
oil foaming, 24
oil pressure loss, 25
oil pump strainer, 24
operating log, 31
Operating Log Sheet, 53
pressure sensors, 34
Pressure Transducers, 32
 Conversion Data, 32
 Replacement, 33
 Testing, 32
P & I Diagram, 40
refrigerant vapor, 23, 25
Safety Equipment, 22
service valves, 23
solenoid valves, 23
spin-on oil filter element, 23
starting torque, 24
strainer elements, 25
strainer service valves, 24
suction check valve bypass, 23, 25
suction service valve, 25
suction strainer, 22
suction valve bypass, 24
superheat, 22
Troubleshooting. *See Index, Troubleshooting*
Ventilation, 22
vibration analysis, 29
Vibration Data Sheet, 59
vibration level, 22
water vapor, 22
Wiring Harness, 47
Maintenance
 DIN connector plug, 33
 linear transmitter, 33
 Maintenance Schedule, 30
 oil level control, 34
 Oil Level Transmitter, 34
 sensor well, 33
 temperature sensor, 33
 Temperature Transmitter, 34
 volume ratio control, 33
metal conduit, 50
microprocessor, 10, 16
moments, 9

motor, 11
motor contactor, 11
Motor cycling, 11
motor rotation, 6, 13
motor starter contactor, 11
mounting bolts, 6
movable slide valve, 14
Multiple Compressor Economizer System, 10

N

neoprene drive spacer, 6
noise suppression, 52

O

oil charge reservoir, 14
oil charging valve, 7
Oil distillers, 7
oil filter, 7
oil foaming, 29
oil heaters, 7
oil leakage, 29
oil level cutout, 29
oil pressure loss, 29
operating volume ratio, 16
Optical Isolation, 52

P

pH, 8
power feed, 50
power fluctuations, 12
pressure differential, 14
PVC-coated metallic, 50
PVC conduit, 50

Q

Quantum™ LX, 11
Quantum™LX, 14, 52
Quantum™ LX control system, 11
Quantum™ panel, 11

R

reboot, 52
recovery procedure, 25
RXF rotary screw compressor, 13
 Moveable slide valve, 13
 shaft seal, 13

S

SBC Board, 11
scaling, 8
self-lubricating, 13
separator, 6
serial number, 4
severe water conditions, 8
Shell And Coil Economizer System, 10
shipping gauges, 7
shutdown, 22
 liquid injection, 22
 package valves, 22
 solenoid valves, 22
 strainers, 22

sight glass, 7, 14
signal wiring, 50
single-port liquid injection, 16
slide stop, 21
slide valve, 21
slide valve piston, 14
Sola® constant voltage (CV) transformer, 11
solenoid valve, 16
Star Networks, 52
start-up, 21
 slide valve potentiometer, 21
 suction strainer, 21
starter package wiring diagram, 12
static forces, 9
strainer, 8, 25
stub connections, 8
suction check valve bypass, 14, 25
suction housing, 6, 13
Surge suppression, 52

T

temperature sensor, 16
Thermosyphon oil cooling, 21
 condensing pressure, 21
 refrigerant-side safety valve, 7
 vapor mixture, 21
Thermosyphon Oil Cooling, 16
Thermosyphon oil cooling, 7
 drain valve, 8
 liquid refrigerant, 7
 thermostatically controlled mixing valve, 7
Welding, 8
threaded metallic, 50
threaded PVC-coated metallic, 50
Troubleshooting, 35
 Excessive Noise And Vibration, 35
 High Oil Temperature, 36
 Low Oil Temperature, 36
 Oil Temperature Fluctuates, 36
 Rapid Oil Loss, 35
 Slide Valve, 36

U

uninterrupted power supply, 52
Unit Data Plate, 3
unshielded, 50
UPS, 11, 52
UPS Power, 52
UPS power system, 11

V

variable frequency drives, 50
vessel, 21
VFD Applications, 49
VFD output, 49
VIBRATION DATA SHEET, 59
voltage isolation, 52

W

Water-Cooled Oil Cooling, 16
water-cooled oil coolers, 16
water treatment, 8
welding, 8

Q-NET™ network technology...

Connect Your PC
with QUANTUM™LX!

*Take full advantage of Q-NET™
technology with all Frick products!*

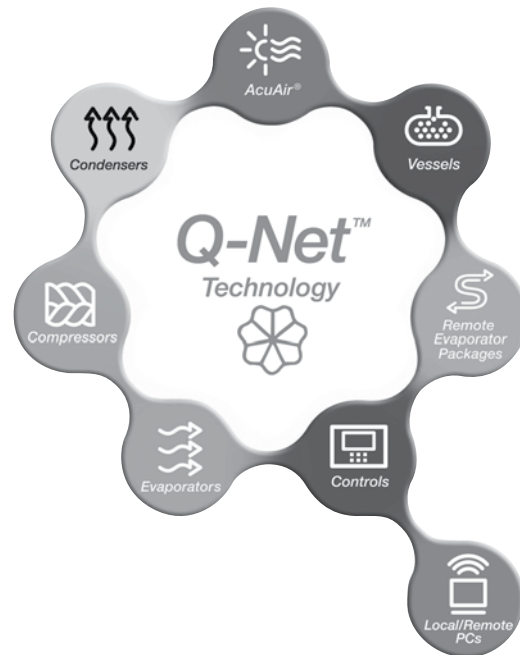

System integration is what we do...

- Q-NET™... supports open-protocols for SCADA systems (i.e. Allen-Bradley® DF1, Modbus RTU, Modbus ASCII, and Industrial Ethernet Protocols)
- Q-NET™... connects instantly for local or remote access; no software required
- Q-NET™... can be applied to both new and existing systems
- Q-NET™ means precise control 24 hours a day, seven days a week
- Q-NET™ distributed architecture mean faster, easier, economical installations
- Q-NET™ delivers increased operating efficiency and lowers energy costs

Available on Frick screw compressors, condensers, evaporators, AcuAir® hygienic air handlers, and refrigerant vessels.