

## Specifications - Engineering Data - Dimensions Installation - Operation - Maintenance

### HAND EXPANSION VALVES

**Hand Expansion Valves** are ideal for metering or flash expansion of liquid refrigerants. The slotted-plug design is more tolerant of dirt particles than standard, tapered, plug-type valves. All valves have teflon seals for tight shutoff and near-linear flow characteristics per turn open. Bar handles or yellow seal caps distinguish them from shutoff valves. Hand Expansion Valves are available in globe configuration with socket weld (1/2 in. through 2 in.) and threaded (1/2 in. through 1-1/4 in.) connections.

#### MATERIAL SPECIFICATIONS

**Body:** Threaded 1/2 in. through 1-1/4 in. ductile iron, ASTM A536; socket weld 1/2 in. and 3/4 in. ASTM A-108 (connections A-513); socket weld 1 in. through 2 in. cast steel, ASTM A-352 grade LCB.

**Bonnet:** 1/2 in. through 1-1/4 in. (threaded), zinc chromate-plated steel, 1-1/2 in. through 2 in. ductile iron, ASTM A-536 (bolted).

**Stem:** Stainless steel.

**Throttling plug:** 1/2 in. through 1-1/4 in. stainless steel, 1-1/2 in. through 2 in. zinc chromate-plated steel.

**Seat disc:** PTFE Teflon.

**Stem-sealing packing:** Graphite composite packing and neoprene O-ring.

**Packing nut:** Zinc chromate-plated carbon steel.

**Bonnet seal:** 1/2 in. through 1-1/4 in. neoprene O-ring, 1-1/2 in. through 2 in. nonasbestos, graphite and neoprene composite gasket.

#### APPLICATION

Ammonia, halocarbons, hydrocarbons, and other inert gases.\*

Sizes: 1/2 in. through 1-1/2 in. schedule 80 pipe and 2 in. schedule 40 pipe (socket weld), 1/2 in. through 1-1/4 in. (threaded).

Design working pressure of 400 PSIG and a temperature range of -60°F to 240°F. Temperatures below -50°F at reduced pressures.

\*Consult Frick Company for compatibility details.

#### INSTALLATION

Hand expansion valves should be installed with stems positioned horizontally or vertically. Liquid makeup valves

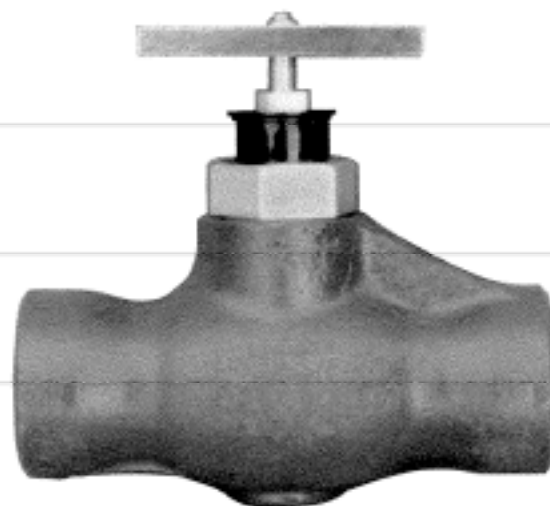

should be installed within two feet of the upstream solenoid valve. Pressure drop should occur across the expansion valve, not the control valve.

#### VALVE OPERATION and SERVICE

Hand expansion valves provide positive shutoff with hand tightening. Do not apply a wrench as it may result in plug, stem, or handwheel damage.

The stem packing and O-ring can be replaced with the valve in service under system pressure. Open the valve until firmly backseated, then remove the handwheel and packing nut for access to the packing.

Valve throttling plugs can be replaced. On 1/2 in. through 1-1/4 in. valves, open the valve a minimum of one turn, then isolate the valve from the system and pump out the refrigerant. Remove the bonnet assembly using an 18 in. wrench. The throttling plug can be replaced by removing the ball retainer ring and ball bearings. Install a new throttling plug assembly with new ball bearings and retainer ring. Install a new stem packing, stem O-ring, and bonnet O-ring if required. Reassemble the bonnet into the valve body making certain the stem is opened several turns. Tighten the bonnet to 75 foot-pounds and test for leaks. Use the same procedure for 1-1/2 in. through 2 in. valves except for tightening the bonnet. Tighten the bonnet bolts to 40 foot-pounds of torque.

**CAPACITIES (tons of refrigeration)**

| REFRIG. | APPLICATION       | 1/2" |      | 3/4" |     | 1"  |     | 1-1/4" |     | 1-1/2" |     | 2"   |     |
|---------|-------------------|------|------|------|-----|-----|-----|--------|-----|--------|-----|------|-----|
|         |                   | min  | max  | min  | max | min | max | min    | max | min    | max | min  | max |
| R717    | Circulating (4:1) | 1.5  | 16.7 | 1.5  | 37  | 1.5 | 62  | 1.5    | 110 | 9.1    | 151 | 18.2 | 253 |
|         | Liquid Makeup     | 7.4  | 60   | 7.4  | 111 | 7.4 | 185 | 7.4    | 330 | 44     | 454 | 89   | 759 |
| R22     | Circulating (2:1) | .7   | 8    | .7   | 18  | .7  | 29  | .7     | 52  | 4.4    | 72  | 8.7  | 121 |
|         | Liquid Makeup     | 1.6  | 12.5 | 1.6  | 23  | 1.6 | 38  | 1.6    | 68  | 9.8    | 94  | 19.7 | 157 |

**VALVE SIZING**

The Capacities table is based on a velocity limiting factor of 7 feet per second for R717 and 5 feet per second for R22. The circulating capacities assume a 0°F evaporator-temperature liquid with a 10 psi pressure drop across the expansion valve. Liquid makeup capacities are based on 86°F condensing to 0°F evaporation temperature. Maximum capacities are possible with appropriate line sizing. For liquid feed to an accumulator, the valve should be sized for intermittent feed, switch-operated flow (i.e. a valve open 50% of the time feeding a 100 ton accumulator should be sized for 200 tons). For liquid makeup, when the valve size is greater than 1-1/2 in., two expansion valves and solenoid valves staged in parallel should be used to reduce the potential of "water hammer".

Valve sizing may also be calculated using the valve setting instructions. Valve sizes are normally based on the valve in the half-open position.

**VALVE SETTING**

To properly set Hand Expansion Valves, the following factors must be known: refrigerant temperature, estimated pressure drop across the expansion valve (not the system), evaporator tonnage, and circulating rate or desired liquid makeup.

For circulating liquid overfeed, the following steps determine the flow (Cv) requirement and the required turns open:

1. Evaporator tons multiplied by circulating rate = **ton equivalent** = \_\_\_\_\_
2. See table below - **tons per Cv** = \_\_\_\_\_
3. **Ton equivalent** divided by **tons per Cv** = **Cv requirement** = \_\_\_\_\_
4. See Cv per Turns Open Table , valve size versus Cv requirement = **turns open** = \_\_\_\_\_

**Tons per Cv(circulating liquid overfeed)**

| REFRIG. | TEMP °F | PRESSURE DROP (ΔP)* |      |      |      |       |
|---------|---------|---------------------|------|------|------|-------|
|         |         | 5                   | 10   | 15   | 20   | 30    |
| R717    | 0       | 43.0                | 60.8 | 74.5 | 86.1 | 105.5 |
| R22     | 0       | 10.0                | 14.5 | 17.5 | 20.2 | 24.8  |

\*Pressure drop across expansion valve.

For other evaporator temperatures, these values will change only slightly due to density and latent heat variations.

For liquid makeup, determine the flow (Cv) requirement, estimate the approximate tons of liquid makeup desired, and divide by 74.2 tons per Cv for ammonia or 16.4 tons per Cv for R22. These ratings are based upon 86°F saturated liquid with 50 psi pressure drop across the valve and 0°F evaporating temperature. Refer to Cv per Turns Open table for the appropriate valve setting.

**Cv per TURNS OPEN**

| SIZE (in.)                           | TURNS OPEN |     |     |      |      |      |      |      |     |
|--------------------------------------|------------|-----|-----|------|------|------|------|------|-----|
|                                      | 1          | 2   | 3   | 4    | 5    | 6    | 7    | 7.5  |     |
| T<br>H<br>R<br>E<br>A<br>D<br>E<br>D | 1/2        | .1  | .3  | .6   | .9   | 1.1  | -    | -    | -   |
|                                      | 3/4        | .1  | .8  | 1.5  | 2.2  | 2.9  | -    | -    | -   |
|                                      | 1          | .1  | .3  | .6   | 1.2  | 2.2  | 3.3  | 4.2  | 4.5 |
|                                      | 1-1/4      | .1  | .3  | .9   | 2.0  | 4.0  | 5.8  | 7.0  | 7.4 |
| W<br>E<br>L<br>D<br>E<br>D           | 1/2        | .1  | .2  | .3   | .4   | .6   | .8   | .9   | 1.1 |
|                                      | 3/4        | .1  | .2  | .5   | .9   | 1.4  | 2.0  | 2.6  | 2.9 |
|                                      | 1          | .1  | .3  | .6   | 1.2  | 2.2  | 3.3  | 4.2  | 4.5 |
|                                      | 1-1/4      | .1  | .3  | .9   | 2.0  | 4.0  | 5.8  | 7.0  | 7.4 |
|                                      | 1-1/2      | .6  | 1.5 | 4.5  | 7.0  | 10.0 | 13.5 | 15.0 | -   |
| 2                                    | 1.2        | 4.0 | 7.5 | 11.0 | 14.5 | 18.0 | 22.0 | -    |     |

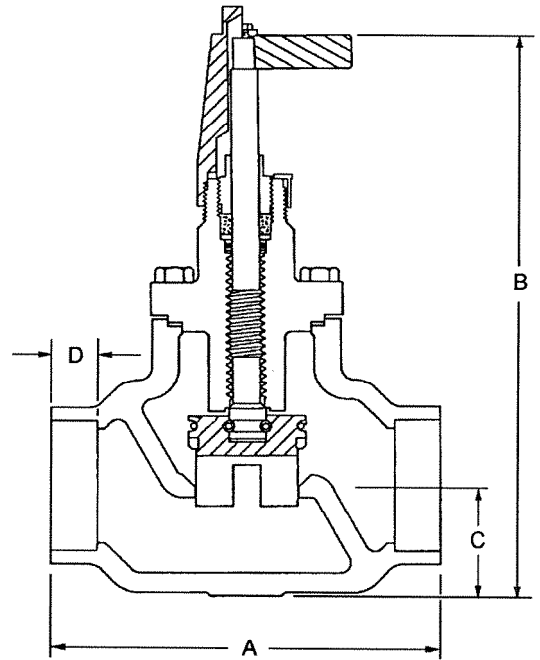
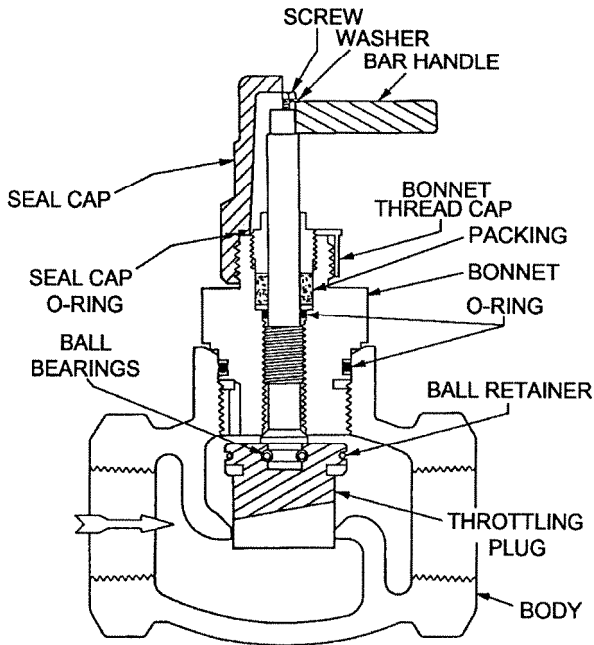

**THREADED ENDS  
THREADED BONNET**

**SOCKET WELD ENDS  
BOLTED BONNET**

| THREADED - GLOBE |                              |             |                        |         |       |       |           |
|------------------|------------------------------|-------------|------------------------|---------|-------|-------|-----------|
| SIZE (in.)       | STOCK NUMBER/<br>PART NUMBER |             | VALVE DIMENSIONS (in.) |         |       |       | WT. (lb.) |
|                  | HANDWHEEL                    | SEALCAP     | A                      | B       |       | C     |           |
|                  |                              |             |                        | HW OPEN | SC    |       |           |
| 1/2              | 452221                       | 452225      | 3-5/8                  | 5-3/4   | 6     | 1     | 3         |
|                  | 954A0022H01                  | 954A0023H01 |                        |         |       |       |           |
| 3/4              | 452222                       | 452226      | 3-5/8                  | 5-3/4   | 6     | 1     | 3         |
|                  | 954A0022H02                  | 954A0023H02 |                        |         |       |       |           |
| 1                | 452223                       | 452227      | 4-1/2                  | 6-1/2   | 6-3/4 | 1-1/2 | 4         |
|                  | 954A0022H03                  | 954A0027H03 |                        |         |       |       |           |
| 1-1/4            | 452224                       | 452228      | 4-1/2                  | 6-1/2   | 6-3/4 | 1-1/2 | 4         |
|                  | 954A0022H04                  | 954A0023H04 |                        |         |       |       |           |

| SOCKET WELD GLOBE |                              |             |                        |         |        |       |     |           |
|-------------------|------------------------------|-------------|------------------------|---------|--------|-------|-----|-----------|
| SIZE (in.)        | STOCK NUMBER/<br>PART NUMBER |             | VALVE DIMENSIONS (in.) |         |        |       |     | WT. (lb.) |
|                   | HANDWHEEL                    | SEALCAP     | A                      | B       |        | C     | D   |           |
|                   |                              |             |                        | HW OPEN | SC     |       |     |           |
| 1/2               | 453212                       | 453215      | 5-1/2                  | 6       | 6-1/4  | 1-1/8 | 1/2 | 4         |
|                   | 955A0006H01                  | 955A0007H01 |                        |         |        |       |     |           |
| 3/4               | 453213                       | 453216      | 5-1/2                  | 6       | 6-1/4  | 1-1/8 | 1/2 | 4         |
|                   | 955A0006H02                  | 955A0007H02 |                        |         |        |       |     |           |
| 1                 | 452624                       | 453217      | 6-1/2                  | 6-1/2   | 6-3/4  | 1-1/2 | 1/2 | 7         |
|                   | 955A0006H03                  | 955A0007H03 |                        |         |        |       |     |           |
| 1-1/4             | 453214                       | 453218      | 6-1/2                  | 6-1/2   | 6-3/4  | 1-1/2 | 5/8 | 7         |
|                   | 955A0006H04                  | 955A0007H04 |                        |         |        |       |     |           |
| 1-1/2             | 453043                       | 453219      | 7-1/2                  | 11      | 11-1/4 | 2-1/8 | 5/8 | 18        |
|                   | 955A0006H05                  | 955A0007H05 |                        |         |        |       |     |           |
| 2                 | 453044                       | 453220      | 7-1/2                  | 11      | 11-1/4 | 2-1/8 | 7/8 | 19        |
|                   | 955A0006H06                  | 955A0007H06 |                        |         |        |       |     |           |



100 CV Avenue, P.O. Box 997 Waynesboro, Pennsylvania USA 17268-0997  
Phone: 717-762-2121 • Fax: 717-762-8624