

HORIZONTAL OIL POTS

Carbon Steel - Stainless Steel

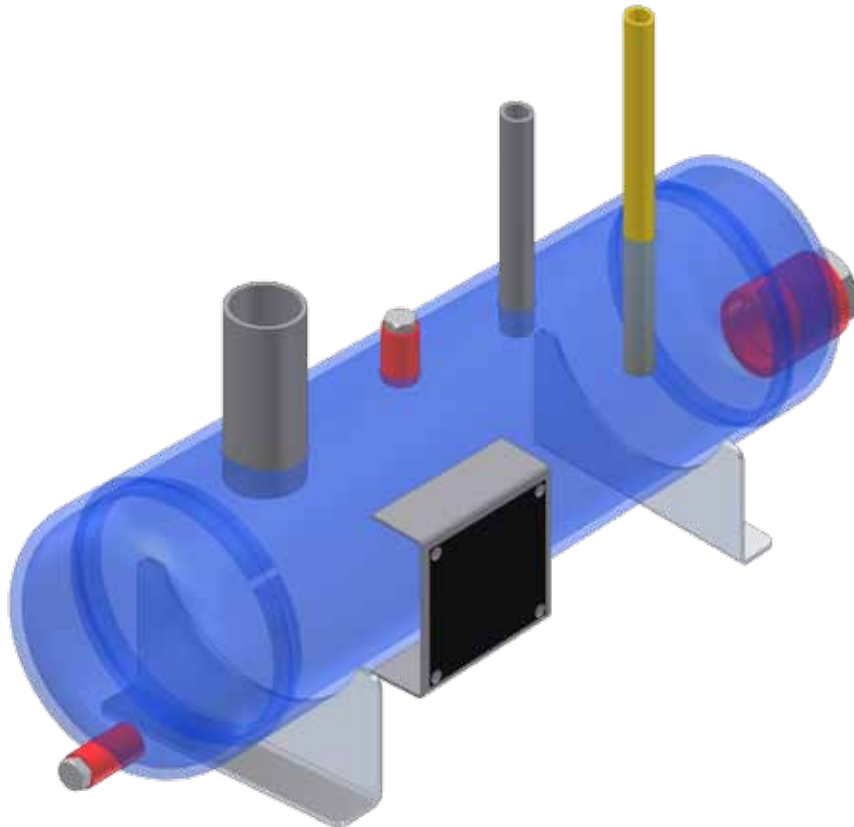

DESCRIPTION

Frick Oil Pots are small diameter ASME certified pressure vessels that collect a mixture of refrigerant and oil that can accumulate at various points in a refrigeration system. This single collection point facilitates the separation of the refrigerant from the oil and the removal of the oil from the oil pot.

FEATURES

CARBON STEEL	STAINLESS STEEL
ASME, BPV code certified	
450 psi maximum allowable working pressure at 250°F	
-55°F minimum design metal temperature at 450 psi	-155°F minimum design metal temperature at 450 psi
Integral steel saddle supports	Integral stainless steel saddle supports
High quality corrosion inhibiting paint	High quality paint system
Optional (ship loose) immersion heater with thermostat for low temperature applications	
Nozzles A, C, and D have slight internal projection to vapor space at relief device	

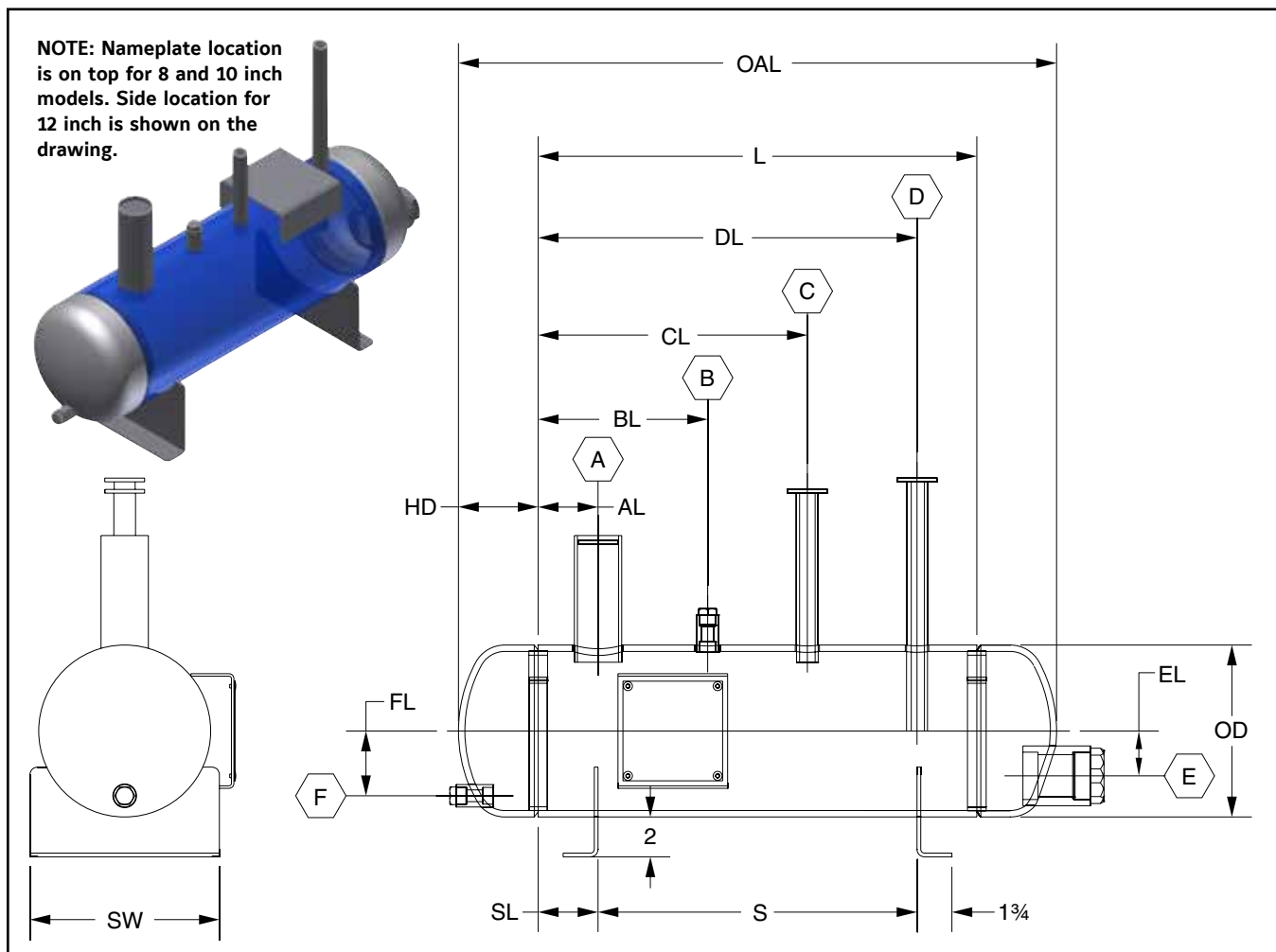
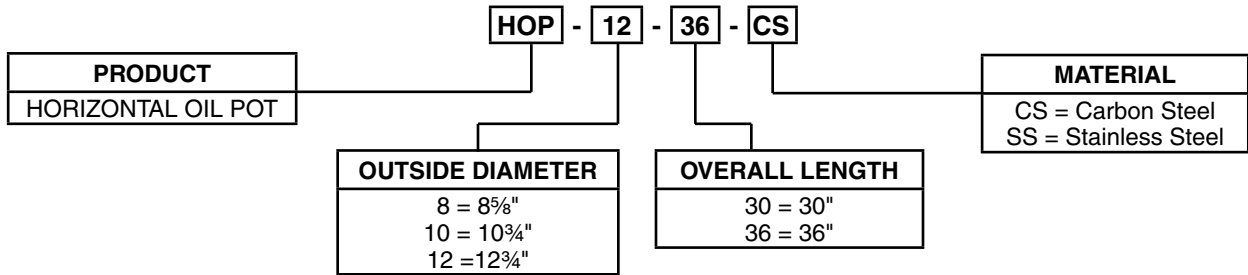

Figure 1. Data and Dimensions (Carbon Steel and Stainless Steel)

Key to Nozzle/Coupling Descriptions		
A - Inlet	F - Drain (Coupling)	OAL - Overall Length
B - Relief (Coupling)	HD - Head Depth	S - Saddle Separation
C - Vent	L - Shell Length	SL - Left Saddle
D - Oil Outlet	OD - Outside Diameter	SW - Saddle Width
E - Heater Connection/Spare (Coupling)		

NOMENCLATURE



R-717 Oil Pots

MODEL NUMBER*	MAWP (psig)	VESSEL		L	HD ⁽⁶⁾	Dry Weight (lbm)	VOLUME ^(2,6) (ft ³)	R-717 ⁽³⁾ (lbm)
		OD (in)	OAL (in) ⁽⁶⁾					
HOP-8-30-xx	450	8 ⁵ / ₈	30	22	4.00	100	0.8	26.0
HOP-10-36-xx	450	10 ³ / ₄	36	26	5.00	150	1.4	47.0
HOP-12-36-xx	450	12 ³ / ₄	36	24	6.00	180	2.0	64.0

MODEL NUMBER*	NOZZLE / CPLG ⁽⁴⁾⁽⁵⁾ NPS						NOZZLE LOCATIONS						S	SL	SW
	A	B	C	D	E	F	AL	BL	CL	DL	EL	FL			
HOP-8-30-xx	2	1/2	3/4	3/4	2	1/2	3	8 ¹ / ₂	13 ¹ / ₂	19	2 ¹ / ₄	3 ¹ / ₄	16	3	9 ¹ / ₂
HOP-10-36-xx	2	1/2	3/4	3/4	2	1/2	3	9 ¹ / ₂	16 ¹ / ₂	23	3 ¹ / ₄	4 ¹ / ₄	18	4	11 ⁵ / ₁₆
HOP-12-36-xx	2	1/2	3/4	3/4	2	1/2	3	9 ¹ / ₂	15 ¹ / ₂	21	4 ¹ / ₄	5 ¹ / ₄	17	3.5	13 ¹ / ₁₆

* xx = CS or SS material.

NOTES:

- All dimensions and nozzle nominal pipe sizes are given in inches unless noted otherwise.
- Volume is given in total cubic feet of vessel.
- R-717 volume estimated by using 80% total capacity filled with ammonia having a density of 41.3654 lbm/cu-ft (0°F).
- Nozzle connections are supplied as pipe stubs unless otherwise specified as a coupling (Cplg).
- Couplings are ASME B16.11 Class 3000 "full" couplings.
- HD dimensions are for CS models that use ASME B16.9 pipe caps. Stainless steel models use 2:1 ellipsoidal heads, have slightly smaller HD dimensions and thus slightly shorter overall vessel lengths.
- Saddle base plates are provided without holes.
- All dimensions are subject to change; please consult factory for certified drawings.
- Vessels are built in accordance with ASME Boiler and Pressure Vessel Code, Section VIII, Division 1.

OIL POT HEATER OPTIONS		
kW	ELECTRICAL ENCLOSURE TYPE	VOLTAGE
2	NEMA 1	120
2	NEMA 1	240
2	NEMA 4/7	120
2	NEMA 4/7	240
2	NEMA 4/7	480
1	NEMA 4/7	120
1	NEMA 4/7	240
1	NEMA 4/7	480
1.5	NEMA 4/7	120
1.5	NEMA 4/7	240
1.5	NEMA 4/7	480

