



BY JOHNSON CONTROLS

Form 070.251-SM (JAN 2007)

**SERVICE MANUAL**

File: SERVICE MANUAL - Section 70  
Replaces: 070-251 SM (JAN 2007)  
Dist: 3, 3a, 3b, 3c  
Revised: 9/22/09 p. 10

**Service Instructions  
Shaft Seal Replacement Kit**

**TDSH / GDSH**

Also RDB, RWF, RXB, RXF

**ROTARY SCREW COMPRESSORS**

**MODELS: 163, 193, 233, 283, 355**

**THIS MANUAL PROVIDES INFORMATION NEEDED BY QUALIFIED PERSONNEL TO REPLACE THE SHAFT SEAL ASSEMBLY. SHAFT SEAL KIT COMPONENTS ARE LISTED ON PAGE 10.**

It is recommended that prior to replacing the shaft seal, a thrust clearance measurement be conducted on the male rotor to determine the axial (in and out) movement. An increase from the design specification in the axial movement of the rotor can result in excessive oil leakage from the shaft seal. The specifications for the axial measurements with the seal housing cover removed are shown below.



**DO NOT APPLY FORCE TO THE ROTOR SHAFT OR JACK SHAFT IN THE RADIAL (UP AND DOWN) DIRECTION AS THIS WILL RESULT IN DAMAGE TO THE BEARINGS.**

pling securely to the shaft.

- Use a dial indicator graduated to measure between .001" to .0005". The indicator can be attached to a magnetic base as shown in Figure 1. The indicator can also be attached to a clamping device mounted on the motor coupling half.



**IF A CLAMP STYLE MOUNT IS USED, FORCE CANNOT BE APPLIED TO THE MOTOR COUPLING END AS THIS WILL DEFLECT THE COUPLING AND RESULT IN AN INACCURATE READING.**

- The plunger of the indicator must be against the end of the rotor shaft. Position the plunger mid-throw to ensure the plunger has adequate travel. It will be necessary to have someone read the indicator (with an inspection mirror) while the clearance is being measured.
- Insert the prying device between the compressor and compressor coupling. Move the coupling towards the motor and adjust the indicator to zero. When releasing the pressure from the coupling, the indicator may move off zero, DO NOT

TDS / RDB / RWF UNITS			
Unit Model	Comp Rotor Size	Measurements in Inch	Measurements in mm
RWBII 60 - 76	163mm	.0065 - .009	0.1651 - 0.243
RWBII /RDB/ RWF 100 - 134	193mm	.0065 - .009	0.1651 - 0.243
RWBII /RDB/ RWF 177, 222, 270	233mm	.0075 - .0105	0.1905 - 0.2667
RWBII / RDB/ RWF 316, 399, 546	283mm	.008 - .012	0.2032 - 0.2794
*All TDSH & SGCH 355 designs	355mm	.010 - .012	0.2540 - 0.3048
*All TDSB & SGCB 355 designs	355mm	.007 - .012	0.1778 - 0.3048

\* Identify by COMPRESSOR serial number.

**RWBII, RDB, RWF UNITS**

**THRUST CLEARANCE PROCEDURE:**

The DISCHARGE END CLEARANCE measurement records the overall rotor to discharge housing clearance. Pressure must be removed from the unit prior to conducting the reading. This reading is conducted with the seal housing cover and spring washer removed.



**WEAR PROPER SAFETY EQUIPMENT AND TAKE NECESSARY SAFETY PRECAUTIONS REQUIRED FOR THIS PROCEDURE.**

- Evacuate unit (refer to S70-200/210 or S70-300/301 IOM)
- Lockout and tag motor.
- Remove coupling guard and center hub of the coupling.
- Position the compressor coupling-half in order to fit a prying device between the coupling-half and compressor, see Figure 2. A board 2" x 4" x 24" works well for this procedure. The rotor needs to extend past the coupling to ensure good contact with the indicator plunger. Tighten the coupling securely to the shaft.
- Position the motor coupling half in order to fit the prying device between the two coupling halves. Tighten the cou-

**RESET INDICATOR.**

- Insert the prying device between the couplings and push the compressor coupling towards the compressor. Record movement. Care should be taken not to turn the rotor. If a clamping mount is used, the motor coupling half cannot be used to pry against the compressor coupling. Insert the end of the pry bar against something solid in order to push against the compressor coupling. Once the rotor is pushed towards the compressor record indicator reading. This reading will be the discharge end clearance.

**RXB & RXF UNITS**

The procedure to measure the axial thrust clearance on the RXB and RXF units is similar to the procedure for the RWBII/RDB & RWF units. The one difference is that on the RXB and RXF units the thrust clearance is measured on the Jack Shaft (shaft coupled to motor) not on the rotor.

- The seal housing must remain mounted to the compressor to conduct measurement.
- Follow steps 1 through 9 in RWBII/RDB/RWF procedure.
- The clearance specification on all RXB and RXF units is .001" to .005" (0.0254mm - 0.127mm)



- Do not apply force on the jack shaft in the radial (up and down) direction as this will result in damage to the bearings.

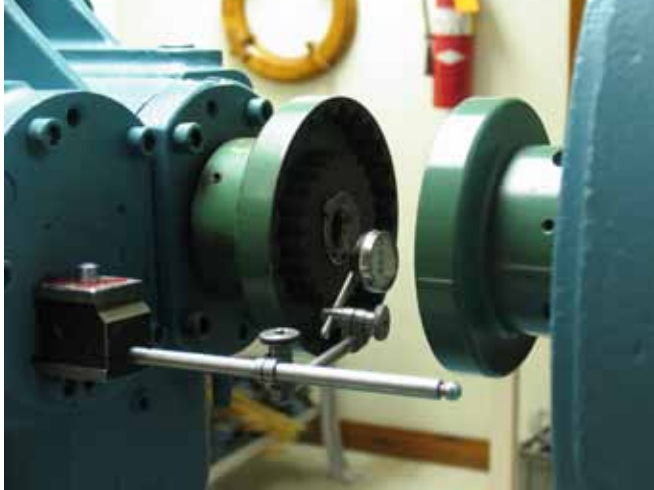

**Figure 1**  
Indicator is attached to a magnetic base.  
Plunger of indicator is positioned on rotor face.



**Figure 3**  
Board is positioned between both couplings  
to force the rotor towards the compressor.



**Figure 2**  
Board is positioned between the compressor  
and coupling to force the rotor towards the motor.

THIS MANUAL PROVIDES INFORMATION NEEDED BY QUALIFIED PERSONNEL TO REPLACE THE SHAFT SEAL ASSEMBLY. SHAFT SEAL KIT COMPONENTS ARE LISTED ON PAGE 10.

- Loosen socket-head capscrews (1) on seal housing cover (2) and remove, along with spring washer (3). See Figure 2.
- Using a seal removal tool as shown, remove seal housing spacer (4). See Figure 3 and 4.

**MODELS 163-283 SHAFT SEAL REMOVAL**

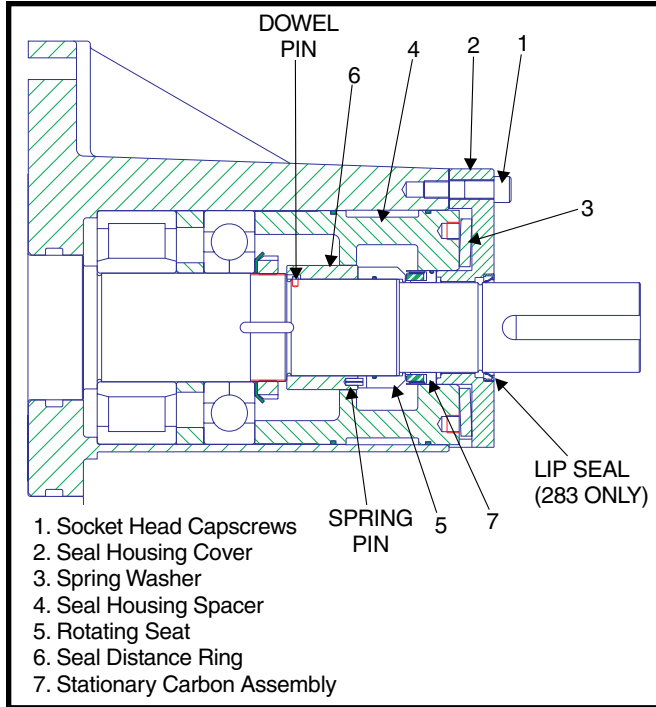

Figure 1. 163-283



**WEAR PROPER SAFETY EQUIPMENT AND TAKE NECESSARY SAFETY PRECAUTIONS REQUIRED FOR THESE PROCEDURES.**

- Evacuate compressor and oil separator (refer to S70-200/210 IOM or S70-300/301 IOM).
- Remove drive coupling.

**NOTE: Make provisions to catch residual oil that will drain when seal housing cover and spacer is removed.**



Figure 3.



Figure 4.

- Remove rotating seat (5). This is *half* of the shaft seal assembly. See Figure 5.



Figure 2.

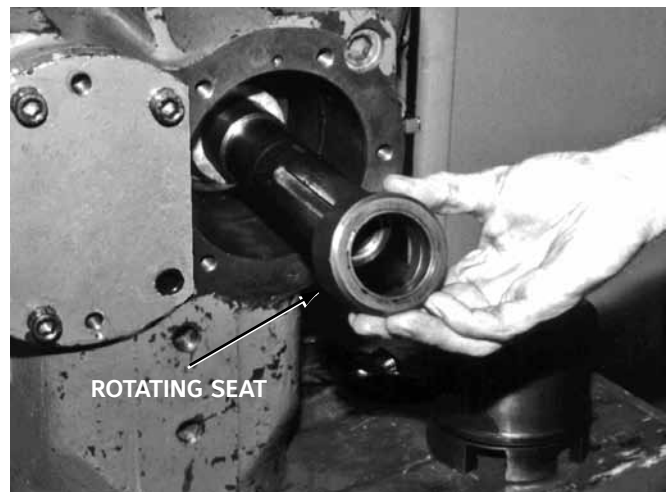
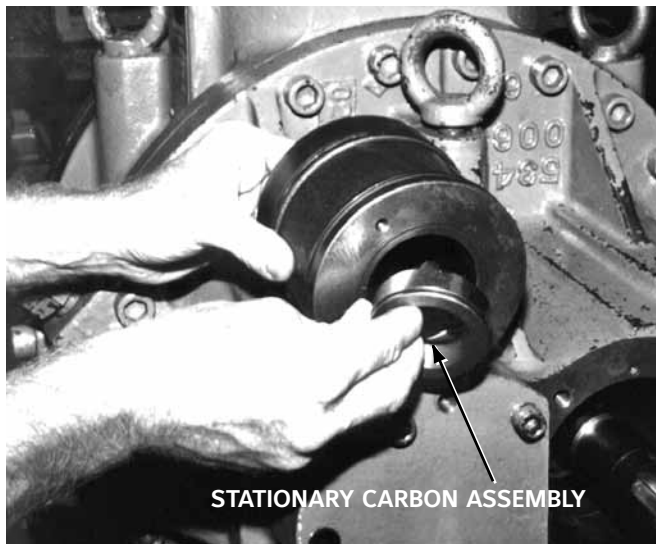

Figure 5.



**Figure 6.**

6. Remove seal distance ring (6). See Figure 6.



**Figure 7.**

7. Remove stationary carbon assembly (7) from seal housing spacer. This is the *other half* of the shaft seal assembly. See Figure 7.
8. Remove O-rings from seal housing spacer (4).

### MODELS 163–283 SHAFT SEAL INSTALLATION

1. Thoroughly clean all removed parts and casing area. Coat with clean refrigerant oil.

**NOTE: Ensure orifice (oil feed hole inside seal housing spacer (4)) is clear of obstructions.**

2. Clean shaft; polish minor scratches with fine emery cloth. Ensure keyway edges are free of burrs. Wipe clean and coat shaft with clean refrigerant oil.

**NOTE: Do not use grease on seal parts.**

3. Reinstall seal distance ring (6), making sure that slot on ring mates with pin on shaft. Rotate ring to ensure pin is engaged in slot.



**AVOID DAMAGE TO STATIONARY CARBON ASSEMBLY AND ROTATING SEAT. DO NOT TOUCH SEALING SURFACES. ENSURE CARBON IS NOT CHIPPED OR CRACKED.**

4. Submerge new rotating seat (5) in clean refrigerant oil (do not touch sealing surfaces). Slide on shaft, inserting spring pin on seal distance ring into slot at back of rotating seat.

**NOTE: Verify pin-to-slot engagement using inspection mirror and flashlight. The seal distance ring must fit flat against rotating seat. Refer to Fig. 1.**



**Figure 8.**

5. Make sure seal housing spacer (4) is lubricated with clean refrigerant oil. Coat new O-rings with clean refrigerant oil and install them on spacer. See Figure 8.

**NOTE: Use O-rings which come with seal kit. If other O-ring are used, consult Service Department.**

6. Install seal housing spacer ensuring that match marks line up at 12 o'clock. Match marks are pinholes in spacer and casing, used in models 163–233. In the model 283, a roll pin in the spacer, lines up with a groove in the casing.



SHAFT SEAL COVER AS TOOL TO  
INSTALL SEAL HOUSING SPACER

Figure 9.

7. Reverse cover (2) and using two bolts (1), tighten to finish installing seal housing spacer. Bolts should be snug, do not overtighten. When bolts are snug, seal housing spacer is not flush, it sticks out 1/8 in. See Figure 9. Remove cover.
8. Submerge new stationary carbon assembly (7) in clean refrigerant oil. Place on shaft taking care not to damage carbon. Insert in seal housing spacer by pushing with thumbs until the seal is 1/4 inch below surface.

**NOTE:** Do not use a pounding force on the seal to install. The force should be evenly supplied.



SPRING WASHER

SEAL HOUSING COVER

Figure 10.

9. Insert spring washer (3) into seal housing cover (2). The cone faces up, applying the load to the I.D. of spacer and O.D. of cover. See Figure 10.
10. Secure seal housing cover to casing with socket head capscrews. Models 163–233 use M12 capscrews. Model 283 uses M16 capscrews. Tighten capscrews evenly using a crisscross pattern to a torque value of 70 ft lb (95 Nm) for models 163–233, and 165 ft lb (225 Nm) for model 283.

**Note:** Later model 283 compressors will have an oil seal pressed into the housing cover. This is not included in the shaft seal kit and usually does not need replacement.

11. Reinstall coupling.

MODEL 355 SHAFT SEAL REMOVAL

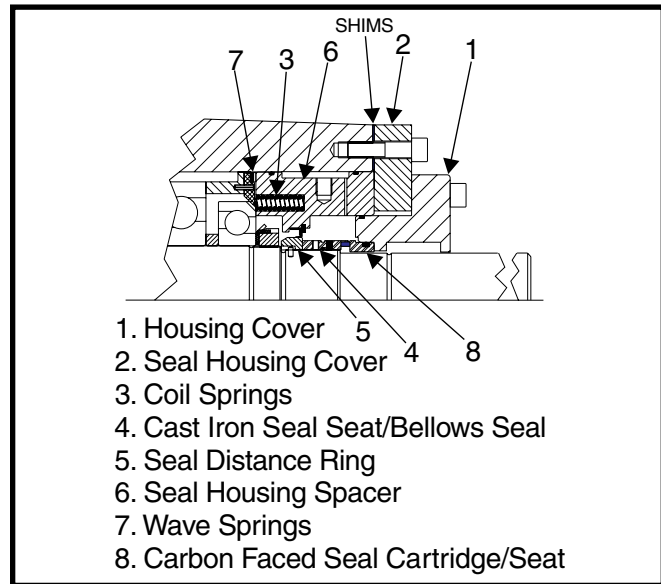

1. Housing Cover
2. Seal Housing Cover
3. Coil Springs
4. Cast Iron Seal Seat/Bellows Seal
5. Seal Distance Ring
6. Seal Housing Spacer
7. Wave Springs
8. Carbon Faced Seal Cartridge/Seat

Figure 1. 355 only

**CAUTION**

**WEAR PROPER SAFETY EQUIPMENT AND TAKE NECESSARY SAFETY PRECAUTIONS REQUIRED FOR THESE PROCEDURES.**

1. Evacuate compressor and oil separator (refer to S70-200/210 IOM or S70-300/301 IOM).
2. Remove drive coupling.

**NOTE:** Make provisions to catch several quarts of residual oil that will drain when seal housing cover is removed.

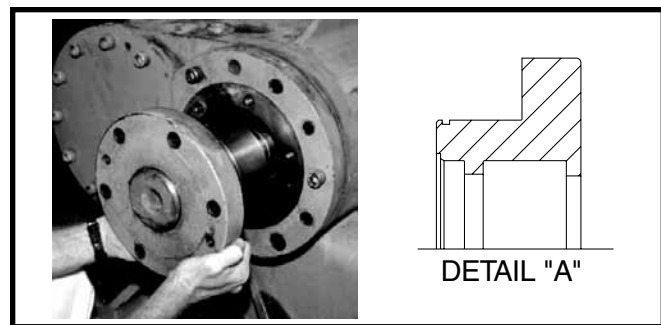

DETAIL "A"

Figure 2.

3. See Figure 2. Loosen socket-head capscrews and remove housing cover (1). If the housing cover looks like the one shown in Figure 2 Detail "A", this unit is the later style which has a lip seal in addition to the shaft seal. Go to step 4. If it is different, you have an original style unit. Continue to step 4 and ignore references to lip seal and retaining ring. The standard Shaft Seal Kit will repair all 355 shaft seals.

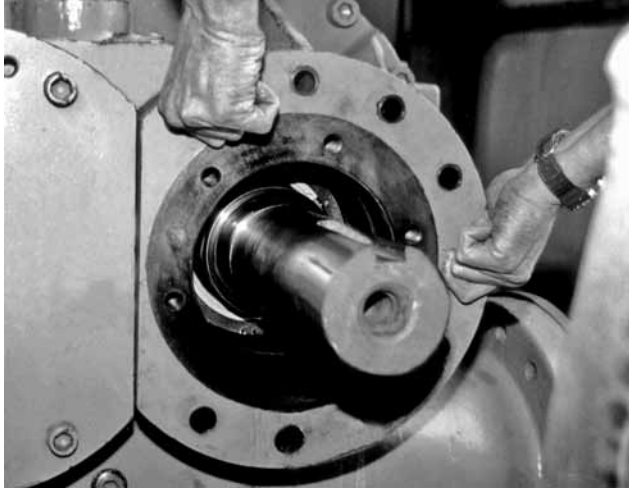

**Figure 3.**

- See Figure 3. Loosen capscrews evenly on seal housing cover (2) until spring pressure is released. Remove capscrews, seal housing cover (2) and shims. Remove seal housing spacer (6), using a seal removal tool. Remove coil springs from seal housing spacer. Remove cast iron seal seat/bellows seal (4) and discard\*. Remove seal distance ring (5) and retain. Wave springs (7) can be removed if desired.



**Figure 5.**

- See Figure 5. Remove retaining ring from seal housing spacer (6). Remove lip seal from seal housing spacer. Lip seal is a press fit and will need to be tapped or pressed out. Discard lip seal and retaining ring. This design is on compressors using housing cover shown in Fig. 4.

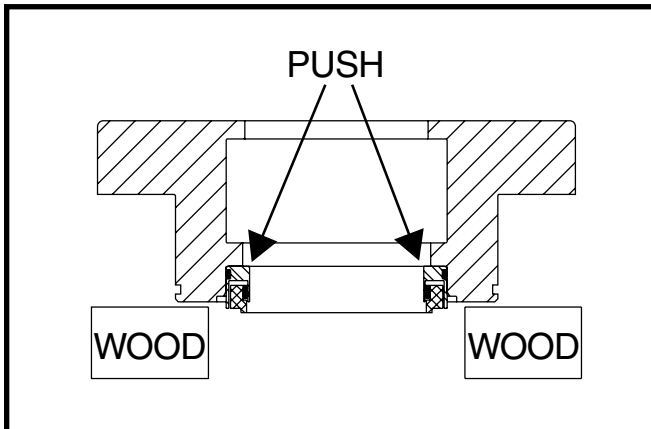

**Figure 4.**

- See Figure 4. Place housing cover (1) on two blocks of wood with mounting flange facing up. Push out the carbon-faced seal cartridge/seal seat using wood or plastic, and discard\*.

**NOTE:** Figure 4 shows the later housing cover used with lip seal. Earlier units will have a housing cover with a longer body extending past the carbon faced seal cartridge/seal seat. Wood blocks will not be needed for this type.

\* If the seal is being replaced under warranty, protect the seal and return with RMA forms.

### MODEL 355 SHAFT SEAL INSTALLATION

1. Thoroughly clean all parts to be reused and casing area. Remove scratches or marks with fine emery cloth. Wipe with soft clean cloth. Coat all parts with clean refrigerant oil.

**NOTE: Ensure orifice (oil feed hole in seal housing spacer) is clear of obstructions.**

2. Clean shaft; polish minor scratches with fine emery cloth. Ensure keyway edges are free of burrs. Wipe clean and coat shaft with clean refrigerant oil.

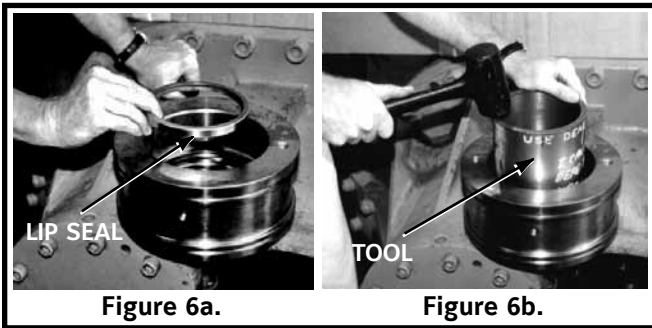

Figure 6.

**NOTE: Do not use grease on seal parts.**

**NOTE: If your seal housing spacer is not of the lip seal and retaining ring design, ignore references to them except for the O-rings on o.d. of seal housing spacer in Step 3.**

3. Place seal housing spacer (6) on a solid surface with spring pockets facing down. Place new lip seal in seal housing spacer with lip facing down. See Figure 6a. Press or tap lip seal using tool supplied in kit as shown. See Figure 6b. Install new retaining ring in groove above lip seal. Install new o-rings lubricated with clean refrigerant oil on seal housing spacer.



Figure 7.

4. Replace wave springs (7) in casing. Install coil springs (3) in spring pockets. Slide tool into bore of seal housing spacer (6) before sliding spacer over shaft. Note that the tool protects the lip seal during installation of the seal housing spacer (6). With tool inserted, slide seal housing spacer over shaft and into place with lifting hole at 12 o'clock position. See Figure 7.



**AVOID DAMAGE TO STATIONARY CARBON FACE SEAL SEAT AND ROTATING BELLOWS SEAL. DO NOT TOUCH SEALING SURFACES. ENSURE CARBON FACE IS NOT CHIPPED OR CRACKED.**

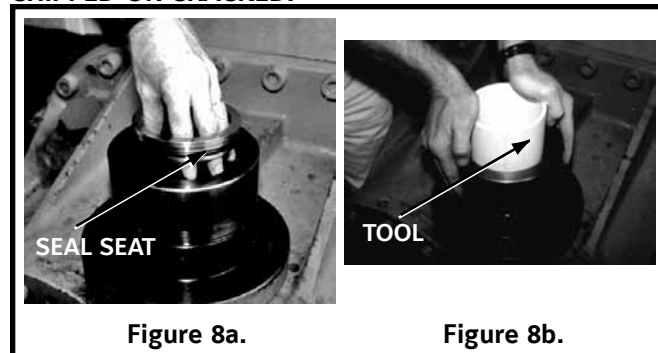

Figure 8.

5. Place housing cover (1) on flat surface with flange down. Oil seal seat (8) including O-ring with clean refrigerant oil. Place inside of housing cover with sealing surface (smooth finish) up. See Figure 8a. Cover seal surface with styrofoam pad included in kit. Press seal seat into place using tool provided with kit, being careful not to damage sealing surface. See Figure 8b. Remove tool and styrofoam pad. Install new O-ring on housing cover (1) and lube with clean refrigerant oil. Set aside.



**Figure 9.**

- Prior to installation of seal distance ring and rotating (bellows) portion of seal (4), ensure seal distance ring pin does not contact bottom of slot in seal. See Figure 9. Ensure that sleeve on i.d. of rotating seal (beneath set screws) is fully seated to protect shaft.



**ALL MATING FACES OF SEAL SEAT AND BELLWS SEAL MUST BE COATED WITH CLEAN REFRIGERANT OIL AT INSTALLATION. DRY START-UP COULD CAUSE SEAL DAMAGE.**

- Install seal distance ring (5). See Figure 10a. Be sure notch in ring engages pin on shaft. Oil bellows seal (4) including o-ring and carefully slide over shaft against seal distance ring (5). See Figure 10b. Ensure pin on seal distance ring engages notch in bellows seal. Using flashlight and inspection mirror ensure bellows seal is flush with distance ring (notch engages pin). If gap is noted, reseal seal. Next, hold bellows seal against seal distance ring and tighten four set screws in a crisscross pattern using allen wrench or ratchet and bit included in kit. See Figure 10c. Reinstall shims, seal housing cover (2) and capscrews. Ensure pin in seal housing cover engages hole in seal housing spacer. Torque capscrews in a crisscross pattern to 144 ft lb (195 Nm). Using care not to damage seal seat and bellows seal, slide housing cover (1) over shaft with word "TOP" at 12 o'clock position. Install and torque bolts to 144 ft lb (195 Nm) using a crisscross pattern.

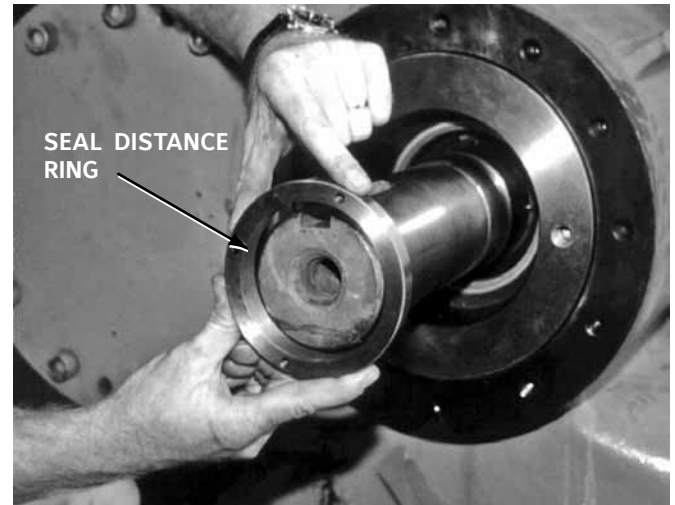

**Figure 10a.**



**Figure 10b.**



**Figure 10c.**

SHAFT SEAL COMPONENTS					
	163	193	233	283	355
Shaft Seal Kit	534M0163G01	534M0163G02	534M0163G03	534M0163G04	534M0163G05
Dowel Pin, 5H8 x 10	534A0037H12	534A0037H12	534A0037H12	534A0037H12	534A0037H12
Roll Pin, 1/8 x 1/2	534A0038H05	-	-	-	-
Roll Pin, 3/16 x 1/2	-	534A0038H01	-	-	-
Roll Pin, 1/4 x 5/8	-	-	534A0038H08	534A0038H08	534A0038H08
Roll Pin, 5/16 x 1	-	-	-	-	534A0038H10
Shaft Seal	534C0701H01	534C0701H02	534C0701H03	534C0701H04	534C1147H06
O-ring (1 each)	-	-	-	-	980A0012B90
O-ring (2 each)	980A0012B76	980A0012B84	980A0012B90	980A0012B96	980A0012H04
Installation Tool	-	-	-	534A0335H01	-
Lip Seal Tool	-	-	-	-	534B0499H01
Seal Installation Tool	-	-	-	-	534C1148H01
Retaining Ring	-	-	-	-	333Q0000376
Lip Seal	-	-	-	-	534B0426H01
Ratchet and Bit	-	-	-	-	534M0613G01

**NOTES**

NOTES