



BY JOHNSON CONTROLS

Form 070.020-TB (APR 2011)

**TECHNICAL BULLETIN**

File: EQUIPMENT MANUAL - Section 70  
Replaces: 070-020 TB (AUG 2008)  
Dist: 1, 1a, 1b, 1c, 4a, 4b, 4c

# PhD Vibration Monitoring System With Quantum™ & Quantum™ LX

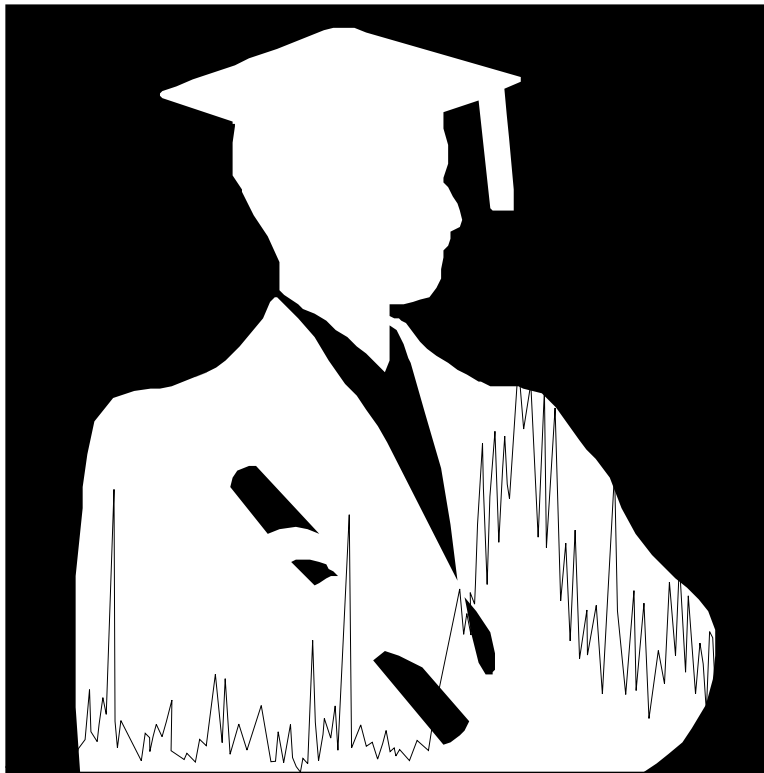

Please check [www.johnsoncontrols.com/frick](http://www.johnsoncontrols.com/frick) for the latest version of this publication.

## Table of Contents

Figure 1 - Common Vibration Spectra for Screw Compressor .....	3
Figure 2 - How Phd Monitoring Works .....	3
Motor Bearing RTD Temperature Sensing.....	4
PhD Acceleration Monitoring .....	4
Functional Description of Quantum™ or Quantum™ LX PhD Vibration Monitoring System .....	4
Figure 3 - Sample Quantum™ screen for setting alarms and shutdown. ....	5
Figure 4 - Sample Quantum™ LX screen for RTD settings. ....	6
Figure 5 - Sample Quantum™ LX screens for vibration settings.....	6
Figure 6 - Quantum™ LX RTD Calibration.....	7
Figure 7 - Sample Quantum™ LX screen for vibration and RTD display. ....	7
Sensitivity and Range Selection.....	8
Accelerometer .....	8
Motor Bearing RTD Temperature Sensors .....	8
Figure 8 - Accelerometer.....	8
Figure 9 - Motor Bearing RTD Temperature Sensor .....	8
Motor Stator RTD Temperature Sensors.....	8
BASIC PhD VIBRATION MONITORING SYSTEM .....	9
OPTION #1 SCREW COMPRESSOR ONLY .....	10
OPTION #2 MOTOR BEARING RTD TEMPERATURE SENSORS .....	11
OPTION #3 MOTOR WITH ANTIFRICTION BEARINGS .....	12
OPTION #4 MOTOR STATOR RTD TEMPERATURE SENSORS .....	13
Figure 10 - PhD Wiring Connections .....	14

### Vibration Monitoring Saves Compressors

No one likes to talk about compressor failures, however, like all rotating machinery, compressors will eventually fail if they run long enough. One advantage of using rolling element bearings, as opposed to sleeve bearings in rotary screw compressors, is that the early stages of failure are relatively easy to detect. With a regular and disciplined periodic vibration analysis program, most bearing failures can be detected in the very early stages.

When bearing fatigue is detected in time, the compressor rebuild will be much less expensive. This is because only the bearings need to be replaced and not the expensive rotors and housings. Failure detection in the early stages also allows the repair to be scheduled to avoid disruption to the plant's operation. Normally, compressors can continue to run for months after the first signs of bearing failure are detected, (as long as vibration monitoring is utilized to track the progression of the damage) without risking catastrophic failure.

### Effective Monitoring Is Not Easy

One of the disadvantages of periodic vibration monitoring is that the technician must often be familiar with many different types of machinery, and is expected to predict failures without giving false alarms.

One of the characteristics of a screw compressor is that the dominant vibration signal will always be at lobe passing frequency or one of its harmonics. The vibration signals generated by the early stages of bearing fatigue are a much lower amplitude and at higher frequency than lobe passing and its harmonics.

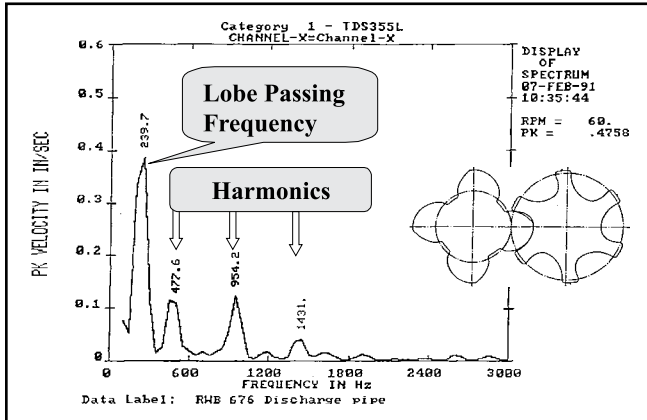

Figure 1 - Common Vibration Spectra for Screw Compressor

Without specific training on rolling bearing equipped rotary screw compressors, the technician may often give recommendations that are either too conservative or that might miss an important warning condition. Also, since the measurement is periodic, it will not catch a temporary or transient problem that could still be a threat to the compressor.

Onboard vibration monitoring systems overcome some of these problems because they are monitoring the compressor all the time. However, many of the systems for sale today, often at very high price levels, were designed primarily to monitor sleeve bearing equipped turbo-machinery, or low speed reciprocating machinery. Many of these systems monitor only overall velocity or displacement to track bearing deterioration, or they utilize proximity probes to determine when rotors have moved from their original positions, indicating loss of bearing integrity. In

some cases the normal lobe passing frequencies in a healthy screw compressor give signal levels well above the alarm levels that could be expected due to bearing deterioration. This means that the systems can easily give false alarms on normal conditions, or miss the early signs of bearing failure because the increase is not significantly above the healthy vibration level.

### What is the PhD Monitoring System?

The Frick PhD Vibration Monitoring system is a continuous onboard vibration monitoring system that utilizes the best current technology to detect the early stages of compressor bearing failure. It monitors the compressor continuously and alarms the operator when a condition develops that would indicate the early stages of bearing failure. The bearings are monitored by onboard accelerometers mounted over the bearing positions on both ends of the compressor. The signals from these sensors are then modified and filtered in such a way that the normal vibration levels from compressor lobe passing and its harmonics will not give false alarms. See Figure 2.

The normal accelerometer mounting for compressor monitoring with the PhD system utilizes two accelerometers. All Frick compressors are predrilled and tapped with 1/4 inch-28 mounting holes to allow solid attachment of the PhD accelerometers in locations near to the bearings on each end of the compressor. The locations are chosen to give a good signal level for both the radial and axial thrust bearings without requiring separate axial probes. The combination of two radial locations have been proven to pick up early stages of bearing fatigue regardless of which bearing position experiences the earliest damage.

The system is tuned to look in the frequency ranges that give the best indication of the early signs of bearing fatigue and to ignore frequencies that might give misleading signal levels. This is a major advantage of the PhD system over most of the other vibration monitoring systems on the market. It is designed to protect your compressors, based on Johnson Controls' knowledge and testing of the best way to detect failures in roller bearing equipped screw compressors.

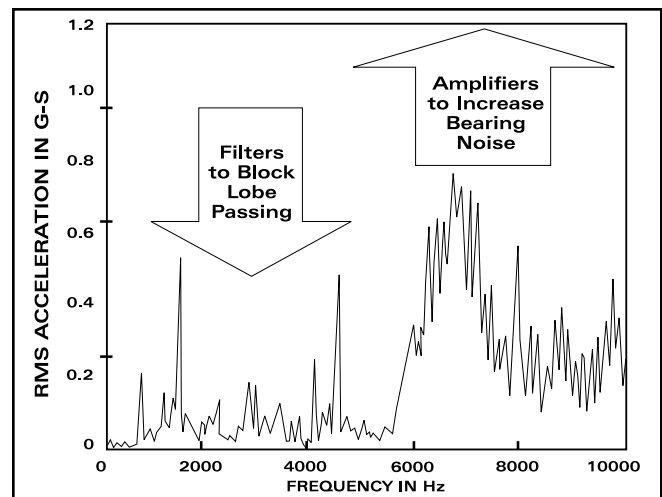

Figure 2 - How PhD Monitoring Works

Laboratory testing found that the system would also detect temporary liquid slugging and allow for automatic rapid shut-down when severe slugging was detected. This is one of the advantages of onboard monitoring over periodic monitoring. Unless your vibration technician has his meter on the compres-

sor when a liquid slug occurs he cannot save the compressor. The PhD system is continuously watching for a severe slug and can rapidly shut down the compressor when this condition is detected.

The output signals from the accelerometers are directly fed to the Quantum™, or Quantum™ LX, panel Analog board. It is no longer necessary to purchase additional electronics components to do the signal conditioning. The Quantum™ or Quantum™ LX is used to monitor the machine's vibration level and compare against programmed, adjustable alarm and shutdown setpoints. Adjustable time delays are also available for both the alarm and shutdowns, to avoid nuisance alarms or cutouts from transient conditions that may not be serious. Alarm and Shutdown levels on the compressor are set in units of g's Frick® or (gF), (PhD modified acceleration units - gF).

The PhD system is also very effective for monitoring vibration of an anti-friction bearing equipped motor. Since the PhD system is tuned to look for fatigue of rolling element bearings, the failure signature of rolling element bearings in the motor can also be monitored and specific alarm and setpoint levels set to detect increasing vibration in the motor bearings. When properly set, the initiation of the motor alarm will often be the first indication that the motor bearings need to be lubricated.

PhD is not the most effective system to monitor sleeve bearing equipped motors, and it is not recommended for this application.

### Motor Bearing RTD Temperature Sensing

While the PhD system is effective at measuring motor vibration, it also offers the use of motor RTD's for monitoring of motor bearing condition. Motor vibration levels or Motor Bearing Temperatures can be utilized to monitor motor condition.

Motor manufacturers have expressed confidence in the use of motor bearing temperature sensing as an effective method to detect developing problems in rolling element motor bearings. Bearing temperature is more meaningful on motors than compressors because the bearings are grease lubricated on motors, and a developing problem will generate a measurable increase in the bearing temperature. This level can be used to alarm for re-grease of bearings, or shutdown for bearing replacement in the event that bearing damage is detected.

When properly applied, and maintained, the PhD system can greatly reduce the risk of catastrophic compressor and motor failure due to a variety of causes. It will also give an overall improvement in operating reliability as well as reducing the risk of a catastrophic and expensive failure.

In a majority of applications the most cost effective PhD monitoring solution would utilize two compressor accelerometers and two motor bearing RTD's in combination (Basic PhD System, page 9).

The RTD output wires directly to Analog Board 1 in the Quantum™ or Quantum™ LX and monitors temperature changes in the bearings.

### PhD Acceleration Monitoring

The PhD Acceleration system is integrally built into the Quantum™ or Quantum™ LX Analog board, and used for monitoring of the compressor bearings. The system is designed to

distinguish repetitive impacts from the wide-band-machine vibration signals.

These repetitive impacts are generated by:

- Over rolling bearing defects.
- Gear box problems, etc.,
- Rubbing, or sliding of metal surfaces.

The acceleration signal is measured in raw frequency from the accelerometers. Software on the analog board processes the signal with on-board filtering, optimized for screw compressor applications.

### Functional Description of Quantum™ or Quantum™ LX PhD Vibration Monitoring System

The Frick® Quantum™ or Quantum™ LX control panel provides the integration of the PhD Vibration Monitoring System into the compressor control system.

**Vibration Monitoring System.** The PhD channel on the analog board is connected to an accelerometer through the appropriate Frick® supplied cable assembly. The accelerometer provides the input signal from the machine location being monitored. Two accelerometers connected to two analog channels are normally used, one on each compressor bearing housing. The analog board processes the input signal from the sensor and after signal conditioning provides this input directly to the Quantum™ or Quantum™ LX motherboard panel. The PhD accelerometer outputs are connected to the Quantum™ or Quantum™ LX analog board channels 17, and 18 (PhD Channel #1 and #2), 19, and 20 (PhD Channel #3 and #4). Four channels allow the monitoring of two compressor locations and two motor locations.

When the system is ordered with the compressor package, the channels are configured at the factory. Field adjustment for the alarm and shutdown levels, and time delays must be made after running the unit and determining the initial normal levels. Field adjustment is possible to more closely tune the alarms and shutdowns for a particular application and compressor size.

The following example illustrates a typical setup for monitoring the suction end of the compressor.

1. The accelerometers are mounted at the factory with 1/4-28 studs into the compressor housings.
2. The cable from the accelerometers is factory wired direct to the proper analog channel within the control panel.
3. The software has already been preconfigured at the factory. (However, in the Quantum™ it only needs to be enabled through factory setup. See Quantum™ manual S90-010 FSI, or Factory Setup Instructions. There is no Factory Setup in the Quantum™ LX and the settings can be modified in User Level #2.) The PhD hardware is attached to the analog board channel 17 (PhD Channel #1) for monitoring the suction end of the compressor.

Once unit is started, run the compressor at expected design pressures while manually changing slide valve position from maximum to minimum, monitoring the gF level on all channels. Repeat this procedure several times to be sure the measured levels are representative. Record the highest levels detected on each channel and make a record of this reading where it will not be lost.

Set the alarm level for each channel to 2X highest level seen during initial run for each channel. Normally a 99 second time delay is used on the alarm setpoint to avoid nuisance alarms. Next set the shutdown level as 3X highest level seen during initial running for each channel. Normally a short time delay is used on the shutdown setting, (1 to 3 seconds). The short time delay is designed to detect liquid slugging or other catastrophic occurrences. With some operational history, the alarm and shutdown levels can be adjusted slightly higher or lower to either give earlier warning of changes, or avoid transient nuisance alarms.

Example of setup:

- Run unit and read highest reading on outlet end bearings at any slide valve position, (for example, say the reading was 2.0 gF).
- Set the High Alarm at 4.0 gF with a 99 second time delay.
- Set the High Shutdown at 6 gF with a one second time delay.
- If the Shut down trips during starting transients set the time delay slightly longer, (2-5 seconds).

The actual number set in gF does not mean much, and general setting guidelines are difficult to predict ahead of initial running.

For example, high power applications, and compressors with internal gearboxes will generally display higher initial readings than low power applications without gearboxes. The main purpose with PhD is to monitor increasing levels of acceleration in the frequencies that indicate the onset of bearing fatigue.

The units are designed with the proper filters to separate the defect signal from the wide band acceleration and convert to signals proportional to the defect.

The derived signal, representing the PhD acceleration signal, is compared with the alarm level preset.

The measurement is done in gF (1 gF is approximately equal to 9.8 m/s<sup>2</sup>, but the derived signal is not exactly convertible to standard acceleration units). A gF is a derived unit for surface acceleration measurement.

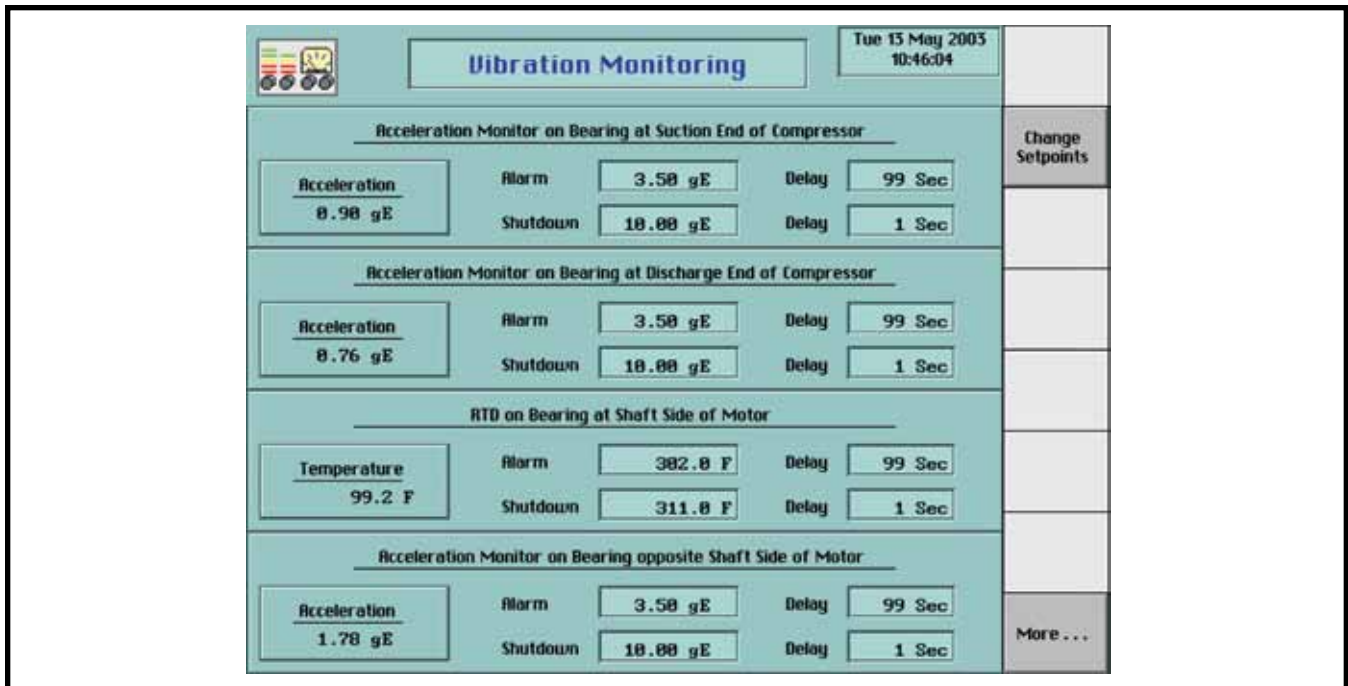

Figure 3 - Sample Quantum™ screen for setting alarms and shutdown.

22:32:36  
Jun 19 2005

### Auxiliary Analog Input Safeties

Page 1

		Low		High	
		Setpoint	Delay	Setpoint	Delay
Motor RTD Shaft End <input type="button" value="When Running"/>	Warning	0.0 °F	99 SEC	186.0 °F	99 SEC
	Shutdown	0.0 °F	1 SEC	203.0 °F	1 SEC
Motor RTD Opp. Shaft End <input type="button" value="When Running"/>	Warning	0.0 °F	99 SEC	186.0 °F	99 SEC
	Shutdown	0.0 °F	1 SEC	203.0 °F	1 SEC
Auxiliary Analog 3 <input type="button" value="Disabled"/>	Warning	29.7 Hg	0 SEC	29.7 Hg	0 SEC
	Shutdown	29.7 Hg	0 SEC	29.7 Hg	0 SEC
Auxiliary Analog 4 <input type="button" value="Disabled"/>	Warning	29.7 Hg	0 SEC	29.7 Hg	0 SEC
	Shutdown	29.7 Hg	0 SEC	29.7 Hg	0 SEC
Auxiliary Analog 5 <input type="button" value="Disabled"/>	Warning	29.7 Hg	0 SEC	29.7 Hg	0 SEC
	Shutdown	29.7 Hg	0 SEC	29.7 Hg	0 SEC

Figure 4 - Sample Quantum™ LX screen for RTD settings.

20:49:19  
Jun 03 2005

### Vibration

#### Compressor

Suction End	High Warning	High Shutdown	High Shutdown Delay	Current	Offset	Device Source	Device Channel
3.5 gF	99 SEC	10.0 gF	1 SEC	1.0 gF	0.0 gF	Analog Board1(ASCII)	17
Discharge End	High Warning	High Shutdown	High Shutdown Delay	Current	Offset	Device Source	Device Channel
3.5 gF	99 SEC	10.0 gF	1 SEC	1.1 gF	0.0 gF	Analog Board1(ASCII)	18

#### Motor

Shaft Side	High Warning	High Shutdown	High Shutdown Delay	Current	Offset	Device Source	Device Channel
0.0 gF	99 SEC	10.0 gF	1 SEC	0.0 gF	0.0 gF	None	19
Opposite Shaft	High Warning	High Shutdown	High Shutdown Delay	Current	Offset	Device Source	Device Channel
0.0 gF	99 SEC	10.0 gF	1 SEC	0.0 gF	0.0 gF	None	20

Figure 5 - Sample Quantum™ LX screens for vibration settings.

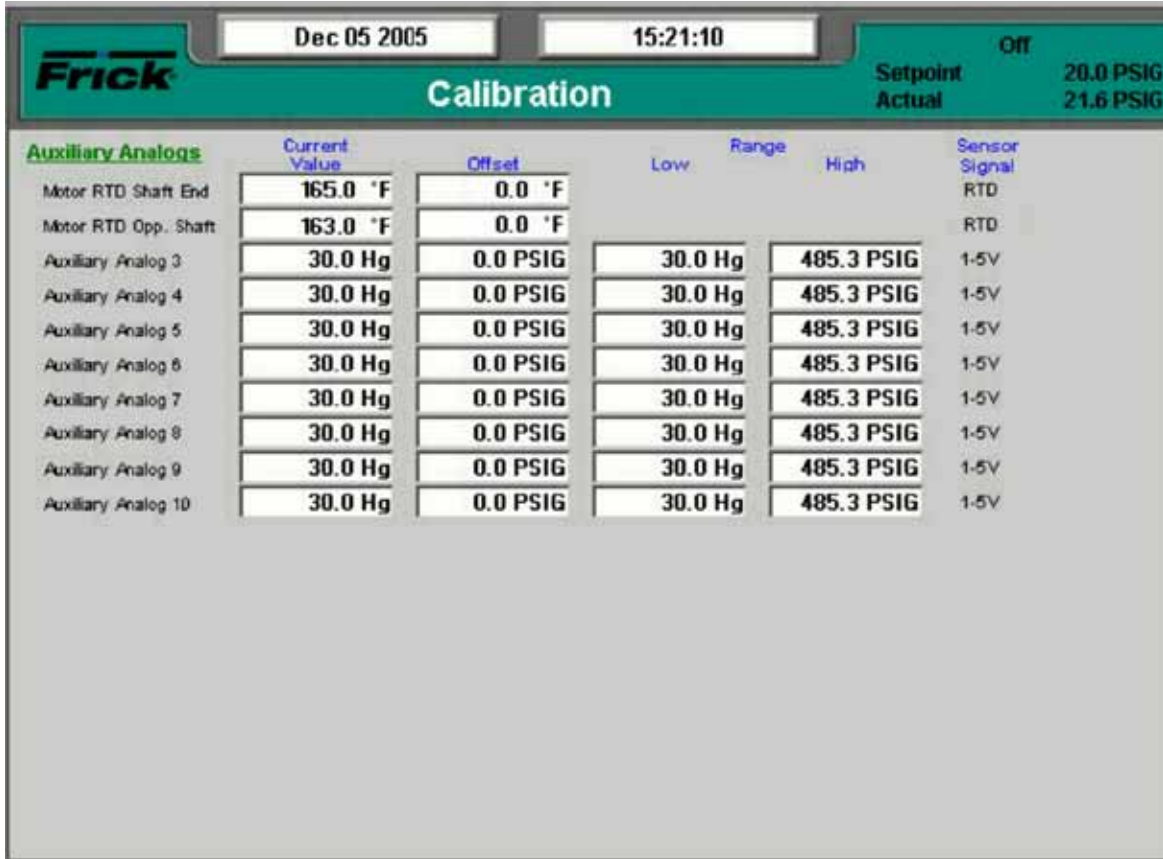

Figure 6 - Quantum™ LX RTD Calibration.

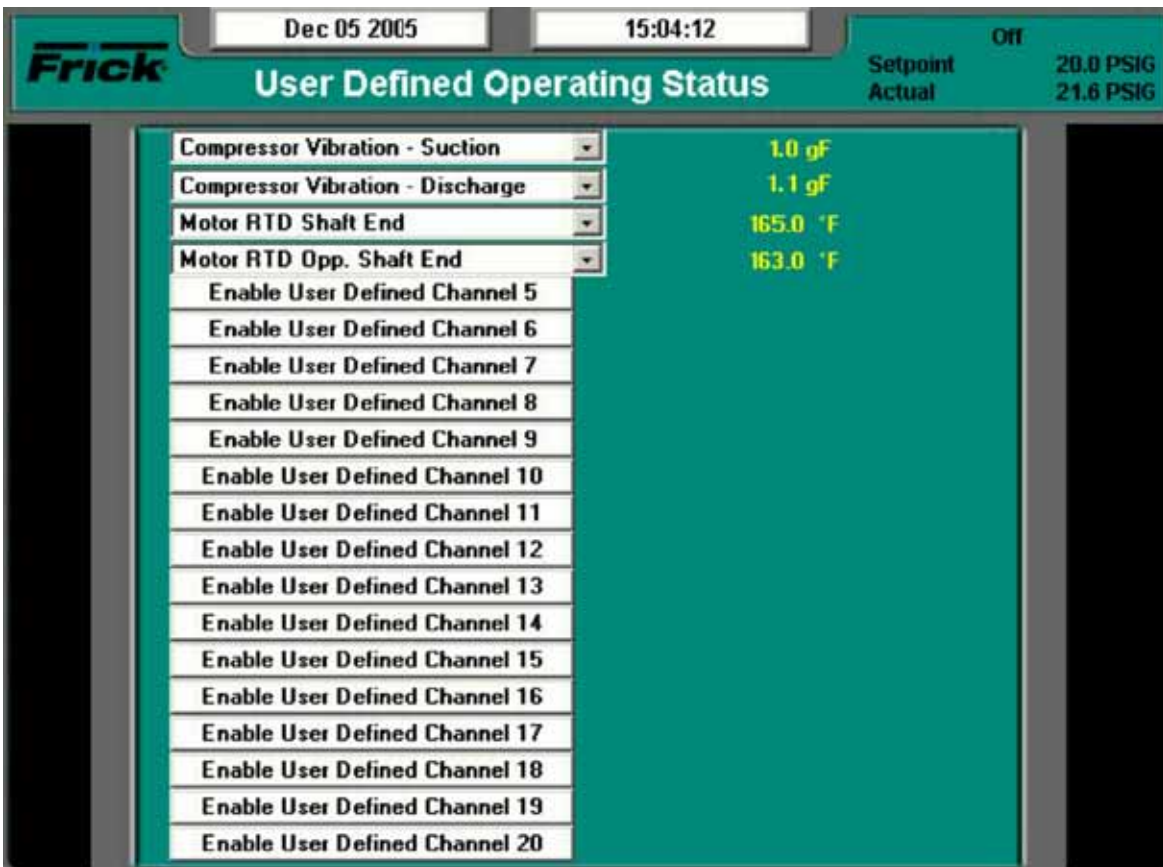

Figure 7 - Sample Quantum™ LX screen for vibration and RTD display.

## Sensitivity and Range Selection

No field settings or adjustments are necessary.



Figure 8 - Accelerometer

### Accelerometer

#### Accelerometer

- For use with PhD Acceleration System
- Economical, rugged, general purpose
- Sensitivity, 100 mV/g for greater range and to optimize application use
- Designed to meet stringent CE, EMC, UL, CSA, and FM requirements
- Cable shield and braid connected to sensor housing for better noise rejection (Signal wire is white, Return wire is black)
- Corrosion Resistant
- Miswiring Protection
- 1/4-28 mounting stud provided for positive attachment to compressor housings.
- Accelerometer mounting pad and Adhesive Bypac provided for mounting accelerometer to motor bearing areas or other areas not predrilled at the factory.

## Motor Bearing RTD Temperature Sensors

- The unit mounted Quantum™ and Quantum™ LX is PhD ready but motors must be ordered with optional sensors.
- Bearing RTD should be 100 ohm Platinum 2 or 3 wire (3 wire, 0.00385 TCR preferred), spring loaded pressure tube type. Supplied by motor manufacturer.
- The RTD output will monitor temperature changes in bearings from 0° to 180°C

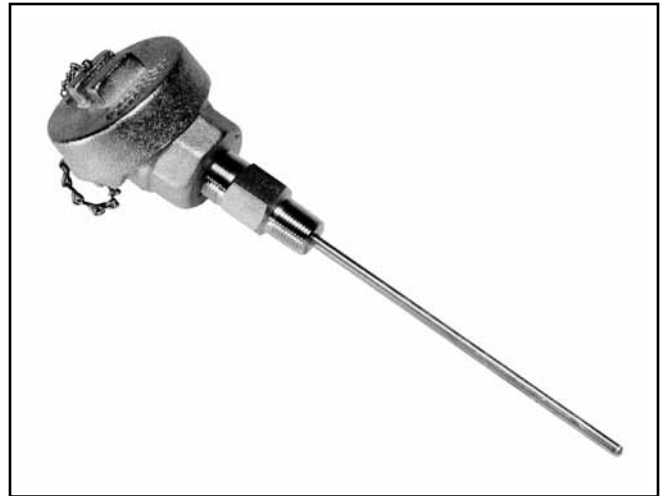
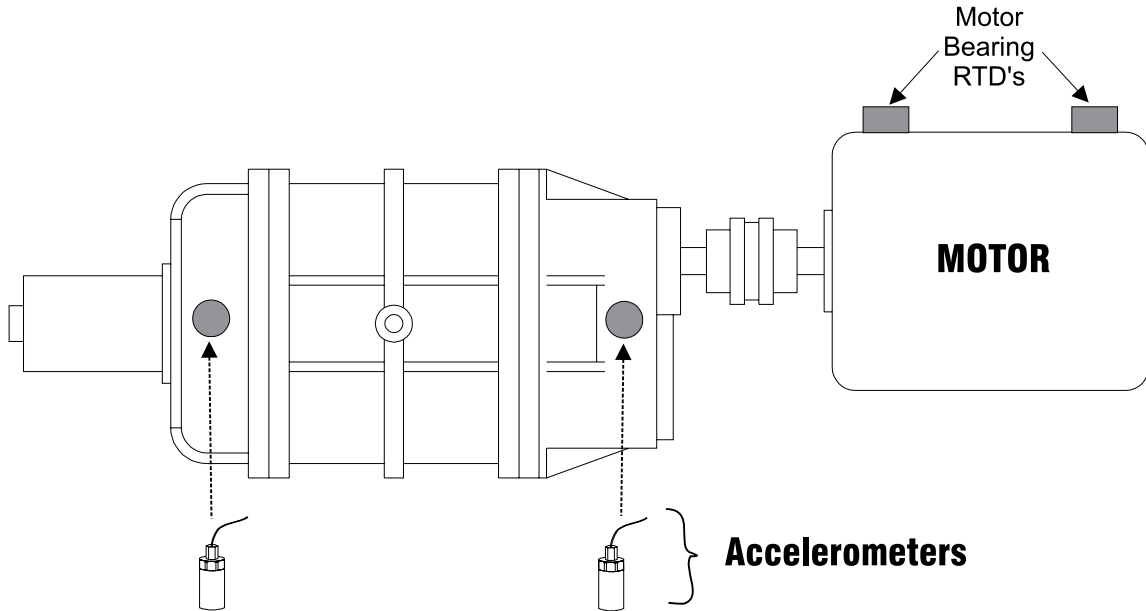

Figure 9 - Motor Bearing RTD Temperature Sensor

## Motor Stator RTD Temperature Sensors

- The unit mounted Quantum™ and Quantum™ LX is PhD ready but motors must be ordered with optional sensors.
- Stator RTD should be 100 ohm Platinum 2 or 3 wire (3 wire, 0.00385 TCR preferred), mounted in the motor stator. Supplied by motor manufacturer.
- The RTD output will monitor temperature changes in windings from 0° to 180°C.

**INSTALLATION INFORMATION FOR VIBRATION MONITORING EQUIPMENT  
BASIC PhD VIBRATION MONITORING SYSTEM  
SCREW COMPRESSOR ACCELEROMETERS & MOTOR BEARING RTD TEMPERATURE SENSORS**



**Option #1: Two Accelerometers - installed on the compressor. Each accelerometer connects to Analog Board 1 installed in a Quantum™, or Quantum™ LX, Panel.**

**Option #2: includes the wiring of two 100 ohm platinum 2 or 3 wire RTD assemblies. The bearing RTD's are the spring loaded pressure tube type. The RTD output will wire directly to Analog Board 1 in the Quantum™, or Quantum™ LX panel and monitor temperature changes in the bearings. Price does NOT include motor bearing RTD's. Order motor with bearing RTD option.**



**Quantum™ Panel**



**Quantum™ LX Panel**

**NOTE: Above graphics are not to scale.**

**INSTALLATION INFORMATION FOR VIBRATION MONITORING EQUIPMENT  
OPTION #1  
SCREW COMPRESSOR ONLY**

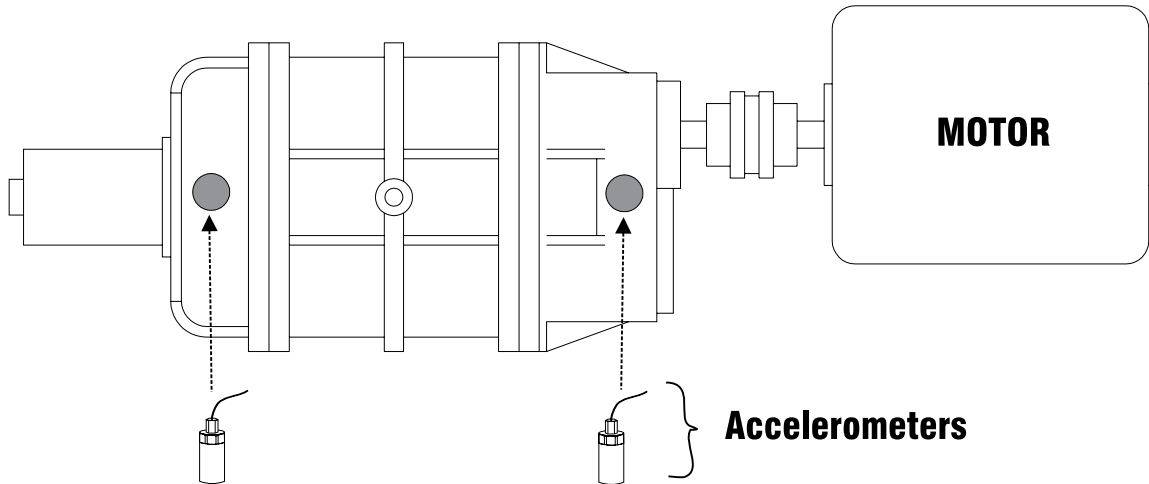

**Two Accelerometers - installed on the compressor. Each accelerometer connects to Analog Board 1 installed in a Quantum™, or Quantum™ LX panel.**



**Quantum™ Panel**



**Quantum™ LX Panel**

**NOTE: Above graphics are not to scale.**

**INSTALLATION INFORMATION FOR BEARING MONITORING EQUIPMENT  
OPTION #2  
MOTOR BEARING RTD TEMPERATURE SENSORS**

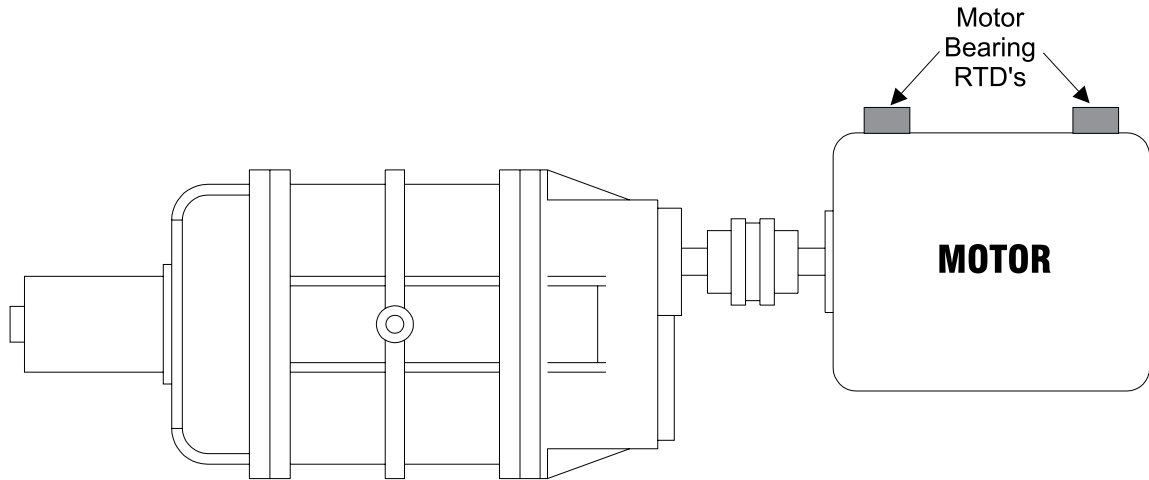

Option #2 includes the wiring of two 100 ohm platinum 2 or 3 wire RTD assemblies. The bearing RTD's are the spring loaded pressure tube type. The RTD output will wire directly to Analog Board 1 in the Quantum™, or Quantum™ LX panel and monitor temperature changes in the bearings. Price does NOT include motor bearing RTD's. Order motor with bearing RTD option.



Quantum™ Panel



Quantum™ LX Panel

NOTE: Above graphics are not to scale.

**INSTALLATION INFORMATION FOR VIBRATION MONITORING EQUIPMENT  
OPTION #3  
MOTOR WITH ANTIFRICTION BEARINGS**

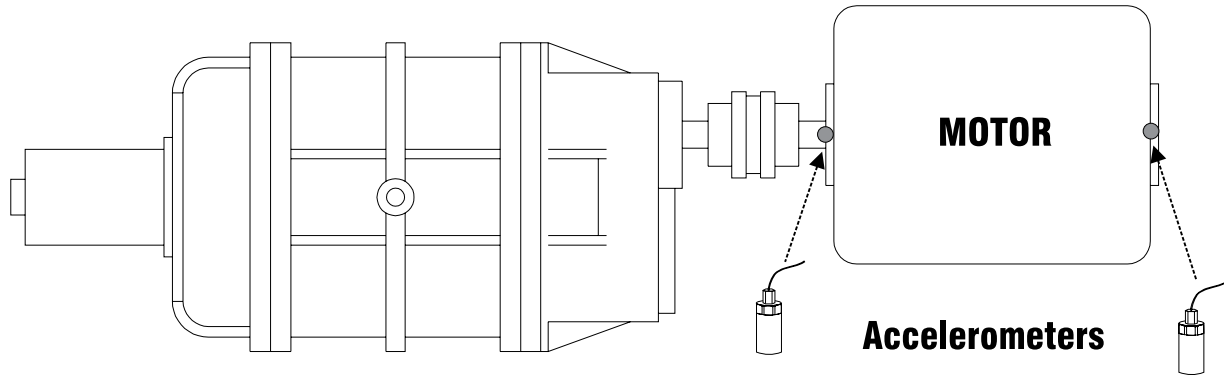

**Two Accelerometers - installed on the motor. Each accelerometer connects to an Analog Board 1 installed in a Quantum™, or Quantum™ LX panel.**



**Quantum™ Panel**



**Quantum™ LX Panel**

**NOTE: Above graphics are not to scale.**

**INSTALLATION INFORMATION FOR BEARING MONITORING EQUIPMENT  
OPTION #4  
MOTOR STATOR RTD TEMPERATURE SENSORS**

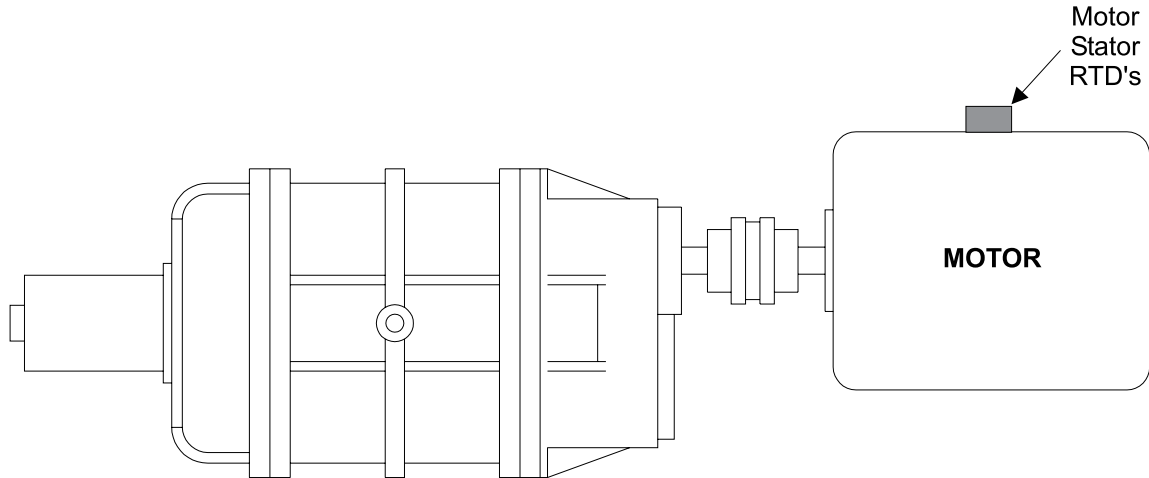

Option #4 includes the wiring of three 100 ohm platinum 2 or 3 wire RTD assemblies. The RTD output will wire directly to Analog Board 1 in the Quantum™, or Quantum™ LX panel and monitor temperature changes in the motor windings. Price does NOT include motor stator RTD's. Order motor with stator RTD option.

**NOTE:** Thermal overload protection of the motor is required by the latest revision of National Electric Code (NEC) for all applications with Variable Frequency Drives.



Quantum™ Panel



Quantum™ LX Panel

NOTE: Above graphics are not to scale.

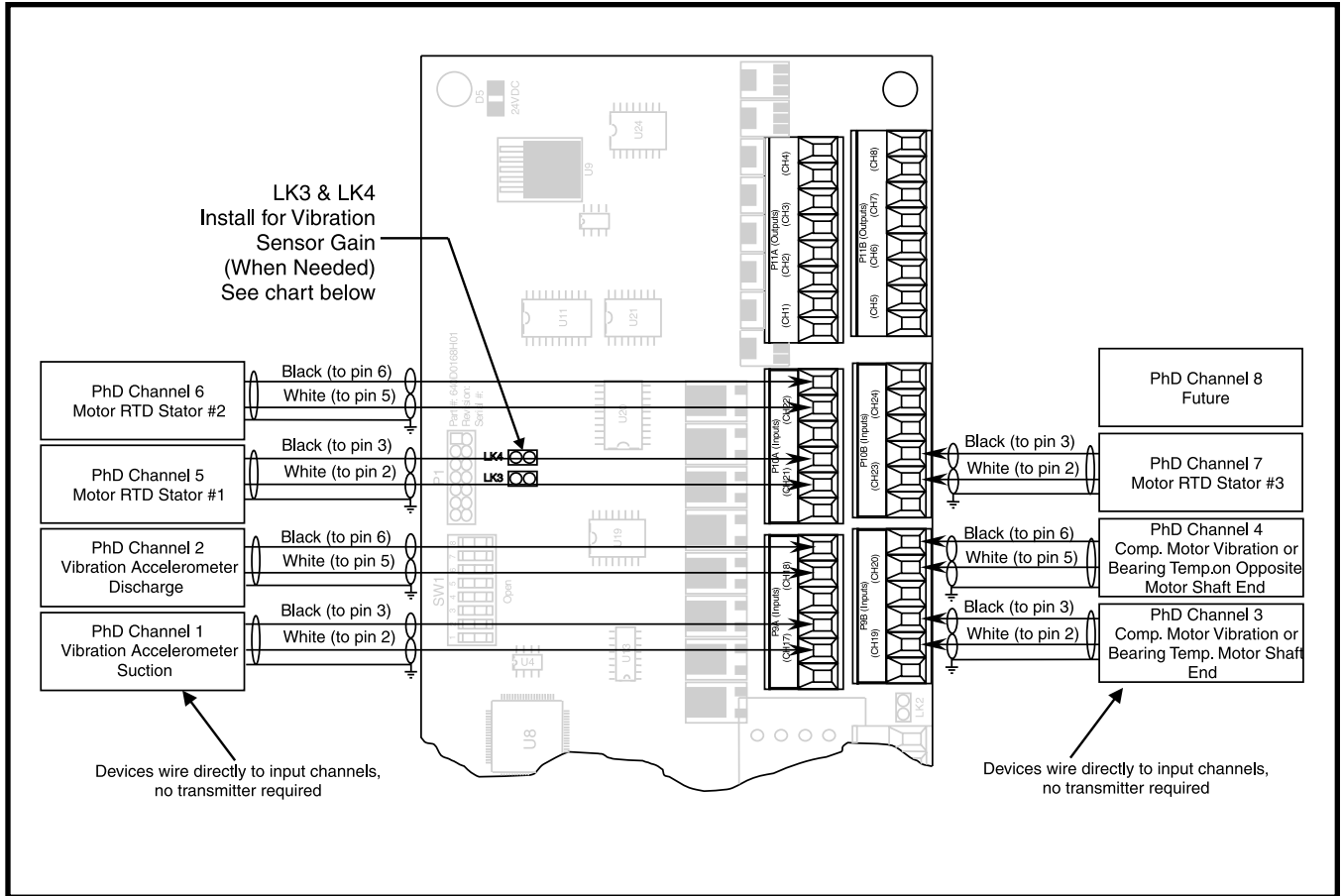

Figure 10 - PhD Wiring Connections

Gain	LK3	LK4
1:1	Out	Out
11:1 *	Out	In
21:1	In	Out
31:1	In	In

\* Standard Setting

**NOTES**

