

REFRIGERATION EQUIPMENT

For Food and Beverage

A complete line of
Industrial Refrigeration products



Frick[®]
BY JOHNSON CONTROLS

Why buy FRICK products?

FRICK HAS A REPUTATION FOR
MAKING RELIABLE PRODUCTS



Frick began building quality products in Waynesboro, PA, USA in 1853. We built our first refrigeration compressor in 1883 and have been on the cutting edge of technology ever since. Each year, Frick continues to be stronger and strengthens its reputation for reliability, world-class engineering and application knowledge.

PART OF JOHNSON CONTROLS



As a part of Johnson Controls, Frick has access to the technical and financial resources of a Fortune 100 company. This allows us to share knowledge among our various sales and service organizations around the world.



FRICK FACTOR NETWORK

When you purchase a Frick industrial refrigeration system from your Frick Factor, you get the benefits of Frick product and service experience. Frick Factors have the skills to understand complex processes, product applications, and provide reliable, energy-wise installations, and service after the installation.

STATE-OF-THE-ART TECHNOLOGY IN BOTH DESIGN AND
MANUFACTURING

We lead the industrial refrigeration industry with cutting edge controls technologies that allow for seamless system integration. Our product innovations continue to be a major focus as we strive to bring tomorrow's products to the marketplace today.

ENGINEERING EXCELLENCE

Frick engineers have provided reliable products for over 150 years. Frick engineers continually refine existing products, adding features and incorporating the newest technologies. This constant evolution of products ensures that Frick and



Frick Factors will deliver customer satisfaction by providing the most technologically advanced equipment in the industry. As we make changes to improve the performance of current products, Frick engineers ensure that these improvements can be applied to previous installations. This allows continual upgrades to existing equipment and allows you to keep your Frick equipment current.

QUALITY, SATISFACTION AND RELIABILITY

The Industrial refrigeration industry places high demands on the equipment it uses. Today's equipment must be easy to maintain and meet high standards for quality, reliability and energy efficiency. Unit designs must be both robust and easily installed. Frick products accomplish all of these goals. High quality materials, innovative design and modern manufacturing methods add up to a product that is unmatched in overall quality. JOHNSON CONTROLS QUALITY POLICY - We will deliver products and services that conform to our customer's requirements and strive to exceed their expectations.

ENERGY EFFICIENT

Facility owners and operators are focused on energy efficiency now more than ever. Energy efficiency investments must provide a reasonable payback. Frick's many years of experience in the industrial refrigeration industry provides for varied and innovative energy efficiency solutions for your system. As an example, our VSD drives with unique liquid cooling ensure that your compressor operates at the most energy efficient level. Our cutting edge designs, along with Frick Control Systems and the use of VSD's can dramatically reduce operating costs.

ENGINEERED CONTROL SYSTEMS FEATURE
Q-NET TECHNOLOGY

Get optimum performance when you use Q-Net to take control of your refrigeration system. View, monitor and control your entire system by changing setpoints; react to system changes from one location because everything is



linked. Our constant evaluation of best practices regarding energy conservation and system performance keeps pace with current technologies and sets the standard by which competition is gauged. We offer nearly limitless expansion of your controls capability to keep pace with controls technology. Select from complete PLC based Engineered Control Systems to Q-Net Technology panels.



SUPERIOR SYSTEM INTEGRATION

Our expertise in each product area means a better understanding of how to build a complete and superior refrigeration system with integrated controls. This complete system integration allows for a dependable, efficient and sustainable refrigeration system.

COOLWARE

Coolware selection software enables the user to select the best system components for a refrigeration system.



Coolware allows products to be selected, priced, and placed directly into an order document, assuring that the correct equipment is ordered. It also provides flexibility in selection considerations to model a total system that is green, sustainable and efficient. Coolware is the most sophisticated and complete software found in industrial refrigeration today.

WE ARE ENVIRONMENTALLY GREEN

Ammonia (the primary refrigerant used for industrial refrigeration) and CO₂ are both natural refrigerants that are environmentally friendly and have low Ozone Depletion Potential (ODP) and low Global Warming Potential (GWP).

*NATURAL
REFRIGERANTS
DON'T LEAVE A
FOOTPRINT!*

AFTERMARKET SERVICE

If you have FRICK equipment, it is our policy to support it. Our technical support does not end with the warranty. The Baltimore Parts Center online ordering system is designed to help Frick® Factors obtain parts fast. Prompt and accurate service is our standard. We also offer a priority order service to expedite in-stock parts orders when same-day shipment is required.

A GLOBAL LEADER

The Frick Brand is produced by Johnson Controls, a global diversified technology and industrial leader serving customers in over 150 countries. Johnson Controls serves these markets through three business units; Building Efficiency, Automotive Experience, Power Solutions.

Our Values

- Integrity
- Customer Satisfaction
- Employee Engagement
- Innovation
- Sustainability

Our commitment to sustainability includes our products, services, and operations. We believe in efficient use of resources around the world. We are committed to delivering value and making our customers successful.

Our 168,000 employees create quality products, services and solutions to optimize energy and operational efficiencies of buildings; lead-acid automotive batteries and advanced batteries for hybrid and electric vehicles; and interior systems for automobiles.



Building Efficiency is a leading provider of equipment and controls for industrial refrigeration, heating, ventilating, and air-conditioning, as well as security systems for buildings.

Automotive Experience is a global leader in automotive seating, overhead systems, door and instrument panels, and interior electronics.



Power Solutions is the leading supplier of lead-acid batteries for virtually every type of passenger car, light truck, or utility vehicle as well as the leading independent supplier of hybrid systems.





**RWF II and RXF Rotary Screw Compressors
Quiet! Reliable! Efficient!**

Frick® RWF II and RXF Rotary Screw Compressors... leading the food and beverage industry with the most innovative and broadest product range available for industrial applications.

- **Variable volume ratio** for maximum efficiency
- **Infinite capacity control** to match changing loads... exactly!
- **Smart Series™ Motors** are NEMA premium efficient, low noise. Standard on Frick® compressor packages.
- **Flange mounting** eliminates troublesome field alignment between low-noise motor and compressor
- **Factory-mounted starter** simplifies electrical installation
- **Cold-start valve** provides oil pressure without the need for a pump
- **Lower leakage potential** because of fewer threads, less fittings and welded connections
- **Oil Cooling** by EZ-Cool™ Liquid Injection using a motorized expansion valve controlled by the Frick® Quantum™HD for optimum discharge temperature control; or by Thermosyphon which uses a plate and shell vessel to cool the oil with no compressor capacity lost or compressor power penalties incurred.

QUANTUM™HD CONTROLLER Heavy-Duty Performance in High Definition

Our new HD provides a large 15" display that is easy to read and navigate, just like the web. For today's personal computer user, the look and feel of Quantum™HD is second nature.

The Quantum HD provides three levels of access based on the users' experience. The PIN based security system means no sharing of pass codes. When the operator logs in, they are taken directly to their access level.

- Four user-defined capacity control modes for a wide application range
- Built-in diagnostic functions simplify troubleshooting
- Quantum™HD has on-screen calibrations and operator-friendly graphics
- Real-time and historical trending
- Smart safeties mean trouble-free operation
- Uses Ethernet for high-speed communications
- Backward compatible to Plus, Quantum, and Quantum™LX with ethernet controllers with serial communication
- Industry standard serial communication protocols: Frick® ASCII · Allen-Bradley® DF1 Serial, Modbus ASCII · Modbus RTU
- Ethernet: Modbus TCP and Allen-Bradley Ethernet IP · Web accessible





Frick® PowerPac™ ...Your next refrigeration plant should be easy to buy, easy to install and easy to operate!

Frick® PowerPac™ reduces the need for field labor. Frick® compressors, heat exchangers, evaporators, and condensers come in a compact package controlled by Frick® Quantum™HD controls and Frick® “turnkey” software.

Your Frick® PowerPac™ puts advanced heat exchanger technology to work for reduced refrigerant usage and maximum operating efficiency.

Reduces the requirement for a Process Safety Management (PSM) program.

Frick® PowerPac™

- Less jobsite labor means lower cost
- Optimized design means fewer welds
- “Factory Built” controlled environment; site delivered ready to operate
- Simplified electrical hookups
- Process side uses pumped glycol
- Freeze protection from 3-Directional expansion
- Plate and frame heat exchanger means less refrigerant charge

Unit-Mounted Solid-State Starter or Variable Speed Drive...Why?

- Lower installation costs
- Less mounting space
- Extended motor life and improved system integrity because it’s factory wired
- Superior motor overload protection
- Main circuit breaker disconnect provides immediate shutdown protection at the compressor.

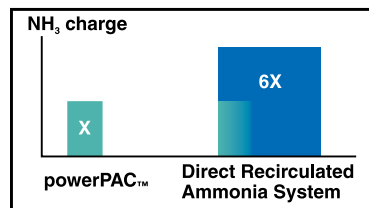

Vyper™ Variable Speed Drive gives you the kind of control you need today, to respond to the unique load demands of your Process Cooling Requirements.

There are many processes that could benefit from the use of the Vyper™ VSD. Some examples are:

- Carbonated Beverage • Cold Storage • Meat Processing • Dairy • Poultry Processing • Industrial Bakeries • Seafood • Fruits & Vegetables • Breweries • Ice Making

Contact your Frick® sales representative to better realize the potential of this technology when applied to your process.





A smart, environmentally friendly way to upgrade your facility and reduce your carbon footprint!

Frick SmartPac™ Heat Pumps

SmartPac™ Heat Pumps capture the heat from your ammonia refrigeration system that is normally rejected to the atmosphere. SmartPac™ then transforms this valuable resource into hot water that can then be utilized throughout your industrial facility.

SmartPac™ enables you to make more efficient use of your ammonia refrigeration system ... bottom line ... lower utility bills and a reduced carbon footprint.

Frick® SmartPac™ – Easy to Install; Easy to Own

Frick screw compressors, heat exchangers, pressure vessels and controls all come together in a compact package ready to install.

Advanced heat exchanger technology increases operating efficiency with a reduced refrigerant charge.

When installed by a Frick Factor, get a 3-year warranty. No worries start saving \$\$ now.

SmartPac™ Applications

- Beef
- Poultry
- Dairy
- Brewery
- Prepared Foods
- Ice Rinks
- District Heating

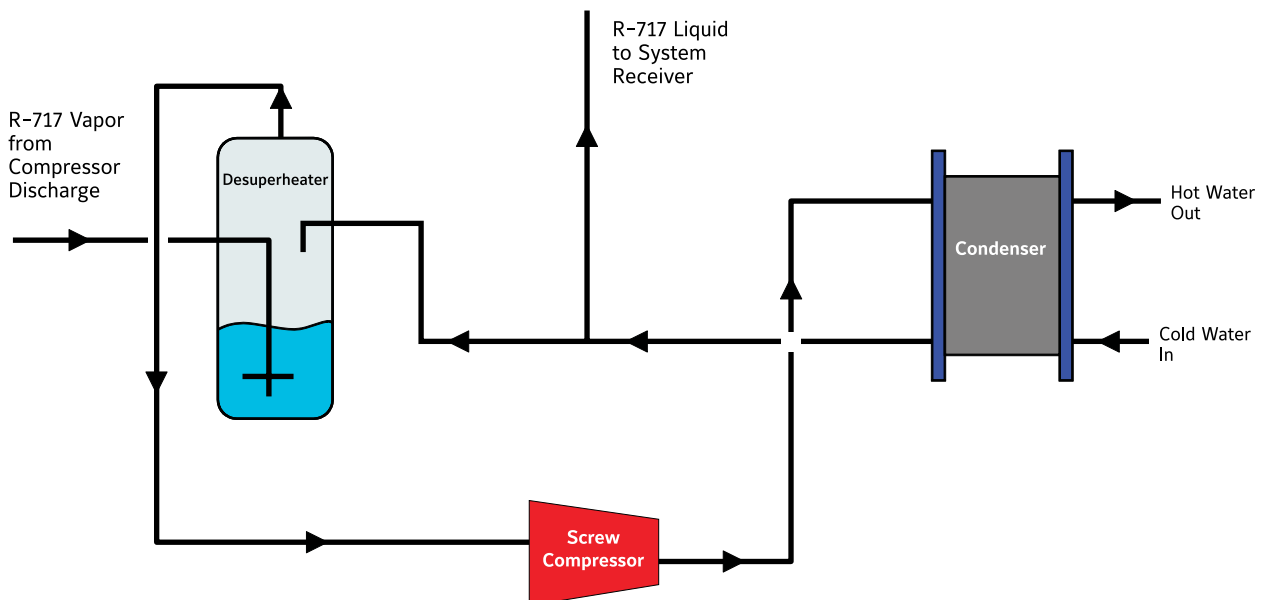



Sanitary conditions, compliance with regulations and the demand to deliver a quality product are all part of the success equation. Frick® AcuAir® systems are precision-engineered and painstakingly built to the high sanitary standards of food processors and help you meet the requirements of the United States Department of Agriculture.



Frick AcuAir® products are the best solution for clean, conditioned air!

Custom Engineering

The extensive experience of Frick AcuAir® and the array of unit options allows us to customize a unit for your specific application..

Frick AcuAir® Hygienic Air Units

Process Room Control of Temperature, Pressure, and Filtration, Creating a Safe, Sanitary Food Processing Environment

- Hygienic air conditioning
- Rooftop installation
- Engineered to your specific sanitary requirements



Makeup Air Units

Whether your application requires simple fresh-filtered air with little temperature conditioning or specific volumes of tempered air, the AcuAir applications team knows just the questions to ask in order to provide you with your most economical solution.



AcuAir products controlled by Quantum™LX technology provide access for monitoring and control, using the web browser of any connected network computer or a laptop at the unit. Simply type in the Unit's IP Address for easy access. The remote mounted System Interface Panel (optional & shown here) can also be used for quick easy access to monitor

and control your AcuAir units. The System Interface Panel will also provide access to any Quantum™LX control panel (compressor, evaporator, condenser/vessel) on the network from one convenient, central location.

Designed for Internal Washdown

Floor drains are provided throughout the unit that are piped to the exterior of the unit base. Under the cooling coil and downstream, the unit is provided with recessed stainless steel drain pans that are double-sloped for positive water drainage. Internal wiring and motors are also engineered for washdown duty.





A Frick® heavy-duty evaporator means:

- Reliable heat transfer for continuous operation at all temperature levels
- Design flexibility in geometry, fan selection, and construction materials.

Innovative solutions driven by your application needs!

- CleanCoil™ hygienic fin design
- Fully welded hygienic drain pans
- Vari-Fin frost management design
- Full coverage drain pans

RTF Rooftop Freezer Systems

Penthouse Unit Features:

- 4" (R-32) or 5" (R-41) urethane foamed-in-place wall panels.
- Exterior painted, stucco-embossed steel panel.
- Large service doors with heated seals.
- OSHA guards at fan inlet.
- Fan motor service rail.
- Interior maintenance lighting.
- Refrigerant and drain lines extend through the insulated enclosure.
- Insulated drain pan – with or without hot gas pan coil. Interconnecting hot gas piping not included.
- External electrical control panel (Optional).
- Frick Variable Frequency Drive starters are available

Frick Quantum™LX controllers provide the right solution for efficient capacity control.

- Flexible defrost-sequencing control platform
- Control up to 30 evaporators from each Quantum™LX graphical interface
- Remote terminal boxes minimize wiring requirements and reduce installation expenses.

And ... for extremely large facilities, link several Frick® Quantum™LX control panels together to manage all of the evaporators at the same time.



The Evaporator System Includes:

- Coils constructed of stainless steel tube and aluminum fins or all hot dip galvanized steel.
- Direct-drive cast aluminum, nonoverloading axial propeller fans. Standard motors are TEFC, 1160 or 1750 RPM.
- Air or hot gas defrost coil designs



Easy Maintenance

- Internal Access – The interior of the unit is spacious and easily accessible via multiple large hinged access doors for adjusting the float valve, cleaning the strainer, or flushing the basin.
- Basin Sweeper System – The basin contains an optional piping system to sweep away sediment.
- Harmony™ Removal System – Water distribution branch removal system that requires no tools.

Reliable Year-Round Operation

- Drive System – The fans, motor, and drive system are located to protect them from moisture, condensation and icing. Backed by a 5-year fan drive and motor warranty, these units are suitable for year-round operation.
- HDGAF Coil – The coil is hot dip galvanized after fabrication.

Low Installed Cost

- Support – All models mount directly on two parallel I beams and ship complete with motors and drives factory installed and aligned.
- Modular Design – Large models ship in multiple sections to minimize the size and weight of the heaviest lift, allowing for the use of smaller, less costly cranes.

Green (Energy Saving)

- PE VFD Motors – Fan motors are premium efficient inverter duty.
- VFD Starters – Frick Variable Frequency Drive fan starters with integrated pump starters are available
- Design – Evaporative condensers lower the condensing temperature saving up to 15% compared to a traditional condenser.



The Frick Quantum™LX Condenser Control Panel

- Multi-step head pressure control
- Graphical operator interface (GOI) simplifies operator training
- Menu driven control-sequencing options
- Vessel level control to manage engine room needs



PRESSURE VESSELS

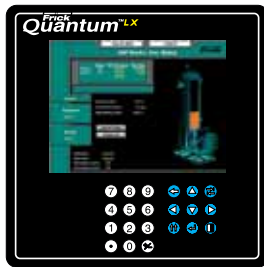

Accumulators

Vertical accumulators with or without coils.

Intercoolers

Vertical intercoolers with or without coils..

Receivers

- Horizontal and vertical high-pressure receivers.
- Horizontal and vertical thermosyphon receivers.
- Vertical high-pressure thermosyphon receivers.

Oil Pots

Horizontal oil pots.

Economizers

Flash type and shell-and-coil type.

Surge Drums

Horizontal surge drums with either single-flow or dual-flow.

Surge Drum Packages

Horizontal vessel design with sufficient room for plate and frame heat exchangers mounted below vessel.

Special Vessels and Packages

Frick® manufactures vessels and packages customized to specific application and design requirements.



Liquid Recirculator Vessels and Packages

Horizontal and vertical recirculator packages and vessels from 24 to 96 inch outside diameter. Offered with either mechanical seal or semihermetic style pumps, packages are completely factory piped and come standard with a 3-inch float column and 3 level eyes. Standard ammonia packages include an oil pot. Options include unit-mounted controls and starters, liquid-level control systems, oil pot heaters, variable speed drives, and liquid makeup assemblies (shipped loose).

HEAT EXCHANGERS

Lazerweld semi-welded plate and frame heat exchangers provide an efficient heat transfer solution for ammonia refrigeration. Small approach temperatures result in more capacity using less energy. There are 14 models that are easily expandable in a small space saving footprint.

Packaged LaZerWeld Chilling Solution

Packaged Lazerweld evaporators combine the efficiency of the Lazerweld heat exchanger with the convenience of a complete packaged solution that minimizes piping and electrical requirements at the time of installation.

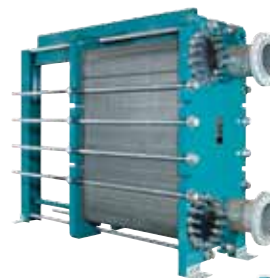



Frick custom engineered control systems are tailored to your individual requirements and are used on all types of new and existing Industrial Refrigeration applications.

- Custom solutions for any refrigeration application
- All setpoints password-protected with supervisor-assigned accessibility
- Open architecture
- Nonproprietary hardware and software

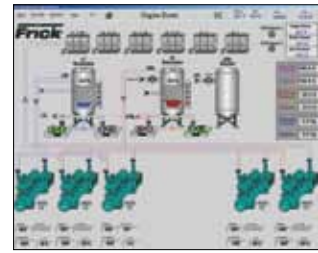

Engine room overview screen

Opto 22 • Allen-Bradley®
RSView®32™ • Wonderware® In-Touch®



- Remote monitoring
- Data logging and trending
- Report generation and printouts

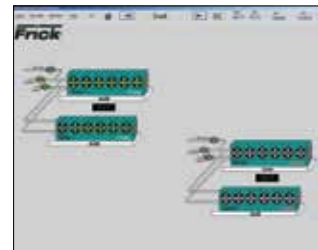

Individual or group evaporator overview screen

- All systems are protected by a NEMA 4 enclosure. NEMA 4x available as an option.

- Unit-Mounted Starters and Controls for ease of installation and accessibility
- Standard and Custom Variable Speed Starting Solutions



Single Source Industrial Refrigeration Solutions !

Heat Exchangers

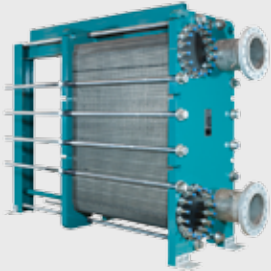

Packaged Equipment



Hygienic Air Units



Vessels



Controls



Evaporators



Compressors



Condensers



Johnson Controls Inc.
100 CV Avenue
Waynesboro, PA 17268-1206 U.S.A.
Tel: 717-762-2121 • Fax: 717-762-8624
www.jci.com/frick



Form 020.001-SG1 (2014-03)
Supersedes: 020.001-SG1 (2012-05)
Subject to change without notice
Published in U.S.A. • 03/14 GUI 1M

© 2014 Johnson Controls Inc. – All rights reserved
PRINTED ON CHORUS ART GLOSS TEXT
CONTAINS 25% POST-CONSUMER WASTE

