

REDI CONTROLS, INC.

Installation, Operation & Maintenance Manual

Literature File No. 1116-02

Redi-Purge™ Model PRG-11/123-C3 Microprocessor Controlled

Ultra High Efficiency



Patent No. 4,169,356

Purge Unit for Low Pressure Chillers

Manufactured in accordance with
ASHRAE Guidelines 3-1990 Sec. 4.7 and
Standard 15-1992 Sec. 8.3, 8.7 and 10.4



ETL Listed
3104248

Revised Technically as of July 1, 2002
This Copy was Printed on May 8, 2007
© 1994 REDI CONTROLS, INC., GREENWOOD, INDIANA

GENERAL INFORMATION

YOU ARE URGED TO READ THIS MANUAL COMPLETELY BEFORE INSTALLING AND/OR OPERATING THIS UNIT

Upon Receiving Your Unit

Inspect the unit for possible damage caused during shipping. **Contact Equipment Servicing before attempting to use a damaged unit.**

Warnings and Cautions

NOTE: *Warnings and Cautions appear in highlighted boxes as illustrated below at appropriate points throughout this manual. Give special attention to these items.*

Warnings: Provided to alert you to potential hazards that could result in serious personal injury and damage to your equipment. Warnings may appear in this manual or on the equipment. Heed all Warnings.

Cautions: Designed to alert you to situations that may result in damage to your equipment.

Personal safety and the proper operation of your equipment require strict observance of these precautions.

EQUIPMENT SHOULD BE INSTALLED AND OPERATED ONLY BY QUALIFIED PERSONNEL

Warning: Certain servicing procedures may expose you to harmful materials and dangerous conditions. To minimize the possibility of injury, follow safety procedures and instructions described in this manual, on product labels and in material safety data sheets provided.

NOTE: *The manufacturer has a continuous equipment improvement policy and reserves the right to change specifications and design of its products without notice.*

Table of Contents

GENERAL INFORMATION	3
Upon Receiving Your Unit.....	3
Warnings and Cautions.....	3
INSTALLATION	9
Before You Start	9
When using on an R-123 Chiller.....	9
Purge Specifications.....	10
Contents of the Purge Installation Kit	10
Field-Provided Items.....	10
Preliminary "Kit" Inspection	10
Removing Old Purge Unit	11
Preparation	11
Removal Procedure	11
Installing the Unit	12
Location.....	12
Mounting.....	12
Figure 1 - Connection sizes and locations	12
Refrigerant Line Connections	13
Auxiliary Condenser and Heat Recovery Units.....	13
Purge Vapor Inlet Line	13
Vapor Inlet Filter-Driers	13
Liquid Refrigerant Return Line.....	14
Refrigerant Line Installation Procedure.....	14
Pumpout Compressor Discharge Vent Line.....	15
Electrical Connections	15
Chiller "Run Signal" Wiring.....	15
Preliminary Checkout and Power-Up	15
SYSTEM COMPONENTS	17
Figure 2. - Major Components	17
Figure 3. - Electrical Control Box Exterior	17
Figure 4. - Electrical Control Box Interior	17
Figure 5. - Flow Schematic and component location	18
OPERATIONAL OVERVIEW	19
Air-Cooled Condensing Unit.....	19
Operating cycle.....	19
Figure 6. - Refrigerant Circuit Schematic	19
Purge Tank.....	20
Purge and Refrigerant Drain Back Function.....	20
Pumpout System	20
Filter Driers (and Moisture Monitoring)	20

Vapor Inlet Filter-Driers.....	20
Security-Lock	20
Optional Accessories	21
1. Emission Collection Canister saturation alarm (option)	21
2. Chiller mounted condenser temperature sensor TS3 (option)	21
3. Chiller evaporator pressure Pre-Alarm PS1 (option)	21
System Components	21
Purge Control Panel	21
Microprocessor Circuit Board.....	22
Compressor unit (C1)	22
Pumpout Compressor (C2).....	22
Temperature Sensor (TS1).....	22
Temperature Sensor (TS2).....	22
Pumpout Solenoid Valves (L1 & L2)	22
Drain solenoid (L3)	22
Liquid Level Switch (LS1) - (see Figure 5 on page 18 for location).....	22
Remote "Purge Fault" Alarm Relay (RY7).....	23
Auxiliary Relay (RY8).....	23
Terminal Block (TB1)	23
Control Transformer (T1).....	23
Constant pressure expansion valve.....	23
QUICK START - OPERATION	24
Quick Start Introduction	24
1. Press "SET CLOCK" Keypad Switch	24
2. Select Desired Operating Mode	25
Security-Lock	25
Setting Operational Parameters	26
Purge Fault setting.....	26
Fault BYPASS setting	26
Drain Cycle setting (sets LS1 liquid level switch make/break hysteresis)	27
Dip Switch S1 Settings	28
Dip switch S1 Security Lock.....	28
Dip switch S1 Canister Alarm	28
Dip switch S1 Canister Alarm (Purge Lock-Out Option)	28
Dip switch S1 Evaporator Pressure Pre-Alarm.....	28
Dip switch S1 Condensing Temperature Option	28
Microprocessor Overview	28
Introduction.....	28
Safety Features	29
Maximum Allowable Pumpout Time Exceeded (PURGE FAULT)	29
Drain Operation (DRAIN FAULT)	29
Sensor Operation (SENSOR ERROR).....	29
Operating Modes ("Manual" - "Auto" & "Adaptive")	29
Figure 7. - Purge Control Panel	30
LCD Display	30
Keypad Switches	30
"SET CLOCK" Keypad Switch	31
"STOP" Keypad switch	31

“MANUAL” Keypad switch (for additional information see “Operating Modes” page 29)	31
“AUTO” Keypad Switch	32
“ADAPTIVE” Keypad Switch (for additional information see “Operating Modes” page 29)	32
“SENSORS” Keypad Switch	33
“SETTINGS” Keypad Switch	33
“BYPASS” Keypad Switch	33
Exiting Fault “BYPASS” Mode	34
“DIAG.” Keypad Switch	34
“LOGs” Keypad Switch	36
Log 1 - 30 day "sliding window" average purge pumpout time (chiller OFF)	36
Log 2 - 30 day "sliding window" average purge pumpout time (chiller on)	36
Log 3 - Pumpout time that has occurred during last 24 hour “sliding window” period	37
Log 4 - Pumpout time during the 1st three(3) hours following last chiller shutdown	37
Log 5 - Average daily chiller RUN time for last 30-day period	37
Log 6 - Total accumulated purge condensing unit “RUN” time since installed	37
Log 7 - Total accumulated purge “pumpout” time since installed	38
Log 8 - Average daily pumpout time for last 30 day period	38
Log 9 - Number of Adaptive or Auto run cycles “Chiller ON” (maximum 8 cycles per day)	38
Log 10 - Number of Adaptive only run cycles “Chiller OFF” (maximum 8 cycles per day)	38
Log 11 - Interval Log - Total chiller run time since log last reset	39
“CLEAR LOGs” Keypad Switch	39
“RESET” Keypad Switch	40
“STATUS” Keypad Switch	40
“<“or“>“ CURSOR MOVEMENT Keypad Switches	40
Informational Displays	40
STATUS Display	40
LOGs Display	41
Log 1 - Purge 30-day average pumpout time while chiller is off (Hrs & Min.)	41
Log 2 - Purge 30-day average pumpout time while chiller is on (Hrs & Min.)	41
Log 3 - Purge Pumpout for Last 24 Hours (Hrs & Min.)	41
Log 4 - Pumpout time first 3 hours after last chiller shutdown (Hrs & Min.)	42
Log 5 - Last 30-Day Chiller Run Time (daily average) (in hours)	42
Log 6 - Total Purge Condensing Unit Run Time (in hours)	42
Log 7 - Total Cumulative Pumpout Time (in hours and minutes)	42
Log 8 - 30-Day Average Pumpout Time per day (Hrs & Min.)	42
Log 9 - Number of Adaptive or Auto run cycles “Chiller ON” (maximum 8 cycles per day)	42
Log 10 - Number of Adaptive only run cycles “Chiller OFF” (maximum 8 cycles per day)	43
Log 11 - Interval log (in days, hours and minutes)	43
“SENSORS” Display	43
(Superheat) Refrigeration Compressor Suction Temperature	43
(Evaporator) Purge Tank Evaporating Temperature	43
(Liquid Level Status) Drain Status	43
“MISCELLANEOUS” - Informational Displays	44
Pump-out Display	44
DRAIN BACK EQUALIZATION CYCLE	44
Sensor Error Displays	45
Fault Indications	46
PURGE FAULT	46
DRAIN FAULT	46
BATTERY FAULT	46
MAINTENANCE	47
Periodic Maintenance	47
Weekly	47
Semi-Annually	47
Moisture Monitoring	47

Table 1 - Determining Refrigerant Moisture Content	48
Filter-Drier Replacement.....	49
(A) Streamline-One-Shot™ vapor inlet line filter-driers:	49
(B) Optional liquid return line filter-drier: (if used)	49
Purge Tank Service	49
Water Removal.....	49
Purge Tank at a Positive Pressure.....	49
Purge Tank at a Negative Pressure	50
Figure 8. - Electrical Schematic (for York Chillers see Figure 8A).	51
Figure 8A. – Wiring For YORK “Optiview” and “Micro Panel” controls	52
Trouble Shooting	53
Troubleshooting Chart.....	53
Troubleshooting Chart (continued)	54
Purge Refrigeration System Diagnostic Procedure	55
Evaporator Pressure CPEV	55
Temperature Sensor TS1	55
Temperature Sensor TS2	56
Optional Temperature Sensor TS3.....	56
Checking for Calibration	57
Table 2. - Sensor Temperature -vs- Resistance	57
SERVICE TIPS.....	58
Purging after Internal Chiller Repairs or Servicing	58
Bypassing Pumpout Flow Restrictor.....	59
Moisture monitor.....	59
Air-Leak Rate	59
Locating a leak	60
Using the "Interval Log"	60
Data Logging (see Graph/Log Charts for copying on pages 62-66)	61
3 Graph & Log - Purge Pumpout Time Last 24 Hours	62
3 Graph & Log - 30-Day Average Purge Pumpout Time Per Day.....	63
3 Graph & Log - 30-Day Average Purge Pumpout Time - Chiller running	64
3 Graph & Log - 30-Day Average Purge Pumpout Time- Chiller Off.....	65
3 Graph & Log - First 3 Hours Purge Pumpout Time after Chiller Shutdown.....	66
Equipment Warranty.....	68

INSTALLATION

Before You Start

Caution: Federal Refrigerant Recycling Regulations require that the chiller, during servicing, be either completely evacuated or pressurized to atmospheric pressure (0 psig) prior to opening the refrigerant circuit to the atmosphere. Failure to comply, or using means other than heat to elevate refrigerant pressure, violates Section 608 of the Clean Air act.

The purge system is designed to automatically remove non-condensables from low pressure centrifugal chillers using CFC or HCFC refrigerants. The Purge, together with the emission collection canister, is designed to assure the highest efficiency in preventing refrigerant from escaping to the atmosphere.

This section discusses the proper procedures for replacing the purge unit on an existing R -11 or R -123 low pressure centrifugal chiller. This purge unit is designed for application on water cooled centrifugal chillers, either pneumatically or electrically controlled.

NOTE: *The Purge Unit is not designed for application on air cooled chillers.*

When using on an R-123 Chiller

Notice: The standard purge unit is manufactured with solenoid valves having elastomer material compatible with **R-11** refrigerant. If the unit is to be used in connection with a Chiller operating on an **HCFC-123** refrigerant, then the pumpout solenoid valve elastomers ***must*** be replaced with elastomers made of a material compatible with **HCFC-123**.

An elastomer Kit is available for converting a standard **R-11** unit for use with **HCFC-123** refrigerant. For additional information, or to order a conversion kit, contact Equipment Servicing.

Warning: Installing or servicing refrigerant support equipment can be hazardous due to system pressures and dangerous voltages. Only qualified service personnel should work on such equipment.

Purge Specifications

Electrical Power Requirements: 103-127 VAC, 50/60 Hz., 1-Phase, 15 Amp Fused Circuit

Remote Alarm Relay (RY7) Contact Rating: (Form C) 120 VAC; 15 Amp

Operating Environment: 40°F to 120°F, 5% to 95% relative humidity

Storage Environment: -20°F to 120°F

Dimensions (approximate): 19" height x 25" length x 14" depth

Refrigerant Charge: 0.5 lbs R-134a

Weight (approximate): 110 pounds

Shipping weight (approximate): 120 pounds

NOTE: *The purge unit comes equipped with a RS 232C communication interface.*

Contents of the Purge Installation Kit

Each "kit" includes: One Purge Unit;
One Installation, Operation and Maintenance Manual;
One, one-pass Filter/Drier set;
One 1/2-inch ball valve;
One moisture indicator.

Field-Provided Items

To be furnished by the installer: Purge Unit mounting hardware;
Electrical conduit and wiring materials;
1/4-inch copper refrigerant tubing;
1/2-inch copper refrigerant tubing;
3/8-inch copper refrigerant tubing;
Fittings.

Preliminary "Kit" Inspection

Before installing the Purge Unit check the data on the purge unit nameplate and verify that the model number and voltage are correct for the application.

It is recommended that the sealed refrigeration section of the new purge unit be verified for proper operation prior to actual installation. The unit can be easily bench -tested utilizing a temporary 110 VAC power connection.

Removing Old Purge Unit

Replacing the existing purge system on older centrifugal chillers with the new Purge Unit requires that the existing purge system be completely disconnected and removed. Before proceeding with the retrofit it is important that the installer thoroughly review and understand the following instructions for preparing the chiller to remove the old purge system.

Preparation

WARNING: Be sure to open and lock-out all electrical disconnects to prevent possible injury or death cause by electrical shock.

1. Terminate chiller operation and disconnect all electrical power to the chiller and old purge unit.
2. Turn off water supply to purge system, where applicable.
3. Close the angle valve on the condenser to isolate inlet to purge system.
4. Close the liquid return angle valve on the evaporator to isolate outlet of purge system.

NOTE: *It is not necessary to remove chiller's refrigerant charge to retrofit a new purge unit.*

Removal Procedure

Disconnect and remove all existing purge unit electrical connections from both the old purge unit and chiller control panel. Disconnect the water lines to the old purge tank, if applicable, and cap off or remove. These water lines are no longer needed since the new purge system does not require the use of water.

Disconnect the copper line from the purge solenoid valve (if present) on the condenser. Temporarily cap off the flare fitting on solenoid valve. If there is no solenoid valve on the condenser, remove copper line and cap off condenser fitting as quickly as possible to minimize air leakage into chiller. This fitting will be used later on. Also disconnect the copper line from the purge compressor inlet, remove and discard tubing.

Disconnect the 1/4-inch copper liquid return line from the liquid return valve on the evaporator and from the purge tank, remove and discard tubing. Also, if the purge tank relief is piped to the rupture disc vent, disconnect and remove pipe. Unbolt old purge base from its mounting and remove.

WARNING To avoid possible injury or damage to equipment, be sure to have appropriate equipment available to lower the purge unit from the chiller (if necessary).

Installing the Unit

Installation of the new purge unit requires several wiring and hardware modifications. To insure proper installation, it is important that the installer thoroughly read and understand the following instructions.

NOTE: *The installer should record all changes and modifications made to the chiller during installation and provide a copy for inclusion with the maintenance records of the chiller.*

Location

The purge unit is not location sensitive. The only limitation is that it must be higher than the liquid refrigerant level in the chiller evaporator. The unit may be located at any convenient location on or near the chiller. If you are replacing an old unit, it can be located in the same place as the existing system.

Mounting

In a few cases, some fabrication may be necessary to mount the new purge. Since the purge comes mounted on its own integral base, field fabrication should be minimal.

WARNING: The purge weighs approximately 110 lbs. To avoid possible injury or damage to equipment, be sure to have appropriate equipment available to raise the unit into place.

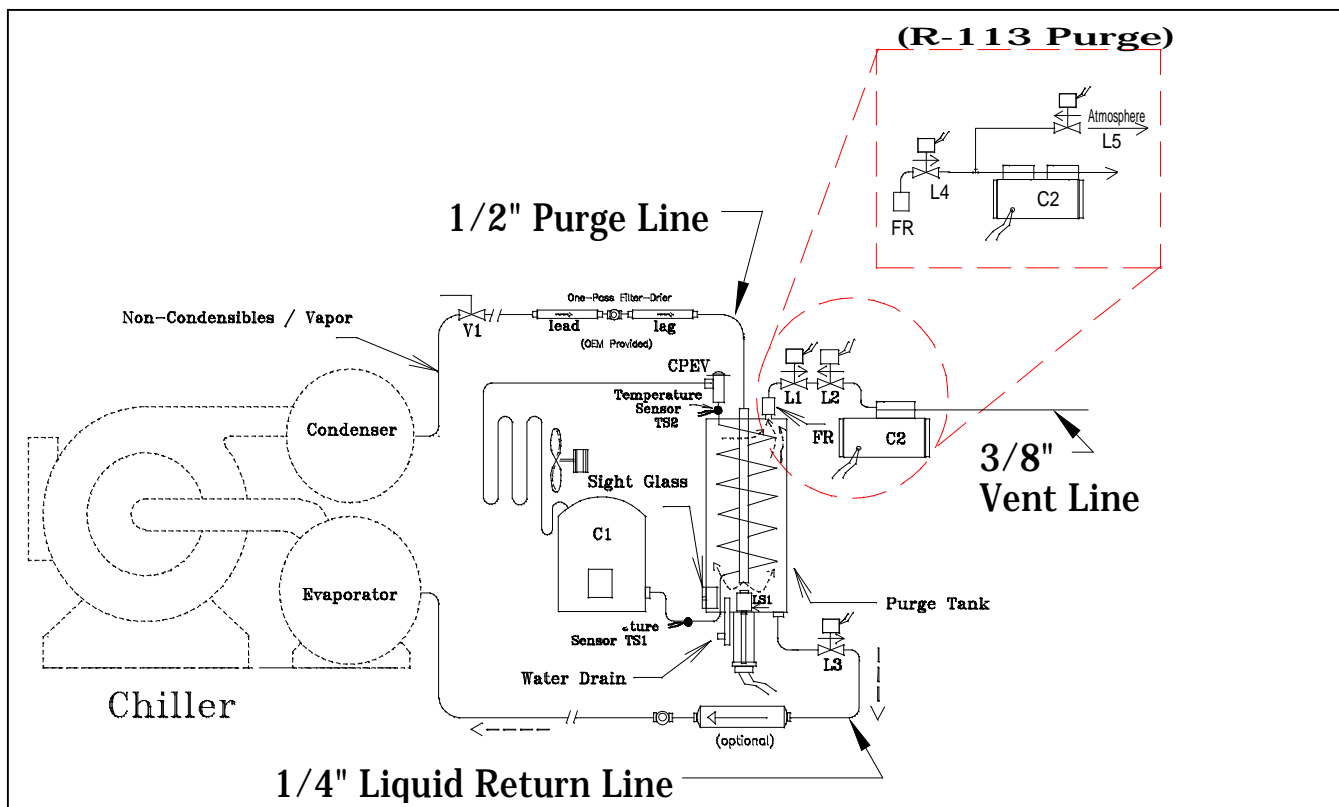

Figure 1 - Connection sizes and locations

Refrigerant Line Connections

The purge requires three separate refrigerant line connections (see Figure 1 on page 12):

1. A 1/2" purge inlet line between the purge tank and the condenser purge outlet. The same condenser outlet the old purge used.
2. A 1/4" liquid return line from the purge tank drain solenoid valve to the liquid return angle valve on the evaporator. (*Can be same valve used by old purge unit drain back line provided it enters Evaporator above liquid refrigerant level - see **NOTE** on next page*).
3. A 3/8" vent line from the discharge port on the pumpout compressor to the emission collection canister, or the rupture disc vent line or direct to the outdoor atmosphere.

Auxiliary Condenser and Heat Recovery Units

When the purge is applied to a heat recovery unit or a unit with an auxiliary condenser, some additional piping considerations are required:

1. The purge unit vapor inlet line must be connected to both the cooling and auxiliary heat recovery condensers. The entire length of both lines must slope toward either the purge unit or condensers. **Avoid sagging of the tubing where pockets of liquid refrigerant can condense and accumulate.**
2. Shutoff valves (1/2 inch ball valves) must be provided at both condensers so the non-operating condenser can be isolated.

Purge Vapor Inlet Line

The purge vapor inlet line runs between the original purge pickup point on the condenser shell (this point is typically beneath an internal baffle plate inside the condenser), and the purge inlet connection on the purge tank. This line must be 1/2-inch refrigeration-grade copper tubing.

The existing shutoff valve, or solenoid valve must be removed and discarded, and the 1/2-inch line adapted to connect direct to the condenser purge pickup fitting. Chiller manufacturers have generally utilized three different size purge connections, 1/2-inch NPT, 3/8-inch NPT, and 1/4-inch NPT. In any case, the 1/2-inch line can be easily adapted to connect to any of the three connections.

Vapor Inlet Filter-Driers

The two (2) Streamline™ one pass filter-driers and moisture indicator provided with the purge **MUST** be installed in the **vapor inlet** line between the chiller and the purge unit to prevent buildup of acid and particulates in the purge tank (see Figure 1 on page 12). **DO NOT OMIT OR SUBSTITUTE!**

Caution: These are special filter-driers specifically designed to clean and dry the refrigerant vapor in a single pass, thus protecting the purge unit from contaminants and corrosion.

Liquid Refrigerant Return Line

The liquid refrigerant return line runs between the evaporator's original liquid return angle valve and drain back solenoid valve L3 (see Figure 1 on page 12) or the outlet of the optional liquid line filter-drier, if used. Use 1/4" refrigerant-grade copper tubing.

NOTE: The Liquid Refrigerant Return Line MUST connect to the chiller evaporator ABOVE the Liquid Level. **THE PURGE UNIT WILL NOT DRAIN PROPERLY** if the line is connected to a point below the liquid refrigerant level (see illustration to the right).

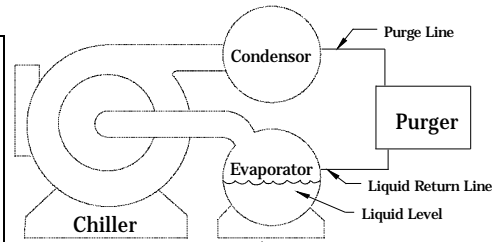

Refrigerant Line Installation Procedure

It is recommended that the following procedures be followed when making the purge refrigerant line connections.

Caution: Federal Refrigerant Recycling Regulations require that the chiller, during servicing, be either completely evacuated or pressurized to atmospheric pressure (0 psig) prior to opening the refrigerant circuit to the atmosphere. Failure to comply, or using means other than heat to elevate refrigerant pressure, violates Section 608 of the Clean Air act.

1. First, install the 1/4-inch liquid refrigerant return line. Do Not open the liquid return valve on the evaporator at this time.

NOTE: Avoid sagging of the tubing to insure free gravity flow of liquid refrigerant back to the chiller.

2. If used, install the optional liquid line filter-drier and the moisture indicating sight glass as shown in Figure 5 on page 18. The sight glass should be installed so the viewing area is tilted slightly downward just enough to assure liquid contact with the moisture sensing element. If not used, connect return line direct to drain back solenoid valve L3.
3. Install the 1/2-inch purge line and vapor line filter-drier set with the moisture indicator sight glass (see Figure 5 on page 18) from the purge unit to the condenser purge fitting. Start by making the connection at the purge first. Next, determine what fitting will be used to make the connection at the condenser. Cap off the flare end of fitting with a flare cap.
4. Remove the existing purge solenoid valve or angle valve from the condenser purge fitting and as quickly as possible screw in the new fitting with cap.
5. Finally, cut the 1/2-inch purge line to the proper length. Install the 1/2-inch OD ball valve in the 1/2-inch line as close to the condenser connection as possible. Cut and flare a short section of 1/2-inch tube (approx. 4 to 6 inches long). Slip on the flare nut and sweat tube to inlet end of the ball valve. Now again, as quickly as possible remove the flare cap from the purge outlet fitting and connect the 1/2-inch line with ball valve.
6. Open purge isolation valves at this time.

NOTE: *The entire length of the vapor line, including the in-line filter-drier set, must slope toward either the purge inlet or the chiller condenser. Avoid sagging of the tubing where pockets of liquid refrigerant can condense and accumulate.*

Pumpout Compressor Discharge Vent Line

When venting the pumpout compressor to the emission collection canister, or to the outdoor atmosphere, or the chiller rupture disc vent line, it is important to use 3/8-inch line size to minimize pressure drop. For proper operation the pumpout compressor discharge must be at atmospheric.

Electrical Connections

WARNING: Be sure to open and lock-out all electrical disconnects to prevent possible injury or death caused by electrical shock.

The unit requires three power connections to the chiller's control circuit. The electrical requirement is:

103-127 VAC, 50/60 Hz., 1-Phase 15 Amp Fused Circuit

NOTE: *Use Class 1, 14 AWG copper wire and metal conduit. All field installed wiring must comply with all applicable NEC and local electrical codes.*

Chiller “Run Signal” Wiring

1. For the **typical** purge unit installation refer to Electrical Schematic (**Figure 8**) for appropriate chiller **“Run Signal”** wiring.
2. However, if the purge unit is being installed on a **YORK** chiller with either a **“Micro-Panel”** or **“Optiview”** panel you **MUST wire the chiller “Run Signal”** to the purge unit according to Electrical Schematic (**Figure 8A**).
3. This "Run" signal can be obtained by tapping into the chiller's hour meter power source, or any other source that can provide a 115 VAC signal whenever the chiller is running. This signal triggers the Circuit Board run input opto-isolator which enables purge operation.

WARNING: Failure to properly wire the chiller “Run Signal” on YORK chillers with “Optiview” and “Micro-Panel” controllers could result in serious damage to the chiller.

Preliminary Checkout and Power-Up

1. Connect the 115 VAC main “hot line” from the fused purge output in the chiller control panel to TB1-1 in the purge unit electrical box, and the 115 VAC “neutral” to TB1-6 (see Figures 8 and 8A on pages 51 and 52 for location of terminal connections). This power line provides 115 volt power to the purge condensing unit, pumpout compressor, pumpout solenoid valves and the control transformer.

Preliminary Checkout and Power-Up (continued)

2. Check the Unit fuse (F1) to insure that it is properly installed (see Figure 4 on page 17).
3. Check to make sure that all internal connections are secure.
4. Apply power to purge unit and measure voltages at TB1 -1 & TB1-6 and TB1-3 & TB1-6 (see figures 8 and 8A on pages 51 and 52).
5. The voltage between TB1-1 & TB1-6 should be 103 to 127 VAC, and between TB1 -3 & TB1-6 should be 0 volts with chiller "OFF" and 103 to 127 VAC when chiller is "ON".
6. Check purge control panel LCD display, the display should be displaying:

System Ready
Select Mode:

Alternating with:

System Ready
00:00 AM (current clock time)

NOTE: Upon initial power-up the purge display may read **BATTERY FAULT PRESS RESET KEY**. Simply press the **RESET** keypad switch to reset the purge unit and begin the **QUICK START** program. (See "QUICK START" starting on page 24.)

7. Preliminary Checkout is complete.

NOTE: Check Constant Pressure Expansion Valve to confirm evaporator Temperature is -5 degrees in order to obtain the most efficient emission level

SYSTEM COMPONENTS

Figure 2. - Major Components

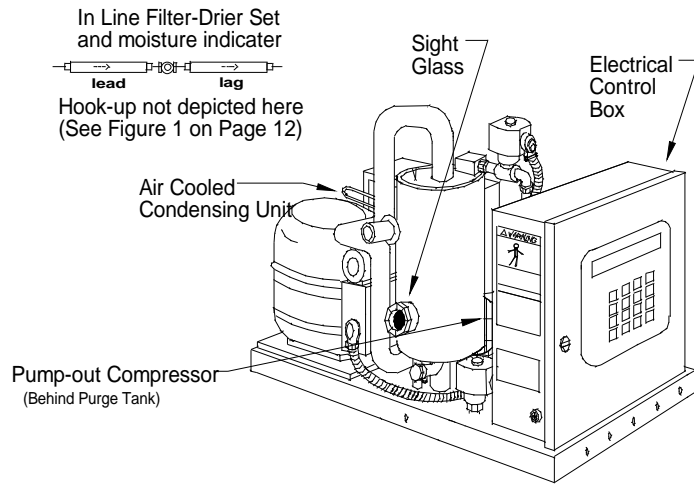

Purge operation is controlled via the 16 keypad switches and display located on the front of the unit control box (see figure 3 and 4 below).

Figure 3. - Electrical Control Box Exterior (Control Panel)

(See Figure 7 on page 30 for larger view of keypad)

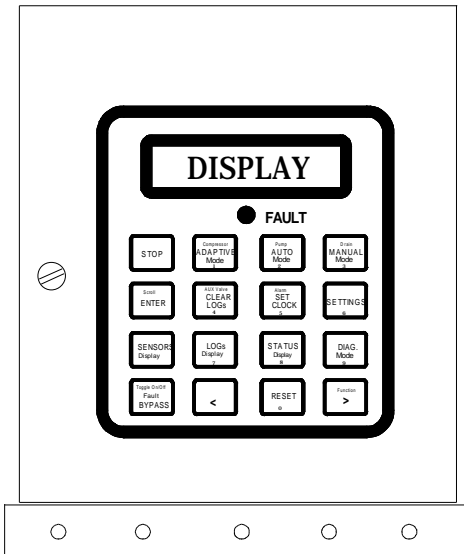

- Dip Switch (S1) ⤵
- Fault indication ⚡ light
- Control Transformer (T1) ⤵
- Remote alarm Relay (RY7) ⤵
- 1 Amp Fuse (F1) ⤵
- Terminal strip (TB1) ⤵

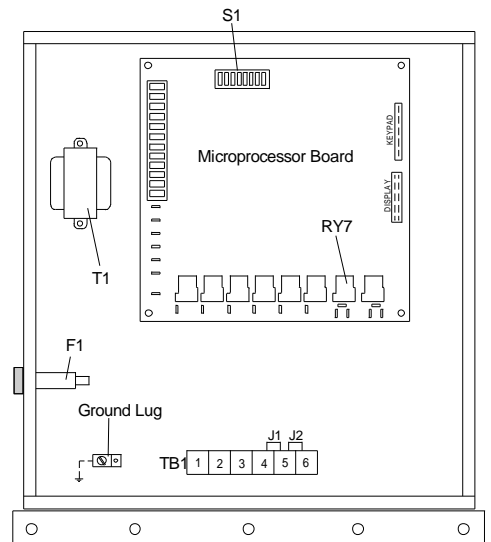

Figure 4. - Electrical Control Box Interior

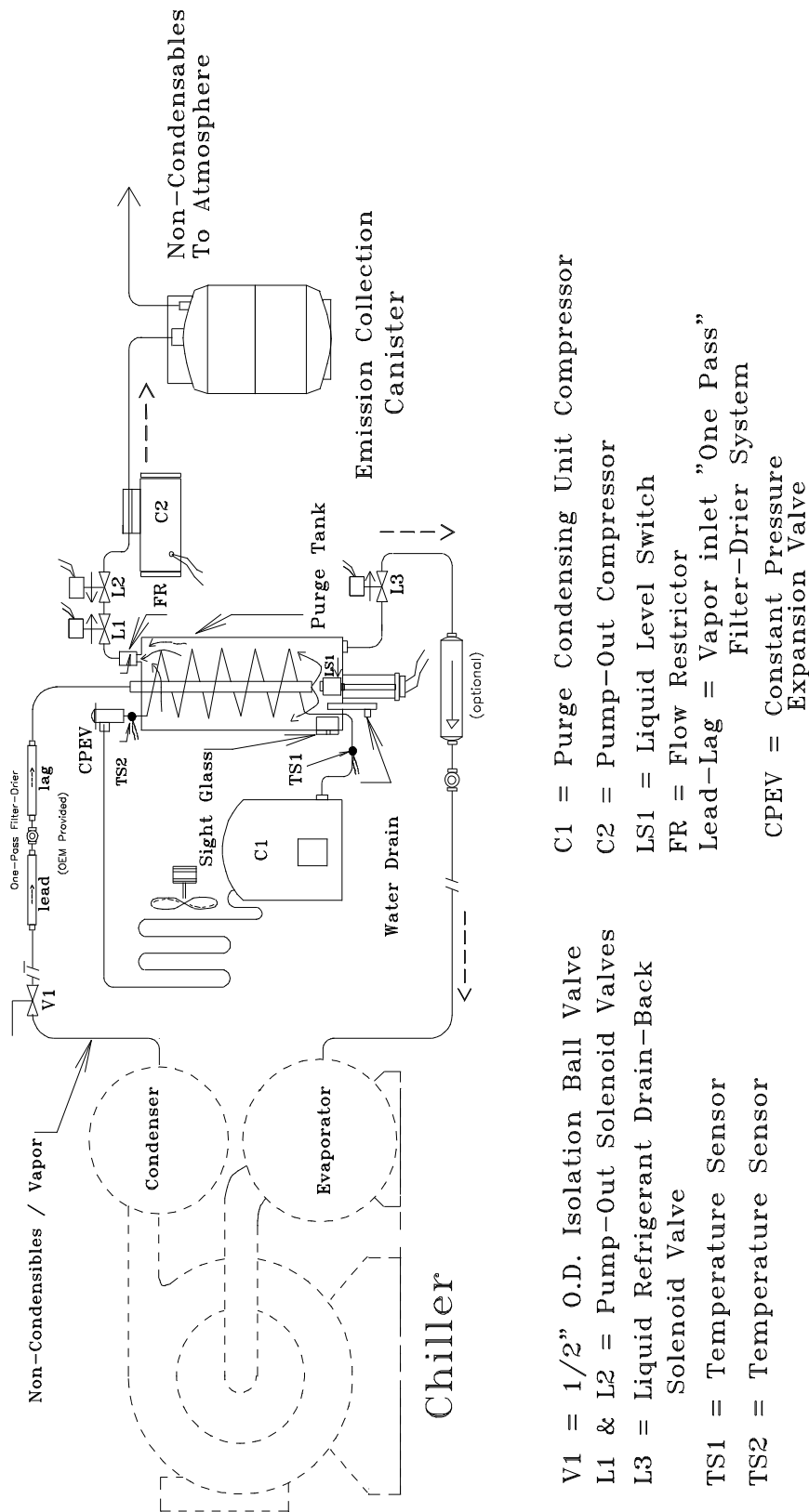

Figure 5. - Flow Schematic and component location
High Efficiency Purge with optional Emission Collection Canister
 (Together, system expels .0049 lbs CFC's or less per lb of air removed)

Purge Tank

The purge tank consists of a refrigerated cooling coil, liquid level switch, liquid level sight glass, water bleed-off valve, and a non-condensables exhaust port. The non-condensables are removed from the purge tank via pumpout solenoid valves L1, L2 and the pumpout compressor. The condensed refrigerant accumulates in the bottom of the purge tank (see Figure 5 on page 18).

Purge and Refrigerant Drain Back Function

Purge activity is continuous while the purge condensing unit is operating. The purge condensing unit provides the cooling source to condense the refrigerant vapor as it enters the purge tank. Accumulation of non-condensables in the purge tank is dependent upon the presence or absence of air in the chiller condenser. If there is no air in the chiller condenser, non-condensables will not accumulate in the purge tank. All condensed refrigerant falls to the bottom of the purge tank where a level of liquid refrigerant is maintained during purge operation. When the purge condensing unit is operating, liquid is visible in the purge tank sight glass. The liquid refrigerant level is controlled by liquid level switch LS1 and liquid return solenoid valve L3 (see Figure 5 on page 18).

Pumpout System

The pumpout system consists of a 1/20 H.P. diaphragm pumpout compressor, two pumpout solenoid valves and a flow restrictor device. When sufficient air has accumulated in the purge tank the purge control energizes and opens the pumpout solenoid valves and starts the pumpout compressor. Air is slowly pumped from the purge tank through the flow restrictor and discharged to an emission collection canister, vent line, or the atmosphere. Removing the air slowly via the restrictor device improves the efficiency of the purge cycle.

The standard pumpout compressor is compatible with both CFC-11, R-113, and HCFC-123.

Filter Driers (and Moisture Monitoring)

Vapor Inlet Filter-Driers

Two (2) Streamline™ one pass filter-driers and moisture indicator are provided with the purge to be **INSTALLED IN THE VAPOR INLET LINE BETWEEN THE CHILLER AND THE PURGE** unit to prevent buildup of acid and particulates in the purge tank (see Figure 1 on page 12).

The filter-driers are capable of adsorbing the moisture of normal humid-air infiltration for a period of up to one year, assuming a "tight" machine, free of water side leaks.

Security-Lock

The purge unit is equipped with a simple security lock system that prevents unauthorized personnel from tampering with certain functions. The purge unit comes from the factory with the security lock enabled (see Dip switch S1 settings starting on page 28).

One example of why the operator may wish to use the “Security Lock” function is that the purge unit in the ADAPTIVE mode acquires a certain amount of historical data in its LOGs which it then uses to determine when and how often the purge needs to run to purge non-condensables from the system efficiently. If an unauthorized person were to inadvertently clear the LOGs the purge unit would then have to run many days to re-acquire historical data. When the “Security Lock” is activated unauthorized entry cannot be made.

Optional Accessories

The purge unit can be equipped with three optional accessories.

1. Emission Collection Canister saturation alarm (option)

If the electronic refrigerant emission monitor for the ZERO EMISSION CANISTER accessory is desired to be incorporated into the purge units control it will indicate when the emission collection canister becomes saturated with refrigerant. For more information contact Equipment Servicing.

2. Chiller mounted condenser temperature sensor TS3 (option)

Optional chiller mounted temperature sensor TS3 is used with “Free-Cooling” or ice storage chillers. It is used to prevent inadvertent refrigerant pumpout by the purge unit when chiller condensing saturation temperature drops “too low”. For more information contact Equipment Servicing.

3. Chiller evaporator pressure Pre-Alarm PS1 (option)

The chiller evaporator pressure Pre-Alarm (PS1) continuously monitors pressure status in the chiller’s evaporator and provides an alarm when the pressure exceeds a pre-determined level. The Pre-Alarm feature maintains a record of the daily peak pressure events and time of day event occurred. For more information contact Equipment Servicing.

System Components

This section identifies the purge system components (see Figures 2, 3, 4, 5, & 6, on pages 17, 18, & 19).

Purge Control Panel

All Purge unit functions are controlled via a multi-function 16-keypad switch and a LCD display located on the front of the unit’s electrical control box. (See information starting on page 30 for further information on the functioning of the various keypad switches.)

Microprocessor Circuit Board

The microprocessor circuit board contains the central processing unit that monitors the various sensor inputs and controls the appropriate outputs such as the relays to activate the various purge functions. (see Figure 4 on page 17)

Compressor unit (C1)

Air cooled condensing unit compressor.

Pumpout Compressor (C2)

Vacuum pump C2 (see Figure 5 on page 18 for location) is used to purge non-condensables from the purge tank during the pumpout cycle.

Temperature Sensor (TS1)

Temperature Sensor TS1 initiates and terminates the non-condensables pumpout cycle (see "Operating Cycle" on page 19).

Temperature Sensor (TS2)

Temperature Sensor TS2 (see Figure 5 on page 18 for location), monitors the purge tank evaporating temperature.

Pumpout Solenoid Valves (L1 & L2)

Pumpout solenoid valve L1 and L2 (see Figure 5 on page 18 for location), are used to control purge exhaust from the purge tank. Operation of L1 and L2 is controlled by Temperature Sensor TS1 via the microprocessor control. Two pumpout solenoid valves are provided since their function in the system is critical.

Drain solenoid (L3)

Drain solenoid valve L3 (see Figure 5 on page 18 for location), is used to control the draining of liquid refrigerant from the purge tank.

Liquid Level Switch (LS1) - (see Figure 5 on page 18 for location).

Liquid level switch LS1 controls the "Upper" liquid refrigerant level in the purge tank. On liquid level rise to the top of the purge tank sight glass LS1 triggers a drain back cycle.

Remote “Purge Fault” Alarm Relay (RY7)

Remote purge fault alarm relay RY7 is used to enunciate a purge fault alarm at a location remote from the purge unit. (see Figure 4 on page 17).

Auxiliary Relay (RY8)

Auxiliary relay RY8 is used when Pre-Alarm option is installed for interlocking peripheral equipment.

Terminal Block (TB1)

Terminal block TB1 is a terminal strip used for field wiring to the purge unit (see Figure 4 on page 17).

Control Transformer (T1)

Transformer T1 is a 12 volt power transformer used to power the microprocessor circuit board (see Figure 4 on page 17).

Constant pressure expansion valve

The function of the constant pressure expansion valve is to regulate and maintain constant evaporating temperature within the purge tank cooling coil under varying load conditions.

QUICK START - OPERATION

NOTE: *If your chiller has been down for repair or has a lot of air in it you may wish to read the service tips starting on page 58 before commencing purge operation.*

Quick Start Introduction

This procedure can only be used if you have properly installed the purge unit and have completed the **PRELIMINARY CHECK OUT AND POWER UP** starting on page 15. The Quick Start instructions are designed to allow the purge operator to get the purge unit operational in as little time as possible. The Quick Start instructions utilize the factory preset default operating parameters shown at the end of the quick start instructions.

NOTE: *If you do not feel comfortable using the Quick Start, skip this section and familiarize yourself with the rest of the manual, then return to this section.*

The LCD display should read:

System Ready
Select Mode

alternating with:

System Ready
00:00 AM (clock display)

NOTE: *Upon initial power-up purge display may read **BATTERY FAULT PRESS RESET KEY**. Press **RESET** keypad switch to reset unit and begin **QUICK START** program.*

1. Press “SET CLOCK” Keypad Switch

Display changes to:

Set CLK 00:00 AM
use < >, 0 - 9

The display reads “00:00” which stands for Hours:Minutes. The underline is the cursor, to set the clock, use the cursor movement (“<” and “>”) keypad switches to move the cursor beneath the appropriate position you wish to change. To change the setting use the **numbered** keypad switches. To change between AM and PM move cursor beneath A or P and press any numbered keypad switch. Once the correct time has been set, you must PRESS the “ENTER” keypad switch TO ENTER NEW SETTING.

Display changes to:

System ready
Select Mode

alternating with:

System Ready

EXAMPLE:

07:13 AM (time just set)

2. Select Desired Operating Mode

The purge unit has three (3) operational modes. Select desired mode by pressing one of the following keypad switches (MANUAL, AUTO, or ADAPTIVE).

In the "**MANUAL**" mode, purge operation is continuous, whether chiller is on or off. The "MANUAL" mode is recommended only for service procedures.

In the "**AUTO**" mode purge operation interlocks with a chiller-generated "cooling/run" signal which provides a run signal to the purge unit's microprocessor control. Operation In the "AUTO" mode is identical to the "ADAPTIVE" mode except operation occurs only while the chiller is running.

In the "**ADAPTIVE**" mode, the purge system operates in a "self-learning" and "self-adjusting" duty cycle mode, based upon previous non-condensable pumpout history. Purge operation is independent of the operational status of the chiller, and will Duty Cycle (start and stop purging activity as needed) whether the chiller is running or not.

"AUTO" MODE IS THE RECOMMENDED NORMAL OPERATING MODE

Security-Lock

The purge unit is equipped with a simple security lock system that prevents unauthorized personnel from tampering with certain functions. The purge unit comes from the factory with the security lock enabled (see Dip switch S1 settings starting on page 28).

NOTE: *SYSTEM IS NOW OPERATIONAL, if you desire any other activity or understanding of the many capabilities such as diagnostics, sensor readings and interpretation of accumulated data, you must familiarize yourself with the rest of this manual. Purge operation will now be automatic. If you desire to Change one or more of the pre-set factory default settings see Setting Operational Parameters on page 26.*

NOTE: *The purge's microprocessor has been pre-programmed with certain PRESET DEFAULTS for each operational parameter setting. The purge will automatically default to those factory preset operating parameters unless changed by the operator. If you are relying upon Quick Start, the following pre-set parameters will apply.*

"PURGE FAULT" - *Preset default 30 minutes (If non-condensable pumpout activity in a 24 hour period exceeds 30 minutes the purge will shut down)*

"FAULT Bypass" - *Preset default 4 hours, FAULT BYPASS overrides "PURGE FAULT" setting for the amount of time set in the FAULT Bypass setting (active only when the BYPASS keypad switch is pressed) For more information, see SETTING OPERATIONAL PARAMETERS on page 26.*

"DRAIN CYCLE" - *Preset default 10 seconds (this time delay sets the make-break hysteresis of liquid level switch LS1).*

QUICK START - COMPLETED

Setting Operational Parameters

To change the purge unit's operational parameters, temporarily switch Dip switch S1-position 4 to the "ON" position (this disables the Security Lock feature -- see Figure 4 on page 17 for Dip switch S1 location). **Once operational parameters are set, switch S1-position 4 back to the "OFF" position.** (This re-enables the Security Lock feature.)

Purge Fault setting

Switch Dip Switch S1-position 4 to the "ON" position.

To set the Purge Fault time press the "SETTINGS" keypad switch and scroll the display using the SCROLL key until the display reads:

Enter Max PURGE
FAULT Min. : 030
(maximum setting 240 minutes)
(minimum setting 1 minute)
(Default Setting 30 minutes)

CAUTION: Always set Purge Fault time as low as possible to limit refrigerant pump-out in the event of a malfunction.

Use the cursor movement keypad switches "<" and ">" to move the cursor beneath the position you want to change. Use the numbered keypad switches to enter the desired value, then press the ENTER key. To change another operational parameter SCROLL to the appropriate display. To EXIT the SETTINGS mode press the STOP key. **Turn Dip switch S1-position 4 to the "OFF" position.** Now select one of the three operating modes.

NOTE: When an entered value either exceeds the maximum allowable parameter, or is lower than the minimum allowable parameter for any setting an "Error Value" message will be displayed. The purge unit's microprocessor will then override the errant value and automatically assign the appropriate default value.

Fault BYPASS setting

Switch Dip Switch S1-position 4 to the "ON" position.

To set the Fault Bypassed time press the "SETTINGS" keypad switch and scroll the display using the SCROLL key until the display reads:

Enter FLT Bypass
Time HRS : 004
(maximum setting 72 hours)
(minimum setting 1 hour)
(Default Setting 4 hours)

Use the cursor movement keypad switches “<” and “>” to move the cursor beneath the position you want to change. Use the numbered keypad switches to enter the desired value, then press the ENTER key. To change another operational parameter SCROLL to the appropriate display. To EXIT the SETTINGS mode press the STOP key. **Turn Dip switch S1-position 4 to the “OFF” position.** Now select one of the three operating modes.

NOTE: When an entered value either exceeds the maximum allowable parameter, or is lower than the minimum allowable parameter for any setting an “Error Value” message will be displayed. The purge unit’s microprocessor will then override the errant value and automatically assign the appropriate default value.

To activate the Fault Bypass mode while in one of the three operating modes press the “Fault BYPASS” keypad switch. The Fault “BYPASS” mode can be exited at any time by again pressing the Fault “BYPASS” Switch.

Drain Cycle setting (sets LS1 liquid level switch make/break hysteresis)

Switch Dip Switch S1-position 4 to the “ON” position.

Verify drain-back cycle for proper operation. With the purge unit operating, verify the purge tank for proper condensing activity by observing the purge tank liquid level sight glass. Liquid should accumulate until the liquid level reaches the top of the purge tank sight glass. At this point, liquid level switch LS1 contacts should close and energize drain-back solenoid valve L3 allowing refrigerant to drain back to the chiller. The liquid level should drop until it reaches the bottom of the sight glass, at which time the microprocessor should de-energize drain solenoid valve L3.

To set the Drain Cycle time press the “SETTINGS” keypad switch and scroll the display using the SCROLL key until the display reads:

Display changes to: **Enter DRAIN cyc.**
 Time Sec. : 010
 (maximum setting 20 seconds)
 (minimum setting 1 second)
 (Default Setting 10 seconds)

Use the cursor movement keypad switches “<” and “>” to move the cursor beneath the position you want to change. Use the numbered keypad switches to enter the desired value, then press the ENTER key. To change another operational parameter SCROLL to the appropriate display. To EXIT the SETTINGS mode press the STOP key. **Turn Dip switch S1-position 4 to the “OFF” position.** Now select one of the three operating modes.

NOTE: When an entered value either exceeds the maximum allowable parameter, or is lower than the minimum allowable parameter for any setting an “Error Value” message will be displayed. The purge unit’s microprocessor will then override the errant value and automatically assign the appropriate default value.

Dip Switch S1 Settings

(Dip Switch S1 only needs to be set if any of the optional sensors have been installed, or when setting operational parameters (see Figure 4 page 17 for Dip switch location).

NOTE: *All dip switches must be set to the “off” “ position unless one or more of the following options are installed.*

Dip switch S1 Security Lock

Dip switch S1 - position 4 “OFF” activates SECURITY LOCK. The SECURITY LOCK prevents unauthorized access to the purge unit’s operational parameters by locking out the following keypad switches: CLEAR LOGs and SETTINGS.

Dip switch S1 Canister Alarm

Dip switch S1 - position 6 “ON” activates the emission collection canister saturation alarm. (when option is Installed)

Dip switch S1 Canister Alarm (Purge Lock-Out Option)

Dip switch S1 -position 3 “ON” activates the “Canister is Full Alarm” (when the emission collection canister is installed) **When using this setting purge operation will cease when Canister Full alarm occurs.**

Dip switch S1 Evaporator Pressure Pre-Alarm

Dip switch S1- position 7 “ON” activates the chiller Evaporation Pressure Pre-Alarm Optional - Sensor PS1 detects when the chiller evaporator pressure has exceeded pre-set maximum limit. (when Installed)

Dip switch S1 Condensing Temperature Option

Dip switch S1 - position 8 “ON” activates the chiller Condensing Temperature Option - Sensor TS3 monitors chiller condensing temperature. (when Installed)

Microprocessor Overview

Introduction

The purge unit controller utilizes a Microprocessor to control all aspects of purge operation including self diagnostics. It also tracks, measures, stores and displays all operational data needed to manage chiller noncondensables. The following is an overview of the microprocessors features and functions.

Safety Features

The Microprocessor Control provides a full array of safety features that will terminate purge operation when an abnormal condition develops in any one of the following areas:

Maximum Allowable Pumpout Time Exceeded (PURGE FAULT)

Purge operation is terminated and a latching "Purge Fault" diagnostic occurs when the pre-set maximum allowable purge pumpout time is exceeded during any 24-hour "sliding window" period.

Drain Operation (DRAIN FAULT)

Purge operation will terminate and a latching "Drain Fault" diagnostic occurs when a drain malfunction is detected.

Sensor Operation (SENSOR ERROR)

Purge operation will terminate and a latching "Sensor Error" occurs when a sensor has failed.

Operating Modes (“Manual” - “Auto” & “Adaptive”)

In the "**MANUAL**" mode, purge operation is continuous, whether chiller is on or off. The "MANUAL" condition is recommended only for service procedures. (see MANUAL keypad switch for further information page 31)

In the "**AUTO**" mode purge operation interlocks with a chiller-generated "cooling/run" signal which provides a run signal to the purge unit's microprocessor control. Operation In the "AUTO" mode is identical to the "ADAPTIVE" mode except operation occurs only while the chiller is running (see AUTO keypad switch for further information on Page 32).

The "**ADAPTIVE**" mode activates the purge's "self-learning" Duty Cycle function. In this mode the microprocessor continually monitors and records a history of all non-condensable pumpout activity, and automatically uses that "recorded" information to "Duty Cycle" (start and stop) future purge operation based upon its "learned" purging needs. This minimizes both energy usage and wear on the unit. When in the "Adaptive" mode, the purge system is enabled (enabled does not mean purging) at all times, and is independent of the operational status of the chiller, and will purge "as needed" whether chiller is "ON" or "OFF". (see ADAPTIVE keypad switch for further information page 32)

The microprocessor's "self-learning" function utilizes a "daily" average non-condensables Pumpout Time" (based only on the last 30 day history) to determine the number of "ON" purging cycles required for any given day. The greater the historical average pumpout time, the greater the number of "ON" purging cycles per day required, the less the historical average pumpout time, the less "ON" purging cycles per day required. When the purge is first installed, or anytime after its data base LOGs have been cleared, purge operation begins with 8 "ON" purging cycles per day and adjusts according to the pumpout history. Each "ON" purging cycle is for a minimum of 30 minutes. The purge "learns" by the following process. During the last 15 minutes of an "ON" purging cycle, if any non condensable pumpout activity occurs, the "ON" period is automatically extended 15 minutes. The "ON" purging Cycle period will continue extending itself until all non-condensable pumpout activity has ceased. If the "ON" Cycle continues extending indefinitely, there is probably a problem with either the chiller or the purge system which requires attention.

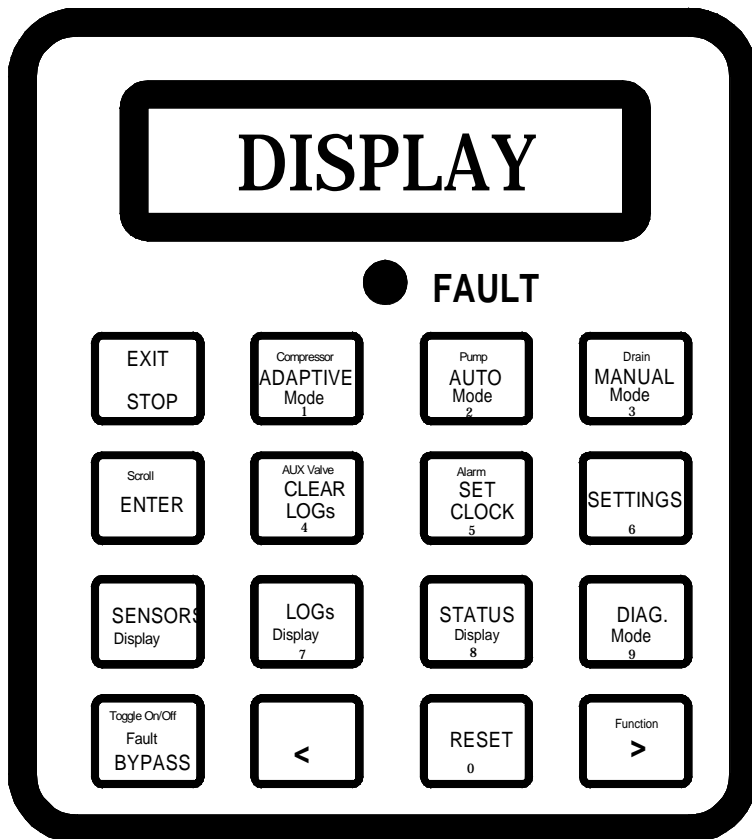

**Figure 7. -
Purge Control
Panel**

LCD Display

The control panel LCD display is back lighted to facilitate viewing in low light ambient conditions. The back light is activated when any keypad switch is pressed. However, if the operator simply wishes to activate the back light the “STATUS” switch is the preferred choice since it has no effect on purge operation. If after 30 minutes of no further keypad activity the back light will automatically go off.

NOTE: *The LCD back light automatically activates during any “FAULT” condition and will remain activated until the “FAULT STATUS” is reset (see page 45 for additional information on fault indications).*

Keypad Switches

All purge unit functions are controlled via a multi-function 16-switch keypad and a LCD display located on the front of the unit’s electrical control box. (See pages 31 through 40 for further information on the functioning of the various keypad switches)

NOTE: *Some keypad switches have multiple functions, the same switch may serve a different purpose depending upon the mode you are in (i.e. the ADAPTIVE mode switch is also a compressor test switch and a number 1 switch).*

“AUTO” Keypad Switch

To enter the "Auto" mode press the "Auto" Switch. The display will read “On Auto” mode indicating the purge is operating in the "Auto" mode. The purge will remain in the “Auto” mode until another keypad switch is pressed, such as STOP, or SET CLOCK or when a different mode is selected. Display changes to:

ON Auto Hh: Mm left 00:15 (Example)	Off Auto Hh: Mm left 02:35 (Example)	Off Auto Chiller is off
Indicates the purge is active and the amount of time (hours and minutes) remaining in the “ON” period (see page 29 for further information).	Indicates the amount of time (hours and minutes) remaining in the “OFF” period (see page 29 for further information).	Indicates all purging activity has ceased while the chiller is off (see page 29 for further information).

NOTE: *While in the “Auto” mode the display may alternate between one or more displays. The display will usually be self explanatory.*

“ADAPTIVE” Keypad Switch (for additional information see “Operating Modes” page 29)

To enable the "Adaptive" mode press the "Adaptive" Switch. The display will read “On Adaptive” indicating the purge is operating in the "Adaptive" mode. The purge will remain in the Adaptive" mode until another keypad switch is pressed, such as STOP, or SET CLOCK or when a different mode is selected. Display changes to:

ON Adaptive Hh: Mm left 00:15 (Example)	Off Adaptive Hh: Mm left 02:35 (Example)	Adapt, 3hr test Hh: Mm left 02:43 (Example)
Indicates the purge is active and the amount of time (hours and minutes) remaining in the “ON” period (see page 29 for further information).	Indicates the amount of time (hours and minutes) remaining in the “OFF” period (see page 29 for further information).	Indicates the purge is running in the three (3) hour test after a chiller shut down to determine if there are any residual non-condensables remaining in the chiller (see page 42 pumpout during first 3 hours after last chiller shutdown for further information).

NOTE: *While in the “Adaptive” mode the display may alternate between one or more displays. The display will usually be self explanatory.*

“SENSORS” Keypad Switch

NOTE: *Can be used in conjunction with the DIAG. Switch for system diagnosis.*

Used to view the following sensory data:

- 1) Purge condensing unit compressor suction temperature (Superheat).

Displayed: **Superheat °F**

- 2) Purge tank evaporating temperature.

Displayed: **Evaporator °F**
Normal Range -5° to +10° F
0° F Typical

- 3) Purge liquid level status.

Displayed: **Liq level High**
or
Liq level Low

“SETTINGS” Keypad Switch

The SETTINGS keypad switch is used to view or set the following purge operating parameters: (see “Setting Operation Parameters” on page 26)

Purge Fault Time
Fault Bypass Time
Drain Cycle Time
Chiller Cond. Temp. lock out set-point (when option installed)
Chiller Evaporator Pre-Alarm set-point (when option installed)

“BYPASS” Keypad Switch

Used to temporarily bypass “Purge Fault” time. “Purge Fault” time is the maximum allowable pumpout time during any 24-hour “Sliding Window” period. Fault “Bypass” is generally used during service procedures or operational checks.

Press Fault “BYPASS” keypad switch to initiate the Fault Bypass mode. The duration of the Fault Bypass TIME PERIOD is determined by the time entered in the SETTINGS operational parameters (1 to 72 hours -- see page 26). **At the conclusion of the “Bypass” time period, the purge will automatically resume normal operation.**

Displayed: **Fault Bypassed**

Time left: 00:00

Exiting Fault “BYPASS” Mode

The Fault “BYPASS” mode can be exited at any time by again pressing the Fault “BYPASS” Switch.

The recommended "FAULT Bypass time" setting is 4 hours.

NOTE: *When in this mode the display will alternate between the “Fault Bypassed” display and the current operating mode. The purge may also alternate between other displays, which will be self explanatory.*

NOTE: *Pumpout time that occurs while in the Fault “Bypass” mode is not added to 30-Day averages, but is added only to cumulative pumpout time. **The last 24 hour pumpout time and display will reset to zero and will remain at zero during the bypass period.***

WARNING: Since the purge unit has NO “Purge Fault” protection when in the “Bypass” TIME PERIOD, the Fault “Bypass” mode should be used sparingly, and only if purge system is in proper working order.

“DIAG.” Keypad Switch

The “DIAG” mode can only be accessed by pressing the “DIAG” keypad switch, then immediately entering access code number “47”.

NOTE: *All purge unit activity ceases when in the Diagnostic mode. This allows the purge operator to perform various “isolated” diagnostic tests. The “SENSORS” keypad switch may also be used while in the diagnostic mode.*

The “DIAG” keypad switch is used to test the Compressor, Pump, Drain, and Remote Alarm circuits and may be used in conjunction with the SENSORS display keypad switch for purge analysis. Any one output or combination of outputs may be selected simultaneously.

Displayed: **Diagnostics Mode**
OUTPUTS = One or more of the following:
C for Compressor
P for Pump
D for Drain
A for Alarm
B for Auxiliary Relay (R-113 purge unit only)

Examples:

“Pump” keypad switch (press to activate, press again to deactivate)

Used to activate pumpout circuit which includes:

pumpout compressor C2

pumpout solenoid valves L1 and L2

Pumpout Relay RY2, with its associated LED indicator

Displayed: **Diagnostics Mode**
OUTPUTS = P

“Drain” keypad switch (press to activate, press again to deactivate)

Used to activate drain circuit which includes:

drain solenoid valve L3

Drain Relay RY3, with its associated LED

Displayed: **Diagnostics Mode**
OUTPUTS = D

“Compressor” keypad switch (press to activate, press again to deactivate)

Used to activate compressor circuit which includes:

compressor C1

Compressor RY1, with its associated LED indicator

Displayed: **Diagnostics Mode**
OUTPUTS = C

“Alarm” keypad switch (press to activate, press again to deactivate)

Used to activate the remote alarm relay RY7:

relay RY7 is activated

Displayed: **Diagnostics Mode**
OUTPUTS = A

“AUX VALVE” keypad switch (Used only with R-113 purge units) (press to activate, press again to deactivate)

Used to activate the pump bypass relay RY4:

relay RY4 is activated

Displayed: **Diagnostics Mode**
OUTPUTS = B

NOTE: *Purge will remain in the Diagnostic mode until the STOP keypad switch is pressed.*

NOTE: *Note: The "SENSORS" keypad switch can be used while in the diagnostic mode.*

"LOGs" Keypad Switch

Log 1 - 30 day "sliding window" average purge pumpout time (chiller OFF)

Displayed: **Pump 30 day Avg.**
Chlrr OFF: 00:00 (hours:minutes)

To view actual pump-out time day-by-day for last 30 days (or for the number of days recorded in the Log up to 30 days), use the "<" or ">" keypad switch to scroll forward and backward one day at a time.

Displayed: **Chlr off Pumpout**
Day 00 H:M 00:00 (hours:minutes)

To return to start of "Log 1" press "LOGs" Keypad switch again.

To advance to next Log press "SCROLL"

To exit "LOGs" display press "STATUS"

Log 2 - 30 day "sliding window" average purge pumpout time (chiller on)

Displayed: **Pump 30 day Avg.**
Chlrr ON: 00:00 (hours:minutes)

To view actual pump-out time day-by-day for last 30 days (or for the number of days recorded in the Log up to 30 days), use the "<" or ">" keypad switch to scroll forward and backward one day at a time.

Displayed: **Chlr on Pumpout**
Day-00 H:M 00:00 (hours:minutes)

To return to start of "Log 2" press "LOGs" Keypad switch again.

To advance to next Log press “SCROLL”

To exit “LOGs” display press “STATUS”

Log 3 - Pumpout time that has occurred during last 24 hour “sliding window” period

Displayed: Last 24 Hours
Pump out : 00:00 (hours:minutes)

To advance to next Log press “SCROLL”

To exit “LOGs” display press “STATUS”

Log 4 - Pumpout time during the 1st three(3) hours following last chiller shutdown

Displayed: 3 Hour Test
Pump out : 00:00 (hours:minutes)

To advance to next Log press “SCROLL”

To exit “LOGs” display press “STATUS”

Log 5 - Average daily chiller RUN time for last 30-day period

Displayed: Chiller Run Hrs.
30day Avg: 0 (hours)

To advance to next Log press “SCROLL”

To exit “LOGs” display press “STATUS”

Log 6 - Total accumulated purge condensing unit “RUN” time since installed

Displayed: Condensing Unit
Run Hrs.: 00000 (hours)

To advance to next Log press “SCROLL”

To exit “LOGs” display press “STATUS”

Log 7 - Total accumulated purge “pumpout” time since installed

Displayed: Cumulative H:M
PumpOut 00000:00 (hours:minutes)

To advance to next Log press “SCROLL”

To exit “LOGs” display press “STATUS”

Log 8 - Average daily pumpout time for last 30 day period

Displayed: 30 Day Pump Out
Avg Mins. : 00:00 (hours:minutes per day)

To view actual pump-out time day-by-day for last 30 days (or for the number of days recorded in the Log up to 30 days), use the “<” or “>” keypad switch to scroll forward and backward one day at a time.

Displayed: total PumpOut
day 00 h:m 00:00 (hours:minutes)

To return to start of “Log 8” press “LOGs” Keypad switch again.

To advance to next Log press “SCROLL”

To exit “LOGs” display press “STATUS”

**Log 9 - Number of Adaptive or Auto run cycles “Chiller ON”
(maximum 8 cycles per day)**

Displayed: Adpt Chiller run
Example: Cycles/day 8 (No. of cycles per day)

To advance to next Log press “SCROLL”

To exit “LOGs” display press “STATUS”

**Log 10 - Number of Adaptive only run cycles “Chiller OFF”
(maximum 8 cycles per day)**

Displayed: Adpt Chiller off
Example: Cycles/day 8 (No. of cycles per day)

To advance to next **Log** press “**SCROLL**”

To exit “**LOGs**” display press “**STATUS**”

Log 11 - Interval Log - Total chiller run time since log last reset.

This log is provided to help the operator track desired service intervals, such as chiller run time since last oil change, or run time hours until next refrigerant analysis, etc..

Displayed: **Interval LOG H:M**
Day 00 00000:00 (hours:minutes)

The “Interval Log” can only be reset by pressing the “RESET” Keypad Switch while viewing the Interval LOGs.

To return to “**Log 1**” press “**SCROLL**”

To exit “**LOGs**” display press “**STATUS**”

“CLEAR LOGs” Keypad Switch

This switch is used to zero out data from certain LOGs. To use the “**CLEAR LOGs**” keypad switch the “Security Lock” must be deactivated (see Dip switch S1 Security Lock page 28).

Displayed: **30 Day history**
will be Deleted

Alternating with

Press RESET to
Clear LOGS

After the **RESET** key has been pressed the display will read:

LOGs are Cleared

NOTE: *The CLEAR LOGs function does not reset the compressor run time or the Cumulative pumpout time since this data has a significant historical value for purge and chiller analysis. Also the interval log will not be cleared (see interval LOGs above).*

To exit “CLEAR LOGs” press “STATUS” switch. **Be sure to enable Security Lock. Switch Dip switch S1-position 4 to the “OFF” position.**

“RESET” Keypad Switch

RESET is used to re-initiate purge operation following a purge fault condition (see FAULT INDICATION page 46). **RESET** is also used to reset the Interval log.

“STATUS” Keypad Switch

Allows operator to display the current purge unit operating mode. The “**STATUS**” keypad switch can also be used as the exit key for LOGs, CLEAR LOGs, and SENSORS display.

“<“or“>“ CURSOR MOVEMENT Keypad Switches

The cursor keypad switches are used to move the cursor left or right when setting certain function parameters such as; “SET CLOCK” and “SETTINGS”. The “<“and “>“ switches are also used to scroll through the HISTORICAL LOGs.

Informational Displays

The informational displays are viewed by pressing these keypad switches:

STATUS Display
LOGs Display
SENSOR Display

Certain other miscellaneous displays will appear (such as fault warning, drain delays etc.) when and if they occur. See pages 44, 45 and 46 for further information.

STATUS Display

The “**STATUS**” keypad switch allows the operator to view current purge unit operational status. After viewing alternate displays, such as LOGs and SENSORS, the STATUS keypad is used to return to the current operating mode display. The purge unit will automatically return to the system status display when there has been no keypad activity for a period of 5 minutes, except when in the diagnostic mode.

When the Purge is not in one of the three operational modes the display will read.

Displayed: **System Ready**
 Select Mode

Alternating with

System is Ready
 00:00 (current time)

When the Purge is in one of the three operational modes the current **STATUS** display will indicate current operational status by displaying one of the following (with the appropriate time information see example below).

Displayed: On Manual
or: On Auto
or: On Adaptive
or: Off Auto
or: Off Adaptive

Example: On Adaptive
HH:MM Left 00:23 (time left in
“ON” purging cycle)

LOGs Display

Use “**SCROLL**” keypad switch to scroll through **LOGs** display sequence.

Log 1 - Purge 30-day average pumpout time while chiller is off (Hrs & Min.)

Because there is a separate tracking of the purge pumpout time during the first three (3) hours after a chiller shutdown (see “Pumpout Time During First Three Hours After Last Chiller Shutdown” on Page 42), this 30-day average period starts 3 hours after chiller has shut down. It indicates the average daily purge pumpout time based on a thirty (30) day sliding window while the chiller is off. Service pumpouts that occurred while operating in “Fault Bypass” mode are not included in this log.

Log 2 - Purge 30-day average pumpout time while chiller is on (Hrs & Min.)

Indicates the average daily pumpout time based on a thirty (30) day sliding window while the chiller is running.

Log 3 - Purge Pumpout for Last 24 Hours (Hrs & Min.)

Indicates pumpout time that has occurred during the last 24 hours.

NOTE: *Pumpout time is added to and adjusted upward in this log in one (1) minute increments as it is occurring, however this is a sliding window log that may adjust itself downward hourly. The operator needs to be aware that time subtracted from the display when updating is representative of pumpout activity that occurred during the one-hour period, 24 hours pervious.*

Log 4 - Pumpout time first 3 hours after last chiller shutdown (Hrs & Min.)

Indicates pumpout activity during the first three hour period after the last chiller shutdown.

Sometimes not all of the air that has leaked into the chiller can be completely purged while the chiller is operating. The only way to purge this air is to operate the purge while the chiller is off. This is an automatic function of the purge when operating in the “ADAPTIVE” mode. Any time the chiller stops, the purge automatically starts and runs for three hours. (The actual period may be longer than three hours, because of the drain back equalization periods (see page 44), but the purge time will be three hours). Typically this is sufficient time to remove any residual air left over from the previous chiller run cycle. It is important to be able to distinguish this purge activity from other purge activity resulting from air infiltration occurring as a result of the chiller being off. This additional information will aid the chiller operator in diagnosing leaks.

NOTE: *When in the “Adaptive” mode, anytime the chiller shuts down the purge automatically starts and runs for 3 hours. When the purge is operating in the 3-hour period following chiller shutdown, it may go into several drain back equalization cycles. This is normal. The purge is programmed to anticipate drainage imbalance conditions due to purge tank pressure gradients that can develop when the chiller is not running (see Drain Back Equalization Cycle on page 44 for further explanation). Even though there may be drainage delays during this period, the total purge run time will be three hours. Therefore, due to the drain back equalization cycle you may see purge activity longer than 3 hours after a chiller shuts down.*

Log 5 - Last 30-Day Chiller Run Time (daily average) (in hours)

Indicates daily average chiller run time based on last 30-day sliding window.

Log 6 - Total Purge Condensing Unit Run Time (in hours)

Indicates total purge condensing unit run time from installation to date **(This historical log is not re-settable)**.

Log 7 - Total Cumulative Pumpout Time (in hours and minutes)

Indicates total purge pumpout time from installation to date **(This historical log is not re-settable)**.

Log 8 - 30-Day Average Pumpout Time per day (Hrs & Min.)

Indicates average purge pumpout time per 24 hour period over last 30-days

Log 9 - Number of Adaptive or Auto run cycles “Chiller ON” (maximum 8 cycles per day)

Indicates the number of current minimum “ON” purging cycles the purge will run per day (while the chiller is running) in the “ADAPTIVE” or “AUTO” mode.

NOTE: *In the ADAPTIVE or AUTO mode the number of ON/OFF cycles per day are based upon historical data from a 30 day average (sliding window) of purge operation.*

Log 10 - Number of Adaptive only run cycles “Chiller OFF” (maximum 8 cycles per day)

Indicates the number of current minimum “ON” purging cycles the purge will run per day (while the chiller is off) in the “ADAPTIVE” mode only.

NOTE: *In the ADAPTIVE mode the number of ON/OFF cycles per day are based upon historical data from a 30 day average (sliding window) of purge operation.*

Log 11 - Interval log (in days, hours and minutes)

Allows the purge operator a method of tracking purge operation during certain operator determined service intervals (see interval log at the end of the explanation of LOGs keypad switch on page 39 for more information).

“SENSORS” Display

Displays:

Superheat ° F (purge unit compressor suction temperature)
Evaporator ° F (purge tank Evaporating temperature)

and...

Liq. Level High or LOW (purge tank liquid level status)

(Superheat) Refrigeration Compressor Suction Temperature

Indicates suction line temperature in degrees °F.

(Evaporator) Purge Tank Evaporating Temperature.

Indicates purge tank inlet evaporating temperature in degrees °F.

(Liquid Level Status) Drain Status

Indicates status of liquid refrigerant level in the purge tank.
(see “Drain Back Equalization Cycle” on page 44 for more information on purge tank liquid drain activity)

“MISCELLANEOUS” - Informational Displays

Pump-out Display

When the purge unit is exhausting non-condensables the display will alternate between the current operating mode and the pumpout display.

Displayed: Pump out Active

Example: Duration: 00:00 (minutes & seconds)

DRAIN BACK EQUALIZATION CYCLE

Under certain conditions (such as when the purge is operating while the chiller is OFF), pressure gradient imbalances may developed which can retard liquid drainage from the purge tank. The purpose of a “**DRAIN BACK EQUALIZATION CYCLE**”, is to periodically cycle the purge condensing unit “off” so that pressures can equalize between the chiller and the purge, and thus allow the purge tank to drain. This is a normal operating sequence.

If after two minutes liquid level switch LS1 senses that the condensed refrigerant within the purge tank is not draining properly a Drain Back Equalization Cycle is initiated.

Maximum duration of the **DRAIN BACK EQUALIZATION CYCLE** is 10 minutes. If however, at the end of 10 minutes liquid level Switch (LS1) has not sensed proper drainage, the purge will shut down on **Drain Fault**.

When the purge unit is in a drain cycle the LCD display will alternate between the current operating mode and one of the following drain displays:

Draining liquid
Liq. level HIGH

This indicates the liquid level in the purge tank is above the “Make” point of liquid level switch LS1. Drain solenoid valve L3 should be energized. As soon as the liquid level drops below the “Break” point of liquid level switch LS1 a “Drain Cycle” time delay is initiated which keeps the drain solenoid valve L3 energized for up to twenty seconds (depending on pre -set time, see “Drain Cycle” time page 27).

Displayed: Draining Liquid
Delay....

If however, "Liq. Level HIGH" remains displayed continuously for two (2) minutes the purge will automatically enter a "Drain Back Equalization Cycle" which can last up to 10 minutes.

Displayed: **Drain Equalizing**
Max. Delay : 00:00(min. & sec. to "Drain Fault")

If the liquid level switch LS1 senses proper drainage (LS1 contact reopens) anytime during the 10 minute Drain Back Equalization Cycle the purge unit will automatically resume normal operation. However, if the liquid level is still "HIGH" at the end of ten 10 minute Drain Back Equalization Cycle the purge will shut down on "DRAIN FAULT".

Displayed: **DRAIN FAULT**

If the Drain Back Equalization Cycle terminates in less than two (2) minutes the purge unit will enter a two (2) minute "Compressor Delay" to prevent short cycling the compressor.

Displayed: **Drain Equalizing**
Compressor Delay

NOTE: *If a DRAIN BACK EQUALIZATION CYCLE should occur during certain timed operating functions, (such as an adaptive "ON" cycle) that functions time will automatically be extended in minute equal to the number of lapsed minutes that occurred during the drain back equalization cycle.*

Sensor Error Displays

Indicates a defective sensor, (i.e. sensor shorted or open, or optional pressure transducer defective):

Displayed: **SENSOR ERROR (TS1)**
Superheat... plus temperature in °F (see note)

Displayed: **SENSOR ERROR (TS2)**
Evaporator... plus temperature in °F (see note)

NOTE: *Anytime "SENSOR ERROR" is displayed, purge operation is inhibited.*

Fault Indications

PURGE FAULT

Indicates maximum allowed pumpout time during any 24 sliding window hour period has been exceeded

Displayed: **PURGE FAULT**

When purge pumpout time exceeds pre-set maximum allowed pumpout time, (see SETTINGS operating parameters starting on page 26) the purge will Lock-Out on "PURGE FAULT".

DRAIN FAULT

Indicates the purge is "OFF" in a drain fault condition.

Displayed: **DRAIN FAULT**

Under certain conditions (such as when the purge is operating while the chiller is OFF), pressure gradient imbalances may develop which can retard liquid drainage from the purge tank. A "DRAIN BACK EQUALIZATION CYCLE" periodically cycles the purge condensing unit allowing pressures time to can equalize, and thus allow the purge tank to drain.

If the drain back equalization cycle fails to correct such pressure gradient imbalances, or if there are any other problems affecting proper drainage such as a defective drain solenoid valve, float switch, etc. then a drain fault will occur.

BATTERY FAULT

Indicates purge is "OFF" in a battery fault condition.

Displayed: **BATTERY FAULT**

The Microprocessor Controller incorporates a permanent self-charging battery backup that prevents loss of critical data during power down periods or power failure. The battery back-up will maintain stored data and parameters for approximately 10 days.

When a "BATTERY FAULT" has occurred, all fault parameters settings will revert to their factory default setting (see page 26). All information stored in the operational data LOGs as well as clock time will also be lost. Clock time and fault parameter settings will have to be reset.

MAINTENANCE

This section discusses the Purge system maintenance requirements and procedures, and presents basic purge troubleshooting procedures.

Periodic Maintenance

The following maintenance procedures are required to assure efficient and reliable operation of the Purge.

WARNING Certain servicing procedures expose you to refrigerant. To minimize the possibility of injury, follow the safety procedures on the label and in the material safety data sheet for the refrigerant.

Weekly

Check moisture indicators. If moist refrigerant is indicated, replace the filter-drier. (Refer to moisture monitoring below and "Filter-Drier Replacement" on page 49).

Check purge tank sight glass for free standing water. If there is free standing water present there will be a visible line of separation between the water and the refrigerant. Remove any free standing water from the purge tank (see "Purge Tank Service" beginning on page 49).

Semi-Annually

Clean the air-cooled condenser coils using compressed air or coil cleaner. Clean the coil from the fan-side.

Note: This is extremely important as a dirty coil reduces both purge efficiency and capacity.

Moisture Monitoring

A moisture indicating sight glass is provided between the lead and lag sections of the "Streamline-One-Shot™" filter-drier set installed in the vapor inlet line on all purge units as standard equipment (see Figure 1 on page 12 for location). When optional liquid return line filter-drier is used, a moisture indicating sight glass should be placed downstream for monitoring the moisture content of the chiller's refrigerant.

These moisture indicators should be inspected periodically to verify the condition of the refrigerant. Notice that a moisture indicator's sensitivity changes with temperature changes. When the moisture content of the refrigerant exceeds the normal parts per million ("ppm") levels shown below, the indicator will read "wet". A continuous "wet" reading for more than three (3) days usually means that the filter-drier (or driers) are saturated and need to be replaced.

After replacing filter-driers, you can not rely on a moisture indicator reading to evaluate refrigerant moisture content until the chiller is operating and the purge unit has logged at least 72 hours of "Total Purge Condensing Unit Run Time".

Reading from Moisture Indicator

Ambient Temperature*	Dry	Normal	Wet
75 Degrees	Less than 5 ppm	5-15 ppm	More than 15 ppm
100 Degrees	Less than 10 ppm	10-30 ppm	More than 30 ppm
125 Degrees	Less than 20 ppm	20-50 ppm	More than 50 ppm

*Degrees Fahrenheit.

Table 1 - Determining Refrigerant Moisture Content

If a saturated filter-drier is allowed to remain in the system after the moisture indicator shows "wet", water will accumulate in the purge tank forming a visible layer on top of the liquid refrigerant and will be visible in the purge tank sight glass. Any such "free water" must continually be removed to avoid excessive corrosive conditions in both the purge tank and the chiller. To remove "free water" from the purge tank, refer to "Purge Tank Services - Water Removal" on page 49 in the Maintenance section of this manual.

When the chiller is likely to contain a high level of moisture (e.g., when starting a new chiller; or after chiller repairs), the purge can be temporarily operated with the filter-driers removed to trap accumulated water in the purge tank. To avoid nuisance trips due to the fault mode (see the settings operating parameters on page 26 for explanation). You may wish to operate the purge for 24 to 48 hours in the BYPASS mode (see BYPASS Keypad Switch on page 33). During this "Bypass" period, moisture in the refrigerant will condense and accumulate in the purge tank where it can then be removed (see "Water Removal Procedure" on page 49).

NOTE: Any "free water" collected in the purge tank must be removed as soon as possible.

When it has been determined that all excessive moisture has been removed, the filter-driers can be re-installed. However, care should be taken not to install the filter-drier too soon. Installing the filter-driers too soon will result in premature saturation. (Refer to "Filter-Drier Replacement" on page 49.)

NOTE: Excessive water collection in the purge tank over a long period of time may be an indication of chiller problems.

Under normal conditions the filter-driers should be installed. The filter-driers are capable of adsorbing the moisture of normal humid-air infiltration for a period of up to one year, assuming a "tight" machine, free of water side leaks.

NOTE: Disregard moisture indicator readings if your purge is operating while filter-driers are removed.

Filter-Drier Replacement

Follow step A when replacing inlet line filters and both steps A and B when an optional filter is installed in the liquid return line.

(A) Streamline-One-Shot™ vapor inlet line filter-driers:

1. Turn off the purge by pressing the purge control “STOP” switch.
2. Isolate the purge from the chiller by closing both the vapor isolation ball valve and the liquid return angle valve. Do not rely on the liquid return solenoid valve to isolate the purge.
3. Remove and discard the lead filter-drier section (see Figure 5 on page 18).
4. Remove the lag filter-drier section and re-install in place of discarded lead section.
5. Install a new filter-drier in place of the lag section.
6. Re-open both isolation valves.
7. Restart Purge by selecting either the "AUTO" or “ADAPTIVE” mode.

NOTE: *Two (2) Streamline™ one pass filter-driers MUST be installed in the vapor inlet line between the chiller and the purge unit to prevent buildup of acid and particulates in the unit's purge tank. DO NOT OMIT OR SUBSTITUTE!*

(B) Optional liquid return line filter-drier: (if used)

1. Turn off the purge by pressing the purge control “STOP” switch.
2. Isolate the purge from the chiller by closing both the vapor isolation ball valve and the liquid return angle valve. Do not rely on the liquid return solenoid valve to isolate the purge.
3. Remove the old filter-drier and install the new replacement drier.
4. Re-open both isolation valves.
5. Restart Purge by selecting either the "AUTO" or “ADAPTIVE” mode.

Purge Tank Service

Water Removal

If there is free standing water visible in the purge tank sight glass: Close the liquid return angle valve on chiller evaporator. With the purge condensing unit running, observe the liquid level as it rises in the purge tank sight glass. At the instant when the line of separation between the refrigerant level and the free standing water is at the top of the water bleed-off stand pipe (copper tube as seen in the purge tank sight glass) quickly press the “STOP” keypad switch.

Purge Tank at a Positive Pressure

If the purge tank is at a positive pressure, as indicated by the chiller condenser pressure gauge, the free standing water can now be drained off into a suitably approved container by slowly cracking open the water bleed-off angle valve at the bottom of the purge tank. Observing the liquid level in the purge tank sight glass, allow the free standing water to slowly bleed-off. As soon as all the water has been removed, close the water bleed-off angle valve. Re-open liquid return angle valve on chiller (see Figure 5 on page 18).

Purge Tank at a Negative Pressure

If the purge tank is at a negative pressure, as indicated by the chiller condenser pressure gauge, it will be necessary to slightly pressurize the purge tank.

First, isolate the purge tank by closing the vapor inlet isolation ball valve (V1 in Figure 5 on page 18) and the liquid return angle valve at the chiller evaporator. **Important: do not rely on the liquid return solenoid valve to isolate the purge tank.** This valve utilizes a special seat material which does not seal off bubble tight. When isolating the purge tank always use the chiller angle valve. Next, using the purge tank water drain angle valve, pressurize the purge tank to approximately 2 psig using dry air or nitrogen.

WARNING: When pressurizing the purge tank, be careful not to exceed 15 psig. Pressurizing the tank above 15 psig could result in serious injury or even death.

The free standing water can now be drained off as described above under "**Purge Tank at a Positive Pressure**".

NOTE: *An alternative to pressurizing the purge tank would be to draw a vacuum on a suitably approved container and allow the pressure differential to push the free standing water from the purge tank into the container.*

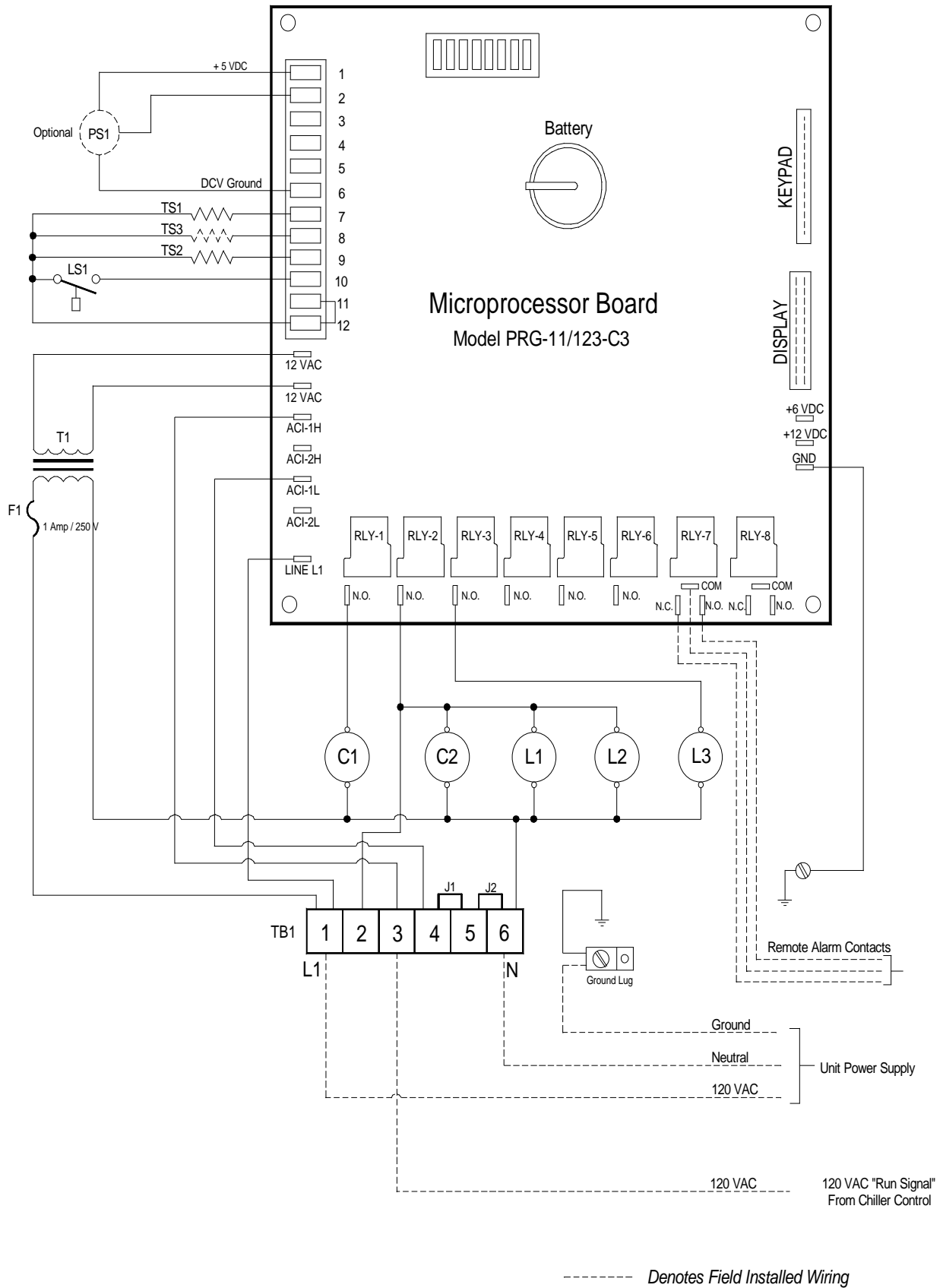

Figure 8. - Electrical Schematic (for York Chillers see Figure 8A).

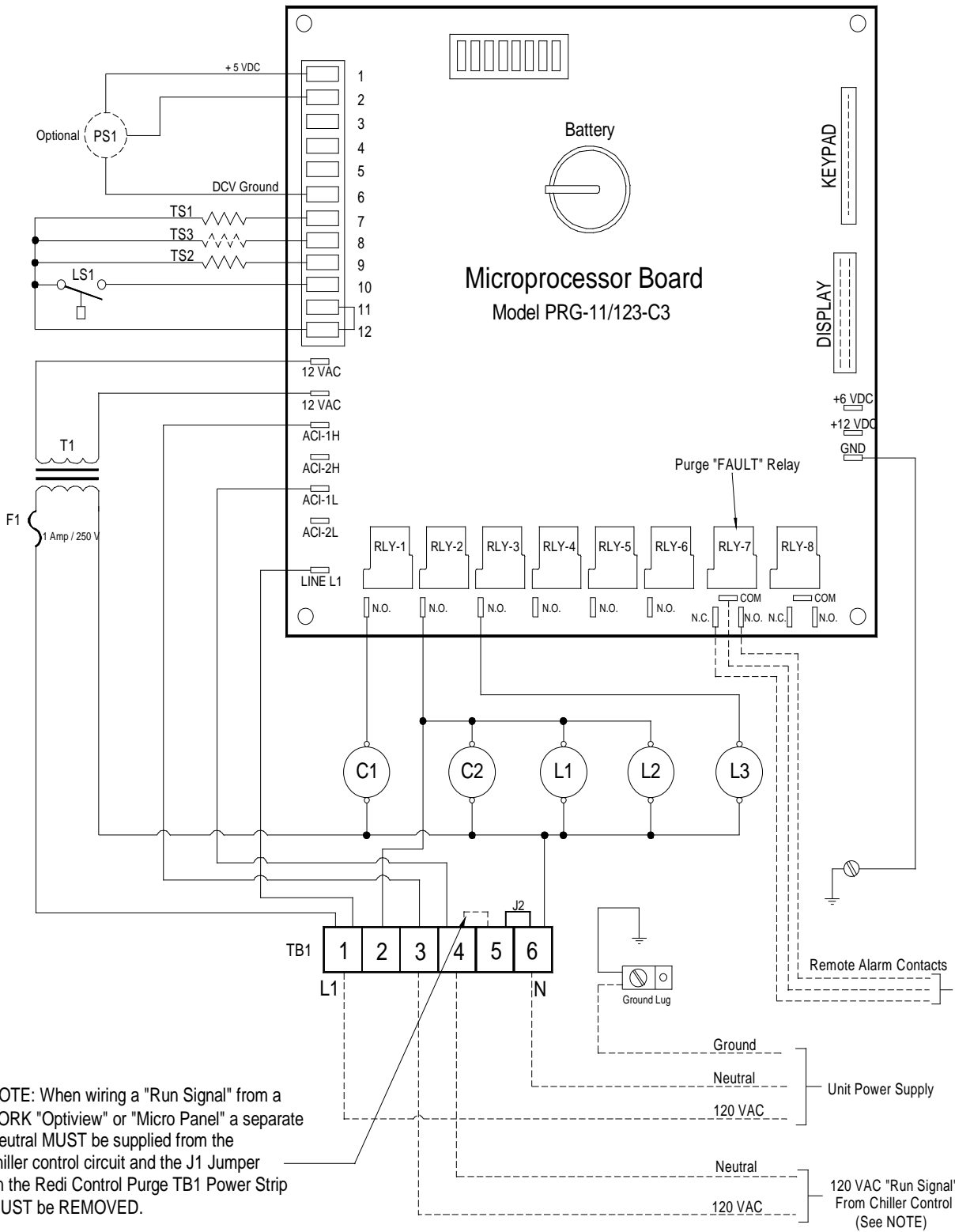

Figure 8A. – Wiring For YORK “Optiview” and “Micro Panel” controls

Trouble Shooting

Should an operational difficulty or malfunction occur, the diagnostic chart and checkout procedures on the following pages should help you to quickly determine the cause and corrective action. The Troubleshooting Chart has a "Symptom" column which describes what the unit is doing; a "Cause" column which identifies possible sources of the problem; and a "Solution" column which describes what must be done to correct the problem. (You can also refer to "Refrigerant System Diagnostic Procedure" on Page 55.)

Troubleshooting Chart

Symptom	Cause	Solution
All circuit board LED's off.	No Power to board F1 Fuse blown	Restore power Replace Fuse
Fuse is good, Verify 12 volts AC @ the two spade terminals labeled 12 VAC and 12 VAC (green wires) on the left side of the circuit board.	If there is no voltage, transformer T1 is defective	Replace Transformer
There is 12 VAC, but the circuit board does not function. Verify that there is +5 volts DC between terminals labeled +5V and GND. Also Verify that there is +12 volts DC between terminals labeled +12V and GND on the circuit board.	If either of these voltages are not present, the Circuit Board is defective	Replace Circuit Board
The Purge is in the "AUTO" mode; but the Purge Unit is "OFF".	Chiller off No "RUN" signal is present at TB1-3	Determine cause and correct
The Purge Display reads: Purge Fault	Excessive air leakage into chiller is causing excessive purging "Purge Fault Time" set too low. Air is leaking into the purge system. Temperature of chiller refrigerant is below 40° F. (Purge can pumpout continuously below 40° F saturation temperature.) Ambient Temperature is too low. Temperature Sensor TS1 is defective One or both Pumpout Solenoid Valves (L1 & L2) fail to open Flow restrictor is blocked and preventing air from being removed. Vapor line Filter-Driers are blocked and restricting flow of vapor from the chiller to the purge unit. Pumpout relay (RY2) is defective	Locate and repair leak Reset Purge fault time according to normal purging requirement Leak-test purge system and repair the leak. Do not operate purge unit at or below 40° F saturated refrigerant temperature. Do not operate purge unit at an ambient temperature of 40° F or less. Replace Sensor Repair or replace defective valves or coils. Replace the flow restrictor. Replace Filter-Driers Replace Circuit board

Troubleshooting Chart (continued)

Symptom	Cause	Solution
The Purge Display reads: Drain Fault	Drain Solenoid Valve (L3) is defective Purge tank level switch (LS1) is defective. Valve in drain-back line is closed Vapor line Filter-Driers are blocked, thus causing excessive pressure drop in the purge tank. Circuit Board "Drain" Relay (RY3) is defective	Repair or replace the valve. Replace the level switch. Open the valve. Replace Filter-Driers. Replace the Circuit Board.
Purge Unit "OFF" in a Fault Condition, but front panel fault light is not ON.	Fault Light is defective.	Replace Keypad.
Purge Fails to pumpout non-condensables when chiller is operating.	Depending upon the type of chiller and operating conditions, air may be logged up in the condenser away from the purge vapor take-off location.	Operate purge in "Adaptive" mode. If it is functioning properly, air in the chiller will be removed.
Purge fails to remove non-condensables, chiller head pressure excessive	Purge may be malfunctioning.	Refer to "Refrigeration System Diagnostic Procedure" on page 55
Purge operation continues after chiller cycles OFF.	Purge set in the "ON" mode. Purge in "Adaptive" Mode	Normal "Chiller off" cycle operation.
No refrigerant level visible in purge tank sight glass.	Purge OFF in a drain back equalization cycle Liquid refrigerant may evaporate back to chiller during prolonged chiller OFF periods, or when the purge is OFF. Liquid Drain Solenoid Valve (L3) failed open. Circuit Board Drain relay (RY3) contacts are welded closed.	Condition normal Liquid should return within 5 minutes of continuous purge operation. Repair or replace the valve. Replace the Circuit Board.
Refrigerant level remains above sight glass and the drain cycle fails to initiate.	Liquid Level Switch (LS1) is defective.	Replace the Liquid Level Switch.
Free standing water is visible in the purge tank sight glass.	Filter-Driers may be saturated with moisture.	Drain water from purge tank and replace Filter-Driers.
Liquid Drain Solenoid Valve (L3) cycles too often	Drain Cycle Time is set for too short of a drain time.	Set Drain Cycle setting to a longer drain time. (see "Setting parameters starting on page 26)
Pumpout Compressor (C2) hot to the touch and will not start	One or both of the pumpout solenoid valves (L1 & L2) failed to open Flow Restrictor (FR) blocked	Repair or replace defective valves or coils. Replace Flow Restrictor

Purge Refrigeration System Diagnostic Procedure

Caution: Do not attempt to measure system discharge or liquid line pressure, it could result in the loss of your refrigerant charge.

Operation of the purge unit's refrigeration system can be diagnosed by taking temperature measurements at various points in the refrigeration circuit (refer to Figure 6 on page 19.). With the purge condensing unit operating, the constant pressure expansion valve (CPEV) will maintain a constant low side pressure in the purge refrigeration system, even with a slight variation in refrigerant charge.

Measuring suction pressure is not recommended, nor is it a good indication of proper refrigerant charge. The only reliable method for determining if the system has a proper charge is by measuring surface temperatures at various points of the refrigerant circuit. Condensing temperature (Point 2 in Figure 6 on page 19.) can be determined by measuring the condenser surface temperature at the 2nd or 3rd condenser tube U-bend from the top on the side opposite the discharge gas inlet.

NOTE: Use an accurate ($\pm 1^\circ F$) temperature meter to take temperature measurements. Attach the temperature sensor tightly to the surface of the tubing at the appropriate point and insulate. When attaching the sensor to points 4 and 5, be extremely careful not to disturb temperature sensors TS1 and TS2.

With the purge condensing unit running, read surface temperatures at points 2 and 3 in Figure 6 on page 19. The difference between these two temperatures is the sub-cooling. With a proper refrigerant charge normal sub-cooling should range between $5^\circ F$ and $15^\circ F$.

A sub cooling less than $5^\circ F$ indicates a refrigerant undercharge.

A sub-cooling greater than $15^\circ F$ indicates a refrigerant overcharge.

NOTE: The purge unit's refrigeration system must contain a proper charge of refrigerant HCFC-134a (0.5 lbs) before any further diagnosis can be made.

Evaporator Pressure CPEV

The function of the constant pressure expansion valve is to regulate and maintain constant evaporating pressure within the purge tank cooling coil under varying load conditions. Proper operation of the expansion valve can be determined by checking the temperature at point 4 in Figure 6 on page 19. An optimum constant operating temperature of $5^\circ F$ should be measured at this point. However, temperature between $0^\circ F$ and $+10^\circ F$ is acceptable.

Temperature Sensor TS1

Sensor TS1 can be checked for proper operation by measuring the surface temperature at point 5 in Figure 6 on page 19. Place display in the "SENSORS" mode and continuously monitor both the temperature at point 5 and "Compressor Suction Temperature." After sufficient air has entered the purge tank, the temperature at point 6 will drop. Also, the

Compressor Suction Temperature (Superheat) being displayed will begin to indicate a lowering of temperature as sensed by Temperature Sensor TS1.

NOTE: *The temperature meter and Temperature Sensor TS1 will not respond to changing temperature at the same rate. Temperature Sensor TS1 will probably lag somewhat behind the meter. However, once the temperature has stabilized, the two readings should equalize within about a minute.*

As the temperature approaches 18°F, the pumpout compressor should energize. Should the pumpout fail to start and the temperature at point 5 remains below 10°F, there is a problem. If the display and meter readings are within $\pm 2^\circ$ F of each other, the problem is elsewhere in the pumpout system. If the readings do not correspond, the problem may be with the Temperature Sensor TS1 (see Table 2 on page 57).

Temperature Sensor TS2

Sensor TS2 can be checked for proper calibration by measuring the surface temperature at point 4 in Figure 6 on page 19. Operate the purge, place the display in the "SENSORS" sequence by pressing the "SENSORS" keypad switch (see Figure 7 on page 30), and monitor "Purge Tank Evaporating Temperature". After approximately 5 minutes of operation, the temperature at point 4 should settle out to approximately 5° F. Both the meter and the display should indicate the same temperature. If they do not correspond within $\pm 2^\circ$ F the Temperature Sensor TS2 may be defective (see Table 2 on page 57).

Optional Temperature Sensor TS3

NOTE: *This test is applicable only when Optional TS3 temperature sensor has been field installed (see Optional Temperature Sensor on page 21 for more information)*

While the purge condensing unit running, detach the temperature sensor TS3 from the chiller. Place TS3 sensor into a small container of water completely submersing the sensor element. Enter the SENSORS mode and scroll to the Cond. Temp. display. By slowly adding ice, gradually lower the water temperature until displayed temperature drops to one (1) degree below the temperature cut out point set in the SETTINGS mode (see Setting Operational Parameters beginning on page 26 for more information). At this point the purge unit should cycle off.

Remove the TS3 sensor from the ice water. When the displayed temperature rises above the parameter setting the purge will go into a 15 minute delay, after the 15 minute delay the purge will return to its previously set operating mode.

NOTE: *If sensor TS3 is installed, the chiller condensing saturation temperature will be displayed in the sensors mode as Evap. Temp. ___ °F.*

Checking for Calibration

Temperature Sensors TS1, TS2 and optional TS3 can be checked for proper calibration by measuring sensor resistance (see Table below).

Temperature		Resistance
(° F)	(° C)	(Ohms)
10	-12.2	14.07K
20	-6.6	10.41K
30	-1.1	7.782K
40	4.4	5.874K
50	10	4.482K
60	15.5	3.458K
70	21.1	2.678K
80	26.6	2.011K
90	32.2	1.653K
100	37.7	1.317K
110	43.3	1.051K
120	48.8	849.3

**Table 2. -
Sensor Temperature
-vs- Resistance**

SERVICE TIPS

Purging after Internal Chiller Repairs or Servicing

The following procedures MUST be performed anytime after the chiller has been opened for repair and exposed to the atmosphere. Whenever air enters the chiller during servicing or repair it will have to be purged before restarting the chiller. **THE PURGE WILL ACCOMPLISH THIS IN TWO PHASES, INITIALLY THE PUMPOUT COMPRESSOR WILL RUN CONTINUOUSLY DUE TO AN EXCESSIVE QUANTITY OF NON-CONDENSABLE AND A SMALL AMOUNT OF REFRIGERANT ENTERING THE PURGE TANK. THIS PHASE OF OPERATION MAY CONTINUE UP TO SEVERAL HOURS, DEPENDING UPON THE AMOUNT OF NON-CONDENSABLE PRESENT.**

NOTE: DURING THIS PHASE THE PUMPOUT FLOW RESTRICTOR MAY BE TEMPORARILY BYPASSED TO MINIMIZE PUMPOUT TIME. (SEE "BYPASSING PUMPOUT FLOW RESTRICTOR" ON PAGE 59).

Once enough non-condensables have been purged, a sufficient amount of refrigerant will again enter the purge tank to cause the temperature Sensor TS1 to begin cycling the pumpout compressor. This is the second phase of the operation and the pumpout compressor may cycle on and off frequently. As the system approaches a more normal condition the pumpout compressor will cycle on and off less frequently.

NOTE: *When operating the purge under these conditions the "Bypass" Mode should be used to avoid tripping out on excessive pumpout "Purge Fault" time. At the end of the Fault "Bypass" time period, as set in the settings operational parameters (on page 26), the purge will automatically resume normal operation.*

NOTE: *Pumpout time accumulated during "Fault Bypass" is not added to the 30-day averaging pumpout log. However, it is added to "Cumulative" pumpout time.*

NOTE: *When large amounts of air or nitrogen are involved, to maximize purge efficiency, it is recommended that warm water (less than 100°F) be circulated through the evaporator tube bundle, or start the chiller as soon as possible. Either procedure will enhance purging efficiency by elevating the refrigerant pressure in the purge tank.*

Bypassing Pumpout Flow Restrictor

THE PUMPOUT FLOW RESTRICTOR MAY BE TEMPORARILY BYPASSED TO ACCELERATE THE REMOVAL OF NON-CONDENSABLE WHEN LARGE AMOUNTS OF NON-CONDENSABLE ARE PRESENT. (TYPICALLY AFTER CHILLER REPAIRS.)

NOTE: *This is a manual procedure that will reduce the efficiency of the purge and should be used only during certain service conditions.*

TO BYPASS THE PUMPOUT FLOW RESTRICTOR:

TEMPORARILY CONNECT A BYPASS HOSE BETWEEN THE BRANCH TEE ON TOP OF THE PURGE TANK AND THE BRANCH TEE AT THE INLET OF THE PUMPOUT COMPRESSOR.

NOTE: *To minimize refrigerant loss; as soon as practical, the bypass hose should be removed and the purge returned to normal operation.*

The following section outlines a few select "Service Tips" for helping the chiller operator get the most from the wealth of purging and operational information stored in the microprocessors data base. While the following discussion is not intended to be all inclusive, it does however serve to illustrate how various data and combinations of data may be used by the operator for managing a chillers refrigerant charge.

Moisture monitor

If there is excessive moisture within the chiller refer to the maintenance section under Moisture Monitoring on page 47).

Air-Leak Rate

The rate at which air may be leaking into the chiller can be determined by monitoring the "Purge pumpout time for the last 24 hours" and the "Purge 30-day average pumpout time."

Example: A gradual but steady increase in purge activity would typically indicate a worsening leak condition such as deteriorating gaskets and/or "O" ring seals.

Example: A sudden marked increase in purge activity (especially as indicated by the "Purge pumpout time in the last 24 hours") might suggest a line such as a gauge line has broken or possibly the rupture disc may have cracked. If the chiller had been serviced or repaired during the previous 24 hour period it might indicate that a leak may have been inadvertently created during servicing.

Locating a leak

Because the purge has the ability to track and record purge activity while the chiller is both operating and off, it is possible to use this information to narrow the location of a leak to a particular area of the machine.

Example: If the majority of pumpout activity occurs while the chiller is off (as indicated by the "Purge 30-day average pumpout time while chiller OFF" log) it can be assumed the air-leak source is on the "High" side of the chiller. It can further be assumed that when the chiller is running this same leak allows refrigerant to leak out.

Example: In rare cases, air that has leaked into the chiller some-times cannot be completely removed while the chiller is running. The only way this air can be removed is to operate the purge after the chiller shuts down. When operated in the "Adaptive" mode, this is an automatic function of the purge and is indicated by the "Pumpout Time during first three hours after shutdown". It is important to distinguish this from other purge activity resulting from air infiltration caused by the chiller being OFF. This additional information will help diagnose a leak source.

Using the "Interval Log"

The purpose of the "Interval Log" is to provide the chiller operator with a method of tracking certain time-based service procedures.

Example: The log may be used to flag a particular scheduled maintenance procedure, such as an oil change or refrigerant analysis.

Data Logging (see Graph/Log Charts for copying on pages 62-66)

The chiller operator may wish to maintain a log on a daily basis, recording at least the following data:

- Purge pumpout time last 24 hours.
- 30-Day Average pumpout time per day.
- Purge 30-day average pumpout time while chiller running.
- Purge 30-day average pumpout time while chiller off.
- Pumpout time during the first 3 hours after chiller shutdown.

A sudden change in the trend of this data, which cannot be accounted for by a relative change in chiller operational patterns, may indicate the need for a system leak check or repair.

Example: A graphical data log is much easier to follow and interpret than a tabular log (see sample chart below).

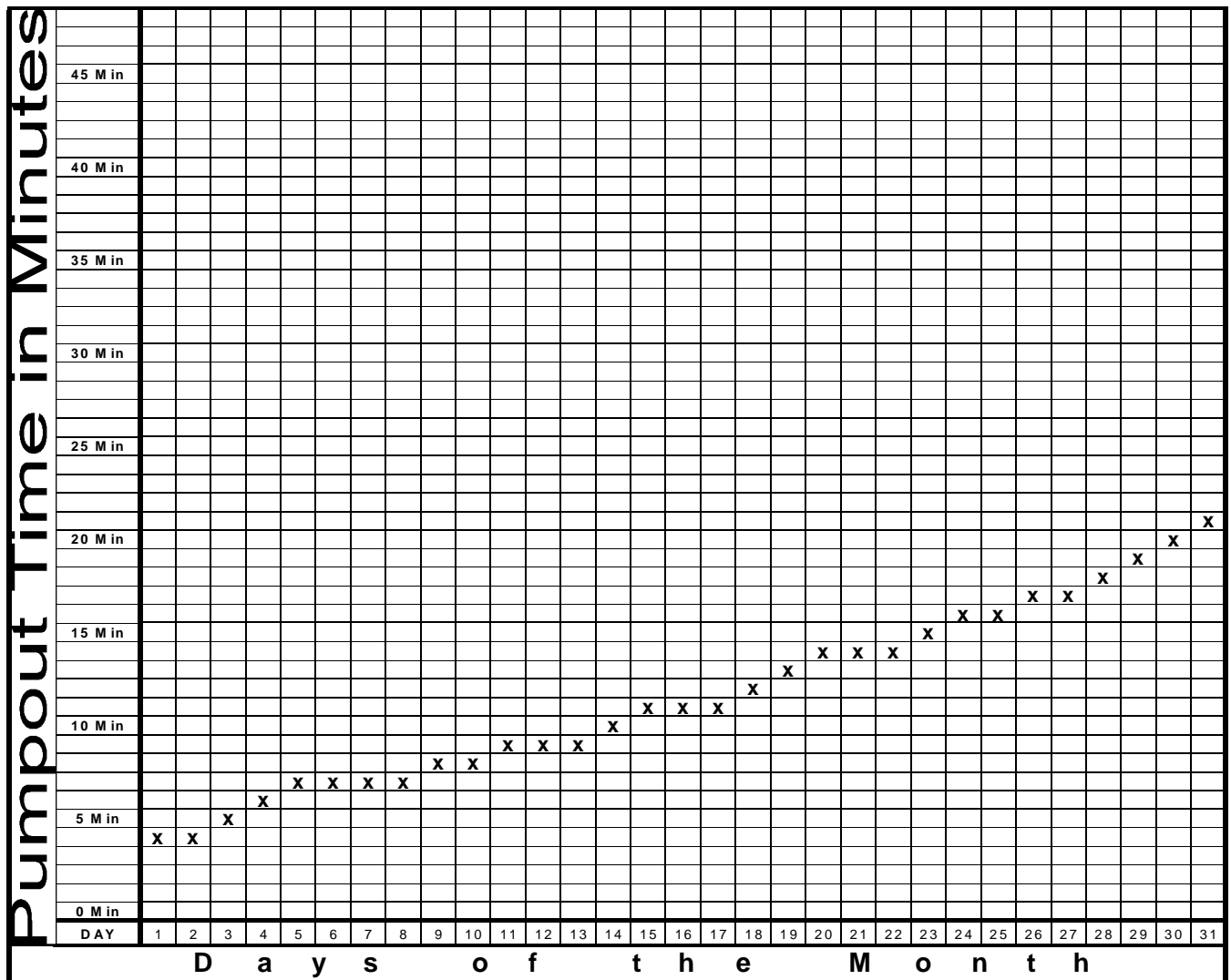

Chiller No. _____ Record for: _____ : _____
 (Month) (Year)

3 Graph & Log - Purge Pumpout Time Last 24 Hours

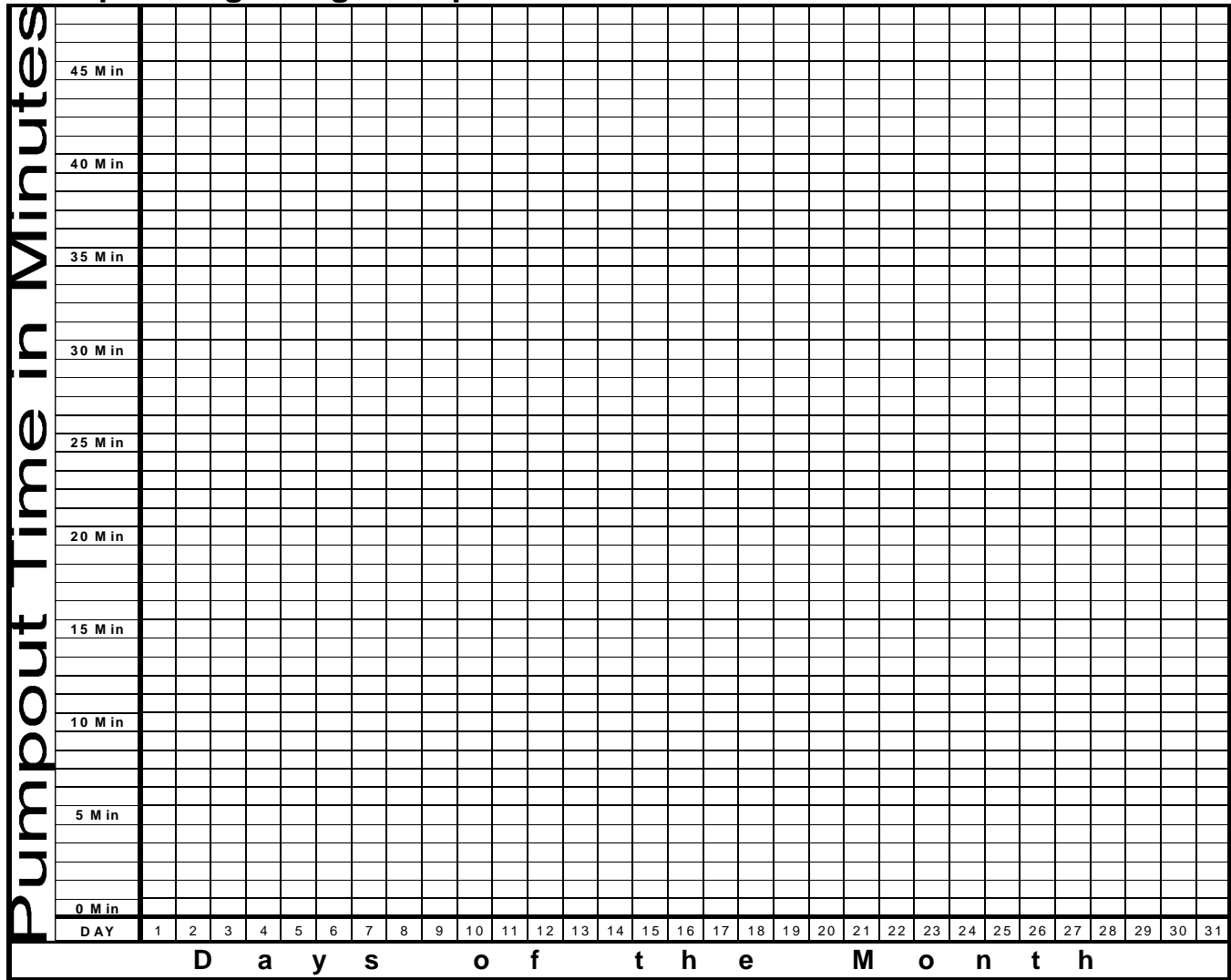

! Record displayed minutes of Pumpout Time below, then plot to visually reflect trends.

Day	Operator	Minutes	Day	Operator	Minutes	Day	Operator	Minutes
1			11			21		
2			12			22		
3			13			23		
4			14			24		
5			15			25		
6			16			26		
7			17			27		
8			18			28		
9			19			29		
10			20			30		
						31		

This Graph/Log may be reproduced for record keeping.

Chiller No. _____ Record for: _____ : _____
 (Month) (Year)

3 Graph & Log - 30-Day Average Purge Pumpout Time Per Day

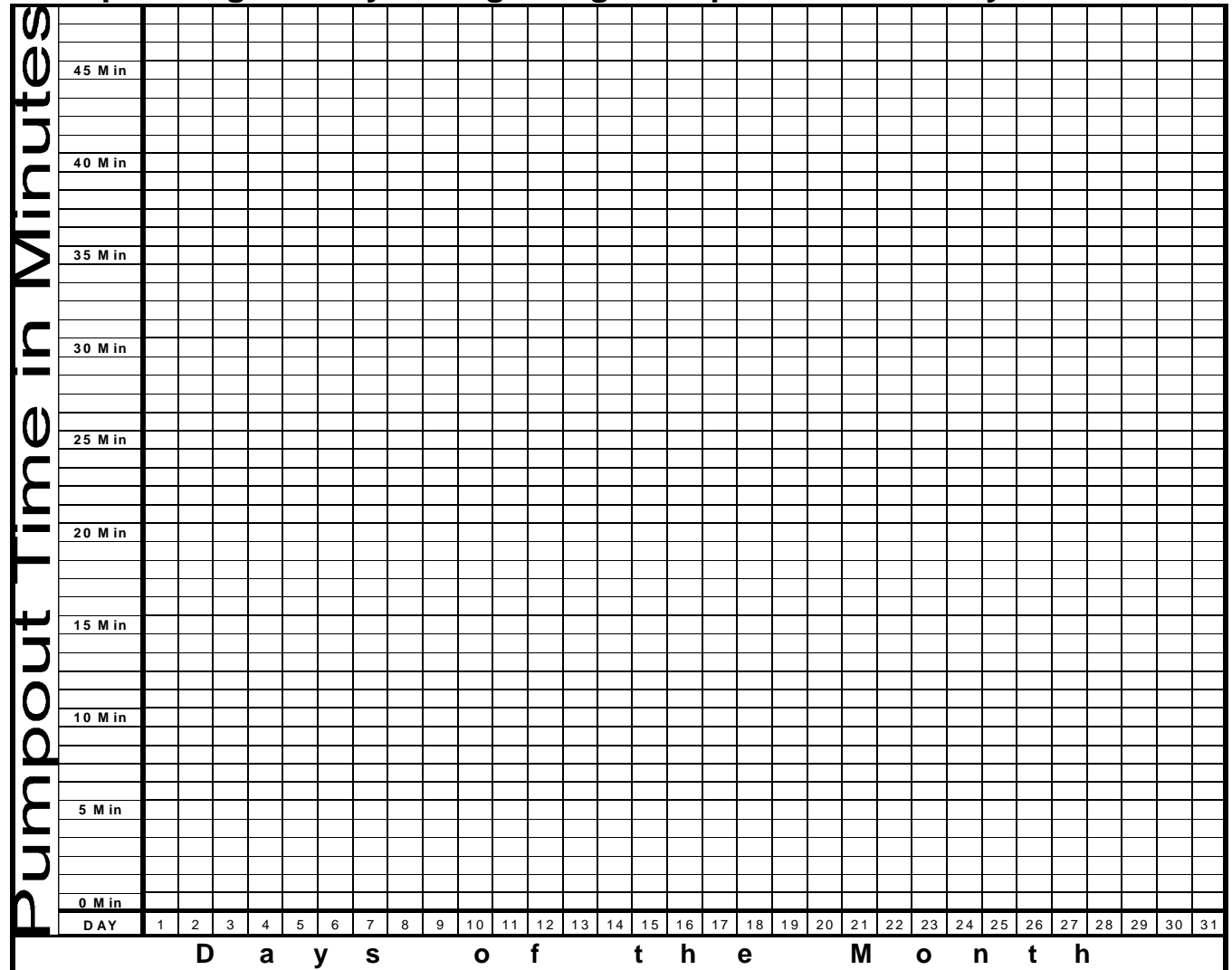

! Record displayed minutes of Pumpout Time below, then plot to visually reflect trends.

Day	Operator	Minutes	Day	Operator	Minutes	Day	Operator	Minutes
1			11			21		
2			12			22		
3			13			23		
4			14			24		
5			15			25		
6			16			26		
7			17			27		
8			18			28		
9			19			29		
10			20			30		
						31		

This Graph/Log may be reproduced for record keeping.

Chiller No. _____ Record for: _____ : _____
 (Month) (Year)

3 Graph & Log - 30-Day Average Purge Pumpout Time - Chiller running

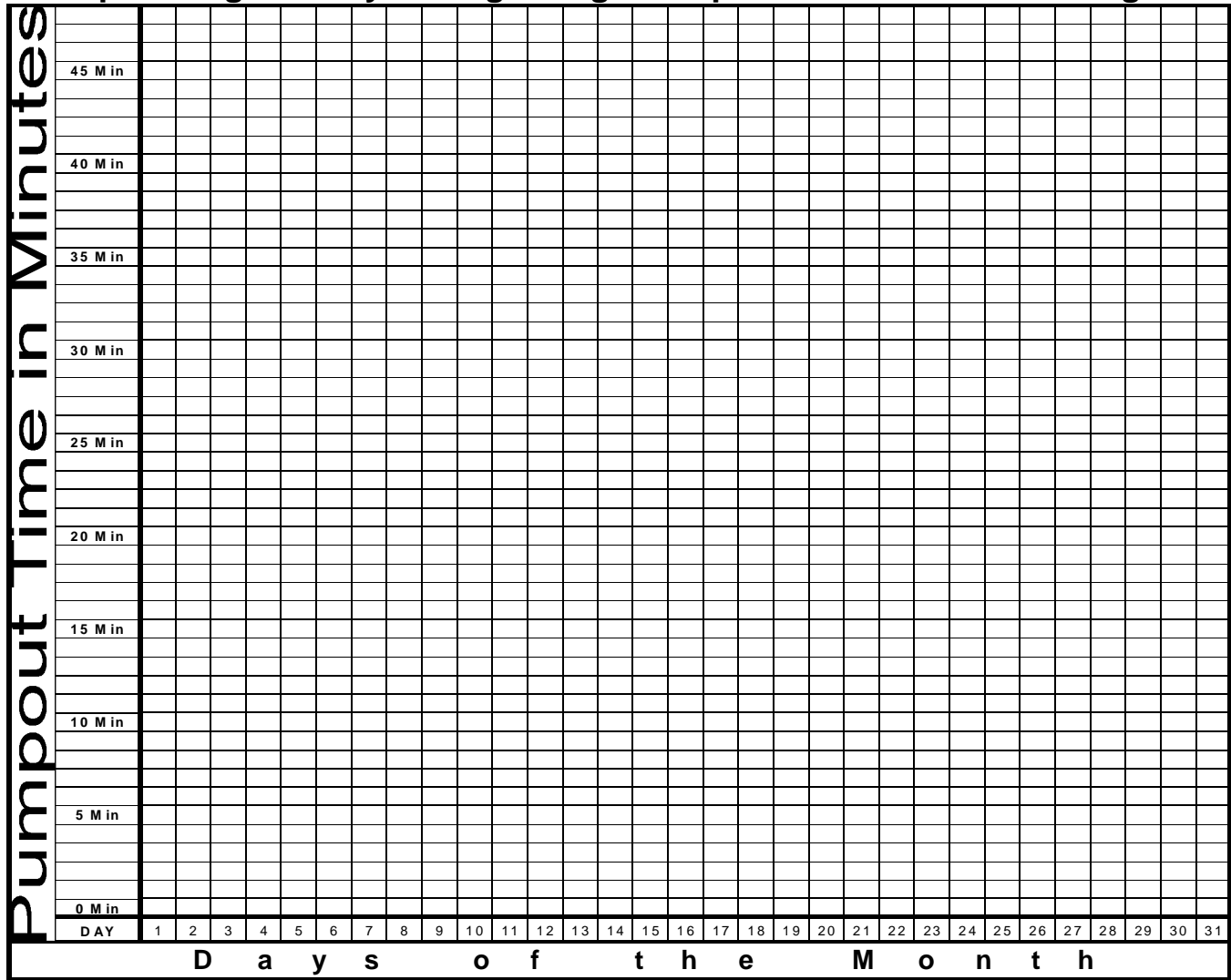

! Record displayed minutes of Pumpout Time below, then plot to visually reflect trends.

Day	Operator	Minutes	Day	Operator	Minutes	Day	Operator	Minutes
1			11			21		
2			12			22		
3			13			23		
4			14			24		
5			15			25		
6			16			26		
7			17			27		
8			18			28		
9			19			29		
10			20			30		
						31		

This Graph/Log may be reproduced for record keeping.

Chiller No. _____ Record for: _____ : _____
 (Month) (Year)

3 Graph & Log - 30-Day Average Purge Pumpout Time- Chiller Off

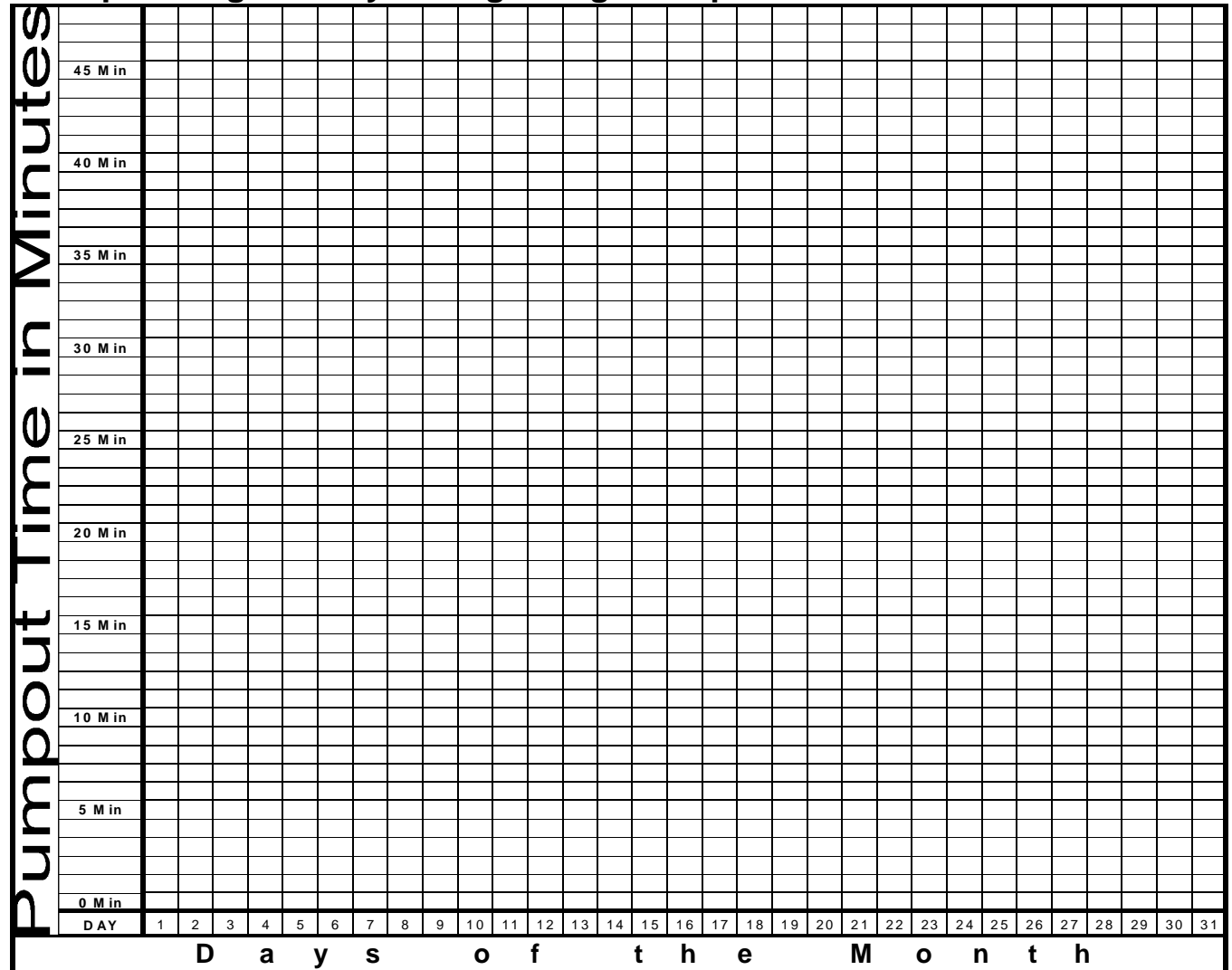

! Record displayed minutes of Pumpout Time below, then plot to visually reflect trends.

Day	Operator	Minutes	Day	Operator	Minutes	Day	Operator	Minutes
1			11			21		
2			12			22		
3			13			23		
4			14			24		
5			15			25		
6			16			26		
7			17			27		
8			18			28		
9			19			29		
10			20			30		
						31		

This Graph/Log may be reproduced for record keeping.

Chiller No. _____ Record for: _____ : _____
 (Month) (Year)

3 Graph & Log - First 3 Hours Pumpout Time after Chiller Shutdown

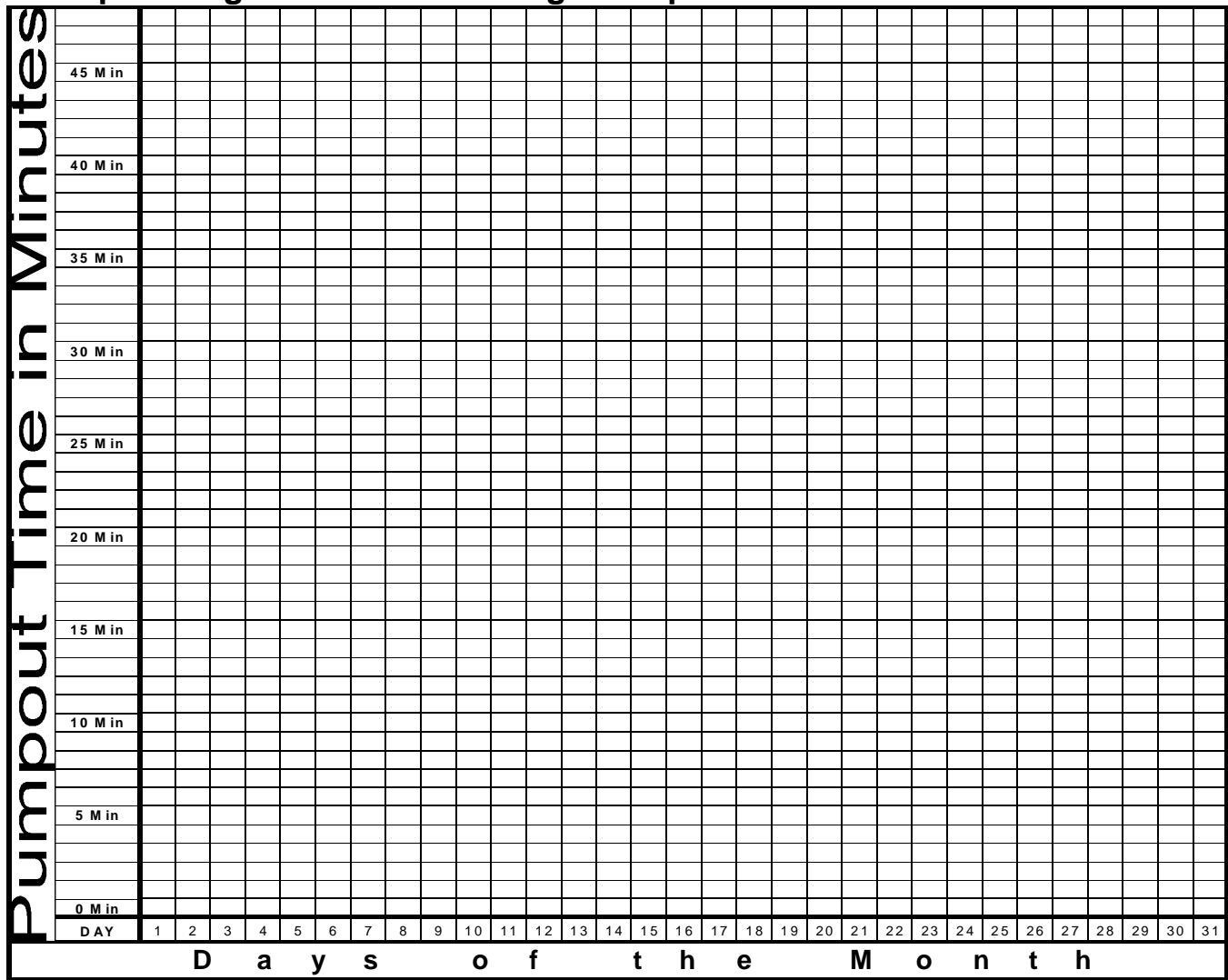

! Record displayed minutes of Pumpout Time below, then plot to visually reflect trends.

Day	Operator	Minutes	Day	Operator	Minutes	Day	Operator	Minutes
1			11			21		
2			12			22		
3			13			23		
4			14			24		
5			15			25		
6			16			26		
7			17			27		
8			18			28		
9			19			29		
10			20			30		
						31		

This Graph/Log may be reproduced for record keeping.

REDI CONTROLS, INC.

Equipment Warranty

Within one year from the date of purchase, REDI CONTROLS will, repair any REDI CONTROLS' product being used by the original purchaser, which is defective due to faulty materials or workmanship. REDI CONTROLS has the right to repair or replace a defective part or replace the entire product.

To file a Warranty claim on any system or component, return the defective unit to the address below, or other location as REDI CONTROLS directs, freight prepaid.

This Warranty does not apply to or cover:

- | Damages beyond REDI CONTROLS' control.
- | Malfunctions that result from failure to properly install, operate or maintain a product in accordance with instructions provided by REDI CONTROLS.
- | Failures of equipment due to abuse, accident or negligence.
- | Instructions, per applicable codes or ordinances, or in accordance with good trade practices.
- | Labor or other charges incurred in removing or reinstalling any REDI CONTROLS product or part.
- | Damages resulting from use of a REDI CONTROLS product for any purpose other than for which it was designed and manufactured.
- | Any implied warranty of merchantability or fitness for any particular purpose, occurring after the Warranty Period.
- | Loss of use, loss of time, inconvenience, rental for substitute products, loss of business, loss of income, or any other consequential damages resulting from use or failure of any REDI CONTROLS product.

Inquiries to: REDI CONTROLS at 755 E. Main Street, Greenwood, Indiana, 46143

REDI CONTROLS, INC.

(317) 865-4130