



YPAL ROOFTOP CONTROL UPGRADE

INSTALLATION INSTRUCTIONS

Supersedes: 100.50-NM2 (1203)

Form 100.50-NM2 (304)

035-13485-000

INTRODUCTION

This instruction covers the installation of additional controls to provide greater unit control and reliability on YPAL rooftop unit. The procedure will require considerable wiring modifications that will include the installation of an additional unit controller (Smart Relay), freeze-stats for the evaporator coil, ambient temperature switch, and new LP switches.

This control enhancement replaces relays that control the operation of the compressors, condenser fans, hot gas solenoid valve, and liquid line solenoid valve. The Smart Relay also will monitor evaporator conditions via the freeze-stat inputs to ensure reliable compressor operation under “low load” conditions. Head pressure control will be improved as the Smart Relay will monitor an outdoor ambient thermostat and directly control the condenser fans on each refrigerant system.

This installation can be performed with one man with the exception of routing the freeze-stat harness from the control panel to the evaporator coil. The technician should pay particular attention to labeling the wires on the fuse panel before starting the procedure

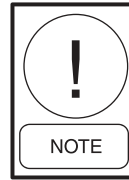

This instruction includes all unit sizes. References to 5R & 6R , 5M & 6M, and 11M & 12M, LLSV3, and associated wiring apply only to YPAL070 through YPAL095 units (six compressor units). YPAL050 through YPAL 065 units (four compressor units) do not use the above referenced components.

Review kit inventory and tool requirements to make certain you have all drawings and components and tools specified for performing this retrofit prior to proceeding to the next step.

TOOLS REQUIRED:

1. Cordless Drill/Driver
2. Magnetic Nut Setter 5/16 & 3/8 inch
3. 6-inch extension attachment for Drill/Driver
4. Wire Fish tape
5. Standard hand tools - Screw Drivers, wire cutter, wire stripper.
6. Multi-meter
7. 3/4” Greenly Punch or Unibit

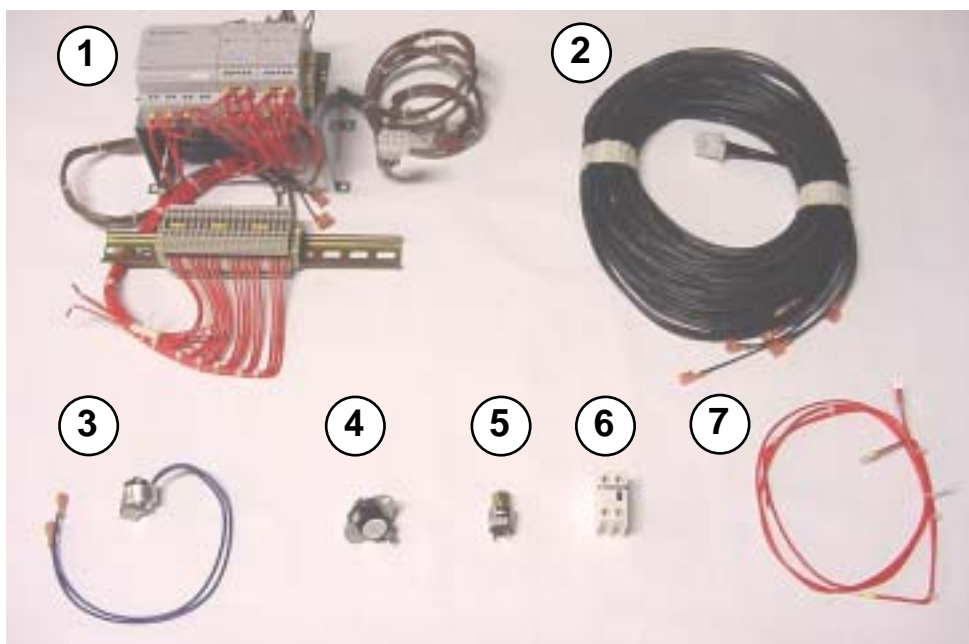

- 1 - Smart Relay Assembly. (1 ea)
- 2 - Freezestat Harness (1 ea)
- 3 - Freezestat -
50-65 ton (4 ea)
70-95 ton (6 ea)
- 4 - Ambient Stat (1 ea)
- 5 - Low Pressure Switch
50-65 ton (2 ea)
70-95 ton (3 ea)
- 6 - Compressor Contactor
Aux. Contact
50-65 ton (4 ea)
70-95 ton (6 ea)
- 7 - Aux. Contact
Power Wire (1 ea)

FIG 1 - MAJOR KIT COMPONENTS

IMPORTANT!

READ BEFORE PROCEEDING!

GENERAL SAFETY GUIDELINES

This equipment is a relatively complicated apparatus. During installation, operation maintenance or service, individuals may be exposed to certain components or conditions including, but not limited to: refrigerants, oils, materials under pressure, rotating components, and both high and low voltage. Each of these items has the potential, if misused or handled improperly, to cause bodily injury or death. It is the obligation and responsibility of operating/service personnel to identify and recognize these inherent hazards, protect themselves, and proceed safely in completing their tasks. Failure to comply with any of these requirements could result in serious damage to the equipment and the property in which it is situated, as well as severe personal injury or death to themselves and people at the site.

This document is intended for use by owner-authorized operating/service personnel. It is expected that this individual possesses independent training that will enable them to perform their assigned tasks properly and safely. It is essential that, prior to performing any task on this equipment, this individual shall have read and understood this document and any referenced materials. This individual shall also be familiar with and comply with all applicable governmental standards and regulations pertaining to the task in question.

SAFETY SYMBOLS

The following symbol is used in this document to alert the reader to areas of potential hazard:



NOTE is used to highlight additional information which may be helpful to you.



CAUTION identifies a hazard which could lead to damage to the machine, damage to other equipment and/or environmental pollution. Usually an instruction will be given, together with a brief explanation.

CHANGEABILITY OF THIS DOCUMENT

In complying with YORK's policy for continuous product improvement, the information contained in this document is subject to change without notice. While YORK makes no commitment to update or provide current information automatically to the manual owner, that information, if applicable, can be obtained by contacting the nearest YORK Applied Systems Service office.

It is the responsibility of operating/service personnel to verify the applicability of these documents to the equipment in question. If there is any question in the mind of operating/service personnel as to the applicability of these documents, then prior to working on the equipment, they should verify with the owner whether the equipment has been modified and if current literature is available.

Revised wiring labels are supplied. Use Table 1 on page 13 to determine which set of wiring labels apply to the specific unit being retrofitted. Apply the new applicable labels over the existing labels in the unit and discard the unused labels. Only the control side labels are affected. There are no changes/replacement to power wiring diagrams



Some units will not have a connection diagram – apply this diagram where space permits.

INSTALLATION PROCEDURE:

1. De-energize all electrical power to unit.
2. Verify power is de-energized with a voltmeter.

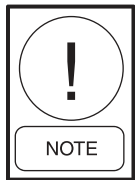

On units with a single point disconnect in the panel and an optional convenience outlet, power is still supplied to the convenience outlet.

3. Perform “Tag Out” procedure to make certain Disconnect Switch is not activated by unauthorized personnel.

REMOVE THE FUSE PANEL

To retrofit the panel and controls, the Fuse Panel must be removed for access to relays 1R thru 6R, located under the panel. The following steps describe removing the Fuse Panel.

1. Identify all fuses located on the fuse panel and associated wires – refer to associated component map and fuse panel drawing supplied in the kit. **Before removing any wires, isolate and label the wires on both the “line” and “load” side of the fuse blocks.** Use the wire labels and Tywraps supplied with the kit. See Fig. 2.
2. Remove wires from the line (top) side of “Fuse Panel” ONLY.
3. Remove 4 self-tapping screws that secure the Fuse Panel to the back-panel of enclosure. One screw is located in each corner of the Fuse Panel. See Fig. 3.
4. Remove Fuse Panel from back panel and carefully fold the fuse panel down out of the way to expose the relays beneath the panel. Secure in place to prevent stress on the wires still connected to the fuse panel. Should any wires come off the fuse panel during this process, they can be easily relocated due to the labeling of the wires in Step #1. See Fig. 4.
5. With the Fuse Panel removed, you can access relays 1R through 6R, from left to right, respectively. See Fig. 5.

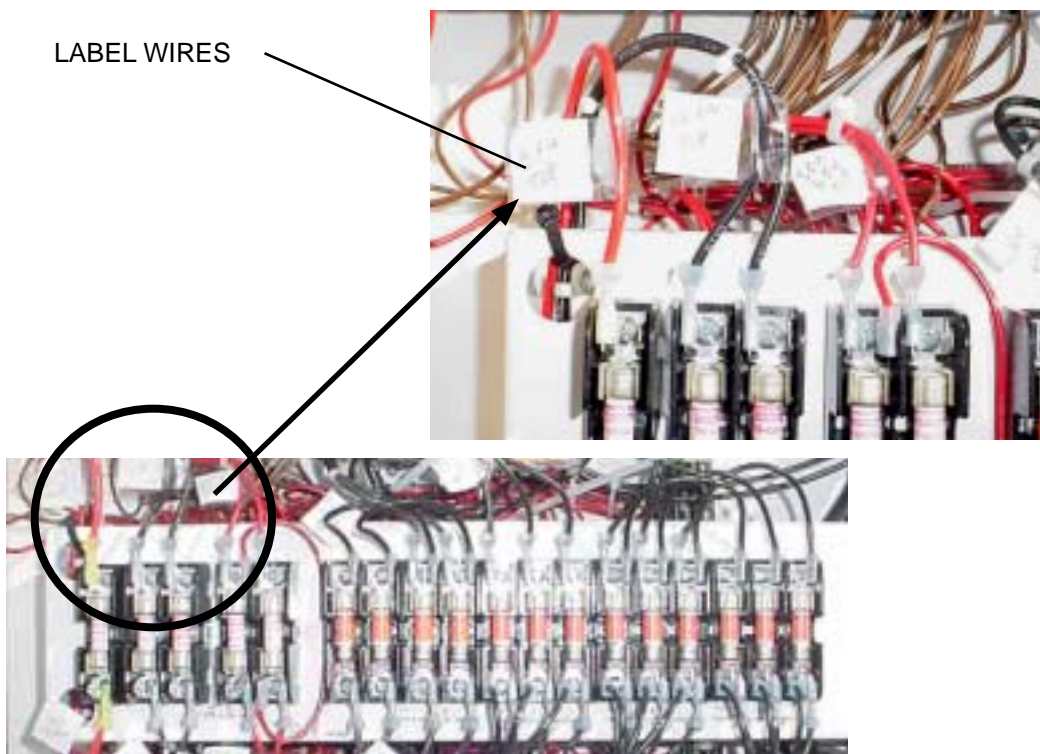

FIG 2 - ISOLATE AND TAG ALL FUSE PANEL WIRES



FIG. 3 - REMOVE FOUR SCREWS SECURING FUSE PANEL



FIG. 4 - FUSE PANEL REMOVED



On four compressor units, only relays 1R through 4R are installed. Disregard references and instructions pertaining to 5R and 6R.

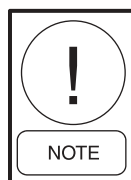

Before mounting the Smart Relay, be sure the mounting location is high enough to allow adequate clearance for the fan panel power wiring between the Smart Relay bracket and the fuse panel bracket (after it is re-installed). See Fig. 7.

INSTALL THE SMART RELAY

1. The Smart Relay should be mounted over the Terminal Block as shown in Fig. 6.

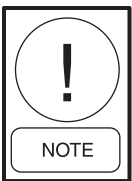

On some panels the location of the terminal block and the T3 transformer may be reversed. In this case, mount the Smart Relay over the terminal block in the alternate location. As a precaution, before installing the Smart Relay, ensure the lugs are tightened on the terminal block.

2. To install the Smart Relay, mark the mounting bracket holes while holding the Smart Relay assembly in the specified mounting location See Fig. 8.
3. Attach the bracket using the supplied 5/16 tech screws (self-tapping screws).
4. Temporarily position the Smart Relay Terminal Block and other associated wires/plugs off to the side until needed later in the installation process.

12R, 13R
RELAYS

1R - 6R
RELAYS

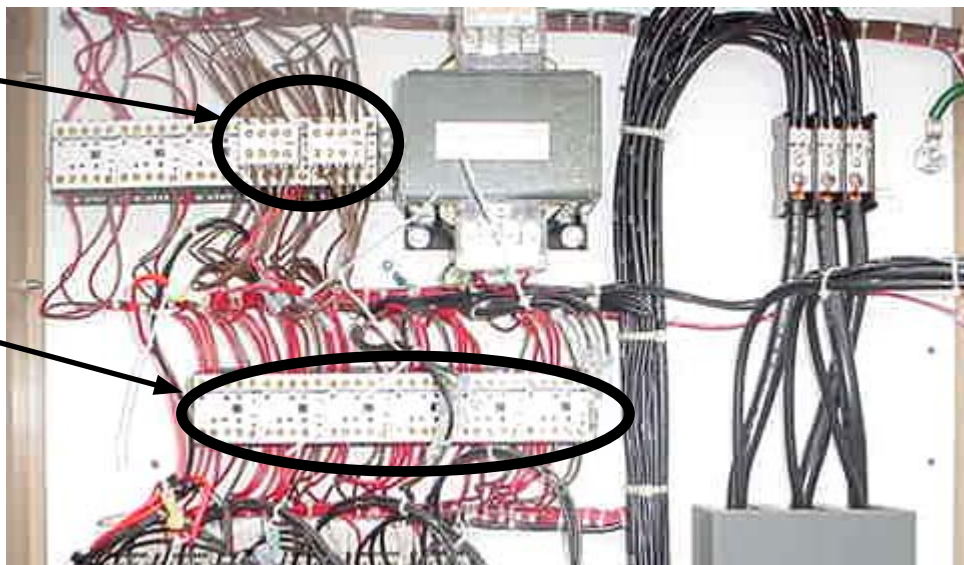

FIG. 5 - LOCATION OF 1R THROUGH 6R RELAYS AND 12R & 13R RELAYS



FIG. 6 - LOCATION OF SMART RELAY

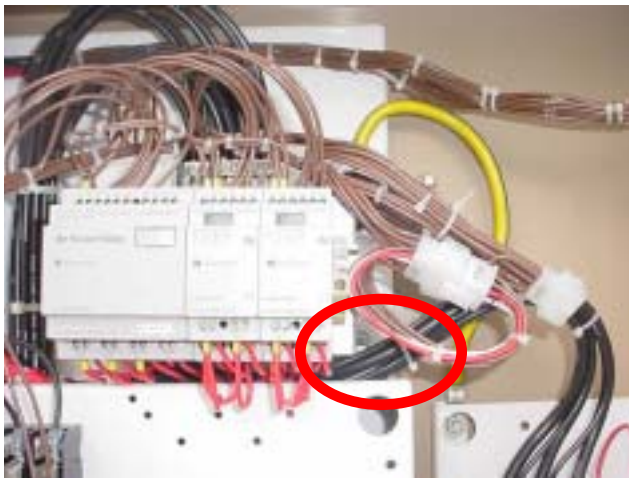

FIG. 7 - MAINTAIN CLEARANCE FOR FAN PANEL WIRING



FIG. 8 - MARKING SMART RELAY BRACKET HOLE LOCATIONS

MODIFYING CONTROL WIRING TO RELAYS 1R THROUGH 6R AND 12R AND 13R

The following procedure describes the process of re-routing, discarding, and rewiring of wires associated with 1R through 6R relays, the 12R and 13R relays. Refer to the supplied Component Map and Wiring Diagram if needed while completing this process.

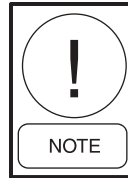

It is extremely important that each step be followed as described and in sequence to ensure a proper installation.

1. Remove wire # 111 from coil (Terminal A1) of Relay 1R.
2. Remove wire # 112 from coil (Terminal A1) of Relay 2R.
3. Remove wire # 113 from coil (Terminal A1) of Relay 3R.
4. Remove wire # 114 from coil (Terminal A1) of Relay 4R.
5. Remove wire # 115 from coil (Terminal A1) of Relay 5R.
6. Remove wire # 116 from coil (Terminal A1) of Relay 6R.
7. The following steps require wires to be removed or pulled through the wiring harness. To easily do this, loosely install Tywraps to make certain the wire harness holds its shape during the retrofit procedure. Cut the factory installed Tywraps along the harness back panel as needed to be able to pull wires through the harness.
8. Pull wires #111 thru #116 out of main wire harness.
9. Carefully remove the top mounted Aux Contact Block of relay 12R & 13R by depressing the blue tabs on the top and bottom of the auxiliary contact block. **Do not alter the wiring of this block.** See Fig. 9.
10. Remove and discard wire # 111 from Terminal 2 of Relay 12R.
11. Remove and discard wire # 112 from Terminal 4 of Relay 12R.

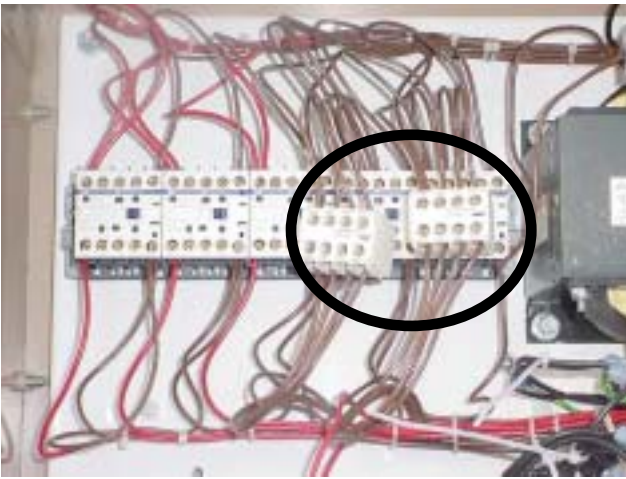

FIG. 9 - 12R & 13R AUXILIARY CONTACT BLOCKS

12. Remove and discard wire # 113 from Terminal 6 of Relay 12R.
13. Remove and discard wire # 114 from Terminal 2 of Relay 13R.
14. Remove and discard wire # 115 from Terminal 4 of Relay 13R.
15. Remove and discard wire # 116 from Terminal 6 of Relay 13R.

TOP OF RELAYS 1R THRU 6R

1. Remove and discard jumper wire # 16 from 1R terminal 21 to 2R terminal 21.
2. Remove and discard jumper wire # 13 from 1R terminal 3 to 2R terminal 3.
3. Remove and discard jumper wire # 23 from 3R terminal 3 to 4R terminal 3.
4. Remove and discard jumper wire # 33 from 5R terminal 3 to 6R terminal 3.

BOTTOM OF RELAYS 1R THRU 6R

1. Remove and discard jumper wire # 31 from 6R terminal 2 to 6R terminal 4.
2. Remove and discard jumper wire # 31 from 6R terminal 2 to 5R terminal 4.
3. Remove and discard jumper wire # 31 from 5R terminal 2 to 5R terminal 4.
4. Remove and discard jumper wire # 21 from 4R terminal 2 to 4R terminal 4.
5. Remove and discard jumper wire # 21 from 3R terminal 2 to 3R terminal 4.
6. Remove and discard jumper wire # 21 from 4R terminal 2 to 3R terminal 4.
7. Remove and discard jumper wire # 12 from 2R

terminal 6 to 2R terminal 22.

8. Remove and discard jumper wire # 11 from 2R terminal 2 to 2R terminal 4.
9. Remove and discard jumper wire # 11 from 1R terminal 2 to 1R terminal 4.
10. Remove and discard jumper wire # 11 from 1R terminal 2 to 2R terminal 2.
11. Remove and discard brown "COM" wire jumper from Terminal A2 of relay coils 1R thru 6R.

TOP & BOTTOM OF RELAYS

1. Remove and discard jumper wire # 12 from 1R terminal 1 to 2R terminal 6.
2. Remove and discard jumper wire # 14 from 2R terminal 1 to 1R terminal 22.
3. Remove and discard jumper wire # 22 from 4R terminal 6 to 3R terminal 1.
4. Remove and discard jumper wire # 32 from 6R terminal 6 to 5R terminal 1.
5. Remove and discard wire # COM to coil 13R terminal A2 that went to the 1R-6R relays. NOTE: there will still be one remaining "COM" wire attached to 13R terminal 2 that did not terminate at the 1R - 6R relays. This remains connected to 13R terminal A2.
6. Disconnect the remaining wires from the relays screw terminals on 1R through 6R.
7. Remove relays 1R thru 6R from panel.

INSTALL THE SMART RELAY TERMINAL BLOCK

1. Remove the existing DIN rail that held the 1R through 6R relays and install the Smart Relay terminal block and DIN rail in the same location. See Fig. 10.

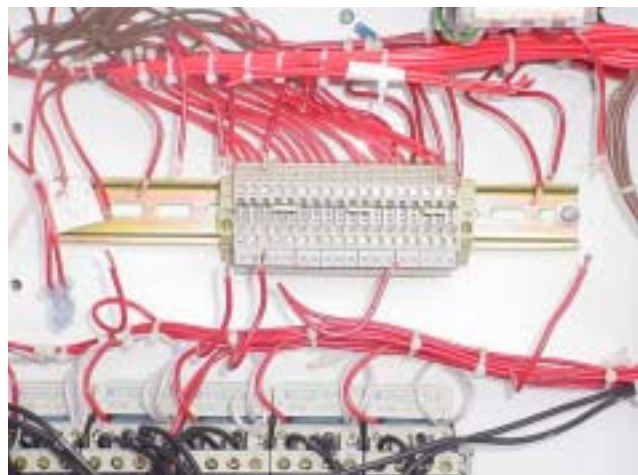
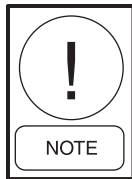

FIG. 10 - LOCATION OF SMART RELAY TERMINAL BLOCK

2. Locate and pull wire # 15, 25 & 35 through the main harness back to P39 and re-route these wires to the bottom-left corner of the power panel, underneath the 1M – 6M contactors. The wires will be connected in a subsequent step under the Liquid Line Solenoid Wiring instruction.



There are two wires labeled #15, 25, & 35. Be sure to get the correct wires.

3. Locate and pull the other wire # 15, 25 & 35 from main harness (these wires MAY be labeled #15B, 25B, 35B). Cut, trim and re-route as required to connect to the Smart Relay Terminal Block Terminals 15, 25 & 35 respectively
4. Locate wire #16 coming from P40 terminal 1 and re-number this wire from #16 to #13A using a wire label supplied in the kit.

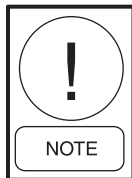

On units without a hot gas option, wire #16 to P40 terminal 1 should be cut and taped-off at the plug.

5. Cut, trim and re-route as required wire # 11, 12, 14, 13 & 13A from main harness and connect to the Smart Relay Terminal Block Terminals 11, 12, 14, 13 & 13A respectively.
6. Cut, trim and re-route as required wire # 21, 22, 24 & 23 from main harness and connect to the Smart Relay Terminal Block Terminals 21, 22, 24 & 23 respectively.
7. Cut, trim and re-route as required wire # 31, 32, 34 & 33 from main harness and connect to the Smart Relay Terminal Block Terminals 31, 32, 34 & 33 respectively.
8. On the Smart Relay wiring harness, locate and cut the Tywrap that is securing the brown harness bundle to the red harness bundle.
9. Locate wires #111, 112, 113, 114, 115, 116 (115 & 116 apply only to six compressor units) coming from the Smart Relay (brown wires) and connect as follows:
 - a. Wire #111 to R12 terminal 2
 - b. Wire #112 to R12 terminal 4
 - c. Wire #113 to R12 terminal 6
 - d. Wire #114 to R13 terminal 2
 - e. Wire #115 to R13 terminal 4
 - f. Wire #116 to R13 terminal 6



FIG. 11 - LOCATION OF PB/JB CONNECTION

10. Re-install R12 and R13 auxiliary contact blocks.
11. Locate the PB/JB connection in the control panel. It is located in the upper left-hand side of the control panel. See Fig. 11.
12. Disconnect the PB/JB connection, and connect PBX from the Smart Relay wiring harness to JB, and JBX from the Smart Relay Harness to PB. See Fig. 12.

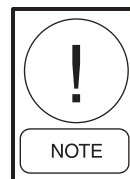

The wiring harness for the Smart Relay will have two capped wires (three on 6 compressor units) “bundled” within the wiring harness. These wires may or may not be visible and are labeled as wires 144, 145, and 146 (6 compressor units only) and have insulated caps terminating the end of the wire. DO NOT REMOVE THE WIRE CAPS OR ATTEMPT TO CONNECT THESE WIRES INTO THE CIRCUIT.



FIG. 12 - CONNECTING SMART RELAY HARNESS



FIG. 13 - INSTALL TOP MOUNT AUXILIARY CONTACTS



FIG. 14 - ENSURE CONTACTOR/TOP MOUNT AUXILIARY CONTACTS FUNCTION

LIQUID LINE SOLENOID WIRING

1. Install the top-mount auxiliary contacts on contactors 1M – 6M (note: 50 – 65 ton units do not have 5M and 6M contactors). See Fig. 13.
2. Ensure that the auxiliary contacts are correctly installed and functional by manually closing the contactor. The contact and auxiliary should operate freely without any binding. See Fig. 14
3. Install three jumper wires (two on 50 – 65 ton as 5M and 6M are not present) supplied with the kit (attached to Smart Relay red wire harness). Install jumper wire #16 from 1M aux contact terminal 53 to 2M aux contact terminal 53. Install jumper wire # 26 from 3M aux contact terminal 53 to 4M aux contact terminal 53. Jumper wire# 36 (six compressor units only) from 5M aux contact terminal 53 to 6M aux contact terminal 53. Refer to Fig. 15 and Component Map, Detail “B”.
4. Re-number wire #15 coming from J39 pin 1 to wire #16B using the one of the labels provided in the kit. Connect this wire to 2M aux contact terminal 54.
5. Re-number wire #25 coming from J39 pin 4 to wire #26B using the one of the labels provided in the kit. Connect this wire to 4M aux contact terminal 54.
6. Re-number wire #35 coming from J39 pin 7 to wire #36B using the one of the labels provided in the kit. Connect this wire to 6M aux contact terminal 54 (only applies to six compressor units).
7. Reinstall the Fuse Panel and install the Auxiliary Contact Power wiring as labeled # 1 (supplied with the kit) from fuse FU5 (same side as wire #1 on 5FU terminal block) to the 1M aux contact terminal 54. Note: this connection is installed under the screw on the 5FU terminal block. Then install the “Daisy chain” jumper wires to 3M aux contact terminal 54, and 5M (six compressor units only) aux contact terminal 54 – refer to detail “B” on the component map.



FIG. 15 - TOP MOUNT AUXILIARY CONTACT WIRING



FIG. 16 - REMOVING WIRE RACEWAY COVER

INSTALLING THE FREEZE-STAT WIRING

1. Remove the louver panel or wire grill below the Power Panel.
2. Remove louver panels or wire grills along the left side of the unit up to the bulkhead of the condensing section to gain access to the wire raceway. The Wire raceway is located on the inside perimeter of the unit along the base rails. Remove the screws securing the wire raceway cover and remove the cover to gain access to the wiring. See Fig. 16
3. The freeze-stat wiring harness will be routed from the control panel to the evaporator coil, starting from the lower-left side of the control panel See Fig. 17.
4. Connect J55 from the Smart Relay wiring harness to the freeze-stat wiring harness. Then route the freeze-stat harness to the evaporator through the raceway to the supply fan section, following the existing wiring path. On units without a heat section, this may require removing the panel to the supply plenum to route wiring harness. Route the freeze-stat harness to the header side of the coil. See Fig. 18 for routing harness.



Ensure this penetration is sealed to prevent unconditioned air from entering the wire raceway and control panel. Failure to do so will result in the formation of condensation in the control panel and raceway

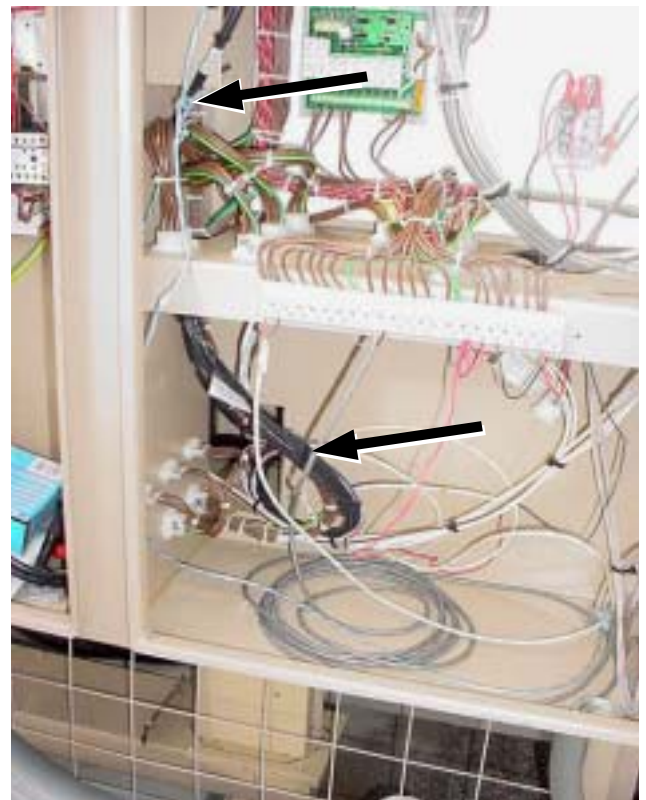

FIG. 17 - FREEZESTAT HARNESS



This penetration must be sealed or leakage of unconditioned air into the supply fan section will cause the formation of condensation on all surfaces.

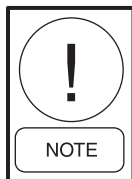

FIG. 18 - ROUTING FREEZESTAT WIRING FROM CONTROL PANEL TO COIL HEADER



FIG. 19 - EXISTING FREEZESTAT MUST BE REMOVED (CONSTANT VOLUME UNITS ONLY)

5. Constant volume units have an existing freeze-stat that must be removed. See Fig. 19.
6. Remove the freeze-stat, cut and tape-off the wires, and attach to existing wiring harness. See Fig. 20
7. Connect each pair of freeze-stats together so they are connected in series. See Fig. 21



Each freezestat should have one male and one female push-on connector. If both connectors are female, replace one of the connectors on each freezestat with a male connector supplied in the kit.



FIG. 20 - REMOVE AND TERMINATE EXISTING FREEZESTAT WIRING (CONSTANT VOLUME UNITS ONLY)

8. Mount the freeze-stats supplied with the kit as shown in Fig. 22. Refer to page 14 for assistance in determining the exact location for mounting of the freezestats. Note that refrigerant system #1 is on



FIG. 21 - FREEZESTAT CONNECTIONS FOR EACH REFRIGERANT SYSTEM

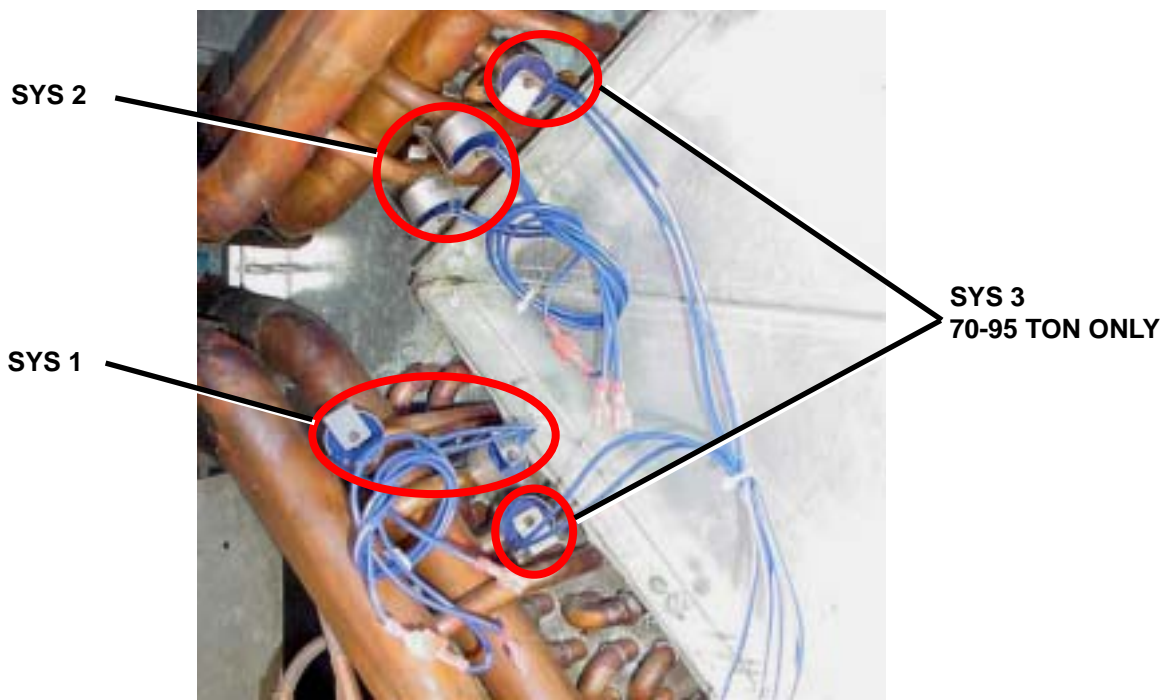
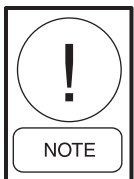

FIG. 22 - FREEZESTAT MOUNTING AND WIRING ON COIL HEADER

the bottom coil, outer and middle headers. Refrigerant system #2 is on the upper coil, outer and middle headers, and refrigerant system #3 (70-95 ton only) is the inner header on the top AND bottom coils.



There may be some differences in the exact position of the feeder tube feeding the suction header. However, the suction header position designation (inner, middle, outer) is always according to the drawings referenced above. It is critical that the following wiring instruction corresponds with the respective refrigerant system freeze-stats.

9. Freeze-stat wiring connections:
 - a. Connect wire #100A from the freeze-stat wiring harness to one end of the “seriesed” freeze-stats on refrigerant system 1. Connect wire #150 from the freeze-stat wiring harness to the remaining wire of the “seriesed” freeze-stat on refrigerant system.
 - b. Connect wire #100B from the freeze-stat wiring harness to one end of the “seriesed” freeze-stats on refrigerant system 2. Connect wire #152 from the freeze-stat wiring harness to the remaining wire of the “seriesed” freeze-stat on refrigerant system 2.

- c. 70 – 95 Ton units only: Connect wire #100C from the freeze-stat wiring harness to one end of the “seriesed” freeze-stats on refrigerant system 3. Connect wire #154 from the freeze-stat wiring harness to the remaining wire of the “seriesed” freeze-stat on refrigerant system 3).
- d. Neatly Tywrap the wiring harness as shown in Fig. 23.



FIG. 23 - FINAL FREEZESTAT WIRING (6-COMPRESSOR UNIT SHOWN)

INSTALLING AMBIENT THERMOSTAT

The outdoor ambient thermostat will be installed in the lower left-hand location of the power panel. See Fig. 24.

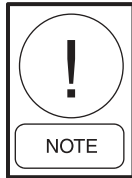

Some units may already have outdoor ambient thermostats installed in this location. On these units:

- Remove the existing outdoor thermostats and install the hole plugs (supplied in the kit) to cover the thermostat mounting holes.
- “Butt splice” the respective wires for each outdoor thermostat.
- Continue to Step 3 below.

1. Drill a pilot hole at the site of Installation for the outdoor thermostat.
2. Using a Unibit or hydraulic punch, knock out a 15/16-inch hole (3/4” Greenly Punch).
3. Drill holes for mounting the outdoor thermostat into the bottom of power panel.
4. Secure the outdoor thermostat in position with 5/16” self tapping screws (supplied).
5. Connect wires #'s 100 and #155 from the Smart Relay to the to the TSTAT.

LP SWITCH INSTALLATION

The refrigerant suction line includes additional Schrader port connections that will permit the installation of the



FIG. 24 - INSTALLATION OF OUTDOOR THERMOSTAT

new LP switch. These ports are located close to the existing LP switch.



Do not remove the existing LP switch as the existing LP switch connection may not have a Schrader core installed!

1. Install the new LP switch on an available suction port.
2. Verify that there are no leaks refrigerant leaks on the LP switch connection
3. Cut the wires on the existing LP switch as close as possible to ensure enough wire length is available to connect to the newly installed LP switch.
4. Connect the wires removed in step #2 to the new LP switch using a butt-splice connection.

TABLE 1 - WIRING LABEL APPLICATION MATRIX

Unit Size	Design Level "A" - (Blue Compressors)		Design Level "B" - (Black Compressors)	
	Wiring Label #	Label Type	Wiring Label #	Label Type
50 - 65 Ton (4 Compr. Units)	035-13422-500	Elementary - Class 1	035-13473-501	Elementary - Class 1
	035-13423-500	Elementary - Class 2	035-13474-501	Elementary - Class 2
	035-13482-500	Component Map Sm Enclosure	035-13475-501	Component Map Sm Enclosure
	035-13484-500	Component Map Lg Enclosure	035-13475-503	Component Map Lg Enclosure
	035-13466-001	Fuse Panel Label	035-13466-001	Fuse Panel Label
	035-13466-003	Fuse Panel Label	035-13466-003	Fuse Panel Label
70 - 95 Ton (6 Compr. Units)	035-13426-500	Elementary - Class 1	035-13473-502	Elementary - Class 1
	035-13427-500	Elementary - Class 2	035-13474-502	Elementary - Class 2
	035-13482-501	Component Map Sm Enclosure	035-13475-502*	Component Map Sm Enclosure
	035-13484-501	Component Map Lg Enclosure	035-13475-504	Component Map Lg Enclosure
	035-13466-002	Fuse Panel Label	035-13466-002	Fuse Panel Label
	035-13466-004	Fuse Panel Label	035-13466-004	Fuse Panel Label

* 70 - 85 Ton Only

FREEZESTAT CONTROL LOCATIONS

Typical arrangements are shown. However, exact feeder tube location may vary. The freezestat must be applied to the correct system suction header.

NOTES:

1. Freezestat clips will snap into place on header tube (shown).
2. Use heat transfer compound under each freezestat.
3. Each freezestat should contact tube and not adjacent tubes or other freezestats.

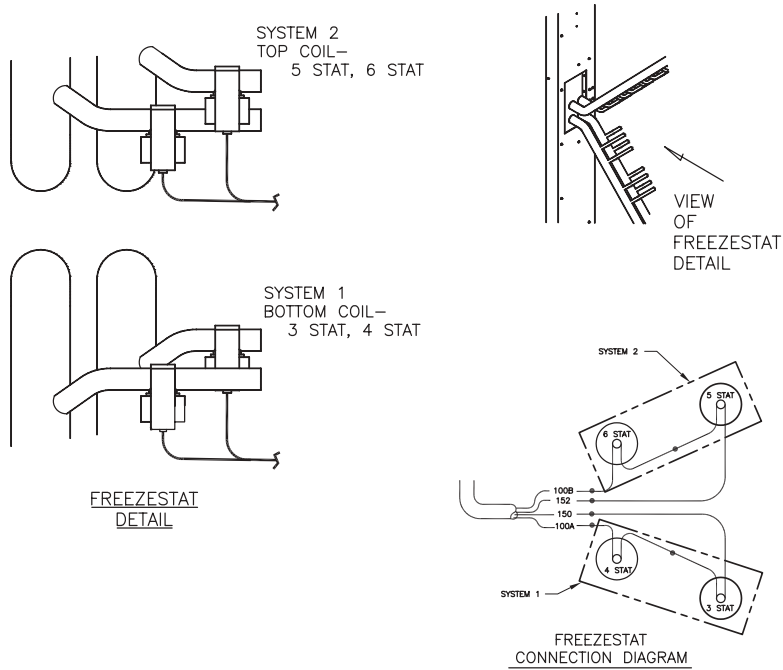

50-65 Ton Models

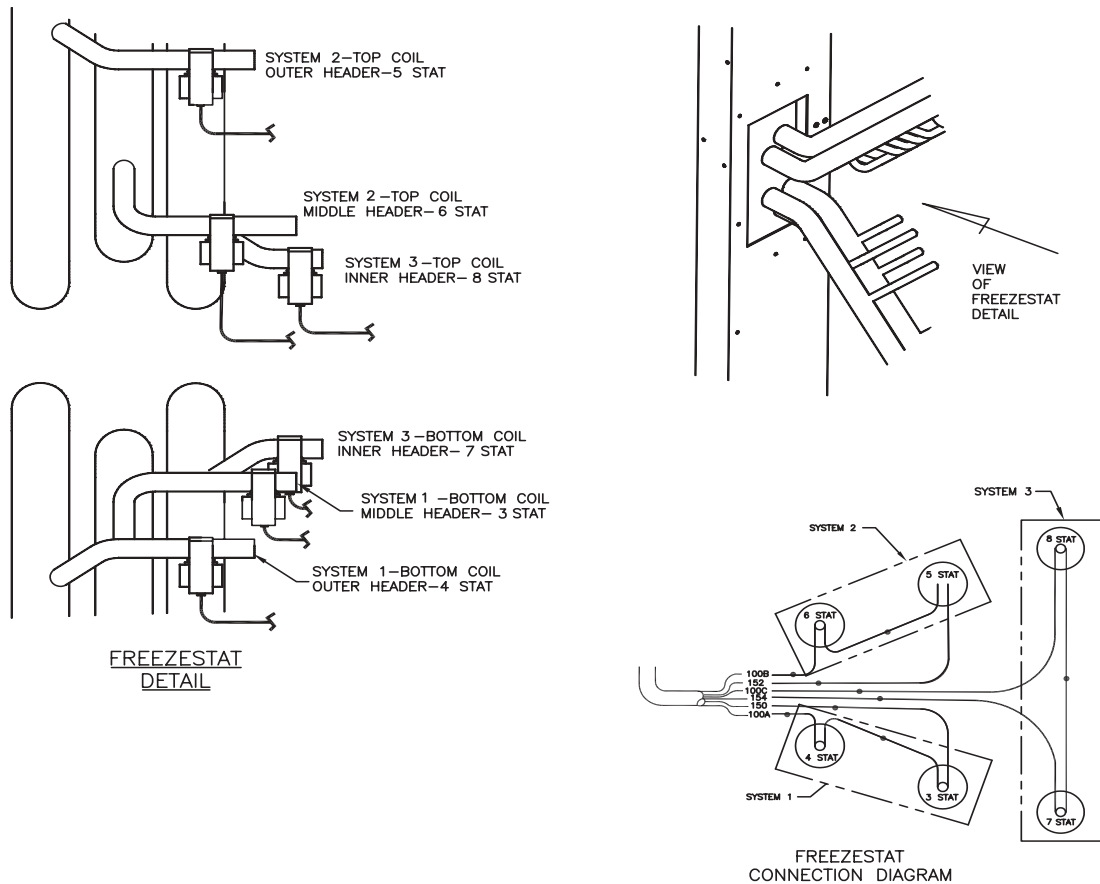

70-95 Ton Models

TRANSIENT SUPPRESSOR INSTALLATION

Install a transient suppressor across the coil of the each liquid line solenoid valve and hot gas bypass valve. The suppressors (electrocube) are included in the kit.

1. Remove the wiring cover from the liquid line solenoid or hot gas solenoid.
2. Remove the existing connectors and install the suppressor with wire nuts or butt-slice connector.
3. Re-install the wiring cover.

FINAL UNIT CHECK-OUT

Applying Power to the Unit

1. Before reapplying power, verify that there are no loose/exposed wires hanging in the panel.



Before re-applying power, verify that there are no exposed or loose wires in the panel. Failure to do so poses a shock hazard and could result in serious injury or death.

2. Ensure that the unit RUN/STOP switch on the Opti-Logic panel is in the STOP position.
3. Apply power to the unit and verify that the OptiLogic panel goes through its self-check and resumes normal operation – this process takes approximately 5 minutes. Normal operation is indicated by the ability to navigate through the various displays using the keypad.

Verify the Freeze-Stat Connections

Each refrigerant system freeze-stats must be checked to verify proper installation by removing disconnecting/reconnecting one of the wires on the respective refrigerant system and verify that the wiring and placement of the freeze-stats was completely accurately. Reference the Component Map supplied in this “Kit” as needed.



INCORRECT FREEZE-STAT WIRING/ LOCATION CAN RESULT IN COMPRESSOR FAILURES.

1. Using a voltmeter, verify that 24 vac is present at the Smart Relay on each freeze-stat input.
 - a. Refrigerant System One Input – Input I3 , wire 150

- b. Refrigerant System Two Input – Input I3 (expansion module #1), wire 152
- c. Refrigerant System Three Input (six compressor models only) – Input I3 (expansion module #2), wire 154.

2. Using a voltmeter, verify that Refrigerant System One input on the Smart Relay (wire 150) drops to zero volts when one wire on the series freeze-stats for System One is disconnected. Reconnect the wire after verification.
3. Using a voltmeter, verify that Refrigerant System Two input on the Smart Relay (wire 152) drops to zero volts when one wire on the series freeze-stats for System Two is disconnected. Reconnect the wire after verification.
4. Using a voltmeter, verify that Refrigerant System Three input on the Smart Relay (wire 154) drops to zero volts when one wire on the series freeze-stats for System Three is disconnected. Reconnect the wire after verification.

Unit Sequence of Operation

The unit can be put into a Run Test to verify that all the compressors and condenser fans sequence in the proper order. The compressors and condenser fans will cycle-on in order, System One through System Three. Each Compressor will cycle-on with ONE condenser fan in that system for three minutes, and then cycle off. The next compressor/condenser fan in the sequence will come on 30 seconds after the last compressor/condenser fan has shut down. This will continue until each compressor has been cycled on.

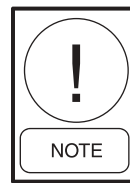

The 2nd condenser fan in each refrigerant will not come on during this run test due to the run test sequence.

1. Turn the RUN/STOP switch to RUN and initiate the RUN TEST as follows:
 - a. Press the Configuration key, and then navigate to the “RUN TEST” by pressing the NEXT key. The display will show *RUN TEST = OFF*
2. Press the CHANGE/ENTER. The display will prompt you for the L2 (level 2) password. Enter 9725 as the password and press the CHANGE/ENTER key. This will put you in the *EDIT MODE*

(shown on line 1 of the display) and allow the RUN TEST to be programmed.

3. In the Edit Mode, and with the cursor blinking under OFF, using the UP/DOWN arrow on the keypad to change the RUN TEST = OFF, to RUN TEST = ON. Press the CHANGE/ENTER key to initiate the RUN TEST.



Reference the eco² IOM or Quick-Start guide for more details on changing set-points if required.

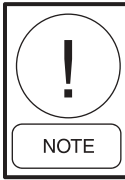

4. After verifying that the correct compressor/condenser fan sequence is correct, recycle power to the unit to stop the Run Test and verify that the unit returns to “normal” operation.

The second condenser fan will only come during normal unit operation when both compressors are running on the respective refrigerant system AND the ambient thermostat is closed (opens at 75° F and closes at 85° F ambient temperature). However, this check should not be necessary if the RUN TEST was successful as described above.





YPAL ROOFTOP CONTROL UPGRADE

INSTALLATION INSTRUCTIONS

Addendum

Form 100.50-NM2 (1203)

035-13486-000

ADDENDUM A

This Addendum Only Applies To Units That Have Black (Copeland) Compressors Along With Suction Line Pressure Transducers

FOLLOW THE PROCEDURES OUTLINED IN THIS ADDENDUM IN LIEU OF THE PROCEDURES CONTAINED IN THE INSTALLATION INSTRUCTIONS FOR THE INSTALLATION OF THE LP SWITCH. THIS IS REQUIRED BECAUSE THE ABOVE UNITS DO NOT HAVE AN AVAILABLE ACCESS PORT FOR THE CONNECTION OF THE LP SWITCH.

LP SWITCH INSTALLATION

1. Remove the transducer from the Schrader fitting on the suction line.
2. Install a tee (not included with kit) with a 1/4" Fe SAE swivel nut on one end of the run with a 1/4" Ma SAE connection on the branch and other end of the run. Use Grainger stock number 3GD02 or equivalent (any equivalent part must have a Schrader valve depresser on the female connection and a Schrader valve core on both male ends of the tee). Make sure the 1/4" Ma connections have a Schrader valve core installed. If not install a Schrader core in the two male connections.
3. Connect the female connection of the tee to the Schrader connection on the suction line.
4. Reconnect the transducer removed in step 1 to one of the male connections of the tee.
5. Install the new LP switch from the kit on the other male connection of the tee.
6. Verify there are no refrigerant leaks at any of the tee connections.
7. Cut the wires on the existing LP switch, as close to the switch as possible, to ensure there is enough wire length available to connect to the newly installed LP switch.
8. Connect the wires removed in step 6 to the new LP switch from the kit using butt-splice connections.



YPAL ROOFTOP CONTROL UPGRADE

INSTALLATION INSTRUCTIONS

Addendum B

Form 100.50-NM2 (1203)

ADDENDUM B

IMPORTANT! READ BEFORE PROCEEDING!

THIS ADDENDUM APPLIES TO ALL UNITS
WITH SINGLE POINT POWER AND A CONVENIENCE OUTLET



The fuse holder and fuses (9FU) to the right of the compressor contactors have line voltage applied to them even when the disconnect switch is in the open position.

Step 2 of the instructions, under the “REMOVE THE FUSE PANEL” heading, requires you to remove the wires from the (top) of the “Fuse Panel”. Wire “X1” on the left hand fuse (10FU) is hot, 120 volts. Care must be taken in removing this insulated flag terminal from the fuse block. After the wire is removed electrical tape should be applied to the terminal to prevent accidental contact with the end of the terminal. After the wire is removed the fuse block panel does not have any voltage applied to it.



YPAL ROOFTOP CONTROL UPGRADE

INSTALLATION INSTRUCTIONS

Addendum C (304)

Form 100.50-NM2 (1203)

ADDENDUM C

THIS ADDENDUM ONLY APPLIES TO UNITS EQUIPPED WITH BLACK (COPELAND) COMPRESSORS

Follow the procedures in this addendum in lieu of the procedures contained in the installation instructions

On Page 7, substitute the following procedures for steps 2 & 3.

2. Locate and pull wire #15, 25 & 35 through the main harness back to the P39 connector. Cut off each of the above wires to a 3 inch length and place a wire cap on the end of the wire.
- 3a. Remove wire # 15, 25, &35 from the ambient thermostat installed in the lower left-hand section of the power panel.
- 3b. These wires will be attached to the auxiliary contacts as described in paragraph 4, 5, and 6 on page 8 of the instructions.
- 3c. Remove wire # 15B, 25B & 35B from the other terminal of the ambient thermostat installed in the lower left-hand section of the power panel and re-route the wires to the area of the Smart Relay Terminal Block.
- 3d. Strip the wires ½ inch and connect them to terminals 15, 25, and 35 of the Smart Relay Terminal Block.

On Page 13, substitute the following procedure for steps 1 thru 5.

INSTALLING AMBIENT THERMOSTAT

1. Remove the three ambient thermostats in the lower left hand section of the power panel.
2. Install the outdoor thermostat (supplied in the kit) in one of the holes.
3. Place the hole plugs (supplied in the kit) in the other two holes.
4. Connect wires #'s 100 and 155 from the Smart Relay to the thermostat installed in step 2 above.