



Form S90-130 I (OCT 2004)

INSTALLATION

File: SERVICE MANUAL - Section 90
Replaces: NOTHING (New Information)
Dist: 3, 3a, 3b, 3c

**RETROFIT CONVERSION
TO THE
FRICK® QUANTUM™ LX CONTROL**

INSTALLATION INSTRUCTIONS



FRICK® QUANTUM™LX RETROFIT PANELS

The *QUANTUM™LX* Control Panel sold under this program is designed to handle standard screw compressor package design. Compressors are to be electric motor driven only. Other drive lines can be accommodated through Frick® Engineering. Lubrication is accomplished by electric motor or shaft driven oil pumps, or differential pressure lube systems. If the compressor package does not meet these basic requirements, contact Frick® for Engineering assistance. Frick® can make the proper changes for most applications, but there will be an Engineering charge.

In some cases, even though the screw compressor package meets the basic requirements, package modifications and/or control panel modifications may be required, such as: modified piping, additional solenoids and check valves, and additional relays into the control circuits. This is the case with most vertical separators, screw chiller packages, and other specific-duty screw compressor packages. Normally, an experienced installer can handle these items in the field. Contact Frick® Engineering for assistance if a problem is encountered.

The *QUANTUM™LX* Control Panel will be offered in a “kit” form which will supply the panel, drawings, and the current installation and operation manual. Pressure transducers, temperature probes, and slide valve indicator potentiometers and assemblies are optional items and must be ordered separately, if required.

INTRODUCTION

CONVERSION OF SCREW COMPRESSOR UNITS TO THE FRICK® QUANTUM™LX CONTROL PANEL.

These instructions are based on the installer having a fundamental knowledge of refrigeration design and installation. Instructions are for conversion to the standard design unit. Special package and/or control modifications furnished on the existing unit will require deviation from these instructions. Contact Frick® if you have any questions, concerns or problems. Frick® does not take responsibility for the suitability of these instructions, for any nonstandard installation or for consequential damages resulting from the conversion.

DO NOT INITIATE RETROFIT CONVERSION UNTIL YOU HAVE COMPLETELY REVIEWED ALL INSTRUCTIONS AND CHECKED MATERIAL RECEIVED FOR SUITABILITY AND COMPLETENESS.

Instructions are provided for retrofit conversion from either RWB Electromechanical or RWB II Microprocessor Control to *QUANTUM™LX* Control. Other screw compressors not manufactured by Frick® can also be converted to the *QUANTUM™LX* Control. Frick® screw compressor packages, where the compressor itself was not manufactured by Frick®, are considered to be in this “other manufacturers” category.

Material furnished by Frick®, in addition to this Instruction Manual and the Frick® Operation and Maintenance manuals (S90-020 O and S90-020 M), are as follows:

- A. Complete *QUANTUM™LX* control panel.
- B. Optional pressure transducers with pressure block plus temperature probes with wells:

WHEN CONVERTING FROM:	TO:	OPTION REQUIRED
RWB Electromechanical	QUANTUM LX	YES
Other Manufacturers	QUANTUM LX	YES
RWB II Micro	QUANTUM LX	NO
RXB Plus Micro	QUANTUM LX	NO
RXF Plus Micro	QUANTUM LX	NO
RXF Micro	QUANTUM LX	NO
RDB Plus Micro	QUANTUM LX	NO
RDB Electromechanical	QUANTUM LX	YES

- C. Optional 1000 OHM rotary slide valve indicator potentiometer:

WHEN CONVERTING FROM:	TO:	OPTION REQUIRED
RWB Electromechanical (with Dunham Bush version E and later compressors)	QUANTUM LX	YES
Other Manufacturers (Without 1000 OHM potentiometer)	QUANTUM LX	YES
RWB Electromechanical (with Dunham Bush version A through D compressors)	QUANTUM LX	NO
RWB II Micro	QUANTUM LX	NO
Other Manufacturers (With 1000 OHM potentiometer)	QUANTUM LX	NO
RXB Plus Micro	QUANTUM LX	NO
RXF Plus Micro	QUANTUM LX	NO
RXF Micro	QUANTUM LX	NO
RDB Plus Micro	QUANTUM LX	NO
RDB Electromechanical	QUANTUM LX	YES

- D. Optional slide valve indicator assembly:

WHEN CONVERTING FROM:	TO:	OPTION REQUIRED
RWB Electromechanical (with Dunham Bush version A through D compressors)	QUANTUM LX	YES
All except above	QUANTUM LX	NO

- E. Optional 1000 OHM linear slide valve indicator potentiometer:

WHEN CONVERTING FROM:	TO:	OPTION REQUIRED
RXB Electromechanical	QUANTUM LX	YES

REQUIRED MATERIAL TO BE SUPPLIED BY INSTALLER.

- A. Pressure tubing and fittings (1/4 inch stainless steel)
- B. Pipe, fittings, and adaptors, if required
- C. Electrical conduit, fittings, and solenoids
- D. Wire
- E. Current transformer in the compressor motor starter, control transformer, and any motor starter components or modifications.
- F. Labor and tools required to complete installation and start-up.

INSTRUCTIONS

NOTE: Before proceeding, read the instructions for "Proper Installation of Electronic Equipment in an Industrial Environment" on page 7.

1. Push **[STOP]** key to shut down the unit. Open the disconnect switch for the compressor motor starter and (if applicable) oil pump motor starter. 
2. Close the discharge, and liquid injection (if applicable) service valves.
3. **SLOWLY** vent the separator to low-side system pressure using the suction check valve bypass. Close suction valve and suction check valve bypass. **NOTE: Recover or transfer all refrigerant vapor in accordance with local ordinances before opening to atmosphere.** The separator **MUST** be equalized to atmospheric pressure.



Oil-entrained refrigerant may vaporize, causing a separator pressure increase. Repeat venting and recovery procedure if necessary.

4. Drain the oil from the oil separator if an oil separator temperature probe well is to be installed.
5. Remove the existing panel from the compressor package. **DO NOT CUT WIRES OR TUBING LINES.** They will be used to connect to the new panel.
6. If converting from an RWB II to a *QUANTUM™ LX*, remove the front panel assembly. Remove wires on the I/O board which run from the micro enclosure to the junction box. Remove the analog wires from the FRK-1 board. Remove ground, +5VDC, ±12VDC and +24VDC from the FRK-1, SBC and I/O boards. Be sure all of the above wires are labeled because all except ±12VDC and +24VDC will be connected to the *QUANTUM™ LX*.
7. Remove existing thermometers, temperature switches and pressure switches (if applicable) from the compressor package.
8. Mount the *QUANTUM™ LX* panel on the compressor package by bolting the panel to the existing panel mounting structure. It may be necessary to weld new panel mounting brackets to the screw compressor package to accommodate the proper panel height. If so, **DO NOT WELD TO THE PRESSURE VESSEL.** Weld only to existing mounts or other

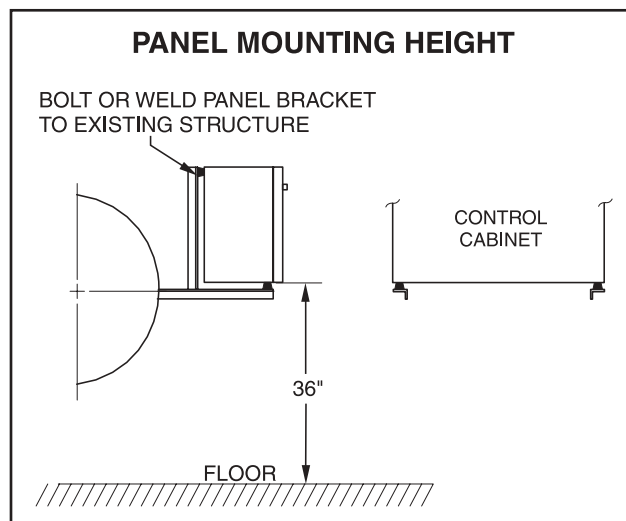

structural material. **DO NOT WELD WITH THE CONTROL PANEL IN PLACE.** Welding currents can cause damage to the electronic components. Refer to the PANEL MOUNTING HEIGHT diagram below.

9. Install the temperature probe wells at the locations indicated on the TRANSDUCER CONNECTION DIAGRAM. Existing connections may require reducers to fit the new temperature wells. Some of the required locations may not have a connection available and will require cutting a hole and welding in a connection for the temperature well. Seal all threaded connections to prevent leaks.
10. Place silicone heat transfer compound on the tip of the temperature probes and install them in the temperature wells.
11. Run separate electrical conduit between the control panel and the temperature probe electrical boxes. **DO NOT RUN THE TEMPERATURE PROBE WIRING WITH THE AC CONTROL WIRING.**
12. The wiring between the control panel and the temperature probes must be shielded twisted-pair wire. Belden part number 8761 or equivalent is recommended.
13. Refer to the panel wiring diagrams in the S70-200 IOM and connect the white wire of the twisted pair to the nonblack temperature probe wire. The temperature probe wire colors may vary on this wire. Connect the black wire of the twisted pair to the temperature probe black wire. Cut off the shield wire on the temperature probe end and place tape or heat shrink tubing around the exposed shield so that it will not come in contact with the electrical box.
14. Connect the shield wire of the twisted pair to the control panel ground block in the control panel.
15. Connect the white and black twisted-pair wires to the microprocessor board, as shown on the panel wiring diagrams in the IOM.
16. Install stainless steel tubing from the points indicated in the TRANSDUCER CONNECTION DIAGRAM to the pressure transducer pressure block located behind the control panel. Properly brace all pressure lines so that excessive vibration will not cause transducer error. **DO NOT PLACE VALVES BETWEEN DISCHARGE OR OIL LINES AND THE PRESSURE TRANSDUCER.**
17. Refer to the panel wiring diagrams in the Maintenance manual (S90-020 M) and connect the red, black, and white wires of the pressure transducers to the *QUANTUM™ LX* analog board. The shield of the transducer cable is grounded inside the transducer and should not be grounded inside the cabinet.
18. Determine if there is a slide valve potentiometer on the slide valve indicator assembly. If a potentiometer is provided, it should be 1,000 OHMS single turn or 10,000 OHMS ten turn with a calibration resistor. If a potentiometer is not provided, contact Frick for ordering proper potentiometer and drive assembly.
19. Run separate electrical conduit between the control panel and the slide valve indicator assembly. **DO NOT RUN SLIDE VALVE WIRING WITH AC CONTROL WIRING.**
20. The wiring between the control panel and the slide valve indicator must be shielded twisted-three wire. Belden part number 8770 or equivalent is recommended.

21. Refer to the panel wiring diagrams in the Maintenance manual (S90-020 M) and connect the red, black, and white wire of the twisted-three wire to the slide valve potentiometer. Cut off the shield wire at the slide valve indicator end and place tape or heat shrink tubing around the exposed shield so that it will not come in contact with the compressor or slide valve cover.

22. Connect the shield wire of the twisted-three wire to the control panel ground block in the control panel.

23. Connect the red, black, and white twisted-three wires to the microprocessor board, as shown on the panel wiring diagrams in manual S90-020 M.

24. If the compressor is an RWB II model, locate the slide stop potentiometer. Verify that the existing wiring between the slide stop potentiometer and control panel is wired with Belden 8770 or equivalent.

25. Refer to the panel wiring diagrams in the manual S90-020 M and verify that the red, black, and white wires of the twisted-three wire to the slide stop potentiometer are wired properly. Verify that the shield wire at the slide stop end is cut off and taped to prevent contact with the compressor. Leave slide stop cover off until the calibration procedure is complete.

26. Connect the red, black, and white twisted-three wires to the microprocessor board, as shown on the panel wiring diagrams in the manual S90-020 M.

27. Connect the shield wire of the twisted-three wire to the control panel ground block in the control panel.

28. Before starting the AC control wiring, the following items should be checked in the compressor starter. Refer to the compressor motor starter diagrams.

A. The compressor requires a minimum of 2 KVA transformer for 120 VAC control and heater power.

B. The compressor starter must have a ground wire pulled from the three-phase source. The ground must be connected to the starter backplate and the neutral terminal (2) on the secondary side of the control transformer.

C. Verify that the current transformer (CT) is placed as shown on the motor starter diagram in the IOM and is sized according to the current transformer (CT) selection chart.

D. Verify that auxiliary contacts are provided on the compressor and oil pump contactor (if oil pump is required).

E. Verify that the compressor motor overloads are sized properly.

F. If the compressor and oil pump starters do not have interposing relays already provided, the relays must be mounted and wired as shown on the drawings.

G. If converting from an RWB II to a QUANTUM™LX, connect the motor amp signal from the current transformer in the motor starter (wires 3 and 4) directly to the analog board in the QUANTUM™LX panel. On the RWB II, the number 3 and 4 wires were connected to a current transducer in the junction box. The best way to get the CT signal + from the junction box to the QUANTUM™LX enclosure is to use the number 12 gauge blue and black wires which were used for common and +5VDC.

The most common electronic control panel problems are due to undersized AC power wiring, poor grounds, and control power supplied from lighting panels that have other devices tied to them that generate large amounts of AC line noise. Please follow these directions carefully. (For additional information on "Installation of Electronic Equipment in an Industrial Environment", see page 7)

Metal oxide varistors (MOV or surge suppressor) are recommended for the load/unload solenoid coils, compressor starter coil, oil pump starter coil (if applicable) and liquid injection solenoid coil (if applicable). The MOVs should be placed directly at the coils of these devices. Placement of the MOVs at the control panel terminal strip negates the surge suppression effect. For 100 VAC to 125 VAC operation, a General Electric part number V130LA10A is recommended. For 185 VAC to 254 VAC operation, a General Electric part number V275LA20A is recommended.

29. Using 12 AWG or larger wire, connect the control transformer in the compressor starter panel to the proper terminals in the QUANTUM™LX control panel, as shown in the IOM on the compressor motor starter diagrams and the panel wiring diagrams. These wires are: black (1), white (2), and green (GND). (Copper ground only. Conduit ground is not acceptable.)

The main power wiring to the QUANTUM™LX panel (line and neutral) must be 12 AWG or larger. A separate ground wire is also required for each QUANTUM™LX panel and must also be at least a number 12 copper wire.

30. Connect the remaining control wires between the starter and the control panel, as shown in the IOM on the compressor motor starter diagrams and the panel wiring diagrams. These control wires are typically:

A. Compressor start	(18)
B. Compressor auxiliary	(20)
C. Current transformer	(3 and 4)
D. Oil pump start (if required)	(8)
E. Oil pump auxiliary (if required)	(19)

31. Connect the remaining package control wires, including options, to the control panel, as shown on the panel wiring diagrams in the manual S90-020 M.

32. Before applying power to the QUANTUM™LX control panel, make the following checks:

A. Check for loose connections or damage to the circuit boards or cables.

B. Check for wire clippings or metal drill filings on the circuit board or in the panel. Clean QUANTUM™LX control panel thoroughly before applying the control power.

33. Make sure that the circuit breakers (1CB and 2CB) in the QUANTUM™LX control panel are in the "OFF" position. Engage the electrical disconnect at the compressor starter.

34. Using a DIGITAL VOLTMETER, verify the AC line voltage in the QUANTUM™LX control panel. The AC line voltage should be between 100 VAC and 125 VAC or 185 VAC to 254 VAC.

35. Check for AC volts (in millivolts) between AC neutral (2) and AC ground (GND). If the millivolt reading is greater than 500 millivolts, pull the electrical disconnect at the motor starter and reverify ground and neutral circuits.

36. Turn circuit breakers 1CB and 2CB to the "ON" position.

37. POWER SUPPLY CALIBRATION - Measure the 5 volt DC power at the *Quantum™ LX* board using a calibrated Digital Volt Meter (DVM) at the location shown in the following pictorial. If the voltage read on the DVM is not between +5.10 and +5.20 VDC, then refer to the *Power Supply Identification, Adjustment and Replacement* section of S90-020 M.

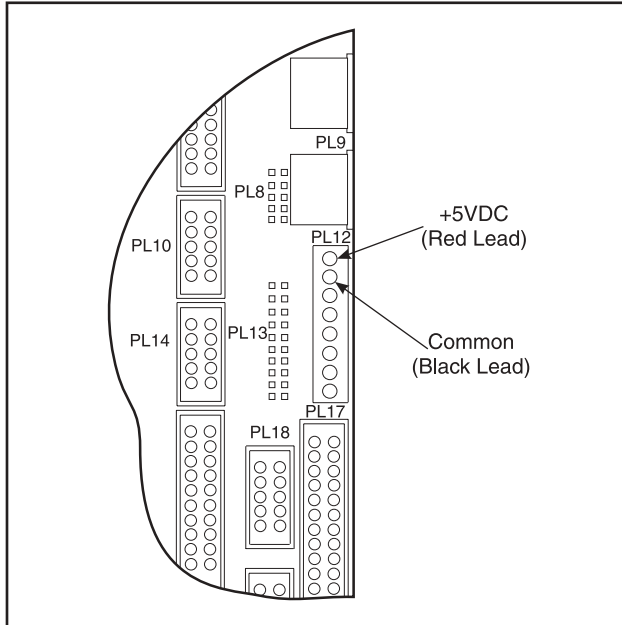

38. At this point you should have the operating display on the liquid crystal display panel.

39. Referring to the Operation manual (S90-020 O), ensure ensure that all setpoints have been properly entered.

40. To properly calibrate the temperature probes, a quality test thermometer is required. Go to the Temperature Calibration display and look at the first temperature to be calibrated.

41. Locate the associated temperature probe on the compressor package and pull the temperature probe from the well. Place the temperature probe in a container of water along with a quality test thermometer.

42. Wait for approximately two minutes and compare the thermometer reading with the temperature probe reading. Enter in the correction for temperature, if required.

43. Step to the next temperature to be calibrated and locate the associated temperature probe on the compressor package. Repeat the calibration procedure for each temperature probe.

44. After the temperature probe calibration is complete, reinsert the temperature probes into the wells and place the covers over the electrical boxes.

45. Open the suction and discharge stop valves. If applicable, open the side load stop valve, the economizer stop valve, and the liquid injection stop valve.

46. CHECK FOR LEAKS!

47. To calibrate the pressure transducers, a quality test gauge is required. Go to the Pressure Calibration display and step to the suction pressure setting.

48. Attach the test gauge to the suction pressure service valve behind the control panel. Read the pressure on the test gauge and compare this reading to the displayed value. Adjust the displayed value, if necessary.

49. Step to the discharge pressure setting on the Pressure Calibration display.

50. Repeat the calibration procedure.

51. Step to the oil pressure setting on the Pressure Calibration display.

52. Repeat the calibration procedure.

53. Step to the oil filter pressure setting on the Pressure Calibration display.

54. Attach the test gauge to the oil filter service valve. Compare the reading on the gauge with the displayed oil pressure reading. The oil filter pressure is the difference between displayed oil pressure and the gauge reading (should be zero when the compressor is not running).

55. To calibrate the slide valve, slide stop, and the motor current, refer to the Operation manual (S90-020 O).

56. This completes the *QUANTUM™ LX* retrofit instructions.

TRANSDUCER CONNECTION DIAGRAM FOR CONVERTING RWB II TO QUANTUM™LX CONTROL

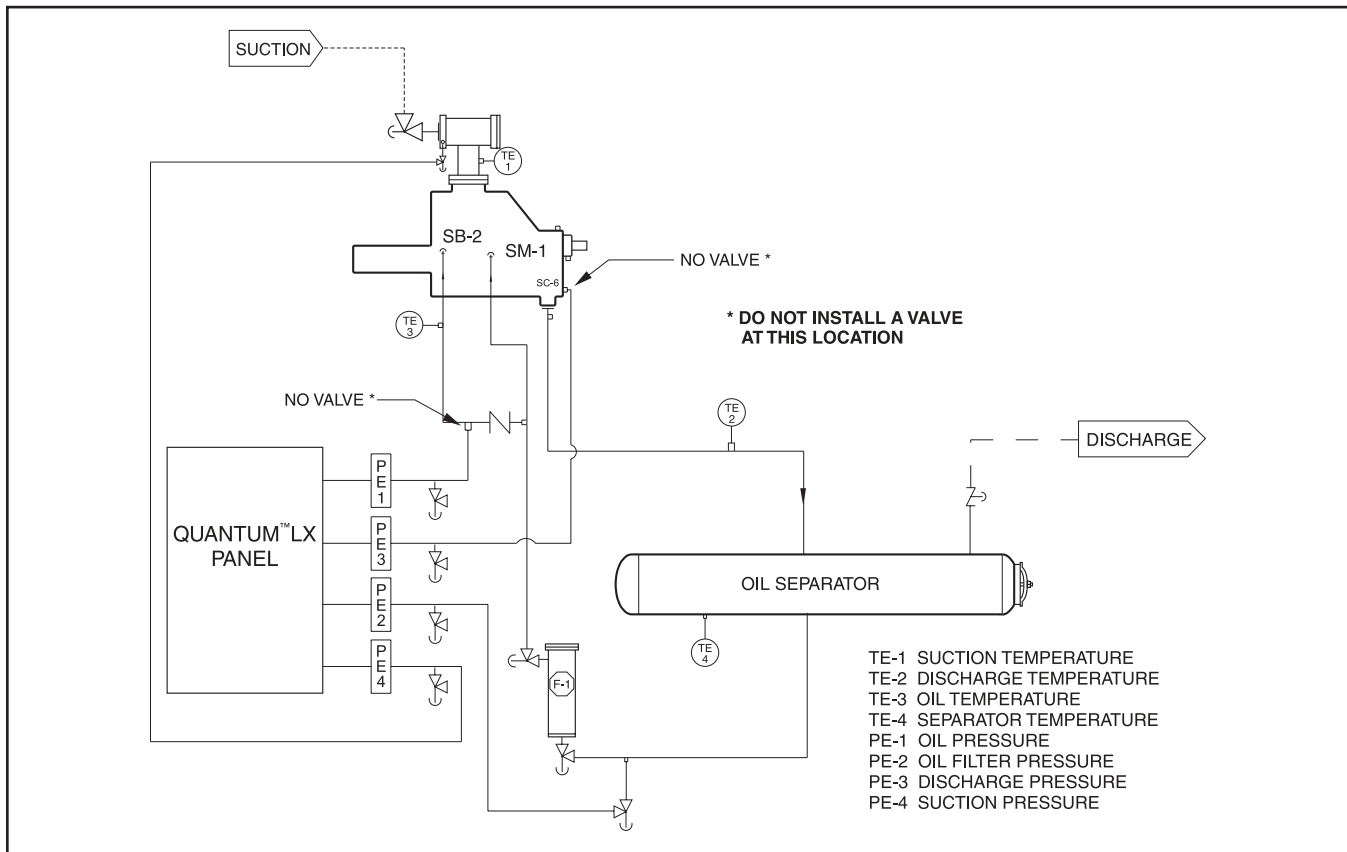

TRANSDUCER CONNECTION DIAGRAM FOR CONVERTING RWB AND OTHER MANUFACTURER'S UNITS TO QUANTUM™LX CONTROL

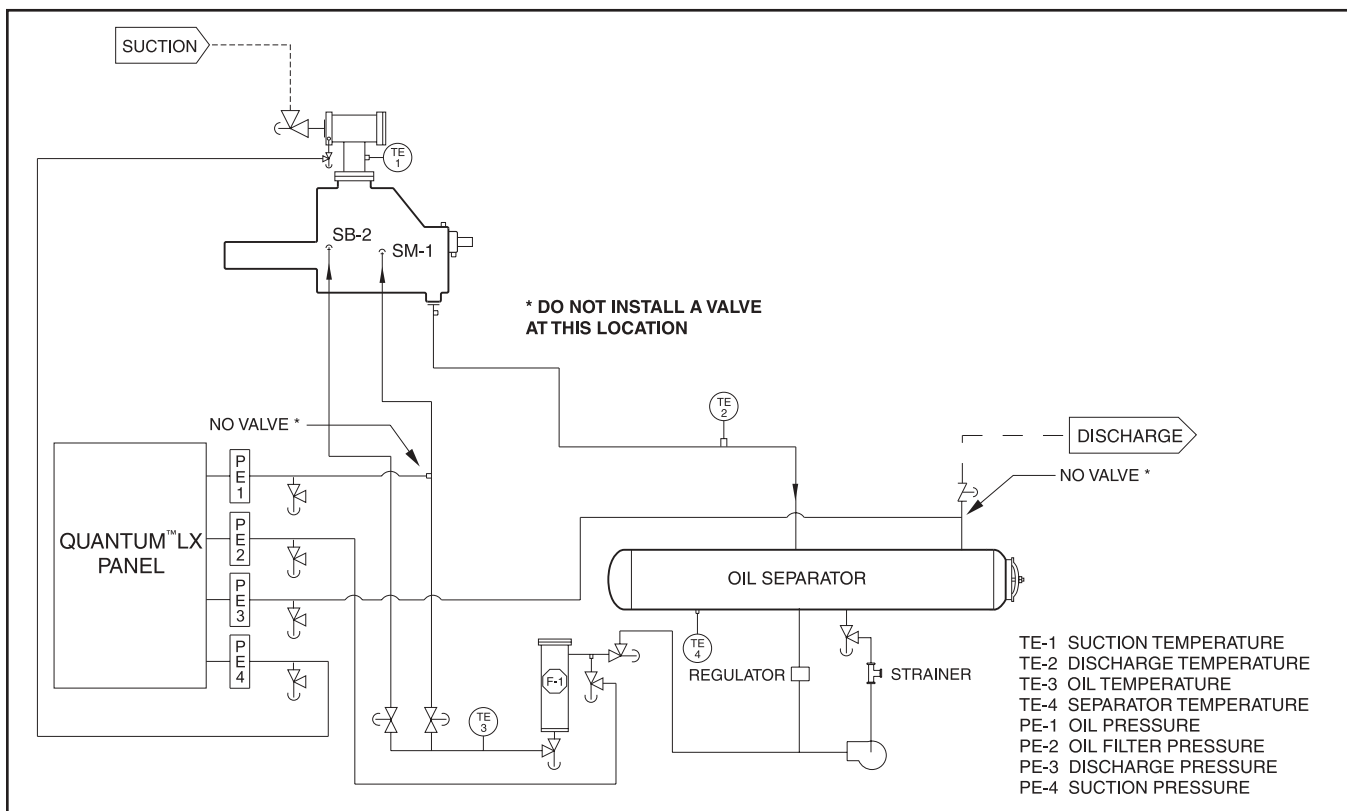

**PROPER INSTALLATION OF ELECTRONIC EQUIPMENT
IN AN INDUSTRIAL ENVIRONMENT**

In today's refrigeration plants, electronic controls have found their way into almost every aspect of refrigeration control. Electronic controls have brought to the industry more precise control, improved energy savings and operator conveniences. Electronic control devices have revolutionized the way refrigeration plants operate today.

The earlier relay systems were virtually immune to radio frequency interference (RFI), electromagnetic interference (EMI), and ground loop currents. Therefore installation and wiring were of little consequence and the wiring job consisted of hooking up the point-to-point wiring and sizing the wire properly. In an electronic system, improper installation will cause problems that outweigh the benefits of electronic control. Electronic equipment is susceptible to RFI, EMI, and ground loop currents which can cause equipment shutdowns, processor memory and program loss, erratic behavior, and false readings. Manufacturers of industrial electronic equipment take into consideration the effects of RFI, EMI, and ground loop currents and incorporate protection of the electronics in their designs. These manufacturers require that certain installation precautions be taken to protect the electronics from these effects. All electronic equipment must be viewed as sensitive instrumentation and therefore requires careful attention to installation procedures. These procedures are well known to instrument engineers, but are usually not followed by general electricians.

There are a few basics, that if followed, will result in a trouble-free installation. The National Electric Code (NEC) is a guideline for safe wiring practices, but it does not deal with procedures used for electronic control installation. **Use the following procedures for electronic equipment installation.** These procedures do not override any rules by the NEC, but are to be used in conjunction with the NEC code.

WIRE SIZING

Size supply wires one size larger than required for amperage draw to reduce instantaneous voltage dips caused by large loads such as heaters and contactors and solenoids. These sudden dips in voltage can cause the processor, whether it be a microprocessor, a computer, or a PLC to malfunction momentarily or cause a complete reset of the control system. If the wire is loaded to its maximum capacity, the voltage dips are much larger, and the potential of a malfunction is very high. If the wire is sized one size larger than required, the voltage dips are smaller than in a fully loaded supply wire, and the potential for malfunction is much lower. The NEC code book calls for specific wire sizes to be used based on current draw. An example of this would be to use #14 gauge wire for circuits up to 15 amp or #12 gauge wire for circuits of up to 20 amp. Therefore, when connecting the power feed circuit to an electronic industrial control, use #12 gauge wire for a maximum current draw of 15 amp and #10 wire for a maximum current draw of 20 amp. Use this rule of thumb to minimize voltage dips at the electronic control.

VOLTAGE SOURCE

Selecting the voltage source is extremely important for proper operation of electronic equipment in an industrial environment. Standard procedure for electronic instrumentation is to provide a "clean" separate source voltage in order to prevent EMI, from other equipment in the plant, from interfering with the operation of the electronic equipment. Connecting electronic equipment to a breaker panel (also known as lighting panels and fuse panels) subjects the electronic equipment to noise generated by other devices connected to the breaker panel. This noise is known as electromagnetic interference (EMI). EMI flows on the wires that are common to a circuit. EMI cannot travel easily through transformers and therefore can be isolated from selected circuits. **Use a control transformer to isolate the electronic control panel from other equipment in the plant that generate EMI. (Figure 1)**

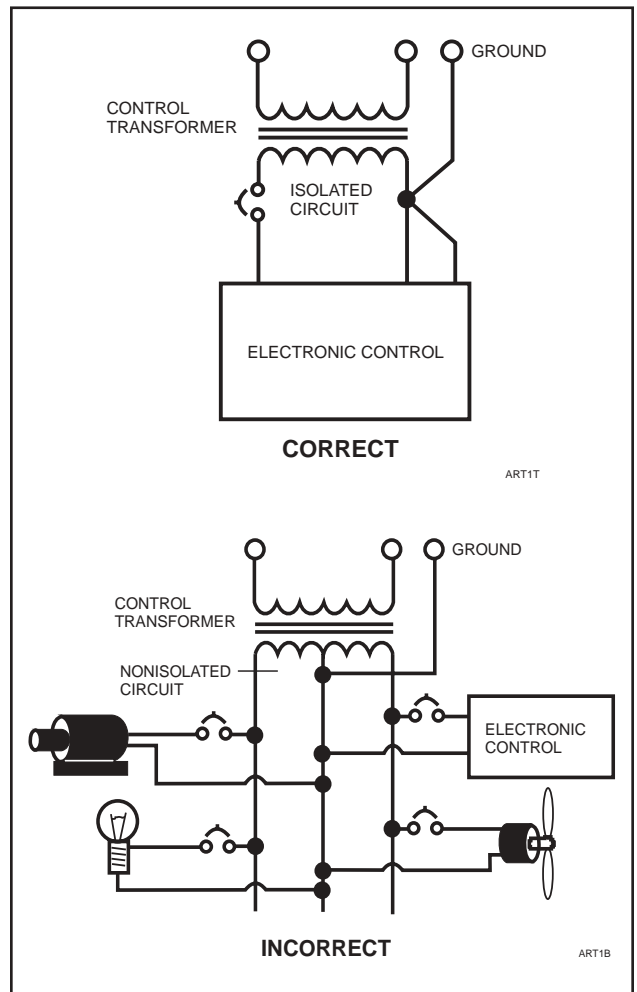

Figure 1

GROUNDING

Grounding is the most important factor for successful operation and is also the most overlooked. The NEC states that control equipment may be grounded by using the rigid conduit as a conductor. This worked for the earlier relay systems, but it is not acceptable for electronic control equipment. Conduit is made of steel and is a poor conductor relative to a copper wire. Electronic equipment reacts to very small currents and must have a good ground in order to operate properly; therefore, **copper grounds are required for proper operation.** **NOTE: aluminum may be used for the large three-phase ground wire.**

The ground wire must be sized the same size as the supply wires or one size smaller as a minimum. The three phase power brought into the plant must also have a ground wire, making a total of four wires. In many installations that are having electronic control problems, this essential wire is usually missing. A good ground circuit must be continuous from the plant source transformer to the electronic control panel for proper operation. (Figure 2) Driving a ground stake at the electronic control will cause additional problems since other equipment in the plant on the same circuits will ground themselves to the ground stake causing large ground flow at the electronic equipment.

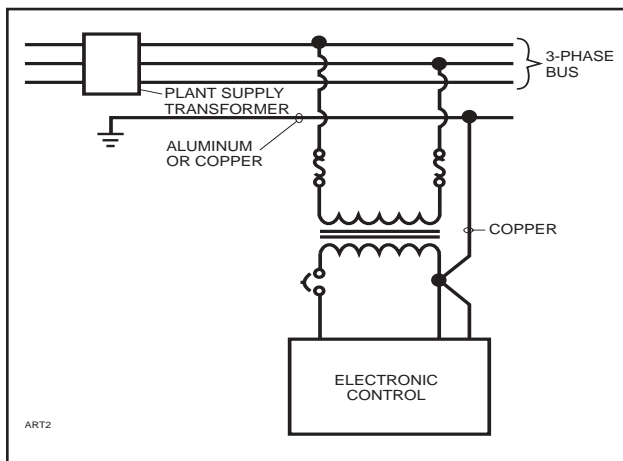

Figure 2

WIRING PRACTICES

Do not mix wires of different voltages in conduit. An example of this would be the installation of a screw compressor package. The motor voltage is 480 volts and the panel control power is 120 volts. **The 480 volt circuit must be run from the motor starter to the motor in its own conduit.** **The 120 volt circuit must be run from the motor starter control transformer to the control panel in its own separate conduit.** If the two circuits are run in the same conduit, transients on the 480 volt circuit will be inducted into the 120 volt circuit causing functional problems with the electronic control. Dividers must be used in wire way systems (conduit trays) to separate unlike voltages. The same rule applies for 120 volt wires and 220 volt wires. **Also, never run low voltage wires in the same conduit with 120 volt wires.** (Figure 3)

Never run any wires through an electronic control panel that do not relate to the function of the panel. Electronic control panels should never be used as a junction box. These wires may be carrying large transients that will interfere with the operation of the control. An extreme example of this would be to run the 480 volts from a motor starter through the control panel to the motor.

When running conduit to an electronic control panel, take notice of the access holes (knockouts) provided by the manufacturer. These holes are strategically placed so that the field wiring does not interfere with the electronics in the panel. **Never allow field wiring to come in close proximity with the controller boards since this will almost always cause problems.**

Do not drill a control panel to locate conduit connections. You are probably not entering the panel where the manufacturer would like you to since most manufacturers recommend or provide prepunched conduit connections. Drilling can cause metal chips to land in the electronics and create a short circuit. **If you must drill the panel, take the following precautions:** First cover the electronics with plastic and tape it to the board with masking or electrical tape. Second, place masking tape or duct tape on the inside of the panel where you are going to drill. The tape will catch most of the chips. Then clean all of the remaining chips from the panel before removing the protective plastic. It would be a good idea to call the manufacturer before drilling the panel to be sure you are entering the panel at the right place.

When routing conduit to the top of an electronic control panel, condensation must be taken into consideration. Water can condense in the conduit and run into the panel causing catastrophic failure. **Route the conduit to the sides or bottom of the panel and use a conduit drain.** If the conduit must be routed to the top of the panel, use a sealable conduit fitting which is poured with a sealer after the wires have been pulled, terminated and the control functions have been checked. **A conduit entering the top of the enclosure must have an "O" ring-type fitting between the conduit and the enclosure** so that if water gets on top of the enclosure it cannot run in between the conduit and the enclosure. This is extremely important in outdoor applications.

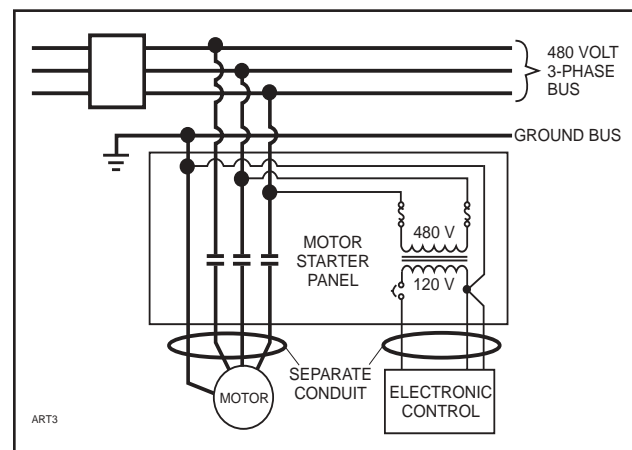

Figure 3

Never add relays, starters, timers, transformers, etc. inside an electronic control panel without first contacting the manufacturer. Contact arcing and EMI emitted from these devices can interfere with the electronics. Relays and timers are routinely added to electronic control panels by the manufacturer, but the manufacturer knows the acceptable device types and proper placement in the panel that will keep interference to a minimum. If you need to add these devices contact the manufacturer for the proper device types and placement.

Never run refrigerant tubing inside an electronic control panel. If the refrigerant is ammonia, a leak will totally destroy the electronics.

If the electronic control panel has a starter built into the same panel, be sure to run the higher voltage wires where indicated by the manufacturer. EMI from the wires can interfere with the electronics if run too close to the circuitry.

Never daisy-chain or parallel-connect power or ground wires to electronic control panels. Each electronic control panel must have its own supply wires back to the power source. Multiple electronic control panels on the same power wires create current surges in the supply wires which can cause controller malfunctions. Daisy-chaining ground wires allows ground loop currents to flow between electronic control panels which also causes malfunctions. (Figure 4)

It is very important to read the installation instructions thoroughly before beginning the project. Make sure you have drawings and instructions with your equipment. If not, call the manufacturer and have them send you the proper instructions. Every manufacturer of electronic equipment should have a knowledgeable staff, willing to answer your questions or fax additional information. Following correct wiring procedures will ensure proper installation of your electronic equipment.

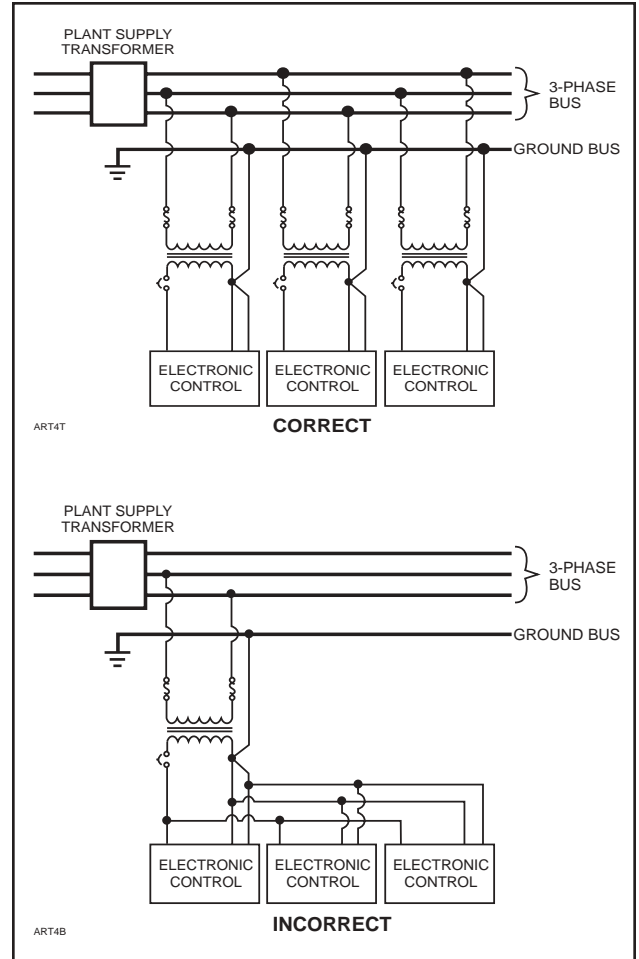

Figure 4



YORK Refrigeration Systems
100 CV Avenue • P.O. Box 997 • Waynesboro, Pennsylvania USA 17268-0997
Phone: 717-762-2121 • FAX: 717-762-8624 • www.frickcold.com

