

E-Link Gateway

Installation Instructions

Part No. 24-10404-9, Rev. D
Issued November 2, 2011
Supersedes April 29, 2011

Refer to the [QuickLIT Web site](#) for the most up-to-date version of this document.

Applications

The E-Link Gateway provides Johnson Controls® and YORK® mechanical equipment, such as chillers and rooftop units, with Building Automation System (BAS) networking connectivity. It is designed with three active serial ports: Port 1 and Port 4 are used for BAS networking, Port 2 is reserved for connecting to the equipment, and Port 3 provides access for auxiliary monitoring and control.

To simplify the installation and setup, the E-Link Gateway comes pre-configured with a series of chiller and rooftop equipment profiles that you can choose by selecting the correct DIP switch settings.

Several E-Link Gateway models are available for connection to various types of input voltage and equipment. For chillers using the OptiView™ or Latitude Micro Panel, the E-Link Gateway consists of a single circuit board attached to four studs inside the Micro Panel, using the accessory mounting kit. The panel supplies 12 VDC input power, eliminating the need for an external power supply.

For chillers using the IPU-II based Micro Panel, the E-Link Gateway is installed inside the Micro Panel and requires an additional transformer to supply power to the E-Link Gateway. The transformer is included in the E-Link IPU-II Installation Kit. (This kit is not available in Europe. Use E-Link Gateway YK-ELNKE00-0.)

For other types of chillers, the E-Link Gateway is packaged in its own enclosure. In addition to the E-Link Gateway circuit board, a transformer is included inside the enclosure that converts a 120- or 240-volt input to 24 VAC power.

North American Emissions Compliance

United States

This equipment has been tested and found to comply with the limits for a Class A digital device pursuant to Part 15 of the FCC Rules. These limits are designed to provide reasonable protection against harmful interference when this equipment is operated in a commercial environment. This equipment generates, uses, and can radiate radio frequency energy and, if not installed and used in accordance with the instruction manual, may cause harmful interference to radio communications. Operation of this equipment in a residential area is likely to cause harmful interference, in which case the user will be required to correct the interference at his/her own expense.

Canada

This Class (A) digital apparatus meets all the requirements of the Canadian Interference-Causing Equipment Regulations.

Cet appareil numérique de la Classe (A) respecte toutes les exigences du Règlement sur le matériel brouilleur du Canada.

Installation

The E-Link Gateway is supplied as a circuit board that can be installed directly into the equipment's enclosure, or can be supplied pre-mounted in an enclosure ready for line voltage. Accessory mounting kits are used to mount the E-link Gateway directly into OptiView Latitude, and IPU-II based Micro Panels.

IMPORTANT: Do not install the E-Link Gateway directly into an equipment's enclosure without the use of an approved installation kit.

IMPORTANT: The E-Link Gateway is intended to provide an input to equipment under normal operating conditions. Use this E-Link Gateway only as an operating control. Where failure or malfunction of the E-Link Gateway could lead to personal injury or property damage to the controlled equipment or other property, additional precautions must be designed into the control system. Incorporate and maintain other devices, such as supervisory or alarm systems or safety or limit controls, intended to warn of or protect against failure or malfunction of the E-Link Gateway.

Table 1: YORK Chiller Models (Current Production)

Board Number ¹	Language (Native)	Chiller Model
031-02550	BACnet®, Modbus®, YORK Talk 2, 4,800 bits per second (bps)	YCWL, YCUL, YCAL, YLAA, YCRL, YLPA
031-01095	YORK Talk 2, 4,800 bps	YCAS, YCWS, YCRS
031-02478	YORK Talk 2, 4,800 bps	YCAV, YCIV, YVAA
031-01065	YORK Talk 2, 1,200 bps	YIA, YPC, YG, YB
031-01730	YORK Talk 3	YN, OM RETROFITS, CR
031-02430	YORK Talk 3	YK, YT, YS, YR, YST, YD, YMC ²
331-02496	BACnet®	YPAL
YORK-003	Modbus RTU	YEWS-D1, YEAS, YGAS ²

1. Installing technician must verify board number in unit prior to installation.
2. Software edition of YEWS-D1 (RHSYEWSD1) V1.08 or later), YEAS (RHMASB V1.06 or later), YGAS (RHMYGAS V1.03 or later) are supported.

Table 2: E-Link Gateway Product Code Numbers

Description	Product Code Numbers
E-Link with Serial Outputs (BACnet Master-Slave/Token-Passing [MS/TP], Modbus Remote Terminal Unit [RTU], and N2)	YK-ELNK100-0
E-Link with LONWORKS® as an Output	YK-ELNK101-0
E-Link with Serial Outputs in Enclosure	YK-ELNKE00-0
E-Link with LONWORKS Output in Enclosure	YK-ELNKE01-0
E-Link OptiView/Latitude Panel Installation Kit	YK-ELNKOLK-0
E-Link IPU-II Panel Installation Kit (not available in Europe)	YK-ELNKSTK-0

Mounting



WARNING: Risk of Electric Shock.

Disconnect or isolate all power supplies before making electrical connections. More than one disconnect or isolation may be required to completely de-energize equipment. Contact with components carrying hazardous voltage can cause electric shock and may result in severe personal injury or death.

OptiView Panel Installation

1. Attach the E-Link Gateway board to the studs provided inside the chiller enclosure (Figure 1 or Figure 2), using the four screws and washers provided in the OptiView/Latitude installation kit.
2. Connect the communications cable (included with the kit) from Port 2B on the E-Link Gateway to J2 on the OptiView Micro Panel. Ensure that wires are connected according to Table 3.
3. Check for stray wire strands, which could cause short circuits, and ensure all components are secure.
4. Connect the BAS network to Port 1 (if the protocols are transported by RS-485) or Port 4 (if the BAS network is LONWORKS).

Note: For RS-485 2-wire operation, connect a 100 ohm 1 W resistor between COM and the E-Link Gateway's TB5 COM (see Figure 24).

5. Ensure jumper JP27 is set for RS-232 (see Figure 20).
6. Connect the power harness (included with the kit) from J2 on the E-Link Gateway to J21 on the OptiView Micro Panel (see Figure 20).

The E-Link Gateway is now ready to be configured using Quick Start; see the [Commissioning a Standard Application](#) section in this document.

Table 3: OptiView Wiring - E-Link Port 2B

E-Link Port 2B	OptiView Port	Wire Color
RX	GTX	Black
TX	GRX	Red
REF	N/A	Shield/Drain

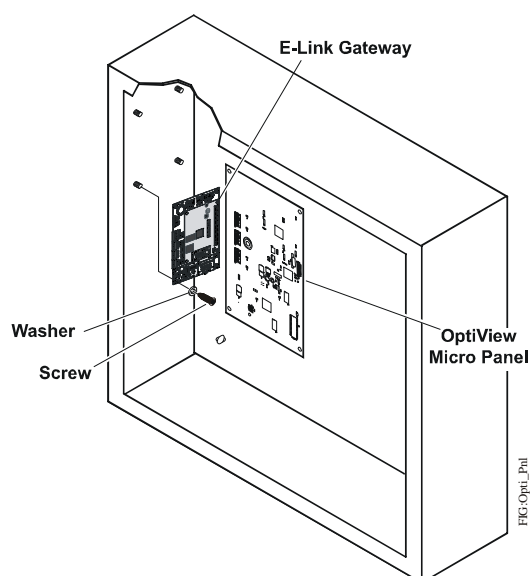

Figure 1: OptiView Micro Panel Connected to E-Link Gateway

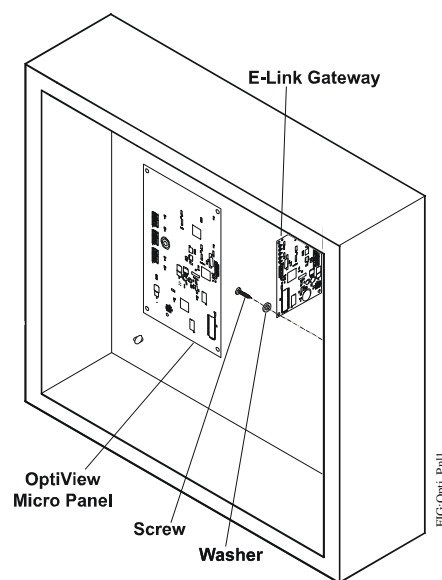

Figure 2: OptiView Micro Panel for YMC² Connected to E-Link Gateway

Table 4: BAS Wiring - E-Link Port 1

E-Link Port 1	BAS	Wire Color
+	+	White
-	-	Blue
REF	REF	Black

IPU-II Panel Installation
(Installation Kit Not Available in Europe)

1. Attach the E-Link Gateway board to the panel in the upper right side of the enclosure using the four expansion screws and nuts provided in the IPU-II Panel Installation Kit (see Figure 3).
2. Attach the 24 VAC transformer to the panel to the left of the E-Link board using two screws (see Figure 3).
3. Connect the communications cable (included with the kit) between the E-Link board and IPU-II Micro board.

4. Connect the transformer to the terminal block.
5. Connect the transformer to E-Link. Secure the wiring with tie-wraps.
6. Connect the resistor if the RS-485 2-wire operation is required.
7. Connect the communications cable shielded ground to the ground screw.

The E-Link Gateway is now ready to be configured using Quick Start; see the [Commissioning a Standard Application](#) section in this document.

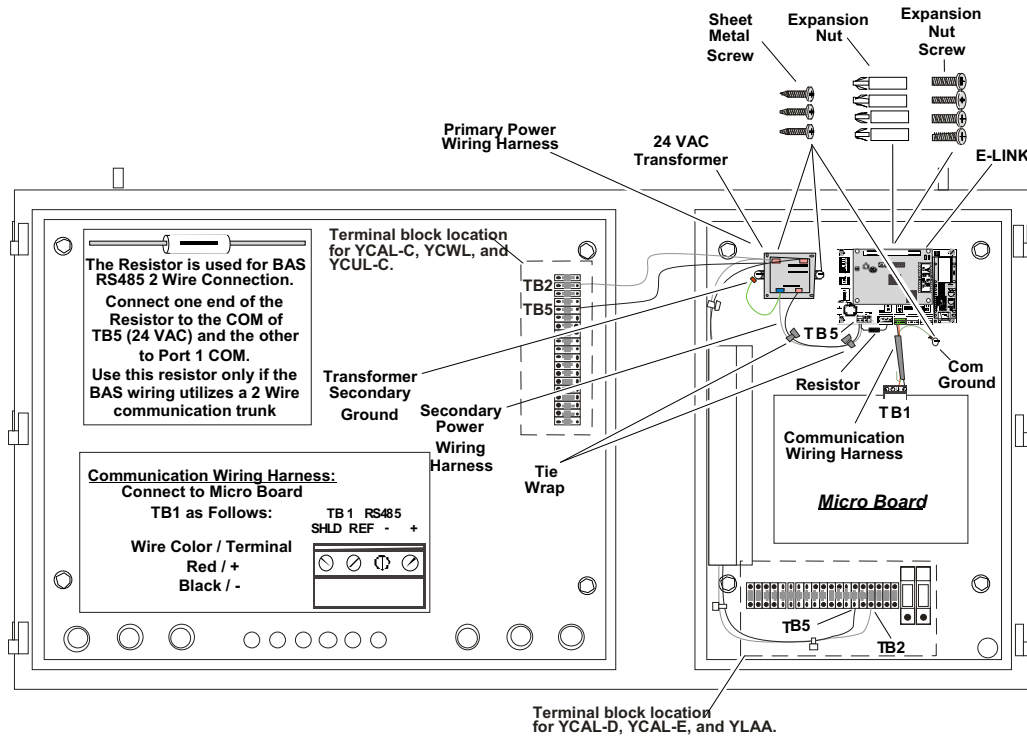

Figure 3: IPU-II Panel Installation (Installation Kit Not Available in Europe)

Other Chiller Panel Installation

For all other applications, the E-Link Gateway includes an optional enclosure. The optional enclosure does not include communication cables due to the variety of types and lengths that may be required.

IMPORTANT: Never install the E-Link Gateway outside the confines of a building unless within another enclosure rated IP 65/NEMA 4x or higher.

The E-Link Gateway can be mounted as a stand-alone enclosure either on the outside surface of the chiller Micro Panel (close coupled), or on a smooth surface within close proximity of the chiller panel enclosure.

For mounting on a Micro Panel, the line voltage power is supplied by a power source in the Micro Panel.

IMPORTANT: Make sure that the cover is securely fastened to the enclosure and the internal ground wire is attached before placing the Gateway in operation. These steps help to minimize Radio Frequency Interference (RFI) from being generated and picked up.

Mounting on a Micro Panel



WARNING: Risk of Electric Shock.

Disconnect or isolate all power supplies before making electrical connections. More than one disconnect or isolation may be required to completely de-energize equipment. Contact with components carrying hazardous voltage can cause electric shock and may result in severe personal injury or death.

IMPORTANT: When attaching the E-Link Gateway to a Micro Panel, ensure the E-Link Gateway does not impede access to other components.

To mount the E-Link Gateway on a Micro Panel:

1. Disconnect power to the chiller Micro Panel.
2. Make sure the E-link Gateway enclosure fits properly and that no obstructions, such as internal boards, switches, or external conduit, prevent mounting or servicing of the panel. See Figure 4 for examples of good mounting locations.

3. Locate and remove the two plastic caps in the bottom of the E-Link Gateway enclosure.
4. Mark an appropriate place on the enclosure for a matching set of knock out holes. Mark and drill, or punch, two holes in the Micro Panel.
5. Using two bulkhead pipe couplers, attach the E-Link Gateway enclosure to the Micro Panel.
6. Complete wiring as described in the Applying Power section in this document.

IMPORTANT: Be careful not to damage the E-link Gateway or Micro Panel's circuit boards during the installation. Protect all circuit boards from metal chips, which may cause short circuits if left on the boards at startup.

Note: Use of bulkhead pipe couplers provides sufficient clearance to allow removal of the E-Link Gateway cover.

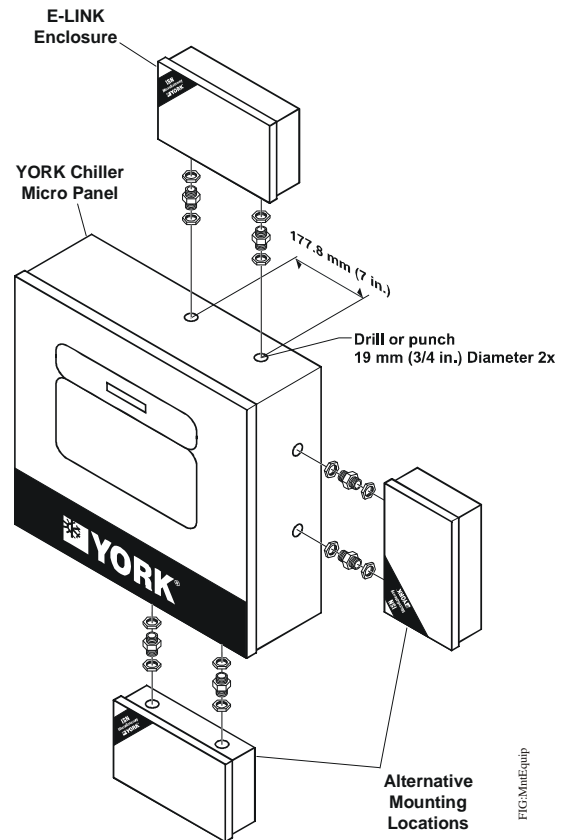

Figure 4: Mounting on the Equipment

Wall Mounting

To mount the E-Link Gateway on a wall:

IMPORTANT: When wall mounting, make sure there is no interference with other components in the near vicinity. Use appropriate conduit to connect the power and communications wiring.

1. Check for proper clearances for the necessary electrical and communications cable runs.
2. Ensure that power and communications wiring is in compliance with all local, national, and regional codes, and customer requirements.
3. Select a suitable location and mark the anchor points. Ensure that the enclosure is level. See Figure 5 for an example.
4. Drill the appropriate holes in accordance with the type of wall anchor used.
5. Install the enclosure on the wall.

IMPORTANT: Be careful not to damage the circuit boards during installation.

6. Check that the mounting is secure and the wiring connections are correct and tight. Check that no loose wire strands or other metal objects that could cause a short circuit are on the circuit board.
7. Complete wiring as described in the [Applying Power](#) section.

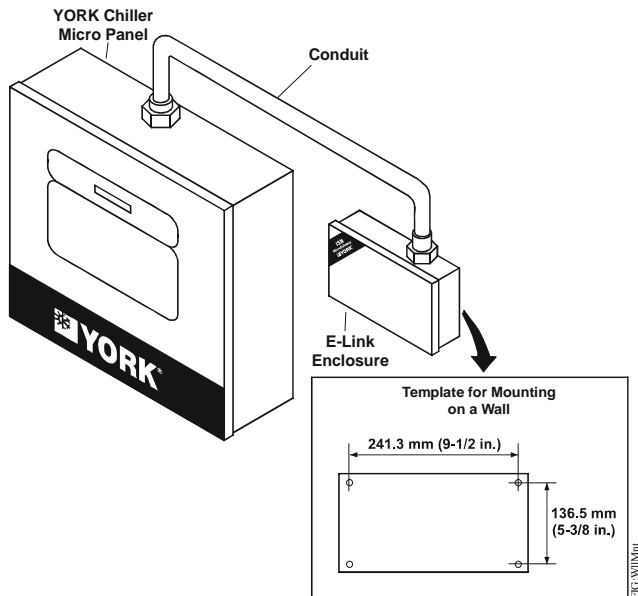

Figure 5: Wall Mounting

Applying Power

When using an enclosure type of E-Link Gateway, power can be supplied from either a separate power supply or the main terminal strip in the chiller panel. Locate the power source within 0.9 m (3 ft) of the E-Link Gateway, and protect it with a suitable fuse or circuit breaker. Ensure the power is supplied from a dedicated source and not controlled by a programmed switch.

If the enclosure is mounted on a wall, the wiring from the power source to the E-Link Gateway must always run in a suitable conduit. To obtain the best Electromagnetic Interference (EMI) and Electromagnetic Compatibility (EMC) performance, ensure that the conduit is bonded to the metal of both enclosures. Scraping the paint around the knockouts usually helps provide a better electrical connection between the joining parts.



WARNING: Risk of Electric Shock.

Disconnect or isolate all power supplies before making electrical connections. More than one disconnect or isolation may be required to completely de-energize equipment. Contact with components carrying hazardous voltage can cause electric shock and may result in severe personal injury or death.



CAUTION: Risk of Property Damage.

Do not apply power to the system before checking all wiring connections. Short circuited or improperly connected wires may result in permanent damage to the equipment.

1. Connect a 1.29-1.02 mm (16-18 AWG) wire from a reliable ground reference to the E-Link Gateway's incoming power ground lug. Do not remove the existing wire that connects the ground lug to the enclosure cover.
2. On 120 VAC applications, connect the Hot wire to TB2 and the Neutral wire to TB1. Connect the ground wire to a ground lug.

On 240 VAC applications, connect the Hot wire to TB3 and the Neutral wire to TB1. Connect the ground wire to a ground lug.

IMPORTANT: Use copper conductors only.

Make all wiring connections in accordance with local, national, and regional regulations. Do not exceed the E-Link Gateway's electrical ratings.

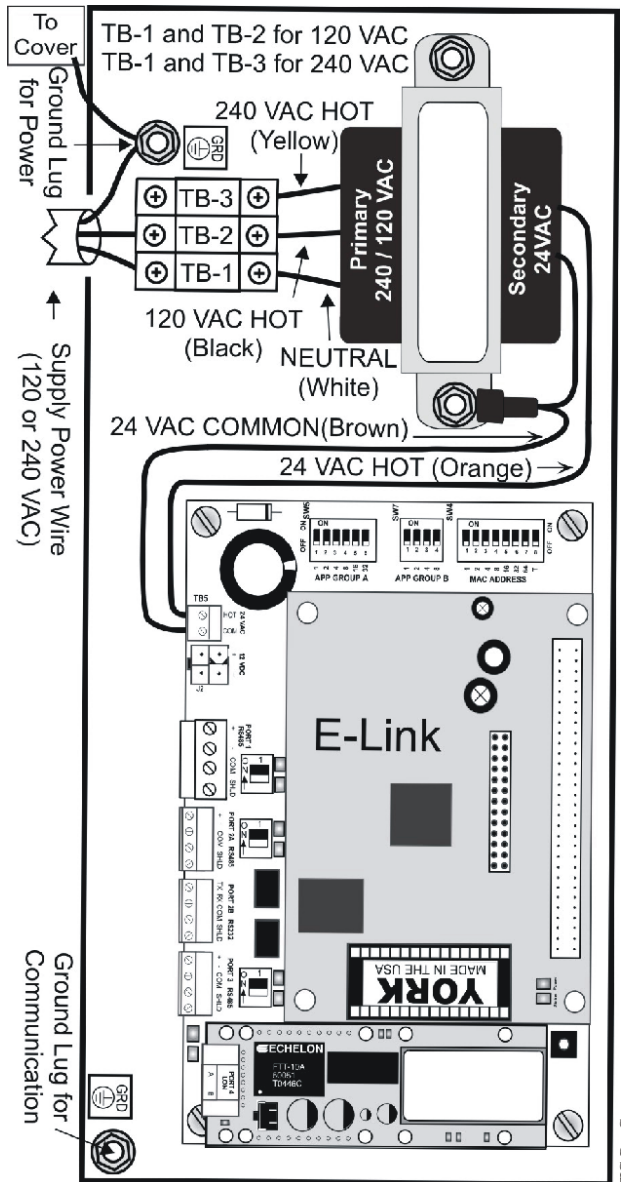

Figure 6: Power Connection Shown as 120 VAC

Commissioning a Standard Application

Once the E-Link Gateway has been mechanically and electrically installed (that is, it has been located in its enclosure, wired, and terminated appropriately), it may be Quick Commissioned.

1. Apply power and verify that the red power Light-Emitting Diode (LED) on the IPU-II board is on. Make sure the T-switch is set to OFF, and then set the required Media Access Control (MAC) address. Set the MAC address in accordance with the system integrator to ensure that a unique address is used. If any non-standard setup is required, refer to the *E-Link Commissioning and Troubleshooting Guide (LIT-12011238)* for more details.

Table 5: Allowable MAC Addresses

Protocol	Max Allowable Switch Settable MAC Addresses
BACnet MS/TP	1 – 127
N2	1 – 127
Modbus RTU	1 – 127

2. Based on the equipment to be integrated (see Table 8) and the required BAS output protocol (see Table 9), select the appropriate settings on GROUP A and GROUP B switches. For equipment points lists, refer to the *Johnson Controls Portal (Products and Services>Delivery>Products/Service Field Support>Equipment Integration>YORK Equipment Data Maps)*.
3. Press, hold a few seconds, then release the push button shown in Figure 11. The status LED flashes quickly. After the E-Link Gateway re-initializes, the commissioning is complete.
4. When commissioning a LONWORKS BAS output protocol, disconnect the BAS network and cycle the power on the E-Link Gateway to activate the Quick Start and the LONWORKS FTT10 ProtoCessor. The ProtoCessor does not recognize the push button as a trigger to reset and load the correct conversion file. Wait a minimum of 10 minutes before reconnecting the BAS network.
5. Check the E-Link Gateway's LEDs. First, check the STATUS LED; if the E-Link Gateway has no errors, it flashes continuously (1/2 second on, 1/2 second off). If the LED is not flashing continuously, see Table 6 for possible reasons.

- Place the equipment in remote operating mode to accept commands from the E-Link Gateway. Refer to the equipment installation literature for the proper configuration settings.

Table 6: LED Status indication

Flash Rate	Status LED Indication
LED Off	No database configuration is loaded, or no input power is present.
1 Flash	Terminal mode has been invoked (Switch T is on).
2 Flashes	An equipment to E-Link communications error has occurred.
3 Flashes	A Quick Start has a configuration error.
LED On	No errors with custom/field modified application.
Flashing Continuously	No errors with factory standard application.

For all chillers that use the YORK Talk protocols, check that the Port 2 communication LEDs, Red (TX) and Green (RX), are flashing. This scenario indicates that the chiller panel is being polled and is responding. See Figure for the location of Port 2 communication LEDs.

What You Should Know before Using Quick Starts

The E-Link is designed to use a set of predefined data maps to associate equipment data with a set of fixed BAS network variables. You are not able to make any field changes to these data maps; attempting to do so results in the automatic reversal of any edits that you may have made. For any field patches, refer to your local *FSC (Field Support Center)* for guidance.

The data maps used by the E-Link Gateway are based on a collection of version controlled equipment point lists, which are supplied by the equipment business for the purpose of integrating equipment into BAS networks. Unless noted otherwise, the equipment's data is available in these supported BAS protocols: BACnet MS/TP, N2, LONWORKS, and Modbus RTU.

The first release of the E-Link was positioned to provide the equivalent functionality as offered by the YORK MicroGateway. That release requires you to reference point lists which are version J or earlier. All subsequent E-link releases use point lists version K or later.

Table 7: E-Link Releases

Firmware/Database Revision	Point Lists
SSM4567 JCF0003BL.BIN	J and earlier only
SSM4567 JCF0008BL.BIN	J and earlier, or K

Quick Starts 1 through 16 all use the J version point lists, whereas Quick Starts 17 through 33 use the K version. The primary difference between the two categories is that Quick Starts 1 through 16 have limited network visible points. In this case, the available points are those which were originally available at the time when the MicroGateway was first released.

Quick Starts 17 and higher offer a much richer equipment point compliment that is more reflective of what the equipment currently makes available today. These Quick Starts also create profiles that use more descriptive BACnet point names, use engineering units, and follow the BACnet Testing Laboratories™ (BTL) guidelines for compliance as a B-ASC controller.

In most cases, using a Quick Start that corresponds to the equipment being integrated is sufficient to configure the E-Link Gateway for operating on the BAS network; however, in some circumstances, you will be required to provide further customizing by connecting a laptop computer onto Port 3 and then accessing the User Reports (refer to the *E-Link Gateway Commissioning and Troubleshooting Technical Bulletin [LIT-12011238]* for more information).

Table 8: Equipment Quick Start Selections

Switch Settings	APP Group Switch A						Equipment Profile Quick Starts	
	32	16	8	4	2	1	Functionality	
1 ¹	0	0	0	0	0	1	YK with SSS Imperial	(YORK Talk-III) J version points
2	0	0	0	0	1	0	YK with VSD Imperial	(YORK Talk-III) J version points
3 ¹	0	0	0	0	1	1	YT with SSS Imperial	(YORK Talk-III) J version points
4	0	0	0	1	0	0	YT with VSD Imperial	(YORK Talk-III) J version points
5 ¹	0	0	0	1	0	1	YS / YR with SSS Imperial	(YORK Talk-III) J version points
6 ¹	0	0	0	1	1	0	YK with SSS Metric	(YORK Talk-III) J version points
7	0	0	0	1	1	1	YK with VSD Metric	(YORK Talk-III) J version points
8 ¹	0	0	1	0	0	0	YT with SSS Metric	(YORK Talk-III) J version points
9	0	0	1	0	0	1	YT with VSD Metric	(YORK Talk-III) J version points
10 ¹	0	0	1	0	1	0	YS / YR with SSS Metric	(YORK Talk-III) J version points
11	0	0	1	0	1	1	YORK Talk II, 1200, 1 Section	(YORK Talk-II) J version points
12	0	0	1	1	0	0	YORK Talk II, 4800, 1 Section	(YORK Talk-II) J version points
13 ²	0	0	1	1	0	1	YORK Talk II, 4800, 2 Sections	(YORK Talk-II) J version points
14	0	0	1	1	1	0	YD Imperial	(YORK Talk-III) J version points
15	0	0	1	1	1	1	YD Metric	(YORK Talk-III) J version points
16	0	1	0	0	0	0	ECO2 / YPAL / S100	(BACnet MS/TP via an IPU-I)
17	0	1	0	0	0	1	YK with SSS Imperial	(YORK Talk-III) K version points
18	0	1	0	0	1	0	YK with VSD Imperial	(YORK Talk-III) K version points
19	0	1	0	0	1	1	YT with SSS Imperial	(YORK Talk-III) K version points
20	0	1	0	1	0	0	YT with VSD Imperial	(YORK Talk-III) K version points
21	0	1	0	1	0	1	YS / YR with SSS Imperial	(YORK Talk-III) K version points
22	0	1	0	1	1	0	YK with SSS Metric	(YORK Talk-III) K version points
23	0	1	0	1	1	1	YK with VSD Metric	(YORK Talk-III) K version points
24	0	1	1	0	0	0	YT with SSS Metric	(YORK Talk-III) K version points
25	0	1	1	0	0	1	YT with VSD Metric	(YORK Talk-III) K version points
26	0	1	1	0	1	0	YS / YR with SSS Metric	(YORK Talk-III) K version points
27	0	1	1	0	1	1	YST Imperial	(YORK Talk-III) K version points
28	0	1	1	1	0	0	YIA Imperial	(YORK Talk-III) K version points
29	0	1	1	1	0	1	YST Metric	(YORK Talk-III) K version points
30	0	1	1	1	1	0	YIA Metric	(YORK Talk-III) K version points
31	0	1	1	1	1	1	YEWS-D1/YEAS/YGAS	(Modbus native)
32	1	0	0	0	0	0	YD Imperial	(YORK Talk-III) K version points
33	1	0	0	0	0	1	YD Metric	(YORK Talk-III) K version points
34	1	0	0	0	1	0	YMC2 Imperial	(YORK Talk-III) K version points
35	1	0	0	0	1	1	YMC2 Metric	(YORK Talk-III) K version points
63	1	1	1	1	1	1	Reserved for Field adjustments	

1. A Quick Start that references a Solid State Starter (SSS) is also applicable to a mechanical starter.
2. Two sections are required for equipment equipped with three or more compressors, or two systems.

Table 9: BAS Output Protocol Quick Start Selections

Switch Settings	APP Group Switch B				Output Protocol Quick Starts		
	8	4	2	1	Port 1	Port 3	Port 4
0 ¹	0	0	0	0	MS/TP, AUTO, N, 8, 1	Modbus, 19,200, N, 8, 1	Terminal
1 ^{2, 5}	0	0	0	1	MS/TP, AUTO, N, 8, 1	Modbus, 19,200, N, 8, 1	Terminal
2 ^{2, 5}	0	0	1	0	MS/TP, AUTO, N, 8, 1	Modbus, 19,200, N, 8, 2	Terminal
3 ^{2, 5}	0	0	1	1	MS/TP, AUTO, N, 8, 1	N2, 9,600, N, 8, 1	Terminal
4 ^{2, 5}	0	1	0	0	N2, 9,600, N, 8, 1	MS/TP, 38,400, N, 8, 1	Terminal
5 ^{2, 5}	0	1	0	1	Modbus, 19,200, N, 8, 1	MS/TP, 38,400, N, 8, 1	Terminal
6 ^{2, 5}	0	1	1	0	Modbus, 19,200, N, 8, 2	MS/TP, 38,400, N, 8, 1	Terminal
7 ^{2, 5}	0	1	1	1	Modbus, 9,600, E, 8, 1	MS/TP, 38,400, N, 8, 1	Terminal
8 ^{2, 5}	1	0	0	0	Modbus, 9,600, N, 8, 1	MS/TP, 38,400, N, 8, 1	Terminal
9 ^{3, 5, 6}	1	0	0	1	N2, 9,600, N, 8, 1	Modbus, 19,200, N, 8, 1	LONWORKS – Pass through
10 ^{4, 5, 6}	1	0	1	0	N2, 9,600, N, 8, 1	Modbus, 19,200, N, 8, 1	LONWORKS – Conversion
11 ^{3, 5}	1	0	1	1	Modbus, 19,200, N, 8, 2	N2, 9,600, N, 8, 1	LONWORKS – Pass through
12 ^{4, 5}	1	1	0	0	Modbus, 19,200, N, 8, 2	N2, 9,600, N, 8, 1	LONWORKS – Conversion
13 ^{2, 5}	1	1	0	1	Modbus, 9,600, E, 8, 1	Modbus, 19,200, N, 8, 2	Terminal
14 ^{2, 5}	1	1	1	0	MS/TP, 38,400, N, 8, 1	N2, 9,600, N, 8, 1	Terminal
15 ⁷	1	1	1	1	Reserved	Reserved	Terminal

1. When making edits to User Report 4 (Port Configuration), Group Application Switch B **must** be set to zero. This setting ensures that the edits are stored. Otherwise, the edits are overwritten to the default values assigned to the particular Group Switch B setting the next time E-Link is reset, or power is cycled. Edits made in any other User Reports do not require alterations to either bank of Group Application switches. For standard set-up, not requiring modifications via User Report 4, use application switch B, settings 1 to 14.
2. The Terminal setting on Port 4 is restricted for factory use only.
To comply with the LONMARK® specification, all data transmitted on the LONWORKS network must be expressed in SI units (metric units). The LONWORKS ProtoCessor performs no unit conversions; it assumes that the data supplied is already correctly expressed.
3. Use Quick Start 9 and 11 if the equipment is supplying the data in SI units (the E-Link is not required to perform any conversions, so it operates in pass-through mode).
4. Use Quick Start 10 and 12 if the equipment is supplying the data in Imperial units and the E-Link is required to convert these units into SI.
5. Setting Switch T = ON, on the MAC address, forces TERMINAL mode of Port 3, at 57,600 baud, N, 8, 1. This setting is only required to debug the E-Link Gateway's operation, or access the User Reports.
6. Select Quick Starts 9 and 10 when connecting the E-Link Gateway to an ECO2 unit.
7. Quick Starts 15 on APP Group B, and 63 on APP Group A, are reserved for field adjustments.

Wiring

**WARNING: Risk of Electric Shock.**

Disconnect or isolate all power supplies before making electrical connections. More than one disconnect or isolation may be required to completely de-energize equipment. Contact with components carrying hazardous voltage can cause electric shock and may result in severe personal injury or death.

**CAUTION: Risk of Property Damage.**

Do not apply power to the system before checking all wiring connections. Short circuited or improperly connected wires may result in permanent damage to the equipment.

IMPORTANT: Make all wiring connections in accordance with local, national, and regional regulations.

Install the wiring so it does not cause a hazard, and is protected against electrical and mechanical damage.

Power

The E-Link Gateway circuit board is powered from either a 12 VDC, or a 24 VAC, Class 2 power source. When used with an OptiView chiller, the Micro Panel supplies low-voltage power via a power harness supplied by the OptiView/Latitude installation kit. If the E-Link Gateway circuit board is installed in its own enclosure, a transformer is included in the enclosure. Line voltage may be supplied using an external power source, or drawn from the input voltage terminal strip inside the equipment. Be sure the capacity of the power conductors supplying the equipment is rated for the additional power (VA) required by the E-Link Gateway. Use a wire that is one size larger than required for the amperage draw (maximum 400 mA) to connect the line voltage feed to the E-Link Gateway. For the line voltage power source, use a dedicated line (with a separate fuse) that is isolated (using a control transformer) from other equipment in the plant room that may generate Electromagnetic Interference (EMI).

Grounding

For the enclosure style, a ground wire must be connected directly to the enclosure supply power ground lug at the point of entry. A small label (Figure 7) identifies this grounding point. This ground wire should be connected through a continuous ground circuit to the incoming ground at the source transformer.

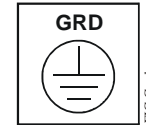

Figure 7: Grounding Label

Note: Besides providing safety protection, the ground connection plays an extremely important part in the operation of the communication circuitry.

**WARNING: Risk of Electric Shock.**

Ground the E-Link Gateway enclosure according to local, national, and regional regulations. Failure to ground the E-Link Gateway may result in electric shock and severe personal injury or death.

Protection of Communication Ports

When using RS-485 technology, it is possible that electrical disturbances, such as voltage spikes, can damage a circuit board. The E-Link Gateway includes tranzorbs on each RS-485 port to protect against damaging electrical spikes and stray voltage.

The equipment panel should also be equipped with protection against electrical disturbances. Whereas OptiView Micro Panels are equipped with onboard tranzorbs, other equipment panels may require the addition of an external board. Refer to the equipment documentation for details. Port 1 of the E-Link Gateway is also electrically isolated, providing a means of mitigating common mode voltage induced problems.

High Noise Environments

Electrical equipment that employs high speed switching circuits (Variable Speed Drives [VSD], Solid State Starters [SSS], and computing equipment) generates Electromagnetic Interference (EMI) noise and Radio Frequency Interference (RFI), which can generate transient voltage between ground points in the communication wiring. The RS-485 circuitry is designed to withstand some low transient voltage, but if this difference exceeds certain limits, it can permanently damage the RS-485 circuitry.

IMPORTANT: Ensure that the Micro Panel and the E-Link Gateway are powered from a source with a true earth ground.

IMPORTANT: Do not run communication cables in close proximity to, or parallel with, high-voltage power cables (maintain at least 457.2 mm [18 in.] of separation, or use a grounded metal conduit).

Electrical Noise Mitigation to Equipment

The likelihood of transient voltage is greatly reduced if the E-Link Gateway is close-coupled to the Micro Panel. Close-coupling requires that the E-Link Gateway and Micro Panel share the same line voltage power source and are physically close to one another. Typically, the E-link Gateway is mounted on the Micro Panel enclosure. This scenario ensures a short communication cable, which is usually protected entirely within the two enclosures.

Electrical Noise Mitigation for E-Link to BAS

When the E-Link is used in an electrically hostile environment (for example, with VSD-enabled equipment), a double-shielded cable should be used to help mitigate the adverse effects electrical noise can have on the system. The double-shielded cable should connect the E-Link's BAS port (Port 1 or Port 4) to the next controller(s) in the daisy-chained network.

The outer shield of the double-shielded cable should be grounded directly at the **low noise end** (the end most distant from the VSD), and ideally, indirectly through an appropriate capacitor at the **high noise end** (the end closest to the VSD). If a capacitor is not available, the outer shield may be left unconnected, or tied directly to ground. The best results on the site determine the specific termination strategy employed.

The inner shield of the double-shielded cable should be grounded directly at the **low noise end** (the end most distant from the VSD), and left open at the **high noise end** (the end closest to the VSD).

Types of Communication Ports

The E-Link Gateway uses three communication protocols to connect to other devices: RS-485 and FFT are used for multi-drop networking, whereas RS-232 is primarily used for point-to-point connectivity.

RS-485

The RS-485 standard uses three conductors to connect network nodes: two signal wires and a reference. The E-Link Gateway uses either a third wire for the reference or the building's infrastructure. The wiring method depends on the port being used: an electrically isolated Port 1 typically uses a third wire, whereas Ports 2 and 3 normally use chassis or building ground for the reference.

Setup and Adjustments

There are a number of settings that you may make on an E-Link Gateway or to the connected equipment.

Network Termination

Terminate all End-of-Line (EOL) devices at either end of the RS-485 bus (that connect to only one set of RS-485 network wires). EOL termination provides biasing of the network, and assists in returning the signal to a normal state in the event of voltage transients. If the E-link Gateway happens to be the end-of-line device, terminate the network by setting the EOL switch located above each of the E-Link Gateway's RS-485 ports to the ON position.

System Interface Module (SIM)



RS485
Port EOL
Not Terminated



RS485
Port EOL
Terminated

Figure 8: RS-485 EOL Switches

IMPORTANT: Ensure that the EOL switches are not set to the ON position for controllers that do not terminate the RS-485 network.

Media Access Control (MAC) Address

The E-Link Gateway's network hardware address is set on a single 8-way DIP switch. Switch 8, the T switch, is reserved to invoke Terminal mode on Port 3, leaving the remaining 7 switches for setting the address. Refer to the *E-Link Gateway Commissioning and Troubleshooting Technical Bulletin (LIT-12011238)* for more details.

System Interface Module (SIM)

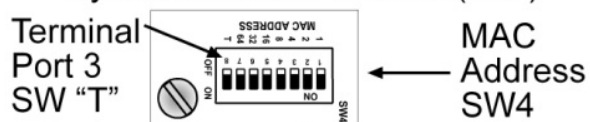

Figure 9: MAC Dip Switch

The network address is binary weighted, allowing you to set up to 127 unique addresses.

APP Group A

APP Group A uses a 6-way DIP switch to select the desired equipment's profile. This switch is also binary weighted, allowing up to 63 unique selections.

APP Group B

APP Group B uses a 4-way DIP switch to select the desired output protocol. This switch is also binary weighted, allowing up to 15 unique selections.

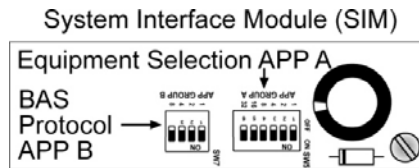

Figure 10: APP A and APP B DIP Switches

Push Button

The E-Link Gateway uses a push button (Figure 11) as a means of activating any user selections on APP Group A and APP Group B switches.

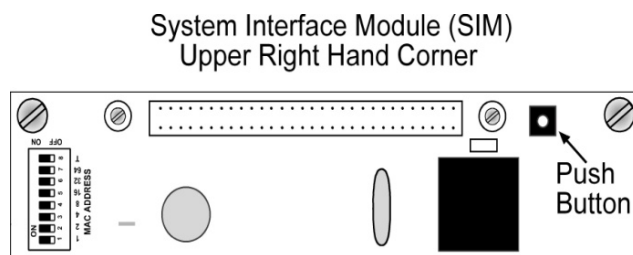

Figure 11: E-Link Gateway Push Button

Note: Refer to the *E-Link Gateway Commissioning and Troubleshooting Technical Bulletin (LIT-12011238)* for more details.

Equipment Configuration

Different pieces of equipment sometimes require a specific hardware configuration (jumper/switch settings) to enable communication with the E-Link Gateway. Refer to the equipment's installation literature for the proper configuration settings.

Setting the Rotary Switch on Chiller Panels

Some Micro Panels use a rotary switch to set their YORK Talk II address (YORK Talk address = Rotary Switch setting + 1). Since the E-Link Gateway uses a one-to-one relationship with the chiller panel, this switch is normally set to 0 (YORK Talk address 1). However, in a master/slave configuration, set the master Micro Panel rotary switch to 0, and the slave Micro Panel to 1. If the chiller Micro Panel is not equipped with a rotary switch, the YORK Talk address may be set using the Micro Panel keypad. In most cases, you can configure the setting, but some models are fixed and cannot be changed (refer to the equipment documentation for specific details).

Chiller Rotary Switch

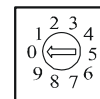

YT Address = Rotary Switch + 1

FIG:ChlRot

Figure 12: Micro Panel Rotary Switch

Network Topology

The E-Link Gateway has three serial communications ports and an optional LONWORKS port to connect equipment to a BAS system. Port 1 and Port 4 are designed as the BAS ports, with Port 1 used to support all RS-485 based communication protocols, and Port 4 used for LONWORKS connectivity with the addition of a LONWORKS ProtoCessor module.

Note: See Figure 24 and Figure 25 for additional information.

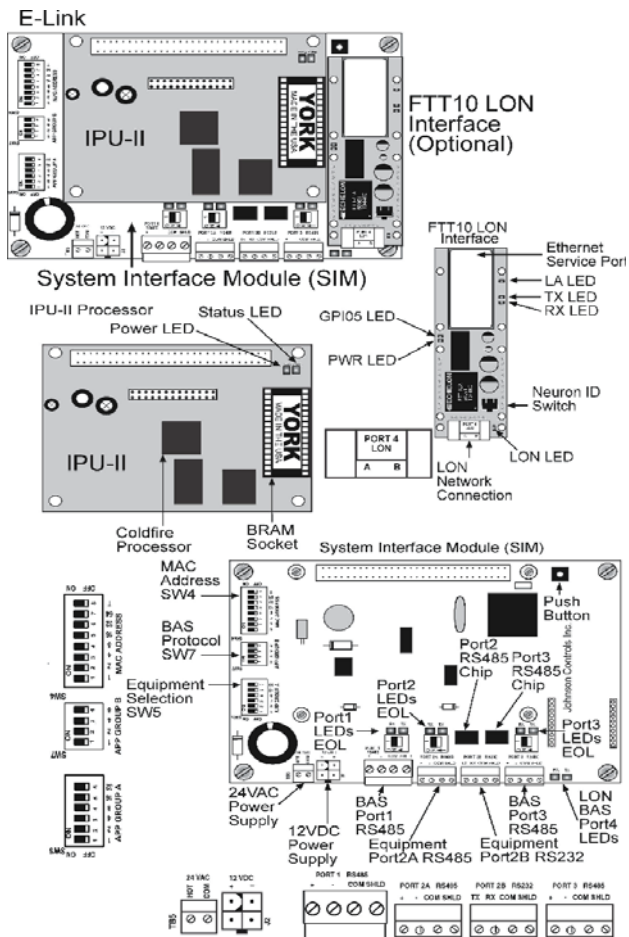

Figure 13: E-Link Gateway Component Identification

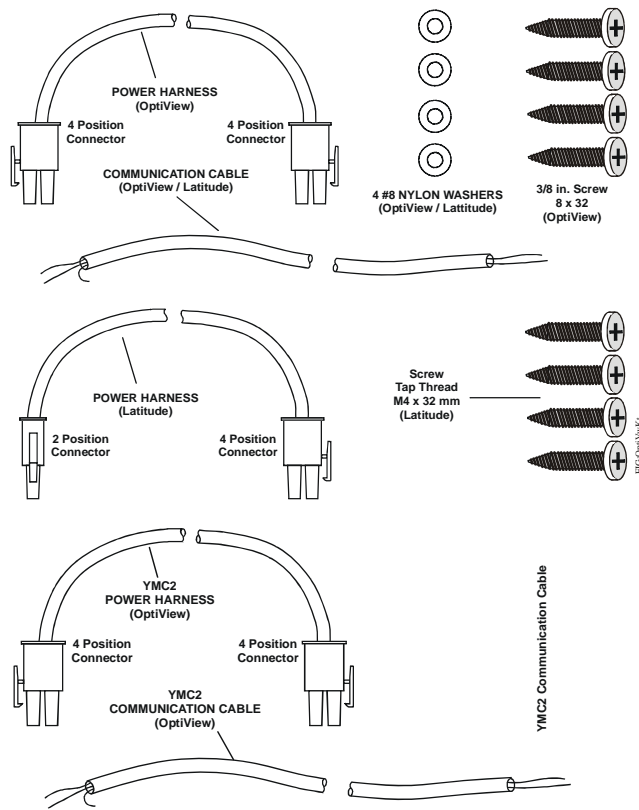

Figure 14: E-Link OptiView/Latitude Installation Kit (YK-ELNKOLK-0)

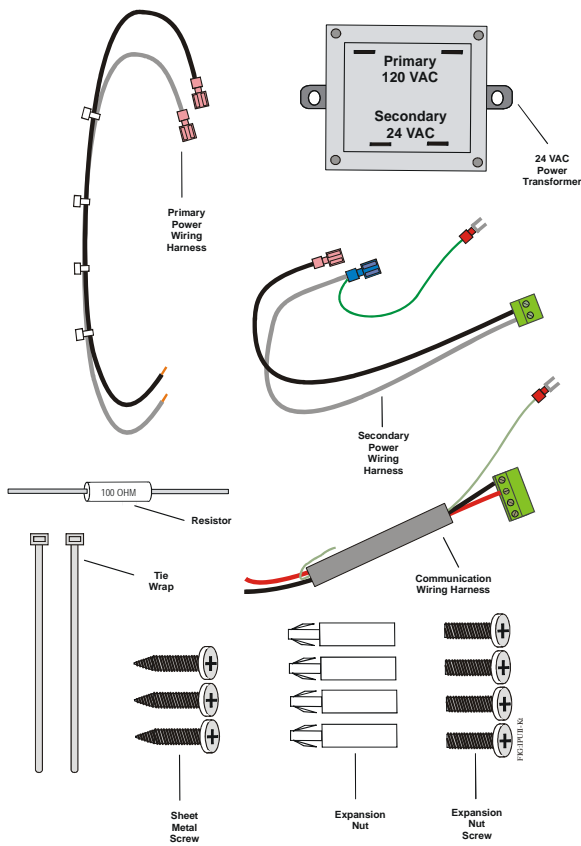
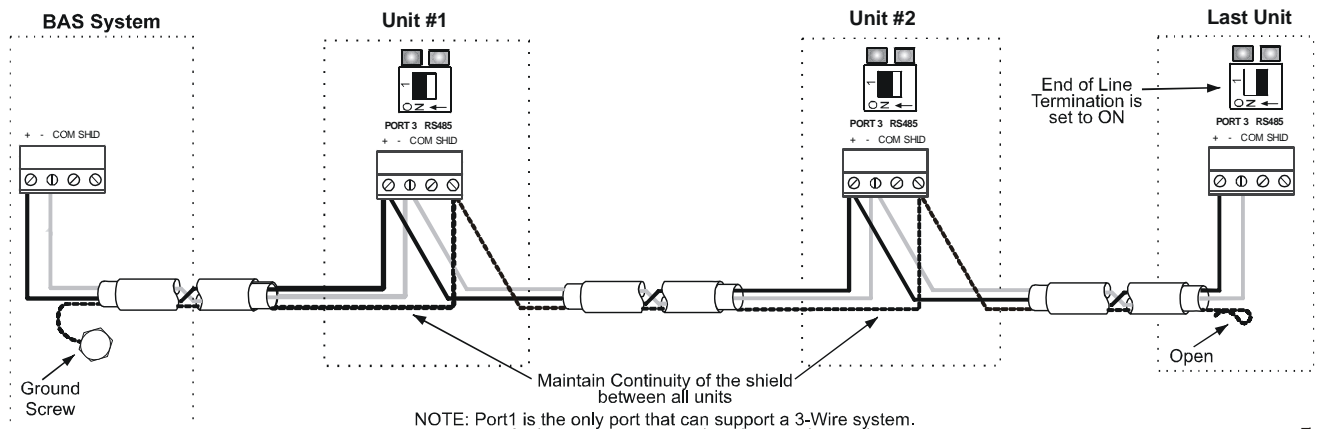

Figure 15: E-Link IPU-II Panel Installation Kit (YK-ELNKSTK-0 Contents)



- NOTE: Port1 is the only port that can support a 3-Wire system. In a 3 wire system, connect the wires as shown above. Connect the third wire to the REF terminal of the Port1 terminal blocks.
- NOTE: DO NOT Connect a Port1 3-Wire system communication trunk with any 2-Wire system communication trunk.
- NOTE: DO NOT Connect a Port4 2-Wire LON system communication trunk with any other communication trunk

Figure 16: BAS Trunk Shield Wiring

FIG-BAS_Shild

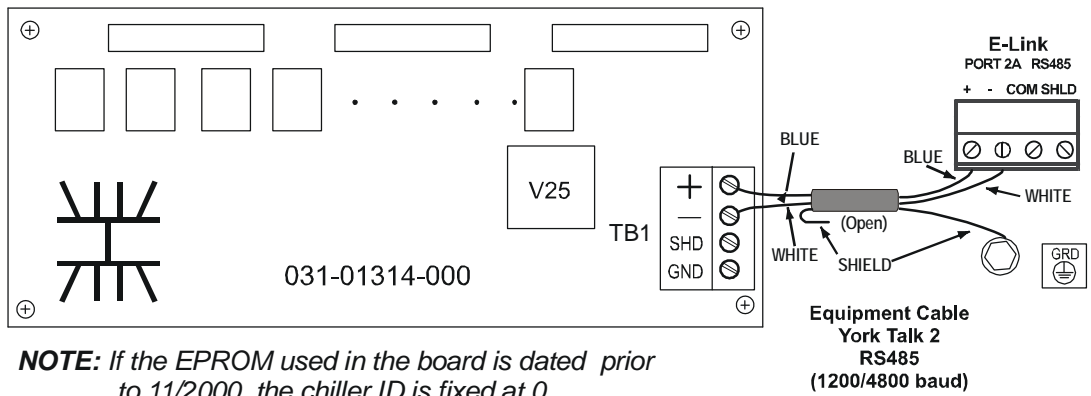
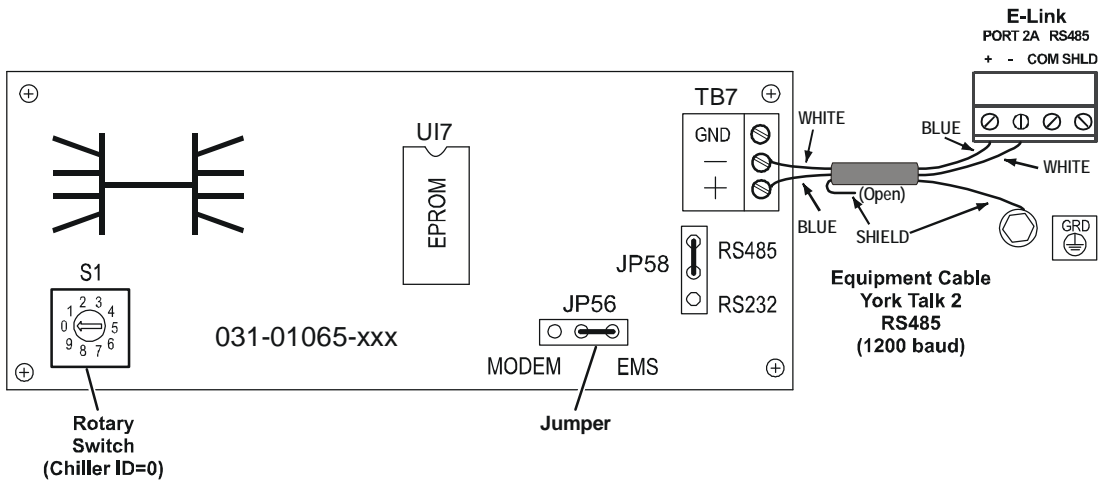

NOTE: If the EPROM used in the board is dated prior to 11/2000, the chiller ID is fixed at 0.
 If the EPROM used is dated after 11/2000, the chiller ID is software selectable through the micro panel

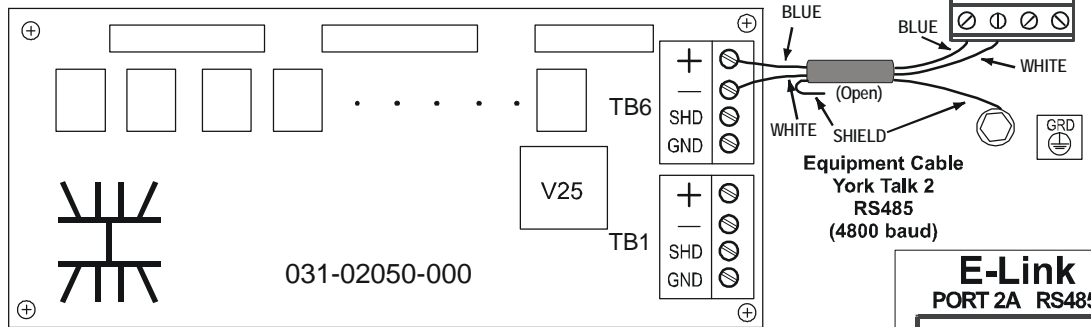

NOTE: The chiller ID is software-selectable through the micro panel keypad. Set the Chiller ID to 0 to make network address to 1.

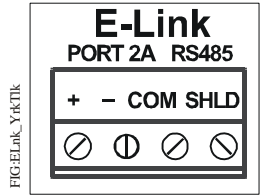

Equipment Connections

Figure 17: E-Link Gateway to YORK Talk II Equipment Connections
 (See Table 1 for board cross-reference.)

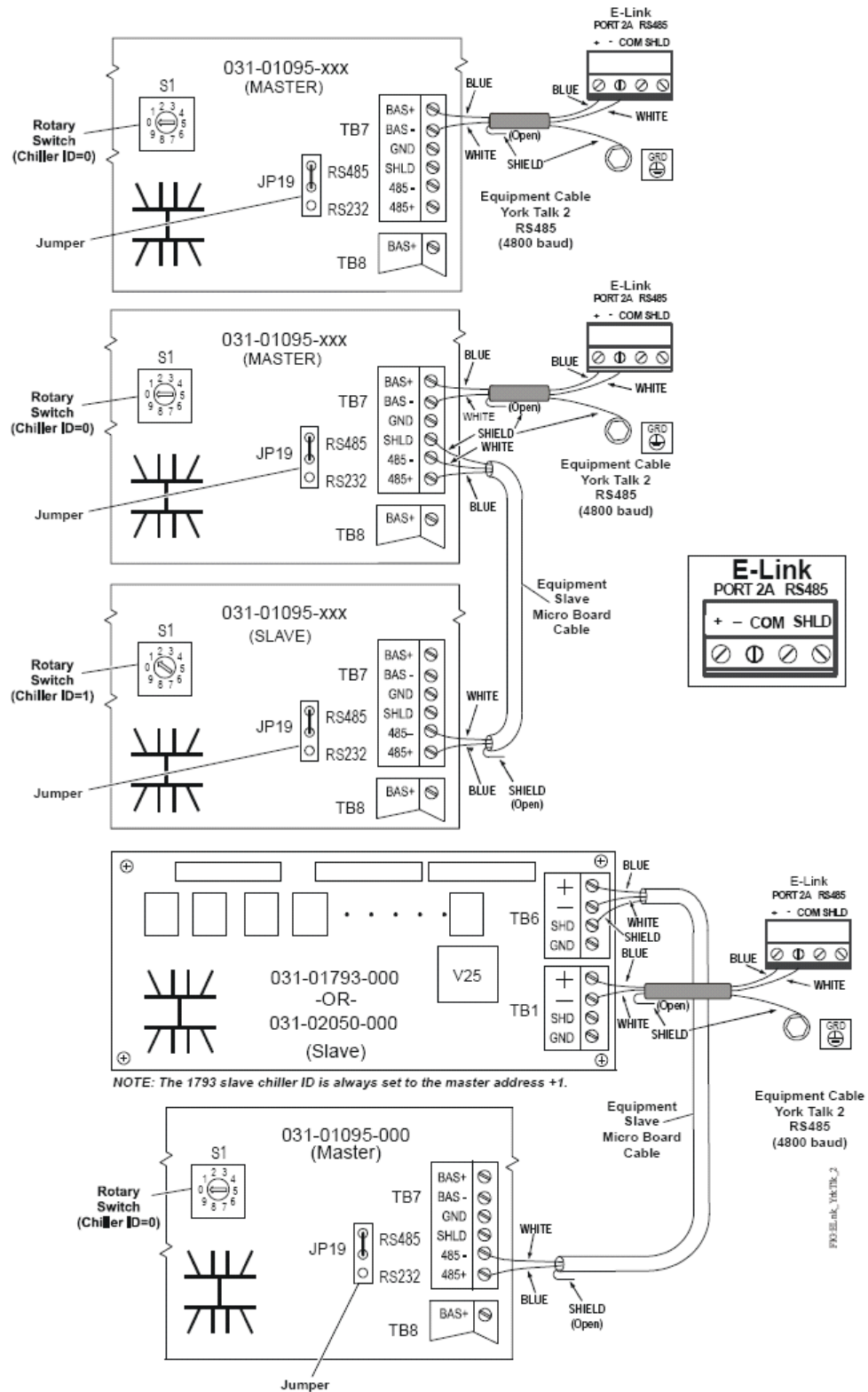

Figure 18: E-Link Gateway to YORK Talk II Equipment Connections (Continued)
(See Table 1 for board cross-reference.)

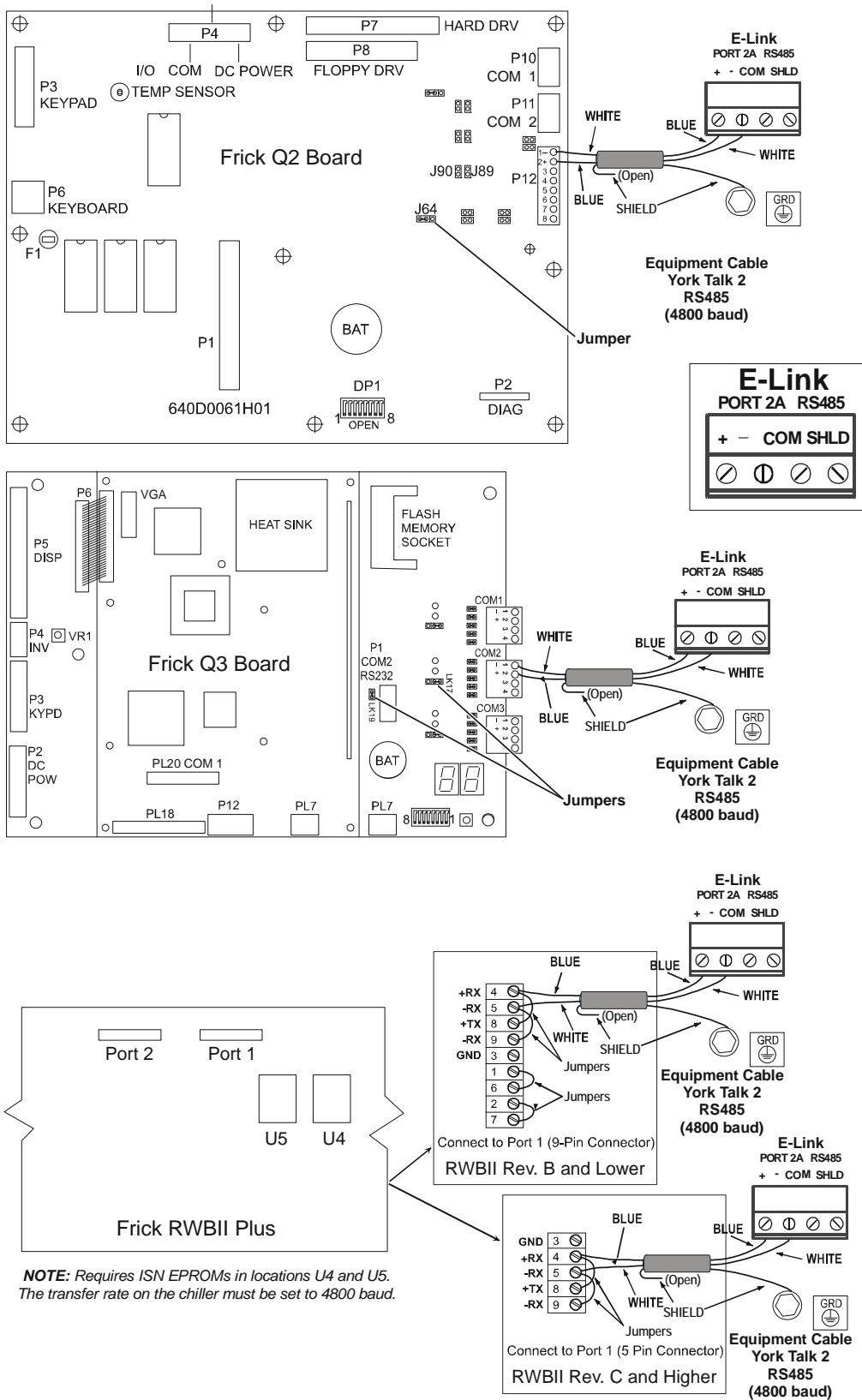
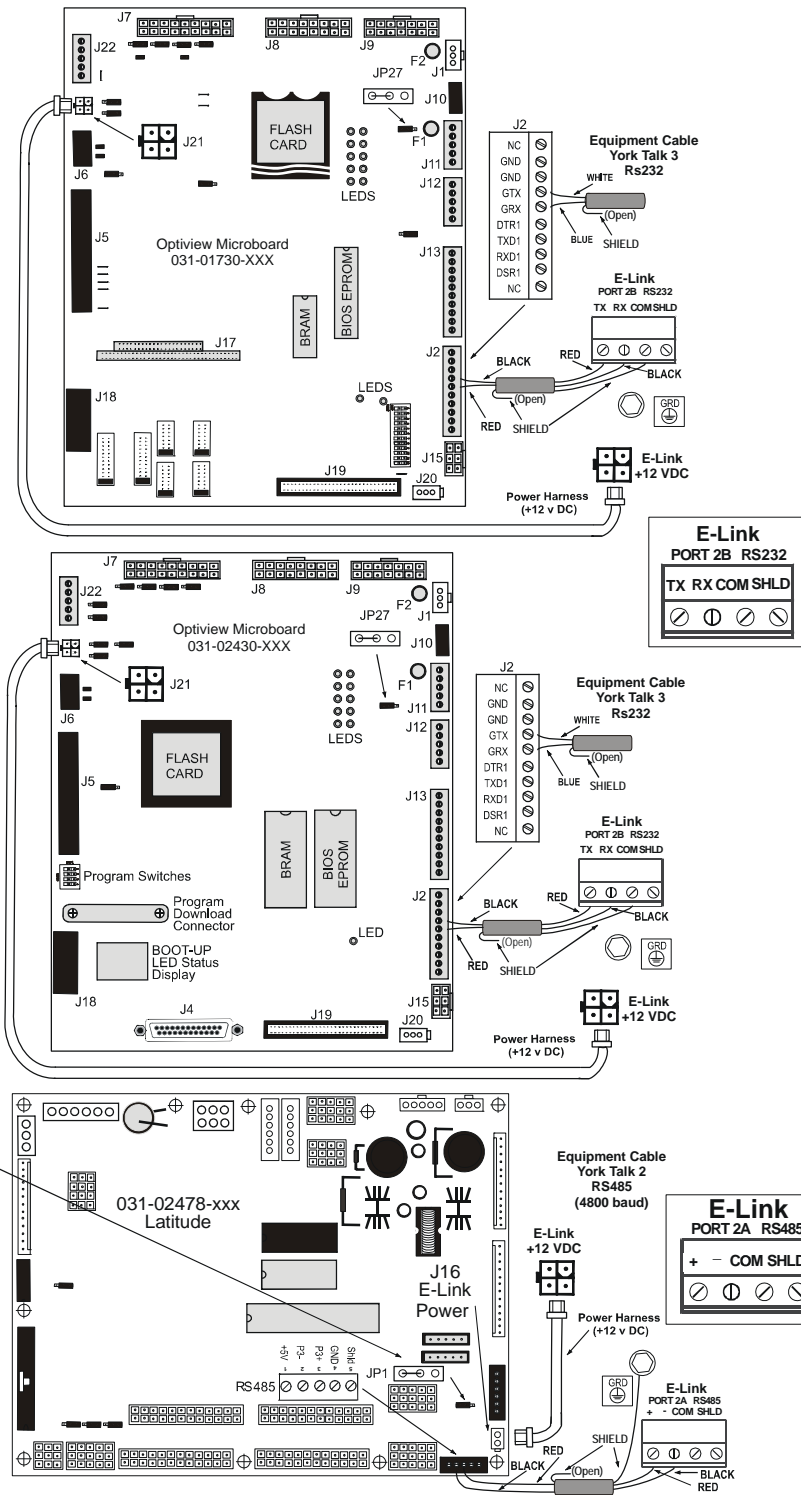

Figure 19: E-Link Gateway to YORK Talk II Equipment Connections (Continued)
 (See Table 1 for board cross-reference.)



Note: JP1 on the 031-02478-xxx board must be set to the RS485 position when the E-Link BAS communication is required.

Note: Enabling any of the Latitude's PRINT functions will disrupt BAS/E-Link communications. See YORK Equipment Form 201.21-NMx in the *Installation, Operation & Maintenance (IOM) Air-Cooled Screw Liquid Chillers* manual for more information.

Figure 20: E-Link Gateway to OptiView and Latitude/YCAV/YCIV/YVAA Equipment Connections (See Table 1 for board cross-reference.)

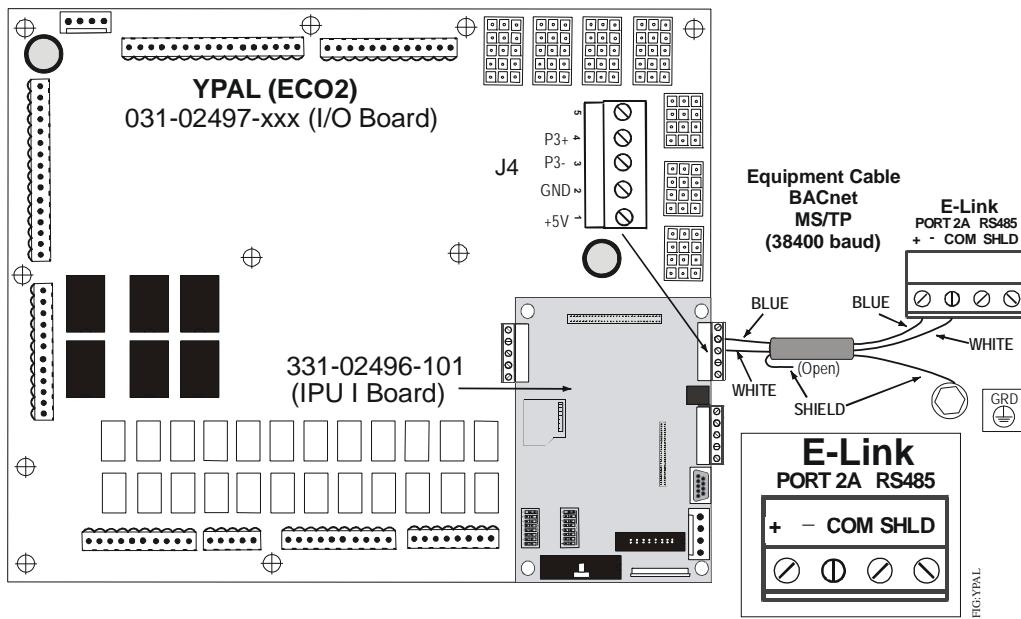

YPAL (ECO2) Setup for MS/TP Bus:
 DE Modifier Address set to 50.
 DE Modifier Offset set to -1.
 P1 Protocol set to BACnet.
 P1 Manual MAC Address set to -1.
 P1 Baud Rate set to 38400.
 P1 Parity set to None.
 P1 Stop Bits set to 1.
 MAC Address Switch (SW2) set 1 ON, all others OFF.
 Note: Do not set the chiller address and the E-Link address to the same value. This causes a conflict on the MS/TP Bus resulting in no communication between the chiller IPU I board and the E-Link Gateway.

Figure 21: E-Link Gateway to YPAL (ECO2) Equipment Connections

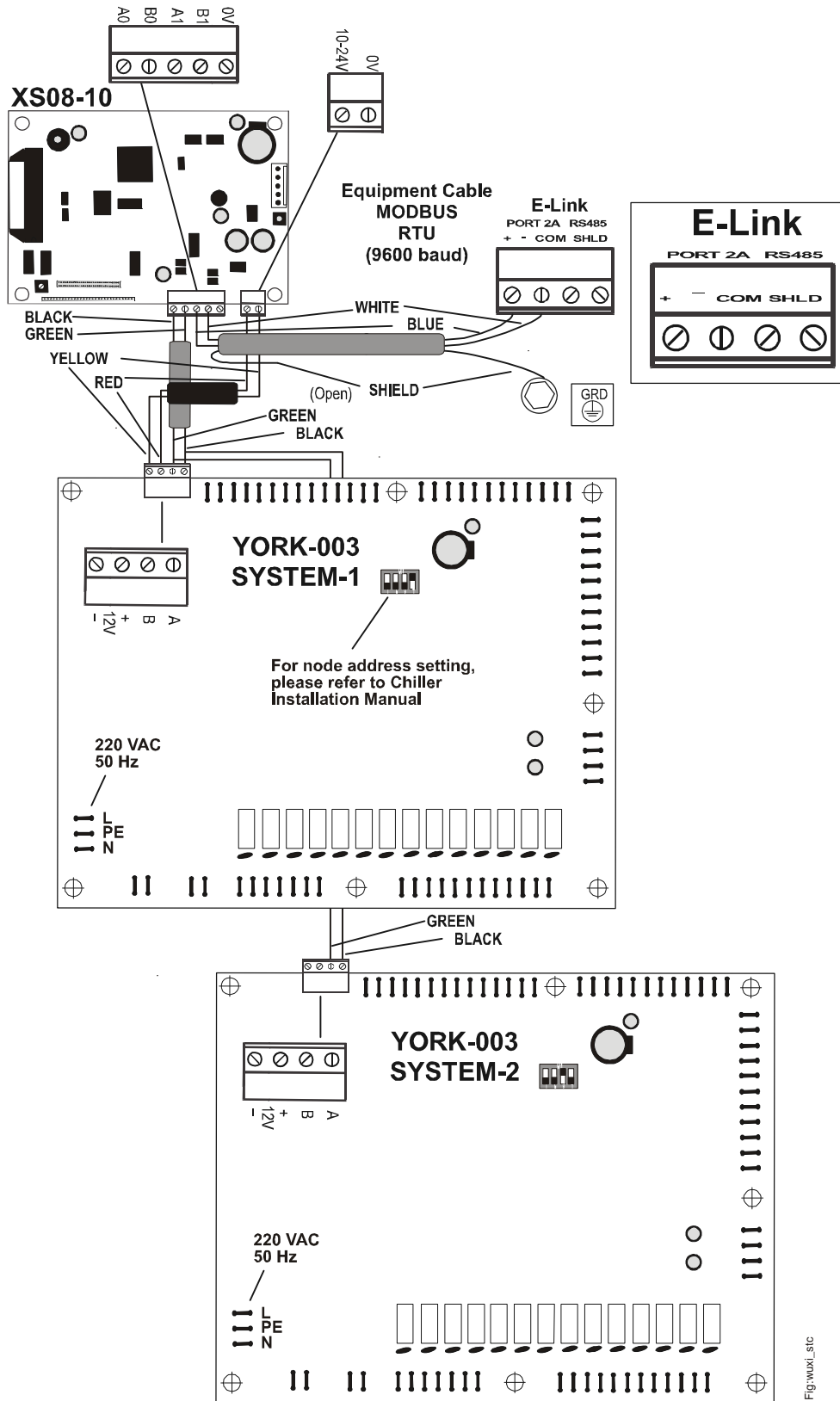
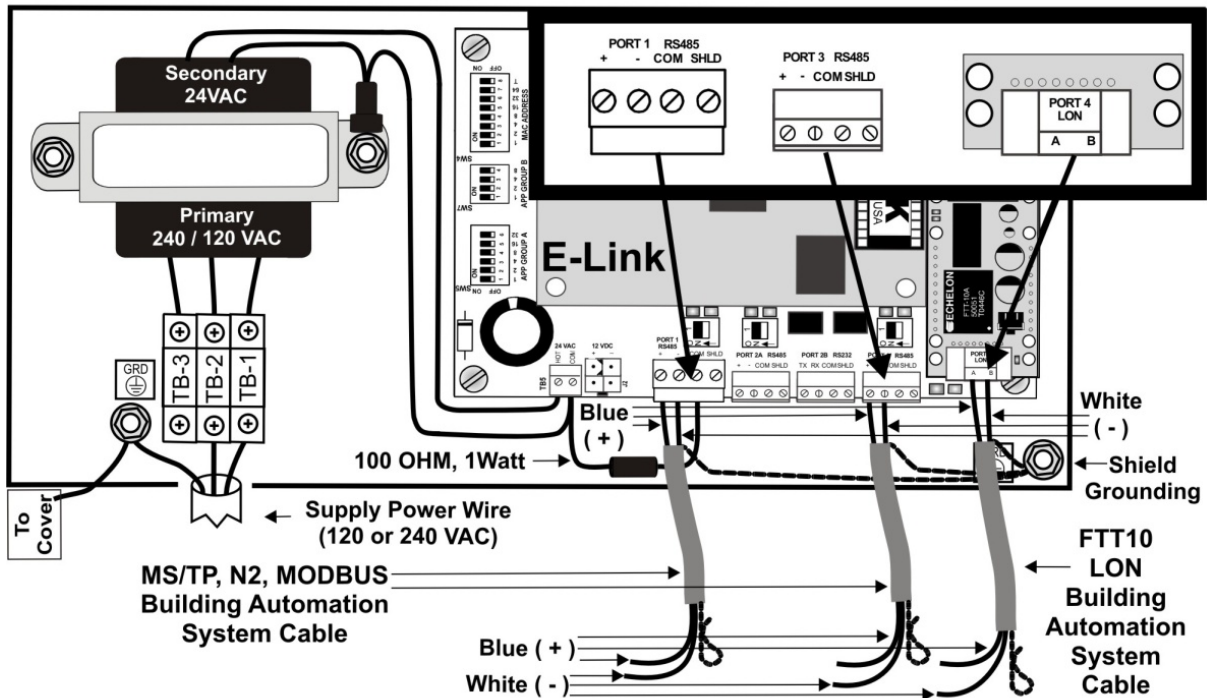
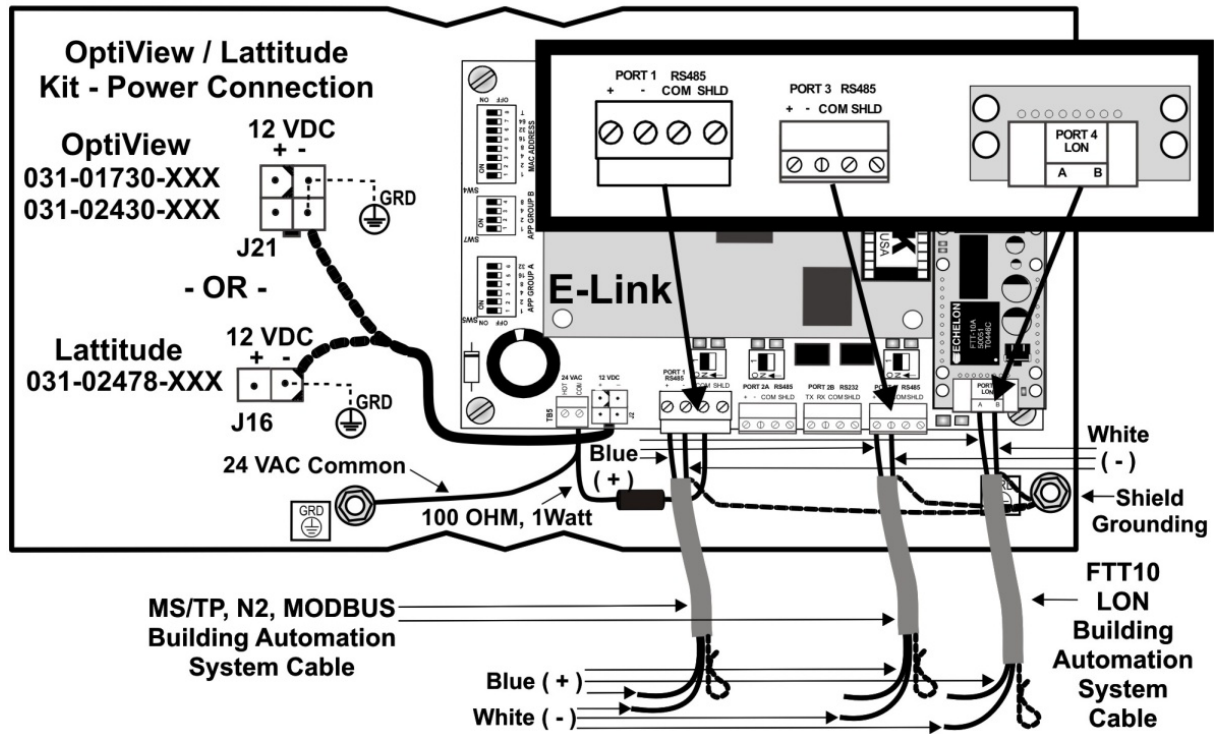

Figure 23: E-Link Gateway to Wuxi STC YEWS-D1/YEAS/YGAS Equipment Connection

E-Link External to Equipment Installation - 2 Wire BAS System



E-Link Internal to Equipment Installation - 2 Wire BAS System



- NOTE -

In either 2 wire installation, Port 1 utilizes the ground path for communication return path

Figure 24: E-Link Gateway Communication Port Connections to a BAS System

E-Link External to Equipment Installation - 3 Wire BAS System (Port 1 Only)

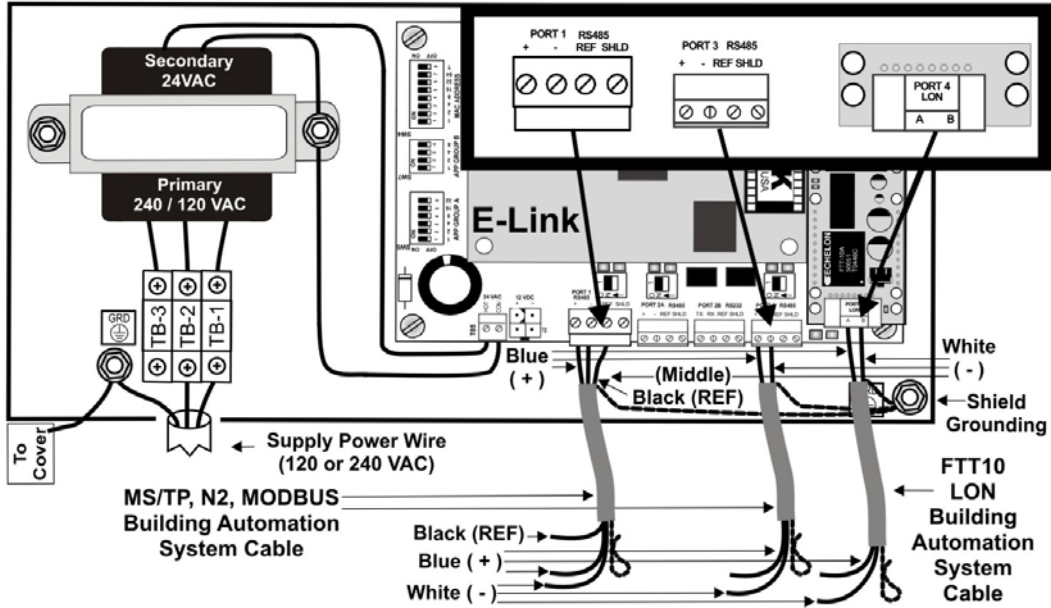

E-Link Internal to Equipment Installation - 3 Wire BAS System (Port 1 Only)

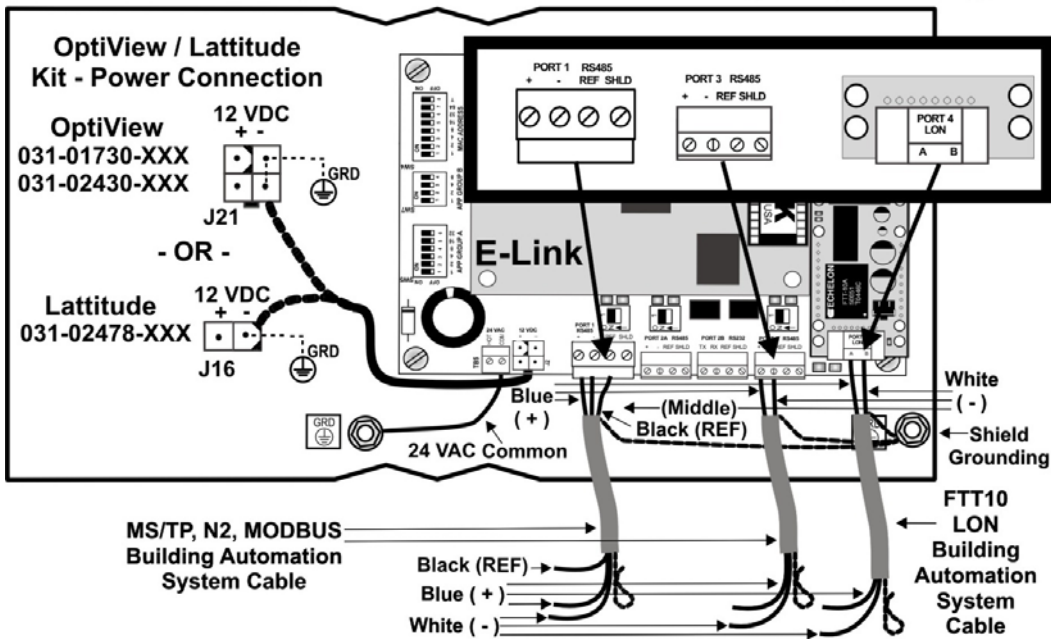



Figure 25: E-Link Gateway Communication Port Connections to a BAS System (Continued)

Note: Connect a ground strap between the panel's ground path and the E-Link's common path only if this connection has not been made elsewhere in the configuration.

Repair Information

If the E-Link Gateway fails to operate within its specifications, replace the unit. For a replacement E-Link Gateway, contact the nearest Johnson Controls representative.

Technical Specifications

Power Requirements		<p>External to Equipment (Inside Enclosure): 120/240 VAC Primary 50/60 Hz, 24 VAC Secondary Transformer (+10%/-15%), 400 mA, Nominal 12 VA</p> <p>Internal to Equipment E-Link Gateway Board Assembly: 24 VAC ($\pm 15\%$), 50/60 Hz, 400 mA, Nominal 12 VA, 12 VDC (+50%/-2%), 400 mA, Nominal 12 VA</p>
Addressing		<p>Addressing is selectable by the MAC Address Switch – 8 Position Dip Switch using Switches 1 through 7.</p> <ul style="list-style-type: none"> • BACnet MS/TP Valid Addressing 1 to 127 • Modbus RTU Valid Addressing 1 to 127 • N2 Valid Addressing 1 to 127
Installation Environment		Indoor, Dry
Ambient Operating Conditions		<p>Temperature: -40 to 85°C; (-40 to 185°F)</p> <p>Humidity: 0% to 95% Noncondensing</p>
Ambient Storage Conditions		<p>Temperature: -40 to 90°C (-40 to 194°F)</p> <p>Humidity: 0 to 95% RH, Noncondensing</p>
Power		<p>External to Equipment (Inside Enclosure): One 3-Position Terminal Block for 120/240 VAC Supply Power</p> <p>Internal to Equipment E-Link Gateway Board Assembly: Removable Terminal Plug for 24 VAC Supply Power and Removable Terminal Plug for 12 VDC Supply Power</p>
Communication Wiring Terminations		<p>Equipment Protocol is selectable by the APP Switch Group A – 6-Position Dip Switch.</p> <p>Port 2A: RS485 Equipment Port Supporting BACnet MS/TP and YORK Talk II Protocols with Available EOL Termination Switch</p> <p>Port 2B: RS232 Equipment Port Supporting YORK Talk 3 Protocol</p> <p>BAS Protocol is selectable by the APP Switch Group B – 4-Position Dip Switch.</p> <p>Port 1: RS485 BAS Port Supporting BACnet MS/TP, Modbus RTU, N2 Protocols With Available EOL Termination Switch</p> <p>Port 3: RS485 BAS Port supporting BACnet MS/TP, Modbus RTU, N2 Protocols With Available EOL Termination Switch; When Selected by Switch 8 of the MAC Address Dip Switch, Terminal Communications</p> <p>Port 4: RS485 BAS Port Supporting the LONWORKS FTT10 Protocol</p>
Wiring		<p>Network Cable: 0.51 mm (24 AWG) (3 Cores Plus Shield)</p> <p>Power Cable: 1.02 mm (18 AWG) Copper Wire Rated for 10 Amperes Per Core at 250 VAC</p>
Materials		<p>External to Equipment: Metal Enclosure with Removable Lid, E-Link Gateway Board Assembly, Power Transformer</p> <p>Internal to Equipment E-Link Board Assembly: E-Link Gateway Board Assembly</p>
Mounting		<p>External to Equipment: Screw Mount Enclosure</p> <p>Internal to Equipment: E-Link OptiView/Latitude and IPU-II installation kit</p>
Dimensions		<p>External to Equipment: 241.3 x 136.5 x 63 mm (9-1/2 x 5-3/8 x 2-1/2 in.)</p> <p>Internal to Equipment: 102 x 152 x 25.4 mm (4 x 6 x 1 in.)</p>
Shipping Weight		<p>External to Equipment: 2 kg (4.5 lb)</p> <p>Internal to Equipment: 227 g (8 oz)</p>
Compliance 	United States	UL Listed 916/FCC Part 15 Conducted and Radiated
	Europe	CE Mark - Johnson Controls, Inc. declares that this product is in compliance with the essential requirements and other relevant provisions of the EMC Directive 2004/108/EC and Low Voltage Directive 2006/95/EC.

The performance specifications are nominal and conform to acceptable industry standards. For application of conditions beyond these specifications, consult the local Johnson Controls office. Johnson Controls, Inc. shall not be liable for damages resulting from misapplication or misuse of its products.



Building Efficiency
507 E. Michigan Street, Milwaukee, WI 53202

*Metasys® and Johnson Controls® are registered trademarks of Johnson Controls, Inc.
All other marks herein are the marks of their respective owners. © 2011 Johnson Controls, Inc.*