

Data sheet

Motor operated valve, type ICMTS with actuator, type ICAD 600A-TS



The ICMTS is a direct operated motorised valve driven by actuator type ICAD 600A-TS.

The ICMTS is designed to regulate the flow of transcritical gas or subcritical liquid from the gascooler in transcritical CO₂ systems. The ICMTS can also be used for other control functions in CO₂ systems.

The ICMTS valve is designed so that the opening and closing forces are balanced.

ICAD 600A-TS

ICAD 600A-TS actuators can be controlled using the following signals:

- 0-20 mA
- 4-20 mA (default)
- 0-10 V
- 2-10 V

ICAD 600A-TS actuators can also operate an ICMTS valve as an On/Off function supported by a digital input.

The ICMTS valve can be operated manually via the ICAD 600A-TS actuator or via the Multi-function tool for ICMTS (see the ordering section).

Features (valve)

- Designed for high pressure CO₂ systems with applications for a maximum working pressure of 140 bar / 2030 psig.
- Applicable to R744 (CO₂).
- Direct coupled connections.
- Connection types are DIN butt weld.
- Non-alloyed quality steel.
- Low weight and compact design.
- Regulating cone ensures optimum regulating accuracy, particularly at part load.
- Manual opening possible via ICAD 600A-TS or Multi-function tool.
- The PTFE seat provides excellent valve tightness.
- Magnet coupling - real hermetic sealing.
- ICAD 600A-TS include encoder function that will provide a true valve position feedback to Danfoss controller or non-Danfoss control systems.

Design (valve)

Connections

ICMTS valves are available with DIN butt weld connections.

Approvals

The ICMTS valve concept is designed to fulfil global refrigeration requirements.

The ICMTS valves are approved in accordance with the European standard specified in the

Pressure Equipment Directive and are CE marked. For further details / restrictions - see Installation Instruction. The ICAD 600A-TS actuator is UL listed.

Valve body and top cover material
Low temperature steel



ICMTS valves	
Nominal bore	DN ≤ 25 (1 in.)
Classified for	Fluid group I
Category	Article 3, paragraph 3

Contents	Page
Features (valve).....	1
Design (valve)	1
Technical data (valve).....	3
Function (valve)	3
ICAD 600A-TS:	
Features (actuator).....	4
Technical data (actuator).....	4
Approvals	5
Function (actuator)	5
ICAD-UPS for ICMTS	6
Material specification	8
ICMTS Application	9
ICMTS capacities.....	10
Ordering	10
Accessories	11
Dimensions	13
Connections.....	13
General operation	
Alarms	14
Parameter list.....	15
Reset to factory setting:.....	16
	17

Fail Safe supply options

In the event of a power failure, multiple fail safe options are possible, provided that a ICAD-UPS or similar is used. During power failure, ICAD 600A-TS can be selected to:

- Close ICMTS
- Open ICMTS
- Stay in the position it was in, prior to power failure.
- Go to a specific ICMTS valve opening degree.

See the section ICAD UPS for further information.

Please note:
a fail safe supply (battery or UPS) is required.



Technical data (valve)

Refrigerants
Applicable to R744 (CO₂).
ICMTS valves must not be used with flammable refrigerants. For further information, please contact your local Danfoss sales company.

- **Temperature range:**
Media: -60/+120°C (-76/+248°F).
- **Pressure**
The valve is designed for:
Max. working pressure: 140 bar g (2030 psig)

- **Surface protection**
ICMTS:
The external surface is treated in order to provide good corrosion protection.
- **Max. opening pressure differential (MOPD)**
ICMTS:
90 bar (1305 psi)
- The time it takes to move from Closed to Open position or in reverse order with maximum selected speed at ICAD 600A-TS is 3 seconds.

Function (valve)

The ICMTS motor valve is designed for use with ICAD 600A-TS.

The driving force from the actuator is transferred via a magnetic coupling (a) through the stainless steel top housing (b), thus eliminating the need for a packing gland. The rotational movement of the magnetic coupling (a) is transferred to a spindle (c) which in turn provides the vertical movement of the cone (d) and PTFE valve plate (e), to open and close the valve. The closing force of the actuator combined with the PTFE valve plate (e) and valve seat (f) provides an effective seal to prevent leakage across the valve port, when the valve is in the closed position. To prevent damage to the PTFE valve plate (e) and seat (f) from system debris, it is recommended to install a filter in the system.

Valve inlet pressure (P₁) acting on the underside of the PTFE valve plate (e) also passes through the hollow cone assembly (d) on to the top of the piston (g) and balances the pressure acting on the piston (g). Any trapped liquid across the throttle cone (d) is equalised down to the valve outlet without affecting the valve performance.

The actuators have a fully weather protected enclosure with none of the moving parts exposed to the environment.

The fast acting actuators and balanced valve design results in the valve being able to move from the fully closed to the fully open position in about 3 seconds.

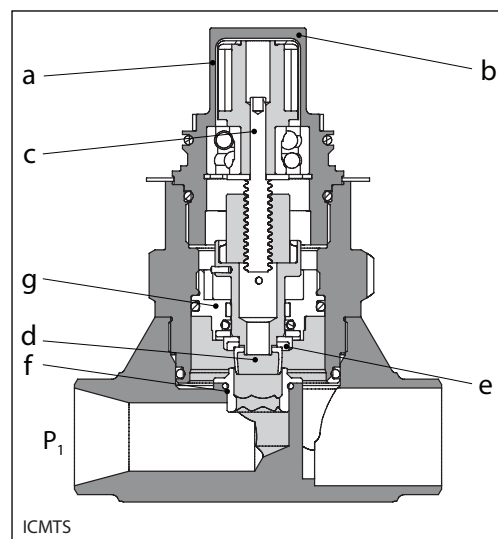

The smallest cones (A33 and A) are log-shaped in order to provide optimum regulation at small capacities and high pressure differentials.

The first version of the ICMTS valve features V-shaped A cones. Please contact your local Danfoss sales company for further info.

Bigger cones (B and C) are V-shaped in order to provide an optimum regulating curve for higher capacities.

ICAD 600A-TS

The actuator type 600A-TS is designed specifically for ICMTS valves. The actuator type 900 can be used for ICMTS as well, however it consumes more energy than ICAD 600A-TS for similar applications.

The ICAD 600A-TS is controlled via a modulating analogue signal (e.g. 4-20 mA/2-10 V) or a digital

ON/OFF signal. ICAD 600A-TS incorporates an advanced MMI (Man Machine Interface), including continuous display of Opening Degree, which gives the user a very advanced and flexible setup procedure that can meet many different applications. The ICMTS valve is typically controlled by the Danfoss EKC 326A controller.

Features (actuator)

- Specifically designed for ICMTS valve
- Advanced and high speed Digital Stepper Motor Technology
- Seven segment LCD display including three programming keys
- Valve opening degree can be observed continuously.
- Can easily be configured to different applications on-site. (change speed, ON/OFF, modulating valve)
- Open – Close time: 3 seconds
- Modulating or ON/OFF operation
- Multiple speed selection during operation
- Logging of old alarms
- Password protection
- Control input signal:
4-20 mA, 0-20 mA, 0-10 V, 2-10 V
- Position feed back : 0-20 mA, 4-20 mA (ICMTS)
- 3 Digital ON/OFF feedback
- Resolution: 20 micron/step (0.02 mm stroke pr. step)
- Total steps: 250
- Auto Calibration, Neutral zone
- In the event of a power failure, multiple fail safe options are possible. During power failure, ICAD 600A-TS can be selected to:
Close ICMTS
Open ICMTS
Stay in the position it was in, prior to power failure.
Go to a specific ICMTS valve opening degree.
- Hermetic magnetic motor
- Enclosure: IP 67 (~NEMA 6)
- Approvals: CE, UL, CRN
- Connectors for easy installation and servicing
- Can be controlled by Danfoss EKC 326A controller and integrated into Danfoss ADAP-KOOL® system.

Technical data (actuator)

- *Materials*
Housing
Aluminium
Top part of ICAD 600A-TS:
PBT thermo plastic
- *Weight*
ICAD 600A-TS: 1.2 kg (2.64 lb)
- *Temperature range (ambient)*
-30°C/+50°C (-22°F/122°F)
- *Enclosure*
IP 67 (~NEMA 6)
- *Cable connection*
Can be ordered with or without cables included.
If ordered with cables:
2 cables in length of 1.5 m length (60 in.) with M12 connectors included
Supply cable
3 × 0.34 mm² (3 × ~22 AWG)
Ø4.8 mm (diameter 0.19")
Control cable
7 × 0.25 mm² (7 × ~24 AWG)
Ø6 mm (diameter 0.24")

Electrical data

Supply voltage is galvanic isolated from Input/Output.

Supply voltage: 24 V d.c., + 10% / -15%
Load: ICAD 600A-TS: 1.2 A

Fail safe supply: Min. 19 V d.c., max. 26.4 V d.c.
Load: ICAD 600A-TS: 1.2 A

Battery capacity:

For each open/closed cycle
ICAD 600A-TS:
Speed Parameter i04=100 (Max. Speed) : 2 mAh
Speed Parameter i04=1 (Min. Speed) : 200 mAh

Analogue Input - Current or Voltage

Current: 0/4-20 mA
Load: 200 Ω
Voltage: 0/2-10 V d.c.
Load: 10 kΩ

Analogue Output: 0/4-20 mA
Load: ≤ 250 Ω

Digital input - Digital ON/OFF input by means of volt-free contact (Signal/Telecom relays with gold-plated contacts recommended) – Voltage input used

ON: contact impedance < 50 Ω)
OFF: contact impedance > 100 kΩ

Digital Output - 3 pcs. NPN transistor output
External supply: 5-24 V d.c.

(Same supply as for ICAD 600A-TS can be used, but please note that the galvanically isolated system will then be spoiled).

Output load: 50 Ω
Load: Max. 50 mA

Technical data (cont.)

Cable connection - Two 1.5 m (60 in) cables premounted

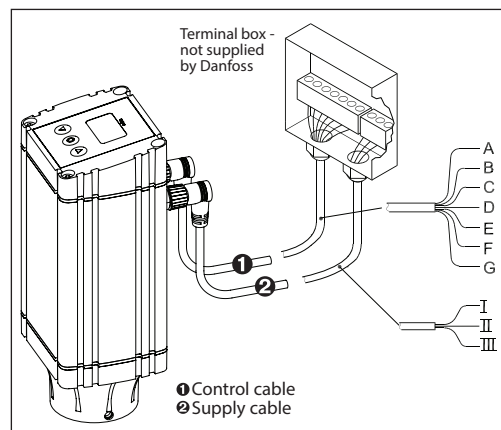

Ref.	Colour		Description
A	Black	-	Common Alarm
B	Brown	-	ICMTS fully open
C	Red	-	ICMTS fully closed
D	Orange	-	GND ground
E	Yellow	+	0/4 - 20 mA Input
F	Green	+	0/2 - 10 V Input
G	Blue	+	0/4 - 20 mA Output

I	Black	+	Fail safe supply Battery / UPS* 19 V d.c.
II	White	+	Supply voltage
III	Brown	-	24 V d.c.

* Uninterruptable Power Supply

Note: Colour code changed when compared to older colour wiring diagram.

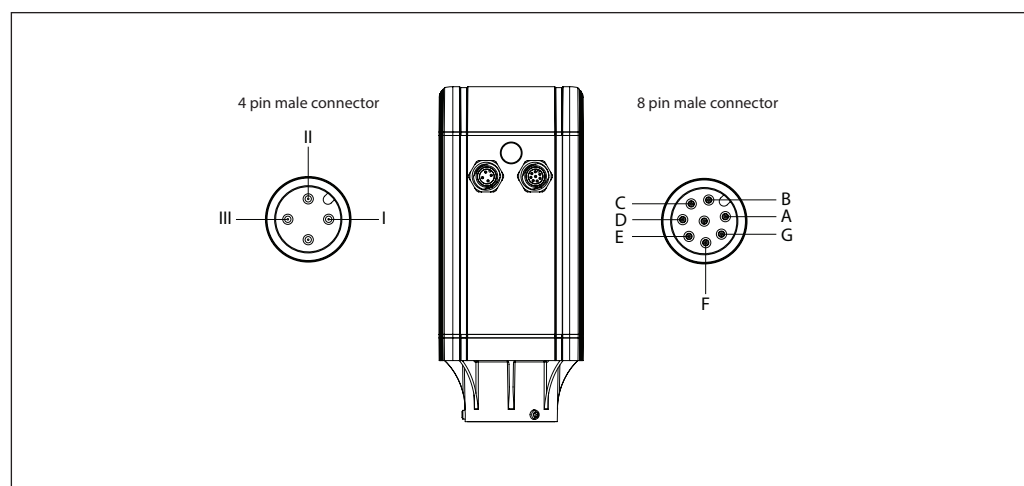

Approvals

CE according to 89/336 EEC (EMC)
Emission: EN61000-6-3
Immunity: EN61000-6-2
UL
CRN

Function (actuator)

The design of ICAD 600A-TS is based on a digital stepper motor technology combined with an advanced MMI (Man Machine Interface), that gives excellent possibilities for having a high degree of flexibility with the same type of ICAD 600A-TS actuator.

The Opening Degree (0-100 %) of the actual ICMTS valve installed can be continuously observed on the ICAD 600A-TS display.

The advanced menu system will allow several parameters to be adjusted to obtain the required function. Many different parameters can be configured, among these:

- Modulating and ON/OFF control
- Analogue input
0- 20 mA or 4-20 mA
0-10 V or 2-10 V
- Analogue output
0- 20 mA or 4-20 mA

- Automatic or manual control
- Change of ICMTS valve speed
- Automatic calibration
- Multiple Fail Safe set-up options during power cut

For service all Input and Output signals can be recalled and observed from the ICAD 600A-TS display.

A password protection has been linked to the parameter of entering the correct ICMTS valve to avoid unintentional and non-authorised operation.

Function (actuator)
(continued)

The design of ICAD 600A-TS is based on a digital stepper motor technology combined with an advanced MMI (Man Machine Interface), that gives excellent possibilities for having a high degree of flexibility with the same type of ICAD 600A-TS actuator.

The Opening Degree (0-100 %) of the actual ICMTS valve installed can be continuously observed on the ICAD 600A-TS display.

The advanced menu system will allow several parameters to be adjusted to obtain the required function. Many different parameters can be

configured, among these:

- Modulating and ON/OFF control
- Analogue input
0- 20 mA or 4-20 mA
0-10 V or 2-10 V
- Analogue output
0- 20 mA or 4-20 mA
- Automatic or manual control
- Change of ICMTS valve speed
- Automatic calibration
- Multiple Fail Safe set-up options during power cut

ICAD-UPS for ICMTS



The solution of connecting ICMTS with ICAD 600A-TS to ICAD-UPS will give one of the following possibilities in the event of power failure:

- close ICMTS
- open ICMTS
- stay
- go to a specific ICMTS Opening Degree.

When power supply has been re-established the system will automatically return to normal operation.

ICAD-UPS is designed for using with ICMTS valve.

In the event of power failure, there is a need to make sure that the ICMTS goes to a safe position. ICAD-UPS can be connected to the ICAD 600A-TS.

Facts and features

- Industrial product.
- Can support up to
 - 8 pcs. of ICAD 600A-TS
- Integrated solution - battery and UPS.
- *Industrial approvals:*
CE, UL, GL (Germanischer Lloyd).
- DIN rail mounting.
 - LED indication
 - Green (Power ON)
 - Yellow (Flashing: charging, Constant: Buffer mode (Failsafe supply to ICAD 600A-TS))
 - Red (Battery fully discharged/Battery faulty)
- 24 V d.c. supply → Same transformer as for ICAD 600A-TS can be used. Only +0.5 A extra load on the transformer.
- Check of battery every 60 sec.
- Adjustable buffer time*. (1, 2, 3, 5, 10, 15, 20, 30 or infinity) = Ensures longer battery life time.
- Forced remote shutdown in buffer mode via digital input.
- 3 digital volt free relay change over contacts for signals to PLC systems. (Power OK, Buffer mode (failsafe supply to ICAD 600A-TS), Alarm).

* Buffer time is defined as the period where ICAD 600A-TS is only powered from the ICAD-UPS (i.e. not from main supply). On ICAD-UPS there is an adjustable buffer time setting (1, 2, 3, 5, 10, 15, 20, 30 min. or infinity). If set to 3, ICAD-UPS will switch off power to connected ICAD 600A-TS, 3 minutes after the power failure occurs. This ensures that the internal battery inside ICAD-UPS does not fully discharge.

Code number: **027H0182**

For further information, please see the instruction DKRCI.PI.HV0.B.

ICAD-UPS applications

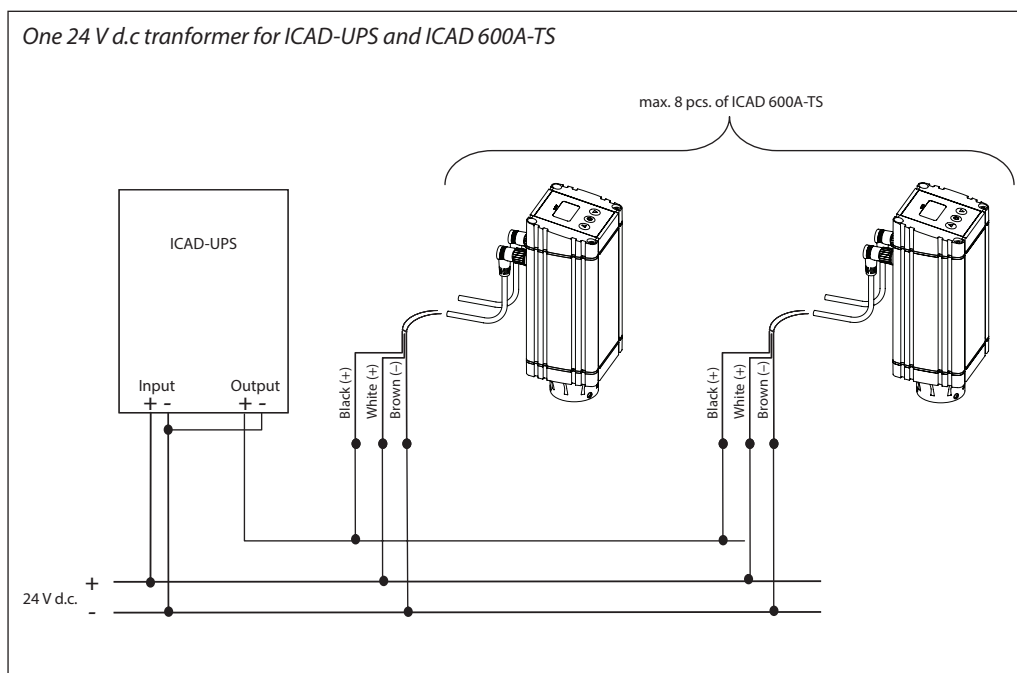
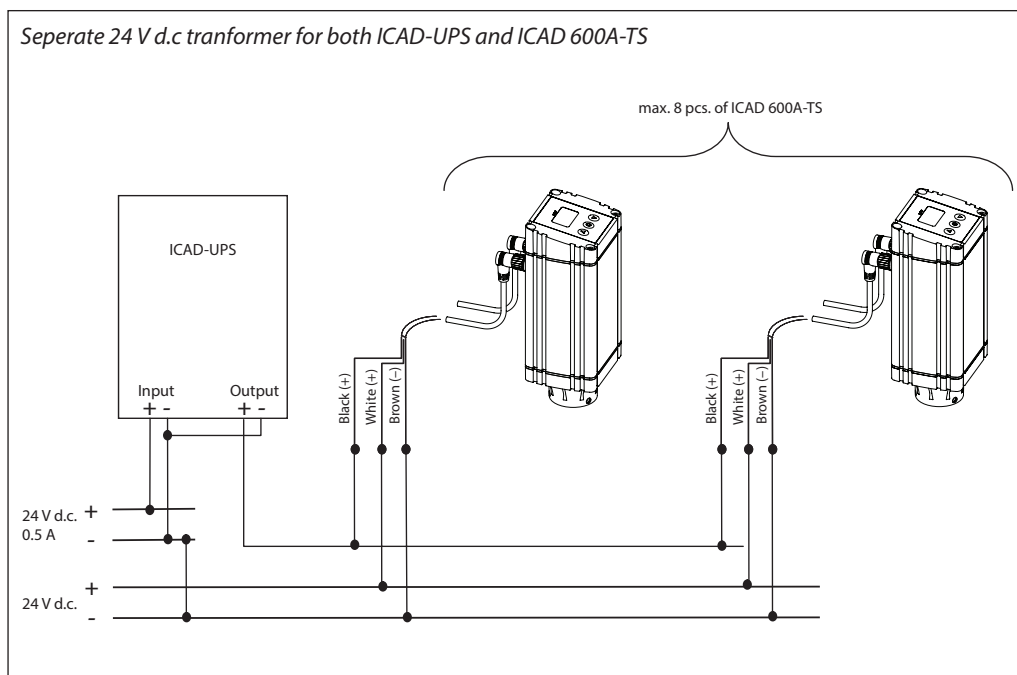

Material specification

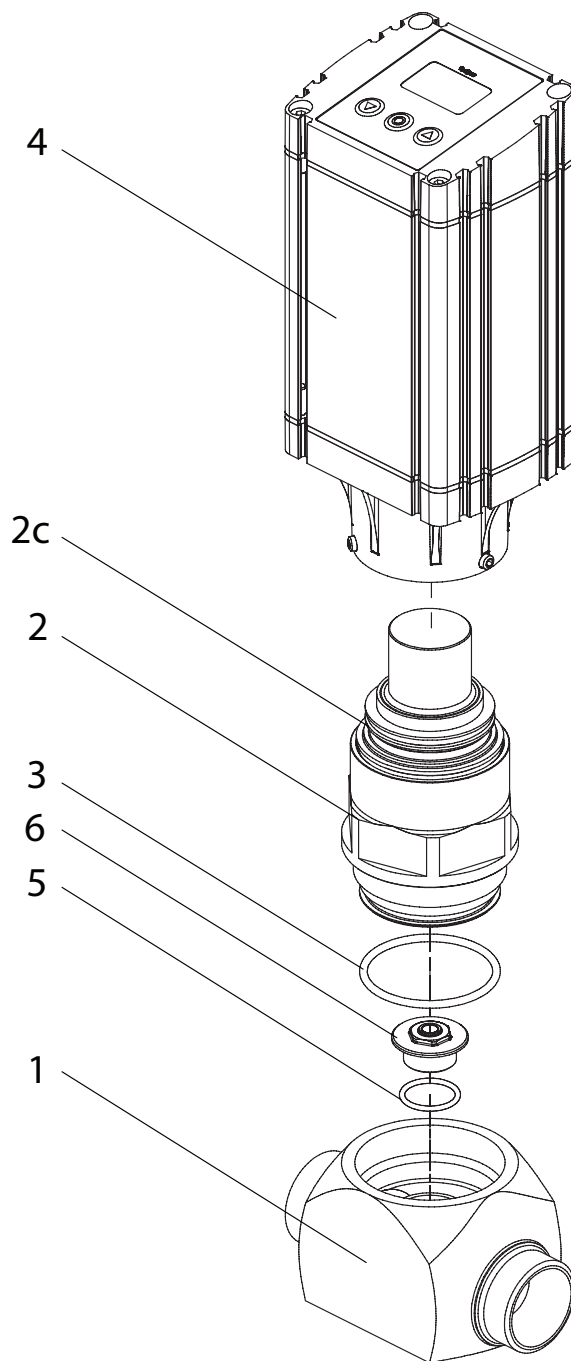

No.	Part	Material	EN	ASTM
1	Housing	Low temperature steel	S235J2, EN10025	A515
2	Top cover / function module	Low temperature steel	S355J2, EN10025	LCC, A352
2c	O-ring	Cloroprene (Neoprene)		
3	O-ring	Cloroprene (Neoprene)		
4	Actuator			
5	O-ring	Cloroprene (Neoprene)		
6	Seat	stainless steel		

ICMTS Application

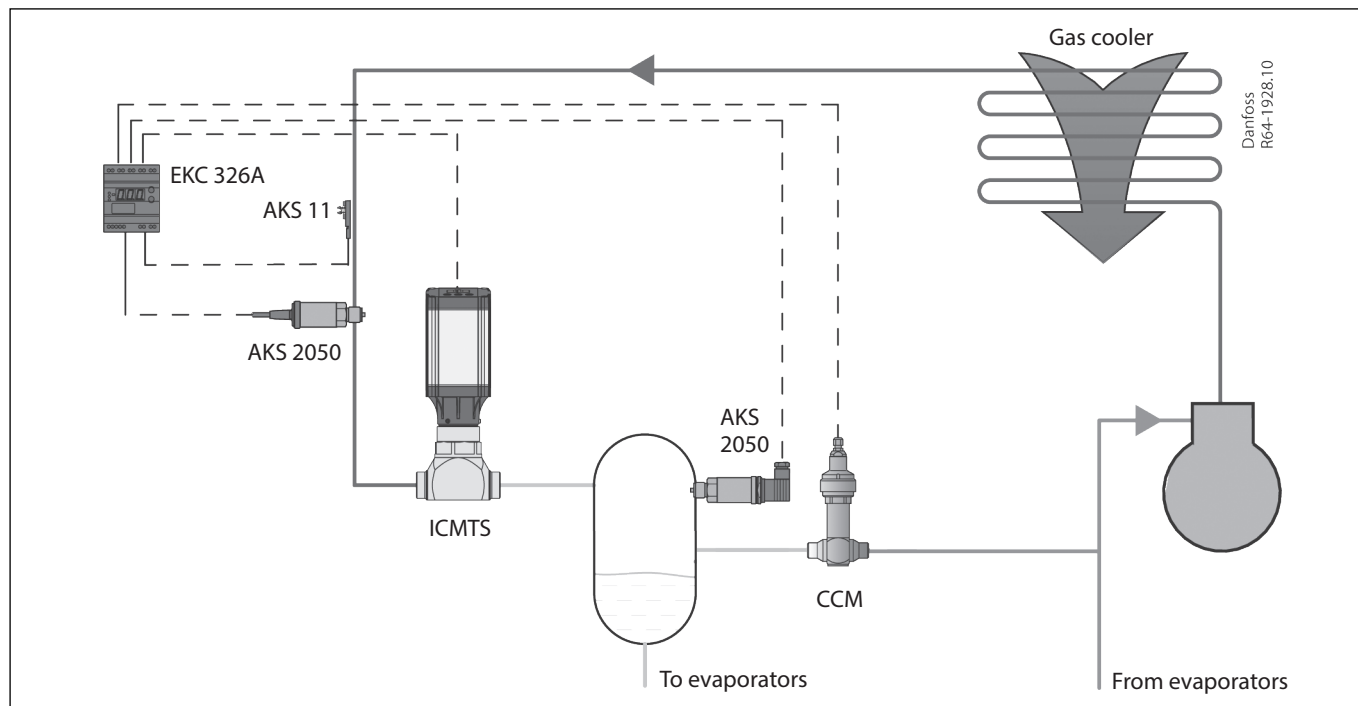

The ICMTS valve is developed for transcritical CO₂ applications. The ICMTS valve can be used in systems with flash gas bypass, parallel compression as well as in stand-alone application. The ICMTS valve can be used in transcritical and subcritical conditions.

The most typical application is with flash gas bypass.

Pressure optimisation is performed by the Danfoss EKC 326A controller and the ICMTS valve which is installed at the outlet of the gas cooler (see the figure above). This design provides the possibility to optimise gas cooler pressure and intermediate receiver pressure independently.

The pressure in the receiver is one important parameter, but the design of the receiver is also important. It typically acts as a liquid separator as well.

In order to keep the intermediate pressure low, flash gas is expelled through a gas bypass valve to the suction side of the compressor. The two phase mixture from the ICMTS valve has to be separated before gas enters the gas bypass.

Please refer to the Danfoss Application guide, DKRCE.PA.R1.A for more information on CO₂ systems.

ICMTS capacities

It is relatively complex to correctly size a valve for transcritical applications, especially as the mass flow of the refrigerant changes, drastically moving from transcritical to subcritical conditions. At the same time, temperature variations in the intermediate vessel downstream of the valve, will not significantly affect the sizing of the valve.

It is recommended to calculate the ICMTS valve using Danfoss DIRcalc™ software following these steps:

- Calculate the ICMTS valve as an expansion valve in the liquid line with the following conditions: $T_{\text{cond}} = +30^{\circ}\text{C}$, T_{evap} = temperature in the intermediate vessel, 0 K subcooling.

- Check the selected valve for the winter conditions: e.g. $T_{\text{cond}} = +15^{\circ}\text{C}$ with 5 K subcooling
- Possible part load of the system at $T_{\text{cond}} = +30^{\circ}\text{C}$, T_{evap} = temperature in the intermediate vessel, 10 K subcooling. (night operation or the smallest capacity step of the power pack).
The part load of the valve should be above 10%.

Quick capacity selection could be done using the following table:

Table 1

	0 K subcooling in the subcritical mode		
	+15/+5°C [kW]	+30/+5°C [kW]	+38 (100 bar)/ +5°C [kW]
ICMTS 20-A33	16.7	16.1	25
ICMTS 20-A	50	48	75
ICMTS 20-B	291	278	423
ICMTS 20-C	479	454	675

Table 2

	5 K subcooling in the subcritical mode		
	+15/+5°C [kW]	+30/+5°C [kW]	+38 (100 bar)/ +5°C [kW]
ICMTS 20-A33	18.5	23	25
ICMTS 20-A	56	69	75
ICMTS 20-B	325	400	423
ICMTS 20-C	540	655	675

Table 3

	10 K subcooling in the subcritical mode		
	+15/+5°C [kW]	+30/+5°C [kW]	+38 (100 bar)/ +5°C [kW]
ICMTS 20-A33	20.4	26.5	25
ICMTS 20-A	61	80	75
ICMTS 20-B	355	470	423
ICMTS 20-C	585	760	675

Please contact your local Danfoss sales office if you need assistance in your selection of ICMTS valves.

Ordering

Type	Code number
ICMTS 20-A33	027H1084
ICMTS 20-A	027H1085
ICMTS 20-B66	027H1093
ICMTS 20-B	027H1086
ICMTS 20-C	027H1087

ICAD 600A-TS with cables	027H9078
ICAD 600A-TS without cables	027H9123

Data sheet | Motor operated valve, type ICMTS with actuator, type ICAD 600A-TS
Accessories

Service kit 1 - valve orifice

Code number	027H1192 - Gasket kit with orifice for B and C cones
Code number	027H1193 - Gasket kit with orifice for A33 and A (new design) cones

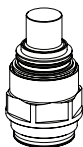
Service kit 2 – Top part with cone complete

Type	Code number
ICMTS 20-A33 top part with cone and orifice kit	027H1088
ICMTS 20-A top part with cone and orifice kit	027H1080
ICMTS 20-B66 top part with cone and orifice kit	027H1094
ICMTS 20-B top part with cone and orifice kit	027H1081
ICMTS 20-C top part with cone and orifice kit	027H1082

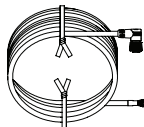
Cable for ICAD 600A-TS

Cable length	Code number
Cable set 1.5 m, female	027H0426
Cable set 10 m, female	027H0427

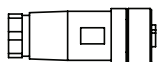
Connectors for ICAD 600A-TS

Connector type	Code number
Two Female Connectors with screw terminals: - connector for power - connector for control signals	027H0430

ICAD-UPS

Code number	027H0182
--------------------	-----------------

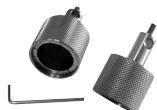
Multi-function tool

Code number	027H0181
--------------------	-----------------

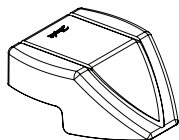
ICAD 600A-TS Protection Cap

Code number	027H0431
--------------------	-----------------

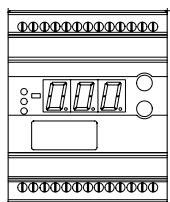
EKC 326A

Code number	084B7252
--------------------	-----------------

Technical data

Supply voltage	24 V a.c. +/-15% 50/60 Hz (the supply voltage is galvanically separated from the input and output signals)	
Power consumption	Controller	8 VA
Input signal	Pressure transmitter	Ratiometric, AKS 2050
	Pressure transmitter	Ratiometric, AKS 2050
	Digital input from external contact function	
	Voltage signal	0-10 V Signal range = 2-10 V
Sensor input	1 pcs. Pt 1000 ohm	
Alarm relay	1 pcs. SPST	250 V a.c. AC-1: 4 A (ohmic) AC-15: 3 A (inductive)
Actuator	ICAD 600A-TS mounted on ICMTS	Voltage signal 0-10 mA
	CCM	Step motor
Data communication	Possible to connect a data communication module type AKA 174	
Environments	-10 to +55°C, during operations	
	-40 to +70°C, during transport	
	20 - 80% Rh, not condensed No shock influence / vibrations	
Enclosure	IP 20	
Weight	300 g	
Mounting	DIN rail	
Display	LED, 3 digits	
Terminals	max. 2.5 mm ² multicore	
Approvals	EMC acc. EN 61000-6-3 and EN 61000-6-2	
	LVD acc. EN 60730-1 and EN 60730-2-9	

Data sheet | Motor operated valve, type ICMTS with actuator, type ICAD 600A-TS

 Accessories
 (continued)

AKS 2050

Code number	060G5750 (-1 to 59 bar)
Code number	060G5751 (-1 to 99 bar)
Code number	060G5752 (-1 to 159 bar)

Technical data

Operating range	as mentioned above
Permissible working pressure (PB)	250 bar
Compensated temperature range	0 to +80°C
Connection	G 3/8 A 2) - Thread ISO 228/1 - G 3/8 A (BSP).

Connecting plug with 5 m cable
(a pressure transducer with the cap gets a IP67 rating)

Code number	060G1034
--------------------	-----------------

Plug Pg 9

Code number	060G0008
--------------------	-----------------

AKS 11

Code number	084N0003 – cable length: 3.50 m
Code number	084N0005 – cable length: 5.50 m
Code number	084N0008 - cable length: 8.50 m

Technical data

Max. ambient temperature	100°C
Cable type	PVC
Electrical connection	Cable
Measuring range	-50 - 100°C
Resistance value	1 x Pt 1000
Tolerance	EN 60751 Class B
Wires	2 pcs.

For selection of CCM motorised valves for CO₂ gas bypass application please see DKRCI.PD.VK1.A.

Dimensions

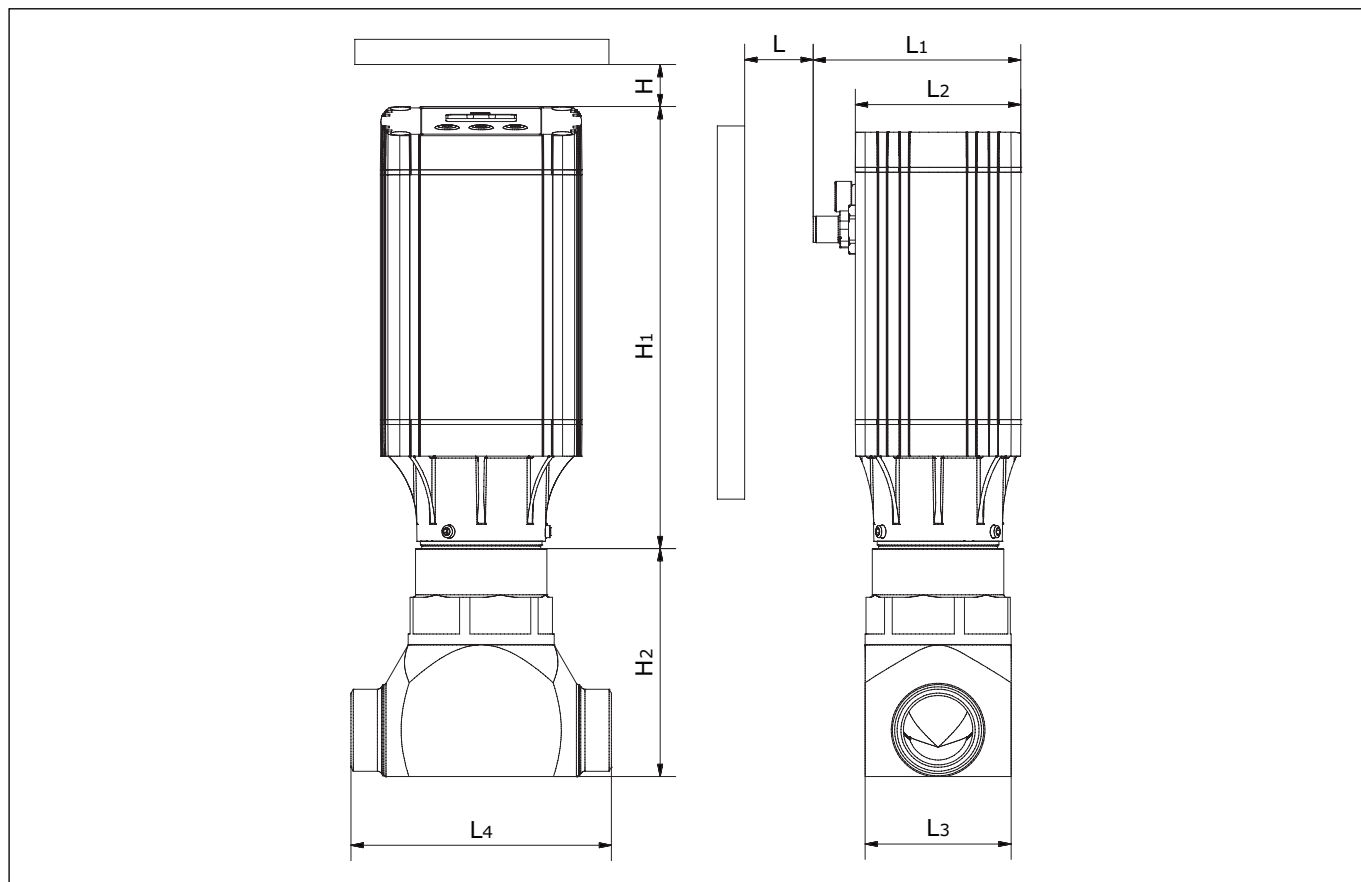

Connection		H	H ₁	H ₂	L*	L ₁	L ₂	L ₃	L ₄	Weight ICMTS incl. ICAD 600A-TS
25 D (1 in.)	mm	40	195	94	65	86	68	60	107	3.3 kg
	in.	1.58	7.68	3.7	2.56	3.39	2.68	2.36	4.21	6 lb.

* include space for ICAD Protection cap

Connections

D: Butt weld DIN (EN 10220)

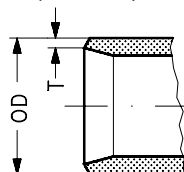

Size mm	Size in.	OD mm	T mm	OD in.	T in.		
25	(1)	33.7	2.6	1.327	0.103		

General operation

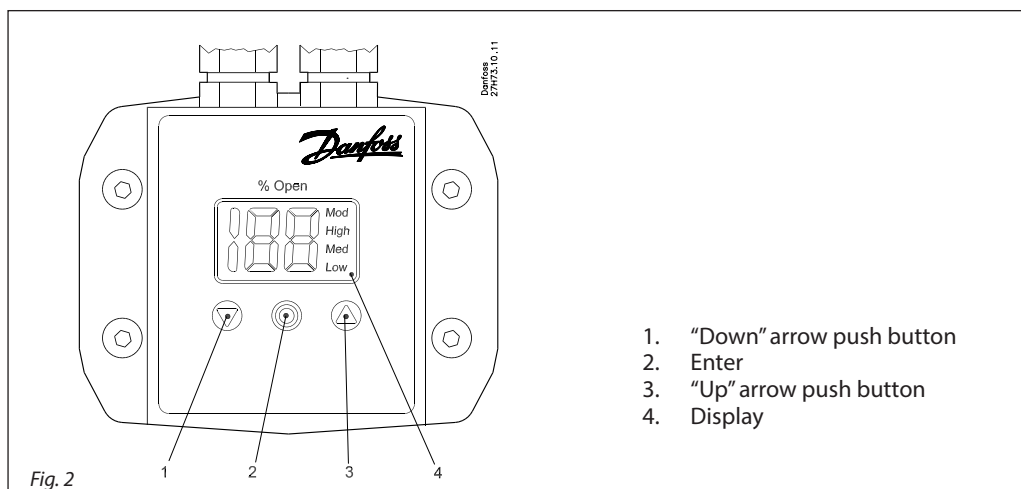

ICAD 600A-TS is equipped with an MMI (Man Machine Interface) from which it is possible to monitor and change the setting of parameters to adapt the ICAD 600A-TS and the corresponding ICMTS to the actual refrigeration application.

The setting of parameters is managed by means of the integrated ICAD 600A-TS MMI (see fig. 2 and fig. 3) and consists of:

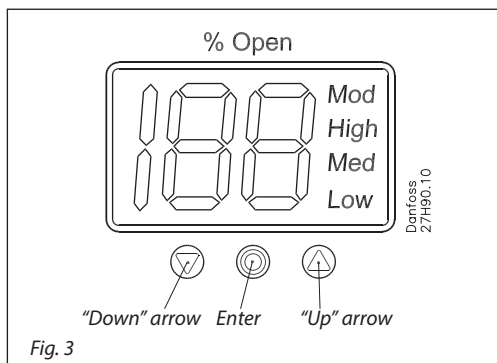

- "Down" arrow push button (fig. 2, pos. 1)
 - Decreases parameter number by 1 at each activation.
- "Up" arrow pushbutton (fig. 2, pos. 3)
 - Increases parameter number by 1 at each activation.
- Enter push button (fig. 2, pos. 2)
 - Gives access to the **Parameter list** by keeping the push button activated for 2 seconds. A **Parameter list** example is shown below (parameter **i08**, fig. 4).

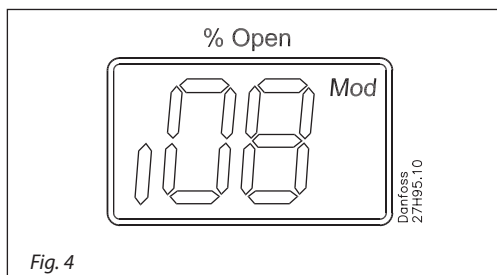

- Gives access to change a value once the Parameter list has been accessed
- Acknowledge and save change of value of a parameter.

- To exit from the **Parameter list** and return to the display of Opening Degree (OD), keep the Enter button activated for 2 seconds.
- Display (fig. 2, pos. 4)
 - The Opening Degree (OD) 0 - 100 % of the ICMTS valve is normally displayed. When the push buttons are not activated for 20 seconds, the display will return to OD (see fig. 5).

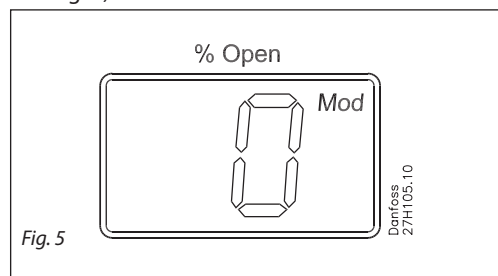

- Displays the parameter.
- Displays the actual value of a parameter.
- Displays the function status by means of text (fig. 2, pos. 4).
 - **Mod** represents that ICAD 600A-TS is positioning the ICMTS valve according to an analogue input signal (Current or Voltage).
 - **Low** represents that ICAD 600A-TSS is operating the ICMTS valve like an ON/OFF solenoid valve with low speed according to a digital input signal.
 - **Med** represents that ICAD 600A-TS is operating the ICMTS valve like an ON/OFF solenoid valve with medium speed according to a digital input signal.
 - **High** represents that ICAD 600A-TS is operating the ICMTS valve like an ON/OFF solenoid valve with high speed according to a digital input signal (see fig. 6).

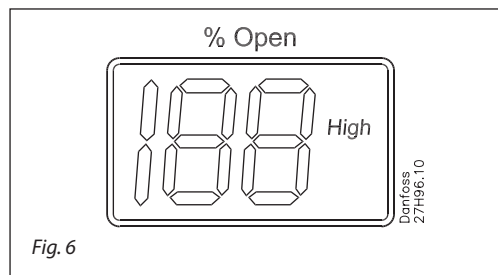

Alarms

Description	ICAD alarm text	Definition of event	Comments
No Valve type selected	A1	Alarm ON	At start-up A1 will be displayed
Controller fault	A2	Alarm ON	Internal fault inside electronics. Carry out: 1) Power OFF and Power ON If A2 still active. 2) Make a Reset to factory setting If A2 still active. Return ICAD to Danfoss
AI input error	A3	Alarm ON	Not active if j01 = 2, or j02 = 2 When j03 = 1 and AI A > 22 mA When j03 = 2 and AI A > 22 mA or AI A < 2 mA When j03 = 3 and AI A > 12 V When j03 = 4 and AI A > 12 V or AI A < 1 V
Low voltage of fail safe Supply	A4	Alarm ON	If 5 V < fail safe supply < 18 V. Enabled by j08
Check supply to ICAD	A5	Alarm ON	If supply voltage < 18 V
Calibration extended failed	A6	Alarm ON	Check valve type selected. Check presence of foreign body internally in ICMTS valve
Internal temperature alarm	A7	Alarm ON	Temperature for stepper motor component too high. Ventilate/lower ambient ICAD temperature
	A8	Alarm ON	Temperature for stepper motor component too high. Ventilate/lower ambient ICAD temperature.
Valve locked	A9	Alarm ON	Only active if i16 = 1 If the valve is locked in more than 15 seconds. ICMTS stopped and hold position A9 flashing in display A9 alarm can only be reset by Power OFF/ON of ICAD

If an alarm has been detected, the ICAD 600A-TS display (fig. 2) will alternate between showing Actual alarm and Present Opening Degree.

If more than one alarm is active at the same time, the alarm with the highest priority will take preference. **A1** has the highest priority, **A5** the lowest.

Any active alarm will activate the Common Digital Alarm Output (Normally Open).

All alarms will automatically reset themselves when they physically disappear.

Old alarms (alarms that have been active, but have physically disappeared again) can be found in parameter **j11**.

Data sheet | Motor operated valve, type ICMTS with actuator, type ICAD 600A-TS

Parameter list - Valid from: (i58:11, i59:36) and onwards

 The first parameter to be entered shall be: **i26**

Description	ICAD parameter	Min	Max	Factory Setting	Stored	Unit	Pass word	Comments
OD (Opening degree)	-	0	100			%	-	ICMTS valve Opening Degree is displayed during normal operation. Running display value (see i01 , i05).
Main Switch	i01	1	2	1	✓	-	No	Internal main switch 1: Normal operation 2: Manual operation. Valve Opening Degree will be flashing. With the down arrow and the up arrow push buttons the OD can be entered manually.
Mode	i02	1	2	1	✓	-	No	Operation mode 1: Modulating – ICMTS positioning according to Analog Input (see i03) 2: ON/OFF - operating the ICMTS valve like an ON/OFF solenoid valve controlled via Digital Input. See also i09 . 3: Neutralzone / 3 point control. Increase/Decrease Opening Degree by Digital Input. See fig. 9
AI signal	i03	1	4	2	✓	-	No	Type of AI signal from external controller 1: 0-20 mA 2: 4-20 mA 3: 0-10 V 4: 2-10 V
Speed In Modulating Mode Opening/closing speed In ON/OFF Mode Opening speed	i04	1	100	50/ 100	✓	-	No	Speed can be decreased. Max. speed is 100 % - Not active in manual operation (i01 = 2) If i26 = 1 - 3 then factory setting =100 If i26 = 4 - 9 then factory setting =50 If ICMTS is opening and (i04 <= 33) or ICMTS is closing and (i14 <= 33) => Low is displayed. If ICMTS is opening and (33 < i04 <= 66) or ICMTS is closing and (33 < i14 <= 66) => Med is displayed. If ICMTS is opening and (i04 >= 67) or ICMTS is closing and (i14 >= 67) => High is displayed"
Automatic calibration	i05	0	2	0		-	No	Not active before i26 has been operated. Always auto reset to 0. CA will flash in the display during calibration, if Enter push button has been activated for two seconds 0: No Calibration 1: Normal forced calibration - CA flashing slowly 2: Extended calibration – CA flashing rapidly"
AO signal	i06	0	2	2	✓	-	No	Type of AO signal for ICV valve position 0: No signal 1: 0-20 mA 2: 4-20 mA
Failsafe	i07	1	4	1	✓	-	No	Define condition at power cut and fail safe supply is installed. 1: Close valve 2: Open Valve 3: Maintain valve position 4: Go to OD given by i12 "
Fail safe supply	i08	0	1	0	✓		Yes	Fail safe supply connected and enable of A4 alarm: 0: No 1: Yes
DI function	i09	1	2	1	✓		No	Define function when DI is ON (short circuited DI terminals) when i02 = 2 1: Open ICMTS valve (DI = OFF => Close ICMTS valve) 2: Close ICMTS valve (DI = OFF => Open ICMTS valve)
Password	i10	0	199	0		-	-	Enter number to access password protected parameters: i26 Password = 11
Old Alarms	i11	A1	A99	-		-	No	Old alarms will be listed with the latest shown first. Alarm list can be reset by means of activating down arrow and up arrow at the same time for 2 seconds.
OD at power cut.	i12	0	100	50	✓		No	Only active if i07 = 4 If fail safe supply is connected and power cut occurs, the ICMTS will go to the specified OD.
Inverse operation	i13	0	1	0	✓		No	When i02 = 1 0: Increasing Analog Input signal => Increasing ICMTS Opening Degree 1: Increasing Analog Input signal => Decreasing ICMTS Opening Degree When i02 = 3 0: DI1 = ON, DI2 = OFF => Increasing ICMTS Opening Degree. DI1 = OFF, DI2 = ON => Decreasing ICMTS Opening Degree DI1 = DI2 = OFF => ICAD/ICMTS maintain current position DI1 = DI2 = ON => ICAD/ICMTS maintain current position 1: DI1 = ON, DI2 = OFF => Decreasing ICMTS Opening Degree DI1 = OFF, DI2 = ON => Increasing ICMTS Opening Degree DI1 = DI2 = OFF => ICAD/ICMTS maintain current position DI1 = DI2 = ON => ICAD/ICMTS maintain current position
In ON/OFF Mode Closing speed	i14	0	100	50/ 100	✓	-	No	See i04 . If i26 = 1 - 3 then factory setting = 100 If i26 = 4 - 9 then factory setting = 50
Manual set point	i15	0	100	0			No	When i01 = 2, i15 determine the start up value.

to be continued...

Data sheet | Motor operated valve, type ICMTS with actuator, type ICAD 600A-TS
Parameter list
(continued)

Description	ICAD parameter	Min	Max	Factory Setting	Stored	Unit	Pass word	Comments
Encoder operation	i16	0	1	0/1	✓		Yes	NB: Password protected. Password = 7 If i26 = 1 - 3 then factory setting = 0 If i26 = 4 - 6 then factory setting = 0 If i26 = 7 - 9 then factory setting = 1 0: Encoder disabled. Means ICAD operation as ICAD 600A-TS 1: Encoder enabled
Forced closing when ICMTS valve Opening Degree < 3%	i17	0	1	0	✓	-	No	Enable/Disable forced closing 0: When ICMTS valve Opening Degree < 3% it will be forced to close regardless of requested ICMTS valve Opening Degree 1: When ICMTS valve Opening Degree < 3% no forced to closing will take place
ICMTS configuration	i26	0	9	0	✓		Yes	NB: Password protected. Password = 11 0: No valve selected. Alarm A1 will become active. 1: ICMTS 20 with ICAD 600A-TS

Service

Description	ICAD Parameter	Min	Max	Factory Setting	Stored	Unit	Pass word	Comments
OD %	i50	0	100	-		%	-	ICMTS valve Opening Degree
AI [mA]	i51	0	100	-		mA	-	AI signal
AI [V]	i52	0	100	-		V	-	AI signal
AO [mA]	i53	0	100	-		mA	-	AO signal
DI	i54	0	1	-		-	-	DI signals. Depending of i02 If i02 = 2, one digits are shown. 0 : DI1 = OFF 1 : DI1 = ON If i02 = 3, two digits are shown. 00 : DI1 = OFF, DI2 = OFF 10 : DI1 = ON, DI2 = OFF 01 : DI1 = OFF, DI2 = ON 11 : DI1 = ON, DI2 = ON
DO Close	i55	0	1	-		-	-	DO Closed status. ON when OD < 3 %
DO Open	i56	0	1	-		-	-	DO Open status. ON when OD > 97 %
DO Alarm	i57	0	1	-		-	-	DO alarm status. ON when a Alarm is detected
Display mP SW ver.	i58	0	100	-		-	-	Software version for display microprocessor
Motor mP SW ver.	i59	0	100	-		-	-	Software version for motor microprocessor

Reset to factory setting:

1. Remove the power supply.
2. Activate down arrow and up arrow push buttons at the same time.
3. Connect the power supply.
4. Release down arrow and up arrow push buttons.
5. When the display on ICAD (fig. 2) is alternating between showing: **CA** and **A1** the factory resetting is complete.

ENGINEERING
TOMORROW

Danfoss