

Manual

Superheat Controller, type EKD 316



EKD 316 is a superheat controller for the stepper motor valve that can be used where there are requirements for accurate control of superheat in connection with refrigeration.

The controller and valve can be used where there are requirements for accurate control of superheat in connection with refrigeration. E.g.:

- Processing plant (water chillers)
- Cold store (air coolers)
- A/C plant
- Heat pumps
- Air conditioning

Advantages

- The superheat is regulated to the lowest possible value.
- The evaporator is charged optimally – even when there are great variations of load and suction pressure.
- Energy savings – the adaptive regulation of the refrigerant injection ensures optimum utilisation of the evaporator and thus a high suction pressure.

Main features

- Regulation of superheat
- MOP function
- ON/OFF input for start/stop of regulation
- Relay output to alarm
- MOD bus communication
- Safety features and
- Alarm indications

Contents

Applications	3
Function overview	3
Data	4
Accessories	4
Ordering	4
Dimensions.....	4
Connections	5
Configuration.....	6
Data communication	7
Installation	8
Installation sensors	9
Start of controller	10
Settings and checks to be made before start	10
Operation	11
Types of regulation	12
Manually operating the valve	13
Finding the optimum settings.....	14
If the superheat fluctuates.....	14
Troubleshooting	15
Alarms.....	15
Appendix I.....	16
- Menu survey	16
- Survey of functions	18
Appendix II.....	21
- General information to MODBUS communication via a PLC etc.	21
- EKD 316 – Parameter identification (modbus)	22
- Installation considerations	23
List of literature.....	23

Acronyms and abbreviations used in this manual:

LOC	Loss of charge indication
SH	Superheat
MOP	Maximum operating pressure
MSS	Minimum stable superheat
PNU	Parameter number
T _e	Saturated suction temperature
P _e	Evaporator pressure
S ₂	Evaporator temperature
S ₄	Evaporator outlet temperature
OD	Opening degree
EEV	Electronic expansion valve
ΔT _m	Temperature difference between media temperature and evaporating temperature

Applications

The following gives an idea of the application scope of the EKD 316 controller.

Water chiller using direct expansion

The most common application is water chillers using direct expansion. The regulation can be single loop using an AKS 32R pressure transmitter to measure evaporator pressure and an S2 sensor to measure superheated gas. If double loop regulation is used, the S4 sensor should be located at the water outlet pipe to measure the leaving water temperature. It is recommended to start with factory settings.

The application diagram shows the use of EKD 316 as a superheat controller, where temperature sensor AKS 21A and pressure transmitter AKS 32R have been shown as an example.

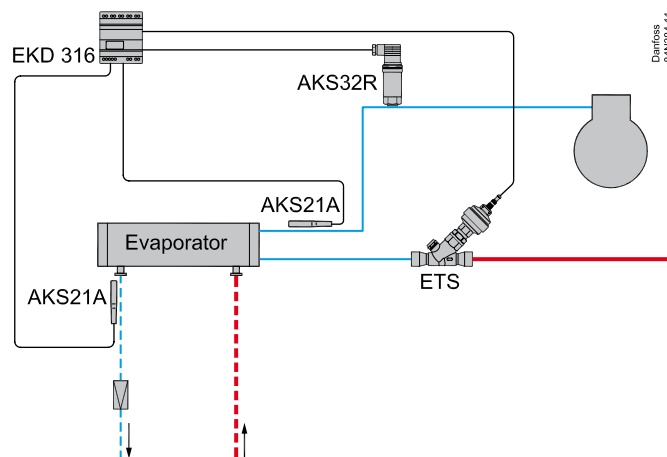

Danfoss
8449384.11

Function overview

Minimum Stable Superheat (MSS)

The controller will search for the minimum stable superheat between an upper and lower boundry. If the superheat has been stable for a period, the superheat reference is decreased. If the superheat becomes unstable, the reference is raised again. This process continues as long as the superheat is within the bounds set by the user. The purpose of this is to search for the lowest possible superheat that can be obtained while still maintaining a stable system. The superheat reference can also be fixed, in which case this function is disabled.

Maximum Operating Pressure (MOP)

In order to reduce the strain of the compressor, a maximum operating pressure can be set. If the pressure comes above this limit, the controller will control the valve to provide a lower pressure instead of a low superheat. The limit for this function is usually a fixed pressure, but it is possible to offset the limit temporarily.

Stand-alone function

EKD 316 is designed to operate in conjunction with a system master controller, which will control the EKD 316 via MODBUS or analog signal. It is however possible to use it in a standalone mode using one temperature and one pressure transducer.

Manual Control as a valve driver

The valve can be controlled manually by setting the desired operating degree using MODBUS. Alternatively, the controller may also be started and stopped externally using the analog signal 4 to 20 mA/0 to 10 V d.c., /1 to 5 V d.c.

Forced opening during startup

In some applications it is necessary to open the valve quickly when the compressor turns on to prevent suction pressure becoming too low. This is ensured by setting a fixed opening degree and a startup time for the controller. Note that this will give a fixed opening degree for the duration of the start time, regardless of the superheat value.

Relay

The relay for the alarm function is an alternating relay. In the event of an alarm, the relay will close, which may, for instance, be used for an alarm buzzer.

Data

Supply voltage	24 V a.c./d.c. +/-15% 50/60 Hz, 10 VA (the supply voltage is not galvanically separated from the input and output signals)	
Power consumption	Controller	5 VA
	ETS step motor	1.3 VA
Input signal *)Ri: mA: 400 ohm V: 50 kohm	Current signal *	4-20 mA or 0-20 mA
	Voltage signal *	0-10 V or 1-5 V
	Pressure transmitter	AKS 32R
	Digital input from external contact function	
Sensor input	2 pcs. Pt 1000 ohm	DI : < 800 ohm → ON DI : > 30 kohm → OFF
Alarm relay	1 pcs. SPDT	AC-1: 4 A (ohmic) AC-15: 3 A (inductive)
Step motor output	Pulsating 30 - 300 mA	
Data communication	Mounted with MODBUS data communication	
Environments	0 to +55°C, during operations	
	-40 to +70°C, during transport	
	20 - 80% Rh, not condensed	
	No shock influence/vibrations	
Enclosure	IP 20	
Weight	300 g	
Montage	DIN rail	
Operation	External display type EKA 164A or AK-ST via data communication and system unit	
Approvals	EU Low Voltage Directive and EMC demands re. CE-marking complied with. LVD-tested acc. to EN 60730-1 and EN 60730-2-9 EMC-tested acc. to EN50081-1 and EN 50082-2 	
Battery backup	If battery backup is used, the requirements for the battery are: 18-24 V d.c. See also page 12.	
Max. distance between controller and valve	30 m	

Ordering

Type	Function	Code no.
EKD 316	superheat controller (with terminals)	084B8040
EKA 164A	Display (with MODBUS communication)	084B8563
EKA 183A	Programming key	084B8582

Dimensions

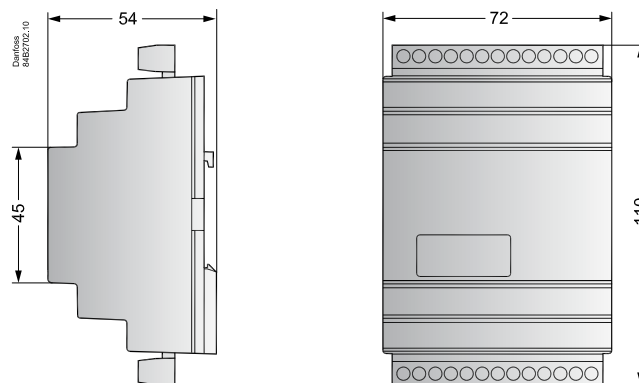

Accessories

Pressure transducer	Temperature sensor	External display	Programming key
AKS 32R, NSK 	AKS 21, AKS 11 	EKA 164A 	EKA 183A

Connections

Necessary connections

Terminals:

1-2	Supply voltage 24 V a.c./d.c.
3-4	Battery (the voltage will close the ETS valve if the controller loses its supply voltage). The battery voltage must not be connected from terminals 1 and 2.
5-8	Supply to stepper motor
9-13	Operation via data communication EITHER EKA 164A OR System unit + software. It is <u>important</u> that the installation of the data communication cable be done correctly. Cf. separate literature No. RC8AC...
20-21	Switch function for start/stop of regulation. ⚠ Note: If a switch is not connected, terminals 20 and 21 must be short circuited.

⚠ A dedicated transformer must be used.

Connections

ETS/KVS	
White	5
Black	6
Red	7
Green	8

ETS 6/ Saginomiya valves	
Orange	5
Yellow	6
Red	7
Black	8

Application-dependent connections

Superheat control

14-15	Pt 1000 sensor at evaporator outlet (S2)
15-16	Pt 1000 sensor for measuring air temperature (S4)
17-19	Pressure transmitter type AKS 32R ⚠ Note: The signal can not be shared with other controllers

Control of the valves opening degree with analog signal

21-22	Current signal or voltage signal from other regulation (Ext. Ref.)
24-26	Alarm relay There is connection between 24 and 26 in alarm situations.

⚠ Warning

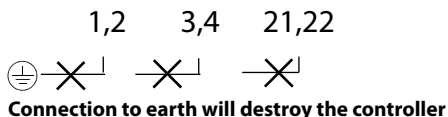

Any external connection with grounding could create a ground loop through a diode in the rectifier bridge which could destroy the power supply in EKD 316.

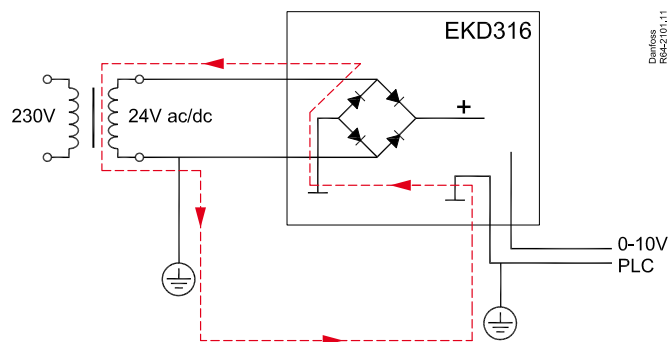

Configuration

Independent superheat regulation

The superheat in the evaporator is controlled by one pressure transmitter P and one temperature sensor S2. This can be done setting o61 = 2.

The expansion valve has a stepper motor of type ETS 6/ETS. Fitting the "S4" temperature sensor is optional, but the regulation is improved by an "inner loop control" when the sensor is fitted.

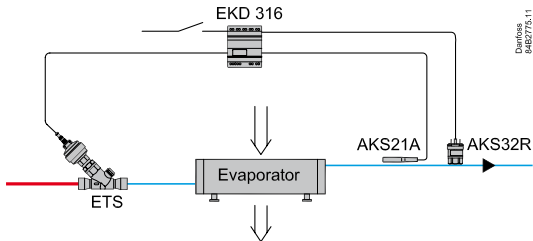

Function	Parameter	Value
Application Mode – superheat regulation	o61	2
Selection of normal control mode	056	1

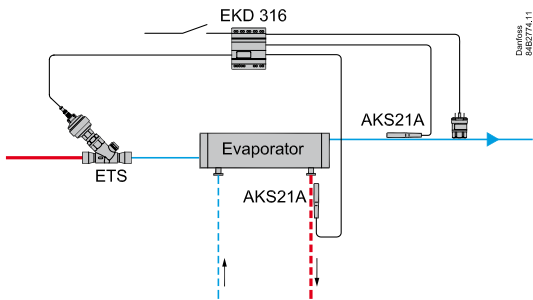

Function	Parameter	Value
Application Mode – superheat regulation	o61	2
Selection of inner loop control mode	056	2

We recommend this inner loop control application mode setting, if the superheating is to be regulated with precision. Here the S4 and T0 temperature are part of an inner loop control. The regulation algorithms require that a temperature sensor be fitted in the chilled medium.

The temperature sensor is connected to input "S4" and mounted in the chilled medium *after* the evaporator. (Danfoss calls a sensor S4 when it is mounted in the refrigerant after the evaporator).

External start/stop of regulation

The controller can be started and stopped externally via a contact function connected to input terminals 20 and 21. Regulation is stopped when the connection is interrupted. The function must be used when the compressor is stopped. The controller then closes the ETS valve so that the evaporator is not charged with refrigerant.

Battery

For safety reasons the liquid flow to the evaporator must be cut off if there is a power failure to the controller. As the ETS valve is provided with a stepper motor, it will remain open in such a situation. When mounting the battery backup, the valve will close in the event of a power cut.

Valve driver (Via Analog Signal)

This is where the controller receives signals from another controller, after which it controls the valve's opening degree. The signal can either be a current signal or a voltage signal. The valve can either be an ETS 6, ETS or KVS type. Details can be found on page 13.

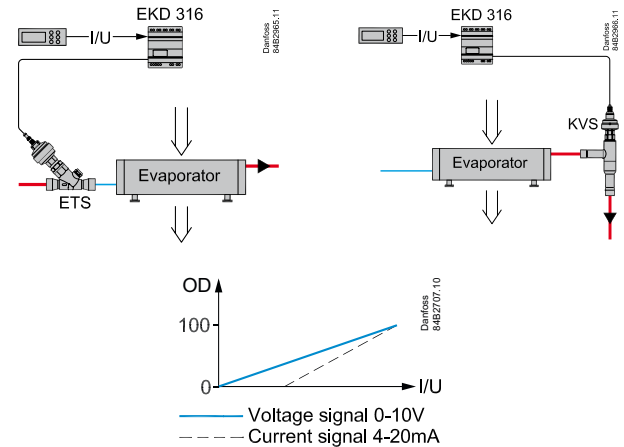

Parameter	Value	Function
o61	1	Application Mode - control via analog signal

Relays

The relay for the alarm function is an alternating relay. In the event of an alarm the relay will close to connect terminals 24 and 26. This can, for instance, be used for an alarm buzzer. When there is no alarm or the controller is off, terminals 24 and 25 are connected.

Parallel Evaporators with common suction line

Since the introduction of EEV, it has been observed the phenomena the so-called Sleeping Evaporators phenomena have been observed. This happens when the outlet of the evaporators has a common suction line.

This is seen when using the *Adaptive superheat Mode* in some of the controllers. What happens is that by controlling using the same superheat reference in both controllers, evaporator No. 1 might be controlling in the correct manner, but the EEV for evaporator No. 2 might be closed.

However, the measured superheat of controller No. 2 will be the same as No. 1 because both S2 sensors will measure the same temperature.

In other words, the open degree of the EEV integrates down to 0% but, the measured superheat complies with the reference valve.

One solution is to use the *Load-defined superheat Mode* in the controller because the measured superheat governs the opening degree of the connected EEV.

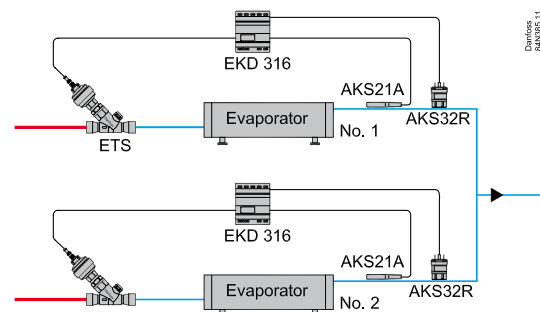

Data communication

Data communication with the EKD 316 is possible using one of the following two ways:

- 1. Via External display (EKA 164A)
- 2. Via standard MODBUS Device

Via external display (EKA 164A)

Use an external display to operate the controller. This must be done as follows:

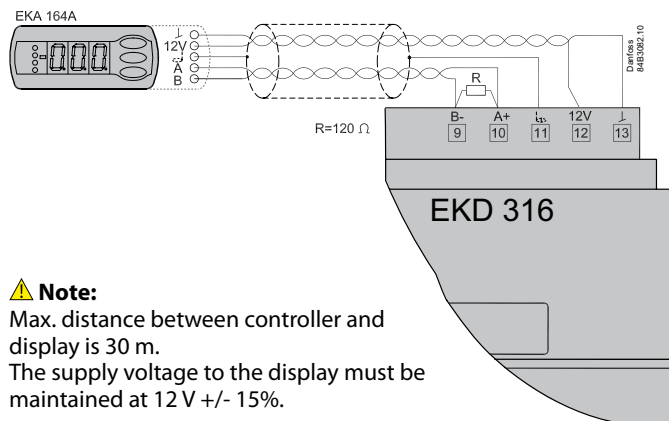

⚠ Note:

Max. distance between controller and display is 30 m.
The supply voltage to the display must be maintained at 12 V +/- 15%.

The values are shown in three digits, and with a setting you can determine whether the temperature is shown in °C or in °F. (Pressure in bar or psig.)

In order to change a setting, the upper and lower buttons will give you a higher or lower value depending on the button you are pushing. But before you change the value, you must have access to the menu. You obtain this by pushing the upper button for a couple of seconds – you will then enter the column with parameter codes. Find the parameter code you want to change and push the middle button until the value for the parameter is shown. When you have changed the value, save the new value by pushing once more on the middle button.

By pushing the middle button you go directly to the Main Switch setting (r12).

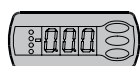

Example

Set a menu

1. Push the upper button until a parameter is shown
2. Push the upper or the lower button and find the parameter you want to change
3. Push the middle button and the value is shown
4. Push the upper or the lower button and select the new value
5. Push the middle button again to conclude the setting

Via standard MODBUS device

Communication direct to MODBUS RTU protocol.

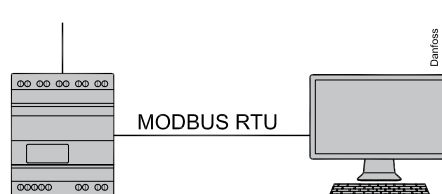

There are 3 different MODBUS baud rates available, which are 9,600 baud, 19,200 baud and 38,400 baud.
The default MODBUS baud rate is 19,200 baud.

A scan is performed once the EKD 316 controller is connected to the network. This will auto detect the baud rate used by the master and will automatically adjust to its setting. This process usually take a few seconds.

The only available fixed communication settings are 8 data bit, EVEN parity and 1 stop bit.

The default unit address is 240 which, can be changed using parameter "03 unit address".

EKD 316 can be operated from a PC that has AK-ST software loaded.

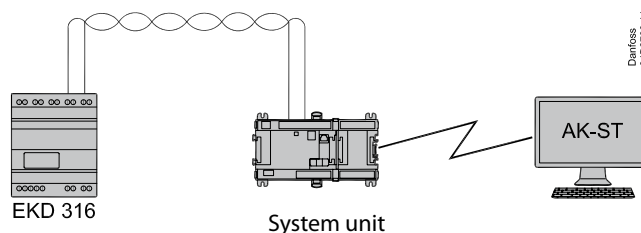

Communication from a third party controller or monitoring system

Settings and values can be read from the EKD 316 via MODBUS. However, the sensor values are from the local sensors and software has not been developed to receive values from another source.

A data list of EKD 316 parameters is provided in Appendix II.

Please note that it is not possible to connect the EKA 164A universal display in this configuration.

Installation

The EKD 316 is normally mounted on a DIN rail, and the necessary connections are shown in the diagram. If the sensor S4 is not used to measure air temperature in connection with thermostat function or as part of the controlling loop, then it is not necessary to connect the S4 sensor. The 18-24 V battery input at terminals 15 and 16 is not required if battery back-up is not needed.

Power supply considerations

The terminals 1 and 2 for the voltage supply are not isolated from the rest of the controller terminals. This means care should be taken when connecting two or more controllers to the same voltage supply. In the example below, the two controllers are connected to the same voltage supply and on the input side, terminals 21 (Analogue Input) are connected to each controller and similarly terminals 22 (GND).

This way of connecting the controllers can cause damage and should be avoided.

⚠ Note:

The same applies to other signal inputs e.g. terminals 2 and 4. See warning page 5.

Stepper motor output

After installation the following checks can be made to the connection between the EKD 316 controller and the stepper motor of the ETS 6/ETS valve.

With the power off, check that resistance between terminals 5 and 6 and terminals 7 and 8 is approximately 53 Ohms. Make slight allowances for cable resistance.

If resistance values differ from above, ensure that the cable is properly connected to the actuator of the ETS 6/ETS valve.

With the power on and parameter o18 set to 1, measure the phase current from terminal 5 (or 6) and terminal 7 (or 8) with a true RMS multimeter when the valve is operating. The valve can be driven from 0% to 100% and vice versa by changing the valve opening percentage in parameter o45. The phase current should be 70 mA rms when operating.

If this not the case and the cable connections are correct, then the stepper motor driver in the EKD 316 might be damaged.

Remember to set o18 back to 0 after checks.

If checks 1) and 2) are not correct, ensure that motor cable corrections are correct and the cable length is less than 30 meters.

Output relay contact

The contact of the alarm relay will be made when there is an alarm.

Battery back-up

A battery back-up can be connected to terminals 3 (+) and 4 (-). The voltage should be at least 18 V and this can be achieved by using two 9V 100 mAh batteries in series. The back-up voltage can also come from UPS giving 24 V.

If the controllers are operated by a common analogue signal as above, the voltage supply should be separate as shown below.

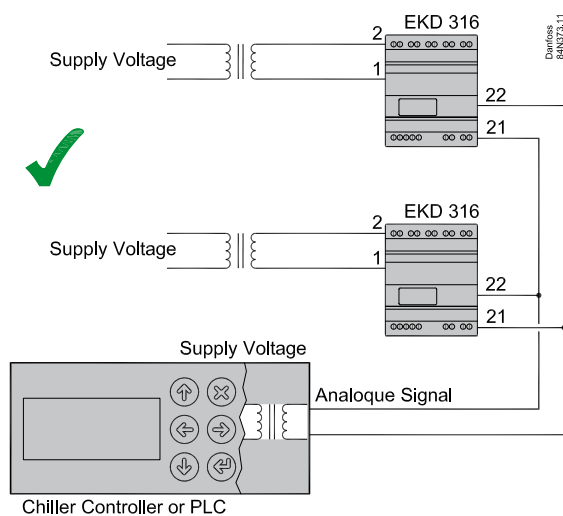
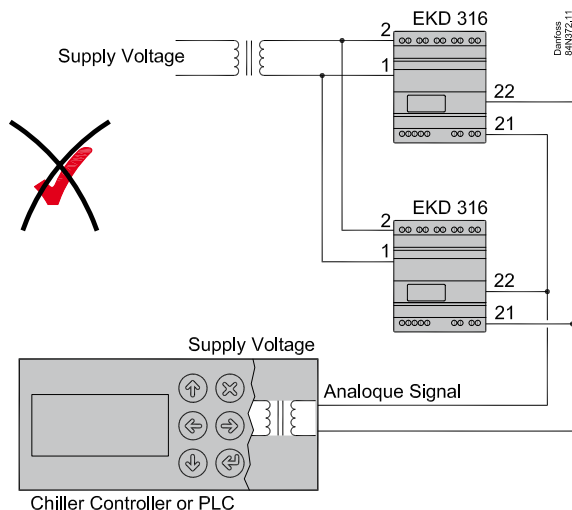

Installation sensors

S2 sensor positioning in the suction line

The position of the S2 sensor is crucial for an optimal control of the liquid injection.

The main purpose is to measure temperature of the superheated gas leaving the evaporator. In addition to this, the S2 sensor plays an important role detecting fast changes of superheat. Suction pressure is on the whole stable whereas the leaving gas condition is dependent on the temporary mixture of gas, liquid refrigerant and oil.

The sensor is also there to react quickly on liquid passing the evaporator, to avoid damage to the compressor.

An S2 sensor placed two-thirds of the way up a riser after an oil trap is where conditions are at their optimum, i.e. good mixture of gas, oil and liquid droplets, provided this is not more than 2 m from the evaporator.

If a horizontal pipe is the only option, the S2 sensor must be placed at least half a meter away from the evaporator.

S1 (Po pressure) is less critical but must be close to the actual suction pressure right after the evaporator.

If the measured value is 1-2 K lower than the actual value of Po right after the evaporator, it may cause the evaporator to flood. This is the case when the pressure transmitter is located in the machine room away from the evaporator. If the measured value is higher than the actual value of Po, the evaporator might be starved of liquid.

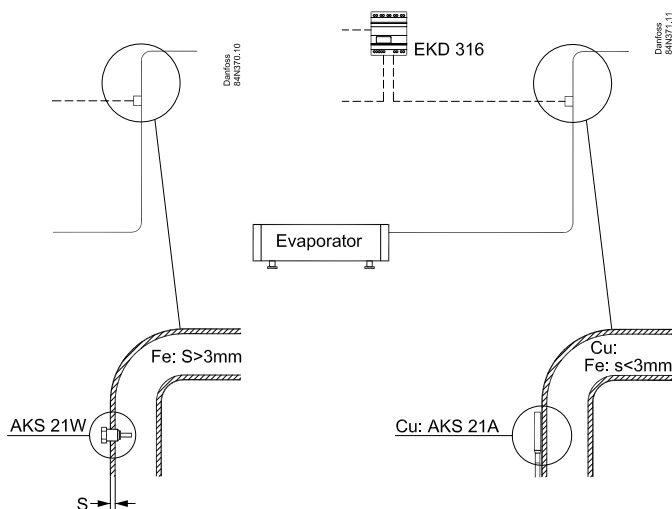

Choice of S2 sensor type

Surface sensor S2 *

Suction pipe of copper or on thin ($\leq 3\text{mm}$) steel pipe.

Remember to put on heat conducting paste and insulate the sensor.

Pocket sensor S2 **

Suction pipe of steel $\geq 3\text{mm}$

*) Pt1000 Ω Type AKS21 or AKS10

***) Pt1000 Ω Type AKS21W

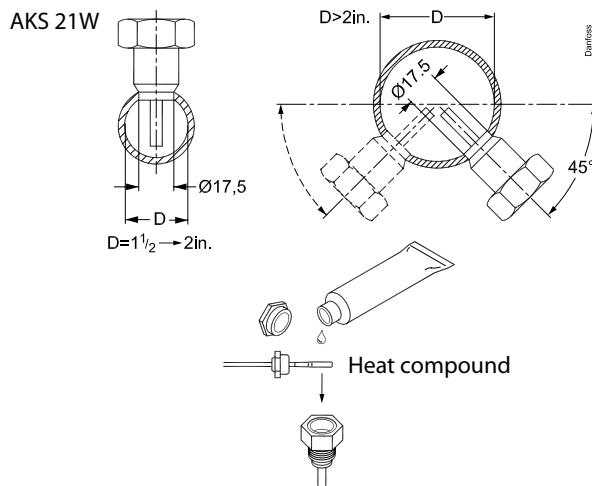

S2 sensor fixing on the suction pipe:

When the S2 sensor is fixed to the surface of the suction pipe, the angle of the sensor position will depend on the diameter of the pipe, as given in the following diagram:

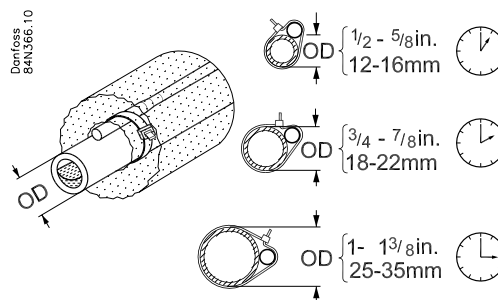

Start of controller

When the electric wires have been connected to the controller, the following points have to be attended to before the regulation starts:

1. Switch off the external ON/OFF switch that starts and stops the regulation.

2. Follow the menu survey in Appendix I, and set the various parameters to the required values.
3. Switch on the external switch, and regulation will start.
4. Follow the actual superheat on the display.

Settings and checks to be made before start

Basic settings

Before using the EKD 316 controller, there are settings that have to be made for each individual application. These are the refrigerant type, the pressure transducer range and the total number of steps for the ETS valve.

It is good practice and in some cases necessary to set the Main Switch r12 to OFF when making these changes.

If terminal 20-21 has been used as a start/stop regulation, then the interaction between internal and external start/stop function is, as shown on the following table:

Internal Start/stop	External start/stop (DI)		Regulation	Sensor monitoring	Configuration settings
Off	Off	=>	Off	No	Yes
Off	On	=>	Off	No	Yes
On	Off	=>	Off	Yes	No
On	On	=>	Yes	Yes	No

Refrigerant type

It is possible to choose from a list of 37 different refrigerants in the controller.

If the refrigerant is not found on the list, it is possible to enter the Antoine constants for the unlisted refrigerant using MODBUS communication and setting o30 to 13.

Refrigerant setting

Before refrigeration can be started, the refrigerant must be defined.

You can select the following refrigerants:

1 = R12	8 = R23	15 = R227	22 = R407B	30 = R417A
2 = R22	9 = R500	16 = R401	23 = R410A	31 = R422A
3 = R134a	10 = R503	17 = R507	24 = R170	32 = R413A
4 = R502	11 = R114	18 = R402A	25 = R290	33 = R422D
5 = R717	12 = R142b	19 = R404A	26 = R600	34 = 427A
6 = R13	13 = User-defined	20 = R407C	27 = R600a	35 = R438A
7 = R13b1	14 = R32	21 = R407A	28 = R744	R36 = Opteon XP10
			29 = R1270	37 = R407F

⚠ Warning: Wrong selection of refrigerant may cause damage to the compressor).

o30

ETS valve type

It is important to select the right valve type as listed under Valve definition.

The number of steps and steps/sec can also be set in the controller at addresses n37 and n38 respectively:

In practise, the EKD 316 display can only manage three digits.

Therefore the set value at address n37 is always 10 times greater, i.e. if n37 is set to 263 then the true value is 2630. The same applies to the n37 address in the MODBUS communication system.

Valve definition

0 = ETS 12½, ETS 25, KVS 15;
 1 = ETS 50, CCM 10, CCM 20, CCM 30;
 2 = ETS 100, CCM 40;
 3 = ETS 250, KVS 42;

4 = ETS 400;
 5 = user-defined;
 6 = Saginomiya UKV/SKV/VKV/PKV;
 7 = ETS 6;
 8 = CCMT 2, CCMT 4, CCMT 8

n03

Pressure transmitter

The range of the pressure transmitter can be set by entering the transmitter's minimum value at address o20 and maximum value at address o21. The pressure sensor input is set up by default to accept an AKS 32R pressure transducer. If another sensor is to be used, it is important to note that it needs to be a 5 V ratiometric type (10%-90% of supply voltage).

The default range for the typical pressure transducer is 0 to 16 bar. This can be changed by setting the minimum transducer pressure, "o20 MinTransPres", and the maximum transducer pressure, "o21 MaxTransPres", to the new values.

Working range for pressure transmitter

Depending on the application a pressure transmitter with a given working range is used.

For the range of (-1 to 12 bar), the min. value is set to -1 bar	o20	MinTransPres.
For the range of (-1 to 12 bar), the max. value is set to 12 bar	o21	MaxTransPres.

Operation

Superheat function

You may choose between two kinds of superheat regulation, either:

- Minimum stable superheat (MSS)
- Load-defined superheat

The regulation modes for controlling superheat

There are two different ways of controlling superheat, i.e. controlling according to the minimum stable superheat (MSS) and Load Defined superheat.

The parameter SH mode selects the controlling form where it can be set to MSS when set to 1, or Load Defined superheat when set to 2.

Minimum stable superheat (MSS)

The superheat control algorithm will attempt to regulate the superheat down to the lowest stable value between the minimum superheat setting, "Min SH" and the maximum superheat setting, "Max SH".

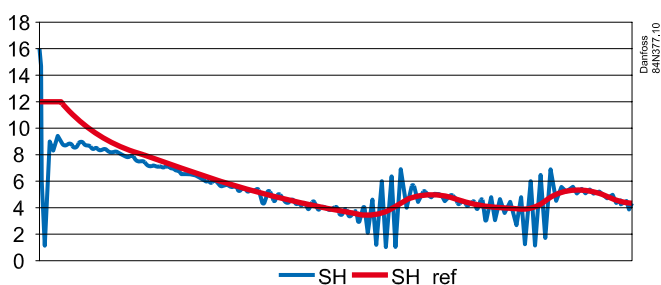

The superheat reference SH ref is adaptive and adjusted.

When using this form of control, there are three settings that have major affect on this mode of control.

Max SH – The maximum limit of SH ref.

Min SH – The minimum limit of SH ref. Care should be taken not to set this value too low in order to avoid flooding back into the compressor.

Stability – This factor determines how much instability can be accepted. Small values will cause the SH ref to increase if the slightest instability in SH is detected. Higher values will accept a higher degree of instability.

Function	Parameter	Default value
Superheat control -MSS	n21	1
Min Superheat Reference	n10	1 - 12 K
Max Superheat Reference	n09	2 - 15 K

Load define application

SH ref follows a defined curve as shown below. This curve is defined by three values: SH close SH max and SH min.

This form of regulation is similar to the thermostatic valve where the spring force can be adjusted to keep the SH (superheat) in the stable region to the right of the curve.

The advantage over the thermostatic valve is that there are three settings to define the operating curve.

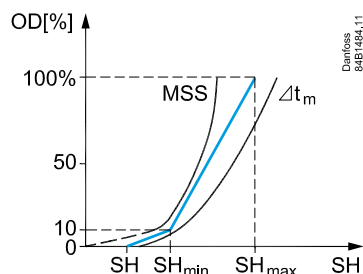

The reference follows a defined curve. This curve is defined by three values: the closing value, the min. value and the max. value. These three values must be selected in such a way that the curve is situated between the MSS curve and the curve for average temperature difference ΔT_m (temperature difference between media temperature and evaporating temperature). Setting example = n22=4, n10=6 and n09=10 K.

Function	Parameter	Value
Superheat control mode -2 = Load define	n21	2
Min Superheat Reference	n10	1 K
Max Superheat Reference	n09	2 K
Value of min. SH ref for loads under 10%	n22	Must be between Min and Max SH

Using the MOP

In order to reduce the current to the compressor it is possible to control the maximum operating pressure of the evaporator. Evaporator pressure exceeds the "MOP" limit, the valve opening degree is controlled by the MOP function which will keep the pressure below the "MOP" limit. This function takes precedence over the superheat control, so during MOP control the superheat is not controlled.

The MOP function (address n11) is active when it is set to values less than 200 bar (200 bar corresponds to off). The pressure value is converted to the corresponding temperature value and when the MOP is active, the controller will prevent the evaporating temperature T1 from exceeding this value.

If Maximum Operating suction Pressure MOP parameter n11 is reset from factory setting 20 to 1 bar (gauge) From the MOP i.e 1 bar point the OD increases slower and slower until the pressure reaches MOP + 0.5 i.e 1.5 bar. Subsequently the OD decreases rapidly as the pressure increases.

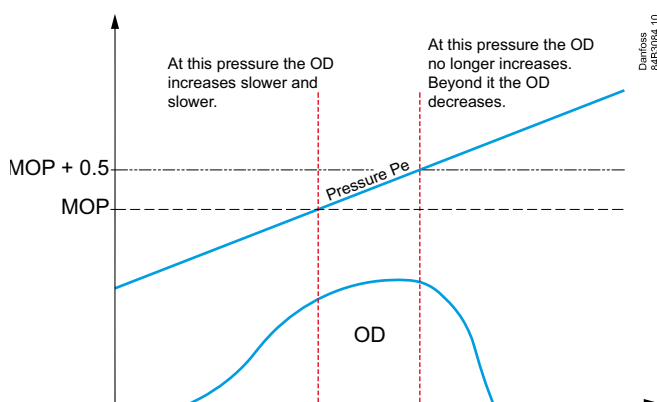

Function	Parameter	Value
Maximum operating pressure MOP	n11	0-200 bar

Types of regulation

As a general rule, do not use mode 2 (Load define application) if the effect is not evaluated by e.g. an OEM chiller manufacturer in a laboratory.

An incorrect setting will only make regulation poorer than the factory setting of mode 1.

Single Loop (address o56 Reg.type = 1)

The EKD 316 has the traditional PI controlling function with the Kp factor for Proportional Gain and Tn for Integration Time in seconds. This is also known as the Single loop control with only one PI block, as shown in the diagram below.

Double Loop (address o56 Reg.type = 2)

The controller can regulate the superheat using a double loop system. The so-called outer loop is really the same as in the single loop system except that the output of PI block is the reference for the inner loop.

The inner loop also has a PI block where the Proportional Gain factor is KpT0 and the Integration Time is TnT0.

The feedback of the inner loop is the temperature difference between media temperature S4 and S1. This value represents the load on the evaporator and large values will tend to increase the opening degree OD% of the valve.

Instability caused by too much Proportional Gain can be corrected by reducing to the value of the Kp factor.

This should be done by gradually reducing and observing the results before making further reductions.

If the superheat response is slow to change, it can be increased by reducing the value of the Integration Time Tn.

When tuning the superheat stability, it is good practice to have a fixed superheat reference by making *SH max the same as SH min*.

The tuning of the double loop is more complicated than the single loop and it is advisable not to change too many parameters at the same time. The starting point should be to use the following settings.

Function	Parameter	Value
Kp factor	n04	0.7
Tn sec	n05	120
KpT0	n20	3
TnT0 sec	n44	30

If the superheat is unstable, the KpT0 parameter should be slightly reduced. The value parameter Kp factor is not large so little is gained by reducing this parameter.

For details refer to the "Finding the optimum setting" section.

When to use Single or Double Loop

In most applications and especially air coolers, the single loop is the best option due to its simplicity and being easier to tune. In water chillers where the S4 sensor is located at the leaving water outlet, the double loop gives some advantage in terms of being less susceptible to compressor or fan step changes. In addition, it opens the valve quicker during startup. However, the double loop is less advantageous on air coolers because of the slower response to the media temperature changes.

⚠ Note:

The S4 sensor has to be connected when Reg. type = 2, otherwise an alarm sounds.

⚠ Note:

After o56 is changed, the controller must be switched off and powered up again.

Recommended control loop type and settings for some applications

From the experience of using single loop and double regulation, the following recommendations are given. These are only recommendations and the final choice is made by the end user.

Application	Reg. type	Kp factor	Tn sec	KpT0	TnT0 sec
	address n56	address n04	address n05	address n20	address n44
Air cooler	1 (Single loop)	3.0	120	0.4	-
Water chiller	2 (Double loop)	0.7	120	2.0	30

Manually operating the valve

There are two modes for operating the valve manually, and these are described in the following sections.

Operating the valve manually from the external display (or via MODBUS)

The opening degree of the ETS can be operated manually by setting parameter o18 to 1 and then setting parameter o45 to the required opening degree between 0% and 100%. Relay outputs can also be checked using parameter o18.

Manual control of outputs For service purposes the ETS 6/ETS output and alarm relay outputs can be forced, but only when regulation has been stopped. OFF: No override 1: Manual control via o45 is enabled 2: The alarm relay releases so that there is a connection between 24 and 25 (= alarm) 3: The alarm relay picks up so that there is a connection between 25 and 26 (= no alarm)	o18	Manual ctrl
Manual control of the valve's opening degree	045	0-100% valve OD

Operating the valve manually using an external analogue signal

The opening degree of the ETS 6/ETS valve can be operated manually with 0 to 20 mA or 4 to 20 mA or 0 to 10 V or 1 to 5 V external analogue signal connected to terminals 21 (-) and 22 (+) of the controller.

Controlling a valve with an analogue signal	061	Application mode 061=1
Input signal for external control of the valve's opening degree Only used if o61 is set to 1. Definition of the signal's range: 0: No signal 1: 0-20 mA 2: 4-20 mA 3: 0-10 V 4: 1-5 V (At the lower value the valve will be closed. At the upper value the valve will be fully open. There is a linear relationship between the signal and the opening degree. The height of the valve is not taken into account.)	o10	AI type

Finding the optimum settings

Details on the controller algorithm and settings

Kp factor (n04) and Kp min (n19)

The Proportional Gain is dependent on the value of the measured superheat SH relative to Reference superheat SH ref. The Proportional Gain has the following values relative to superheat SH:

If SH is more than 2.5K greater than SH ref, then Gain equals Kp factor.

If SH is within the range -0.5 and 2.5K from SH ref, then Gain equals Kp factor times Kp min.

The reason for this variable Gain is to provide stable superheat for values near the superheat reference.

⚠ Note:

The value of Gain does not change suddenly but gradually when SH gets close to SH ref.

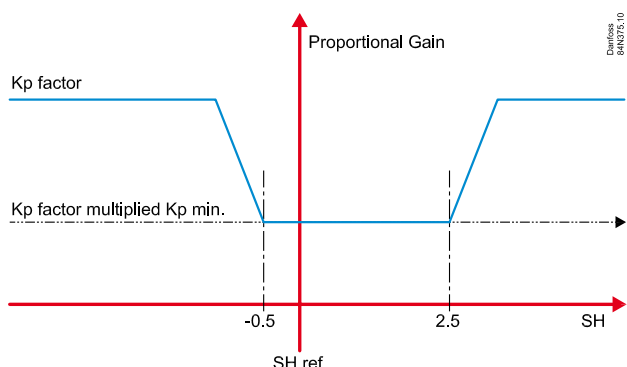

Initial "Kick start" startup

In general the valve opening degree is controlled by the measured value of the superheat SH. This means that during certain situations during startup, the valve will be slow to open due to the built-up of superheat from a small value. To prevent this from happening, the valve is given an initial opening degree dependent on the Kp factor, the measured superheat SH and SH close, as given in the following relationship:

$$\text{Initial OD\%} = k_p \text{ factor} * (\text{SH} - \text{SH close})$$

This procedure is not to be confused with the force opening of the valve given in the "Problems with startup" section.

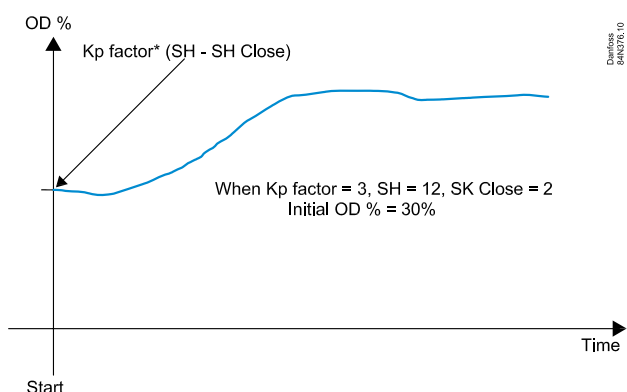

Problems with startup

Sometimes in one-to-one applications, the valve does not open sufficiently on startup, and troublesome low pressure trips may occur. This problem is typical when using the single loop control where only the SH controls the opening of the valve.

The *force opening of valve* function has been implemented in the EKD 316 controller. After startup, this function will provide a constant, set minimum opening degree during a set time period, regardless of the superheat value. The setting parameters are called *Start OD%* (n17) and *StartUp time* (n15).

Please observe that the *Start OD%* is a minimum value after startup and if the measured superheat (u21) produces a value greater than *Start OD%* then the value will be valve opening degree (u24) – see the diagram.

Forced Opening of Valve

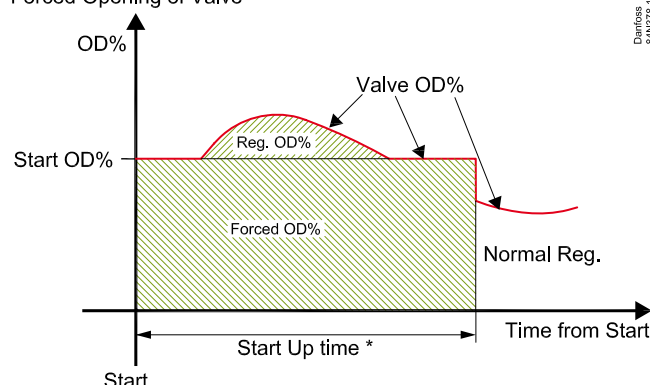

If the superheat fluctuates

When the refrigerating system has been made to work steadily, the controller's factory-set control parameters should in most cases provide a stable and relatively fast regulating system. If the system, however, fluctuates this may be due to the fact that superheat parameters that are too low have been selected. Before starting any adjustment of the factory settings check the S2 sensor location – see page 9:

If adaptive superheat has been selected (n21 = 1):

Adjust: n09, n10 and n18.

If load-defined superheat MSS has been selected (n21 = 2):

Adjust: n09, n10 and n22.

Alternatively it may be due to the fact that the set regulation parameters are not optimal.

If the time of oscillation is longer than the integration time:

($T_p > T_n$ (T_n is e.g. 240 seconds))

1. Increase T_n to 1.2 times T_p
2. Wait until the system is in balance again
3. If there is still oscillation, reduce K_p by e.g. 20%
4. Wait until the system is in balance
5. If it continues to oscillate, repeat 3 and 4

If the time of oscillation is shorter than the integration time:

($T_p < T_n$ (T_n is e.g. 240 seconds))

1. Reduce K_p by e.g. 20% of the scale reading
2. Wait until the system is in balance
3. If it continues to oscillate, repeat 1 and 2.

Troubleshooting

Symptom	Possible Cause	Remedy
Suction pressure too low	Pressure drop across the evaporator too high	
	Lack of subcooling ahead of expansion valve	Check refrigerant ahead of expansion valve. If the valve is placed much higher than condenser outlet, check pressure difference.
	Evaporator superheat too high	1. Check superheat performance, the settings SH min and SH max. 2. Check valve capacity. 3. Check that the maximum number of steps of valve is same as parameter n37.
	Pressure drop across the expansion valve less than valve is sized for	Check pressure drop across expansion valve. Replace with larger valve.
	Expansion valve too small	Check refrigeration system capacity and compare with expansion valve capacity. Replace with larger valve if necessary.
	Expansion valve block with foreign material	Remove valve and examine the orifice.
Liquid hammer in compressor	Evaporator wholly or partly iced up	De-ice evaporator
	Superheat of expansion valve too low	Increase the values of SH close and SH min.
	Superheat reference set too low	Increase the value of SH min
	The S2 sensor not in good contact with the suction line	Ensure that S2 sensor is secured on suction line. Insulate sensor.

Alarms

Symptom	Possible Cause	Fault Message	Remedy
All Light emitting diodes flashing		E24	S2 sensor fault
		E25	S4 sensor fault
	Analog input outside range.	E19	
	Pressure transmitter outside range.	E20	Check pressure transmitter, connections at 14-15 and pressure.
	No refrigerant selected	A11	Select refrigerant
Battery alarm	A44	Check the battery voltage is the nominal voltage.	
The controller can give the following messages	Error message	E1	Fault in controller
		E24	S2 Sensor error
		E25	S4 Sensor error
		E19	The input signal on terminals 21-22 is outside the range.
	Alarm message	E20	The input signal on terminals 17-19 is below minimum limit (PO signal)
		A11	No refrigerant has been selected
	Status codes	A44	Battery alarm (no voltage or too low voltage)
		S5	MOP
		S10	Refrigeration stopped r12=off
	non	Regulation, no fault	

⚠ Note:

- Only one alarm is displayed at a time in the controller display and are shown in the order given above. All alarms are displayed in the AKM system.
- The alarm E19 will only be active if address o10 is set to 1 or more.
- EKD 316 with change over relay (3 terminals 24-25-26)
- The battery alarm A44 is only active when battery alarm address A34 is set to ON.

Appendix I

Menu survey

SW = 1.32

Function	Parameter	Min.	Max.	Fac. setting	Application choice menu = 061	
					1	2
The menus from either column 1 or column 2 are shown						
Normal display						
During regulation the actual level of superheating is displayed. (If you would like to see the expansion valve's actual opening degree, press the bottom button for approx. one second.)	-		K	-		✓
During control with an analogue signal the opening degree is displayed.	-		%	-	✓	
Reference						
Units (0=°C+bar/1=°F+psig)	r05	0	1	0		✓
Correction of signal from S2	r09	-10.0 K	10.0 K	0.0		✓
Correction of signal from S4	r10	-10.0 K	10.0 K	0.0		✓
Start/stop of refrigeration	r12	Off/0	On/1	Off/0	✓	✓
Alarm						
Battery monitoring	A34	Off/0	On/1	Off/0	✓	✓
Regulating parameters						
Valve definition: 0 = ETS 12.5, ETS 25, KVS 15; 5 = user-defined; 1 = ETS 50, CCM 10, CCM 20, CCM 30; 6 = Saginomiya UKV/SKV/VKV/PKV; 2 = ETS 100, CCM 40; 3 = ETS 250, KVS 42; 7 = ETS 6; 8 = CCMT 2, CCMT 4, CCMT 8 4 = ETS 400;	n03	0	8	1	✓	✓
P: Amplification factor Kp o56 = 1; n04 = 2.0 o56 = 2; n04 = 0.7 (▲ Warning: Changes to n04 are lost when changing o56)	n04	0.5	20	2.0/0.7		✓
I: Integration time T	n05	30 s	600 s	120		✓
D: Differentiation time Td (0 = off)	n06	0 s	90 s	0		✓
Max. value of superheat reference	n09	2 K	15 K	10		✓
Min. value of superheat reference	n10	1 K	12 K	6		✓
MOP (max = off)	n11	0.0 bar	200 bar	20		✓
Signal reliability during startup. Safety time period. Should only be changed by trained staff	n15	0 sek.	90 sek	0		✓
Signal reliability during startup – opening degree's start value. Should only be changed by trained staff.	n17	0%	100%	0		✓
Stability factor for superheat control. Changes should only be made by trained staff	n18	0	10	5		✓
Damping of amplification around reference value Changes should only be made by trained staff	n19	0.0	1.0	0.3		✓
Amplification factor for superheat Changes should only be made by trained staff o56 = 1; n20 = 0.4 o56 = 2; n20 = 3.0 (▲ Warning: Changes to n20 are lost when changing o56)	n20	0.0	10.0	0.4/3.0		✓
Definition of superheat control mode 1 = MSS, 2 = LOADAP	n21	1	2	1		✓
Value of min. superheat reference for loads under 10%	n22	1 K	15 K	4		✓
Max. opening degree Changes should only be made by trained staff	n32	0 %	100 %	100		✓
Number of steps from 0-100% opening degree (only if n03 = 5 (User-defined)) ▲ Note: The display can only show three digits, but the setting value is four digits. Only the three most important are shown, i.e. a reading of e.g. 250 means a setting of 2500. (Automatic setting when valve is selected in n03).	n37	10 (100 stp)	990 (9990 stp)	262	✓	✓
Number of steps per second	n38	5 stp/s	300 stp/s	300	✓	✓
Start backlash (extra closing steps at 0% opening (in % of n37))	n39	0%	100%	10	✓	✓
Integration time for inner loop (TnT0)	n44	10 s	120 s	30		✓
Compensation for spindle play	n40	0 stp	100 stp	23 stp		

Miscellaneous						
Controller's address	o03	0	240	240	✓	✓
If the valve's opening degree should be controlled with an external signal, the signal is defined as: 0: no signal 1: 0-20 mA 2: 4-20 mA 3: 0-10 V 4: 1-5 V	o10	0	4	0	✓	
Manual control of outputs: OFF: no manual control 1: Manual control with "o45" enabled 2: Simulate Alarm off : connection between 24 and 25 3: Simulate Alarm on : connection between 24 and 26	o18	off/0	3	Off /0	✓	✓
Working range for pressure transmitter – min. value	o20	-1 bar	0 bar	-1.0		✓
Working range for pressure transmitter – max. value	o21	1 bar	200 bar	12.0		✓
Refrigerant setting 1 = R12 6 = R13 11 = R114 16 = R401A 21 = R407A 26 = R600 31 = R422A R36 = 2 = R22 7 = R13b1 12 = R142b 17 = R507 22 = R407B 27 = R600a 32 = R413A Opteon XP10 3 = R134a 8 = R23 13 = User def. 18 = R402A 23 = R410A 28 = R744 33 = R422D 37 = R407F 4 = R502 9 = R500 14 = R32 19 = R404A 24 = R170 29 = R1270 34 = 427A 5 = R717 10 = R503 15 = R227 20 = R407C 25 = R290 30 = R417A 35 = R438A	o30	0	37	0		✓
Manual control of the valve's opening degree. The function can only be operated if o18 has been set to "1". This function is only for manual operation. It must not be used for as a regulation function.	o45	0 %	100 %	0	✓	✓
Selection of control mode: 1=Normal 2 = With inner loop (S media temperature less T0)	o56	1	2	1		✓
Application mode. Menus blanked out so only the shaded menus are seen. See the two columns to the right. 1: Controlling a valve with an analogue signal 2: Superheat regulation	o61	1	2	2	1	2
Service						
Analog input (21-22)	u06			mA (V)	✓	
Read status of input DI (20-21)	u10			on/off	✓	✓
Temperature at S2 sensor	u20			°C		✓
Superheat	u21			K		✓
Superheat reference	u22			K		✓
Read valve's opening degree	u24			%	✓	✓
Read evaporating pressure	u25			bar		✓
Read evaporating temperature	u26			°C		✓
Temperature at S4 sensor	u27			°C		✓

Configuration settings (n03, n37, n38, n39, n40, o03, o30, o56 and o61) available only when regulation is stopped (r12=off).

Factory settings are indicated for standard unit (see code number, page 1). Other code number have customised settings.

Valve overview

n03	Valve type	n37	n38
0	ETS 12½, ETS 25, KVS 15	262	300
1	ETS 50, CCM 10, CCM 20, CCM30	262	300
2	ETS 100, CCM 40	353	300
3	ETS 250, KVS 42	381	300
4	ETS 400	381	300
5	-		
6	Saginomiya	24	30
7	ETS 6	24	30
8	CCMT 2, CCMT 4, CCMT 8	110	300

Survey of functions

Function	Parameter	Parameter by operation via data communication
Normal display		
The superheat is normally shown. The opening degree is displayed during manual operation or if the valve is under analogue control.		SH/OD%
Reference		Miscellaneous
Unit Here you select whether the controller is to indicate the temperature values in °C or in °F and pressure values in bar or psig. If indication in °F is selected, other temperature settings will also switch to Fahrenheit, either as absolute values or as delta. The combination of temperature unit and pressure unit is depicted to the right.	r05	Units (Menu = Misc.) 0: °C + bar 1: °F + psig
Correction of signal from S2 (Compensation possibility through long sensor cable).	r09	Adjust S2
Correction of signal from S4 (Compensation possibility through long sensor cable).	r10	Adjust S4
Start/stop of refrigeration With this setting, refrigeration can be started and stopped. Start/stop of refrigeration can also be accomplished with the external switch function. See also appendix 1.	r12	Main Switch
Alarm		Alarm setting
If there is an alarm, the LEDs on the front of the external display will flash if it is connected. The alarm relay in the controller is closed.		
Battery alarm Here it is defined whether the controller is to monitor the voltage from the battery backup. If there is low voltage, or no voltage, an alarm will be given	A34	Batt. alarm
Control parameters		Injection control
Valve definition 0 = ETS 12½, ETS 25, KVS 15; 1 = ETS 50, CCM 10, CCM 20, CCM 30; 2 = ETS 100, CCM 40; 3 = ETS 250, KVS 42; 4 = ETS 400; 5 = user-defined; 6 = Saginomiya UKV/SKV/VKV/PKV; 7 = ETS 6; 8 = CCMT 2, CCMT 4, CCMT 8	n03	Valve type
P: Amplification factor Kp If the Kp value is reduced the regulation becomes slower.	n04	Kp factor
I: Integration time Tn If the Tn value is increased the regulation becomes slower.	n05	Tn sec.
D: Differentiation time Td The D-setting can be cancelled by setting the value to min. (0).	n06	Td sec.
Max. value for the superheat reference	n09	Max SH
Min. value for the superheat reference ▲ Warning: Due to the risk of liquid flow, the setting should not be lower than approx. 2-4 K.	n10	Min SH
MOP ▲ Note: If no MOP function is required, select pos. Off. (A value of 200 corresponds to Off)	n11	MOP (bar)
Startup time for safety signal If the controller does not obtain a reliable signal within this period of time the controller will try to establish a stable signal in other ways. (A value that is too high may result in a flooded evaporator). The value should only be changed by specially-trained staff .	n15	Startup time
Signal safety during startup The control function uses the value as a start value for the valve's opening degree at each thermostat cut-in. By adaptive control the controller continuously calculates a new value. The value should only be changed by specially-trained staff.	n17	Start OD%
Stability factor for regulation of superheat With a higher value, the control function will allow a greater fluctuation of the superheat before the reference is changed. The value should only be changed by specially-trained staff.	n18	Stability

Survey and function (continued)

<p>Damping of amplification near reference value This setting damps the normal amplification Kp, but only just around the reference value. A setting of 0.5 will reduce the KP value by half. The value should only be changed by specially-trained staff.</p>	n19	Kp Min
<p>Amplification factor for the superheat This setting determines the valve's opening degree as a function of the change in evaporating pressure. An increase of the evaporating pressure will result in a reduced opening degree. When there is a drop-out on the low-pressure thermostat during startup, the value must be raised slightly. If there is pending during start-up, the value must be reduced slightly. The value should only be changed by specially-trained staff.</p>	n20	Kp T0
<p>Definition of superheat regulation (Ref. section "Operation") 1: Lowest permissible superheat (MSS). Adaptive regulation. 2: Load-defined superheat. The reference is established based on the line formed by the three points: n09, n10 and n22.</p>	n21	SH mode
<p>Value of min. superheat reference for loads under 10% (The value must be smaller than "n10").</p>	n22	SH Close
<p>Max. opening degree The valve's opening degree can be limited. The value is set in %.</p>	n32	ETS OD% Max
<p>Number of steps from 0% to 100% open (User-defined valve, n03 =5) (Automatic setting when valve is selected in n03).</p>	n37	Max. steps (100 to 6000 step)
<p>Spindle stroke speed (number of steps per second) (Automatic setting when valve is selected in n03).</p>	n38	Steps/sec (5 to 300 step/sec)
<p>Integration time for the inner loop gain Used only when o56 = 2 The value should only be changed by specially-trained staff.</p>	n44	TnT0 sec
<p>Miscellaneous</p> <p>Address/data communication The controller must always have an address. The factory-set address is 240. When an external display is connected, the display itself will find the address of the controller so that communication can take place.</p> <p>⚠ Note: A display and a system unit must not be connected at the same time. The display will not be able to communicate in this situation.</p> <p>If the controller is to be part of a network with other controllers and a system unit, the controller's address must be within the range 1 to 200. This address must EITHER be set via a display before it is connected to the data communication and a scan of the network is performed OR the network is connected and a scan is performed. The address is then set afterwards. A new scan is performed so that the new address is known.</p> <p>Requirements for the installation and data communication cable are discussed in the separate document no. "RC8AC".</p>		<p>Miscellaneous</p> <p>The controller can be operated via the system unit and AK service tool.</p> <p>It cannot be operated via AKM type system software.</p>
	o03	Unit addr. The address is set between 0 and 200. (When the address is set, the system the system unit's scan function should be activated)
<p>Application mode 1: The controller receives signals from another controller and must control the valve's opening degree. 2: Superheat regulation.</p>	o61	Appl. mode
<p>Input signal for external control of the valve's opening degree Only used if o61 is set to 1. Definition of the signal's range. 0: No signal 1: 0-20 mA 2: 4-20 mA 3: 0-10 V 4: 1-5 V (At the lower value the valve will be closed. At the upper value the value will be fully open. There is a linear relationship between the signal and the opening degree. The height of the valve is not taken into account.)</p>	o10	AI type

Appendix II

General information to MODBUS communication via a PLC etc.

- * Baudrate : 19200
- * EKD Address : 240
- * Polarity A-A and B-B
- * Termination with 120 ohm resistor

Some parameters have what is called a "config lock". This means that they can only be changed when the main switch of the EKD is set to OFF (r12 = 0). This applies for instance to the type of refrigerant (o30). So if you want to change the refrigerant, the main switch (r12) must first be set to 0, then the refrigerant type (o30) can be changed.

Example:

EKD 316 as simple ETS valve driver function with the following settings:

- PNU 117 [0] r12 Main switch = 0
- PNU 2075 [1] o18 Manual mode
- PNU 2064 [OD%] o45 Manual ETS OD% (replace 0-10V signal)
- PNU 3032 [262] n37 Max. steps 2620
- PNU 3033 [250] n38 Steps pr. sec 250

- EKD 316 address : 240
- PNU 2064 will go back to 0% at power off as the only one

The following parameters require the main switch to be OFF:

n03	Valve type
n37	Max steps
n38	Max steps/sec
o03	Unit address
o30	Refrigerant
o56	Regulation type
o61	Application mode

Please refer to the manual for descriptions of these parameters.

It should be possible to change all other parameters while the unit is running (regulation parameters etc.).

EKD 316 – Parameter identification (modbus)

Explanations:

- Parameter** – The parameter name and abbreviation
- PNU** – The Parameter Number. **⚠ Note: This is equivalent to the modbus register number (modbus address + 1)**
- R/W** – R means read only, RW means it can be changed
- Config lock** – If the parameter is config locked it means that the value can only be changed when the main switch is off
- Min** – The minimum value of the parameter
- Max** – The maximum value of the parameter
- Default** – The default value of the parameter (factory setting)
- Actual value** – Values are read/written as 16 bit integer values without decimals. This is the default value as read via modbus
- Scale** – This shows the scaling factor of the value. *1 means that there is no scaling. *10 means that the read value is 10 times larger than the actual value.

Parameter	PNU	R/W	Config lock	Min	Max	Default	Actual value	Scale
Injection control (1)								
n04 Kp factor	3003	R/W		0.5	20.0	2.0	20	*10
n05 Tn seconds	3004	R/W		30	600	120	120	*1
n06 Td seconds	3005	R/W		0	90	0	0	*1
n09 Max SH	3015	R/W		2.0	15.0	10.0	100	*10
n10 Min SH	3021	R/W		1.0	12.0	6.0	60	*10
n11 MOP	3013	R/W		0.0	200.0	20.0	200	*10
n15 Start time	3017	R/W		1	90	0	0	*1
n17 MinOdAtStart	3012	R/W		0	100	0	0	*1
n18 Stability	3014	R/W		0	10	5	5	*1
n19 Kp min.	3024	R/W		0.0	1.0	0.3	3	*10
n20 Kp T0	3025	R/W		0.0	10.0	0.4	4	*10
n21 SH mode	3026	R/W		1	2	1	1	*1
n22 SH close	3027	R/W		1.0	15.0	4.0	40	*10
n32 ETS OD% Max	3023	R/W		0	100	100	100	*1
n44 TnT0 sec.	3039	R/W		10	120	30	30	*1
o56 Reg. type	2076	R/W	x	1	2	1	1	*1
Motor(2)								
n37 Max steps	3032	R/W	x	10	999	262	262	*1
n38 Max StepsSec	3033	R/W	x	5	300	300	300	*1
n39 Start backlash	3034	R/W	x	0	100	10	10	*1
n40 Backlash	3035	R/W	x	0	100	23	23	*1
n03 Valve type	3002	R/W	x	0	8	1	1	*1
Alarm settings (3)								
A34 Battery low	10035	R/W		0	1	0	0	*1
Miscellaneous (11)								
r05 Temp.unit	105	R/W		0	1	0	0	*1
r09 Adjust S2	113	R/W		-10.0	10.0	0.0	0	x10
r10 Adjust S3	114	R/W		-10.0	10.0	0.0	0	x10
o20 MinTransPres	2034	R/W		-1.0	0.0	0.0	0	*10
o21 MaxTransPres	2033	R/W		1.0	200.0	12.0	120	*10
o30 Refrigerant	2551	R/W	x	0	37	0	0	*1
o18 Manual ctrl.	2075	R/W		0	3	0	0	*1
o45 Manual OD%	2064	R/W		0	100	0	0	*1
Service (12)								
o61 Appl.mode	2077	R/W	x	1	2	2	2	*1
u10 DI1 status	2002	R		0	1	0	0	*1
u06 Analog input	2504	R		0.0	30.0	0.0	0.0	*10
--- AL/Light rel	2509	R		0	1	0	0	*1
--- Reset alarm	2046	R/W		0	1	0	0	*1
--- Rfg.Fac.A1	2548	R/W		8000	12000	10428	10428	*1
--- Rfg.Fac.A2	2549	R/W		-4000	-1000	-2255	-2255	*1
--- Rfg.Fac.A3	2550	R/W		1000	3000	2557	2557	*1
Alarms (13)								
--- Standby	20000	R		0	1	0	0	*1
--- EKC Error	20001	R		0	1	0	0	*1
--- S2 Error	20002	R		0	1	0	0	*1
--- S3 Error	20003	R		0	1	0	0	*1
--- P _e inp.error	20004	R		0	1	0	0	*1
--- AI inp.error	20005	R		0	1	0	0	*1
--- No Rfg. Sel.	20006	R		0	1	0	0	*1
--- Valve error	20007	R		0	1	0	0	*1
--- Battery low	20008	R		0	1	0	0	*1
Danfoss only (14)								
o03 Unit addr.	2008	R/W	x	1	240	240	240	*1
No text (15)								
r12 Main switch	117	R/W		0	1	0	0	*1
u20 S2 temp.	2537	R		-200.0	200.0	0.0	0.0	*10
u21 Superheat	2536	R		0.0	100.0	0.0	0.0	*10
u22 SuperheatRef	2535	R		0.0	100.0	0.0	0.0	*10
u24 Opening %	2542	R		0	100	0	0	*1
u25 EvapPress P _e	2543	R		-200.0	200.0	0.0	0.0	*10
u26 EvapTemp T _e	2544	R		-200.0	200.0	0.0	0.0	*10
u27 Temp. S3	2545	R		-200.0	200.0	0.0	0.0	*10
--- EKC State	2007	R		0	100	0	0	*1

Installation considerations

Accidental damage, poor installation, or site conditions can give rise to malfunctions of the control system, and ultimately lead to a plant breakdown.

Every possible safeguard is incorporated into our products to prevent this. However, an incorrect installation, for example, could still present problems. Electronic controls are no substitute for normal, good engineering practice.

Danfoss will not be responsible for any goods, or plant components, damaged as a result of the above defects. It is the installer's responsibility to check the installation thoroughly, and to fit the necessary safety devices.

Particular attention is drawn to the need for a "force closing" signal to controllers in the event of compressor stoppage, and to the requirement for suction line accumulators.

Your local Danfoss agent will be pleased to assist with further advice, etc.

List of literature

www.danfoss.com

Click: "Technical literature" in the left bar

Click: Refrigeration and Air Conditioning " > Technical literature"

Paste or write the no. in the box " Literature No."

- Catalogue **RK0YG**
- ETS valves, technical brochure **DKRCC.PD.VD**
- Installation guide for data communication **RC8AC**

Your local Danfoss agent will be pleased to assist with further advice, etc.