

1. M12 connector
2. Glass seal
3. AST motor housing
4. Stepper motor
5. Bearing
6. Spindle
7. Top Nut
8. Valve piston
9. Valve seat
10. Valve cone

ETS 50 & 100

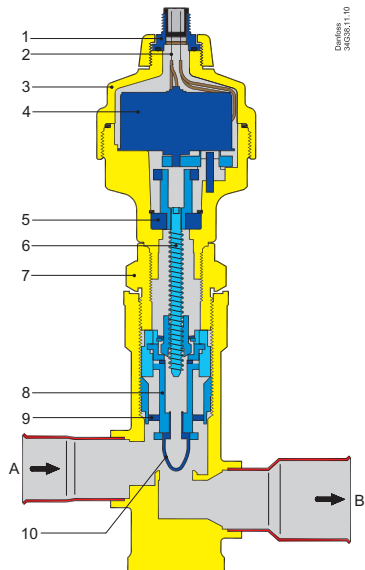

1. M12 connector
2. Glass seal
3. AST motor housing
4. Stepper motor
5. Bearing
6. Spindle
7. Top Nut
8. Valve piston
9. Sight glass with indicator
10. Valve seat
11. Valve cone

ETS 250 & 400

