



Quick Guide

VLT[®] HVAC Basic Drive FC 101



Contents

1 Quick Guide	2
1.1 Safety	2
1.1.1 Warnings	2
1.1.2 Safety Instructions	2
1.2 Introduction	3
1.2.1 Available Literature	3
1.2.2 Approvals	3
1.2.3 IT Line Power	3
1.2.4 Avoid Unintended Start	4
1.2.5 Disposal Instruction	4
1.3 Installation	4
1.3.1 Before Starting Repair Work	4
1.3.2 Dimensions	5
1.3.3 Electrical Installation in General	7
1.3.4 Connecting to Line Power and Motor	8
1.3.5 Fuses and Circuit Breakers	16
1.3.6 EMC-compatible Electrical Installation	18
1.3.7 Control Terminals	19
1.4 Programming	21
1.4.1 Programming with the Local Control Panel (LCP)	21
1.4.2 The Start-up Wizard for Open-loop Applications	22
1.4.3 Main menu structure	32
1.5 Acoustic Noise or Vibration	34
1.6 Warnings and Alarms	34
1.7 General Specifications	36
1.7.1 Line Power Supply 3x200–240 V AC	36
1.7.2 Line Power Supply 3x380–480 V AC	37
1.7.3 Line Power Supply 3x525–600 V AC	41
1.8 Special Conditions	46
1.8.1 Derating for Ambient Temperature and Switching Frequency	46
1.8.2 Derating for Low Air Pressure	46
1.9 Options for VLT [®] HVAC Basic Drive FC 101	46
1.10 MCT 10 Support	46

1 Quick Guide

1.1 Safety

1.1.1 Warnings

⚠ WARNING

High Voltage Warning

The voltage of the adjustable frequency drive is dangerous whenever it is connected to line power. Incorrect installation of the motor or adjustable frequency drive may cause damage to the equipment, serious injury or death. Consequently, it is essential to comply with the instructions in this manual as well as local and national rules and safety regulations.

⚠ WARNING

DISCHARGE TIME!

Adjustable frequency drives contain DC link capacitors that can remain charged even when the adjustable frequency drive is not powered. To avoid electrical hazards, disconnect AC line power, any permanent magnet type motors, and any remote DC link power supplies, including battery backups, UPS and DC link connections to other adjustable frequency drives. Wait for the capacitors to fully discharge before performing any service or repair work. The wait time required is listed in the *Discharge Time* table. Failure to wait for the specified period of time after power has been removed to do service or repair could result in death or serious injury.

Voltage [V]	Power range hp [kW]	Minimum waiting time [min]
3x200	0.34–5 [0.25–3.7]	4
3x200	7.5–15 [5.5–11]	15
3x400	0.50–10 [0.37–7.5]	4
3x400	15–125 [11–90]	15
3x600	3–10 [2.2–7.5]	4
3x600	15–125 [11–90]	15

Table 1.1 Discharge Time

CAUTION

Leakage Current:

The ground leakage current from the adjustable frequency drive exceeds 3.5 mA. According to IEC 61800-5-1, a reinforced Protective Ground connection must be ensured with a min. 10 mm² Cu or an additional PE wire – with the same cable cross-section as the Line Power wiring – must be terminated separately.

Residual Current Device:

This product can cause a DC current in the protective conductor. Where a residual current device (RCD) is used for extra protection, only an RCD of Type B (time delayed) shall be used on the supply side of this product.

Protective grounding of the adjustable frequency drive and the use of RCDs must always follow national and local regulations.

Motor thermal protection

Motor overload protection is possible by setting 1-90 Motor Thermal Protection to [4] ETR trip.

⚠ WARNING

Installation at high altitudes

For altitudes above 6,600 feet [2 km], contact Danfoss.

1.1.2 Safety Instructions

- Make sure the adjustable frequency drive is properly grounded.
- Do not remove AC line input connections, motor connections or other power connections while the adjustable frequency drive is connected to line power.
- Protect users against supply voltage.
- Protect the motor against overloading according to national and local regulations.
- The ground leakage current exceeds 3.5 mA.
- The [Off/Reset] key is not a safety switch. It does not disconnect the adjustable frequency drive from line power.

1.2 Introduction

1.2.1 Available Literature

This Quick Guide contains basic information necessary for installing and running the adjustable frequency drive. If more information is needed, literature can be found on the enclosed CD.

1.2.2 Approvals



Certification		IP20	IP54
EC Declaration of Conformity		✓	✓
UL-listed		✓	-
C-tick		✓	✓

Table 1.2 Approvals

The adjustable frequency drive complies with UL508C thermal memory retention requirements. For more information, refer to the section *Motor Thermal Protection* in the *Design Guide*.

1.2.3 IT Line Power

CAUTION

IT Line Power

Installation on isolated line power source, that is, IT line power.

Max. supply voltage allowed when connected to line power: 440 V (3x380–480 V units).

On IP20 200–240 V 0.34–15 hp [0.25–11 kW] and 380–480 V IP20 0.5–30 hp [0.37–22 kW], open the RFI switch by removing the screw on the side of the adjustable frequency drive when at IT grid.

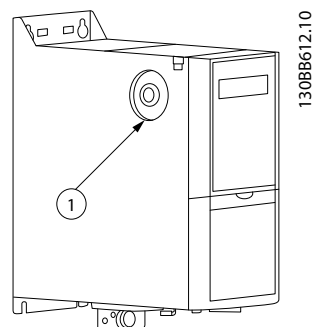

Figure 1.1 IP20 200–240 V 0.34–15 hp [0.25–11 kW], IP20 0.5–30 hp [0.37–22 kW] 380–480 V.

1	EMC screw
---	-----------

Table 1.3 Legend to Figure 1.1

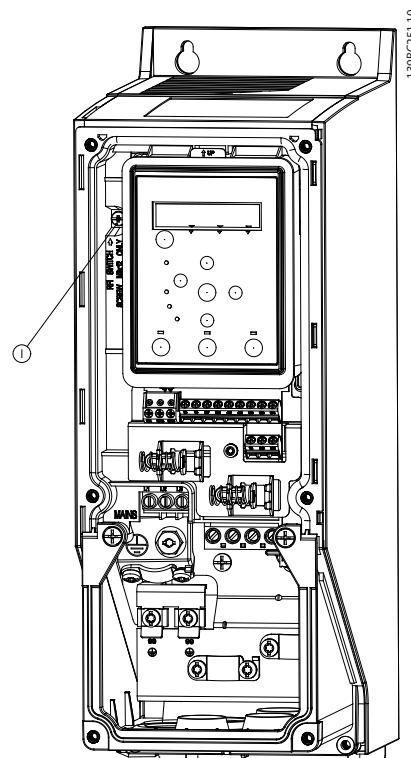

Figure 1.2 IP54 400 V 1–25 hp [0.75–18.5 kW]

1	EMC screw
---	-----------

Table 1.4 Legend to Figure 1.2

On all units, set *14-50 RFI Filter* to [0] Off when operating in IT line power.

CAUTION

If reinserted, only use M3x12 screws.

1.2.4 Avoid Unintended Start

While the adjustable frequency drive is connected to line power, the motor can be started/stopped using digital commands, bus commands, references or via the LCP or LOP.

- Disconnect the adjustable frequency drive from line power whenever personal safety considerations make it necessary to avoid unintended start of any motors.
- To avoid unintended start, always press [Off/Reset] before changing parameters.

1.2.5 Disposal Instruction

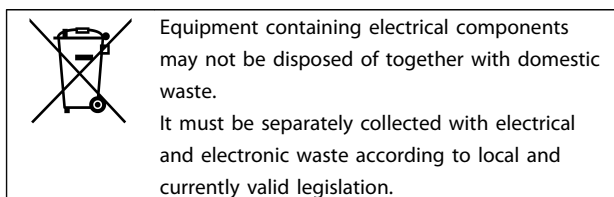

1.3 Installation

1.3.1 Before Starting Repair Work

1. Disconnect from line power (and external DC supply, if present).
2. Wait as stated in *Table 1.1* for discharge of the DC link.
3. Remove motor cable.

1.3.2 Dimensions

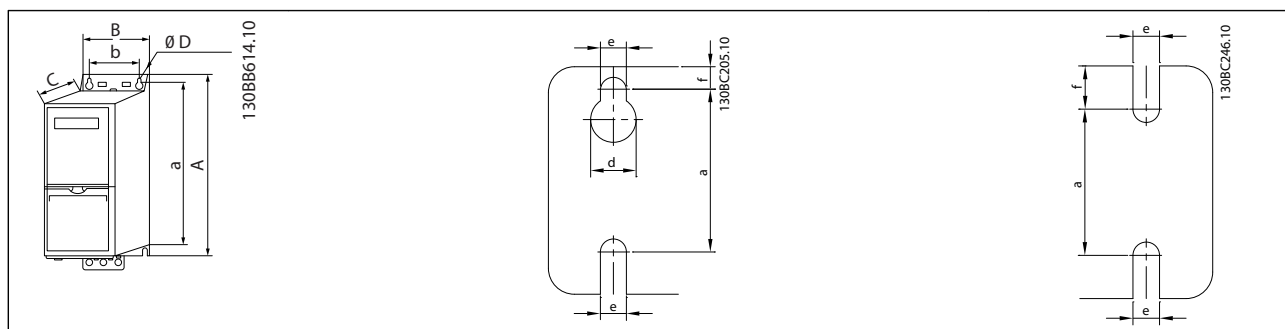

Enclosure		Power (hp [kW])			Height (in [mm])			Width (in [mm])		Depth (in [mm])	Mounting hole (in [mm])			Max. Weight
Frame	IP Class	3x 200-240 V	3x 380-480 V	3x 525-600 V	A	A ¹	a	B	b	C	d	e	f	lb [kg]
H1	IP20	0.34-2 [0.25-1.5]	0.5-2 [0.37-1.5]		7.68 [195]	10.75 [273]	7.21 [183]	2.95 [75]	2.21 [56]	6.61 [168]	0.35 [9]	0.18 [4.5]	0.21 [5.3]	4.63 [2.1]
H2	IP20	3 [2.2]	3-5 [2.2-4.0]		8.94 [227]	11.93 [303]	8.35 [212]	125 [90]	2.56 [65]	7.48 [190]	0.43 [11]	0.59 [5.5]	0.29 [7.4]	7.5 [3.4]
H3	IP20	5 [3.7]	7.5-10 [5.5-7.5]		8.86 [255]	12.95 [329]	9.45 [240]	3.94 [100]	2.91 [74]	8.11 [206]	15 [11]	0.59 [5.5]	0.32 [8.1]	9.92 [4.5]
H4	IP20	7.5-10 [5.5-7.5]	15-20 [11-15]		11.65 [296]	14.13 [359]	10.83 [275]	5.32 [135]	4.13 [105]	9.49 [241]	0.5 [12.6]	0.28 [7]	0.33 [8.4]	17.42 [7.9]
H5	IP20	15 [11]	25-30 [18.5-22]		13.15 [334]	15.83 [402]	12.36 [314]	5.91 [150]	4.73 [120]	8.86 [255]	0.5 [12.6]	0.28 [7]	0.34 [8.5]	20.94 [9.5]
H6	IP20	20-25 [15-18.5]	40-60 [30-45]	25-40 [18.5-30]	20.4 [518]	23.43/ 25 [595/ 635]	19.49 [495]	9.41 [239]	7.84 [200]	9.53 [242]	-	0.34 [8.5]	0.59 [15]	54.01 [24.5]
H7	IP20	30-40 [22-30]	75-100 [55-75]	50-75 [37-55]	21.65 [550]	24.8/ 27.17 [630/ 690]	20.51 [521]	12.32 [313]	10.63 [270]	13.19 [335]	-	0.34 [8.5]	0.67 [17]	79.37 [36]
H8	IP20	50-60 [37-45]	125 [90]	100-125 [75-90]	25.98 [660]	31.5 [800]	24.84 [631]	14.76 [375]	12.99 [330]	13.19 [335]	-	0.34 [8.5]	0.67 [17]	112.44 [51]
H9	IP20			3-10 [2.2-7.5]	10.59 [269]	14.72 [374]	10.12 [257]	5.12 [130]	4.33 [110]	8.07 [205]	0.43 [11]	0.59 [5.5]	0.35 [9]	14.55 [6.6]
H10	IP20			15-20 [11-15]	15.71 [399]	16.5 [419]	14.96 [380]	6.5 [165]	5.51 [140]	9.76 [248]	0.47 [12]	0.27 [6.8]	0.3 [7.5]	0.47 [12]
I2	IP54		1-5 [0.75-4.0]		13.07 [332]	-	12.54 [318.5]	4.53 [115]	2.91 [74]	8.86 [225]	0.43 [11]	0.59 [5.5]	0.35 [9]	11.68 [5.3]

Enclosure		Power (hp [kW])			Height (in [mm])			Width (in [mm])		Depth (in [mm])	Mounting hole (in [mm])			Max. Weight
Frame	IP Class	3x 200-240 V	3x 380-480 V	3x 525-600 V	A	A ¹	a	B	b	C	d	e	f	lb [kg]
I3	IP54		7.5-10 [5.5-7.5]		14.49 [368]	-	13.94 [354]	5.32 [135]	3.50 [89]	9.33 [237]	0.47 [12]	0.26 [6.5]	0.37 [9.5]	15.87 [7.2]
I4	IP54		15-25 [11-18.5]		18.74 [476]	-	18.11 [460]	7.09 [180]	5.24 [133]	11.42 [290]	0.47 [12]	0.26 [6.5]	0.37 [9.5]	30.42 [13.8]
I6	IP54		30-50 [22-37]		25.59 [650]	-	24.57 [624]	9.53 [242]	8.27 [210]	10.24 [260]	0.75 [19]	0.35 [9]	0.35 [9]	59.53 [27]
I7	IP54		60-75 [45-55]		26.77 [680]	-	25.51 [648]	12.13 [308]	10.71 [272]	12.21 [310]	0.75 [19]	0.35 [9]	0.39 [9.8]	99.21 [45]
I8	IP54		100-125 [75-90]		30.32 [770]	-	29.1 [739]	15.57 [370]	13.15 [334]	13.19 [335]	0.75 [19]	0.35 [9]	0.39 [9.8]	143.3 [65]

Table 1.5 Dimensions

¹ Including decoupling plate

The dimensions are only for the physical units, but when installing in an application it is necessary to add space for free air passage both above and below the units. The amount of space for free air passage is listed in *Table 1.6*:

Enclosure		Clearance [mm]	
Frame	IP class	Above unit	Below unit
H1	20	100	100
H2	20	100	100
H3	20	100	100
H4	20	100	100
H5	20	100	100
H6	20	200	200
H7	20	200	200
H8	20	225	225
H9	20	100	100
H10	20	200	200
I2	54	100	100
I3	54	100	100
I4	54	100	100
I6	54	200	200
I7	54	200	200
I8	54	225	225

Table 1.6 Clearance Needed for Free Air Passage

1.3.3 Electrical Installation in General

All cabling must comply with national and local regulations on cable cross-sections and ambient temperature. Copper conductors required, (167 °F [75 °C]) recommended.

Frame	IP class	Power (hp [kW])		Torque (in-lb [Nm])					
		3x200–240 V	3x380–480 V	Line	Motor	DC connection	Control terminals	Ground	Relay
H1	IP20	0.34–2 [0.25–1.5]	0.5–2 [0.37–1.5]	12.39 [1.4]	7.08 [0.8]	7.08 [0.8]	4.43 [0.5]	7.08 [0.8]	4.43 [0.5]
H2	IP20	3 [2.2]	3–5 [2.2–4]	12.39 [1.4]	7.08 [0.8]	7.08 [0.8]	4.43 [0.5]	7.08 [0.8]	4.43 [0.5]
H3	IP20	5 [3.7]	7.5–10 [5.5–7.5]	12.39 [1.4]	7.08 [0.8]	7.08 [0.8]	4.43 [0.5]	7.08 [0.8]	4.43 [0.5]
H4	IP20	7.5–10 [5.5–7.5]	15–20 [11–15]	12.39 [1.2]	12.39 [1.2]	12.39 [1.2]	4.43 [0.5]	7.08 [0.8]	4.43 [0.5]
H5	IP20	15 [11]	25–30 [18.5–22]	12.39 [1.2]	12.39 [1.2]	12.39 [1.2]	4.43 [0.5]	7.08 [0.8]	4.43 [0.5]
H6	IP20	11–25 [15–18]	40–60 [30–45]	0.18 [4.5]	0.18 [4.5]	-	4.43 [0.5]	26.55 [3]	4.43 [0.5]
H7	IP20	30–40 [22–30]	75 [55]	88.51 [10]	88.51 [10]	-	4.43 [0.5]	26.55 [3]	4.43 [0.5]
H7	IP20	-	2.95 [75]	123.91 [14]	123.91 [14]	-	4.43 [0.5]	26.55 [3]	4.43 [0.5]
H8	IP20	50–60 [37–45]	125 [90]	212.42 [24] ²	212.42 [24] ²	-	4.43 [0.5]	26.55 [3]	4.43 [0.5]

Table 1.7 Enclosure H1-H8

Power (hp [kW])			Torque (in-lb [Nm])					
Frame	IP class	3x380–480 V	Line	Motor	DC connection	Control terminals	Ground	Relay
I2	IP54	1– 5 [0.75–4.0]	12.39 [1.4]	7.08 [0.8]	7.08 [0.8]	4.43 [0.5]	7.08 [0.8]	4.43 [0.5]
I3	IP54	7.5–10 [5.5–7.5]	12.39 [1.4]	7.08 [0.8]	7.08 [0.8]	4.43 [0.5]	7.08 [0.8]	4.43 [0.5]
I4	IP54	15–25 [11–18.5]	12.39 [1.4]	7.08 [0.8]	7.08 [0.8]	4.43 [0.5]	7.08 [0.8]	4.43 [0.5]
I6	IP54	30–50 [22–37]	0.18 [4.5]	0.18 [4.5]	-	4.43 [0.5]	26.55 [3]	5.31 [0.6]
I7	IP54	60–75 [45–55]	88.51 [10]	88.51 [10]	-	4.43 [0.5]	26.55 [3]	5.31 [0.6]
I8	IP54	100–125 [75–90]	123.91/212.42 [14/24] ¹	123.91/212.42 [14/24] ¹	-	4.43 [0.5]	26.55 [3]	5.31 [0.6]

Table 1.8 Enclosure I1-I8

Power (hp [kW])			Torque (in-lb [Nm])					
Frame	IP class	3x525–600 V	Line	Motor	DC connection	Control terminals	Ground	Relay
H9	IP20	3–10 [2.2–7.5]	15.93 [1.8]	15.93 [1.8]	Not recommended	4.43 [0.5]	26.55 [3]	5.31 [0.6]
H10	IP20	15–20 [11–15]	15.93 [1.8]	15.93 [1.8]	Not recommended	4.43 [0.5]	26.55 [3]	5.31 [0.6]
H6	IP20	25–40 [18.5–30]	0.18 [4.5]	0.18 [4.5]	-	4.43 [0.5]	26.55 [3]	4.43 [0.5]
H7	IP20	50–75 [37–55]	88.51 [10]	88.51 [10]	-	4.43 [0.5]	26.55 [3]	4.43 [0.5]
H8	IP20	100–125 [75–90]	123.91/212.42 [14/24] ¹	123.91/212.42 [14/24] ¹	-	4.43 [0.5]	26.55 [3]	4.43 [0.5]

Table 1.9 Details of Tightening Torques
¹ Cable dimensions ≤ 0.1472 in² [95 mm²]

² Cable dimensions > 0.1472 in² [95 mm²]

1.3.4 Connecting to Line Power and Motor

The adjustable frequency drive is designed to operate all standard three-phased asynchronous motors. For maximum cross-section on wires, see *chapter 1.7 General Specifications*.

- Use a shielded/armored motor cable to comply with EMC emission specifications, and connect this cable to both the decoupling plate and the motor metal.
 - Keep motor cable as short as possible to reduce the noise level and leakage currents.
 - For further details on mounting of the decoupling plate, see *FC 101 Decoupling Plate Mounting Instruction*.
 - Also see *EMC-Compatible Installation in the VLT[®] HVAC Basic Design Guide*.
1. Mount the ground wires to the ground terminal.
 2. Connect the motor to terminals U, V and W.
 3. Mount line power supply to terminals L1, L2 and L3 and tighten.

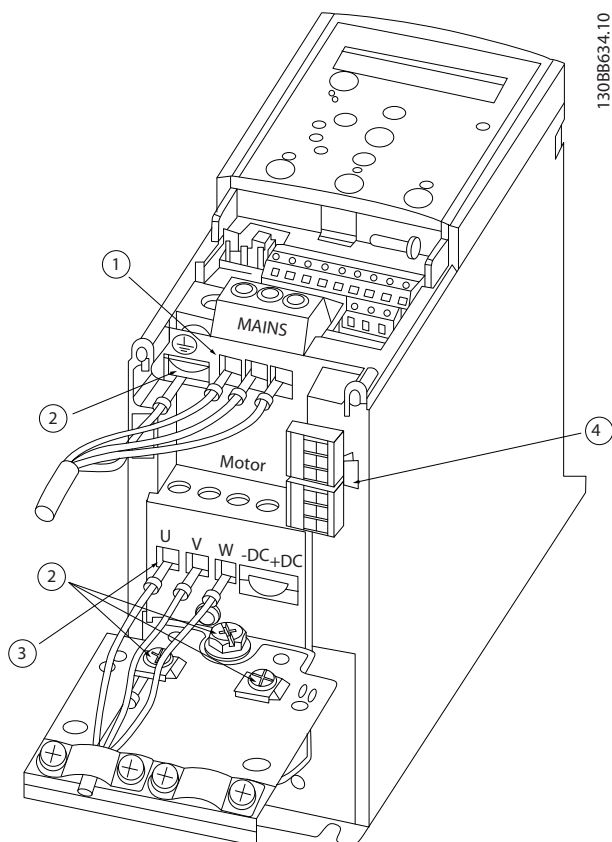

Figure 1.3 H1-H5 Frame
 IP20 200–240 V 0.34–15 hp [0.25–11 kW] and IP20 380–480 V
 0.5–30 hp [0.37–22 kW].

1	Line
2	Ground
3	Motor
4	Relays

Table 1.10 Legend to Figure 1.3

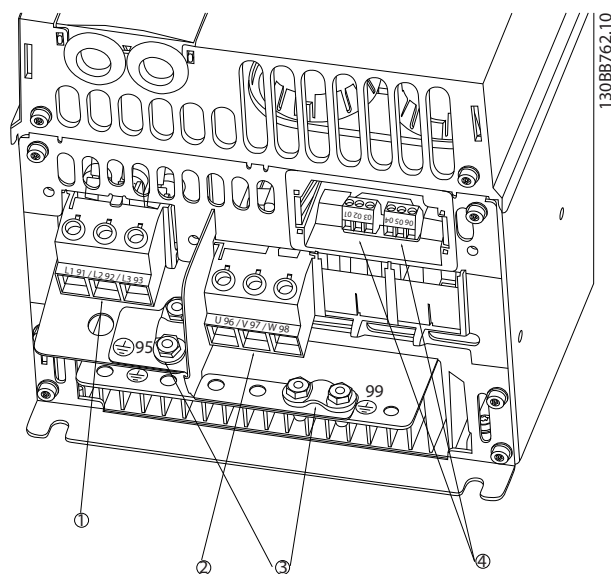

Figure 1.4 H6 Frame
 IP20 380–480 V 40–60 hp [30–45 kW]
 IP20 200–240 V 20–25 hp [15–18.5 kW]
 IP20 525–600 V 30–40 hp [22–30 kW]

1	Line
2	Motor
3	Ground
4	Relays

Table 1.11 Legend to Figure 1.4

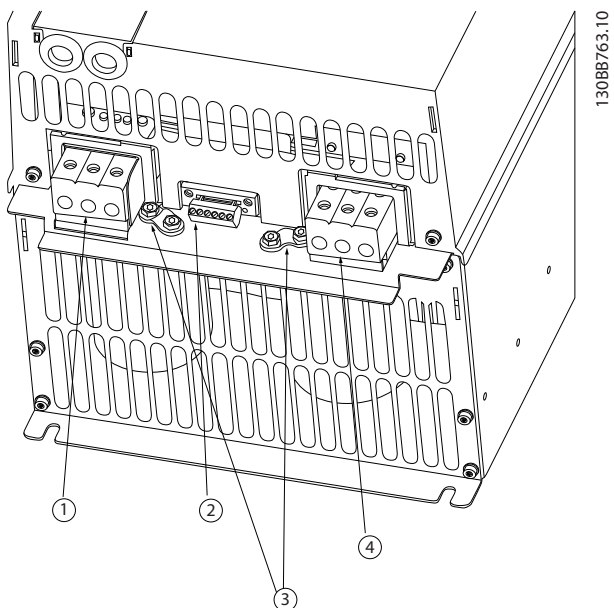

Figure 1.5 H7 Frame
 IP20 380–480 V 75–100 hp [55–75 kW]
 IP20 200–240 V 30–40 hp [22–30 kW]
 IP20 525–600 V 60–75 hp [45–55 kW]

1	Line
2	Relays
3	Ground
4	Motor

Table 1.12 Legend to Figure 1.5

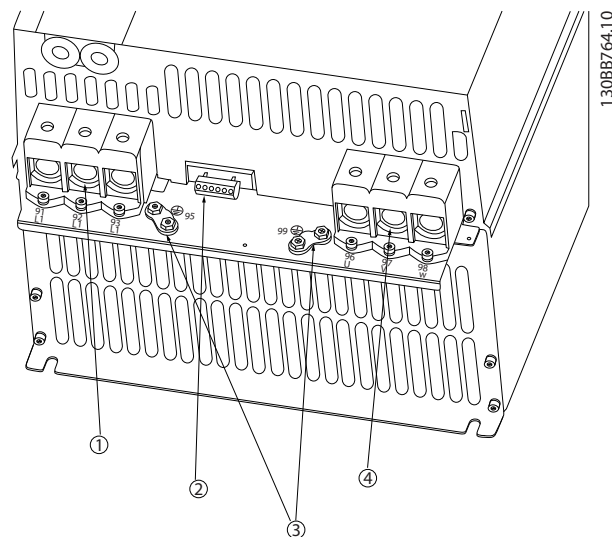

Figure 1.6 H8 Frame
 IP20 380–480 V 125 hp [90 kW]
 IP20 200–240 V 50–60 hp [37–45 kW]
 IP20 525–600 V 100–125 hp [75–90 kW]

1	Line
2	Relays
3	Ground
4	Motor

Table 1.13 Legend to Figure 1.6

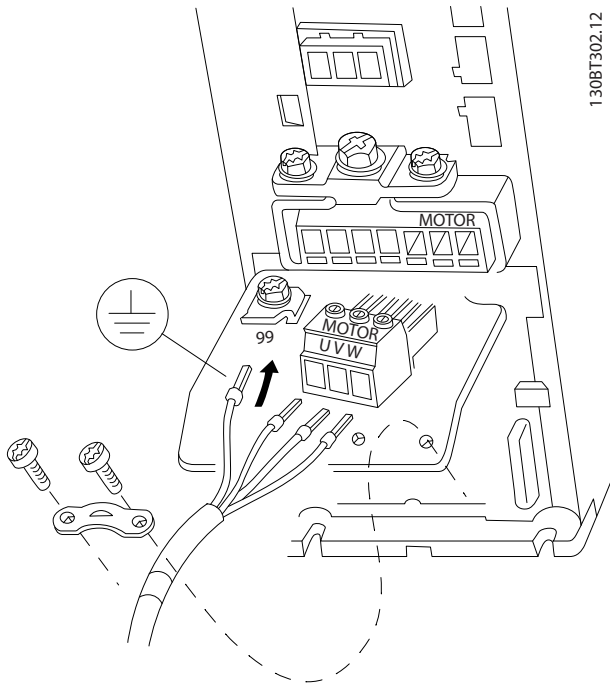

Figure 1.7 H9 Frame
IP20 600 V 3-10 hp [2.2-7.5 kW]

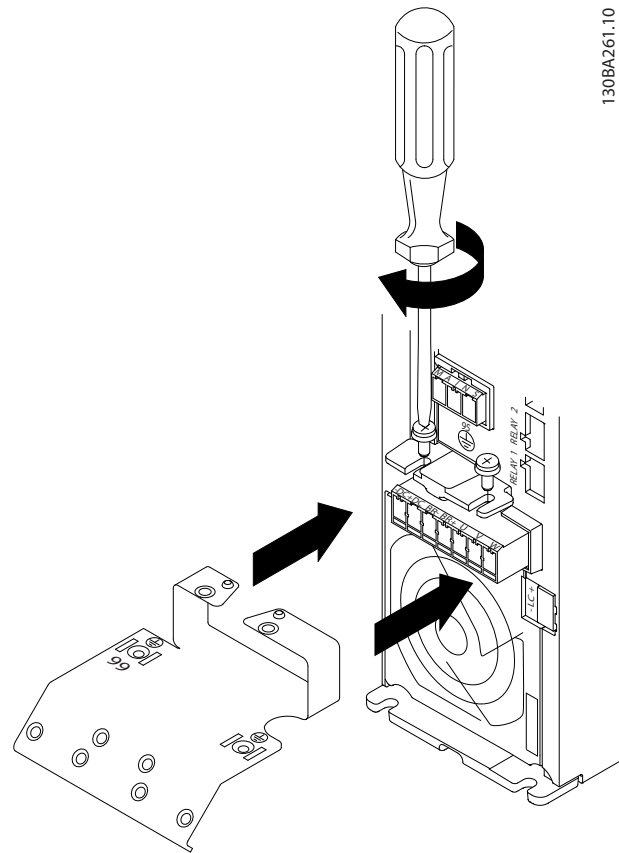

Figure 1.8 Mount the two screws in the mounting plate, slide it into place and tighten fully

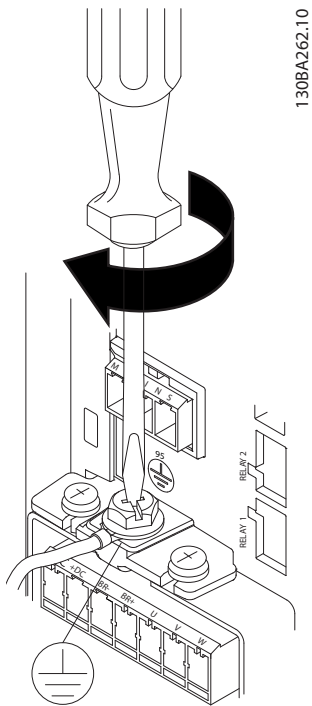

Figure 1.9 When mounting cables, first mount and tighten ground cable.

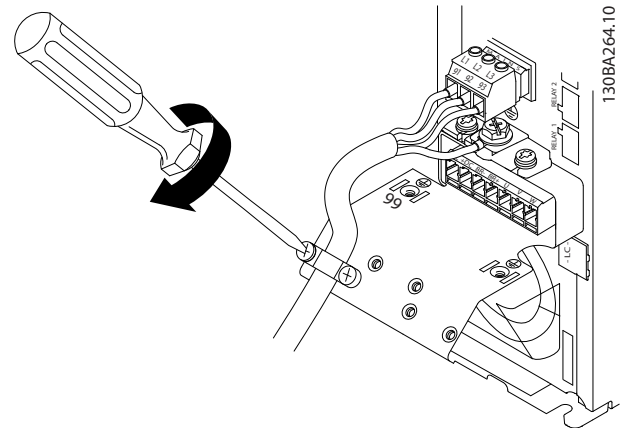

Figure 1.11 Tighten support bracket on the line power wires

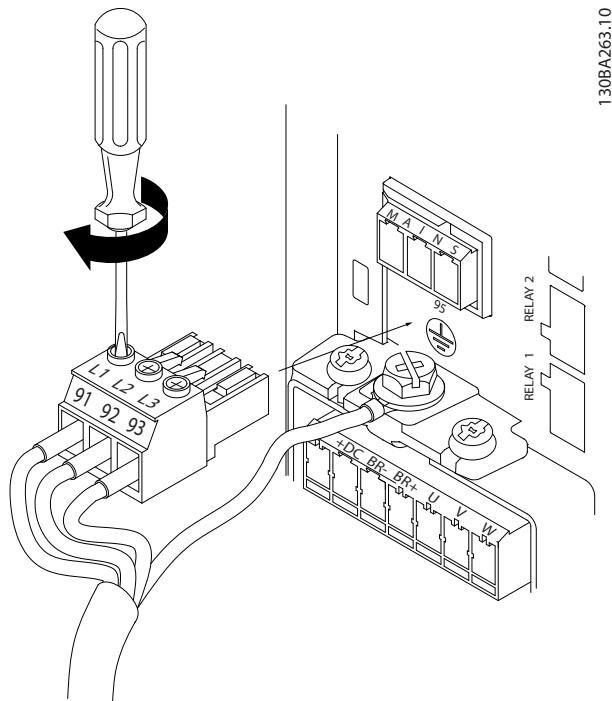

Figure 1.10 Then mount line power plug and tighten wires

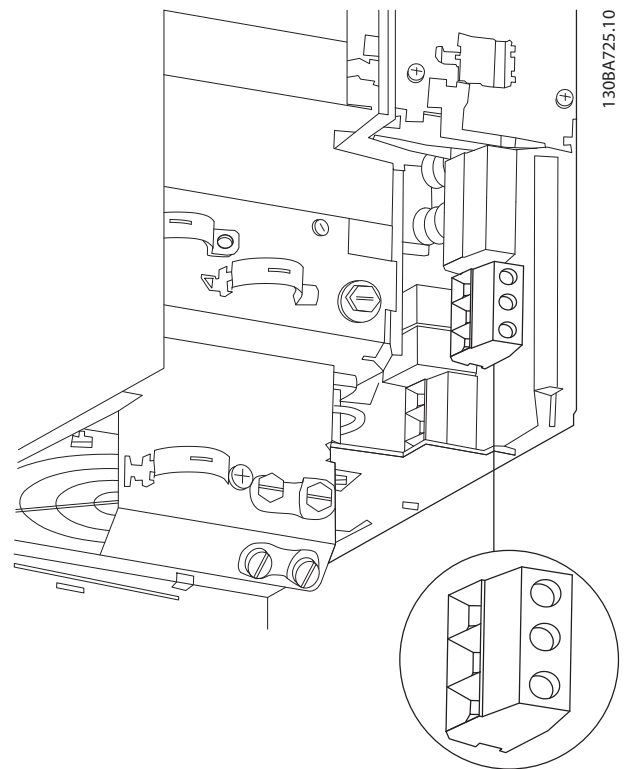

Figure 1.12 H10 Frame
IP20 600 V 15-20 hp [11-15 kW]

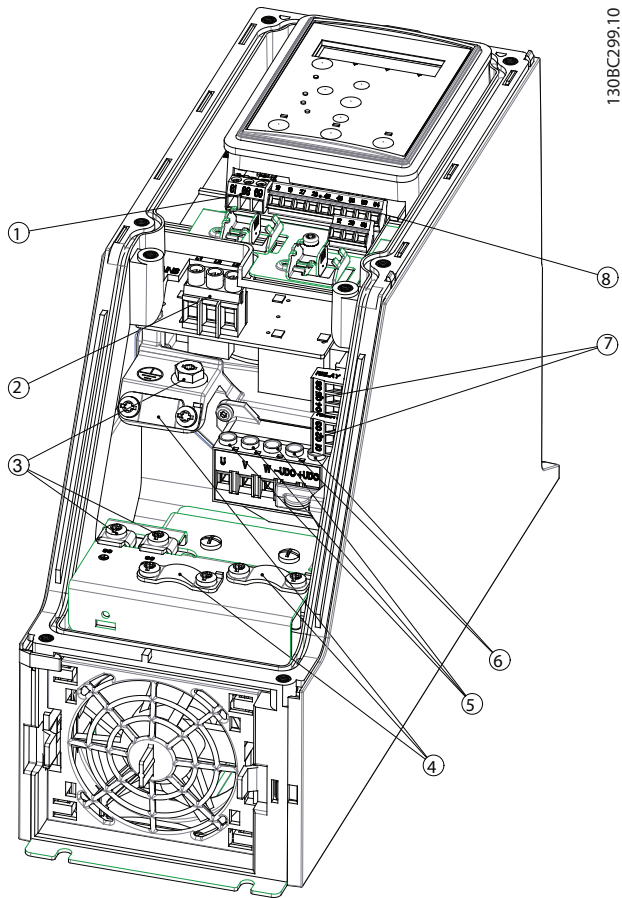

Figure 1.13 I2 Frame
IP54 380-480 V 1-5 hp [0.75-4.0 kW]

1	RS-485
2	Line in
3	Ground
4	Wire clamps
5	Motor
6	UDC
7	Relays
8	I/O

Table 1.14 Legend to Figure 1.13

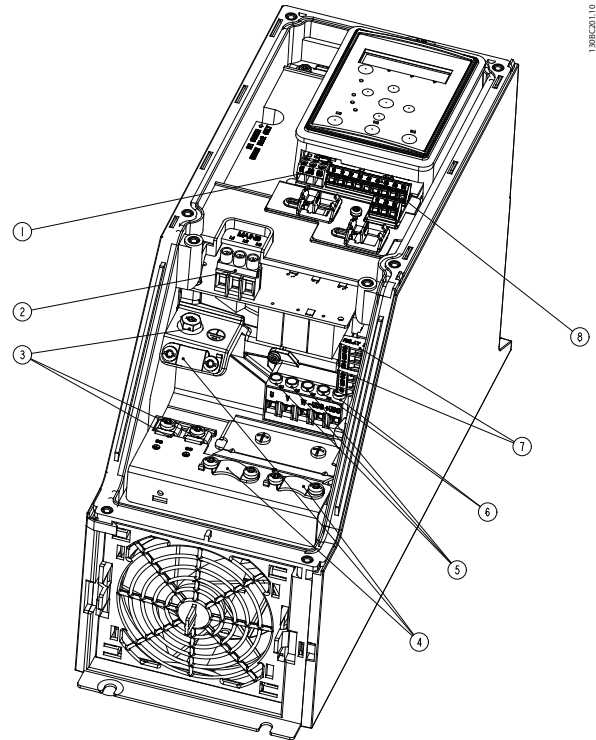
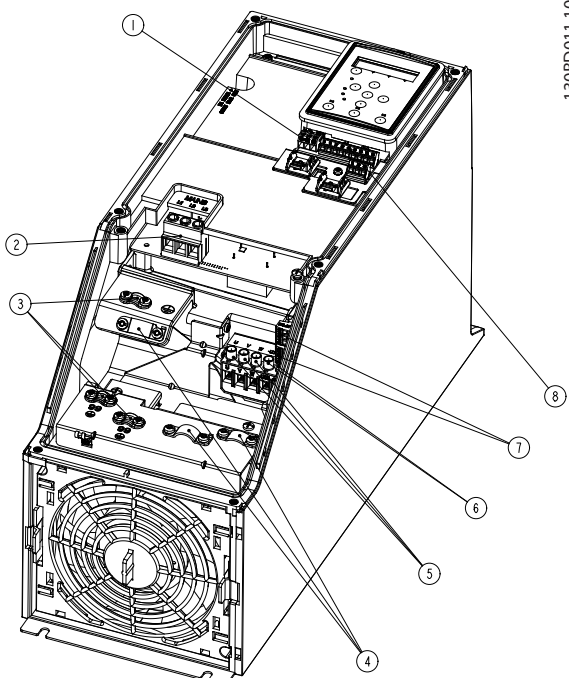

Figure 1.14 I3 Frame
IP54 380-480 V 75-100 hp [5.5-7.5 kW]

1	RS-485
2	Line in
3	Ground
4	Wire clamps
5	Motor
6	UDC
7	Relays
8	I/O

Table 1.15 Legend to Figure 1.14



130BD011.10

Figure 1.15 I4 Frame
IP54 380–480 V 1–5 hp [0.75–4.0 kW]

1	RS-485
2	Line in
3	Ground
4	Wire clamps
5	Motor
6	UDC
7	Relays
8	I/O

Table 1.16 Legend to Figure 1.15

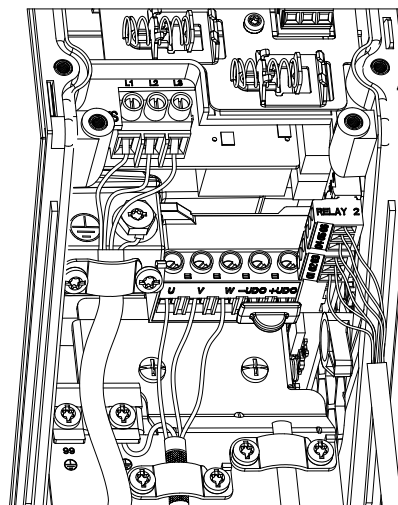

130BC203.10

Figure 1.16 IP54 I2-I3-I4 frame

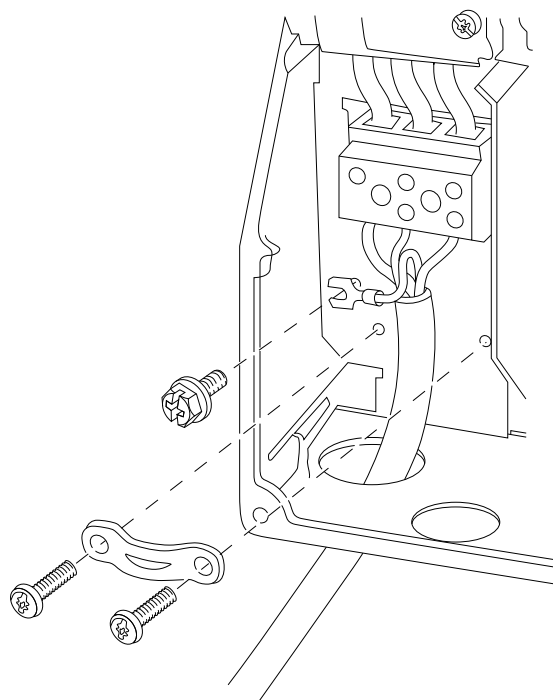

130BT326.10

Figure 1.17 I6 Frame
IP54 380-480 V 30–50 hp [22–37 kW]

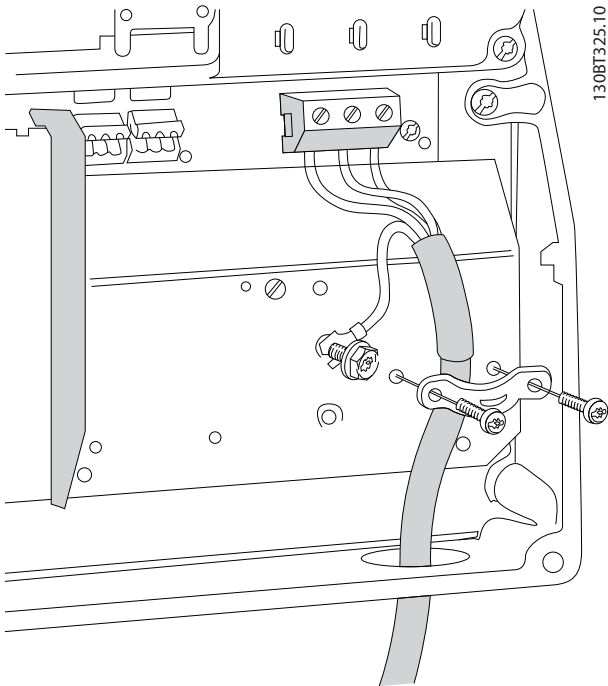

Figure 1.18 I6 Frame
IP54 380-480 V 30-50 hp [22-37 kW]

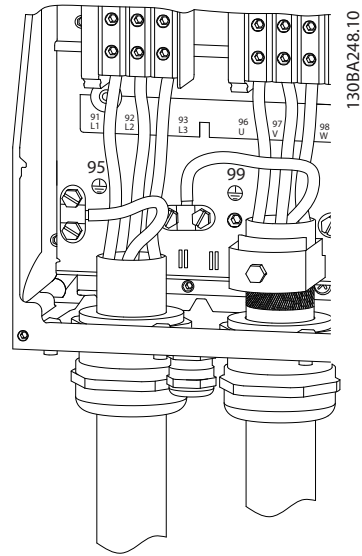

Figure 1.20 I7, I8 Frame
IP54 380-480 V 60-75 hp [45-55 kW]
IP54 380-480 V 100-125 hp [75-90 kW]

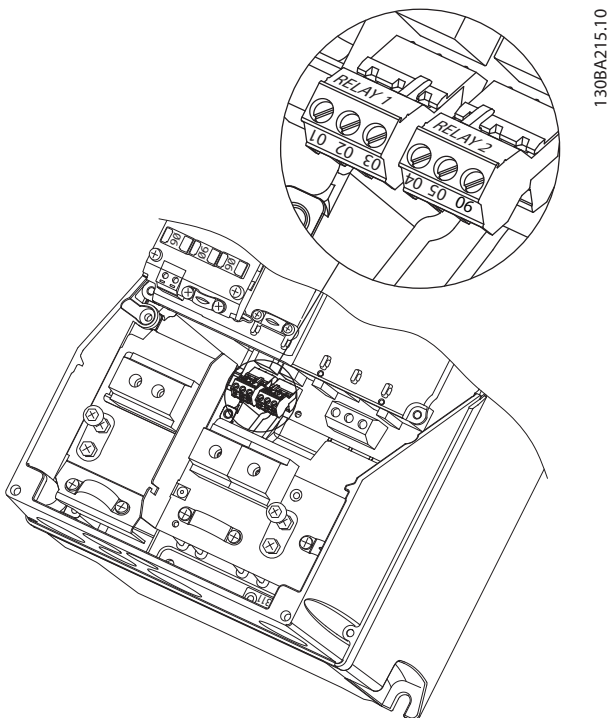

Figure 1.19 I6 Frame
IP54 380-480 V 30-50 hp [22-37 kW]

1.3.5 Fuses and Circuit Breakers

Branch circuit protection

In order to protect the installation against electrical and fire hazard, all branch circuits in an installation, switch gear, machines, etc., must be protected from short-circuits and overcurrents according to national and local regulations.

Short circuit protection

Danfoss

Overcurrent protection

Provide overload protection to avoid overheating of the cables in the installation. Overcurrent protection must always be carried out according to local and national regulations. Circuit breakers and fuses must be designed for protection in a circuit capable of supplying a maximum of 100,000 A_{rms} (symmetrical), 480 V maximum.

UL/Non-UL compliance

Use the circuit breakers or fuses listed in *Table 1.17* to ensure compliance with UL or IEC 61800-5-1.

Circuit breakers must be designed for protection in a circuit capable of supplying a maximum of 10,000 Arms (symmetrical), 480 V maximum.

In the event of malfunction, failure to follow the protection recommendation may result in damage to the adjustable frequency drive.

	Circuit Breaker		Fuse				
	UL	Non-UL	UL				Non-UL
			Bussmann	Bussmann	Bussmann	Bussmann	Max fuse
Power [kW]			Type RK5	Type RK1	Type J	Type T	Type G
3x200–240 V IP20							
0.25			FRS-R-10	KTN-R10	JKS-10	JJN-10	10
0.37			FRS-R-10	KTN-R10	JKS-10	JJN-10	10
0.75			FRS-R-10	KTN-R10	JKS-10	JJN-10	10
1.5			FRS-R-10	KTN-R10	JKS-10	JJN-10	10
2.2			FRS-R-15	KTN-R15	JKS-15	JJN-15	16
3.7			FRS-R-25	KTN-R25	JKS-25	JJN-25	25
5.5			FRS-R-50	KTN-R50	JKS-50	JJN-50	50
7.5			FRS-R-50	KTN-R50	JKS-50	JJN-50	50
11			FRS-R-80	KTN-R80	JKS-80	JJN-80	65
15	Cutler-Hammer EGE3100FFG	Moeller NZMB1- A125	FRS-R-100	KTN-R100	JKS-100	JJN-100	125
18.5			FRS-R-100	KTN-R100	JKS-100	JJN-100	125
22	Cutler-Hammer JGE3150FFG	Moeller NZMB1- A160	FRS-R-150	KTN-R150	JKS-150	JJN-150	160
30			FRS-R-150	KTN-R150	JKS-150	JJN-150	160
37	Cutler-Hammer JGE3200FFG	Moeller NZMB1- A200	FRS-R-200	KTN-R200	JKS-200	JJN-200	200
45			FRS-R-200	KTN-R200	JKS-200	JJN-200	200
3x380–480 V IP20							
0.37			FRS-R-10	KTS-R10	JKS-10	JJS-10	10
0.75			FRS-R-10	KTS-R10	JKS-10	JJS-10	10
1.5			FRS-R-10	KTS-R10	JKS-10	JJS-10	10
2.2			FRS-R-15	KTS-R15	JKS-15	JJS-15	16
3			FRS-R-15	KTS-R15	JKS-15	JJS-15	16
4			FRS-R-15	KTS-R15	JKS-15	JJS-15	16
5.5			FRS-R-25	KTS-R25	JKS-25	JJS-25	25
7.5			FRS-R-25	KTS-R25	JKS-25	JJS-25	25
11			FRS-R-50	KTS-R50	JKS-50	JJS-50	50
15			FRS-R-50	KTS-R50	JKS-50	JJS-50	50
18.5			FRS-R-80	KTS-R80	JKS-80	JJS-80	65
22			FRS-R-80	KTS-R80	JKS-80	JJS-80	65

	Circuit Breaker		Fuse				
	UL	Non-UL	UL				Non-UL
Power [kW]			Bussmann Type RK5	Bussmann Type RK1	Bussmann Type J	Bussmann Type T	Max fuse Type G
30	Cutler-Hammer EGE3125FFG	Moeller NZMB1- A125	FRS-R-125	KTS-R125	JKS-R125	JJS-R125	80
37			FRS-R-125	KTS-R125	JKS-R125	JJS-R125	100
45			FRS-R-125	KTS-R125	JKS-R125	JJS-R125	125
55	Cutler-Hammer JGE3200FFG	Moeller NZMB1- A200	FRS-R-200	KTS-R200	JKS-R200	JJS-R200	150
75			FRS-R-200	KTS-R200	JKS-R200	JJS-R200	200
90	Cutler-Hammer JGE3250FFG	Moeller NZMB2- A250	FRS-R-250	KTS-R250	JKS-R250	JJS-R250	250
3x525–600 V IP20							
2.2			FRS-R-20	KTS-R20	JKS-20	JJS-20	20
3			FRS-R-20	KTS-R20	JKS-20	JJS-20	20
3.7			FRS-R-20	KTS-R20	JKS-20	JJS-20	20
5.5			FRS-R-20	KTS-R20	JKS-20	JJS-20	20
7.5			FRS-R-20	KTS-R20	JKS-20	JJS-20	30
11			FRS-R-30	KTS-R30	JKS-30	JJS-30	35
15			FRS-R-30	KTS-R30	JKS-30	JJS-30	35
18.5	Cutler-Hammer EGE3080FFG	Cutler-Hammer EGE3080FFG	FRS-R-80	KTN-R80	JKS-80	JJS-80	80
22			FRS-R-80	KTN-R80	JKS-80	JJS-80	80
30			FRS-R-80	KTN-R80	JKS-80	JJS-80	80
37	Cutler-Hammer JGE3125FFG	Cutler-Hammer JGE3125FFG	FRS-R-125	KTN-R125	JKS-125	JJS-125	125
45			FRS-R-125	KTN-R125	JKS-125	JJS-125	125
55			FRS-R-125	KTN-R125	JKS-125	JJS-125	125
75	Cutler-Hammer JGE3200FAG	Cutler-Hammer JGE3200FAG	FRS-R-200	KTN-R200	JKS-200	JJS-200	200
90			FRS-R-200	KTN-R200	JKS-200	JJS-200	200
3x380–480 V IP54							
0.75		PKZM0-16	FRS-R-10	KTS-R-10	JKS-10	JJS-10	16
1.5		PKZM0-16	FRS-R-10	KTS-R-10	JKS-10	JJS-10	16
2.2		PKZM0-16	FRS-R-15	KTS-R-15	JKS-15	JJS-15	16
3		PKZM0-16	FRS-R-15	KTS-R-15	JKS-15	JJS-15	16
4		PKZM0-16	FRS-R-15	KTS-R-15	JKS-15	JJS-15	16
5.5		PKZM0-25	FRS-R-25	KTS-R-25	JKS-25	JJS-25	25
7.5		PKZM0-25	FRS-R-25	KTS-R-25	JKS-25	JJS-25	25
11		PKZM4-63	FRS-R-50	KTS-R-50	JKS-50	JJS-50	63
15		PKZM4-63	FRS-R-50	KTS-R-50	JKS-50	JJS-50	63
18.5		PKZM4-63	FRS-R-80	KTS-R-80	JKS-80	JJS-80	63
22	Moeller NZMB1-A125		FRS-R-80	KTS-R-80	JKS-80	JJS-80	125
30			FRS-R-125	KTS-R-125	JKS-125	JJS-125	125
37			FRS-R-125	KTS-R-125	JKS-125	JJS-125	125
45	Moeller NZMB2-A160		FRS-R-125	KTS-R-125	JKS-125	JJS-125	160
55			FRS-R-200	KTS-R-200	JKS-200	JJS-200	160
75	Moeller NZMB2-A250		FRS-R-200	KTS-R-200	JKS-200	JJS-200	200
90			FRS-R-250	KTS-R-250	JKS-200	JJS-200	200

Table 1.17 Circuit Breaker and Fuses

1.3.6 EMC-compatible Electrical Installation

General points to be observed to ensure EMC-compatible electrical installation.

- Use only shielded/armored motor cables and shielded/armored control cables.
- Connect the shield to ground at both ends.
- Avoid installation with twisted shield ends (pigtailed), since this ruins the shielding effect at high frequencies. Use the cable clamps provided instead.
- Ensure the same potential between drive and ground potential of PLC.
- Use starwashers and galvanically conductive installation plates.

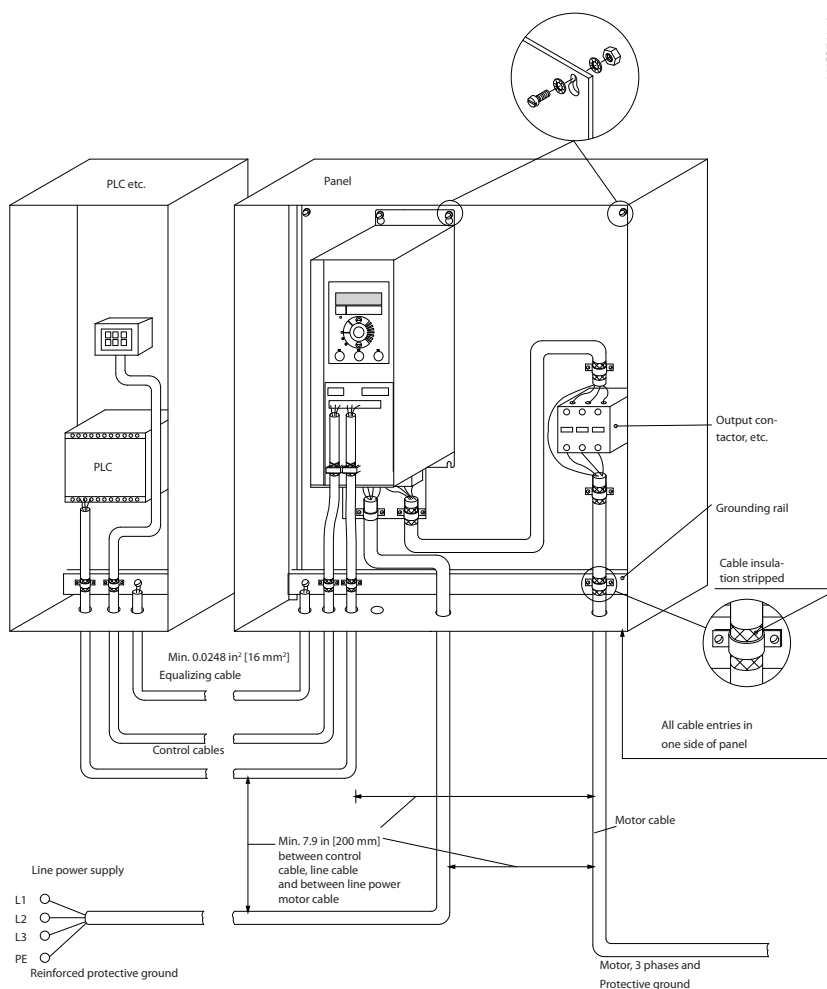

Figure 1.21 EMC-compatible Electrical Installation

For North America, use metal conduits instead of shielded cables.

1.3.7 Control Terminals

IP20 200–240 V 0.34–15 hp [0.25–11 kW] and IP20 380–480 V 0.5–30 hp [0.37–22 kW]:

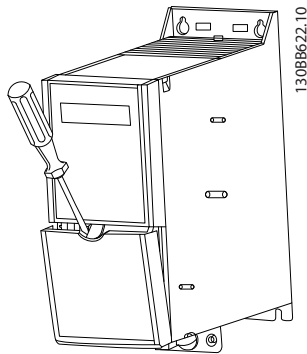

Figure 1.22 Location of Control Terminals

1. Place a screwdriver behind the terminal cover to activate snap.
2. Tilt the screwdriver outwards to open the cover.

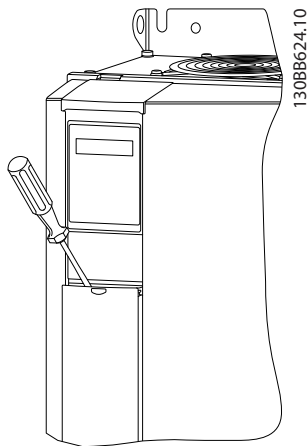

Figure 1.23 IP20 380–480 V 40–125 hp [30–90 kW]

1. Place a screwdriver behind the terminal cover to activate snap.
2. Tilt the screwdriver outwards to open the cover.

Digital input 18, 19 and 27 mode is set in 5-00 Digital Input Mode (PNP is default value) and digital input 29 mode is set in 5-03 Digital Input 29 Mode (PNP is default value).

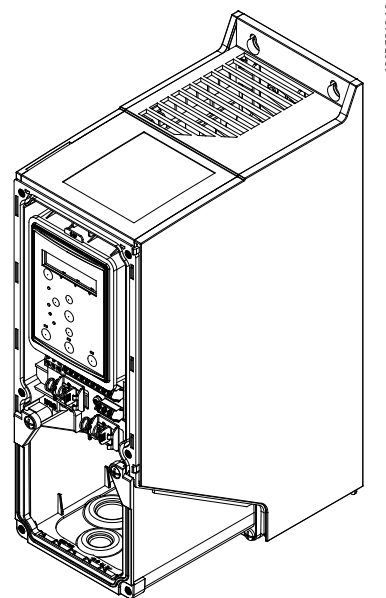

Figure 1.24 IP54 400 V 1–10 hp [0.75–7.5 kW]

1. Remove the front cover.

Control terminals

Figure 1.25 shows all control terminals of the adjustable frequency drive. Applying Start (term. 18), connection between terminal 12-27 and an analog reference (term. 53 or 54 and 55) make the adjustable frequency drive run.

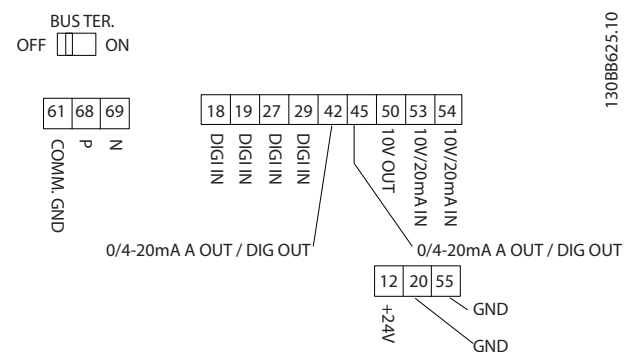

Figure 1.25 Control Terminals

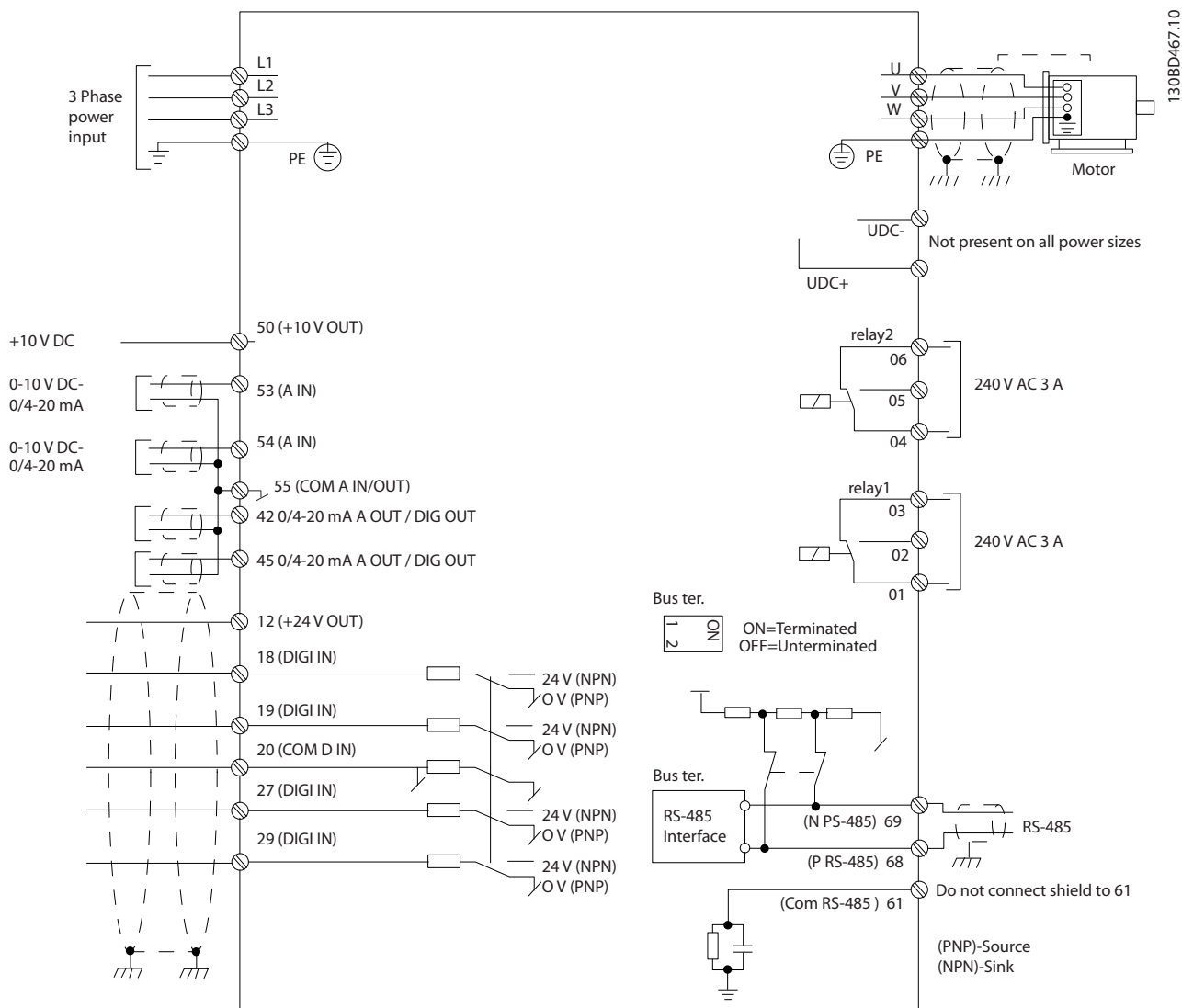

Figure 1.26 Basic Wiring Schematic Drawing

NOTICE!

There is no access to UDC- and UDC+ on the following units:

- IP20 380–480 V 40–125 hp [30–90 kW]
- IP20 200–240 V 20–60 hp [15–45 kW]
- IP20 525–600 V 3–125 hp [2.2–90 kW]
- IP54 380–480 V 30–125 hp [22–90 kW]

1.4 Programming

1.4.1 Programming with the Local Control Panel (LCP)

NOTICE!

The adjustable frequency drive can also be programmed from a PC via RS-485 COM port by installing the MCT 10 Set-up Software. This software can either be ordered using code number 130B1000 or downloaded from the Danfoss web site: www.danfoss.com/BusinessAreas/Drives-Solutions/softwaredownload

The LCP is divided into four functional sections.

- A. Alphanumeric display
- B. Menu key
- C. Navigation keys and LEDs
- D. Operation keys and LEDs

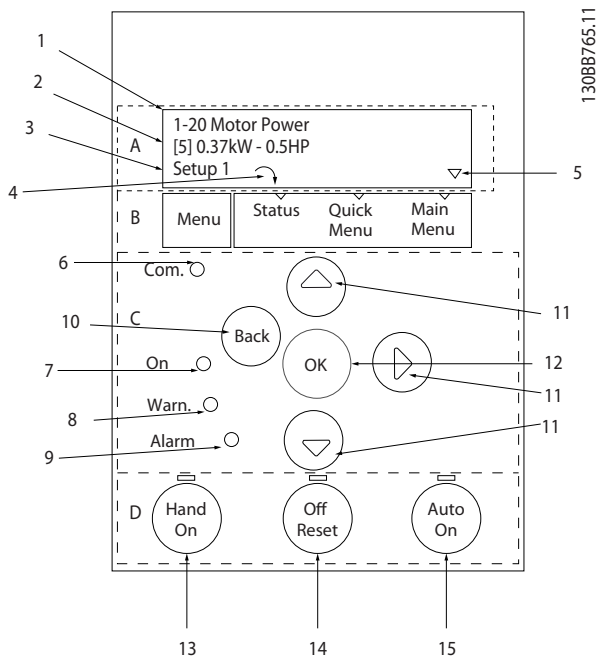

Figure 1.27 Local Control Panel (LCP)

A. Alpha Numeric Display

The LCD display is backlit with two alpha-numeric lines. All data is displayed on the LCP.

Information can be read from the display.

1	Parameter number and name.
2	Parameter value.
3	Set-up number shows the active set-up and the edit set-up. If the same set-up acts as both the active and edit set-up, only that set-up number is shown (factory setting). When the active and edit set-up differ, both numbers are shown in the display (Set-up 12). The flashing number indicates the edit set-up.
4	Motor direction is shown to the bottom left of the display – indicated by a small arrow pointing either clockwise or counter-clockwise.
5	The triangle indicates if the LCP is in status quick menu or main menu.

Table 1.18

B. Menu key

Use the menu key to select between status, quick menu or main menu.

C. Navigation keys and LEDs

6	COM LED: Flashes when bus communication is communicating.
7	Green LED/On: Control section is working.
8	Yellow LED/Warn.: Indicates a warning.
9	Flashing Red LED/Alarm: Indicates an alarm.
10	[Back]: For moving to the previous step or layer in the navigation structure
11	[▲] [▼] [▶]: For navigating between parameter groups, parameters and within parameters. Can also be used for setting local reference.
12	[OK]: For selecting a parameter and for accepting changes to parameter settings

Table 1.19

D. Operation keys and LEDs

13	<p>[Hand On]: Starts the motor and enables control of the adjustable frequency drive via the LCP.</p> <p>NOTICE!</p> <p>Terminal 27 Digital Input (5-12 Terminal 27 Digital Input) has coast inverse as default setting. This means that [Hand On] does not start the motor if there is no 24 V to terminal 27. Connect terminal 12 to terminal 27.</p>
14	<p>[Off/Reset]: Stops the motor (Off). If in alarm mode the alarm will be reset.</p>
15	<p>[Auto On]: The adjustable frequency drive is controlled either via control terminals or serial communication.</p>

Table 1.20

1.4.2 The Start-up Wizard for Open-loop Applications

The built-in wizard menu guides the installer through the set-up of the adjustable frequency drive in a clear and structured manner to set up an open-loop application. An open-loop application is here an application with a start signal, analog reference (voltage or current) and optionally also relay signals (but no feedback signal from the process applied).

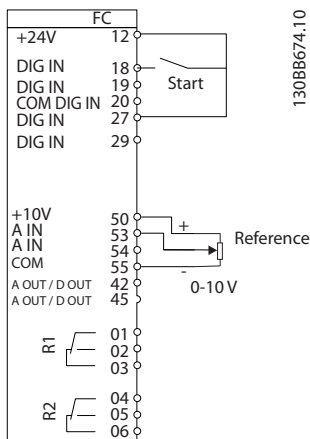

Figure 1.28 Open-loop Application

The wizard will initially be shown after power-up until any parameter has been changed. The wizard can always be accessed again through the Quick Menu. Press [OK] to start the wizard. Press [Back] to return to the status screen.

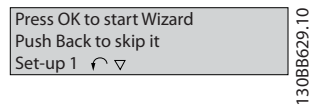

Figure 1.29 Start-up/Quit Wizard

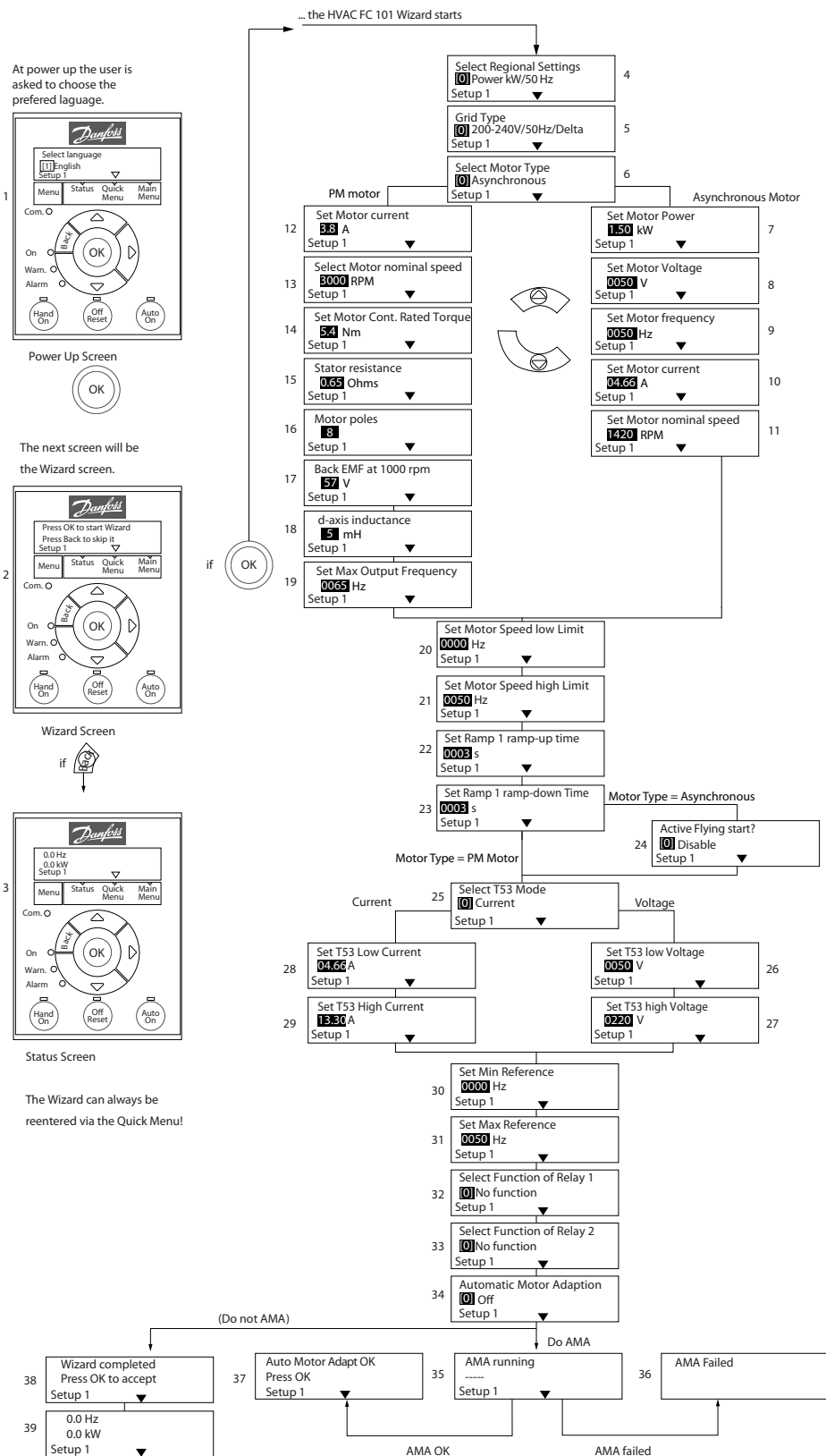

Figure 1.30 Open-loop Applications

The Start-up Wizard for Open-loop Applications

Parameter	Option	Default	Function
0-03 Regional Settings	[0] International [1] US	0	
0-06 GridType	[0] 200–240 V/50 Hz/IT grid [1] 200–240 V/50 Hz/Delta [2] 200–240 V/50 Hz [10] 380–440 V/50 Hz/IT grid [11] 380–440 V/50 Hz/Delta [12] 380–440 V/50 Hz [20] 440–480 V/50 Hz/IT grid [21] 440–480 V/50 Hz/Delta [22] 440–480 V/50 Hz [30] 525–600 V/50 Hz/IT grid [31] 525–600 V/50 Hz/Delta [32] 525–600 V/50 Hz [100] 200–240 V/60 Hz/IT grid [101] 200–240 V/60 Hz/Delta [102] 200–240 V/60 Hz [110] 380–440 V/60 Hz/IT grid [111] 380–440 V/60 Hz/Delta [112] 380–440 V/60 Hz [120] 440–480 V/60 Hz/IT grid [121] 440–480 V/60 Hz/Delta [122] 440–480 V/60 Hz [130] 525–600 V/60 Hz/IT grid [131] 525–600 V/60 Hz/Delta [132] 525–600 V/60 Hz	Size related	Select operating mode for restart upon reconnection of the drive to AC line voltage after power-down
1-10 Motor Construction	*[0] Asynchron [1] PM, non-salient SPM	[0] Asynchron	Setting the parameter value might change these parameters: 1-01 Motor Control Principle 1-03 Torque Characteristics 1-14 Damping Gain 1-15 Low Speed Filter Time Const. 1-16 High Speed Filter Time Const. 1-17 Voltage filter time const. 1-20 Motor Power [kW] 1-22 Motor Voltage 1-23 Motor Frequency 1-24 Motor Current 1-25 Motor Nominal Speed 1-26 Motor Cont. Rated Torque 1-30 Stator Resistance (Rs) 1-33 Stator Leakage Reactance (X1) 1-35 Main Reactance (Xh) 1-37 d-axis Inductance (Ld) 1-39 Motor Poles 1-40 Back EMF at 1000 RPM 1-66 Min. Current at Low Speed 1-72 Start Function 1-73 Flying Start 4-19 Max Output Frequency 4-58 Missing Motor Phase Function

Parameter	Option	Default	Function
1-20 Motor Power	0.12–110 kW/0.16–150 hp	Size related	Enter motor power from nameplate data
1-22 Motor Voltage	50.0–1000.0 V	Size related	Enter motor voltage from nameplate data
1-23 Motor Frequency	20.0–400.0 Hz	Size related	Enter motor frequency from nameplate data
1-24 Motor Current	0.01–10000.00 A	Size related	Enter motor current from nameplate data
1-25 Motor Nominal Speed	100.0–9,999.0 RPM	Size related	Enter motor nominal speed from nameplate data
1-26 Motor Cont. Rated Torque	0.1–1000.0	Size related	This parameter is available only when 1-10 Motor Construction Design is set to [1] PM, non-salient SPM. NOTICE! Changing this parameter will affect settings of other parameters
1-29 Automatic Motor Adaption (AMA)	See 1-29 Automatic Motor Adaption (AMA)	Off	Performing an AMA optimizes motor performance.
1-30 Stator Resistance (Rs)	0.000–99,990	Size related	Set the stator resistance value
1-37 d-axis Inductance (Ld)	0–1000	Size related	Enter the value of the d-axis inductance. Obtain the value from the permanent magnet motor data sheet. The de-axis inductance cannot be found by performing an AMA.
1-39 Motor Poles	2–100	4	Enter the number of motor poles
1-40 Back EMF at 1000 RPM	10–9000	Size related	Line-Line RMS back EMF voltage at 1000 RPM
1-73 Flying Start			When PM is selected, Flying Start is enabled and cannot disable
1-73 Flying Start	[0] Disabled [1] Enabled	0	Select [1] Enable to enable the drive to catch a motor spinning due to line drop-out. Select [0] Disable if this function is not required. When is enabled 1-71 Start Delay and 1-72 Start Function have no function. is active in VVC ^{plus} mode only
3-02 Minimum Reference	-4999–4999	0	The minimum reference is the lowest value obtainable by summing all references.
3-03 Maximum Reference	-4999–4999	50	The maximum reference is the lowest obtainable by summing all references.
3-41 Ramp 1 Ramp Up Time	0.05–3600.0 s	Size related	Ramp-up time from 0 to rated 1-23 Motor Frequency if Asynchron motor is selected; ramp-up time from 0 to 1-25 Motor Nominal Speed if PM motor is selected
3-42 Ramp 1 Ramp Down Time	0.05–3600.0 s	Size related	Ramp-down time from rated 1-23 Motor Frequency to 0 if Asynchron motor is selected; ramp-down time from 1-25 Motor Nominal Speed to 0 if PM motor is selected.
4-12 Motor Speed Low Limit [Hz]	0.0–400 Hz	0 Hz	Enter the minimum limit for low speed
4-14 Motor Speed High Limit [Hz]	0.0–400 Hz	65 Hz	Enter the maximum limit for high speed
4-19 Max Output Frequency	0-400	Size related	Enter the maximum output frequency value
5-40 Function Relay [0] Function relay	See 5-40 Function Relay	Alarm	Select the function to control output relay 1.
5-40 Function Relay [1] Function relay	See 5-40 Function Relay	Drive running	Select the function to control output relay 2.
6-10 Terminal 53 Low Voltage	0–10 V	0.07 V	Enter the voltage that corresponds to the low reference value.

Parameter	Option	Default	Function
6-11 Terminal 53 High Voltage	0–10 V	10 V	Enter the voltage that corresponds to the high reference value.
6-12 Terminal 53 Low Current	0–20 mA	4	Enter the current that corresponds to the low reference value.
6-13 Terminal 53 High Current	0–20 mA	20	Enter the current that corresponds to the high reference value.
6-19 Terminal 53 mode	[0] Current [1] Voltage	1	Select if terminal 53 is used for current or voltage input.

Table 1.21 Open-loop Applications Set-up

Closed-loop Set-up Wizard

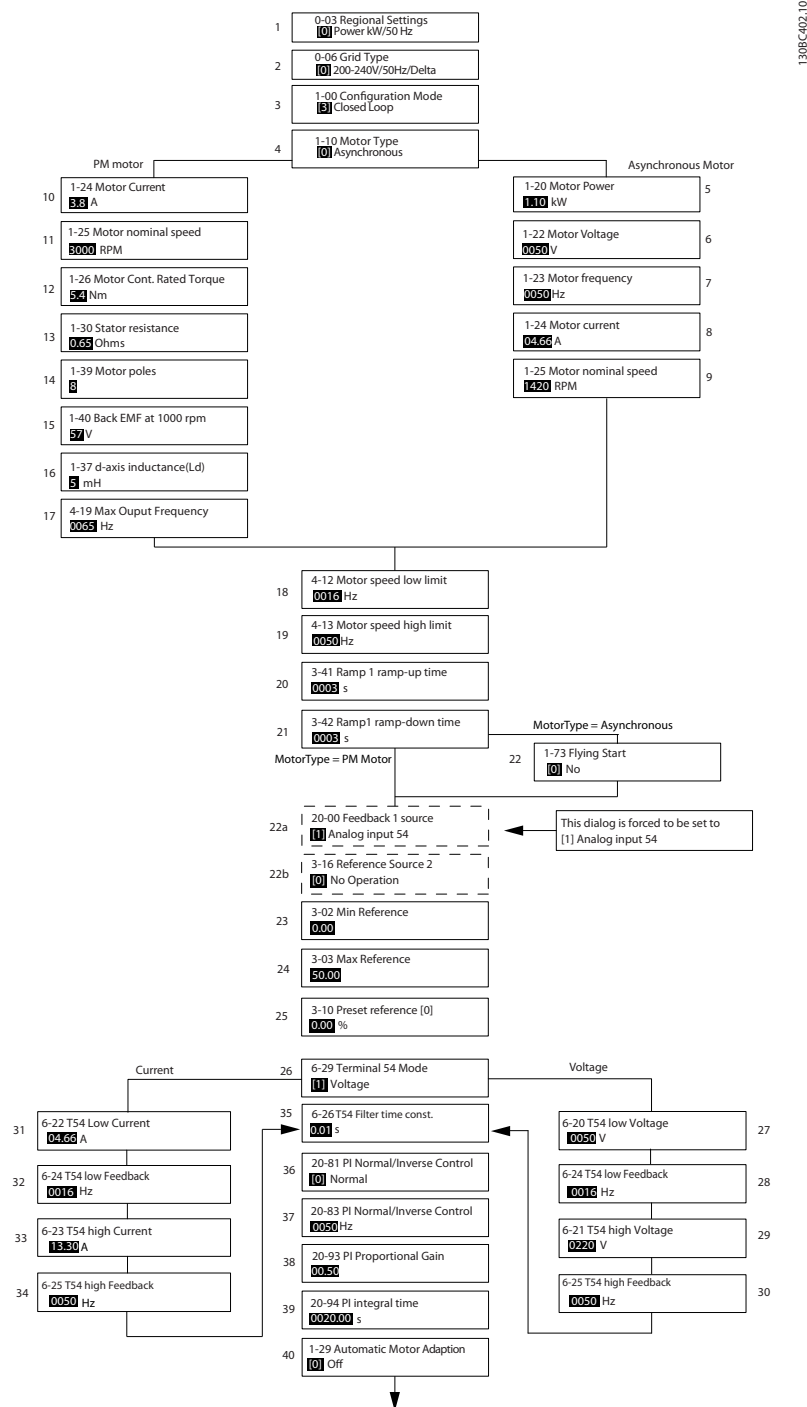

130BC-002.10

Figure 1.31 Closed-loop

Parameter	Range	Default	Function
0-03 Regional Settings	[0] International [1] US	0	
0-06 GridType	[0] -[[132] see start-up wizard for open-loop application	Size selected	Select operating mode for restart upon reconnection of the adjustable frequency drive to AC line voltage after power-down.
1-00 Configuration Mode	[0] Open-loop [3] Closed-loop	0	Change this parameter to Closed-loop
1-10 Motor Construction	*[0] Motor construction [1] PM, non-salient SPM	[0] Asynchron	Setting the parameter value might change these parameters: 1-01 Motor Control Principle 1-03 Torque Characteristics 1-14 Damping Gain 1-15 Low Speed Filter Time Const. 1-16 High Speed Filter Time Const. 1-17 Voltage filter time const. 1-20 Motor Power [kW] 1-22 Motor Voltage 1-23 Motor Frequency 1-25 Motor Nominal Speed 1-26 Motor Cont. Rated Torque 1-30 Stator Resistance (Rs) 1-33 Stator Leakage Reactance (X1) 1-35 Main Reactance (Xh) 1-37 d-axis Inductance (Ld) 1-39 Motor Poles 1-40 Back EMF at 1000 RPM 1-66 Min. Current at Low Speed 1-72 Start Function 1-73 Flying Start 4-19 Max Output Frequency 4-58 Missing Motor Phase Function
1-20 Motor Power	0.125–150 hp [0.09–110 kW]	Size related	Enter motor power from nameplate data
1-22 Motor Voltage	50.0–1000.0 V	Size related	Enter motor voltage from nameplate data
1-23 Motor Frequency	20.0–400.0 Hz	Size related	Enter motor frequency from nameplate data
1-24 Motor Current	0.0–10000.00 A	Size related	Enter motor current from nameplate data
1-25 Motor Nominal Speed	100.0–9,999.0 RPM	Size related	Enter motor nominal speed from nameplate data
1-26 Motor Cont. Rated Torque	0.1–1000.0	Size related	This parameter is available only when 1-10 Motor Construction Design is set to [1] PM, non-salient SPM. NOTICE! Changing this parameter affects the settings of other parameters
1-29 Automatic Motor Adaption (AMA)		Off	Performing an AMA optimizes motor performance.
1-30 Stator Resistance (Rs)	0.000–99.990	Size related	Set the stator resistance value
1-37 d-axis Inductance (Ld)	0–1000	Size related	Enter the value of the d-axis inductance. Obtain the value from the permanent magnet motor data sheet. The de-axis inductance cannot be found by performing an AMA.

Parameter	Range	Default	Function
1-39 Motor Poles	2–100	4	Enter the number of motor poles
1-40 Back EMF at 1000 RPM	10–9000	Size related	Line-Line RMS back EMF voltage at 1000 RPM
1-73 Flying Start	[0] Disabled [1] Enabled	0	Select [1] <i>Enable</i> to enable the adjustable frequency drive to catch a spinning motor, e.g., in fan applications. When PM is selected, Flying Start is enabled.
3-02 Minimum Reference	-4999–4999	0	The minimum reference is the lowest value obtainable by summing all references.
3-03 Maximum Reference	-4999–4999	50	The maximum reference is the highest value obtainable by summing all references.
3-10 Preset Reference	-100–100%	0	Enter the setpoint.
3-41 Ramp 1 Ramp Up Time	0.05–3600.0 s	Size related	Ramp-up time from 0 to rated 1-23 Motor Frequency if Asynchron motor is selected; ramp-up time from 0 to 1-25 Motor Nominal Speed if PM motor is selected.
3-42 Ramp 1 Ramp Down Time	0.05–3600.0 s	Size related	Ramp-down time from rated 1-23 Motor Frequency to 0 if Asynchron motor is selected; ramp-down time from 1-25 Motor Nominal Speed to 0 if PM motor is selected.
4-12 Motor Speed Low Limit [Hz]	0.0–400 Hz	0.0 Hz	Enter the minimum limit for low speed
4-14 Motor Speed High Limit [Hz]	0–400 Hz	65 Hz	Enter the minimum limit for high speed
4-19 Max Output Frequency	0-400	Size related	Enter the maximum output frequency value
6-29 Terminal 54 mode	[0] Current [1] Voltage	1	Select if terminal 54 is used for current or voltage input
6-20 Terminal 54 Low Voltage	0–10 V	0.07 V	Enter the voltage that corresponds to the low reference value.
6-21 Terminal 54 High Voltage	0–10 V	10 V	Enter the voltage that corresponds to the low high reference value.
6-22 Terminal 54 Low Current	0–20 mA	4	Enter the current that corresponds to the high reference value.
6-23 Terminal 54 High Current	0–20 mA	20	Enter the current that corresponds to the high reference value.
6-24 Terminal 54 Low Ref./Feedb. Value	-4999–4999	0	Enter the feedback value that corresponds to the voltage or current set in 6-20 <i>Terminal 54 Low Voltage</i> /6-22 <i>Terminal 54 Low Current</i>
6-25 Terminal 54 High Ref./Feedb. Value	-4999–4999	50	Enter the feedback value that corresponds to the voltage or current set in 6-21 <i>Terminal 54 High Voltage</i> /6-23 <i>Terminal 54 High Current</i>
6-26 Terminal 54 Filter Time Constant	0–10 s	0.01	Enter the filter time constant.
20-81 PI Normal/ Inverse Control	[0] Normal [1] Inverse	0	Select [0] <i>Normal</i> to set the process control to increase the output speed when the process error is positive. Select [1] <i>Inverse</i> to reduce the output speed.
20-83 PI Start Speed [Hz]	0–200 Hz	0	Enter the motor speed to be attained as a start signal for commencement of PI control.
20-93 PI Proportional Gain	0–10	0.01	Enter the process controller proportional gain. Quick control is obtained at high amplification. However, if amplification is too great, the process may become unstable.

Parameter	Range	Default	Function
20-94 PI Integral Time	0.1–999.0 s	999.0 s	Enter the process controller integral time. Obtain quick control through a short integral time, though if the integral time is too short, the process becomes unstable. An excessively long integral time disables the integral action.

Table 1.22 Closed-loop Set-up

Motor set-up

The Quick Menu Motor Set-up guides you through the needed motor parameters.

Parameter	Range	Default	Function
0-03 Regional Settings	[0] International [1] US	0	
0-06 GridType	[0] -[132] see start-up wizard for open-loop application	Size selected	Select operating mode for restart upon reconnection of the drive to AC line voltage after power-down
1-10 Motor Construction	*[0] Motor construction [1] PM, non-salient SPM	[0] Asynchron	
1-20 Motor Power	0.12–110 kW/0.16–150 hp	Size related	Enter motor power from nameplate data
1-22 Motor Voltage	50.0–1000.0 V	Size related	Enter motor voltage from nameplate data
1-23 Motor Frequency	20.0–400.0 Hz	Size related	Enter motor frequency from nameplate data
1-24 Motor Current	0.01–10000.00 A	Size related	Enter motor current from nameplate data
1-25 Motor Nominal Speed	100.0–9,999.0 RPM	Size related	Enter motor nominal speed from nameplate data
1-26 Motor Cont. Rated Torque	0.1–1000.0	Size related	This parameter is available only when 1-10 Motor Construction Design is set to [1] PM, non-salient SPM. NOTICE! Changing this parameter affects the settings of other parameters
1-30 Stator Resistance (Rs)	0.000–99.990	Size related	Set the stator resistance value
1-37 d-axis Inductance (Ld)	0–1000	Size related	Enter the value of the d-axis inductance. Obtain the value from the permanent magnet motor data sheet. The de-axis inductance cannot be found by performing an AMA.
1-39 Motor Poles	2–100	4	Enter the number of motor poles
1-40 Back EMF at 1000 RPM	10–9000	Size related	Line-Line RMS back EMF voltage at 1000 RPM
1-73 Flying Start	[0] Disabled [1] Enabled	0	Select Enable to enable the adjustable frequency drive to catch a spinning motor.
3-41 Ramp 1 Ramp Up Time	0.05–3600.0 s	Size related	Ramp-up time from 0 to rated <i>1-23 Motor Frequency</i>

Parameter	Range	Default	Function
3-42 Ramp 1 Ramp Down Time	0.05–3600.0 s	Size related	Ramp-down time from rated 1-23 Motor Frequency to 0
4-12 Motor Speed Low Limit [Hz]	0.0–400 Hz	0.0 Hz	Enter the minimum limit for low speed
4-14 Motor Speed High Limit [Hz]	0.0–400 Hz	65	Enter the maximum limit for high speed
4-19 Max Output Frequency	0-400	Size related	Enter the maximum output frequency value

Table 1.23 Motor Set-up

Changes Made

Changes Made lists all parameters changed from default settings.

- The list shows only parameters which have been changed in the current edit set-up.
- Parameters which have been reset to default values are not listed.
- The message 'Empty' indicates that no parameters have been changed.

To change parameter settings

1. Press [Menu] to enter the Quick Menu until indicator in display is placed above Quick Menu.
2. Press [▲] [▼] to select wizard, closed-loop set-up, motor set-up or changes made, then press [OK].
3. Press [▲] [▼] to browse through the parameters in the Quick Menu.
4. Press [OK] to select a parameter.
5. Press [▲] [▼] to change the value of a parameter setting.
6. Press [OK] to accept the change.
7. Press either [Back] twice to enter "Status", or press [Menu] once to enter "Main Menu".

The Main Menu accesses all parameters.

1. Press [Menu] until indicator in display is placed above "Main Menu".
2. Press [▲] [▼] to browse through the parameter groups.
3. Press [Ok] to select a parameter group.
4. Press [▲] [▼] to browse through the parameters in the specific group.
5. Press [Ok] to select the parameter.
6. Press [▲] [▼] to set/change the parameter value.

1.4.3 Main menu structure	1-42 Motor Cable Length	Motor Cable Length Feet	4-1* Motor Limits	6-21 Terminal 54 High Voltage	8-88 Reset FC Port Diagnostics
	1-43 Motor Cable Length Feet	Motor Cable Length Feet	4-10 Motor Speed Direction	6-22 Terminal 54 Low Current	8-9* Bus Feedback
	1-5* Load Indep. Setting	Motor Speed Low Limit [Hz]	4-12 Motor Speed Low Limit [Hz]	6-23 Terminal 54 High Current	8-94 Bus Feedback 1
	1-50 Motor Magnetization at Zero Speed	Motor Magnetization at Zero Speed	4-14 Motor Speed High Limit [Hz]	6-24 Terminal 54 Low Ref./Feedb. Value	13-3** Smart Logic
	1-52 Min Speed Normal Magnetizing [Hz]	Min Speed Normal Magnetizing [Hz]	4-18 Current Limit	6-25 Terminal 54 High Ref./Feedb. Value	13-0* SLC Settings
	1-55 U/f Characteristic - U	U/f Characteristic - U	4-19 Max Output Frequency	6-26 Terminal 54 Filter Time Constant	13-00 SL Controller Mode
	1-56 U/f Characteristic - F	U/f Characteristic - F	4-4* Adj. Warnings 2	6-29 Terminal 54 mode	13-01 Start Event
	1-6* Load Depen. Setting	Low Speed Load Compensation	4-40 Warning Freq. Low	6-7* Analog/Digital Output 45	13-02 Stop Event
	1-60 Operating State at Power-up	High Speed Load Compensation	4-41 Warning Freq. High	6-70 Terminal 45 Mode	13-03 Reset SLC
	0-04 GridType	Slip Compensation	4-5* Adj. Warnings	6-71 Terminal 45 Analog Output	13-1* Comparators
	0-06 Auto DC Braking	Slip Compensation	4-50 Warning Current Low	6-72 Terminal 45 Digital Output	13-10 Comparator Operand
	0-1* Set-up Operations	Slip Compensation Time Constant	4-51 Warning Current High	6-73 Terminal 45 Output Min Scale	13-11 Comparator Operator
	0-10 Active Set-up	Resonance Dampening	4-54 Warning Reference Low	6-74 Terminal 45 Output Max Scale	13-12 Comparator Value
	0-11 Programming Set-up	Resonance Dampening Time	4-55 Warning Reference High	6-76 Terminal 45 Output Bus Control	13-2* Timers
	0-12 Link Set-ups	Constant	4-56 Warning Feedback Low	6-9* Analog/Digital Output 42	13-20 SL Controller Timer
	0-3* LCP Custom Readout	Min. Current at Low Speed	4-57 Warning Feedback High	6-90 Terminal 42 Mode	13-4* Logic Rules
	0-30 Custom Readout Unit	Start Adjustments	4-58 Missing Motor Phase Function	6-91 Terminal 42 Analog Output	13-40 Logic Rule Boolean 1
	0-31 Custom Readout Min Value	Start Delay	4-6* Speed Bypass	6-92 Terminal 42 Digital Output	13-41 Logic Rule Operator 1
	0-32 Custom Readout Max Value	Start Function	4-61 Bypass Speed From [Hz]	6-93 Terminal 42 Output Min Scale	13-42 Logic Rule Boolean 2
	0-37 Display Text 1	Flying Start	4-63 Bypass Speed To [Hz]	6-94 Terminal 42 Output Max Scale	13-43 Logic Rule Operator 2
	0-38 Display Text 2	Stop Adjustments	4-64 Semi-Auto Bypass Set-up	6-96 Terminal 42 Output Bus Control	13-44 Logic Rule Boolean 3
	0-39 Display Text 3	Function at Stop	5-5** Digital In/Out	6-98 Drive Type	13-5* States
	0-4* LCP Keypad	Min Speed for Function at Stop [Hz]	5-0* Digital I/O mode	8-8** Comm. and Options	13-51 SL Controller Event
	0-40 [Hand on] Key on LCP	Motor Temperature	5-00 Digital Input Mode	8-0* General Settings	13-52 SL Controller Action
	0-42 [Auto on] Key on LCP	Motor Thermal Protection	5-03 Digital Input 29 Mode	8-01 Control Site	14-0** Special Functions
	0-44 [Off/Reset] Key on LCP	Thermistor Source	5-1* Digital Inputs	8-02 Control Source	14-0* Inverter Switching
	0-5* Copy/Save	Brakes	5-10 Terminal 18 Digital Input	8-03 Control Timeout Time	14-01 Switching Frequency
	0-50 LCP Copy	DC Brake	5-11 Terminal 19 Digital Input	8-04 Control Timeout Function	14-03 Overmodulation
	0-51 Set-up Copy	DC Hold/Motor Preheat Current	5-12 Terminal 27 Digital Input	8-3* FC Port Settings	14-08 Damping Gain Factor
	0-6* Password	DC Brake Current	5-13 Terminal 29 Digital Input	8-30 Protocol	14-1* Mains On/Off
	1-0* Load and Motor	DC Braking Time	5-3* Digital Outputs	8-31 Address	14-10 Mains Failure
	1-00 General Settings	DC Braking Time	5-34 On Delay, Digital Output	8-32 Baud Rate	14-12 Function at Mains Imbalance
	1-00 Configuration Mode	Parking Current	5-35 Off Delay, Digital Output	8-33 Parity / Stop Bits	14-2* Reset Functions
	1-01 Motor Control Principle	Brake Energy Funct.	5-4* Relays	8-35 Minimum Response Delay	14-20 Reset Mode
	1-03 Torque Characteristics	Brake Function	5-40 Function Relay	8-36 Maximum Response Delay	14-21 Automatic Restart Time
	1-06 Clockwise Direction	AC Brake, Max current	5-41 On Delay, Relay	8-37 Maximum Inter-char delay	14-22 Operation Mode
	1-1* Motor Selection	Over-voltage Control	5-42 Off Delay, Relay	8-4* FC MC protocol set	14-23 Typecode Setting
	1-10 Motor Construction	Reference / Ramps	5-5* Pulse Input	8-43 PCD Read Configuration	14-27 Action At Inverter Fault
	1-14 Damping Gain	Reference Limits	5-50 Term. 29 Low Frequency	8-5* Digital/Bus	14-28 Production Settings
	1-15 Low Speed Filter Time Const	Minimum Reference	5-51 Term. 29 High Frequency	8-50 Coasting Select	14-29 Service Code
	1-16 High Speed Filter Time Const	Maximum Reference	5-52 Term. 29 Low Ref./Feedb. Value	8-51 Quick Stop Select	14-4* Energy Optimizing
	1-17 Voltage filter time const	References	5-53 Term. 29 High Ref./Feedb. Value	8-52 DC Brake Select	14-40 VT Level
	1-2* Motor Data	Preset Reference	5-9* Bus Controlled	8-53 Start Select	14-41 AEO Minimum Magnetization
	1-20 Motor Power	Jog Speed [Hz]	5-90 Digital & Relay Bus Control	8-54 Reversing Select	14-5* Environment
	1-22 Motor Voltage	Preset Relative Reference	6-6** Analog In/Out	8-55 Set-up Select	14-50 RFI Filter
	1-23 Motor Frequency	Reference 1 Source	6-0* Analog I/O Mode	8-56 Preset Reference Select	14-51 DC Link Voltage Compensation
	1-24 Motor Current	Reference 2 Source	6-00 Live Zero Timeout Time	8-7* BACnet	14-52 Fan Control
	1-25 Motor Nominal Speed	Reference 3 Source	6-01 Live Zero Timeout Function	8-70 BACnet Device Instance	14-53 Fan Monitor
	1-26 Motor Cont. Rated Torque	Ramp 1	6-1* Analog Input 53	8-72 MS/TP Max Masters	14-55 Output Filter
	1-29 Automatic Motor Adaption (AMA)	Ramp 1 Ramp-up Time	6-10 Terminal 53 Low Voltage	8-73 MS/TP Max Info Frames	14-6* Auto Derate
	1-3* Adv. Motor Data	Ramp 1 Ramp-down Time	6-11 Terminal 53 High Voltage	8-74 "I am" Service	14-63 Min Switch Frequency
	1-30 Stator Resistance (Rs)	Ramp 2	6-12 Terminal 53 Low Current	8-75 Initialisation Password	15-5** Drive Information
	1-33 Stator Leakage Reactance (Xl)	Ramp 2 Ramp-up Time	6-13 Terminal 53 High Current	8-8* FC Port Diagnostics	15-0* Operating Data
	1-35 Main Reactance (Xh)	Ramp 2 Ramp-down Time	6-15 Terminal 53 Low Ref./Feedb. Value	8-80 Bus Message Count	15-00 Operating Hours
	1-37 d-axis Inductance (Ld)	Other Ramps	6-16 Terminal 53 High Ref./Feedb. Value	8-81 Bus Error Count	15-01 Running Hours
	1-39 Motor Poles	Jog Ramp Time	6-19 Terminal 53 Filter Time Constant	8-82 Slave Messages Rcvd	15-02 kWh Counter
	1-4* Adv. Motor Data II	Quick Stop Ramp Time	6-20 Terminal 53 mode	8-83 Slave Error Count	15-03 Power-ups
	1-40 Back EMF at 1000 RPM	Limits / Warnings	6-2* Analog Input 54	8-84 Slave Messages Sent	15-04 Over Temps
			6-20 Terminal 54 Low Voltage	8-85 Slave Timeout Errors	15-05 Over Volts

15-06	Reset kWh Counter	16-73	Counter B	38-12	DAC scale	38-99	Signed Debug Info
15-07	Reset Running Hours Counter	16-79	Analog Output AO45	38-20	MOC_TestS16	40-0*	Debug only - Backup
15-3*	Alarm Log	16-8*	Fieldbus & FC Port	38-21	MOC_TestS16	40-0*	Debug parameters backup
15-30	Alarm Log: Error Code	16-86	FC Port REF 1	38-23	TestMoFunctions	40-00	TestMonitorMode_Backup
15-31	InternalFaultReason	16-9*	Diagnosis Readouts	38-24	DC Link Power Measurement		
15-4*	Drive Identification	16-90	Alarm Word	38-25	CheckSum		
15-40	FC Type	16-91	Alarm Word 2	38-30	Analog Input 53 (%)		
15-41	Power Section	16-92	Warning Word	38-31	Analog Input 54 (%)		
15-42	Voltage	16-93	Warning Word 2	38-32	Input Reference 1		
15-43	Software Version	16-94	Ext. Status Word	38-33	Input Reference 2		
15-44	Ordered TypeCode	16-95	Ext. Status Word 2	38-34	Input Reference Setting		
15-46	Drive Ordering No.	18-**	Info & Readouts	38-35	Feedback (%)		
15-47	Power Card Ordering No.	18-1*	Fire Mode Log	38-36	Fault Code		
15-48	LCP ID Num.	18-10	FireMode Log:Event	38-37	Control Word		
15-49	SW ID Control Card	20-**	Drive Closed-loop	38-38	ResetCountersControl		
15-50	SW ID Power Card	20-0*	Feedback	38-39	Active Set-up For BACnet		
15-51	Drive Serial Number	20-00	Feedback 1 Source	38-40	Name Of Analog Value 1 For BACnet		
15-53	Power Card Serial Number	20-00	Feedback 1 Conversion	38-41	Name Of Analog Value 3 For BACnet		
15-59*	Parameter Info	20-8*	PI Basic Settings	38-42	Name Of Analog Value 5 For BACnet		
15-92	Defined Parameters	20-81	PI Normal/ Inverse Control	38-43	Name Of Analog Value 6 For BACnet		
15-97	Application Type	20-83	PI Start Speed [Hz]	38-44	Name Of Binary Value 1 For BACnet		
15-98	Drive Identification	20-84	On Reference Bandwidth	38-45	Name Of Binary Value 2 For BACnet		
16-5*	Data Readouts	20-9*	PI Controller	38-46	Name Of Binary Value 3 For BACnet		
16-0*	General Status	20-91	PI Anti Windup	38-47	Name Of Binary Value 4 For BACnet		
16-00	Control Word	20-93	PI Proportional Gain	38-48	Name Of Binary Value 5 For BACnet		
16-01	Reference [Unit]	20-94	PI Integral Time	38-49	Name Of Binary Value 6 For BACnet		
16-02	Reference [%]	20-97	PI Feed Forward Factor	38-50	Name Of Binary Value 21 For BACnet		
16-03	Status Word	22-**	Appl. Functions	38-51	Name Of Binary Value 22 For BACnet		
16-05	Main Actual Value [%]	22-4*	Sleep Mode	38-52	Name Of Binary Value 33 For BACnet		
16-09	Custom Readout	22-40	Minimum Run Time	38-53	Bus Feedback 1 Conversion		
16-1*	Motor Status	22-41	Minimum Sleep Time	38-54	Run Stop Bus Control		
16-10	Power [kW]	22-43	Wake-up Speed [Hz]	38-58	Inverter ETR counter		
16-11	Power [hp]	22-44	Wake-up Ref/FB Diff	38-59	Rectifier ETR counter		
16-12	Motor Voltage	22-45	Setpoint Boost	38-60	DB_ErrorWarnings		
16-13	Frequency	22-46	Maximum Boost Time	38-61	Extended Alarm Word		
16-14	Motor current	22-47	Sleep Speed [Hz]	38-69	AMA_DebugS32		
16-15	Frequency [%]	22-6*	Broken Belt Detection	38-74	AOCDebug0		
16-18	Motor Thermal	22-60	Broken Belt Function	38-75	AOCDebug1		
16-3*	Drive Status	22-61	Broken Belt Torque	38-76	AO42_FixedMode		
16-30	DC Link Voltage	22-62	Broken Belt Delay	38-77	AO42_FixedValue		
16-34	Heatsink Temp.	24-**	Appl. Functions 2	38-78	DI_TestCounters		
16-35	Inverter Thermal	24-0*	Fire Mode	38-79	Protect Func. Counter		
16-36	Inv. Nom. Current	24-00	FM Function	38-80	Highest Lowest Couple		
16-37	Inv. Max. Current	24-05	FM Preset Reference	38-81	DB_SendDebugCmd		
16-38	SL Controller State	24-09	FM Alarm Handling	38-82	MaxTaskRunningTime		
16-5*	Ref. & Feedb.	24-1*	Drive Bypass	38-83	DebugInformation		
16-50	External Reference	24-10	Drive Bypass Function	38-85	DB_OptionSelector		
16-52	Feedback[Unit]	24-11	Drive Bypass Delay Time	38-86	EEPROM_Address		
16-6*	Inputs & Outputs	38-**	Debug only - see PNU 1429 (service code) also	38-87	EEPROM_Value		
16-60	Digital Input	38-00	All debug parameters	38-88	Logger Time Remain		
16-61	Terminal 53 Setting	38-00	TestMonitorMode	38-90	LCP FC Protocol select		
16-62	Analog Input AI53	38-01	Version And Stack	38-91	Motor Power Internal		
16-63	Terminal 54 Setting	38-02	Protocol SW version	38-92	Motor Voltage Internal		
16-64	Analog Input AI54	38-06	LCPEdit Set-up	38-93	Motor Frequency Internal		
16-65	Analog Output AO42 [mA]	38-07	EEPROMDataVern	38-94	Lsigma		
16-66	Digital Output	38-08	PowerDataVariantID	38-95	DB_SimulateAlarmWarningExStatus		
16-67	Pulse Input #29 [Hz]	38-09	AMA Retry	38-96	Data Logger Password		
16-71	Relay Output [bin]	38-10	DAC selection	38-97	Data Logging Period		
16-72	Counter A			38-98	Signal to Debug		

1.5 Acoustic Noise or Vibration

If the motor or the equipment driven by the motor, e.g., a fan blade, is making noise or vibrations at certain frequencies, try the following:

- Speed Bypass, parameter group 4-6* *Speed Bypass*
- Overmodulation, 14-03 *Overmodulation* set to [0] *Off*
- Switching pattern and switching frequency parameter group 14-0* *Inverter Switching*
- Resonance Dampening, 1-64 *Resonance Dampening*

1.6 Warnings and Alarms

Fault number	Alarm/Warning Bit Number	Fault text	Warning	Alarm	Trip locked	Cause of problem
2	16	Live zero error	X	X		Signal on terminal 53 or 54 is less than 50% of value set in 6-10 Terminal 53 Low Voltage, 6-12 Terminal 53 Low Current, 6-20 Terminal 54 Low Voltage or 6-22 Terminal 54 Low Current. See also parameter group 6-0* <i>Analog I/O Mode</i>
4	14	Mains ph. loss	X	X	X	Missing phase on supply side or too high voltage imbalance. Check supply voltage. See 14-12 <i>Function at Mains Imbalance</i>
7	11	DC over volt	X	X		Intermediate circuit voltage exceeds the limit.
8	10	DC under volt	X	X		Intermediate circuit voltage drops below the "voltage warning low" limit.
9	9	Inverter overload	X	X		More than 100% load for too long.
10	8	Motor ETR over	X	X		Motor is too hot due to more than 100% load for too long. See 1-90 <i>Motor Thermal Protection</i>
11	7	Motor th over	X	X		The thermistor or the thermistor connection is disconnected. See 1-90 <i>Motor Thermal Protection</i> .
13	5	Over Current	X	X	X	Inverter peak current limit is exceeded.
14	2	Earth Fault		X	X	Discharge from output phases to ground.
16	12	Short Circuit		X	X	Short-circuit in the motor or on the motor terminals.
17	4	Ctrl. word TO	X	X		No communication to the adjustable frequency drive. See parameter group 8-0* <i>General Settings</i> .
24	50	Fan Fault	X	X		The fan is not working (Only on 400 V 40–125 hp [30–90 kW] units).
30	19	U phase loss		X	X	Motor phase U is missing. Check the phase. See 4-58 <i>Missing Motor Phase Function</i> .
31	20	V phase loss		X	X	Motor phase V is missing. Check the phase. See 4-58 <i>Missing Motor Phase Function</i> .
32	21	W phase loss		X	X	Motor phase W is missing. Check the phase. See 4-58 <i>Missing Motor Phase Function</i> .
38	17	Internal fault		X	X	Contact the local Danfoss supplier.
44	28	Earth Fault		X	X	Discharge from output phases to ground, using the value of 15-31 <i>Alarm Log Value</i> if possible.
47	23	Control Voltage Fault	X	X	X	24 V DC may be overloaded.
48	25	VDD1 supply low		X	X	Control voltage low. Contact the local Danfoss supplier.
50		AMA calibration failed		X		Contact the local Danfoss supplier.

Fault number	Alarm/ Warning Bit Number	Fault text	Warning	Alarm	Trip locked	Cause of problem
51	15	AMA Unom,Inom		X		The setting of motor voltage, motor current and motor power is presumably wrong. Check the settings.
52		AMA low Inom		X		The motor current is too low. Check the settings.
53		AMA big motor		X		The motor is too big to perform AMA.
54		AMA small mot		X		The motor is too small to perform AMA.
55		AMA par. range		X		The parameter values found from the motor are outside acceptable range.
56		AMA user interrupt		X		The AMA has been interrupted by the user.
57		AMA timeout		X		Try to start the AMA again a number of times, until the AMA is carried out. NOTICE Repeated runs may heat the motor to a level where the resistance R_s and R_r are increased. In most cases, however, this is not critical.
58		AMA internal	X	X		Contact the local Danfoss supplier.
59	25	Current limit	X			The current is higher than the value in <i>4-18 Current Limit</i>
60	44	External Interlock		X		External interlock has been activated. To resume normal operation, apply 24 V DC to the terminal programmed for external interlock and reset the adjustable frequency drive (via serial communication, digital I/O, or by pressing reset button on keypad).
66	26	Heatsink Temperature Low	X			This warning is based on the temperature sensor in the IGBT module (Only on 400 V 40–125 hp [30–90 kW] units).
69	1	Pwr. Card Temp	X	X	X	The temperature sensor on the power card is either too hot or too cold.
79		Illegal power section configuration	X	X		Internal fault. Contact the local Danfoss supplier.
80	29	Drive initialized		X		All parameter settings are initialized to default settings.
87	47	Auto DC Braking	X			The drive is auto DC braking.
95	40	Broken Belt	X	X		Torque is below the torque level set for no load, indicating a broken belt. See parameter group 22-6* <i>Broken Belt Detection</i> .
126		Motor Rotating		X		High back emf voltage. Stop the rotor of the PM motor.
200		Fire Mode	X			Fire mode has been activated.
202		Fire Mode Limits Exceeded	X			Fire mode has suppressed one or more warranty voiding alarms.
250		New spare part		X	X	The power or switch mode power supply has been exchanged. (Only on 400 V 40–125 hp [30–90 kW] units). Contact the local Danfoss supplier.
251		New Typecode		X	X	The adjustable frequency drive has a new type code (only on 400 V 40–125 hp [30–90 kW] units). Contact the local Danfoss supplier.

Table 1.24 Warnings and Alarms

1.7 General Specifications

1.7.1 Line Power Supply 3x200–240 V AC

Adjustable frequency drive	PK25	PK37	PK75	P1K5	P2K2	P3K7	P5K5	P7K5	P11K	P15K	P18K	P22K	P30K	P37K	P45K
Typical shaft output [kW]	0.25	0.37	0.75	1.5	2.2	3.7	5.5	7.5	11.0	15.0	18.5	22.0	30.0	37.0	45.0
Typical shaft output [hp]	0.33	0.5	1.0	2.0	3.0	5.0	7.5	10.0	15.0	20.0	25.0	30.0	40.0	50.0	60.0
IP20 frame	H1	H1	H1	H1	H2	H3	H4	H4	H5	H6	H6	H7	H7	H8	H8
Max. cable size in terminals (line power, motor) [mm ² /AWG]	4/10	4/10	4/10	4/10	4/10	4/10	16/6	16/6	16/6	35/2	35/2	50/1	50/1	95/0	120/ (4/0)
Output current															
104 °F [40 °C] ambient temperature															
Continuous (3x200–240 V) [A]	1.5	2.2	4.2	6.8	9.6	15.2	22.0	28.0	42.0	59.4	74.8	88.0	115.0	143.0	170.0
Intermittent (3x200–240 V) [A]	1.7	2.4	4.6	7.5	10.6	16.7	24.2	30.8	46.2	65.3	82.3	96.8	126.5	157.3	187.0
Max. input current															
Continuous (3x200–240 V) [A]	1.1	1.6	2.8	5.6	8.6/ 7.2	14.1/ 12.0	21.0/ 18.0	28.3/ 24.0	41.0/ 38.2	52.7	65.0	76.0	103.7	127.9	153.0
Intermittent (3x200–240 V) [A]	1.2	1.8	3.1	6.2	9.5/ 7.9	15.5/ 13.2	23.1/ 19.8	31.1/ 26.4	45.1/ 42.0	58.0	71.5	83.7	114.1	140.7	168.3
Max. electrical fuses	<i>See chapter 1.3.5 Fuses and Circuit Breakers</i>														
Estimated power loss [W], Best case/typical ¹⁾	12/ 14	15/ 18	21/ 26	48/ 60	80/ 102	97/ 120	182/ 204	229/ 268	369/ 386	512	697	879	1149	1390	1500
Weight enclosure IP20 lb [kg]	4.41 [2.0]	4.41 [2.0]	4.41 [2.0]	4.63 [2.1]	7.5 [3.4]	9.92 [4.5]	17.42 [7.9]	17.42 [7.9]	20.94 [9.5]	54.01 [24.5]	54.01 [24.5]	79.37 [36.0]	79.37 [36.0]	112. 44 [51.0]	112. 44 [51.0]
Efficiency [%], best case/ typical ¹⁾	97.0/ 96.5	97.3/ 96.8	98.0/ 97.6	97.6/ 97.0	97.1/ 96.3	97.9/ 97.4	97.3/ 97.0	98.5/ 97.1	97.2/ 97.1	97.0	97.1	96.8	97.1	97.1	97.3
Output current															
122 °F [50 °C] ambient temperature															
Continuous (3x200–240 V) [A]	1.5	1.9	3.5	6.8	9.6	13.0	19.8	23.0	33.0	41.6	52.4	61.6	80.5	100.1	119
Intermittent (3x200–240 V) [A]	1.7	2.1	3.9	7.5	10.6	14.3	21.8	25.3	36.3	45.8	57.6	67.8	88.6	110.1	130.9

Table 1.25 3x200–240 V AC, PK25-P45K

¹⁾ At rated load conditions

1.7.2 Line Power Supply 3x380–480 V AC

Adjustable frequency drive	PK37	PK75	P1K5	P2K2	P3K0	P4K0	P5K5	P7K5	P11K	P15K
Typical shaft output [kW]	0.37	0.75	1.5	2.2	3.0	4.0	5.5	7.5	11.0	15.0
Typical shaft output [hp]	0.5	1.0	2.0	3.0	4.0	5.0	7.5	10.0	15.0	20.0
IP20 frame	H1	H1	H1	H2	H2	H2	H3	H3	H4	H4
Max. cable size in terminals (line power, motor) [mm ² /AWG]	4/10	4/10	4/10	4/10	4/10	4/10	4/10	4/10	16/6	16/6
Output current - +104 °F [+40 °C] ambient temperature										
Continuous (3x380–440 V) [A]	1.2	2.2	3.7	5.3	7.2	9.0	12.0	15.5	23.0	31.0
Intermittent (3x380–440 V) [A]	1.3	2.4	4.1	5.8	7.9	9.9	13.2	17.1	25.3	34.0
Continuous (3x440–480 V) [A]	1.1	2.1	3.4	4.8	6.3	8.2	11.0	14.0	21.0	27.0
Intermittent (3x440–480 V) [A]	1.2	2.3	3.7	5.3	6.9	9.0	12.1	15.4	23.1	29.7
Max. input current										
Continuous (3x380–440 V) [A]	1.2	2.1	3.5	4.7	6.3	8.3	11.2	15.1	22.1	29.9
Intermittent (3x380–440 V) [A]	1.3	2.3	3.9	5.2	6.9	9.1	12.3	16.6	24.3	32.9
Continuous (3x440–480 V) [A]	1.0	1.8	2.9	3.9	5.3	6.8	9.4	12.6	18.4	24.7
Intermittent (3x440–480 V) [A]	1.1	2.0	3.2	4.3	5.8	7.5	10.3	13.9	20.2	27.2
Max. electrical fuses	<i>See chapter 1.3.5 Fuses and Circuit Breakers</i>									
Estimated power loss [W], best case/typical ¹⁾	13/15	16/21	46/57	46/58	66/83	95/118	104/131	159/198	248/274	353/379
Weight enclosure IP20 lb [kg]	4.41 [2.0]	4.41 [2.0]	4.63 [2.1]	7.28 [3.3]	7.28 [3.3]	7.5 [3.4]	9.48 [4.3]	9.92 [4.5]	17.42 [7.9]	17.42 [7.9]
Efficiency [%], best case/typical 1	97.8/ 97.3	98.0/ 97.6	97.7/ 97.2	98.3/ 97.9	98.2/ 97.8	98.0/ 97.6	98.4/ 98.0	98.2/ 97.8	98.1/ 97.9	98.0/ 97.8
Output current - +122 °F [+50 °C] ambient temperature										
Continuous (3x380–440 V) [A]	1.04	1.93	3.7	4.85	6.3	8.4	10.9	14.0	20.9	28.0
Intermittent (3x380–440 V) [A]	1.1	2.1	4.07	5.4	6.9	9.2	12.0	15.4	23.0	30.8
Continuous (3x440–480 V) [A]	1.0	1.8	3.4	4.4	5.5	7.5	10.0	12.6	19.1	24.0
Intermittent (3x440–480 V) [A]	1.1	2.0	3.7	4.8	6.1	8.3	11.0	13.9	21.0	26.4

Table 1.26 3x380–480 V AC, PK37-P11K, H1-H4

Adjustable frequency drive	P18K	P22K	P30K	P37K	P45K	P55K	P75K	P90K
Typical shaft output [kW]	18.5	22.0	30.0	37.0	45.0	55.0	75.0	90.0
Typical shaft output [hp]	25.0	30.0	40.0	50.0	60.0	70.0	100.0	125.0
IP20 frame	H5	H5	H6	H6	H6	H7	H7	H8
Max. cable size in terminals (line power, motor) [mm ² /AWG]	16/6	16/6	35/2	35/2	35/2	50/1	95/0	120/250 MCM
Output current - +104 °F [+40 °C] ambient temperature								
Continuous (3x380–440 V)[A]	37.0	42.5	61.0	73.0	90.0	106.0	147.0	177.0
Intermittent (3x380–440 V) [A]	40.7	46.8	67.1	80.3	99.0	116.0	161.0	194.0
Continuous (3x440–480 V) [A]	34.0	40.0	52.0	65.0	80.0	105.0	130.0	160.0
Intermittent (3x440–480 V) [A]	37.4	44.0	57.2	71.5	88.0	115.0	143.0	176.0
Max. input current								
Continuous (3x380–440 V) [A]	35.2	41.5	57.0	70.0	84.0	103.0	140.0	166.0
Intermittent (3x380–440 V) [A]	38.7	45.7	62.7	77.0	92.4	113.0	154.0	182.0
Continuous (3x440–480 V) [A]	29.3	34.6	49.2	60.6	72.5	88.6	120.9	142.7
Intermittent (3x440–480 V) [A]	32.2	38.1	54.1	66.7	79.8	97.5	132.9	157.0
Max. electrical fuses								
Estimated power loss [W], best case/typical ¹⁾	412/456	475/523	733	922	1067	1133	1733	2141
Weight enclosure IP20 lb [kg]	20.94 [9.5]	20.94 [9.5]	54.01 [24.5]	54.01 [24.5]	54.01 [24.5]	79.37 [36.0]	79.37 [36.0]	112.44 [51.0]
Efficiency [%], best case/typical 1	98.1/97.9	98.1/97.9	97.8	97.7	98	98.2	97.8	97.9
Output current - +122 °F [+50 °C] ambient temperature								
Continuous (3x380–440 V) [A]	34.1	38.0	48.8	58.4	72.0	74.2	102.9	123.9
Intermittent (3x380–440 V) [A]	37.5	41.8	53.7	64.2	79.2	81.6	113.2	136.3
Continuous (3x440–480 V) [A]	31.3	35.0	41.6	52.0	64.0	73.5	91.0	112.0
Intermittent (3x440–480 V) [A]	34.4	38.5	45.8	57.2	70.4	80.9	100.1	123.2

Table 1.27 3x380–480 V AC, P18K-P90K, H5-H8

Adjustable frequency drive	PK75	P1K5	P2K2	P3K0	P4K0	P5K5	P7K5	P11K	P15K	P18K
Typical shaft output [kW]	0.75	1.5	2.2	3.0	4.0	5.5	7.5	11	15	18.5
Typical shaft output [hp]	1.0	2.0	3.0	4.0	5.0	7.5	10.0	15	20	25
IP54 frame	I2	I2	I2	I2	I2	I3	I3	I4	I4	I4
Max. cable size in terminals (line power, motor) [mm ² /AWG]	4/10	4/10	4/10	4/10	4/10	4/10	4/10	16/6	16/6	16/6
Output current										
104 °F [40 °C] ambient temperature										
Continuous (3x380–440 V) [A]	2.2	3.7	5.3	7.2	9.0	12.0	15.5	23.0	31.0	37.0
Intermittent (3x380–440 V) [A]	2.4	4.1	5.8	7.9	9.9	13.2	17.1	25.3	34.0	40.7
Continuous (3x440–480 V) [A]	2.1	3.4	4.8	6.3	8.2	11.0	14.0	21.0	27.0	34.0
Intermittent (3x440–480 V) [A]	2.3	3.7	5.3	6.9	9.0	12.1	15.4	23.1	29.7	37.4
Max. input current										
Continuous (3x380–440 V) [A]	2.1	3.5	4.7	6.3	8.3	11.2	15.1	22.1	29.9	35.2
Intermittent (3x380–440 V) [A]	2.3	3.9	5.2	6.9	9.1	12.3	16.6	24.3	32.9	38.7
Continuous (3x440–480 V) [A]	1.8	2.9	3.9	5.3	6.8	9.4	12.6	18.4	24.7	29.3
Intermittent (3 x 440–480 V) [A]	2.0	3.2	4.3	5.8	7.5	10.3	13.9	20.2	27.2	32.2
Max. electrical fuses	<i>See chapter 1.3.5 Fuses and Circuit Breakers</i>									
Estimated power loss [W], best case/typical ¹⁾	21/ 16	46/ 57	46/ 58	66/ 83	95/ 118	104/ 131	159/ 198	248/ 274	353/ 379	412/ 456
Weight enclosure IP54 [kg]	11.69 [5.3]	11.69 [5.3]	11.69 [5.3]	11.69 [5.3]	11.69 [5.3]	15.87 [7.2]	15.87 [7.2]	30.42 [13.8]	30.42 [13.8]	30.42 [13.8]
Efficiency [%], best case/typical 1	98.0/ 97.6	97.7/ 97.2	98.3/ 97.9	98.2/ 97.8	98.0/ 97.6	98.4/ 98.0	98.2/ 97.8	98.1/ 97.9	98.0/ 97.8	98.1/ 97.9
Output current - +122 °F [+50 °C] ambient temperature										
Continuous (3x380–440 V) [A]	1.93	3.7	4.85	6.3	7.5	10.9	14.0	20.9	28.0	33.0
Intermittent (3x380–440 V) [A]	2.1	4.07	5.4	6.9	9.2	12.0	15.4	23.0	30.8	36.3
Continuous (3x440–480 V) [A]	1.8	3.4	4.4	5.5	6.8	10.0	12.6	19.1	24.0	30.0
Intermittent (3x440–480 V) [A]	2.0	3.7	4.8	6.1	8.3	11.0	13.9	21.0	26.4	33.0

Table 1.28 3x380-480 V AC, PK75-P18K, I2-I4

Adjustable frequency drive	P22K	P30K	P37K	P45K	P55K	P75K	P90K
Typical shaft output [kW]	22.0	30.0	37.0	45.0	55.0	75.0	90.0
Typical shaft output [hp]	30.0	40.0	50.0	60.0	70.0	100.0	125.0
IP54 frame	I6	I6	I6	I7	I7	I8	I8
Max. cable size in terminals (line power, motor) [mm ² /AWG]	35/2	35/2	35/2	50/1	50/1	95/(3/0)	120/(4/0)
Output current							
104 °F [40 °C] ambient temperature							
Continuous (3x380–440 V) [A]	44.0	61.0	73.0	90.0	106.0	147.0	177.0
Intermittent (3x380–440 V) [A]	48.4	67.1	80.3	99.0	116.6	161.7	194.7
Continuous (3x440–480 V) [A]	40.0	52.0	65.0	80.0	105.0	130.0	160.0
Intermittent (3x440–480 V) [A]	44.0	57.2	71.5	88.0	115.5	143.0	176.0
Max. input current							
Continuous (3x380–440 V) [A]	41.8	57.0	70.3	84.2	102.9	140.3	165.6
Intermittent (3x380–440 V) [A]	46.0	62.7	77.4	92.6	113.1	154.3	182.2
Continuous (3x440–480 V) [A]	36.0	49.2	60.6	72.5	88.6	120.9	142.7
Intermittent (3 x 440–480 V) [A]	39.6	54.1	66.7	79.8	97.5	132.9	157.0
Max. electrical fuses							
Estimated power loss [W], best case/typical ¹⁾	496	734	995	840	1099	1520	1781
Weight enclosure IP54 [kg]	59.53 [27]	59.53 [27]	59.53 [27]	99.21 [45]	99.21 [45]	143.3 [65]	143.3 [65]
Efficiency [%], best case/Typical 1	98.0	97.8	97.6	98.3	98.2	98.1	98.3
Output current - +122 °F [+50 °C] ambient temperature							
Continuous (3x380–440 V) [A]	35.2	48.8	58.4	63.0	74.2	102.9	123.9
Intermittent (3x380–440 V) [A]	38.7	53.9	64.2	69.3	81.6	113.2	136.3
Continuous (3x440–480 V) [A]	32.0	41.6	52.0	56.0	73.5	91.0	112.0
Intermittent (3x440–480 V) [A]	35.2	45.8	57.2	61.6	80.9	100.1	123.2

Table 1.29 3x380–480 V AC, P11K-P90K, I6-I8

1.7.3 Line Power Supply 3x525–600 V AC

Adjustable frequency drive	P2K2	P3K0	P3K7	P5K5	P7K5	P11K	P15K	P18K	P22K	P30K	P37K	P45K	P55K	P75K	P90K
Typical shaft output [kW]	2.2	3.0	3.7	5.5	7.5	11.0	15.0	18.5	22.0	30.0	37	45.0	55.0	75.0	90.0
Typical shaft output [hp]	3.0	4.0	5.0	7.5	10.0	15.0	20.0	25.0	30.0	40.0	50.0	60.0	70.0	100.0	125.0
IP20 frame	H9	H9	H9	H9	H9	H10	H10	H6	H6	H6	H7	H7	H7	H8	H8
Max. cable size in terminals (line power, motor) [mm ² /AWG]	4/10	4/10	4/10	4/10	4/10	10/8	10/8	35/2	35/2	35/2	50/1	50/1	50/1	95/0	120/ (4/0)
Output current - +104 °F [+40 °C] ambient temperature															
Continuous (3x525–550 V) [A]	4.1	5.2	6.4	9.5	11.5	19.0	23.0	28.0	36.0	43.0	54.0	65.0	87.0	105.0	137.0
Intermittent (3x525–550 V) [A]	4.5	5.7	7.0	10.5	12.7	20.9	25.3	30.8	39.6	47.3	59.4	71.5	95.7	115.5	150.7
Continuous (3x551–600 V) [A]	3.9	4.9	6.1	9.0	11.0	18.0	22.0	27.0	34.0	41.0	52.0	62.0	83.0	100.0	131.0
Intermittent (3x551–600 V) [A]	4.3	5.4	6.7	9.9	12.1	19.8	24.2	29.7	37.4	45.1	57.2	68.2	91.3	110.0	144.1
Max. input current															
Continuous (3x525–550 V) [A]	3.7	5.1	5.0	8.7	11.9	16.5	22.5	27.0	33.1	45.1	54.7	66.5	81.3	109.0	130.9
Intermittent (3x525–550 V) [A]	4.1	5.6	6.5	9.6	13.1	18.2	24.8	29.7	36.4	49.6	60.1	73.1	89.4	119.9	143.9
Continuous (3x551–600 V) [A]	3.5	4.8	5.6	8.3	11.4	15.7	21.4	25.7	31.5	42.9	52.0	63.3	77.4	103.8	124.5
Intermittent (3x551–600 V) [A]	3.9	5.3	6.2	9.2	12.5	17.3	23.6	28.3	34.6	47.2	57.2	69.6	85.1	114.2	137.0
Max. electrical fuses	See chapter 1.3.5 Fuses and Circuit Breakers														
Estimated power loss [W], best case/typical ¹⁾	65	90	110	132	180	216	294	385	458	542	597	727	1092	1380	1658
Weight enclosure IP54 [kg]	14.55 [6.6]	14.55 [6.6]	14.55 [6.6]	14.55 [6.6]	14.55 [6.6]	25.35 [11.5]	25.35 [11.5]	54.01 [24.5]	54.01 [24.5]	54.01 [24.5]	79.37 [36.0]	79.37 [36.0]	79.37 [36.0]	112. 44 [51.0]	112. 44 [51.0]
Efficiency [%], best case/typical 1	97.9	97	97.9	98.1	98.1	98.4	98.4	98.4	98.4	98.5	98.5	98.7	98.5	98.5	98.5
Output current - +122 °F [+50 °C] ambient temperature															
Continuous (3x525–550 V) [A]	2.9	3.6	4.5	6.7	8.1	13.3	16.1	19.6	25.2	30.1	37.8	45.5	60.9	73.5	95.9
Intermittent (3x525–550 V) [A]	3.2	4.0	4.9	7.4	8.9	14.6	17.7	21.6	27.7	33.1	41.6	50.0	67.0	80.9	105.5
Continuous (3x551–600 V) [A]	2.7	3.4	4.3	6.3	7.7	12.6	15.4	18.9	23.8	28.7	36.4	43.3	58.1	70.0	91.7
Intermittent (3x551–600 V) [A]	3.0	3.7	4.7	6.9	8.5	13.9	16.9	20.8	26.2	31.6	40.0	47.7	63.9	77.0	100.9

Table 1.30 3x525–600 V AC, P2K2-P90K, H6-H10

1.7.4 EMC Test Results

The following test results have been obtained using a system with an adjustable frequency drive, a shielded control cable, a control box with potentiometer, as well as a motor shielded cable.

RFI Filter Type	Conduct emission. Maximum shielded cable length [m]						Radiated emission			
	Industrial environment				Housing, trades and light industries		Industrial environment		Housing, trades and light industries	
	EN 55011 Class A2		EN 55011 Class A1		EN 55011 Class B		EN 55011 Class A1		EN 55011 Class B	
	Without external filter	With external filter	Without external filter	With external filter	Without external filter	With external filter	Without external filter	With external filter	Without external filter	With external filter
H4 RFI filter (Class A1)										
0.34–15 hp [0.25–11 kW] 3x200–240 V IP20			25	50		20	Yes	Yes		No
0.5–30 hp [0.37–22 kW] 3x380–480 V IP20			25	50		20	Yes	Yes		No
H2 RFI filter (Class A2)										
20–60 hp [15–45 kW] 3x200–240 V IP20	25						No		No	
40–125 hp [30–90 kW] 3x380–480 V IP20	25						No		No	
1–25 [0.75–18.5 kW] 3x380–480 V IP54	25						Yes			
30–125 hp [22–90 kW] 3x380–480 V IP54	25						No		No	
H3 RFI filter (Class A1/B)										
20–60 hp [15–45 kW] 3x200–240 V IP20			50		20		Yes		No	
40–125 hp [30–90 kW] 3x380–480 V IP20			50		20		Yes		No	
1–25 [0.75–18.5 kW] 3x380–480 V IP54			25		10		Yes			

RFI Filter Type	Conduct emission. Maximum shielded cable length [m]						Radiated emission			
	Industrial environment				Housing, trades and light industries		Industrial environment		Housing, trades and light industries	
	EN 55011 Class A2		EN 55011 Class A1		EN 55011 Class B		EN 55011 Class A1		EN 55011 Class B	
	Without external filter	With external filter	Without external filter	With external filter	Without external filter	With external filter	Without external filter	With external filter	Without external filter	With external filter
30–125 hp [22–90 kW] 3x380–480 V IP54			25		10		Yes		No	

Table 1.31 Test Results

1.7.5 General Specifications

Protection and features

- Electronic thermal motor protection against overload.
- Temperature monitoring of the heatsink ensures that the adjustable frequency drive trips in case of overtemperature.
- The adjustable frequency drive is protected against short-circuits between motor terminals U, V, W.
- When a motor phase is missing, the adjustable frequency drive trips and issues an alarm.
- When a line phase is missing, the adjustable frequency drive trips or issues a warning (depending on the load).
- Monitoring of the intermediate circuit voltage ensures that the adjustable frequency drive trips when the intermediate circuit voltage is too low or too high.
- The adjustable frequency drive is protected against ground faults on motor terminals U, V, W.

Line power supply (L1, L2, L3)

Supply voltage	200–240 V $\pm 10\%$
Supply voltage	380–480 V $\pm 10\%$
Supply voltage	525–600 V $\pm 10\%$
Supply frequency	50/60 Hz
Max. temporary imbalance between line phases	3.0% of rated supply voltage
True Power Factor (λ)	≥ 0.9 nominal at rated load
Displacement Power Factor ($\cos\phi$) near unity	(>0.98)
Switching on the input supply L1, L2, L3 (power-ups) enclosure frame H1-H5, I2, I3, I4	Max. 2 times/min.
Switching on the input supply L1, L2, L3 (power-ups) enclosure frame H6-H8, I6-I8	Max. 1 time/min.
Environment according to EN 60664-1	overvoltage category III/pollution degree 2
The unit is suitable for use on a circuit capable of delivering not more than 100,000 RMS symmetrical Amperes, 240/480 V maximum.	

Motor output (U, V, W)

Output voltage	0–100% of supply voltage
Output frequency	0–200 Hz (VVC ^{plus}), 0–400 Hz (u/f)
Switching on output	Unlimited
Ramp times	0.05–3600 s

Cable lengths and cross-sections

Max. motor cable length, shielded/armored (EMC-compatible installation)	See chapter 1.7.4 EMC Test Results
Max. motor cable length, non-shielded/unarmored	50 m
Max. cross-section to motor, line power*	
Cross-section DC terminals for filter feedback on enclosure frame H1-H3, I2, I3, I4	4 mm ² /11 AWG
Cross-section DC terminals for filter feedback on enclosure frame H4-H5	16 mm ² /6 AWG
Maximum cross-section to control terminals, rigid wire	2.5 mm ² /14 AWG)
Maximum cross-section to control terminals, flexible cable	2.5 mm ² /14 AWG)
Minimum cross-section to control terminals	0.05 mm ² /30 AWG

*See chapter 1.7.2 Line Power Supply 3x380–480 V AC for more information

Digital inputs

Programmable digital inputs	4
Terminal number	18, 19, 27, 29
Logic	PNP or NPN
Voltage level	0–24 V DC
Voltage level, logic '0' PNP	<5 V DC
Voltage level, logic '1' PNP	>10 V DC
Voltage level, logic '0' NPN	>19 V DC
Voltage level, logic '1' NPN	<14 V DC
Maximum voltage on input	28 V DC
Input resistance, R _i	Approx. 4 kΩ
Digital input 29 as thermistor input	Fault: >2.9 kΩ and no fault: <800 Ω
Digital input 29 as Pulse input	Max. frequency 32 kHz Push-Pull-Driven & 5 kHz (O.C.)

Analog inputs

Number of analog inputs	2
Terminal number	53, 54
Terminal 53 mode	Parameter 6-19: 1=voltage, 0=current
Terminal 54 mode	Parameter 6-29: 1=voltage, 0=current
Voltage level	0–10 V
Input resistance, R _i	Approx. 10 kΩ
Max. voltage	20 V
Current level	0/4 to 20 mA (scalable)
Input resistance, R _i	<500 Ω
Max. current	29 mA

Analog output

Number of programmable analog outputs	2
Terminal number	42, 45 ¹⁾
Current range at analog output	0/4–20 mA
Max. load to common at analog output	500 Ω
Max. voltage at analog output	17 V
Accuracy on analog output	Max. error: 0.4% of full scale
Resolution on analog output	10 bit

¹⁾ Terminal 42 and 45 can also be programmed as digital outputs.

Quick Guide
Quick Guide
Digital output^{A)}

Number of digital outputs	2
Terminal number	42, 45 ¹⁾
Voltage level at digital output	17 V
Max. output current at digital output	20 mA
Max. load at digital output	1 kΩ

1) Terminals 42 and 45 can also be programmed as analog output.

Control card, RS-485 serial communication^{A)}

Terminal number	68 (P, TX+, RX+), 69 (N, TX-, RX-)
Terminal number	61 Common for terminals 68 and 69

Control card, 24 V DC output

Terminal number	12
Max. load	80 mA

Relay output

Programmable relay output	2
Relay 01 and 02	01-03 (NC), 01-02 (NO), 04-06 (NC), 04-05 (NO)
Max. terminal load (AC-1) ¹⁾ on 01-02/04-05 (NO) (Resistive load)	250 V AC, 3 A
Max. terminal load (AC-15) ¹⁾ on 01-02/04-05 (NO) (Inductive load @ cosφ 0.4)	250 V AC, 0.2 A
Max. terminal load (DC-1) ¹⁾ on 01-02/04-05 (NO) (Resistive load)	30 V DC, 2 A
Max. terminal load (DC-13) ¹⁾ on 01-02/04-05 (NO) (Inductive load)	24 V DC, 0.1 A
Max. terminal load (AC-1) ¹⁾ on 01-03/04-06 (NC) (Resistive load)	250 V AC, 3 A
Max. terminal load (AC-15) ¹⁾ on 01-03/04-06 (NC) (Inductive load @ cosφ 0.4)	250 V AC, 0.2 A
Max. terminal load (DC-1) ¹⁾ on 01-03/04-06 (NC) (Resistive load)	30 V DC, 2 A
Min. terminal load on 01-03 (NC), 01-02 (NO) 24 V DC 10 mA, 24 V AC 20 mA	
Environment according to EN 60664-1	Overvoltage category III/pollution degree 2

¹⁾ IEC 60947 parts 4 and 5.

Control card, 10 V DC output^{A)}

Terminal number	50
Output voltage	10.5 V ±0.5 V
Max. load	25 mA

^{A)} All inputs, outputs, circuits, DC supplies and relay contacts are galvanically isolated from the supply voltage (PELV) and other high-voltage terminals.

Surroundings

Enclosure	IP20
Enclosure kit available.	IP21, TYPE 1
Vibration test	1.0 g
Max. relative humidity	5%–95% (IEC 60721-3-3; Class 3K3 (non-condensing) during operation
Aggressive environment (IEC 60721-3-3), coated (standard) frame H1-H5	Class 3C3
Aggressive environment (IEC 60721-3-3), non-coated frame H6-H10	Class 3C2
Aggressive environment (IEC 60721-3-3), coated (optional) frame H6-H10	Class 3C3
Test method according to IEC 60068-2-43 H2S (10 days)	
Ambient temperature	See max. output current at 104/122 °F [40/50 °C] in <i>chapter 1.7.2 Line Power Supply 3x380–480 V AC</i>

Derating for high ambient temperature, see .

Minimum ambient temperature during full-scale operation	32 °F [0 °C]
Minimum ambient temperature at reduced performance, enclosure frame H1-H5	-4 °F [-20 °C]
Minimum ambient temperature at reduced performance, enclosure frame H6-H10	14 °F [-10 °C]
Temperature during storage/transport	-22 to +149/158 °F [-30 to +65/70 °C]
Maximum altitude above sea level without derating	3,300 ft [1,000 m]
Maximum altitude above sea level with derating	10,000 ft [3,000 m]
Derating for high altitude, see	
Safety standards	EN/IEC 61800-5-1, UL 508C
EMC standards, Emission	EN 61800-3, EN 61000-6-3/4, EN 55011, IEC 61800-3
EMC standards, Immunity	EN 61800-3, EN 61000-3-12, EN 61000-6-1/2, EN 61000-4-2, EN 61000-4-3, EN 61000-4-4, EN 61000-4-5, EN 61000-4-6

1.8 Special Conditions

1.8.1 Derating for Ambient Temperature and Switching Frequency

The ambient temperature measured over 24 hours should be at least 9 °F [5 °C] lower than the max. ambient temperature. If the adjustable frequency drive is operated at a high ambient temperature, the continuous output current should be decreased. For derating curve, see *VLT[®] HVAC Basic Design Guide*.

1.8.2 Derating for Low Air Pressure

The cooling capability of air is decreased at low air pressure. For altitudes above 6,600 feet [2 km], contact Danfoss regarding PELV. Below 3,300 ft [1,000 m] altitude, no de-rating is necessary, but above 3,281 ft [1,000 m], the ambient temperature or the maximum output current should be decreased. Decrease the output by 1% per 330 ft [100 m] altitude above 3,300 ft [1,000 m] or reduce the max. ambient temperature by 1° per 660 ft [200 m].

1.9 Options for VLT[®] HVAC Basic Drive FC 101

For options, see the *VLT[®] HVAC Basic Drive FC 101 Design Guide*.

1.10 MCT 10 Support

MCT 10 Set-up Software information is available at: www.danfoss.com/BusinessAreas/DrivesSolutions/fc101driveupdates



www.danfoss.com/drives

.....
Danfoss shall not be responsible for any errors in catalogs, brochures or other printed material. Danfoss reserves the right to alter its products at any time without notice, provided that alterations to products already on order shall not require material changes in specifications previously agreed upon by Danfoss and the Purchaser. All trademarks in this material are property of the respective companies. Danfoss and the Danfoss logotype are trademarks of Danfoss A/S. All rights reserved.
.....

